

Mr. Jason Pelton
Project Manager
New York State Department of Environmental Conservation
Remedial Bureau D
625 Broadway
Albany, New York 12233-7015

Arcadis of New York, Inc.
Two Huntington Quadrangle
Suite 1S10
Melville
New York 11747
Tel 631 249 7600
Fax 631 249 7610
www.arcadis.com

Subject:

2017 Annual Operation Maintenance and Monitoring Report,
Operable Unit 2, Northrop Grumman Systems Corporation and Naval Weapons
Industrial Reserve Plant (NWIRP) Sites, Bethpage, New York.
(NYSDEC Site #s 1-30-003A and B)

ENVIRONMENT

Date:
March 29, 2018

Dear Jason:

On behalf of Northrop Grumman Systems Corporation (Northrop Grumman), Arcadis is providing the NYSDEC with the 2017 Annual Operation Maintenance and Monitoring Report (Report). This Report was prepared to document the operation, maintenance, and monitoring (OM&M) activities conducted for the on-site portion of the Operable Unit 2 (OU2) groundwater remedy and the results of ongoing volatile organic compound (VOC) and inorganic monitoring in groundwater to meet the remedial objectives set forth in the March 2001 OU2 Record of Decision (ROD).

Contact:
David E. Stern

Phone:
631.391.5284

Email:
david.stern@arcadis.com

Our ref:
NY001496.22TM.RPTI4
NY001496.23TM.NAVI4

Mr. Jason Pelton
March 29, 2018

Please contact us if you have any questions or comments.

Sincerely,

Arcadis of New York, Inc.



David E. Stern
Senior Hydrogeologist

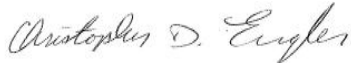

Christopher Engler, P.E. 069748
Engineer of Record

Copies:

Ed Hannon – Northrop Grumman
Walter Parish – NYSDEC Region 1
Donald Hesler – NYSDEC
Steven Scharf – NYSDEC
Steven Karpinski – New York State Department of Health
Joseph DeFranco – Nassau County Department of Health
Lora Fly – NAVFAC Midlant Environmental
David Brayack – TetraTech NUS, Inc.
Roger Smith – Glenn Springs Holdings, Inc.
Manfred Bohms – Steel Equities
Mike Negrelli – USEPA
Lorenzo Thantu – USEPA
Matthew Russo – Town of Oyster Bay
Stan Carey – Massapequa Water District
Richard Kern – New York American Water
Frank Koch – South Farmingdale Water District
John Reinhardt – Town of Hempstead Water District
Michael Boufis – Bethpage Water District
File

Northrop Grumman Systems Corporation

2017 ANNUAL OPERATION, MAINTENANCE AND MONITORING REPORT

Operable Unit 2- Groundwater
Bethpage, New York
NYSDEC Sites # 1-30-003A and 1-30-003B

March 29, 2018



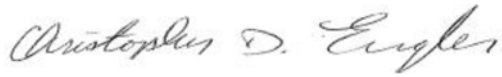

Christopher Engler, PE
Engineer of Record | New York PE-069748



Carlo San Giovanni
Project Manager



Michael F. Wolfert
Project Director

2017 ANNUAL OPERATION, MAINTENANCE AND MONITORING REPORT

Operable Unit 2

Northrop Grumman Systems Corporation
Bethpage, New York
NYSDEC Site # 1-30-003A

Naval Weapons Industrial Reserve Plant
Bethpage, New York
NYSDEC Site # 1-30-003B

Prepared for:

Northrop Grumman Systems Corporation

Prepared by:

Arcadis of New York, Inc.
Two Huntington Quadrangle
Suite 1S10
Melville
New York 11747
Tel 631 249 7600
Fax 631 249 7610

Our Ref.:

NY001496.22TM.RPT14

Date:

March 29, 2018

This document is intended only for the use of the individual or entity for which it was prepared and may contain information that is privileged, confidential and exempt from disclosure under applicable law. Any dissemination, distribution or copying of this document is strictly prohibited.

CONTENTS

1	Introduction	1
2	Site Overview	2
2.1	Description of Site	2
2.2	Nature and Extent of Impacted Groundwater	2
2.3	Remedial Action Objectives	2
2.4	Main Features/Components of the Remedy	3
3	Operation and Maintenance	4
3.1	Summary of O&M Completed	4
3.2	Performance Evaluation	5
4	Monitoring	6
4.1	Summary of Monitoring Completed	6
4.2	Summary of Monitoring Results	8
4.2.1	Remedial System Performance Monitoring	8
4.2.2	Remedial System Compliance Monitoring	9
4.2.2.1	Water Discharge	9
4.2.2.2	Air Discharge	9
4.2.3	Hydraulic Monitoring and Groundwater Flow	10
4.2.4	ONCT Hydraulic Effectiveness Program	12
4.2.5	Groundwater Quality	13
4.2.5.1	Volatile Organic Compounds	13
4.2.5.1.1	Shallow/Intermediate Zones	14
4.2.5.1.2	Deep and Deep2 Zones	14
4.2.5.1.3	Deep3 Zone	16
4.2.5.2	Outpost Well Monitoring	16
4.2.5.3	Cadmium and Chromium	17
4.2.5.4	Tentatively Identified Compounds	18
4.2.5.5	1,4-Dioxane	18
4.2.5.6	Vinyl Chloride Monomer	18
4.2.5.7	QA/QC Samples and Data Validation	19

2017 Annual Operation, Maintenance
and Monitoring Report
Operable Unit 2

5	Conclusions	19
6	Suggestions for Continued Monitoring	19
7	Certification Statement	21
8	References	22

TABLES

Table 1A	Summary of Weekly Monitoring Data 2017, Tower 96 Treatment System
Table 1B	Summary of Weekly Monitoring Data 2017, Tower 102 Treatment System
Table 2	Summary of Non-Routine Maintenance, 2017, ONCT Treatment System
Table 3	Operational Summary for the On-Site Portion of the OU2 Groundwater Remedy, 2017
Table 4	Concentrations of Constituents Detected in Remedial Wells and Treatment System Influent/Effluent 2017
Table 5A	Summary of Influent, Mid-Effluent, and Sup-Midtrain Air Concentrations, and Effluent Air Emissions 2017, Tower 96 Treatment System
Table 5B	Summary of Influent, Air Concentrations, and Effluent Air Emissions 2017, Tower 102 Treatment System
Table 5C	Summary of Trichloroethene Mass Removal 2017, Tower 96 Treatment System
Table 5D	Summary of Trichloroethene Mass Removal 2017, Tower 102 Treatment System
Table 6A	Summary of Effluent Air Emissions Model Output 2017, Tower 96 Treatment System
Table 6B	Summary of Effluent Air Emissions Model Output 2017, Tower 102 Treatment System
Table 7	Summary of SPDES Effluent Water Sample Analytical Results 2017, ONCT Treatment System
Table 8	Water-Level Measurement Data and Remedial Well Specific Capacities, Second Quarter, 2017
Table 9	Water-Level Measurement Data and Remedial Well Specific Capacities, Fourth Quarter, 2017
Table 10	Concentrations of Volatile Organic Compounds in Groundwater Samples Collected from Wells in the Shallow Zone
Table 11	Concentrations of Volatile Organic Compounds in Groundwater Samples Collected from Wells in the Intermediate Zone
Table 12	Concentrations of Volatile Organic Compounds in Groundwater Samples Collected from Wells in the Deep Zone

2017 Annual Operation, Maintenance
and Monitoring Report
Operable Unit 2

Table 13	Concentrations of Volatile Organic Compounds in Groundwater Samples Collected from Wells in the Deep 2 Zone
Table 14	Concentrations of Volatile Organic Compounds in Groundwater Samples Collected from Wells in the Deep 3 Zone
Table 15	Concentrations of Site-Related Volatile Organic Compounds in Outpost Wells, 2017
Table 16	Concentrations of Metals in Groundwater Monitoring Wells
Table 17	Concentrations of 1,4-Dioxane in Groundwater Monitoring Wells and Remedial Wells
Table 18	Comparison of Fourth Quarter 2017 Vertical Hydraulic Gradients to Model-Predicted Gradients
Table 19A	Concentrations of Volatile Organic Compounds and 1,4-Dioxane in Blank Samples
Table 19B	Concentrations of Metals in Blank Samples

FIGURES

Figure 1	Locations of Wells and On-Site Groundwater Remedy
Figure 2	ONCT Groundwater Extraction and Treatment System Site Plan
Figure 3	ONCT Groundwater Extraction and Treatment System Schematic
Figure 4	Remedial Wells Total VOC Mass Recovery Rates through December 2017
Figure 5	Remedial wells Yearly Total VOC Mass Removed Through December 2017
Figure 6	Remedial Wells Cumulative Total VOC Mass Removed through December 2017
Figure 7	Total Volatile Organic Compound Concentrations (Southern and Southwestern Site Boundary) in On-Site Deep 2 Monitoring Wells and OU2 Remedial Wells
Figure 8	Total Volatile Organic Compound Concentrations (Southern and Southeastern Site Boundary) in On-Site/Near Site Deep and Deep 2 Monitoring Wells and OU2 Remedial Wells
Figure 9	Water Table Elevation and Generalized Horizontal Groundwater Flow Directions in the Shallow/Intermediate Zone, October 2017
Figure 10	Potentiometric Surface Elevation and Generalized Horizontal Groundwater Flow Directions in the Deep 2 Zone, October 2017
Figure 11	Site Plan/Locations of Cross-Sections
Figure 12	Cross-Section A-A' TVOCs in Groundwater 2017
Figure 13	Cross-Section B-B' TVOCs in Groundwater 2017
Figure 14	Deep Zone Total Volatile Organic Compound Concentrations in Vertical Profile Borings and Wells, 2017

2017 Annual Operation, Maintenance
and Monitoring Report
Operable Unit 2

- Figure 15 Deep 2 Zone Total Volatile Organic Compound Concentrations in Vertical Profile Borings and Wells, 2017
- Figure 16 Deep 3 Total Volatile Organic Compound Concentrations in Vertical Profile Borings and Wells, 2017
- Figure 17 Model Simulated Groundwater Elevations and Groundwater Capture Zone, Fourth Quarter 2017 – Layers 5 through 8
- Figure 18 Total Volatile Organic Compound Concentrations in On-Site Intermediate and Deep Monitoring Wells
- Figure 19 Total Volatile Organic Compound Concentrations in Off-Site Deep Monitoring Wells (Southeast of the Site)
- Figure 20 Total Volatile Organic Compound Concentrations in Off-Site Deep2 Monitoring Wells (Southeast of the Site)
- Figure 21 Total Volatile Organic Compound Concentrations in Off-Site Deep-Deep2 Monitoring Wells (South of the Site)
- Figure 21A Total Volatile Organic Compound Concentrations in RE108D1 and RE108D2 Wells (South of the Site)
- Figure 22 Total Volatile Organic Compound Concentrations in GM-38 Area Deep and Deep2 Monitoring Wells
- Figure 23 TVOCs Concentrations in Outpost Wells BPOW1-1, BPOW1-2, BPOW1-3, BPOW1-4, BPOW1-5 and BPOW1-6 (Wells monitor SFWD Well Field 1)
- Figure 24 TVOCs Concentrations in Outpost Wells BPOW2-1, BPOW2-2 and BPOW2-3 (Wells Monitor SFWD Well Field 3)
- Figure 25 TVOCs Concentrations in Outpost Wells BPOW3-1, BPOW3-2, BPOW3-3 and BPOW3-4 (Wells Monitor NYAW Seaman's Neck Well Field)
- Figure 26 TVOCs Concentrations in Outpost Wells BPOW4-1R and BPOW4-2R (Wells Monitor Town of Hempstead Levittown Water District Well N-5303)
- Figure 27 Total Cadmium Concentrations in Shallow Monitoring Wells Near Former Plant 2
- Figure 28 Total Chromium Concentrations in Shallow Monitoring Wells Near Former Plant 2
- Figure 29 Total Chromium Concentrations in Shallow Monitoring Wells Near Former Plant 1

2017 Annual Operation, Maintenance
and Monitoring Report
Operable Unit 2

APPENDICES

Appendix A	Daily Site Visits
Appendix B	Hazardous Waste Manifests
Appendix C	Supplemental Monitoring Well GM-21D2 Data Assessment
Appendix D	SPDES Discharge Monitoring Reports
Appendix E	2017 Groundwater Sampling Logs and Chain of Custody Records
Appendix F	Supplemental Groundwater Quality Data
Appendix G	Supplemental Modeling Assessment of ONCT Hydraulic Effectiveness

1 INTRODUCTION

Arcadis of New York, Inc. (Arcadis) on behalf of Northrop Grumman Systems Corporation (Northrop Grumman), has prepared this OU2 2017 Annual Operation, Maintenance and Monitoring Report to document the operation, maintenance, and monitoring (OM&M) activities conducted for the on-site portion of the Operable Unit 2 (OU2) groundwater remedy for the Northrop Grumman Systems Corporation (Northrop Grumman), Bethpage, New York facility (Site No. 1-30-003A) and the former Naval Weapons Industrial Reserve Plant (NWIRP), Bethpage New York (Site No. 1-30-003B) (herein referred to as the "Site"). This report also documents the results of:

- Groundwater monitoring of metals near former Northrop Grumman Plants 1 and 2;
- Groundwater monitoring of volatile organic compounds (VOCs) in downgradient (off-site) areas; and
- Groundwater monitoring of VOCs in outpost wells in the distal portion of the off-site plume.

The above activities were conducted by Northrop Grumman to meet the remedial action objectives (RAOs) set forth in the March 2001 OU2 Record of Decision (ROD) (NYSDEC 2001), and in accordance with the (OM&M) Manual (Arcadis 2014a) and associated Groundwater Monitoring Plan (Arcadis 2014b,) Groundwater Monitoring Plan Addendum in August 2015 (NYSDEC, 2015b), and the recent (June 2016) Updated Groundwater Monitoring Plan (Arcadis 2016a). The above-referenced OM&M manual and monitoring plans were submitted to the New York State Department of Environmental Conservation (NYSDEC) pursuant to the OU2 Administrative Order on Consent (NYSDEC 2015a) Index # W1-118-14-12, executed April 21, 2015 (NYSDEC 2015a). The NYSDEC conditionally approved the Groundwater Monitoring Plan Addendum in August 2015 (NYSDEC, 2015b).

This report describes the performance and effectiveness monitoring of the on-site portion of the OU2 groundwater remedy (also referred to as the On-Site Containment [ONCT] system) for the Fourth Quarter 2017 (current period) and the Year 2017 (reporting period). As such, this report is the fourth quarter report for 2017 and is also the 2017 Annual Report and provides the basis to prepare an annual engineering certification of the ONCT system, as required by the OU2 AOC, and as warranted by evaluation of the data herein. In the report, the current period data was compared to data in the previous three 2017 quarterly reports issued by ARCADIS (2017b; 2017c; 2017d) and to longer-term data trends (also referred to as the period of record), as applicable.

This report does not summarize the activities conducted by the Navy at the former NWIRP property nor the ROD-required off-site components of the groundwater remedial program as these activities are managed and maintained by the Navy. The Navy activities include monitoring of the GM-38 hotspot, OM&M of the GM-38 groundwater extraction and treatment system, monitoring of VOC-impacted groundwater identified in the vicinity of Navy's Vertical Profile Borings (VPB) VBP-139 and VPB-142 (also referred to as the RE-108 hot spot), off-site groundwater investigation, and components of the public water supply protection program (i.e., additional outpost well installation and monitoring).

2 SITE OVERVIEW

This section provides a brief description of the Site, relevant history, main features/components, and describes the remedial action objectives (RAOs) specified in the OU2 ROD.

2.1 Description of Site

The former Grumman Aerospace Corporation (now the Northrop Grumman Systems Corporation) (NYSDEC Site # 1-30-003A) occupied approximately 600 acres in east-central Nassau County, in the Hamlet of Bethpage, Town of Oyster Bay, New York and within it was the NWIRP which occupied approximately 105 acres. The Site was bounded by Stewart Avenue to the north, South Oyster Bay Road to the west, Route 107 to the southwest, Central Avenue to the south, and various residential and commercial areas to the east. Currently, Northrop Grumman occupies and/or owns the parcels identified on **Figure 1**. The former Bethpage Naval Weapons Industrial Reserve Plant (NWIRP) (NYSDEC Site # 1-30-003B) site is located adjacent to the former Northrop Grumman site. Also the former Occidental Chemical Corporation (OXY)/Hooker Chemical Corporation/RUCO Polymer Corporation (referred to throughout this report as the OXY Site) (NYSDEC Site # 1-30-0004) site is located adjacent to and generally upgradient of the former Northrop Grumman site.

2.2 Nature and Extent of Impacted Groundwater

Groundwater sampling conducted as part of the Remedial Investigations (RIs) for the former Northrop Grumman, NWIRP, and OXY sites indicates that past chemical storage and/or waste disposal at each of these sites has resulted in impacts to groundwater (i.e., the upper glacial and Magothy aquifers). The primary groundwater constituents of concern (COCs), based on concentrations and frequency of detection, for the former Northrop Grumman and NWIRP sites are chlorinated volatile organic compounds (VOCs), mainly: trichloroethene (TCE); tetrachloroethene (PCE); 1,1,1-trichloroethane (1,1,1-TCA); 1,2-dichloroethene (1,2-DCE); 1,1-dichloroethene (1,1-DCE); and 1,1-dichloroethane (1,1-DCA). Groundwater associated with the former OXY site exhibits these COCs as well, with the addition of vinyl chloride monomer (VCM; also referred to herein as vinyl chloride). Metals are COCs in the groundwater near former Northrop Grumman Plants 1 and 2 (chromium and cadmium/chromium, respectively). The 1994 RI Report (Geraghty & Miller 1994) describes the overall extent (on-site and off-site) of groundwater impacts prior to remediation.

2.3 Remedial Action Objectives

The overall remedial goals for groundwater, as stated in the OU2 ROD, is to meet Standards, Criteria, and Guidance values (SCGs) and be protective of human health and the environment.

Consistent with the remedial goals selected for the Site, the remedial action objectives (RAOs) for OU2, either in whole or in part, are to:

- Eliminate, to the extent practicable, site-related constituents from the affected public water supplies and prevent, to the extent practicable, the future impacts to public water supplies.
- Eliminate, to the extent practicable, exposures to impacted groundwater.

- Eliminate, to the extent practicable, off-site migration of impacted groundwater and, where practicable, restore the groundwater to pre-disposal conditions.
- Eliminate, to the extent practicable, the off-site migration of soils impacts entering the groundwater.
- Eliminate, to the extent practicable, exceedances of applicable environmental quality standards related to releases of constituents to the waters of the state.
- Comply with applicable NYSDEC SCGs for OU2 ONCT system treated water and air. The discharge requirements for water and air are provided in the OM&M Manual (Arcadis 2014a).

2.4 Main Features/Components of the Remedy

Based on the OU2 ROD, and as presented on **Figures 2 and 3**, the following are the main features and components of the OU2 On-Site Groundwater Remedy, which is designed to actively remediate the on-site portion of the VOC-impacted groundwater:

- Operation, maintenance and monitoring of the OU2 ONCT system to address the on-site impacted groundwater. The OU2 ONCT system consists of:
 - Five Remedial Wells (1, 3R, 17, 18, and 19) with design (groundwater model-based) pumping rates of 800 gallons per minute (gpm), 700 gpm, 1,000 gpm, 600 gpm and 700 gpm, respectively. Remedial Well 3R was brought online in 2013 to replace Remedial Well 3 due to the declining specific capacity of Remedial Well 3
 - Two treatment systems (Tower 96 and Tower 102), each consisting of a packed tower air stripper to remove VOCs from the extracted groundwater and a regenerable vapor-phase granular activated carbon (RVPGAC) system, with on-site steam regeneration via on-site boilers, to remove VOCs from the air stripper off-gas emissions.
 - Supplemental air treatment at Tower 96, consisting of two vapor-phase granular activated carbon (VPGAC) polishing beds maintained by Northrop Grumman. Previously, treatment was provided by OXY, which had consisted of VPGAC and potassium permanganate-impregnated zeolite (PPZ). The OXY carbon unit was removed from service on January 26, 2017 and subsequently the PPZ was removed on March 23, 2017.
 - Two sets of recharge basins (the Southern Recharge Basins [primary] and the Western Recharge Basins [secondary]) to accept the treated water from the clear-well which drains by gravity to the basins.
 - A pressurized, discharge main to accept the treated water discharge and for limited non-potable reuse.
- A groundwater monitoring program to assess the overall OU2 On-Site Groundwater Remedy environmental effectiveness and a performance and compliance monitoring program at the treatment plants. The groundwater monitoring program also includes monitoring upgradient of public water supply wells. These wells were initially installed to serve as outpost wells and sampled in accordance with the Public Water Supply Contingency Plan (PWSCP) (Arcadis G&M, Inc., 2003a). However, these wells have served the purpose outlined in the PWSCP and were repurposed as plume

monitoring wells in 2015. The monitoring and former outpost wells included in Northrop Grumman's OU2 groundwater monitoring program, for which Northrop Grumman is responsible for reporting, and additional wells in the Site vicinity are shown on **Figure 1**. Monitoring or outpost wells for which Navy has responsibility for reporting are not shown on **Figure 1**.

3 OPERATION AND MAINTENANCE

The following subsections provide a summary of the routine and non-routine operation and maintenance activities completed during the 2017 reporting period to meet requirements outlined in the OM&M Manual (Arcadis 2014a), as well as a performance evaluation of the remedial treatment systems.

3.1 Summary of O&M Completed

The O&M of the ONCT system was conducted in accordance with the OU2 ONCT OM&M Manual (Arcadis 2014a), and consisted of the following:

- Daily site visits to visually check the system for proper operation, leaks, or other potential emergency situations. Additionally, the ONCT system was continuously monitored by the Supervisory Control and Data Acquisition (SCADA) system. Daily site visit logs are included in **Appendix A**.
- Weekly site checks by Northrop Grumman personnel to monitor and record key process parameters to confirm proper system operation, to assess whether a process parameter is changing, and to provide information that may be helpful later in case there is an operational problem. A summary of the weekly monitoring data collected for Tower 96 and Tower 102 is provided in **Tables 1A and 1B**, respectively.
- Routine maintenance by Northrop Grumman personnel of equipment was performed in accordance with the manufacturers' specifications, as needed, and per the OU2 ONCT OM&M Manual (Arcadis 2014a) routine maintenance schedule and checklist.
- Non-routine maintenance of equipment and system components was performed in response to alarm conditions, physical damage, or systems parameters operating outside of their normal operating ranges. A summary of the non-routine maintenance activities completed for Tower 96 and Tower 102 is provided in **Table 2**.
- Maintenance activities included scraping and sediment removal of the western most of the South Basins. During this time, the western basin was taken off line and the eastern and central basins along with the Western Basins (Outfall 006) were utilized for ONCT discharge. As reported in an email to the NYSDEC dated September 29, 2017, this maintenance was required to improve the basin infiltration rate for continued, effective long-term operation of the ONCT system. The pumping rates associated with Wells 17 through 19 were adjusted throughout the maintenance event based on storm water volumes and the ability of the central and eastern basins to accommodate flow from both storm water and Tower 102 ONCT effluent. In addition to draining the basin, other preparation activities, including repair of isolation valves and sluice gates, were necessary prior to the actual basin maintenance activities, which were conducted between November 27 and December 8, 2017.

- Solvent (also referred to as free product) recovered by the RVPGAC system, is characterized as a hazardous waste and was drummed, temporarily staged in a hazardous waste storage area, and properly transported and disposed of off-site by Northrop Grumman in accordance with applicable regulations. Copies of the completed hazardous waste manifests are included in **Appendix B**.

3.2 Performance Evaluation

The OU2 ONCT system operation in 2017 was consistent with operation in previous years. An operational summary of the remedial wells, discharges, and treatment system efficiencies for 2017 is provided in **Table 3** and summarized below:

- The remedial wells extracted a total of 1,942 million gallons (MG) of groundwater in 2017. The individual remedial wells pumped at the following percentages of their design volume: Remedial Well 1 (100%), Remedial Well 3R (104%), Remedial Well 17 (88%), Remedial Well 18 (113%), and Remedial Well 19 (87%). In general, the percentage of design volume less than 100% (i.e., Well 17 and Well 19) was due to pumping interruptions for routine and non-routine maintenance, particularly the need during the third and fourth quarters of 2017 to reduce flows to the South Basins to facilitate and perform necessary basin maintenance. The percentage of design volume for Well 3R was greater than 100% because its flow rate was increased in July 2014 and continued through the first quarter of the current report period to increase VOC mass removal from this remedial well. The percentage for Well 18 was greater than 100% because its flow rate was increased in February 2016 to increase mass removal due to atypical VOC results at Monitoring Well GM-21D2, which were evaluated in the 2016 Annual OM&M Report (Arcadis, 2017a). Specifically, during the first two quarters of 2017, Well 18 continued to be operated at a flow rate higher than design until the flow rate was adjusted back to design. Additional details regarding these changes, including the continued supplemental sampling of Monitoring Well GM-21D2, as recommended in the 2016 Annual OM&M Report (Arcadis, 2017a), are provided in **Appendix C**.
- During the third quarter and most of the fourth quarter of 2017, Wells 17, 18 and 19, on average, were operated at reduced flow rates compared to design to accommodate necessary maintenance of the western-most of the southern basins. On December 22, 2017, Northrop Grumman resumed normal flow rates for Wells 17, 18 and 19. Given the duration of operating Wells 17, 18 and 19 at reduced flow rates, the groundwater flow and solute transport model was used to confirm the effectiveness of the ONCT system in meeting its objective of on-site containment under these atypical conditions. This additional assessment is summarized in Section 4.2.3 with additional details provided in **Appendix G**.
- The OU2 ONCT system operated continuously in 2017, with the exception of brief shutdown periods for routine maintenance and alarm conditions. The remedial wells operated for the following “uptime” (calculated as a percentage of the reporting period): Remedial Well 1 (99%), Remedial Well 3R (99%), Remedial Well 17 (99%), Remedial Well 18 (99%), and Remedial Well 19 (99%).
- The water treatment components of the OU2 ONCT system (air stripper/clear well) performed within acceptable operating ranges for this reporting period, as indicated by the following:
 - The air stripper VOC removal efficiencies were greater than 99 percent.

- The air stripper effluent water discharges complied with applicable SCGs (**Table 4**). Additional details regarding system water monitoring are discussed in Section 4.
- The air treatment components of the OU2 ONCT system (RVPGAC/solvent recovery) performed within acceptable operating ranges during this reporting period. The RVPGAC stack discharges complied with applicable SCGs and discharge limits (**Tables 5A, 5B, 5C, 5D, 6A, and 6B**).
- Additional maintenance and assessment of the OU2 ONCT system's critical alarms and SCADA system set points was conducted during the reporting period and continued through March 2018. This effort was conducted to ensure that the alarms were functioning properly, would shut down the treatment systems in the event of an alarm condition, and that the set points were properly established in relation to the design criteria and current treatment system operating conditions.

4 MONITORING

This section provides a summary of the monitoring completed during the 2017 reporting period to meet requirements outlined in the OM&M Manual (Arcadis 2014a), the associated Updated Groundwater Monitoring Plan (Arcadis 2016a) and the PWSCP (Arcadis G&M, Inc., 2003a). The following subsections also provide summaries of 2017 monitoring data, comparisons of the results with applicable SCGs, and additional data evaluations describing the performance and effectiveness of the ONCT system, including a supplemental modeling assessment conducted to more fully evaluate ONCT system hydraulic effectiveness during the third and fourth quarters of 2017. Additionally, a subsection is included that provides a summary of the results from the wells originally associated with the ONCT Hydraulic Effectiveness Program and resulting interpretation. Finally, key findings are presented that support overall conclusions and suggested changes regarding monitoring for the Site.

4.1 Summary of Monitoring Completed

A summary of the monitoring completed in accordance with the above-referenced plans is provided below:

- Quarterly remedial system performance monitoring:
 - Remedial well water quality monitoring was completed to monitor the performance of the system and assess VOC mass removal. A summary of the VOC and 1,4-dioxane results are provided in **Table 17**. The compound 1,4-dioxane was added as an analyte to the sampling program consistent with NYSDEC's conditional approval (NYSDEC 2015b) of the June 2015 Groundwater Monitoring Plan Addendum (Arcadis 2015b). The method of analysis for 1,4-dioxane was changed from USEPA Method 8270D SIM to USEPA Method 522 during the Fourth Quarter 2016; 1,4-dioxane results are summarized in Section 4.2.5.5.
 - Water quality monitoring of the treatment systems effluent (Towers 96 and 102) was completed to monitor the performance of the water treatment components of the OU2 ONCT system. A summary of the VOC and 1,4-dioxane results is provided in **Table 4**. The compound 1,4-dioxane was added as an analyte to the sampling program consistent with NYSDEC's conditional approval (NYSDEC 2015b) of the June 2015 Groundwater Monitoring Plan Addendum (Arcadis 2015b). The method of analysis for 1,4-dioxane was changed from USEPA Method 8270D SIM to

2017 Annual Operation, Maintenance
and Monitoring Report
Operable Unit 2

USEPA Method 522 during the Fourth Quarter 2016; 1,4-dioxane results are summarized in Section 4.2.4.5.

- Remedial treatment systems air quality monitoring was completed to monitor the performance of the air treatment components of the OU2 ONCT system. A summary of the results is provided in **Tables 5A and 5B**.
- Remedial system compliance monitoring:
 - Monthly State Pollutant Discharge Elimination System (SPDES) monitoring was completed to verify water discharged to the Western Recharge Basins (i.e., Outfall 006) and Southern Recharge Basins (i.e., Outfall 005) met permit conditions. Monitoring was performed in accordance with the terms and conditions of Northrop Grumman's SPDES Permit No. NY0096792. A summary of the results is provided in **Table 7**. SPDES discharge monitoring data are documented monthly by Northrop Grumman in Discharge Monitoring Reports (DMRs) that are transmitted to the NYSDEC under separate cover. Copies of DMRs completed during this reporting period are provided in **Appendix D**.
 - Quarterly air monitoring and modeling was completed to determine the compliance status of the air discharges from the OU2 ONCT system. A summary of the results is provided in **Tables 5A/5B/5C/5D and 6A/6B**, respectively.
- Semi-annual groundwater hydraulic monitoring:
 - Groundwater hydraulic (water-level) monitoring was completed to determine, monitor, and document local and regional groundwater flow patterns resulting from the operation of the OU2 ONCT system, including the vertical and horizontal extent of the cumulative capture zone created by the operation of the OU2 ONCT system.
 - Routine hydraulic monitoring was performed on April 3 to April 11, 2017 (second quarter 2017) and October 10 to October 13, 2017 (fourth quarter 2017). **Tables 8 and 9** provide the water-level measurement data for the second and fourth quarters, respectively. As noted on these Tables, data for select Navy monitoring wells is included as supplemental information and as recommended in the 2016 Annual OM&M Report (Arcadis, 2017a).
- Groundwater quality monitoring:
 - Groundwater quality monitoring was completed to confirm the effectiveness of the OU2 ONCT system in removing impacted groundwater and preventing its off-site migration, while monitoring groundwater conditions in areas on and downgradient of the Site. Groundwater quality monitoring was performed quarterly for VOCs at outpost monitoring wells, semi-annually for VOCs and cadmium/chromium at select on-site and off-site wells (second and fourth quarters of 2017), and annually for VOCs at remaining on-site and off-site wells in the groundwater monitoring network (second quarter of 2017). The groundwater quality monitoring performed in 2017 incorporates modifications consistent with the Updated Groundwater Monitoring Plan (GWMP) (Arcadis 2016a). The compound 1,4-dioxane was added as an analyte to the monitoring well sampling program consistent with NYSDEC's conditional approval (NYSDEC 2015b) of the June 2015 Groundwater Monitoring Plan Addendum (Arcadis 2015b). The method of analysis for 1,4-dioxane was changed from USEPA Method 8270D SIM to USEPA Method 522 during the

Fourth Quarter 2016. Groundwater quality results are provided in **Tables 10 through 17**. Groundwater quality results associated with the first, second, and third quarters of 2017 have been previously submitted to NYSDEC in quarterly reports and are also included in this report, for completeness. Consistent with reporting during previous Annual Groundwater Monitoring Reports, copies of the completed Groundwater Sampling Logs and Chain of Custody Records are provided in **Appendix E**.

4.2 Summary of Monitoring Results

Results of monitoring completed during the reporting period are discussed in the following subsections and the data was and continues to be submitted to the NYSDEC on a quarterly basis, in electronic data deliverable (EDD) format that complies with NYSDEC requirements in the May 2010 DER-10, Section 1.15(a)2 (Electronic Submissions).

4.2.1 Remedial System Performance Monitoring

The OU2 ONCT system remedial well influent concentrations, VOC mass recovered, and VOC mass removal rates (**Tables 3, 4, and 13** and **Figures 4, 5, 6, 7 and 8**) are summarized below:

- Total volatile organic compound (TVOC) influent concentrations to the remedial wells ranged from 63 micrograms per liter ($\mu\text{g/L}$) (Remedial Well 18) to 750 $\mu\text{g/L}$ (Remedial Well 1) (**Table 4**). TCE, and PCE were the VOCs detected at the highest concentrations in all remedial wells, except for Well 19 where concentrations of TCE, and cis-1,2-Dichloroethene (cis-1,2-DCE) were the highest detected. With the exception of Remedial Wells 1 and 3R, the remedial wells have exhibited stable to decreasing TVOC trends since mid-2006 (**Figures 7 and 8**). Historical TVOC concentrations for Well 3 are shown on **Figure 7** to depict historical TVOC trends related to Well 3R, which replaced Well 3 in 2013.
- Vinyl Chloride Monomer (VCM) was detected in Remedial Well 3R but was not detected in the other remedial wells (**Table 4**). OXY is conducting remediation of groundwater (i.e., biosparge system) to address VCM upgradient (northwest) of Remedial Well 3R under the United States Environmental Protection Agency (USEPA) oversight.
- Approximately 5,000 lbs of TVOCs were removed from the aquifer and treated by the OU2 ONCT system (**Table 3** and **Figures 4, 5 and 6**). The majority of VOC mass was recovered by Remedial Well 1 (48 percent) and Remedial Well 3R (29 percent). The VOC mass removed in 2017 was less than the mass removed in 2016 due to reduced flow rates associated with basin maintenance as well as the continued downward trends in VOC influent concentrations.
- Since full-time startup of the ONCT system in November 1998, approximately 204,000 lbs of VOCs have been removed from the aquifer and treated by the ONCT system (**Table 3**).

4.2.2 Remedial System Compliance Monitoring

4.2.2.1 Water Discharge

The OU2 ONCT system's treated groundwater effluent met SPDES permit limits during the reporting period (**Table 7** and **Appendix D**), as indicated by the following:

- The measured concentration of individual VOCs in the treated water effluent were below applicable discharge limits.
- The measured concentrations of nitrogen and pH in the treated water effluent were below applicable discharge limits or ranges.

4.2.2.2 Air Discharge

Influent concentrations for the annual period were compared with the degree of cleaning required pursuant to 6NYCRR III A Part 212-2.3(b):

- As shown on **Table 5A**, concentrations of most compounds detected in Tower 96 Influent were less than 5,389 µg/m³ (concentration equivalent to 0.1 pounds per hour at a flow rate of 4,920 cubic feet per minute). For those compounds, air dispersion modeling is necessary to demonstrate that the maximum off-site air concentration is less than the NYSDEC DAR-1 annual guideline concentrations (AGC/SGC) values issued August 10, 2016. TCE, an A-rated compound, was detected at concentrations greater than 12,100 µg/m³ (0.22 pounds per hour) throughout the reporting period and requires 90% removal. Based on the influent and effluent TCE concentrations, the treatment system achieved TCE removal rates greater than 99%.
- As shown on **Table 5B**, concentrations of most compounds detected in Tower 102 Influent were less than 3,453 µg/m³ (concentration equivalent to 0.12 pounds per hour at a flow rate of 7,677 cubic feet per minute). For those compounds, air dispersion modeling is necessary to demonstrate that the maximum off-site air concentration is less than the NYSDEC DAR-1 AGC/SGC values issued August 10, 2016. TCE, an A-rated compound, was detected at concentrations greater than 3,990 µg/m³ (0.12 pounds per hour) for three of the four quarters during the reporting period and requires 90% removal. Based on the influent and effluent TCE concentrations, the treatment system achieved TCE removal rates greater than 99%.
- As shown on **Tables 5C and 5D** the maximum discharge amount of the A-rated compound Trichloroethene (500lb/year) was not exceeded during this period at Tower 96 or Tower 102, respectively.

The U.S. Environmental Protection Agency (USEPA) air quality dispersion model AERMOD was executed to estimate the highest ambient air concentration of the compounds on **Tables 5A/5B**. AERMOD is the USEPA's recommended best state-of-the-art practice Gaussian plume dispersion model. Gaussian models are the most widely used techniques for estimating the impact of non-reactive pollutants, per Appendix W of Title 40 Code of Federal Regulations (CFR) 51 – Guideline of Air Quality Models.

The following parameters were used for the AERMOD model analysis:

- Urban dispersion coefficients

2017 Annual Operation, Maintenance
and Monitoring Report
Operable Unit 2

- AERMAP base and terrain elevations, processed using National Elevation Dataset (NED) digitized terrain data
- Surface and upper air observations measured at the Nation Weather Service stations located at Farmingdale and Brookhaven airports for calendar years 2011-2015, in accordance with NYSDEC's DAR-10 Air Dispersion Modeling Guidance Document. This longer period of time was reviewed for the model run, to provide a conservative estimate of atmospheric impacts on the off-site concentrations.
- Receptor grids, per the following methodology:
 - For Tower 96 and Tower 102 receptors were located along the property boundary at distances not exceeding 25 meters.
 - For Tower 96, 1.5 km x 1.5 km Cartesian grid receptors with distances of 50 meters between the receptors and 3.0 km x 3.0 km Cartesian grid receptors with distances of 100 meters between the receptors.
 - For Tower 102, discrete receptors were located off-site at distances not exceeding 50 meters up to 500 meters from the plant boundary with additional off-site receptors placed at greater distances beyond 500 meters and discrete receptor spacing around the points of maximum predicted impacts did not exceed 50 meters.
- For Tower 96 and Tower 102 emission rates: 1 gram per second (g/s)

Based on the Tower 96 model output, the maximum one-hour ambient air impact was 148.05 [$\mu\text{g}/\text{m}^3$]/[g/s] and the maximum annual ambient air impact was 4.35 [$\mu\text{g}/\text{m}^3$]/[g/s]. **Table 6A** provides the compound specific scaled hourly ambient air impact and the scaled annual ambient air impact for the fourth quarter sampling event. As shown here for fourth quarter and previously in the first through third quarter reports for 2017 (Arcadis 2017b; Arcadis 2017c; Arcadis 2017d), the scaled ambient air impacts for Tower 96 are below the corresponding SGCs and AGCs.

Based on the Tower 102 model output, the maximum one-hour ambient air impact was 348.85 [$\mu\text{g}/\text{m}^3$]/[g/s] and the maximum annual ambient air impact was 2.29 [$\mu\text{g}/\text{m}^3$]/[g/s]. **Table 6B** provides the compound specific scaled hourly ambient air impact and the scaled annual ambient air impact for the fourth quarter sampling event. As shown here for fourth quarter and previously in the first through third quarter reports for 2017 (Arcadis 2017b; Arcadis 2017c; Arcadis 2017d), the scaled ambient air impacts for Tower 102 are below the corresponding SGCs and AGCs.

4.2.3 Hydraulic Monitoring and Groundwater Flow

In general, "mounding", as a result of the discharge of treated water to on-site recharge basins, is expected to be evident in the Shallow/Intermediate zones of the aquifer. Remedial well pumping generates "a cumulative cone of depression" (area of lowered water levels), which is expected to be most clearly evident in the Deep2 zone where the remedial wells are screened. Under these conditions, groundwater flow in the vicinity of the OU2 ONCT system is expected to be generally vertically downward from the shallower portions of the aquifer to the deeper portions of the aquifer toward the remedial wells.

2017 Annual Operation, Maintenance
and Monitoring Report
Operable Unit 2

In general, these expectations are being realized as documented in previous annual reports and as further discussion below for 2017.

Hydraulic monitoring was performed April 3 and April 11, 2017 (second quarter) and on October 10 and 13, 2017 (fourth quarter); **Tables 8 and 9** provide the water-level measurement data, respectively. **Table 18** summarizes vertical hydraulic gradients, for key monitoring well pairs in the vicinity of the OU2 ONCT system, which were calculated using the October 2017 water-level measurements and compares these gradients to groundwater model-predicted gradients (both direction and magnitude). In addition to the water level data collected as part of the Updated GWMP (2016c), water level data collected by Navy from Navy well clusters RE123 (RE123D1, RE123D2 and RE123D3) and RE126 (RE126D1, RE126D2 and RE126D3) were also added to **Table 8** and **Table 9**, as supplemental data, for analysis and interpretation. **Figures 9 and 10** depict groundwater elevations and flow directions in the Shallow/Intermediate zone and Deep2 (D2) zone, respectively, during operation of the OU2 ONCT system in October 2016.

Figure 9 shows that mounding of the water table exists in the Shallow/Intermediate zone, extending beneath the South Recharge Basins and across the former Northrop Grumman site southern boundary. Data summarized in **Table 18** indicate vertical hydraulic gradients are consistent with the expectations of vertical groundwater flow stated above. Additionally, the vertical gradients generally agree with the predominantly downward model-predicted gradients, with the few exceptions of well pairs GM-17SR/GM-17I, GM-21S/GM-21I and GM-39DA/GM-39DB where the field observed gradients are upward. Mounding and downward vertical gradients force shallower groundwater vertically downward into the Deep2 zone, where it is extracted by the ONCT remedial wells. **Figure 10** shows that the ONCT remedial wells have developed a cumulative zone of capture in the Deep2 zone that extends downgradient of the Site (see groundwater divide depicted on **Figure 10**), south of Monitoring Well GM-21D2.

It should be noted that during the fourth quarter 2017 hydraulic monitoring event, Remedial Wells 17, 18 and 19 were either operating at or below design flow rates (**Table 9**). The groundwater flow and solute transport model was used to confirm the effectiveness of the ONCT system in meeting its objective of on-site containment under these atypical conditions. In summary, the modeling effort considered the variability in remedial well flow rates over the third and fourth quarters to represent the impact that the changing pumping rates would have on groundwater flow and the resulting migration of the on-site portion of dissolved-phase VOCs. This was accomplished by transient flow solute transport modeling. At the end of the fourth quarter of 2017, the simulated steady-state capture zone (representing a return to normal flow rates on December 22, 2017) was superimposed on the transient flow solute transport modeling results to assess if on-site containment was achieved. **Figure 17** shows these results for several key model layers where the majority of remedial well pumpage occurs. As shown on this figure, the capture zone encompasses the on-site TVOC-impacts. More detailed information on this modeling assessment and a complete presentation of results is provided in **Appendix G**. The modeling assessment indicates the ONCT maintained vertical and horizontal control of VOC-impacted groundwater during the third and fourth quarters of 2017 and is preventing its off-site migration through hydraulic containment.

In summary, available 2017 hydraulic monitoring data indicate that the mounding, predominantly downward vertical gradients, and the Deep2 capture zone resulting from the operation of the OU2 ONCT

system creates a hydraulic barrier that prevents the off-site movement of VOC-impacted groundwater. The modeling assessment further supports this finding.

4.2.4 ONCT Hydraulic Effectiveness Program

Consistent with the OU2 ROD, Northrop Grumman conducted work in 2012 (Phase 1) and 2013 (Phase 2) under the “ONCT Hydraulic Effectiveness Program” to provide supplemental data to further evaluate and confirm that the ONCT system is performing effectively. The technical memorandum associated with Northrop Grumman’s On-Site Hydraulic Effectiveness Program was provided in **Appendix F** of the 2014 Periodic Review Report (Arcadis 2014c). This memorandum included a summary of the work performed, summary of the additional data (geologic, hydrogeologic, and groundwater quality) collected, and an interpretation regarding the effectiveness of the OU2 ONCT system in meeting its remedial objective (i.e., on-site containment of VOC-impacted groundwater). Interpretive figures were developed and included in the technical memorandum to support data evaluation and included profile-view figures in the vertical plane along the former Northrop Grumman site southern boundary that provided interpretations of: 1) TVOCs in groundwater, 2) groundwater flow, and 3) the geologic framework. Plan-view figures are included in the technical memorandum provided interpretations of TVOCs in the Deep, Deep2 and Deep3 zones.

For this report, these plan and profile view figures were updated with 2017 data collected by Northrop Grumman and supplemented with 2017 data collected by Navy and the Bethpage Water District to continue to evaluate and confirm that the ONCT system is performing effectively. A profile view figure (oriented in a north-south direction) was also prepared to further enhance the evaluation. **Figure 11** shows locations of cross-sections and the locations of monitoring wells and vertical profile borings used in this update. Profile-view **Figures 12** provide interpretations of: 1) TVOCs in groundwater, and 2) the geologic framework in the vertical plane along the former Northrop Grumman site southern boundary, perpendicular to the regional ambient groundwater flow direction. **Figure 13** provides an interpretation of TVOCs in groundwater and the geologic framework in the vertical plane oriented north-south from on-site to off-site, parallel to the regional ambient groundwater flow direction. Plan-view **Figures 14, 15 and 16** provide interpretations of TVOCs in the Deep, Deep2 and Deep3 zones. Supplemental groundwater quality data from the associated Navy wells and Bethpage Water District Plant 6 supply wells are provided in Tables F-1 through F-4 of **Appendix F**.

Key findings and conclusions from review of these updated interpretive figures are summarized below:

- Based on the west-east profile-view oriented along the former Northrop Grumman site southern boundary (**Figure 12**), groundwater quality in the deepest portion of the aquifer (basal Magothy) did not exhibit VOC concentrations in excess of applicable SCGs in the on-site area, with the exception of Monitoring Well GM-74D3 (as discussed below in Section 4.2.5.1.3). TVOC concentrations in groundwater below the base of the Magothy aquifer were less than 1 µg/L and did not exceed SCGs.
- North-south profile view **Figure 13** shows groundwater containing TVOCs at concentrations greater than 5 µg/L on-site and further downgradient, separated by a “clean water” front (i.e., TVOCs less than 5 µg/L). Deeper in the aquifer, **Figure 13** shows groundwater containing TVOC concentrations greater than 50 µg/L on-site and further downgradient, separated by TVOC concentrations less than

50 µg/L (but greater than 5 µg/L). Bifurcation of TVOC-impacted groundwater, and the associated “clean water” front will continue to develop downgradient of the ONCT system as on-site containment is maintained and VOC-impacted groundwater continues to be removed from the aquifer by pumping the remedial wells.

- For the Deep zone the bifurcation effect on the TVOC distribution (shown by separate 5 µg/L contour lines on and off-site) induced by continued pumping of the ONCT remedial well, is depicted on plan-view **Figure 14**. As pumping continues over time, bifurcation of TVOC-impacted groundwater, and the associated “clean water” front will continue to develop downgradient of the ONCT system as on-site containment is maintained and VOC-impacted groundwater continues to be removed from the aquifer by pumping the remedial wells.
- For the Deep2 zone, the bifurcation effect on the TVOC distribution (shown by separate 50 µg/L contour lines on and off-site) induced by continued pumping of the ONCT remedial wells is depicted on plan-view **Figure 15**. As pumping continues over time, bifurcation of TVOC-impacted groundwater, and the associated “clean water” front will continue to develop downgradient of the ONCT system as on-site containment is maintained and VOC-impacted groundwater continues to be removed from the aquifer by pumping the remedial wells. Also, as mentioned below in Section 4.2.5.1.2, the past increases in TVOCs at GM-21D2 followed by decreasing to stable trends supports the fact that onsite containment has been maintained.
- For the Deep3 zone, the bifurcation effect on the TVOC distribution (shown by separate 5 µg/L contour lines on and off-site) induced by continued pumping of the ONCT remedial wells is depicted on plan-view **Figure 16**. As pumping continues over time, bifurcation of TVOC-impacted groundwater, and the associated “clean water” front will continue to develop downgradient of the ONCT system as on-site containment is maintained and VOC-impacted groundwater continues to be removed from the aquifer by pumping the remedial wells.

In summary, evaluation of the 2017 data for this update confirms that the ONCT system provides effective vertical and horizontal hydraulic control of VOC-impacted groundwater and is preventing its off-site migration.

4.2.5 Groundwater Quality

This section describes and evaluates the analytical results of groundwater quality monitoring completed during 2017.

4.2.5.1 Volatile Organic Compounds

The evaluation of VOC monitoring results is presented by hydrogeologic zone and considers the following factors: (1) proximity to the hydraulic barrier formed by the OU2 ONCT system and (2) NYSDEC SCGs.

As on-site hydraulic containment continues and the off-site migration of VOCs is prevented, on- and off-site groundwater quality is improving over time. In the area, immediately south of the hydraulic barrier (i.e., the zone of hydraulic capture formed by the operation of the OU2 ONCT system), a “clean water” front is developing, which is causing bifurcation of the VOC impacts (i.e., development and growth of a

zone of groundwater with trace or no detectable VOCs downgradient of the former Northrop Grumman site southern boundary).

As mentioned above, results of the routine annual monitoring round and semi-annual monitoring round (second quarter and fourth quarter of 2017) were used to evaluate VOC groundwater quality for the reporting period. **Tables 10 through 14** summarize concentrations of VOCs during the annual groundwater monitoring round by hydrogeologic zone compared to applicable NYSDEC SCGs. Additionally, time-concentration graphs depicting the long-term VOC concentration trends in key wells (with detectable concentrations of VOCs that were sampled in 2017) grouped by proximity to the hydraulic barrier created by operation of the OU2 ONCT system are shown on **Figures 7, 8 and 18 through 22**.

4.2.5.1.1 *Shallow/Intermediate Zones*

As shown in **Tables 10 and 11**, shallow/intermediate monitoring wells located near or immediately downgradient of the former Northrop Grumman site southern boundary (GM-20I, GM-21S, GM-21I, GM-74I, GM-78S, GM-78I, and N-10631) did not exhibit exceedances of SCGs for VOCs in 2017. The groundwater quality data confirms that the operation of the OU2 ONCT system has formed an effective hydraulic barrier that prevents the off-site migration of VOC-impacted groundwater in the shallow/intermediate zone portion of the aquifer.

The majority of shallow/intermediate monitoring wells located on-site and upgradient of the former Northrop Grumman site southern boundary (FW-03, GM-15SR, GM-15I, GM-17I, GM-18I, HN-40S, HN-42S, and HN-42I) exhibited no VOC exceedances of SCGs in 2017 with the exception of GM-15SR which exhibited an exceedance for TCE during both the quarters of 2017. Also, HN-24I exhibited exceedances of SCGs for VOCs, including TCE and PCE. These two wells are located within the capture zone of the ONCT system; therefore, groundwater in this area is hydraulically contained and, over time, will be extracted and treated. Additionally, upgradient well HN-24I shows an overall decreasing TVOC concentration trend since startup of the OU2 ONCT system (**Figure 18**).

4.2.5.1.2 *Deep and Deep2 Zones*

2017 groundwater quality data indicate VOC SCG exceedances exist both on-site and in wells located further downgradient of the hydraulic barrier in the off-site portion of the VOC-impacted groundwater not actively remediated. However, an overall downward trend in VOC concentrations over time exists in Deep/Deep2 zone wells upgradient of the OU2 ONCT system and in off-site areas, further downgradient of the Site (more recent exceptions to this overall, historic trend are noted below, e.g., GM-79D, GM-37D, and GM-21D2). Data summarized in **Tables 12 and 13**, as well as VOC trend graphs depicted on **Figures 7, 8, 18, 19, 20 and 21** support these findings as follows:

- Well GM-13D is located on-site and upgradient of the OU2 ONCT system in the Deep zone (**Figure 1**). This well exhibits an overall downward trend in TVOC concentrations (**Figure 18**), with current concentrations representing a reduction in VOC concentrations of greater than 97 percent since the beginning of record (approximately one year after ONCT system startup).

2017 Annual Operation, Maintenance
and Monitoring Report
Operable Unit 2

- Deep zone monitoring wells located on-site along or upgradient of the former Northrop Grumman site southern boundary (e.g., GM-15D, GM-17D, GM-18D, GM-74D, and GM-39DA) and Deep zone monitoring wells located immediately downgradient of the former Northrop Grumman site southern boundary (e.g., Wells N-10627, GM-20D, and GM-21D) exhibited no SCG exceedances for VOCs during 2017. Monitoring well GM-79D, also located immediately downgradient and southeast of the former Northrop Grumman site in the Deep zone, exhibited SCG exceedances of TCE; however, the long-term trend in VOC concentrations remains downward in this well with the last two years showing a slight increasing trend (**Figure 19**). Monitoring well GM-37D, located further east of monitoring well GM-79D, also exhibited SCG exceedance of TCE for the fourth quarter 2017 and in increase in concentration similar to levels detected prior to 2004 (**Figure 19**). The recent increase in these two monitoring wells to the southeast/east of the former Northrop Grumman site may be indicative of groundwater impacts not related to Operable Unit 2.
- **Figure 7** depicts TVOC concentration trends for Deep2 zone wells along the southern and southwestern boundary of the former Northrop Grumman site. While exceedances of SCGs during 2017 are noted for monitoring wells GM-33D2 (TCE and Freon 113) and GM-73D2 (TCE) (**Table 13**), the overall long-term trends for these wells are downward with stable trends since approximately 2009 (**Figure 7**). Current concentrations in Wells GM-33D2 and GM-73D2 represent an approximate reduction in VOC concentrations of greater than 98 percent since 1999, and 96 percent since 2000, respectively.
- **Figure 8** depicts TVOC concentration trends for Deep and Deep2 zone wells along the southern and southeastern former Northrop Grumman site boundaries. While exceedances of SCGs during 2017 are noted for some of these Deep2 zone monitoring wells (**Table 13**), continued long-term trends are declining to relatively stable for these wells.
- **Figure 8** depicts TVOC concentration trends for Deep2 monitoring well GM-21D2, which is located just south of the former Northrop Grumman site southern boundary. GM-21D2 exhibited declining to stable trend throughout 2017 shown on **Figure 8**. Supplemental monthly monitoring of GM-21D2 continued to be conducted on a monthly frequency in 2017 to assess if TVOC trends remain stable as Well 18's flow rate was adjusted from 1,000 gpm to 800 gpm (late February 2017) and then again from 800 gpm to the design flow rate of 600 gpm (late June 2017). As shown in Appendix C, this supplemental monitoring of GM-21D2 confirmed TVOCs remained stable or decreased further as Well 18's flow rate was adjusted.
- **Figures 20 and 21** depict TVOC concentrations trends for Deep and Deep2 zone wells further downgradient of the Site to the southeast and to the south, respectively, in off-site areas of VOC-impacted groundwater that are not actively remediated. While exceedances of SCGs during 2017 are noted for some of these Deep and Deep2 zone monitoring wells (**Tables 12 and 13**), these wells continue to exhibit decreasing to stable TVOC concentration trends. In addition to Northrop Grumman owned wells, TVOC data from three Navy supplemental wells are also shown on **Figure 21** and **Figure 21A**. Monitoring Wells RE126D2, RE108D1 and RE108D2 are located directly downgradient of the Site to the south; concentrations trends for these three wells also exhibit overall decreasing TVOC concentrations.
- **Figure 22** depicts TVOC trends for Deep and Deep2 zone wells in the GM38 Area, located further downgradient and southeast of the Site. OM&M reports for the GM-38 Area Remedy are submitted to

2017 Annual Operation, Maintenance
and Monitoring Report
Operable Unit 2

NYSDEC by the Navy under separate cover. The TVOC concentrations in the off-site wells GM-38D and GM-38D2 have decreased since mid-2006 and 2002, respectively, except for an increase in TVOCs that was observed in GM-38D2 since late 2015 after Navy shut-down GM-38 system's Remedial Well RW-3 on July 1, 2015 and increased the Remedial Well RW-1 pumping rate from 800 gpm to 1000 gpm (H&S Environmental, 2016). Most recently through 2017, the concentrations appear to be stabilizing. In 2017, RW-1 pumping rate was maintained at 1,000 gpm and RW-3 was operated for one hour per month to maintain operational status and to allow for semi-annual sample collection (H&S Environmental, 2017; H&S Environmental, 2018).

In summary, the groundwater quality data from the Deep and Deep2 zone wells continues to support the interpretation of the hydraulic data and confirm that the operation of the OU2 ONCT system has formed an effective hydraulic barrier that prevents the off-site migration of VOC-impacted groundwater in the Deep and Deep2 zones and that groundwater quality off-site in the deeper portions of the aquifer is improving over time. VOC-impacted groundwater exceeding SCGs in on-site/upgradient wells is hydraulically contained and over time will be extracted and treated by the OU2 ONCT system. The continued decreases and stabilization in TVOCs at GM-21D2 as Well 18's flow rate was adjusted in 2017 also supports the above interpretation.

4.2.5.1.3 *Deep3 Zone*

Groundwater monitoring data from the Deep3 zone are summarized in **Table 14** and include monitoring wells installed on-site along the former Northrop Grumman site southern boundary as part of the ONCT Hydraulic Effectiveness Program (GM-73D3 and GM-74D3), which were formally added to the monitoring program consistent with the NYSDEC-approved Addendum (Arcadis 2015b). Results for the Deep3 zone wells are summarized as follows:

- Monitoring Well GM-73D3 did not exhibit SCG exceedances for VOCs (**Table 14**) which is consistent with sample results from 2016, previously provided as a part of the 2016 Annual OM&M Report (Arcadis 2017a).
- Monitoring Well GM-74D3 exhibited an SCG exceedance for TCE (**Table 14**) which is consistent with sample results from 2016 previously provided as a part of the 2016 Annual OM&M Report (Arcadis 2017a).

All VOCs, except TCE, do not exceed applicable SCGs in this deepest portion of the aquifer in the vicinity of the OU2 ONCT remedial wells confirming that the OU2 ONCT system is providing effective hydraulic containment in the Deep3 zone vertically to the base of the aquifer.

4.2.5.2 *Outpost Well Monitoring*

Starting fourth quarter 2015 outpost wells were repurposed as plume monitoring wells and also the method of analysis for VOCs was changed. The fourth quarter of 2015 represents the first event reflecting the change to semi-annual frequency and a change in the analytical method to USEPA Method 8260C for Target Compound List (TCL) VOCs. Starting second quarter 2016 samples from these outpost wells were analyzed for VOCs using USEPA Method 524.2 and for 1,4-dioxane using USEPA Method 522 as per email request from Navy dated May 2, 2016. Prior to the second quarter 2017 sampling round, Navy

completed well redevelopment activities on wells BPOW3-1 and BPOW3-2; the need for redevelopment of these wells (considerable silt accumulation) was identified in the fourth quarter of 2016. The results of the second and fourth quarter 2017 outpost well monitoring rounds, relative to applicable SCGs, are provided in **Table 15** for TCL VOCs. **Figures 23 through 26** are trend graphs for outpost wells through their period of record.

The complete descriptions of the procedures followed to collect groundwater samples from the outpost wells and to evaluate and document the results are provided in the PWSCP (ARCADIS G&M, Inc. 2003). Originally, there were a total of nine outpost monitoring wells (BPOW1-1, BPOW1-2, BPOW1-3, BPOW2-1, BPOW2-2, BPOW3-1, BPOW3-2, BPOW4-1, and BPOW4-2) with trigger values established for seven of the wells in accordance with the PWSCP. Currently there are a total of 15 outpost wells, and the six newest outpost monitoring wells (BPOW1-4, BPOW1-5, BPOW1-6, BPOW2-3, BPOW3-3, and BPOW3-4) did not have trigger values established. Outpost wells BPOW4-1 and BPOW4-2 were abandoned by the Navy in 2014 and replaced during the fourth quarter of 2014 with wells BPOW4-1R and BPOW4-2R at slightly different locations than the original wells but at similar depths. Sampling of these replacement wells as part of the outpost well groundwater monitoring program was initiated in 2015 to resume monitoring in this specific area.

Because trigger value exceedances have already been reported according to the PWSCP and as well head treatment has been installed at all four well fields monitored by the outpost wells, the original outpost wells have met the goal of the PWSCP (ARCADIS G&M, Inc. 2003) and they, along with the six new outpost wells, were re-purposed for use as plume monitoring wells, upon NYSDEC's conditional approval on August 25, 2015 of the June 2015 Groundwater Monitoring Plan Addendum (Arcadis 2015b). These outpost wells now provide data to evaluate trends in VOCs upgradient of the public water supply wells. Therefore, TVOC trigger values that had been previously established are no longer shown in **Table 15** and on **Figures 23 through 26**

Results for the year 2017 are compared to applicable SCGs as discussed below:

- VOCs were only detected above SCGs for VOCs in outpost wells BPOW 3-4, BPOW 4-1R, and BPOW 4-2R. **Figures 23, 24, 25 and 26** show TVOC trend graphs for the 15 outpost wells. Long term decreasing to stable trends are shown for outpost wells BPOW1-1, 1-2, 1-3, 1-4, 1-5, 1-6, 2-1, 2-2, 2-3, 3-1, 3-2, and 3-3. Long term increasing trends are shown for outpost wells BPOW3-4, BPOW4-1R, and BPOW 4-2R, although increased variability in results for BPOW4-1R and BPOW4-2R is noted for 2016 and 2017 as on **Figure 26**.

4.2.5.3 Cadmium and Chromium

Cadmium and chromium analytical results for the second quarter and fourth quarter of 2017 are provided in **Table 16**. Trends in total cadmium concentrations near former Northrop Grumman Plant 2 are shown on **Figure 27**. Trends in total chromium concentrations near former Northrop Grumman Plants 2 and 1 are shown on **Figures 28 and 29**, respectively. Results are summarized as follows:

2017 Annual Operation, Maintenance
and Monitoring Report
Operable Unit 2

- Exceedances of the SCG for cadmium were not detected in off-site monitoring wells GM-78S and GM-78I; however, exceedances of the SCG were noted in 2017 second quarter for on-site monitoring well N-10631 similar to concentrations detected in 2016. As shown on **Figure 27**, cadmium concentrations in N-10631 appear to be decreasing; there was no exceedance of the SCG for N-10631 for 2017 fourth quarter.
- Chromium did not exceed the SCG near the former Northrop Grumman Plant 2 in 2017 (**Figure 28**). Monitoring Wells GM-78S, GM-78I, and N-10631 continued to exhibit consistent decreasing or stable trends (**Figure 28**). Although Monitoring Well MW-02GF has shown variable concentrations for the period of record, including some results above the SCG, concentrations continue to be below the SCG since 2013.
- Since late 2010, the chromium concentration trend in PLT1MW-06, PLT1MW-05 and GM-15SR near the former Northrop Grumman Plant 1 have generally been stable (**Figure 29**). Apparent increases in chromium concentration in 2017 (PLT1MW-05) or decreases in chromium concentration in 2017 (GM-15SR) compared to 2016 are generally within the variability of concentrations observed over this period. These three monitoring wells continue to exhibit chromium concentrations in excess of the SCG in 2017. There have been no detections of chromium in Well PLT1MW-04 since mid-2005 (**Figure 29**).

4.2.5.4 Tentatively Identified Compounds

Consistent with reporting during previous Annual Groundwater Monitoring Reports, this section summarizes Tentatively Identified Compounds (TICs). Two unknown TICs was detected in former outpost wells BPOW2-1 and BPOW2-2 in the first quarter of 2017. One unknown TIC was detected in monitoring wells GM-71D2 and GM-74D3 in the second quarter of 2017. Two unknown TICs were detected in former outpost well BPOW 1-3 in the fourth quarter of 2017. TICs were not detected in any other monitoring wells during 2017.

4.2.5.5 1,4-Dioxane

As per the NYSDEC's conditional approval of the June 2015 Groundwater Monitoring Plan Addendum (NYSDEC 2015b), 1,4-dioxane was added as an analyte for all wells sampled under the OU2 groundwater monitoring program. Samples were analyzed for 1,4-dioxane using USEPA Method 522 in 2017. The results of 1,4-dioxane analysis of groundwater samples obtained from all four quarters of sampling are provided in **Table 17**.

Out of a total of 160 samples collected in 2017 from former outpost wells, monitoring wells, and remedial wells including replicates, 12 samples were non-detect. Detected concentrations ranged from 0.100 µg/L to 24.4 µg/L.

4.2.5.6 Vinyl Chloride Monomer

As mentioned previously, vinyl chloride monomer (VCM) was detected in Northrop Grumman Remedial Well 3R during the reporting period but was not detected in the other remedial wells. With respect to monitoring wells sampled during the reporting period, VCM was detected in only one monitoring well MW-3-1 at a concentration of 29.7 µg/L during the second quarter and 19.1 µg/L in the fourth quarter of 2017.

Groundwater remediation (i.e., biosparge system) to address VCM upgradient (northwest) of Remedial Well 3R and Monitoring Well MW-3-1 is currently underway by OXY under USEPA oversight.

4.2.5.7 QA/QC Samples and Data Validation

The results of analysis of QA/QC (field blank and trip blank) samples from the year 2017 is provided in **Table 19A** and **Table 19B**.

ARCADIS performed validation of treatment system vapor and water, and groundwater quality data in accordance with the Updated GWMP (Arcadis 2016c) and following the contract laboratory program and by applying relevant NYSDEC and USEPA protocols. The quality of the data is considered acceptable with the qualifiers indicated on **Tables 4, 5A/B, 7 and 10 through 17**.

5 CONCLUSIONS

The following conclusions are provided for the performance and ability of the OU2 ONCT system, to achieve the RAOs for the Site for the 2017 reporting period:

- The ONCT system is operating as designed and hydraulic containment of the on-site portion of the VOC-impacted groundwater continues.
- Shallow and intermediate wells on-site or near the southern boundary of the Northrop Grumman site exhibit few SCG exceedances.
- The water quality data from wells immediately downgradient of the hydraulic barrier have demonstrated downward trends over time and continue to show no or trace VOC concentrations.
- Groundwater quality data indicates that bifurcation of the VOC plume is continuing in the Deep, Deep2, and Deep3 zones south of the hydraulic barrier.
- Based on remedial well and system performance monitoring during the reporting period, the OU-2 ONCT groundwater extraction and treatment system operated as designed and extracted on-site contaminated groundwater to prevent it from migrating off-site. A supplemental modeling assessment was conducted to further support this conclusion, indicating on-site containment was maintained during the third and fourth quarters of 2017 when Remedial Wells 17, 18 and 19 were operating at reduced flow rates to prepare for and conduct necessary basin maintenance.
- The operation of the ONCT system complied with applicable NYSDEC SCGs for OU2 ONCT system emissions (i.e., treated water and air emissions).
- Cadmium and chromium impacts to groundwater from Plant 2 remain limited to on-site.
- Since late 2010, the chromium concentration trends in PLT1MW-06, PLTMW-05 and GM-15SR near the former Northrop Grumman Plant 1 have been stable.

6 SUGGESTIONS FOR CONTINUED MONITORING

Based on the findings and conclusions made in this report, the following suggestions are provided with respect to continued monitoring for ONCT system effectiveness:

2017 Annual Operation, Maintenance
and Monitoring Report
Operable Unit 2

- Since concentration trends have stabilized in GM-21D2 at or below Well 18's design flow rate, the sampling frequency of GM-21D2 will be reduced from monthly to quarterly starting in 2018. Quarterly monitoring of GM-21D2 in conjunction with supplemental quarterly monitoring of monitoring wells GM-20D, GM-33D2 and GM-75D2, which are also located just south of the ONCT remedial wells, will be conducted to confirm the results of the modeling assessment. Once confirmed that the VOC trends in these wells are consistent with the past and there are no deviations, the sampling will return to a semiannual frequency.
- Continue to enhance hydraulic and groundwater quality monitoring in the vicinity of the ONCT system by incorporating data obtained from Navy for monitoring well clusters RE-123 and RE-126 and to monitor for TVOC trends downgradient of the ONCT system capture zone, including the RE-108 area.

7 CERTIFICATION STATEMENT

For each institutional or engineering control identified for the OU2 On-Site Groundwater Remedy, I certify that all of the following statements are true:

- a. The engineering control employed for the OU2 On-Site Groundwater Remedy is unchanged from the date the control was put in place, or last approved by Division of Environmental Remediation (DER).
- b. Nothing has occurred that would impair the ability of such control to protect public health and the environment.
- c. Nothing has occurred that would constitute a violation or failure to comply with any operation, maintenance, and monitoring plan for this control.
- d. Access to the OU2 On-Site Groundwater Remedy will continue to be provided to DER to evaluate the remedy, including access to evaluate the continued maintenance of this control.

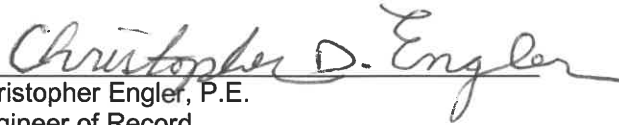

Christopher Engler, P.E.
Engineer of Record
New York License # 069748



8 REFERENCES

- Arcadis of New York, Inc. (Arcadis). 2017a. 2016 Annual Operation Maintenance and Monitoring Report Operable Unit 2, Northrop Grumman Systems Corporation, Bethpage, New York. March 2017.
- Arcadis of New York, Inc. (Arcadis). 2017b. First Quarter 2017 Operation Maintenance and Monitoring Report Operable Unit 2, Northrop Grumman Systems Corporation, Bethpage, New York. May 2017.
- Arcadis of New York, Inc. (Arcadis). 2017c. Second Quarter 2017 Operation Maintenance and Monitoring Report Operable Unit 2, Northrop Grumman Systems Corporation, Bethpage, New York. August 2017.
- Arcadis of New York, Inc. (Arcadis). 2017d. Third Quarter 2017 Operation Maintenance and Monitoring Report Operable Unit 2, Northrop Grumman Systems Corporation, Bethpage, New York. November 2017.
- Arcadis of New York, Inc. (Arcadis) 2016a. Updated Groundwater Monitoring Plan, Operable Unit 2 Northrop Grumman and NWIRP Sites, Bethpage, New York, NYSDEC Site #s 1-30-003A and B, June 2016.
- Arcadis of New York, Inc. (Arcadis) 2015 a. Groundwater Monitoring Plan, Operable Unit 2 – Northrop Grumman and NWIRP Sites, Bethpage, New York, NYSDEC Site #s 1-30-003A and B, June 2015.
- Arcadis of New York, Inc. (Arcadis) 2015b. Final Groundwater Monitoring Plan Addendum, Operable Unit 2 – Northrop Grumman and NWIRP Sites, Bethpage, New York, NYSDEC Site #s 1-30-003A and B, October 2015.
- Arcadis of New York, Inc. (Arcadis). Arcadis of New York, Inc. (ARCADIS). 2014a. Operation, Maintenance, and Monitoring Manual, On-Site Groundwater Containment System, Operable Unit 2 – Northrop Grumman and NWIRP Sites, Bethpage, New York, NYSDEC Site #s 1-30-003A and B, May 2014.
- Arcadis of New York, Inc. (Arcadis) Arcadis. 2014b. Groundwater Monitoring Plan, Operable Unit 2 – Northrop Grumman and NWIRP Sites, Bethpage, New York, NYSDEC Site #s 1-30-003A and B, May 2014.
- Arcadis of New York, Inc. (Arcadis). 2014c. 2013 Periodic Review Report, On-Site Groundwater Remedy, Operable Unit 2, Northrop Grumman Systems Corporation, Bethpage, New York NYSDEC Site # 1-30-003A Naval Weapons Industrial Reserve Plant, Bethpage, New York, NYSDEC Site# 1-30-003B. October 2014.
- Arcadis G&M, Inc. 2003a. Public Water Supply Contingency Plan, Naval Facilities Engineering Command. July 22, 2003.

2017 Annual Operation, Maintenance
and Monitoring Report
Operable Unit 2

Arcadis G&M, Inc. 2003b. Operable Unit 2 Remedial System Hydraulic Effectiveness Evaluation. May 5, 2003.

Geraghty & Miller. 1994. Remedial Investigation Report, Grumman Aerospace Corporation, Bethpage, New York. September 26, 1994.

H&S Environmental Inc. Groundwater Treatment Plant GM-38 Area Groundwater Remediation Naval Weapons Industrial Reserve Plant, Bethpage, New York. January 2018.

H&S Environmental Inc. Groundwater Treatment Plant GM-38 Area Groundwater Remediation Naval Weapons Industrial Reserve Plant, Bethpage, New York. December 2017.

H&S Environmental Inc. Groundwater Treatment Plant GM-38 Area Groundwater Remediation Naval Weapons Industrial Reserve Plant, Bethpage, New York. February 2016.

New York State Department of Environmental Conservation (NYSDEC). 2015a. Order on Consent and Administrative Settlement, Operable Unit 2, site # 130003A, April 21, 2015.

NYSDEC. 2015b. Letter to Northrop Grumman System Corporation. RE: Groundwater Monitoring Plan Addendum, Operable Unit 2, Northrop Grumman Systems Corporation and Naval Weapons Industrial Reserve Plant (NWIRP) sites, Bethpage, New York (NYSDEC Sites # 130003A and B). August 25, 2015.

NYSDEC. 2016. DAR-1 AGC/SGC Tables, Revised August 10, 2016

NYSDEC. 2001. Record of Decision, Operable Unit 2 Groundwater, Northrop Grumman and Naval Weapons Industrial Reserve Plant Sites, Nassau County, Site Numbers 1-30-003A & B, March 29, 2001.

TABLES



Table 1A
Summary of Weekly Monitoring Data ^(1,2) 2017,
Tower 96 Treatment System, Operable Unit 2,
Northrop Grumman Systems Corporation,
Bethpage, New York

Date	WELL 1				WELL 3R					AIR STRIPPER			Ambient Influent Air Temperature (°F)
	Extracted Groundwater			VFD	Extracted Groundwater			VFD		Influent Water Flow			
	Flow Rate (gpm)	Totalizer (x1000) (gal)	Pressure (psig)	Frequency (Hz)	Flow Rate (gpm)	Totalizer (x1000) (gal)	Pressure (psig)	Frequency (Hz)	Amperage (Amps)	Flow Recorder Rate (gpm)	Flow Meter Rate (gpm)	Totalizer (x100) (gal)	
1/17/2017	854	1,952,369	51	51.45	981	156,874	34	51.59	91.6	1,785	1,787	2,908,883	64
2/14/2017	856	2,287,207	51	51.40	982	192,840	34	51.70	92.4	1,782	1,787	3,579,017	67
3/21/2017	760	2,668,992	42	47.63	708	228,813	30	43.14	72.6	1,418	1,424	4,298,677	44
4/18/2017	810	2,982,454	47	49.28	710	257,179	30	43.21	72.8	1,470	1,469	4,878,463	56
5/23/2017	807	3,388,089	47	49.08	709	292,664	30	43.01	72.4	1,470	1,468	5,615,613	62
6/21/2017	807	3,723,175	47	49.07	708	322,125	30	43.01	72.4	1,472	1,473	6,225,793	74
7/17/2017	805	4,025,803	47	49.14	709	348,692	30	43.25	72.9	1,467	1,464	6,777,769	76
8/14/2017	806	4,351,307	47	49.32	710	377,177	30	43.22	72.7	1,563	1,565	7,367,296	69
9/18/2017	806	4,757,387	47	49.06	719	414,503	30	43.49	73.2	1,484	1,482	8,120,658	67
10/24/2017	807	5,175,827	47	49.13	718	451,841	30	43.80	74.1	1,474	1,476	8,892,705	71
11/14/2017	804	5,421,196	47	49.13	719	473,440	30	43.67	73.7	1,483	1,483	9,335,652	64
12/19/2017	806	6,815,897	47	48.98	719	508,545	32	43.50	73.3	1,474	1,475	10,057,680	68

Notes and Abbreviations on last page.

Table 1A
Summary of Weekly Monitoring Data ^(1,2) 2017,
Tower 96 Treatment System, Operable Unit 2,
Northrop Grumman Systems Corporation,
Bethpage, New York

Date	HEAT EXCHANGER		PROCESS BLOWER				CONDENSER		
	Air Inlet Pressure (iwc)	Steam Inlet Pressure (psig)	Air Inlet Pressure (iwc)	Air Effluent Temperature (°F)	Air Effluent Pressure (iwc)	Blower Static Pressure (iwc)	Condenser Cooling Water		
							Influent Temperature (°F)	Effluent Temperature (°F)	Temperature Differential (°F)
1/17/2017	-5.3	12	-5.2	86	2.2	7.4	56	80	24
2/14/2017	-5.5	11	-5.3	85	2.2	7.5	--	--	NC
3/21/2017	-4.9	11	-5.2	86	2.0	7.2	--	--	NC
4/18/2017	-5.0	10	-5.2	88	2.0	7.2	--	--	NC
5/23/2017	-5.1	10	-5.5	96	2.1	7.6	56	81	25
6/21/2017	-4.8	10	-5.2	90	2.2	7.4	56	81	25
7/17/2017	-4.9	10	-5.1	94	2.0	7.1	NM	NM	NC
8/14/2017	-4.9	15	-5.1	91	2.2	7.3	57	82	25
9/18/2017	-4.6	13	-4.9	91	2.1	7.0	NM	NM	NC
10/24/2017	-5.1	13	-5.0	90	2.2	7.2	NM	NM	NC
11/14/2017	-4.0	13	-4.9	90	2.3	7.2	NM	NM	NC
12/19/2017	-4.0	13	-5.1	90	2.0	7.1	54	80	26

Notes and Abbreviations on last page.

Table 1A
Summary of Weekly Monitoring Data ^(1,2) 2017,
Tower 96 Treatment System, Operable Unit 2,
Northrop Grumman Systems Corporation,
Bethpage, New York

Date	SEPARATOR			AIR COMPRESSOR	SUPPLEMENTAL AIR TREATMENT SYSTEM		WEST RECHARGE BASINS			
	Condensed Steam Water				Influent Blower	Total System Effluent	North		South	
	Separator Temperature (°F)	Separator Vent Temperature (°F)	Observed Flow Rate (gpm)	Delivery Pressure (psig)	Pressure (iwc)	Pressure (iwc)	Basin Water Height (ft)	Status (On/Off)	Basin Water Height (ft)	Status (On/Off)
1/17/2017	87	95	0	86	-2.4	5	5.0	On	8.0	On
2/14/2017	90	106	0	86	-2.4	5	5.0	On	8.5	On
3/21/2017	--	--	--	86	-2.5	5	5.5	On	10.5	On
4/18/2017	--	--	--	86	-2.5	6	5.0	On	9.0	On
5/23/2017	77	110	NM	86	-2.5	5	4.8	On	9.6	On
6/21/2017	75	100	NM	86	-2.5	5	5.8	On	9.8	On
7/17/2017	NM	NM	NM	86	-2.5	5	6.0	On	10.5	On
8/14/2017	82	105	NM	86	-2.5	5	5.5	On	8.5	On
9/18/2017	NM	NM	NM	86	-2.4	5	6.5	On	10.5	On
10/24/2017	NM	NM	NM	86	-2.5	5	6.0	On	10.0	On
11/14/2017	NM	NM	NM	86	-2.5	5	6.8	On	10.8	On
12/19/2017	NM	95	NM	86	-2.5	5	7.5	On	11.8	On

Notes and Abbreviations on last page.

Table 1A
Summary of Weekly Monitoring Data ^(1,2) 2017,
Tower 96 Treatment System, Operable Unit 2,
Northrop Grumman Systems Corporation,
Bethpage, New York

Date	REGENERATIVE VAPOR PHASE TREATMENT UNITS									
	Adsorb				Desorb					
	Flow (cfm)	Pressure (iwc)	Temperature (°F)	Flow (scfm)	Desorb Bed (A/B)	Time into cycle (min)	Influent Steam Temperature ⁽³⁾ (°F)	Influent Steam Pressure (psig)	Effluent Steam Temperature (°F)	Effluent Temperature (°F)
1/17/2017	4,860	0.00	98	4,616	Bed B	51	216	15	195	82
2/14/2017 ⁽⁴⁾	4,990	0.00	NM	NC	--	--	--	--	--	--
3/21/2017 ⁽⁴⁾	5,000	0.00	96	4,766	--	--	--	--	--	--
4/18/2017 ⁽⁴⁾	5,200	0.09	96	4,958	--	--	--	--	--	--
5/23/2017	4,800	0.33	96	4,579	Bed A	39	251	10	184	64
6/21/2017	4,800	0.60	92	4,615	Bed A	32	241	11	171	90
7/17/2017	4,810	NM	94	NC	Bed A	36	248	10	NM	94
8/14/2017	4,800	0.25	97	4,570	Bed B	56	246	12	183	90
9/18/2017	4,813	NM	97	NC	Bed B	33	247	13	NM	90
10/24/2017	4,775	NM	97	NC	Bed A	30	239	13	NM	90
11/14/2017	4,700	0.52	94	4,502	Bed B	30	245	12.5	NM	90
12/19/2017	4,900	0.15	98	4,656	Bed B	41	236	11.5	147	90

Notes and Abbreviations on last page.

Table 1A
Summary of Weekly Monitoring Data ^(1,2) 2017,
Tower 96 Treatment System, Operable Unit 2,
Northrop Grumman Systems Corporation,
Bethpage, New York

Notes and Abbreviations:

(1)	Operational data collected weekly by Northrop Grumman and supplemented by monthly Arcadis measurements. Readings shown for days noted or nearest monthly Arcadis visit.
(2)	Instantaneous values from field-mounted instruments, except otherwise noted.
(3)	Measurement taken with Infrared temperature gun.
--	Not Applicable
°F	degrees Fahrenheit
Amps	amperes
cfm	cubic feet per minute
ft	feet
gal	gallons
gpm	gallons per minute
Hz	hertz
iwc	inches of water column
psig	pounds per square inch, gauge
scfm	standard cubic feet per minute
NA	Not Available
NC	Not Calculated
NM	Not Measured
RVPGAC	Regenerative Vapor Phase Granular Activated Carbon
VFD	Variable Frequency Drive

Table 1B
 Summary of Weekly Monitoring Data^(1,2) 2017
 Tower 102 Treatment System, Operable Unit 2,
 Northrop Grumman Systems Corporation,
 Bethpage, New York

Date	WELL 17					WELL 18					WELL 19				
	Extracted Groundwater				VFD	Extracted Groundwater				VFD	Extracted Groundwater				VFD
	Flow Recorder Rate (gpm)	Flow Meter Rate (gpm)	Totalizer (x1000) (gal)	Pressure (psig)	Frequency (Hz)	Flow Recorder Rate (gpm)	Flow Meter Rate (gpm)	Totalizer (x1000) (gal)	Pressure (psig)	Frequency (Hz)	Flow Recorder Rate (gpm)	Flow Meter Rate (gpm)	Totalizer (x1000) (gal)	Pressure (psig)	Frequency (Hz)
1/17/2017	1,006	1,004	1,017,991	64	53.2	1,021	1,020	477,859	68	54.5	702	704	1,081,172	61	48.1
2/14/2017	1,002	1,003	1,058,367	64	53.2	1,018	1,025	518,902	68	54.1	701	703	1,109,407	60	48.6
3/21/2017	992	992	1,108,434	59	52.0	818	822	560,489	62	48.7	654	658	1,142,274	56	46.3
4/18/2017	1,004	1,002	1,148,322	60	52.1	817	821	593,229	63	48.5	695	704	1,169,336	58	47.3
5/23/2017	1,001	1,002	1,198,505	60	52.1	818	820	633,996	63	48.4	701	706	1,204,411	58	47.0
6/21/2017	1,006	1,003	1,240,007	60	52.0	817	820	667,907	62	48.5	709 ⁽⁴⁾	--	1,232,808 ⁽⁴⁾	58	47.3
7/17/2017	1,001	1,002	1,277,433	53	50.9	516	519	693,221	54	42.0	609 ⁽⁴⁾	610	1,258,647 ⁽⁴⁾	48	44.0
8/14/2017	893	893	1,311,990	50	47.9	516	519	714,409	52	41.5	624 ⁽⁴⁾	600	1,282,533 ⁽⁴⁾	47	43.5
9/18/2017	506	504	1,345,311	41	39.1	516	519	740,627	46	39.9	512	514	1,310,524 ⁽⁴⁾	40	40.5
10/24/2017	1,001	1,001	1,394,188	51	50.7	514	516	767,826	52	41.6	509	510	1,336,985 ⁽⁴⁾	46	42.0
11/14/2017	504	504	1,412,456	41	39.0	516	518	783,091	46	39.8	510	509	1,352,112 ⁽⁴⁾	40	40.5
12/19/2017 ⁽⁵⁾	406	404	1,439,923	37	36.1	416	419	807,942	42	37.1	418	413	1,372,243 ⁽⁴⁾	36	37.5

Notes and Abbreviations on last page.

Table 1B
Summary of Weekly Monitoring Data^(1,2) 2017
Tower 102 Treatment System, Operable Unit 2,
Northrop Grumman Systems Corporation,
Bethpage, New York

Date	AIR STRIPPER						HEAT EXCHANGER			
	Influent Water Flow					Ambient Influent Air Temperature (°F)	Air Inlet Temperature (°F)	Steam Inlet Pressure (psig)	Air Outlet Temperature (°F)	Calculated Temperature Differential (°F)
	Flow Recorder Rate (gpm)	Flow Meter Rate (gpm)	Totalizer (x1000) (gal)	Influent Water Temperature (°F)	Influent Water Pressure (psig)					
1/17/2017	2,495	--	32,841,470	58	34	56	60	32	78	18
2/14/2017	2,701	2,696	33,920,348	57	32	68	59	32	78	19
3/21/2017	2,438	2,437	35,151,432	58	30	61	60	32	78	18
4/18/2017	2,494	2,492	36,137,700	59	31	68	59	32	81	22
5/23/2017	2,491	2,494	37,382,278	59	31	64	60	32	80	20
6/21/2017	2,502	2,505	38,413,349	59	31	68	60	32	80	20
7/17/2017	2,089	2,091	39,289,650	59	31	60	60	32	84	24
8/14/2017	1,971	1,971	40,074,792	59	27	70	60	32	78	18
9/18/2017	1,498	1,497	40,922,869	59	34	67	60	32	82	22
10/24/2017	1,988	1,989	41,937,550	60	30	70	60	32	80	20
11/14/2017	1,476	1,478	42,410,234	59	27	60	60	32	81	21
12/19/2017	1,194	1,193	43,115,359	58	27	60	60	32	82	22

Notes and Abbreviations on last page.

Table 1B
 Summary of Weekly Monitoring Data^(1,2) 2017
 Tower 102 Treatment System, Operable Unit 2,
 Northrop Grumman Systems Corporation,
 Bethpage, New York

Date	PROCESS BLOWER TO RVPGAC TREATMENT UNITS				CONDENSER				AIR COMPRESSOR
	Blower Influent Pressure (iwc)	VIV Position (% open)	Blower Effluent Pressure (iwc)	Calculated Blower Static Pressure (iwc)	Cooling Water			Condensed Steam Water	Delivery Pressure (psig)
					Influent Temperature ⁽⁴⁾ (°F)	Effluent Temperature ⁽⁴⁾ (°F)	Calculated Temperature Increase (°F)	Decanter Vent Temperature (°F)	
1/17/2017	-7.2	100	24.5	-31.7	58	81	23	89	122
2/14/2017	-7.2	100	24.0	-31.2	58	87	29	88	120
3/21/2017	-7.0	100	24.5	-31.5	58	74	16	80	122
4/18/2017	-7.2	100	25.0	-32.2	58	79	21	76	122
5/23/2017	-7.0	100	25.0	-32.0	59	89	30	83	120
6/21/2017	-7.0	100	25.0	-32.0	59	88	29	99	110
7/17/2017	-6.0	100	25.0	-31.0	59	82	23	83	112
8/14/2017	-6.5	100	25.0	-31.5	59	72	13	76	110
9/18/2017	-6.5	100	25.0	-31.5	59	78	19	82	114
10/24/2017	-6.8	100	25.0	-31.8	60	80	20	76	112
11/14/2017	-6.5	100	26.0	-32.5	59	82	23	80	114
12/19/2017	-6.2	100	26.0	-32.2	58	88	30	92	110

Notes and Abbreviations on last page.

Table 1B
 Summary of Weekly Monitoring Data^(1,2) 2017
 Tower 102 Treatment System, Operable Unit 2,
 Northrop Grumman Systems Corporation,
 Bethpage, New York

Date	T102 VAPOR DISCHARGE		T102 WEIR		FORCE MAIN	REGENERATIVE VAPOR PHASE TREATMENT UNITS					
	Effluent Treated Vapor		Effluent Treated Groundwater			Desorb					
	Flow (cfm)	Temperature (°F)	Flow Meter Rate (gpm)	Totalizer (x1000) (gal)		Distribution System Pressure (psig)	Desorb Bed (A/B)	Time Into Cycle (min)	Influent Steam Pressure (psig)	Influent Steam Temperature (°F)	Desorb Bed Temperature (°F)
1/17/2017	7,640	94	2,631	380,326	57.1	Bed B	36	3.3	228	160	193
2/14/2017	7,860	98	2,710	470,240	64.0	Bed A	138	3.1	248	172	205
3/21/2017	8,030	90	1,846	561,749	66.8	Bed A	30	3.2	250	160	201
4/18/2017	8,180	93	2,454	636,770	58.9	Bed B	34	3.1	248	151	203
5/23/2017	7,800	92	2,450	751,503	62.5	Bed A	35	3.2	258	162	203
6/21/2017	7,680	96	2,022	849,010	64.6	Bed B	127	3.1	249	173	201
7/17/2017	7,950	92	1,505	922,873	64.7	Bed A	36	3.1	224	170	202
8/14/2017	8,111	82	1,220	978,268	65.5	Bed B	34	3.3	251	146	203
9/18/2017	8,100	83	850	30,845	66.7	Bed B	40	3.3	257	160	202
10/24/2017	8,001	84	1,245	90,330	67.0	Bed B	30	3.5	242	152	202
11/14/2017	8,130	91	786	113,985	68.6	Bed A	30	3.6	244	160	196
12/19/2017	8,080	86	507	152,424	67.0	Bed B	37	3.2	249	158	204

Notes and Abbreviations on last page.

Table 1B
Summary of Weekly Monitoring Data^(1,2) 2017
Tower 102 Treatment System, Operable Unit 2,
Northrop Grumman Systems Corporation,
Bethpage, New York

Notes and Abbreviations:

- (1) Operational data collected weekly by Northrop Grumman and supplemented by monthly Arcadis measurements. Readings shown are for days noted or nearest monthly Arcadis visit.
- (2) Instantaneous values from field-mounted instruments, except otherwise noted.
- (3) Measurement taken with Infrared temperature gun.
- (4) Readings obtained for these dates from SCADA.
- (5) On December 22, 2017, pumping rates for Well 17, Well 18 and Well 19 returned to design rates of 1,000 gpm, 600 gpm and 700 gpm, respectively.

--	Parameter not collected/recorded
°F	degrees Fahrenheit
cfm	cubic feet per minute
ft	feet
gal	gallons
gpm	gallons per minute
iwc	inches of water column
min	minutes
psig	pounds per square inch, gauge
scfm	standard cubic feet per minute
NA	Not Analyzed
NC	Not Calculated
SCADA	Supervisory Control and Data Acquisition
T102	Tower 102
RVPGAC	Regenerative Vapor Phase Granular Activated Carbon
VIV	variable influent vane
VFD	Variable Frequency Drive

Table 2
Summary of Non-Routine Maintenance, 2017,
ONCT Treatment System, Operable Unit 2
Northrop Grumman Systems Corporation,
Bethpage, New York

Date Completed	Maintenance Item ⁽¹⁾	Description/Comments
01/26/17	GAC Changeout	Carbon installation at former occidental beds (Supplemental once through carbon beds)
06/15/17	SCADA Flow Updates	SCADA modifications. Weir flow troubleshooting
06/30/17	Boiler Insulation	Boiler insulation work
11/30/17	T96 Carbon	Carbon installation at former occidental beds (Supplemental once through carbon beds)
12/14/17	T102 Discharge pressure gauge	New discharge pressure gauge installed

Notes and Abbreviations:

- (1) Maintenance items were completed, as necessary, based on observations of the treatment system during the routine daily and weekly site visits.
- GAC Granular Activated Carbon
- SCADA Supervisory Control and Data Acquisition
- T96 Tower 96 treatment system
- T102 Tower 102 treatment system

Table 3

Operational Summary for the On-Site Portion of the OU2 Groundwater Remedy, Fourth Quarter and Annual 2017⁽¹⁾ Reporting Periods
 Operable Unit 2, Northrop Grumman Systems Corporation,
 Bethpage, New York

	Quarterly Flow Rates (gpm)		Quarterly Flow Volumes (MG)			Annual Flow Volumes (MG)			Quarterly VOC Concentrations (µg/L)		VOC Mass Removed (lbs) ⁽⁷⁾		
	Design ⁽²⁾	Average ^(3,4)	Design ⁽²⁾	Actual ^(3,4)	% of Design	Design ⁽²⁾	Actual ^(3,4)	% of Design	TCE ⁽⁵⁾	TVOC ^(5,6)	Quarterly	Annual	Cumulative
Influent Groundwater													
Well 1 ⁽¹¹⁾	800	807	107.1	107.0	100%	420.5	421.0	100%	608	650	581	2,366	45,979
Well 3R ⁽¹¹⁾	700	709	93.7	94.0	100%	367.9	383.0	104%	362	410	322	1,448	90,589
Well 17 ^(11,12)	1,000	732	133.9	96.0	72%	525.6	462.0	88%	116	150	120	561	53,027
Well 18 ^(11,12)	600	511	80.4	66.0	82%	315.4	357.0	113%	45	68	38	197	6,369
Well 19 ^(11,12)	700	495	93.7	65.0	69%	367.9	319.0	87%	118	140	76	407	8,380
Total⁽¹³⁾	3,800	3,254	509	428	84%	1,997	1,942	97%	--	--	1,137	4,979	204,344
Effluent Groundwater⁽⁸⁾													
Calpine	100 - 400	174	--	22.6	--	--	111.7	--	--	--	--	--	--
OXY Biosparge ⁽¹⁰⁾	2 - 42	0	--	0	--	--	0.0	--	--	--	--	--	--
West Recharge Basins	1,112 - 1,455	1,979	--	265.0	--	--	960.0	--	--	0.6	--	--	--
South Recharge Basins ⁽¹²⁾	2,231	1,045	298.8	140.0	47%	1,172.6	870.0	74%	--	1.3	--	--	--
Total⁽¹⁴⁾	--	3,198	--	428	--	--	1,942	--	--	--	--	--	--
Additional Flow to South Recharge Basins													
Storm Water Runoff Contributing to South Recharge Basins Flow Volume ⁽¹⁴⁾	--	--	--	19.1	--	--	71.1	--	--	--	--	--	--
Total Flow Volume to South Recharge Basins^(12,14,15)	--	--	299	159	53%	1,175.8	941.1	80%	--	--	--	--	--
Treatment Efficiencies⁽⁹⁾													
Tower 96 System:	>99.9%												
Tower 102 System:	>99.9%												

Notes and abbreviations on last page.

Table 3

Operational Summary for the On-Site Portion of the OU2 Groundwater Remedy, Fourth Quarter and Annual 2017⁽¹⁾ Reporting Periods
 Operable Unit 2, Northrop Grumman Systems Corporation,
 Bethpage, New York



Notes and Abbreviations:

- (1) Quarterly reporting period: October 02, 2017 through January 03, 2018. Annual reporting period: January 3, 2017 through January 3, 2018
- (2) "Design" flow rates were determined for the five remedial wells and for the South Recharge Basins based on computer modeling (ARCADIS G&M, Inc. 2003c, modified in April 2005). Flow rates for Calpine, OXY Biosparge and West Recharge Basins are typical flow rates and are provided for reader information. "Design" flow volumes represent the volume of water that should be pumped/discharged during the reporting period and is calculated by multiplying the design rate by the reporting period duration.
- (3) "Average" flow rates for the remedial wells represent the average actual pumping rates when the pumps are operational and do not take into account the time that a well is not operational. During this quarterly reporting period, the remedial wells operated for the following percentage of the time: Well 1 (99%), Well 3R (99%), Well 17 (97.9%), Well 18 (96.4%), and Well 19 (98%). During this annual reporting period, the remedial wells operated for the following percentage of the time: Well 1 (99.5%), Well 3R (99.5%), Well 17 (99.2%), Well 18 (98.8%), Well 19 (99%). "Actual" volumes are determined via totaled values computed by SCADA using the instantaneous flow rates transmitted from local flow meters.
- (4) "Average" flow rates for the system discharges represent the average flow rate during the entire reporting period and are determined by dividing the total flow during the reporting period by the reporting period duration. The Calpine and South Recharge Basins flow volumes are determined via totaled values computed by SCADA using the instantaneous flow rates transmitted from local flow meters. December Calpine flow valves obtained through analogue meter readings as digital meter signal was disrupted intermittently through the month. The West Recharge Basin flow is calculated by subtracting the cumulative flow to the other discharges from the total influent flow. Actual flow to the recharge basins is greater, as shown, because storm water combines with the plant effluent prior to discharge to the recharge basins.
- (5) The TCE and TVOC concentrations for the remedial wells are from the quarterly sampling event performed during this reporting period on December 13, 2017.
- (6) The TVOC concentration for the two sets of recharge basins are their respective average monthly SPDES concentration for the current quarter.
- (7) TVOC mass removed for the reporting period is calculated by multiplying the TVOC concentration from the quarterly sampling event and the quantity of water pumped during the reporting period.
- (8) There are four discharges for the effluent groundwater: South Recharge Basins, West Recharge Basins, Calpine and OXY Biosparge system. Treated water is continuously discharged to the south and west recharge basins, and is available "on-demand" to both the Calpine Power Plant (Calpine) for use as make-up water, and the biosparge remediation system operated by Occidental Chemical (OXY Biosparge).
- (9) Treatment System Efficiencies are calculated by dividing the difference between the remedial well flow weighted influent and effluent TVOC concentrations by the remedial well flow weighted influent concentration.
- (10) Occidental Chemical has not reported any water usage for the OXY Biosparge system since May 2016.
- (11) The downtime during Fourth Quarter 2017 was minor and due to typical operation and maintenance. See Note 12 for detail on reduced percent design flow values.
- (12) As reported in an email to the NYSDEC dated September 29, 2017, during the third and fourth quarter the pumping rates were adjusted at Wells 17 through 19 to accommodate draining the western most of the South Basins for a comprehensive basin scraping and rehabilitation work. Rainfall events would dictate the increase or decreases in pumping needed to maintain draining of the western most of the South Basins. Average pumping rates and modified South basin recharge rates are shown above.
- (13) Total pumpage/recharge rates are accurate to ±15% due to limitations in metering.
- (14) Storm Water Runoff Volume is calculated by multiplying the adjusted tributary area and NOAA precipitation data for the reporting periods. The adjusted tributary area is tributary area that is adjusted by the runoff coefficient to exclude the infiltration volume from the total rainfall volume. The tributary area, runoff coefficient, and adjusted tributary area are from Dvirka and Bartilucci Consulting Engineers' Storm Water Permit Evaluation Report (January, 28, 2010). The NOAA precipitation data are calculated as a sum of NOAA daily precipitation data for the reporting period. NOAA precipitation data are retrieved from Station GHCND:USW00054787 - FARMINGDALE REPUBLIC AIRPORT, NY US.
- (15) Total Flow Volume to South Recharge Basins is estimated as a sum of flow volumes contributed from the Effluent Groundwater to South Recharge Basins and from Storm Water Runoff to South Recharge Basins.

--	Not Applicable	NOAA	National Oceanic and Atmospheric Administration
µg/L	micrograms per liter	SCADA	Supervisory Controls and Data Acquisition
gpm	gallons per minute	SPDES	State Pollution Discharge Elimination System
lbs	pounds	TCE	trichloroethene
MG	million gallons	TVOC	total volatile organic compounds
		VOC	volatile organic compounds

Table 4
Concentrations of Constituents in Remedial Wells and
Treatment System Effluents, 2017, Operable Unit 2,
Northrop Grumman Systems Corporation,
Bethpage, New York

Constituents ⁽¹⁾ (units in µg/L)	Location ID:	WELL 1	WELL 1	WELL 1	WELL 1
	Sample ID:	WELL 1	WELL 1	WELL 1	WELL 1
	Sample Date:	2/22/2017	6/27/2017	9/12/2017 ⁽⁵⁾	12/13/2017
Volatile Organic Compounds (VOCs)⁽²⁾					
	NYSDEC SCGs ⁽³⁾				
1,1,1-Trichloroethane	5	0.35 J	0.32 J	<4.0	0.35 J
1,1,2,2-Tetrachloroethane	5	<1.0	<1.0	<4.0	<1.0
1,1,2-Trichloroethane	5	<1.0	<1.0	<4.0	<1.0
1,1-Dichloroethane	5	0.73 J	0.86 J	<4.0	0.77 J
1,1-Dichloroethene	5	2.7	3.3	<4.0	2.7
1,2-Dichloroethane	5	<1.0	<1.0	<4.0	<1.0
1,2-Dichloropropane	5	4.5	4.7	4.4	4.4
2-Butanone (MEK)	50	<10	<10	<40	<10
2-Hexanone (MBK)	50	<5.0	<5.0	<20	<5.0
4-methyl-2-pentanone (MIK)	50	<5.0	<5.0	<20	<5.0
Acetone	50	<10	<10	<40	<10
Benzene	1	<0.50	<0.50	<2.0	<0.50
Bromodichloromethane	50	<1.0	<1.0	<4.0	<1.0
Bromoform	50	<1.0	<1.0	<4.0	<1.0
Bromomethane	5	<2.0	<2.0	<8.0	<2.0
Carbon Disulfide	50	<2.0	<2.0	<8.0	<2.0
Carbon Tetrachloride	5	<1.0	<1.0	<4.0	<1.0
Chlorobenzene	5	<1.0	<1.0	<4.0	<1.0
Chloroethane	5	<1.0	<1.0	<4.0	<1.0
Chloroform	7	0.32 J	0.32 J	<4.0	0.35 J
Chloromethane	5	<1.0	<1.0	<4.0	<1.0
cis-1,2-Dichloroethene	5	4.8	5.7	4.9	5.3
cis-1,3-Dichloropropene	5	<1.0	<1.0	<4.0	<1.0
Dibromochloromethane	5	<1.0	<1.0	<4.0	<1.0
Ethylbenzene	5	<1.0	<1.0	<4.0	<1.0
Methylene Chloride	5	<2.0	<2.0	<8.0	<2.0
Styrene	5	<1.0	<1.0	<4.0	<1.0
Tetrachloroethene	5	28.1	22.4	21.7	22.4
Toluene	5	<1.0	<1.0	<4.0	<1.0
trans-1,2-Dichloroethene	5	<1.0	<1.0	<4.0	<1.0
trans-1,3-Dichloropropene	5	<1.0	<1.0	<4.0	<1.0
Trichloroethylene	5	702	622	603	608
Trichlorotrifluoroethane (Freon 113)	5	4.3 J	4.1 J	<20	3.8 J
Vinyl Chloride	2	<1.0	<1.0	<4.0	<1.0
Xylene-o	5	<1.0	<1.0	<4.0	<1.0
Xylene-m,p	5	<1.0	<1.0	<4.0	<1.0
Total VOCs⁽⁴⁾		750	660	630	650
1,4-Dioxane⁽²⁾	NS	8.91	9.78	9.35	9.09

Notes and abbreviations on last page.

Table 4
Concentrations of Constituents in Remedial Wells and
Treatment System Effluents, 2017, Operable Unit 2,
Northrop Grumman Systems Corporation,
Bethpage, New York

Constituents ⁽¹⁾ (units in µg/L)	Location ID: Sample ID: Sample Date:	WELL 3R WELL 3R 2/14/2017	WELL 3R WELL 3R 6/27/2017	WELL 3R WELL 3R 9/12/2017 ⁽⁵⁾	WELL 3R WELL 3R 12/13/2017
Volatile Organic Compounds (VOCs)⁽²⁾					
	NYSDEC SCGs ⁽³⁾				
1,1,1-Trichloroethane	5	0.78 J	0.61 J	0.68 J	0.68 J
1,1,1,2-Tetrachloroethane	5	<1.0	<1.0	<1.0	<1.0
1,1,1,2-Trichloroethane	5	<1.0	<1.0	<1.0	<1.0
1,1-Dichloroethane	5	1.4	1.6	1.5	1.5
1,1-Dichloroethene	5	4.9	4.8	4.1	4.1
1,2-Dichloroethane	5	<1.0	<1.0	<1.0	<1.0
1,2-Dichloropropane	5	<1.0	<1.0	<1.0	<1.0
2-Butanone (MEK)	50	<10	<10	<10	<10
2-Hexanone (MBK)	50	<5.0	<5.0	<5.0	<5.0
4-methyl-2-pentanone (MIK)	50	<5.0	<5.0	<5.0	<5.0
Acetone	50	<10	<10	<10	<10
Benzene	1	<0.50	<0.50	<0.50	<0.50
Bromodichloromethane	50	<1.0	<1.0	<1.0	<1.0
Bromoform	50	<1.0	<1.0	<1.0	<1.0
Bromomethane	5	<2.0	<2.0	<2.0	<2.0
Carbon Disulfide	50	<2.0	<2.0	<2.0	<2.0
Carbon Tetrachloride	5	<1.0	<1.0	<1.0	<1.0
Chlorobenzene	5	<1.0	<1.0	<1.0	<1.0
Chloroethane	5	<1.0	<1.0	<1.0	<1.0
Chloroform	7	<1.0	<1.0	<1.0	<1.0
Chloromethane	5	<1.0	<1.0	<1.0	<1.0
cis-1,2-Dichloroethene	5	4.3	4.6	4.3	4.3
cis-1,3-Dichloropropene	5	<1.0	<1.0	<1.0	<1.0
Dibromochloromethane	5	<1.0	<1.0	<1.0	<1.0
Ethylbenzene	5	<1.0	<1.0	<1.0	<1.0
Methylene Chloride	5	<2.0	<2.0	<2.0	<2.0
Styrene	5	<1.0	<1.0	<1.0	<1.0
Tetrachloroethene	5	30.9	27.1	30.5	27.8
Toluene	5	<1.0	<1.0	<1.0	<1.0
trans-1,2-Dichloroethene	5	<1.0	<1.0	<1.0	<1.0
trans-1,3-Dichloropropene	5	<1.0	<1.0	<1.0	<1.0
Trichloroethylene	5	498	397	365	362
Trichlorotrifluoroethane (Freon 113)	5	4.0 J	3.8 J	3.5 J	3.5 J
Vinyl Chloride	2	3.9	3.5	2.7	2.1
Xylene-o	5	<1.0	<1.0	<1.0	<1.0
Xylene-m,p	5	<1.0	<1.0	<1.0	<1.0
Total VOCs⁽⁴⁾		550	440	410	410
1,4-Dioxane⁽²⁾	NS	16.4	15.8	14.9	16.8

Notes and abbreviations on last page.

Table 4
Concentrations of Constituents in Remedial Wells and
Treatment System Effluents, 2017, Operable Unit 2,
Northrop Grumman Systems Corporation,
Bethpage, New York

Constituents ⁽¹⁾ (units in µg/L)	Location ID: Sample ID: Sample Date:	96 EFFLUENT 96 EFFLUENT 2/14/2017	96 EFFLUENT 96 EFFLUENT 6/27/2017	96 EFFLUENT 96 EFFLUENT 9/12/2017 ⁽⁵⁾	96 EFFLUENT 96 EFFLUENT 12/13/2017
<u>Volatile Organic Compounds (VOCs)⁽²⁾</u>					
	NYSDEC SCGs ⁽³⁾				
1,1,1-Trichloroethane	5	<1.0	<1.0	<1.0	<1.0
1,1,2,2-Tetrachloroethane	5	<1.0	<1.0	<1.0	<1.0
1,1,2-Trichloroethane	5	<1.0	<1.0	<1.0	<1.0
1,1-Dichloroethane	5	<1.0	<1.0	<1.0	<1.0
1,1-Dichloroethene	5	<1.0	<1.0	<1.0	<1.0
1,2-Dichloroethane	5	<1.0	<1.0	<1.0	<1.0
1,2-Dichloropropane	5	<1.0	<1.0	<1.0	<1.0
2-Butanone (MEK)	50	<10	<10	<10	<10
2-Hexanone (MBK)	50	<5.0	<5.0	<5.0	<5.0
4-methyl-2-pentanone (MIK)	50	<5.0	<5.0	<5.0	<5.0
Acetone	50	<10	<10	<10	<10
Benzene	1	<0.50	<0.50	<0.50	<0.50
Bromodichloromethane	50	<1.0	<1.0	<1.0	<1.0
Bromoform	50	<1.0	<1.0	<1.0	<1.0
Bromomethane	5	<2.0	<2.0	<2.0	<2.0
Carbon Disulfide	50	<2.0	<2.0	<2.0	<2.0
Carbon Tetrachloride	5	<1.0	<1.0	<1.0	<1.0
Chlorobenzene	5	<1.0	<1.0	<1.0	<1.0
Chloroethane	5	<1.0	<1.0	<1.0	<1.0
Chloroform	7	<1.0	<1.0	<1.0	<1.0
Chloromethane	5	<1.0	<1.0	<1.0	<1.0
cis-1,2-Dichloroethene	5	<1.0	<1.0	<1.0	<1.0
cis-1,3-Dichloropropene	5	<1.0	<1.0	<1.0	<1.0
Dibromochloromethane	5	<1.0	<1.0	<1.0	<1.0
Ethylbenzene	5	<1.0	<1.0	<1.0	<1.0
Methylene Chloride	5	<2.0	<2.0	<2.0	<2.0
Styrene	5	<1.0	<1.0	<1.0	<1.0
Tetrachloroethene	5	<1.0	<1.0	<1.0	<1.0
Toluene	5	<1.0	<1.0	<1.0	<1.0
trans-1,2-Dichloroethene	5	<1.0	<1.0	<1.0	<1.0
trans-1,3-Dichloropropene	5	<1.0	<1.0	<1.0	<1.0
Trichloroethylene	5	1.2	<1.0	<1.0	<1.0
Trichlorotrifluoroethane (Freon 113)	5	<5.0	<5.0	<5.0	<5.0
Vinyl Chloride	2	<1.0	<1.0	<1.0	<1.0
Xylene-o	5	<1.0	<1.0	<1.0	<1.0
Xylene-m,p	5	<1.0	<1.0	<1.0	<1.0
Total VOCs⁽⁴⁾		1.2	0.0	0.0	0.0
1,4-Dioxane⁽²⁾	NS	11.1	10.9	12.2	12.6

Notes and abbreviations on last page.

Table 4
Concentrations of Constituents in Remedial Wells and
Treatment System Effluents, 2017, Operable Unit 2,
Northrop Grumman Systems Corporation,
Bethpage, New York

Constituents ⁽¹⁾ (units in µg/L)	Location ID: Sample ID: Sample Date:	WELL 17 WELL 17 2/14/2017	WELL 17 WELL 17 6/29/2017	WELL 17 WELL 17 9/12/2017 ⁽⁵⁾	Well 17 REP-091217-MG-1 9/12/2017 ⁽⁵⁾
<u>Volatile Organic Compounds (VOCs)⁽²⁾</u>					
	NYSDEC SCGs ⁽³⁾				
1,1,1-Trichloroethane	5	0.28 J	<1.0	0.25 J	0.27 J
1,1,2,2-Tetrachloroethane	5	<1.0	<1.0	<1.0	<1.0
1,1,2-Trichloroethane	5	<1.0	<1.0	<1.0	<1.0
1,1-Dichloroethane	5	0.89 J	0.95 J	0.86 J	0.85 J
1,1-Dichloroethene	5	1.9	1.8	1.7	1.7
1,2-Dichloroethane	5	<1.0	<1.0	<1.0	<1.0
1,2-Dichloropropane	5	<1.0	<1.0	0.27 J	0.24 J
2-Butanone (MEK)	50	<10	<10	<10	<10
2-Hexanone (MBK)	50	<5.0	<5.0	<5.0	<5.0
4-methyl-2-pentanone (MIK)	50	<5.0	<5.0	<5.0	<5.0
Acetone	50	<10	<10	<10	<10
Benzene	1	<0.50	<0.50	<0.50	<0.50
Bromodichloromethane	50	<1.0	<1.0	<1.0	<1.0
Bromoform	50	<1.0	<1.0	<1.0	<1.0
Bromomethane	5	<2.0	<2.0	<2.0	<2.0
Carbon Disulfide	50	<2.0	<2.0	<2.0	<2.0
Carbon Tetrachloride	5	<1.0	<1.0	<1.0	<1.0
Chlorobenzene	5	<1.0	<1.0	<1.0	<1.0
Chloroethane	5	<1.0	<1.0	<1.0	<1.0
Chloroform	7	0.24 J	<1.0	<1.0	<1.0
Chloromethane	5	<1.0	<1.0	<1.0	<1.0
cis-1,2-Dichloroethene	5	2.8	3.0	2.8	2.9
cis-1,3-Dichloropropene	5	<1.0	<1.0	<1.0	<1.0
Dibromochloromethane	5	<1.0	<1.0	<1.0	<1.0
Ethylbenzene	5	<1.0	<1.0	<1.0	<1.0
Methylene Chloride	5	<2.0	<2.0	<2.0	<2.0
Styrene	5	<1.0	<1.0	<1.0	<1.0
Tetrachloroethene	5	23.3	22.0	21.6	21.4
Toluene	5	<1.0	<1.0	<1.0	<1.0
trans-1,2-Dichloroethene	5	<1.0	<1.0	<1.0	<1.0
trans-1,3-Dichloropropene	5	<1.0	<1.0	<1.0	<1.0
Trichloroethylene	5	116	116	105	104
Trichlorotrifluoroethane (Freon 113)	5	3.3 J	3.4 J	2.8 J	2.9 J
Vinyl Chloride	2	<1.0	<1.0	<1.0	<1.0
Xylene-o	5	<1.0	<1.0	<1.0	<1.0
Xylene-m,p	5	<1.0	<1.0	<1.0	<1.0
Total VOCs⁽⁴⁾		150	150	140	130
1,4-Dioxane⁽²⁾	NS	8.74	7.48	8.51	8.21

Notes and abbreviations on last page.

Table 4
Concentrations of Constituents in Remedial Wells and
Treatment System Effluents, 2017, Operable Unit 2,
Northrop Grumman Systems Corporation,
Bethpage, New York

Constituents ⁽¹⁾ (units in µg/L)	Location ID: Sample ID: Sample Date:	WELL 17 WELL 17 12/13/2017	Well 17 REP-121317-MG-1 12/13/2017	WELL 18 WELL 18 2/14/2017	WELL 18 REP-021417-SN-1 2/14/2017
Volatile Organic Compounds (VOCs)⁽²⁾					
	NYSDEC SCGs ⁽³⁾				
1,1,1-Trichloroethane	5	0.29 J	0.28 J	0.43 J	0.43 J
1,1,1,2-Tetrachloroethane	5	<1.0	<1.0	<1.0	<1.0
1,1,2-Trichloroethane	5	<1.0	<1.0	<1.0	<1.0
1,1-Dichloroethane	5	0.91 J	0.94 J	1.2	1.1
1,1-Dichloroethene	5	1.8	1.9	<1.0	1.3
1,2-Dichloroethane	5	<1.0	<1.0	<1.0	<1.0
1,2-Dichloropropane	5	<1.0	0.28 J	<1.0	<1.0
2-Butanone (MEK)	50	<10	<10	<10	<10
2-Hexanone (MBK)	50	<5.0	<5.0	<5.0	<5.0
4-methyl-2-pentanone (MIK)	50	<5.0	<5.0	<5.0	<5.0
Acetone	50	<10	<10	<10	<10
Benzene	1	<0.50	<0.50	<0.50	<0.50
Bromodichloromethane	50	<1.0	<1.0	<1.0	<1.0
Bromoform	50	<1.0	<1.0	<1.0	<1.0
Bromomethane	5	<2.0	<2.0	<2.0	<2.0
Carbon Disulfide	50	<2.0	<2.0	<2.0	<2.0
Carbon Tetrachloride	5	<1.0	<1.0	<1.0	<1.0
Chlorobenzene	5	<1.0	<1.0	<1.0	<1.0
Chloroethane	5	<1.0	<1.0	<1.0	<1.0
Chloroform	7	<1.0	<1.0	<1.0	<1.0
Chloromethane	5	<1.0	<1.0	<1.0	<1.0
cis-1,2-Dichloroethene	5	3.0	2.9	2.1	2.2
cis-1,3-Dichloropropene	5	<1.0	<1.0	<1.0	<1.0
Dibromochloromethane	5	<1.0	<1.0	<1.0	<1.0
Ethylbenzene	5	<1.0	<1.0	<1.0	<1.0
Methylene Chloride	5	<2.0	<2.0	<2.0	<2.0
Styrene	5	<1.0	<1.0	<1.0	<1.0
Tetrachloroethene	5	21.8	21.6	13.0	12.1
Toluene	5	<1.0	<1.0	<1.0	<1.0
trans-1,2-Dichloroethene	5	<1.0	<1.0	<1.0	<1.0
trans-1,3-Dichloropropene	5	<1.0	<1.0	<1.0	<1.0
Trichloroethylene	5	116	116	46.1	45.0
Trichlorotrifluoroethane (Freon 113)	5	3.3 J	3.4 J	1.3 J	1.2 J
Vinyl Chloride	2	<1.0	<1.0	<1.0	<1.0
Xylene-o	5	<1.0	<1.0	<1.0	<1.0
Xylene-m,p	5	<1.0	<1.0	<1.0	<1.0
Total VOCs⁽⁴⁾		150	150	64	63
1,4-Dioxane⁽²⁾	NS	10.5	11.2	7.24	6.67

Notes and abbreviations on last page.

Table 4
Concentrations of Constituents in Remedial Wells and
Treatment System Effluents, 2017, Operable Unit 2,
Northrop Grumman Systems Corporation,
Bethpage, New York

Constituents ⁽¹⁾ (units in µg/L)	Location ID: Sample ID: Sample Date:	WELL 18 WELL 18 6/27/2017	WELL 18 REP-062417-JB-1 6/27/2017	WELL 18 WELL 18 9/12/2017 ⁽⁵⁾	WELL 18 WELL 18 12/13/2017
<u>Volatile Organic Compounds (VOCs)⁽²⁾</u>					
	NYSDEC SCGs ⁽³⁾				
1,1,1-Trichloroethane	5	0.44 J	0.57 J	0.42 J	0.51 J
1,1,2,2-Tetrachloroethane	5	<1.0	<1.0	<1.0	<1.0
1,1,2-Trichloroethane	5	<1.0	<1.0	<1.0	<1.0
1,1-Dichloroethane	5	1.3	1.5	1.2	1.4
1,1-Dichloroethene	5	4.0	4.4	3.1	3.4
1,2-Dichloroethane	5	<1.0	<1.0	<1.0	<1.0
1,2-Dichloropropane	5	<1.0	<1.0	<1.0	<1.0
2-Butanone (MEK)	50	<10	<10	<10	<10
2-Hexanone (MBK)	50	<5.0	<5.0	<5.0	<5.0
4-methyl-2-pentanone (MIK)	50	<5.0	<5.0	<5.0	<5.0
Acetone	50	<10	<10	<10	<10
Benzene	1	<0.50	<0.50	<0.50	<0.50
Bromodichloromethane	50	<1.0	<1.0	<1.0	<1.0
Bromoform	50	<1.0	<1.0	<1.0	<1.0
Bromomethane	5	<2.0	<2.0	<2.0	<2.0
Carbon Disulfide	50	<2.0	<2.0	<2.0	<2.0
Carbon Tetrachloride	5	<1.0	<1.0	<1.0	<1.0
Chlorobenzene	5	<1.0	<1.0	<1.0	<1.0
Chloroethane	5	<1.0	<1.0	<1.0	<1.0
Chloroform	7	<1.0	<1.0	<1.0	<1.0
Chloromethane	5	<1.0	<1.0	<1.0	<1.0
cis-1,2-Dichloroethene	5	2.7	3.3	2.7	2.7
cis-1,3-Dichloropropene	5	<1.0	<1.0	<1.0	<1.0
Dibromochloromethane	5	<1.0	<1.0	<1.0	<1.0
Ethylbenzene	5	<1.0	<1.0	<1.0	<1.0
Methylene Chloride	5	<2.0	<2.0	<2.0	<2.0
Styrene	5	<1.0	<1.0	<1.0	<1.0
Tetrachloroethene	5	11.9	16.7	13.8	13.9
Toluene	5	<1.0	<1.0	<1.0	<1.0
trans-1,2-Dichloroethene	5	<1.0	<1.0	<1.0	<1.0
trans-1,3-Dichloropropene	5	<1.0	<1.0	<1.0	<1.0
Trichloroethylene	5	45.1	55.6	44.5	45.0
Trichlorotrifluoroethane (Freon 113)	5	1.4 J	1.5 J	1.2 J	1.5 J
Vinyl Chloride	2	<1.0	<1.0	<1.0	<1.0
Xylene-o	5	<1.0	<1.0	<1.0	<1.0
Xylene-m,p	5	<1.0	<1.0	<1.0	<1.0
Total VOCs⁽⁴⁾		67	84	67	68
1,4-Dioxane⁽²⁾	NS	7.06	7.03	7.44	6.86

Notes and abbreviations on last page.

Table 4
Concentrations of Constituents in Remedial Wells and
Treatment System Effluents, 2017, Operable Unit 2,
Northrop Grumman Systems Corporation,
Bethpage, New York

Constituents ⁽¹⁾ (units in µg/L)	Location ID: Sample ID: Sample Date:	WELL 19 WELL 19 2/14/2017	WELL 19 WELL 19 6/27/2017	WELL 19 WELL 19 9/12/2017 ⁽⁵⁾	WELL 19 WELL 19 12/13/2017
<u>Volatile Organic Compounds (VOCs)⁽²⁾</u>					
	NYSDEC SCGs ⁽³⁾				
1,1,1-Trichloroethane	5	0.33 J	0.30 J	0.28 J	0.27 J
1,1,1,2-Tetrachloroethane	5	<1.0	<1.0	<1.0	<1.0
1,1,1,2-Trichloroethane	5	<1.0	<1.0	<1.0	<1.0
1,1-Dichloroethane	5	0.71 J	0.76 J	0.66 J	0.68 J
1,1-Dichloroethene	5	1.5	1.9	1.4	1.5
1,2-Dichloroethane	5	<1.0	0.34 J	0.30 J	0.25 J
1,2-Dichloropropane	5	<1.0	<1.0	<1.0	<1.0
2-Butanone (MEK)	50	<10	<10	<10	<10
2-Hexanone (MBK)	50	<5.0	<5.0	<5.0	<5.0
4-methyl-2-pentanone (MIK)	50	<5.0	<5.0	<5.0	<5.0
Acetone	50	<10	<10	<10	<10
Benzene	1	<0.50	<0.50	<0.50	<0.50
Bromodichloromethane	50	<1.0	<1.0	<1.0	<1.0
Bromoform	50	<1.0	<1.0	<1.0	<1.0
Bromomethane	5	<2.0	<2.0	<2.0	<2.0
Carbon Disulfide	50	<2.0	<2.0	<2.0	<2.0
Carbon Tetrachloride	5	<1.0	<1.0	<1.0	<1.0
Chlorobenzene	5	<1.0	<1.0	<1.0	<1.0
Chloroethane	5	<1.0	<1.0	<1.0	<1.0
Chloroform	7	0.37 J	0.48 J	0.40 J	0.36 J
Chloromethane	5	<1.0	<1.0	<1.0	<1.0
cis-1,2-Dichloroethene	5	16.1	19.4	16.5	15.1
cis-1,3-Dichloropropene	5	<1.0	<1.0	<1.0	<1.0
Dibromochloromethane	5	<1.0	<1.0	<1.0	<1.0
Ethylbenzene	5	<1.0	<1.0	<1.0	<1.0
Methylene Chloride	5	<2.0	<2.0	<2.0	<2.0
Styrene	5	<1.0	<1.0	<1.0	<1.0
Tetrachloroethene	5	6.6	6.0	6.7	6.4
Toluene	5	<1.0	<1.0	<1.0	<1.0
trans-1,2-Dichloroethene	5	<1.0	<1.0	<1.0	<1.0
trans-1,3-Dichloropropene	5	<1.0	<1.0	<1.0	<1.0
Trichloroethylene	5	139	132	118	118
Trichlorotrifluoroethane (Freon 113)	5	<5.0	<5.0	<5.0	<5.0
Vinyl Chloride	2	<1.0	<1.0	<1.0	<1.0
Xylene-o	5	<1.0	<1.0	<1.0	<1.0
Xylene-m,p	5	<1.0	<1.0	<1.0	<1.0
Total VOCs⁽⁴⁾		160	160	140	140
1,4-Dioxane⁽²⁾	NS	6.34	5.59	5.53	6.3

Notes and abbreviations on last page.

Table 4
Concentrations of Constituents in Remedial Wells and
Treatment System Effluents, 2017, Operable Unit 2,
Northrop Grumman Systems Corporation,
Bethpage, New York

Constituents ⁽¹⁾ (units in µg/L)	Location ID: Sample ID: Sample Date:	102 EFFLUENT 102 EFFLUENT 2/14/2017	102 EFFLUENT 102 EFFLUENT 6/27/2017	102 EFFLUENT 102 EFFLUENT 9/12/2017 ⁽⁵⁾	102 EFFLUENT T102 EFFLUENT 12/21/2017
<u>Volatile Organic Compounds (VOCs)⁽²⁾</u>					
	NYSDEC SCGs ⁽³⁾				
1,1,1-Trichloroethane	5	<1.0	<1.0	<1.0	<1.0
1,1,2,2-Tetrachloroethane	5	<1.0	<1.0	<1.0	<1.0
1,1,2-Trichloroethane	5	<1.0	<1.0	<1.0	<1.0
1,1-Dichloroethane	5	<1.0	<1.0	<1.0	<1.0
1,1-Dichloroethene	5	<1.0	<1.0	<1.0	<1.0
1,2-Dichloroethane	5	<1.0	<1.0	<1.0	<1.0
1,2-Dichloropropane	5	<1.0	<1.0	<1.0	<1.0
2-Butanone (MEK)	50	<10	<10	<10	<10
2-Hexanone (MBK)	50	<5.0	<5.0	<5.0	<5.0
4-methyl-2-pentanone (MIK)	50	<5.0	<5.0	<5.0	<5.0
Acetone	50	<10	<10	<10	<10
Benzene	1	<0.50	<0.50	<0.50	<0.50
Bromodichloromethane	50	<1.0	<1.0	<1.0	<1.0
Bromoform	50	<1.0	<1.0	<1.0	<1.0
Bromomethane	5	<2.0	<2.0	<2.0	<2.0
Carbon Disulfide	50	<2.0	<2.0	<2.0	<2.0
Carbon Tetrachloride	5	<1.0	<1.0	<1.0	<1.0
Chlorobenzene	5	<1.0	<1.0	<1.0	<1.0
Chloroethane	5	<1.0	<1.0	<1.0	<1.0
Chloroform	7	<1.0	<1.0	<1.0	<1.0
Chloromethane	5	<1.0	<1.0	<1.0	<1.0
cis-1,2-Dichloroethene	5	<1.0	<1.0	<1.0	<1.0
cis-1,3-Dichloropropene	5	<1.0	<1.0	<1.0	<1.0
Dibromochloromethane	5	<1.0	<1.0	<1.0	<1.0
Ethylbenzene	5	<1.0	<1.0	<1.0	<1.0
Methylene Chloride	5	<2.0	<2.0	<2.0	<2.0
Styrene	5	<1.0	<1.0	<1.0	<1.0
Tetrachloroethene	5	<1.0	<1.0	<1.0	<1.0
Toluene	5	<1.0	<1.0	<1.0	<1.0
trans-1,2-Dichloroethene	5	<1.0	<1.0	<1.0	<1.0
trans-1,3-Dichloropropene	5	<1.0	<1.0	<1.0	<1.0
Trichloroethylene	5	<1.0	<1.0	<1.0	<1.0
Trichlorotrifluoroethane (Freon 113)	5	<5.0	<5.0	<5.0	<5.0
Vinyl Chloride	2	<1.0	<1.0	<1.0	<1.0
Xylene-o	5	<1.0	<1.0	<1.0	<1.0
Xylene-m,p	5	<1.0	<1.0	<1.0	<1.0
Total VOCs⁽⁴⁾		0.0	0.0	0.0	0.0
1,4-Dioxane⁽²⁾	NS	6.13 J	6.82	7.02	6.49 J

Notes and abbreviations on last page.

Table 4
Concentrations of Constituents in Remedial Wells and
Treatment System Effluents, 2017, Operable Unit 2,
Northrop Grumman Systems Corporation,
Bethpage, New York

Notes and Abbreviations:

- (1) Results for the program are validated at 20% frequency, per protocols specified in OU2 Groundwater Monitoring Plan (Arcadis 2016c).
- (2) VOC samples analyzed using USEPA Method 8260C. 1,4-dioxane samples analyzed using using USEPA Method 52
- (3) SCG values based on documents referenced in the Groundwater Feasibility Study Report (ARCADIS Geraghty & Miller, Inc. 2000) that are based on the NYSDEC TOGs (NYSDEC 1998); most stringent values are listed.
- (4) Total VOC results rounded to two significant figures.
- (5) 1,4 Dioxane sample collected on October 12, 2017.

Compound detected in exceedance of NYSDEC SCG Criteria.

1.2 Bold value indicates a detection.

< 5.0 Compound is not detected above its laboratory quantification limit.

J Constituent value is estimated.

µg/L micrograms per liter

NS None Specified

NYSDEC New York State Department of Conservation

OU2 Operable Unit 2

REP blind replicate sample

SCG Standards, Criteria and Guidance value

TOGs Technical and Operational Guidance Series

USEPA United States Environmental Protection Agency

VOC volatile organic compound

Table 5A
Summary of Influent and Mid-Effluent Air Concentrations and
Effluent Air Emissions^(1,3)2017, Tower 96 Treatment System
Northrop Grumman Systems Corporation
Operable Unit 2, Bethpage, New York

Location ID: Sample ID:	96 INFLUENT T96 INFLUENT (AA)	96 INFLUENT T96 INFLUENT (AA)	96 INFLUENT T96 INFLUENT (AA)
Constituents (Units in µg/m ³)	2/14/2017	3/21/2017	4/14/2017
<u>Volatile Organic Compounds (VOCs)⁽¹⁾</u>			
1,1,1-Trichloroethane	20	15	<71
1,1,1,2-Tetrachloroethane	<0.69	<0.69	<89
1,1,2-Trichloroethane	2.3	2.1	<71
1,1-Dichloroethane	40	35	<110
1,1-Dichloroethene	132	97.9	105 J
1,2-Dichloroethane	2.2	2.5	<110
1,2-Dichloropropane	78.1	64.7	75.8 J
Benzene	1.4	1.6	<86
Bromodichloromethane	<0.67	<0.67	<87
Bromoform	<0.41	<0.41	<55
Bromomethane	<0.78	<0.78	<100
Carbon Disulfide	<0.62	0.21 J	<84
Carbon Tetrachloride	4.1	3.3	<33
Chlorobenzene	1.9	1.4	<120
Chloroethane	3.4	2.6	<71
Chloroform	9.8	8.3	<130
Chloromethane	0.91	1.1	<56
cis-1,2-Dichloroethene ⁽³⁾	--	--	--
cis-1,3-Dichloropropene	<0.91	<0.91	<120
Dibromochloromethane	<0.85	<0.85	<110
Ethylbenzene	<0.87	<0.87	<120
Methylene Chloride	1.3	1.4	<94
Styrene	<0.85	<0.85	<110
Tetrachloroethene	1110	1650	936
Toluene	0.72 J	1.3	<100
trans-1,2-Dichloroethene ⁽³⁾	--	--	--
trans-1,3-Dichloropropene	<0.91	<0.91	<120
Trichloroethylene	24300	23800	18200
Trichlorotrifluoroethane (Freon 113)	134	109	117
Vinyl Chloride	60.6	48.3	49.1
Xylene-o	<0.87	<0.87	<120
Xylene-m,p	<0.87	1.1	<120
Total VOCs⁽²⁾	25,903	25,847	19,483

Notes and abbreviations on last page.

Table 5A
Summary of Influent and Mid-Effluent Air Concentrations and
Effluent Air Emissions^(1,3)2017, Tower 96 Treatment System
Northrop Grumman Systems Corporation
Operable Unit 2, Bethpage, New York

Location ID: Sample ID:	96 INFLUENT T96 INFLUENT (AA)	96 INFLUENT T96 INFLUENT (AA)	96 INFLUENT T96 INFLUENT (AA)	96 INFLUENT T96 INFLUENT (AA)
Constituents (Units in µg/m ³)	5/11/2017	6/30/2017	9/19/2017	12/13/2017
Volatile Organic Compounds (VOCs)⁽¹⁾				
1,1,1-Trichloroethane	<76	<76	<22	<22
1,1,1,2-Tetrachloroethane	<96	<96	<27	<27
1,1,2-Trichloroethane	<76	<76	<22	<22
1,1-Dichloroethane	<110	<110	40.9	36
1,1-Dichloroethene	120	86.4 J	99.5	107
1,2-Dichloroethane	<110	<110	<32	<32
1,2-Dichloropropane	87.8 J	73.0 J	88.7	81.8
Benzene	<89	<86	<26	<26
Bromodichloromethane	<94	<94	<27	<27
Bromoform	<57	<56	<17	<17
Bromomethane	<110	<100	<31	<31
Carbon Disulfide	<87	<84	<25	<25
Carbon Tetrachloride	<35	<34	<10	<10
Chlorobenzene	<130	<120	<37	<37
Chloroethane	<74	<71	<21	<21
Chloroform	<140	<130	<39	<39
Chloromethane	<58	<56	<17	<17
cis-1,2-Dichloroethene ⁽²⁾	--	--	--	158
cis-1,3-Dichloropropene	<130	<120	<36	<36
Dibromochloromethane	<120	<120	<34	<34
Ethylbenzene	<120	<120	<35	<35
Methylene Chloride	<97	<94	<28	<28
Styrene	<120	<110	<34	<34
Tetrachloroethene	1410	909	667	929
Toluene	<110	31 J	<30	<30
trans-1,2-Dichloroethene ⁽³⁾	--	--	--	<32
trans-1,3-Dichloropropene	<130	<120	<36	<36
Trichloroethylene	21600	19700	12100	18600
Trichlorotrifluoroethane (Freon 113)	130	124	121	121
Vinyl Chloride	50.6	50.4	49.6	42.9
Xylene-o	<120	<120	<35	<35
Xylene-m,p	<120	<120	<35	<35
Total VOCs⁽²⁾	23,398	20,974	13,167	20,076

Notes and abbreviations on last page.

Table 5A
Summary of Influent and Mid-Effluent Air Concentrations and
Effluent Air Emissions^(1,3)2017, Tower 96 Treatment System
Northrop Grumman Systems Corporation
Operable Unit 2, Bethpage, New York

Location ID:	96 MID-EFFLUENT	96 MID-EFFLUENT	96 MID-EFFLUENT	96 MID-EFFLUENT
Sample ID:	T96 MIDTRAIN (AA)	T96 MIDTRAIN (AA)	T96 MIDTRAIN (AA)	T96 MIDTRAIN (AA)
Constituents (Units in $\mu\text{g}/\text{m}^3$)	5/11/2017	6/27/2017	9/19/2017	12/13/2017
Volatile Organic Compounds (VOCs)⁽¹⁾				
1,1,1-Trichloroethane	<22	<11	<16	<11
1,1,1,2-Tetrachloroethane	<27	<14	<21	<14
1,1,2-Trichloroethane	<22	<11	<16	<11
1,1-Dichloroethane	51.4	30	33	34
1,1-Dichloroethene	174	103	88.8	109
1,2-Dichloroethane	<32	<16	<24	<16
1,2-Dichloropropane	37	18 J	31	29
Benzene	<26	<13	<19	<13
Bromodichloromethane	<27	<13	<20	<13
Bromoform	<17	<8.3	<12	<8.3
Bromomethane	<31	<16	<23	<16
Carbon Disulfide	<25	<12	<18	<12
Carbon Tetrachloride	<10	<5.0	<7.5	<5.0
Chlorobenzene	<37	<18	<27	<18
Chloroethane	<21	<11	<16	<11
Chloroform	<39	<20	<29	9.8 J
Chloromethane	<17	<8.3	<12	<8.3
cis-1,2-Dichloroethene ⁽²⁾	--	--	--	145
cis-1,3-Dichloropropene	<36	<18	<27	<18
Dibromochloromethane	<34	<17	<26	<17
Ethylbenzene	<35	<17	<26	<17
Methylene Chloride	<28	<14	<20	<14
Styrene	<34	<17	<25	<17
Tetrachloroethene	155	63	138	205
Toluene	<30	<15	<22	<15
trans-1,2-Dichloroethene ⁽³⁾	--	--	--	<16
trans-1,3-Dichloropropene	<36	<18	<27	<18
Trichloroethylene	4800 D	4030	6610	6610
Trichlorotrifluoroethane (Freon 113)	139	71	85.1	93.5
Vinyl Chloride	85.4	51.6	50.4	46.3
Xylene-o	<35	<17	<26	<17
Xylene-m,p	<35	<17	<26	<17
Total VOCs⁽²⁾	5,442	4,367	7,036	7,282

Notes and abbreviations on last page.

Table 5A
Summary of Influent and Mid-Effluent Air Concentrations and
Effluent Air Emissions^(1,3)2017, Tower 96 Treatment System
Northrop Grumman Systems Corporation
Operable Unit 2, Bethpage, New York

Location ID: Sample ID:	96 SUP MIDTRAIN T96 SUP MIDTRAIN (AA)	96 SUP MIDTRAIN T96 SUP MIDTRAIN (AA)	96 SUP MIDTRAIN T96 SUP MIDTRAIN (AA)	96 SUP MIDTRAIN T96 SUP MIDTRAIN (AA)
Constituents (Units in µg/m ³)	2/14/2017	3/21/2017	9/19/2017	12/13/2017
Volatile Organic Compounds (VOCs)⁽¹⁾				
1,1,1-Trichloroethane	<0.55	5.5	<11	<2.2
1,1,2,2-Tetrachloroethane	<0.69	<0.69	<14	<2.7
1,1,2-Trichloroethane	<0.55	<0.55	<11	<2.2
1,1-Dichloroethane	<0.81	59.1	28	11
1,1-Dichloroethene	1.4	348	78.1	51.9
1,2-Dichloroethane	<0.81	1.5	<16	<3.2
1,2-Dichloropropane	<0.92	0.74 J	27	<3.7
Benzene	<0.64	0.35 J	<13	<2.6
Bromodichloromethane	<0.67	<0.67	<13	<2.7
Bromoform	<0.41	<0.41	<8.3	<1.7
Bromomethane	<0.78	<0.78	<16	<3.1
Carbon Disulfide	<0.62	<0.62	<12	<2.5
Carbon Tetrachloride	<0.25	<0.25	<5.0	<1.0
Chlorobenzene	<0.92	<0.92	<18	<3.7
Chloroethane	5.0	2.9	<11	3.4
Chloroform	<0.98	9.3	<20	2.1 J
Chloromethane	1.2	0.93	<8.3	1.4 J
cis-1,2-Dichloroethene ⁽²⁾	--	--	--	39
cis-1,3-Dichloropropene	<0.91	<0.91	<18	<3.6
Dibromochloromethane	<0.85	<0.85	<17	<3.4
Ethylbenzene	<0.87	0.87	<17	<3.5
Methylene Chloride	3.2	1.1	<14	<2.8
Styrene	<0.85	<0.85	<17	<3.4
Tetrachloroethene	1.2	0.88	8.8	<1.1
Toluene	<0.75	4.9	17	80.6
trans-1,2-Dichloroethene ⁽³⁾	--	--	--	<3.2
trans-1,3-Dichloropropene	<0.91	<0.91	<18	<3.6
Trichloroethylene	142	2580	3670	95.1
Trichlorotrifluoroethane (Freon 113)	2.3	79.7	75	7.3
Vinyl Chloride	86.1	50.6	48.1	41.9
Xylene-o	<0.87	9.6	<17	<3.5
Xylene-m,p	<0.87	16	<17	<3.5
Total VOCs⁽²⁾	242	3,172	3,952	334

Notes and abbreviations on last page.

Table 5A
Summary of Influent and Mid-Effluent Air Concentrations and
Effluent Air Emissions^(1,3)2017, Tower 96 Treatment System
Northrop Grumman Systems Corporation
Operable Unit 2, Bethpage, New York

Location ID: Sample ID:	96 EFFLUENT T96 EFFLUENT (AA)	96 EFFLUENT T96 EFFLUENT (AA)	96 EFFLUENT T96 EFFLUENT (AA)	96 EFFLUENT T96 EFFLUENT (AA)
Constituents (Units in µg/m ³)	2/14/2017	3/21/2017	4/14/2017	5/11/2017 ⁽⁴⁾
Volatile Organic Compounds (VOCs)⁽¹⁾				
1,1,1-Trichloroethane	<0.55	5.5	<71	R
1,1,2,2-Tetrachloroethane	<0.69	<0.69	<89	R
1,1,2-Trichloroethane	<0.55	<0.55	<71	R
1,1-Dichloroethane	<0.81	57.5	73.3 J	R
1,1-Dichloroethene	1.1	158	133	R
1,2-Dichloroethane	<0.81	1.3	<100	R
1,2-Dichloropropane	<0.92	1.5	<120	R
Benzene	<0.64	<0.64	<80	R
Bromodichloromethane	<0.67	<0.67	<87	R
Bromoform	<0.41	<0.41	<52	R
Bromomethane	<0.78	<0.78	<97	R
Carbon Disulfide	<0.62	<0.62	<78	R
Carbon Tetrachloride	<0.25	<0.25	<31	R
Chlorobenzene	<0.92	<0.92	<120	R
Chloroethane	5.5	3.7	<66	R
Chloroform	<0.98	9.8	<120	R
Chloromethane	3.3	9.3	<52	R
cis-1,2-Dichloroethene ⁽²⁾	--	--	--	--
cis-1,3-Dichloropropene	<0.91	<0.91	<110	R
Dibromochloromethane	<0.85	<0.85	<110	R
Ethylbenzene	<0.87	<0.87	<110	R
Methylene Chloride	2.3	1.3	<87	R
Styrene	<0.85	<0.85	<110	R
Tetrachloroethene	2.9	12	<34	R
Toluene	<0.75	<0.75	<94	R
trans-1,2-Dichloroethene ⁽³⁾	--	--	--	--
trans-1,3-Dichloropropene	<0.91	<0.91	<110	R
Trichloroethylene	42	1280	16600	R
Trichlorotrifluoroethane (Freon 113)	0.77	82.8	284	R
Vinyl Chloride	16	12	49.6	R
Xylene-o	<0.87	<0.87	<110	R
Xylene-m,p	<0.87	<0.87	61.2 J	R
Total VOCs⁽²⁾	74	1,635	17,201	R

Notes and abbreviations on last page.

Table 5A
Summary of Influent and Mid-Effluent Air Concentrations and
Effluent Air Emissions^(1,3)2017, Tower 96 Treatment System
Northrop Grumman Systems Corporation
Operable Unit 2, Bethpage, New York

Location ID: Sample ID:	96 EFFLUENT T96 EFFLUENT (AA)	96 EFFLUENT T96 EFFLUENT (AA)	96 EFFLUENT T96 EFFLUENT (AA)	96 EFFLUENT T96 EFFLUENT (AA)
Constituents (Units in µg/m ³)	6/27/2017	7/18/2017	9/19/2017	12/13/2017
Volatile Organic Compounds (VOCs)⁽¹⁾				
1,1,1-Trichloroethane	3.2	<11	<16	<2.2
1,1,2,2-Tetrachloroethane	<0.69	<14	<21	<2.7
1,1,2-Trichloroethane	<0.55	<11	<16	<2.2
1,1-Dichloroethane	36	35	38	<3.2
1,1-Dichloroethene	111	117	99.1	2.3
1,2-Dichloroethane	1.5	<16	<24	<3.2
1,2-Dichloropropane	<0.92	<18	26 J	<3.7
Benzene	16	38.3	<19	<2.6
Bromodichloromethane	<0.67	<13	<20	<2.7
Bromoform	<0.41	<8.3	<12	<1.7
Bromomethane	<0.78	<16	<23	<3.1
Carbon Disulfide	<0.62	<12	<18	<2.5
Carbon Tetrachloride	0.75	<5.0	<7.5	<1.0
Chlorobenzene	<0.92	<18	<27	<3.7
Chloroethane	4.0	<11	<16	2.9
Chloroform	10	10 J	<29	<3.9
Chloromethane	3.1	<8.3	<12	1.7
cis-1,2-Dichloroethene ⁽²⁾	--	--	--	<0.63
cis-1,3-Dichloropropene	<0.91	<18	<27	<3.6
Dibromochloromethane	<0.85	<17	<26	<3.4
Ethylbenzene	<0.87	<17	<26	<3.5
Methylene Chloride	1.1	<14	<20	<2.8
Styrene	<0.85	<17	<25	<3.4
Tetrachloroethene	2.2	<5.4	<8.1	<1.1
Toluene	39.2	46.7	38.4	259
trans-1,2-Dichloroethene ⁽³⁾	--	--	--	<3.2
trans-1,3-Dichloropropene	<0.91	<18	<27	<3.6
Trichloroethylene	591	3360	6130	10
Trichlorotrifluoroethane (Freon 113)	87.4	111	102	<3.1
Vinyl Chloride	55.5	52.1	67.7	36.3
Xylene-o	<0.87	<17	<26	<3.5
Xylene-m,p	<0.87	<17	<26	<3.5
Total VOCs⁽²⁾	962	3,770	6,501	312

Notes and abbreviations on last page.

Table 5A
Summary of Influent and Mid-Effluent Air Concentrations and
Effluent Air Emissions^(1,3) 2017, Tower 96 Treatment System
Northrop Grumman Systems Corporation
Operable Unit 2, Bethpage, New York

Notes and Abbreviations:

- (1) Vapor samples collected by Arcadis on the dates shown and submitted to a NYSDOH ELAP certified laboratory for VOC analyses per Modified USEPA Method TO-15.
- (2) Total VOCs represents the sum of individual concentrations of compounds detected rounded to the nearest whole
- (3) Analytes cis- 1,2-dichloroethene, and trans- 1,2-dichloroethene were added to the sampling analyte list in October 2017.
- (4) The laboratory supplied flow controller/pressure gauge attached to the summa canister associated with sample location T96 EFFLUENT(AA) malfunctioned during the sampling event. The flow controller/pressure gauge used previously to collect sample location T96 INFLUENT(AA) was used to collect sample location T96 EFFLUENT(AA). Due to the fact that a designated flow controller/pressure gauge was not used to collect sample location T96 Effluent(AA); the sample results are considered unusable/rejected.

- Not Analyzed
- 26** bold value indicates a detection
- D Concentration is based on a diluted sample analysis.
- J Compound detected below its reporting limit; value is estimated.
- R Sample result rejected
- µg/m³ micrograms per cubic meter
- ELAP Environmental Laboratory Approval Program
- NYSDOH New York State Department of Health
- USEPA United States Environmental Protection Agency
- VOC Volatile Organic Compound

Table 5B

**Summary of Influent Air Concentrations and Effluent Air Emissions ⁽¹⁾ 2017,
Tower 102 Treatment System,
Northrop Grumman Systems Corporation,
Operable Unit 2, Bethpage, New York**



Location ID: Sample ID:	102 INFLUENT T102 INFLUENT (AA) 2/14/2017	102 INFLUENT T102 INFLUENT (AA) 6/30/2017	102 INFLUENT T102 INFLUENT (AA) 10/17/2017	102 INFLUENT T102 INFLUENT (AA) 12/21/2017
Constituents (Units in µg/m³)				
<u>Volatile Organic Compounds (VOCs)⁽¹⁾</u>				
1,1,1-Trichloroethane	41	39	23	16
1,1,2,2-Tetrachloroethane	<0.69	<27	<0.69	<14
1,1,2-Trichloroethane	2.1	<22	1.5	<11
1,1-Dichloroethane	88.2	78.9	53.4	38
1,1-Dichloroethene	222	164	115	74.9
1,2-Dichloroethane	6.1	<32	4.0	<16
1,2-Dichloropropane	6.0	<37	5.5	<18
Benzene	1.3	23 J	0.61 J	<13
Bromodichloromethane	<0.67	<27	<0.67	<13
Bromoform	<0.41	<17	<0.41	<8.3
Bromomethane	<0.78	<31	<0.78	<16
Carbon Disulfide	<0.62	<25	<0.62	<12
Carbon Tetrachloride	6.9	<10	4.8	<5.0
Chlorobenzene	<0.92	<37	<0.92	<18
Chloroethane	<0.53	<21	<0.53	<11
Chloroform	28	26 J	18	13
Chloromethane	0.95	<17	0.78	<8.3
cis-1,2 Dichloroethene ⁽³⁾	--	--	396	370
cis-1,3-Dichloropropene	<0.91	<36	<0.91	<18
Dibromochloromethane	<0.85	<34	<0.85	<17
Ethylbenzene	0.74 J	<35	<0.87	<17
Methylene Chloride	1.1	<28	1.0	<14
Styrene	<0.85	<34	<0.85	<17
Tetrachloroethene	698	584	395	207
Toluene	2.7	<30	<0.75	<15
trans-1,2-Dichloroethene ⁽³⁾	--	--	3.7	<16
trans-1,3-Dichloropropene	<0.91	<36	<0.91	<18
Trichloroethylene	7150	5480	3990	2340
Trichlorotrifluoroethane (Freon 113)	165	168	113	74
Vinyl Chloride	0.43	<4.1	0.28	<2.0
Xylene-o	6.1	<35	<0.87	<17
Xylene-m,p	10	<35	<0.87	<17
Total VOCs ⁽²⁾	8,437	6,563	5,126	3,133

Notes and abbreviations on last page.

Table 5B

**Summary of Influent Air Concentrations and Effluent Air Emissions ⁽¹⁾ 2017,
Tower 102 Treatment System,
Northrop Grumman Systems Corporation,
Operable Unit 2, Bethpage, New York**

Location ID:	102 EFFLUENT	102 EFFLUENT	102 EFFLUENT	102 EFFLUENT
Sample ID:	T102 EFFLUENT (AA)	T102 EFFLUENT (AA)	T102 EFFLUENT (AA)	T102 EFFLUENT (AA)
Constituents (Units in µg/m ³)	2/14/2017	6/30/2017	10/17/2017	12/21/2017
<u>Volatile Organic Compounds (VOCs)⁽¹⁾</u>				
1,1,1-Trichloroethane	<0.55	<5.5	0.60	0.60
1,1,2,2-Tetrachloroethane	<0.69	<6.9	<0.69	<0.69
1,1,2-Trichloroethane	<0.55	<5.5	<0.55	<0.55
1,1-Dichloroethane	3.6	<8.1	19	21
1,1-Dichloroethene	19	48.4	103	126
1,2-Dichloroethane	<0.81	9.7	<0.81	<0.81
1,2-Dichloropropane	<0.92	<9.2	<0.92	<0.92
Benzene	3.8	83.1	<0.64	<0.64
Bromodichloromethane	<0.67	<6.7	<0.67	<0.67
Bromoform	<0.41	<4.1	<0.41	<0.41
Bromomethane	0.43 J	<7.8	<0.78	<0.78
Carbon Disulfide	16	<6.2	<0.62	<0.62
Carbon Tetrachloride	<0.25	<2.5	<0.25	<0.25
Chlorobenzene	<0.92	<9.2	<0.92	<0.92
Chloroethane	<0.53	<5.3	<0.53	<0.53
Chloroform	0.73 J	<9.8	3.2	2.9
Chloromethane	1.0	<4.1	0.81	1.2
cis-1,2 Dichloroethene ⁽³⁾	--	--	39	35
cis-1,3-Dichloropropene	<0.91	<9.1	<0.91	<0.91
Dibromochloromethane	<0.85	<8.5	<0.85	<0.85
Ethylbenzene	2.2	11	<0.87	<0.87
Methylene Chloride	1.3	<6.9	9.4	0.90
Styrene	<0.85	<8.5	<0.85	<0.85
Tetrachloroethene	3.9	6.2	4.3	<0.27
Toluene	0.72 J	6.8 J	<0.75	<0.75
trans-1,2-Dichloroethene ⁽³⁾	--	--	0.59 J	0.75 J
trans-1,3-Dichloropropene	<0.91	<9.1	<0.91	<0.91
Trichloroethylene	20	15	40	5.3
Trichlorotrifluoroethane (Freon 113)	4.2	7.4 J	22	28
Vinyl Chloride	0.46	<1.0	0.28	<0.10
Xylene-o	<0.87	<8.7	<0.87	<0.87
Xylene-m,p	4.0	<8.7	<0.87	<0.87
Total VOCs ⁽²⁾	81	188	242	222

Notes and abbreviations on last page.

Table 5B

**Summary of Influent Air Concentrations and Effluent Air Emissions⁽¹⁾ 2017,
Tower 102 Treatment System,
Northrop Grumman Systems Corporation,
Operable Unit 2, Bethpage, New York**

Notes and Abbreviations:

- (1) Vapor samples collected by Arcadis on the dates shown and submitted to a NYSDOH ELAP certified laboratory for VOC analyses per Modified USEPA Method TO-15.
- (2) Total VOCs represents the sum of individual concentrations of compounds detected rounded to the nearest whole number.
- (3) Analytes cis- 1,2-dichloroethene, and trans- 1,2-dichloroethene were added to the sampling analyte list in October 2017.
- Not Analyzed
- 26** bold value indicates a detection
- J Compound detected below its reporting limit; value is estimated.
- D Concentration is based on a diluted sample analysis.
- µg/m³ micrograms per cubic meter
- ELAP Environmental Laboratory Approval Program
- NYSDOH New York State Department of Health
- USEPA United States Environmental Protection Agency
- VOC volatile organic compound

Table 5C
Summary of TCE Mass Removal, Tower 96 Treatment System,
Annual 2017, Northrop Grumman Systems Corporation,
Operable Unit 2, Bethpage, New York^(1,2,3)

Date	TCE Concentration ($\mu\text{g}/\text{m}^3$)				TCE Mass Emission ⁽⁶⁾	Percent of Allowable TCE Emissions ⁽⁷⁾	
	T96 INFLUENT	T96 MIDTRAIN	T96 SUP MIDTRAIN	T96 EFFLUENT	(lbs)	12 Month Rolling Average	
3/14/2016	24,892	4,311	NS	50	0.6	3.4%	
5/12/2016	25,539	7,455	NS	49	0.6	3.3%	
8/17/2016	24,787	4,232	NS	34	0.5	2.3%	
12/22/2016	29,031	4,018	NS	161	2.3	2.2%	
PILOT STUDY	2/14/2017 ⁽²⁾	24,300	NS	142	42	0.8	2.2%
	3/21/2017	23,800	NS	2,580	1,280	20	6.1%
	4/14/2017 ^(3,4)	18,200	NS	NS	16,600	184	43.5%
	5/11/2017 ⁽⁸⁾	21,600	4,800	NS	4,800	55	55.2%
	6/27/2017 ^(5,9)	19,700	4,030	NS	591	13	55.1%
	7/18/2017	NS	NS	NS	3,360	30	63.4%
	8/18/2017 ⁽¹⁰⁾	NS	NS	NS	4,745	66	76.7%
	9/19/2017	12,100	6,610	3,670	6,130	87	92.4%
	12/13/2017	18,600	6,610	95	10	0.1	91.4%

Notes and Abbreviations:

- (1) Vapor samples collected by Arcadis on the dates shown and submitted to a NYSDOH ELAP certified laboratory for VOC analyses per Modified USEPA Method TO-15.
- (2) System transitioned from a regenerative VPGAC to once-through VPGAC (Supplemental Bed 1) system with PPZ polishing bed (Supplemental Bed 2) on 1/30/2017. Northrop Grumman performed pilot testing on this operational modification as discussed with NYSDEC on January 26, 2017.
- (3) PPZ media was removed from the Supplemental Bed 2 on 3/23/2017 by OXY and was left empty.
- (4) A system operation pilot study was initiated on 1/30/2017 and ended on 5/3/2017 (ref. email from Steven Scharf (NYSDEC) to Roger Smith (OXY) on January 26, 2017 2:17 PM "Air Treatment on NGC OU 2 ONCT System").
- (5) A carbon change out was performed in Supplemental Bed 1 and new carbon was placed in the previously empty Supplemental Bed 2 on May 18, 2017.
- (6) TCE Mass Emission calculated based on the exhaust air flow rate on the day of sampling and the period of time since the preceding day of sampling.

$$\text{TCE (lb)} = \text{TCE Concentration } [\mu\text{g}/\text{m}^3] \times \text{Days} \times \text{Flow Rate } [\text{ft}^3/\text{min}] \times (1 \text{ m}^3/35 \text{ ft}^3) \times (60 \text{ min}/\text{hr}) \times (24 \text{ hr}/\text{day}) \times (0.000001 \text{ g}/1 \text{ ug}) \times (0.0022 \text{ lb}/\text{g})$$
- (7) Percent of allowable TCE emissions to date is a time-weighted annual rolling average based on the 500 lb/year emission limit specified in the CRR-NY 212-2.2 Table 2. High Toxicity Air Contaminant List, revised April 1, 2017.
- (8) For calculation purposes, the T96 MIDTRAIN concentration was used for the T96 Effluent result for May 11, 2017 as the T96 Effluent sample results were validated and rejected based on the use of non-dedicated sample collection fittings.
- (9) T96 Influent sample collected on 6/30/2017.
- (10) Sampling not conducted in August, the average of July and September effluent data and actual average air flow rate for the time period were used for estimated calculations for August 18, 2017.

<i>italics</i>	dates of pilot test using once through carbon treatment operation.
$\mu\text{g}/\text{m}^3$	micrograms per cubic meter
lbs	pounds
CRR-NY	Codes, Rules and Regulations of the State of New York
ELAP	Environmental Laboratory Approval Program
NA	not applicable
NS	not sampled
NYSDOH	New York State Department of Health
PPZ	potassium permanganate coated zeolite
SUP	supplemental
TCE	trichloroethylene
USEPA	United States Environmental Protection Agency
VOC	volatile organic compound
VPGAC	vapor phase granular activated carbon

Table 5D
Summary of TCE Mass Removal, Tower 102 Treatment System,
Annual 2017, Northrop Grumman Systems Corporation,
Operable Unit 2, Bethpage, New York^(1,2,3)

Date	TCE Concentration ($\mu\text{g}/\text{m}^3$)		TCE Mass Emission ⁽²⁾	Percentage of Allowable TCE Emissions ⁽³⁾
	T102 INFLUENT	T102 EFFLUENT	(lbs)	12 Month Rolling Average
3/14/2016	5,700	31	2	NA
5/12/2016	2,340	83	3	NA
8/17/2016	8,550	13	0.9	NA
12/15/2016	5,800	33	2.8	NA
2/14/2017	7,150	20	0.9	1.7%
6/30/2017	5,480	15	1.5	1.1%
10/17/2017	3,990	40	3.0	1.3%
12/21/2017	2,340	5	0.2	1.1%

Notes and Abbreviations:

- (1) Vapor samples collected by Arcadis on the dates shown and submitted to a NYSDOH ELAP certified laboratory for VOC analyses per Modified USEPA Method TO-15.
- (2) TCE Mass Emission calculated based on the exhaust air flow rate on the day of sampling and the period of time since the preceding sampling day.

$$\text{TCE (lb)} = \text{TCE Concentration } [\mu\text{g}/\text{m}^3] \times \text{Days} \times \text{Flow Rate } [\text{ft}^3/\text{min}] \times (1 \text{ m}^3/35 \text{ ft}^3) \times (60 \text{ min}/\text{hr}) \times (24 \text{ hr}/\text{day}) \times (0.000001 \text{ g}/1 \text{ ug}) \times (0.0022 \text{ lb}/\text{g})$$
- (3) Percent of allowable TCE emissions to date is a time-weighted annual rolling average based on the 500 lb/year emission limit specified in the CRR-NY 212-2.2 Table 2. High Toxicity Air Contaminant List, revised April 1, 2017.

$\mu\text{g}/\text{m}^3$	micrograms per cubic meter
lbs	pounds
CRR-NY	New York Codes, Rules and Regulations
ELAP	Environmental Laboratory Approval Program
NA	not applicable
NYSDOH	New York State Department of Health
T102	Tower 102
TCE	trichloroethene
USEPA	United States Environmental Protection Agency
VOC	volatile organic compound

Table 6A
Summary of AERMOD Air Quality Impact Analysis
Tower 96 Treatment System, Operable Unit 2,
Northrop Grumman Systems Corporation,
Bethpage, New York

Constituent	CAS#	T96 Effluent (ug/m ³)	Emission Rate ⁽¹⁾			Scaled Impact - Hourly ⁽²⁾	Scaled Impact - Annual ⁽²⁾	SGC ⁽³⁾	AGC ⁽³⁾	%SGC	% AGC
		12/13/2017	lb/yr	lb/hr	g/s	(ug/m ³)	(ug/m ³)	(ug/m ³)	(ug/m ³)		
1,1 - Dichloroethene	00075-35-4	2.3 J	0.37	4.20E-05	5.29E-06	7.83E-04	2.30E-05	NS	200	--	0.00%
Trichloroethene ⁽⁴⁾	00079-01-6	10	1.60	1.83E-04	2.30E-05	3.41E-03	9.99E-05	20	2.00E-01	0.02%	0.05%
Vinyl Chloride ⁽⁴⁾	00075-01-4	36	5.80	6.63E-04	8.35E-05	1.24E-02	3.63E-04	180,000	1.10E-01	0.00%	0.33%
Benzene ⁽⁴⁾	00071-43-2	<2.6	--	--	--	--	--	1,300	1.30E-01	--	--
Toluene	00108-88-3	259	41.41	4.73E-03	5.96E-04	8.82E-02	2.59E-03	37,000	5000	0.00%	0.00%
Chloroethane	00075-00-3	2.9	0.46	5.29E-05	6.67E-06	9.87E-04	2.90E-05	NS	10000	--	0.00%
Chloromethane	00074-87-3	1.7	0.27	3.10E-05	3.91E-06	5.79E-04	1.70E-05	22,000	90	0.00%	0.00%

Notes and Abbreviations:

(1) Emission rate calculated based on effluent concentration and a stack air flow rate of 4,840 cfm. The stack air flow rate (in acfm) is taken from the actual stack air flow rate on 12/13/2017.

Effluent temperature used in the model was 90°F from direct read in-line gauge.

Trichloroethene (lb/hr) = (10 ug/m³) x (4,840 ft³/min) x (1 m³/35 ft³) x (60 min/hr) x (0.000001 g/1 ug) x (0.0022 lb/g)

lb/yr = lb/hr x 8,760 hrs/yr

g/s = lb/hr x 1 hr/3,600 sec x 453.59 g/1 lb

(2) Ambient impact based on AERMOD modeling using normalized rate of 1 g/s is scaled to the actual emission rate of the pollutant. Modeling was performed using the representative meteorological data from the nearest station (Farmingdale, NY) for the years 2011 through 2015, and a stack which is 55 feet high and 20 inches in diameter. The maximum impact from all the years was used for the calculations.

Scaled hourly impact (ug/m³) = AERMOD predicted hourly ambient impact at 1 g/s ((ug/m³)/[g/s]) x Actual emission rate (g/s)

Scaled annual impact (ug/m³) = AERMOD predicted annual ambient impact at 1 g/s ((ug/m³)/[g/s]) x Actual emission rate (g/s)

AERMOD Normalized Ambient Impact at 1 g/s	
Hourly ((ug/m ³)/[g/s])	Annual ((ug/m ³)/[g/s])
148.05	4.35

(3) Short-term and annual guideline concentrations for air toxic pollutants specified in the NYSDEC DAR-1 AGC/SGC tables revised August 10, 2016.

(4) Vinyl Chloride and Benzene potential emission rates are less than 0.1 lb/hr and therefore below the trigger emissions for degree of air cleaning requirement (6 CRR-NY 212-2.3). TCE potential emissions are above the trigger limit and require a 12 month rolling average of annual emission to be maintained (see Table 5C) to demonstrate compliance with the 6 CRR-NY 212-2.2 500 lb/year requirement.

AGC	Annual Guideline Concentration	10	bold value indicates a detection
CAS #	Chemical Abstracts Service Registry Number	acfm	actual cubic feet per minute
CRR-NY	New York Codes, Rules and Regulations	g/s	grams per second
DAR-1	Division of Air Resources-1	ug/m ³	micrograms per cubic meter
NS	None Specified	lb/yr	pounds per year
NYSDEC	New York State Department of Environmental Conservation	lb/hr	pounds per hour
SGC	Short-term Guideline Concentration	J	Value is estimated

Table 6B
Summary of AERMOD Air Quality Impact Analysis
Tower 102 Treatment System, Operable Unit 2,
Northrop Grumman Systems Corporation,
Bethpage, New York

Constituent	CAS#	T102 Effluent (ug/m ³)	Emission Rate ⁽¹⁾			Scaled Impact Hourly ⁽²⁾ (ug/m ³)	Scaled Impact Annual ⁽²⁾ (ug/m ³)	SGC ⁽³⁾ (ug/m ³)	AGC ⁽³⁾ (ug/m ³)	%SGC	% AGC
		12/21/2017	lb/yr	lb/hr	g/s						
1,1,1 - Trichloroethane	00071-55-6	0.60	0.15	1.72E-05	2.16E-06	7.55E-04	4.94E-06	9000	5000	0.00%	0.00%
1,1 - Dichloroethane	00075-34-3	21	5.27	6.01E-04	7.57E-05	2.64E-02	1.73E-04	NS	6.30E-01	--	0.03%
1,1 - Dichloroethene	00075-35-4	126	31.60	3.61E-03	4.54E-04	1.59E-01	1.04E-03	NS	200	--	0.00%
Trichloroethene ⁽⁴⁾	00079-01-6	5.3	1.33	1.52E-04	1.91E-05	6.67E-03	4.37E-05	20	2.00E-01	0.03%	0.02%
Vinyl Chloride ⁽⁴⁾	00075-01-4	<0.10	--	--	--	--	--	180000	1.1E-01	--	--
Benzene ⁽⁴⁾	00071-43-2	<0.64	--	--	--	--	--	1300	1.30E-01	--	--
Chloroform	00067-66-3	2.9	0.73	8.30E-05	1.05E-05	3.65E-03	2.39E-05	150	14.7	0.00%	0.00%
Chloromethane	00074-87-3	1.2	0.30	3.44E-05	4.33E-06	1.51E-03	9.89E-06	22000	90	0.00%	0.00%
Dichloromethane	00075-09-2	0.90	0.23	2.58E-05	3.25E-06	1.13E-03	7.42E-06	14000	60	0.00%	0.00%
Trichlorotrifluoroethane (Freon 113)	00076-13-1	28	7.02	8.02E-04	1.01E-04	3.52E-02	2.31E-04	960000	180000	0.00%	0.00%

Notes and Abbreviations:

(1) Emission rate calculated based on effluent concentration and a stack air flow rate of 7,590cfm. The stack air flow rate (in acfm) is taken from the actual stack air flow rate on 12/21/2017.

Effluent temperature used in the model was 86°F from direct read in-line gauge.

Trichloroethene (lb/hr) = (5.3 ug/m³) x (7,590 ft³/min) x (1 m³/35 ft³) x (60 min/hr) x (0.000001 g/1 ug) x (0.0022 lb/g)

lb/yr = lb/hr x 8,760 hrs/yr

g/s = lb/hr x 1 hr/3,600 sec x 453.59 g/1 lb

(2) Ambient impact based on AERMOD modeling using normalized rate of 1 g/s is scaled to the actual emission rate of the pollutant. Modeling was performed using the representative meteorological data from the nearest station (Farmingdale, NY) for the years 2011 through 2015, and a stack which is 69.52 feet high and 24 inches in diameter. The maximum impact from all the years was used for the calculations.

Scaled hourly impact (ug/m³) = AERMOD predicted hourly ambient impact at 1 g/s ((ug/m³)/[g/s]) x Actual emission rate (g/s)

Scaled annual impact (ug/m³) = AERMOD predicted annual ambient impact at 1 g/s ((ug/m³)/[g/s]) x Actual emission rate (g/s)

AERMOD Normalized Ambient Impact at 1 g/s	
Hourly ((ug/m ³)/[g/s])	Annual ((ug/m ³)/[g/s])
348.85	2.29

(3) Short-term and annual guideline concentrations for air toxic pollutants specified in the NYSDEC DAR-1 AGC/SGC tables revised August 10, 2016.

(4) Vinyl Chloride and Benzene potential emission rates are less than 0.1 lb/hr and therefore below the trigger emissions for degree of air cleaning requirement (6 CRR-NY 212-2.3). TCE potential emissions are above the trigger limit and require a 12 month rolling average of annual emission to be maintained (see Table 5D) to demonstrate compliance with the 6 CRR-NY 212-2.2 500 lb/year requirement.

AGC	Annual Guideline Concentration	21	bold value indicates a detection
CAS #	Chemical Abstracts Service Registry Number	acfm	actual cubic feet per minute
CRR-NY	New York Codes, Rules and Regulations	g/s	grams per second
DAR-1	Division of Air Resources-1	ug/m ³	micrograms per cubic meter
NS	None Specified	lb/yr	pounds per year
NYSDEC	New York State Department of Environmental Conservation	lb/hr	pounds per hour
SGC	Short-term Guideline Concentration		

Table 7
Summary of SPDES Equivalency Effluent Water⁽¹⁾ Sample Analytical Results 2017,
ONCT Treatment System, Operable Unit 2,
Northrop Grumman Systems Corporation,
Bethpage, New York

PARAMETER	Units	Discharge Limit ⁽²⁾	Location ID: Sample ID: Sample Date:	Outfall 005 Outfall 005 1/19/2017	Outfall 005 Outfall 005 2/14/2017	Outfall 005 Outfall 005 3/21/2017	Outfall 005 Outfall 005 4/14/2017	Outfall 005 Outfall 005 5/11/2017	Outfall 005 Outfall 005 6/29/2017
<u>Volatile Organic Compounds (VOCs)⁽³⁾</u>									
1,1,1-Trichloroethane	µg/L	5		<0.50	<0.50	<0.50	<0.50	<0.50	<0.50
1,1,2-Trichlorotrifluoroethane (Freon 113)	µg/L	5		<0.50	<0.50	<0.50	<0.50	<0.50	<0.50
1,1-Dichloroethene	µg/L	5		<0.50	<0.50	<0.50	<0.50	<0.50	<0.50
cis-1,2-dichloroethene	µg/L	5		<0.50	0.64	<0.50	<0.50	<0.50	0.62
Methylene Chloride	µg/L	5		<0.50	<0.50	<0.50	<0.50	<0.50	<0.50
Tetrachloroethene	µg/L	5		<0.50	<0.50	<0.50	<0.50	<0.50	<0.50
trans-1,2-dichloroethene	µg/L	5		<0.50	<0.50	<0.50	<0.50	<0.50	<0.50
Trichloroethene	µg/L	5		1.3	1.3	1.1	1.8	1.5	1.5
Vinyl Chloride	µg/L	2		<0.50	<0.50	<0.50	<0.50	<0.50	<0.50
TVOCs⁽⁴⁾				1.3	1.9	1.1	1.8	1.5	2.1
<u>Semivolatile Organic Compounds (SVOCs)⁽⁹⁾</u>									
1,4-Dioxane	µg/L	NA / Monitor		--	--	--	--	--	--
Anions⁽⁵⁾									
Nitrogen, (Nitrate+Nitrite)	mg/L	NA		4.6	4.5	4.5	4.4	4.6	4.4
Nitrogen, Total Kjeldahl	mg/L	NA		0.99	<0.20	1.4	<0.20	<0.20	<0.20
Total Nitrogen	mg/L	10		5.6	4.5	5.9	4.5	4.6	4.4
pH - Intake (Tower 102)	S.U.	NA		5.42	5.24	5.35	5.51	5.28	5.32 ⁽⁷⁾
pH - Effluent⁽⁶⁾	S.U.	6.5 - 8.5		6.32	6.59	6.10	6.70	6.02	6.90

Notes and Abbreviations on last page.

Table 7
Summary of SPDES Equivalency Effluent Water⁽¹⁾ Sample Analytical Results 2017,
ONCT Treatment System, Operable Unit 2,
Northrop Grumman Systems Corporation,
Bethpage, New York

PARAMETER	Units	Discharge Limit ⁽²⁾	Location ID: Sample ID: Sample Date:	Outfall 005 Outfall 005 7/18/2017	Outfall 005 Outfall 005 8/25/2017	Outfall 005 Outfall 005 9/13/2017	Outfall 005 Outfall 005 10/17/2017	Outfall 005 Outfall 005 11/21/2017	Outfall 005 Outfall 005 12/21/2017
<u>Volatile Organic Compounds (VOCs)⁽³⁾</u>									
1,1,1-Trichloroethane (TCA)	µg/L	5		<0.50	<0.50	<0.50	<0.50	<0.50	<0.50
1,1,2-Trichlorotrifluoroethane (Freon 113)	µg/L	5		<0.50	<0.50	<0.50	<0.50	<0.50	<0.50
1,1-Dichloroethene (1,1-DCE)	µg/L	5		<0.50	<0.50	<0.50	<0.50	<0.50	<0.50
cis-1,2-dichloroethene	µg/L	5		<0.50	<0.50	<0.50	<0.50	<0.55	<0.50
Methylene Chloride	µg/L	5		<0.50	<0.50	<0.50	<0.50	<0.50	<0.50
Tetrachloroethene (PCE)	µg/L	5		<0.50	<0.50	<0.50	<0.50	<0.50	<0.50
trans-1,2-dichloroethene	µg/L	5		<0.50	<0.50	<0.50	<0.50	<0.50	<0.50
Trichloroethene (TCE)	µg/L	5		1.1	1.5	1.4	1.3	1.2	1.5
Vinyl Chloride	µg/L	2		<0.50	<0.50	<0.50	<0.50	<0.50	<0.50
TVOCs⁽⁴⁾				1.1	1.5	1.4	1.3	1.2	1.5
<u>Semivolatile Organic Compounds (SVOCs)⁽⁹⁾</u>									
1,4-Dioxane	µg/L	NA / Monitor		--	--	--	--	8.4	7.6
<u>Anions⁽⁵⁾</u>									
Nitrogen, (Nitrate+Nitrite)	mg/L	NA		0.93	4.4	4.4	4.3	4.3	4.5
Nitrogen, Total Kjeldahl	mg/L	NA		<0.20	<0.20	<0.20	<0.20	<0.20	<0.20
Total Nitrogen	mg/L	10		0.93	4.4	4.4	4.3	4.3	4.5
pH - Intake (Tower 102)	S.U.	NA		5.40	5.20	5.25	5.42	5.46	5.70
pH - Effluent⁽⁶⁾	S.U.	6.5 - 8.5		6.50	6.50	6.51	6.30	6.47	6.66

Notes and Abbreviations on last page.

Table 7
Summary of SPDES Equivalency Effluent Water⁽¹⁾ Sample Analytical Results 2017,
ONCT Treatment System, Operable Unit 2,
Northrop Grumman Systems Corporation,
Bethpage, New York

PARAMETER	Units	Discharge Limit ⁽²⁾	Location ID: Sample ID: Sample Date:	Outfall 006 Outfall 006 1/19/2017	Outfall 006 Outfall 006 2/14/2017	Outfall 006 Outfall 006 3/21/2017	Outfall 006 Outfall 006 4/14/2017	Outfall 006 Outfall 006 5/11/2017	Outfall 006 Outfall 006 6/29/2017
<u>Volatile Organic Compounds (VOCs)⁽³⁾</u>									
1,1,1-Trichloroethane (TCA)	µg/L	5		<0.50	<0.50	<0.50	<0.50	<0.50	<0.50
1,1,2-Trichlorotrifluoroethane (Freon 113)	µg/L	5		<0.50	<0.50	<0.50	<0.50	<0.50	<0.50
1,1-Dichloroethene (1,1-DCE)	µg/L	5		<0.50	<0.50	<0.50	<0.50	<0.50	<0.50
cis-1,2-dichloroethene	µg/L	5		<0.50	<0.50	<0.50	<0.50	<0.50	<0.50
Methylene Chloride	µg/L	5		<0.50	<0.50	<0.50	<0.50	<0.50	<0.50
Tetrachloroethene (PCE)	µg/L	5		<0.50	<0.50	<0.50	<0.50	<0.50	<0.50
trans-1,2-dichloroethene	µg/L	5		<0.50	<0.50	<0.50	<0.50	<0.50	<0.50
Trichloroethene (TCE)	µg/L	5		1.8	1.5	0.41 J	<0.50	<0.50	<0.50
Vinyl Chloride	µg/L	2		<0.50	<0.50	<0.50	<0.50	<0.50	<0.50
TVOCs⁽⁴⁾				1.8	1.5	0.41	0.0	0.0	0.0
<u>Semivolatile Organic Compounds (SVOCs)⁽⁹⁾</u>									
1,4-Dioxane	µg/L	NA / Monitor		--	--	--	--	--	--
<u>Anions⁽⁵⁾</u>									
Nitrogen, (Nitrate+Nitrite)	mg/L	NA		5.4	5.1	4.9	5.0	5.4	5.1
Nitrogen, Total Kjeldahl	mg/L	NA		<0.20	<0.20	0.59	<0.20	<0.20	<0.20
Total Nitrogen	mg/L	10		5.4	5.1	5.5	5.0	5.4	5.1
pH - Intake (Tower 96)	S.U.	NA		5.42	5.60	5.75	5.51	5.10	5.33 ⁽⁷⁾
pH - Effluent⁽⁶⁾	S.U.	6.5 - 8.5		6.38	6.58	6.10	6.80	5.93	6.60

Notes and Abbreviations on last page.

Table 7
Summary of SPDES Equivalency Effluent Water⁽¹⁾ Sample Analytical Results 2017,
ONCT Treatment System, Operable Unit 2,
Northrop Grumman Systems Corporation,
Bethpage, New York

PARAMETER	Units	Discharge Limit ⁽²⁾	Location ID: Sample ID: Sample Date:	Outfall 006 Outfall 006 7/18/2017	Outfall 006 Outfall 006 8/25/2017	Outfall 006 DUP-082517-PR-1 8/25/2017	Outfall 006 Outfall 006 9/13/2017	Outfall 006 Outfall 006 10/17/2017	Outfall 006 Outfall 006 11/21/2017	Outfall 006 Outfall 006 12/21/2017
<u>Volatile Organic Compounds (VOCs)⁽³⁾</u>										
1,1,1-Trichloroethane (TCA)	µg/L	5		<0.50	<0.50	<0.50	<0.50	<0.50	<0.50	<0.50
1,1,2-Trichlorotrifluoroethane (Freon 113)	µg/L	5		<0.50	<0.50	<0.50	<0.50	<0.50	<0.50	<0.50
1,1-Dichloroethene (1,1-DCE)	µg/L	5		<0.50	<0.50	<0.50	<0.50	<0.50	<0.50	<0.50
cis-1,2-dichloroethene	µg/L	5		<0.50	<0.50	<0.50	<0.50	<0.50	<0.55	<0.50
Methylene Chloride	µg/L	5		<0.50	<0.50	<0.50	<0.50	<0.50	<0.50	<0.50
Tetrachloroethene (PCE)	µg/L	5		<0.50	<0.50	<0.50	<0.50	<0.50	<0.50	<0.50
trans-1,2-dichloroethene	µg/L	5		<0.50	<0.50	<0.50	<0.50	<0.50	<0.50	<0.50
Trichloroethene (TCE)	µg/L	5		<0.50	<0.50	<0.50	<0.50	0.31 J	0.69	0.73
Vinyl Chloride	µg/L	2		<0.50	<0.50	<0.50	<0.50	<0.50	<0.50	<0.50
TVOCs⁽⁴⁾				0.0	0.0	0.0	0.0	0.31	0.69	0.73
<u>Semivolatile Organic Compounds (SVOCs)⁽⁹⁾</u>										
1,4-Dioxane	µg/L	NA / Monitor		--	--	--	--	--	12.4	9.89 J
<u>Anions⁽⁵⁾</u>										
Nitrogen, Nitrate+Nitrite	mg/L	NA		2.4	4.9	--	4.9	4.9	4.8	4.8
Nitrogen, Total Kjeldahl	mg/L	NA		<0.20	0.25	--	<0.20	<0.20	0.22	<0.20
Total Nitrogen	mg/L	10		2.4	5.2	--	4.9	4.9	5.0	4.8
pH - Intake (Tower 96)	mg/L	NA		5.30	5.30	--	5.27	5.52	5.35	5.61
pH - Effluent⁽⁶⁾	mg/L	6.5 - 8.5		6.57	6.50	--	6.61	6.31	6.41	6.98

Notes and Abbreviations on last page.

Table 7
Summary of SPDES Effluent Water Sample Analytical Results 2016,
ONCT Treatment System, Operable Unit 2,
Northrop Grumman Systems Corporation,
Bethpage, New York

Notes and Abbreviations:

- (1) SPDES effluent water samples are collected at a point closest to the respective Outfalls to each of the recharge basins, not directly from the treatment system tower effluent ports.
 - (2) Discharge limits are per the SPDES permit dated March 1, 1996 and subsequent renewals, except for 1,4-Dioxane, which was added as an analytical parameter, in November of 2017 (see note 9)
 - (3) Samples were analyzed for permit specified VOCs using USEPA Method 624.
 - (4) TVOC represents the sum of individual concentrations of VOCs detected. Results rounded to two significant figures.
 - (5) Samples were analyzed for Nitrogen, (Nitrate+Nitrite) and Total Kjeldahl Nitrogen (TKN) by USEPA Methods 353.2 and 351.2, respectively. Total Nitrogen is calculated as the sum of Nitrogen, (Nitrate+Nitrite) and TKN concentrations and is rounded to two significant figures.
 - (6) As per the SPDES permit, when natural groundwater has a pH outside the range indicated, the natural pH may be one extremity of the allowable range. In such cases the untreated groundwater and outfall pH must be sampled and reported monthly on the Discharge Monitoring Reports (DMRs).
 - (7) Influent pH based on flow weighted average of applicable individual well pH levels.
 - (8) Total Nitrogen values adjusted from laboratory/permit reported values due to erroneous calculations by laboratory. Total Nitrogen is the sum of the Nitrogen,(Nitrate +Nitrite) and Total Kjeldahl Nitrogen for each event.
 - (9) A SPEDES equivalency letter was issued October 2017, at that time 1,4-Dioxane was added to the analyte list. Discussion regarding pH and other analytes are ongoing with NYSDEC, Basin Discharges are still being reported under SPDES Permit.
- Not Analyzed
- 1.5** Value indicates a detection.
- < 0.50 Compound not detected above its laboratory quantification limit.
- µg/L micrograms per liter
- mg/L milligrams per liter
- J Constituent value is estimated
- DUP Field Duplicate Sample
- NA Not Applicable
- ONCT On-Site Containment System
- S.U. Standard Units
- SPDES State Pollution Discharge Elimination System
- USEPA United States Environmental Protection Agency
- VOCs Volatile Organic Compounds
- SVOCs Semivolatile Organic Compounds

Table 8
Water-Level Measurement Data and Remedial Well
Specific Capacities, April 3 to April 11, 2017
Operable Unit 2, Northrop Grumman Systems Corporation,
Bethpage, New York

Well Identification	Measuring Point Elevation (ft msl)	Depth to Water (ft bmp)	Water-Level Elevation (ft msl)
Shallow Wells⁽¹⁾			
FW-03	124.30	59.82	64.48
N-9921	94.23	NM	NM
N-10597	109.85	43.81	66.04
N-10600 ⁽²⁾	102.41	42.07	60.34
N-10631	103.47	42.10	61.37
N-10633	103.80	43.35	60.45
N-10634	101.20	43.58	57.62
N-10821	91.58	NM	NM
GM-15SR	109.35	49.08	60.27
GM-15I	109.29	48.83	60.46
GM-16SR	115.86	50.30	65.56
GM-17I	115.83	46.55	69.28
GM-17SR	115.79	46.31	69.48
GM-18S	107.60	44.33	63.27
GM-18I	109.03	45.25	63.78
GM-19S	109.86	47.33	62.53
GM-20I	103.88	40.54	63.34
GM-21S	105.81	40.61	65.20
GM-74I	107.42	44.02	63.40
GM-78S	104.94	44.43	60.51
GM-78I	105.06	44.78	60.28
GM-79S (N-10628)	100.88	43.55	57.33
HN-24S	122.73	54.94	67.79
HN-40S	116.35	53.15	63.20
HN-40I	115.91	52.89	63.02
HN-42S	120.32	55.48	64.84
HN-42I	119.61	54.83	64.78
MW-3R	101.45	38.35	63.10
Intermediate Wells⁽¹⁾			
GM-16I	115.81	50.48	65.33
GM-19I	109.86	47.57	62.29
GM-21I	105.72	42.45	63.27
HN-24I	125.80	55.92	69.88
HN-29I	116.42	50.42	66.00
Deep Wells⁽¹⁾			
N-10624	93.61	35.79	57.82
N-10627	93.70	36.27	57.43
GM-13D	113.97	49.32	64.65
GM-15D	109.84	51.28	58.56
GM-17D	115.68	52.04	63.64
GM-18D	108.88	48.38	60.50
GM-20D	103.92	42.28	61.64
GM-21D	105.66	46.86	58.80

See Notes and Abbreviations on last page

Table 8
Water-Level Measurement Data and Remedial Well
Specific Capacities, April 3 to April 11, 2017
Operable Unit 2, Northrop Grumman Systems Corporation,
Bethpage, New York

Well Identification	Measuring Point Elevation (ft msl)	Depth to Water (ft bmp)	Water-Level Elevation (ft msl)
Deep Wells (continued)⁽¹⁾			
GM-36D	91.63	37.88	53.75
GM-37D	97.26	42.69	54.57
GM-38D	91.75	42.41	49.34
GM-39D _A	102.23	42.23	60.00
GM-70D2	99.58	44.81	54.77
GM-74D	107.43	49.02	58.41
GM-79I	101.09	44.10	56.99
GM-79D	101.25	45.42	55.83
HN-29D	115.11	50.50	64.61
BPOW1-1	73.65	31.90	41.75
BPOW1-2	73.54	33.74	39.80
Deep2 Wells⁽¹⁾			
GM-15D2	109.78	53.71	56.07
GM-33D2	106.85	52.62	54.23
GM-34D	71.19	17.43	53.76
GM-34D2	71.19	20.04	51.15
GM-35D2	96.28	44.18	52.10
GM-36D2	91.60	41.46	50.14
GM-37D2	97.17	43.26	53.91
GM-38D2	91.56	43.37	48.19
GM-39D _B	102.08	44.95	57.13
GM-71D2	98.45	45.21	53.24
GM-73D	104.87	47.48	57.39
GM-73D2	104.62	49.37	55.25
GM-74D2	107.36	55.99	51.37
GM-75D2	93.63	39.52	54.11
GM-78D	103.81	46.94	56.87
GM-78D2	103.82	48.92	54.90
GM-21D2	104.62	52.22	52.40
MW 3-1	115.28	59.22	56.06
TT-101D	47.27	NM	NM
TT-101D1	116.78	NM	NM
TT-102D	49.96	20.50	29.46
Well 1	116.78	89.10	27.68
Well 3R ⁽⁴⁾	115.28	83.30	31.98
Well 17	104.10	67.10	37.00
Well 18	110.00	74.10	35.90
Well 19	108.70	69.50	39.20
BPOW1-3	71.92	33.92	38.00
BPOW1-4	56.68	15.30	41.38
BPOW2-1	58.64	22.31	36.33
BPOW2-2	58.50	24.76	33.74
BPOW2-3	57.98	24.49	33.49

See Notes and Abbreviations on last page

Table 8
Water-Level Measurement Data and Remedial Well
Specific Capacities, April 3 to April 11, 2017
Operable Unit 2, Northrop Grumman Systems Corporation,
Bethpage, New York

Well Identification	Measuring Point Elevation (ft msl)	Depth to Water (ft bmp)	Water-Level Elevation (ft msl)
Deep2 Wells⁽¹⁾ (continued)			
BPOW3-1	61.43	26.39	35.04
BPOW3-2	61.82	27.48	34.34
BPOW3-3	60.64	26.39	34.25
RE123D1 ⁽⁵⁾	105.49	49.53	55.96
RE126D1 ⁽⁵⁾	101.03	47.28	53.75
RE126D2 ⁽⁵⁾	101.74	48.34	53.40
RE126D3 ⁽⁵⁾	101.66	48.01	53.65
Deep 3 Wells⁽¹⁾			
GM-73D3	103.88	49.49	54.39
GM-74D3	106.56	53.64	52.92
BPOW1-5	56.75	15.63	41.12
BPOW1-6	57.06	15.94	41.12
BPOW3-4	62.44	26.01	36.43
BPOW4-1R ⁽⁶⁾	67.34	24.96	42.38
BPOW4-2R ⁽⁶⁾	67.18	26.73	40.45
TT-101D2	80.89	NM	NM
TT-102D2	44.12	14.98	29.14
RE123D2 ⁽⁵⁾	106.11	50.83	55.28
RE123D3 ⁽⁵⁾	105.92	50.65	55.27

Remedial Well Specific Capacities⁽⁷⁾

Well ID	Static Depth to Water (ft bmp) ⁽⁸⁾	Pumping Depth to Water (ft bmp)	Drawdown (ft)	Second Quarter 2017 Pumping Rate (Q)(gpm) ⁽⁹⁾	Specific Capacity (Q/s)(gpm/ft)
Well 1	51.14	89.10	37.96	806	21.23
Well 3R	52.66	83.30	30.64	709	23.14
Well 17	44.12	67.10	22.98	1004	43.69
Well 18	50.15	74.10	23.95	818	34.15
Well 19	49.13	69.50	20.37	701	34.41

See Notes and Abbreviations on last page

Notes and Abbreviations:

- (1) Well identification (e.g., GM-70D2) does not necessarily designate the actual hydrogeologic zone. Determination of the hydrogeologic zones is based on the well screen interval and the regional model layering.
 - (2) Well was not accessible as drill rig was staged on top of well location considered anomalous. All OU2 ONCT wells were pumping at regular pumping rates on December 19, 2016.
 - (3) Monitoring wells were voluntarily monitored to enhance coverage in the Deep and Deep2 zones.
 - (4) Surveyed elevation not available, elevation is estimated from topographic maps of the area.
 - (5) Water level data for this well was collected by Navy between June 3 and June 5, 2017 and was provided to Arcadis
 - (6) The NAVY abandoned original Wells BPOW4-1 and BPOW4-2 and installed replacement Wells BPOW4-1R and BPOW4-2R between August, 2014 and October, 2014.
 - (7) Specific capacity values are qualitative in nature, due to fluctuations in static water levels. Sharp declines in specific capacity could indicate the need for well redevelopment.
 - (8) For Wells 17, 18, and 19, baseline static depth to water measurements were collected in 1997 prior to OU2 system start-up; baseline pumping depth to water and rate measurements (not shown) used with baseline static depth to water measurements to calculate baseline specific capacities, were collected in 1999 during OU2 system operation. For Well 1, baseline static depth to water was collected on 9/24/2012, when pump was offline due to well maintenance activities. For Well 3R, baseline static depth to water was collected on 12/2/2013, when pump was offline during well installation activities and prior to start up.
 - (9) Pumping rate determined at time of pumping depth to water measurement.
- ft msl feet relative to mean sea level
ft bmp feet below measuring point
OU2 Operable Unit 2
gpm gallons per minute
NM not measured
Q pumping rate
S drawdown

Table 9
Water-Level Measurement Data and Remedial
Well Specific Capacities, October 10 to October 13, 2017
Operable Unit 2, Northrop Grumman Systems Corporation,
Bethpage, New York

Well Identification	Measuring Point Elevation (ft msl)	Depth to Water (ft bmp)	Water-Level Elevation (ft msl)
Shallow Wells⁽¹⁾			
FW-03	124.30	59.89	64.41
N-9921	94.23	NM	NM
N-10597	109.85	44.15	65.70
N-10600 ⁽²⁾	102.41	42.03	NM
N-10631	103.47	42.85	60.62
N-10633	103.80	44.08	59.72
N-10634	101.20	43.83	57.37
N-10821	91.58	NM	NM
GM-15SR	109.35	49.21	60.14
GM-15I	109.29	48.93	60.36
GM-16SR	115.86	50.47	65.39
GM-17I	115.83	45.75	70.08
GM-17SR	115.79	45.72	70.07
GM-18S	107.60	44.79	62.81
GM-18I	109.03	45.55	63.48
GM-19S	109.86	47.70	62.16
GM-20I	103.88	43.05	60.83
GM-21S	105.81	42.80	63.01
GM-74I	107.42	45.08	62.34
GM-78S	104.94	44.68	60.26
GM-78I	105.06	45.00	60.06
GM-79S (N-10628)	100.88	43.64	57.24
HN-24S	122.73	55.13	67.60
HN-40S	116.35	53.14	63.21
HN-40I	115.91	52.93	62.98
HN-42S	120.32	55.58	64.74
HN-42I	119.61	54.90	64.71
MW-3R	101.45	40.97	60.48
Intermediate Wells⁽¹⁾			
GM-16I	115.81	50.64	65.17
GM-19I	109.86	48.15	61.71
GM-21I	105.72	42.1	63.62
HN-24I	125.80	56.14	69.66
HN-29I	116.42	56.69	59.73
Deep Wells⁽¹⁾			
N-10624	93.61	35.72	57.89
N-10627	93.70	36.22	57.48
GM-13D	113.97	49.60	64.37
GM-15D	109.84	51.24	58.60
GM-17D	115.68	51.95	63.73
GM-18D	108.88	48.35	60.53
GM-20D	103.92	43.85	60.07
GM-21D	105.66	47.30	58.36
GM-36D	91.63	38.20	53.43
GM-37D	97.26	42.49	54.77
GM-38D	91.75	42.50	49.25
GM-39D _A ⁽³⁾	102.23	43.90	58.33
GM-70D2	99.58	44.73	54.85

See Notes and Abbreviations on last page

Table 9
Water-Level Measurement Data and Remedial
Well Specific Capacities, October 10 to October 13, 2017
Operable Unit 2, Northrop Grumman Systems Corporation,
Bethpage, New York

Well Identification	Measuring Point Elevation (ft msl)	Depth to Water (ft bmp)	Water-Level Elevation (ft msl)
Deep Wells (continued)⁽¹⁾			
GM-74D	107.43	49.22	58.21
GM-79I	101.09	44.09	57.00
GM-79D	101.25	45.23	56.02
HN-29D	115.66	50.86	64.80
BPOW1-1	73.65	32.17	41.48
BPOW1-2	73.54	33.26	40.28
Deep2 Wells⁽¹⁾			
GM-15D2	109.78	53.20	56.58
GM-33D2	106.85	52.43	54.42
GM-34D	71.19	17.73	53.46
GM-34D2	71.19	19.92	51.27
GM-35D2	96.28	43.11	53.17
GM-36D2	91.60	40.75	50.85
GM-37D2	97.17	43.20	53.97
GM-38D2	91.56	43.85	47.71
GM-39D _B ⁽³⁾	102.08	43.30	58.78
GM-71D2	98.45	44.87	53.58
GM-73D	104.87	47.45	57.42
GM-73D2	104.62	49.10	55.52
GM-74D2	107.36	54.95	52.41
GM-75D2	93.63	39.10	54.53
GM-78D	103.81	46.97	56.84
GM-78D2	103.82	48.80	55.02
GM-21D2	104.62	51.05	53.57
MW 3-1	115.28	59.67	55.61
TT-102D	49.96	23.66	26.30
Well 1	116.78	89.00	27.78
Well 3R ⁽⁴⁾	115.28	85.60	29.68
Well 17	104.10	66.70	37.40
Well 18	110.00	65.80	44.20
Well 19	108.70	64.30	44.40
BPOW1-3	71.92	33.38	38.54
BPOW1-4	56.68	15.50	41.18
BPOW2-1	58.64	23.52	35.12
BPOW2-2	58.50	26.36	32.14
BPOW2-3	57.98	23.45	34.53
BPOW3-1	61.43	30.05	31.38
BPOW3-2	61.82	31.65	30.17
BPOW3-3	60.64	27.55	33.09
RE123D1 ⁽⁵⁾	105.49	49.10	56.39
RE126D1 ⁽⁵⁾	101.03	47.16	53.87
RE126D2 ⁽⁵⁾	101.39	47.71	53.68
RE126D3 ⁽⁵⁾	101.10	47.46	53.64

See Notes and Abbreviations on last page

Table 9
Water-Level Measurement Data and Remedial
Well Specific Capacities, October 10 to October 13, 2017
Operable Unit 2, Northrop Grumman Systems Corporation,
Bethpage, New York

Well Identification	Measuring Point Elevation (ft msl)	Depth to Water (ft bmp)	Water-Level Elevation (ft msl)
Deep 3 Wells⁽¹⁾			
GM-73D3	103.88	49.10	54.78
GM-74D3	106.56	52.62	53.94
BPOW1-5	56.75	16.17	40.58
BPOW1-6	57.06	16.50	40.56
BPOW3-4	62.44	29.35	33.09
BPOW4-1R ⁽⁶⁾	67.34	30.59	36.75
BPOW4-2R ⁽⁶⁾	67.18	30.50	36.68
TT-102D2	44.12	18.35	25.77
RE123D2 ⁽⁵⁾	106.11	50.18	55.93
RE123D3 ⁽⁵⁾	105.92	50.40	55.52

Remedial Well Specific Capacities⁽⁷⁾					
Well ID	Static Depth to Water (ft bmp) ⁽⁸⁾	Pumping Depth to Water (ft bmp)	Drawdown (ft)	Fourth Quarter 2017 Pumping Rate (Q)(gpm) ⁽⁹⁾	Specific Capacity (Q/s)(gpm/ft)
Well 1	51.14	89.00	37.86	806	21.29
Well 3R	52.66	85.60	32.94	717	21.77
Well 17	44.12	66.70	22.58	1001	44.33
Well 18	50.15	65.80	15.65	515	32.91
Well 19	49.13	64.30	15.17	510	33.62

See Notes and Abbreviations on last page

Notes and Abbreviations:

- (1) Well identification (e.g., GM-70D2) does not necessarily designate the actual hydrogeologic zone. Determination of the hydrogeologic zones is based on the well screen interval and the regional model layering.
 - (2) Well was not accessible as drill rig was staged on top of well location considered anomalous. All OU2 ONCT wells were pumping at regular pumping rates on December 19, 2016.
 - (3) Monitoring wells were voluntarily monitored to enhance coverage in the Deep and Deep2 zones.
 - (4) Surveyed elevation not available, elevation is estimated from topographic maps of the area.
 - (5) Water level data for this well was collected by Navy on December 4, 2017 and was provided to Arcadis
 - (6) The NAVY abandoned original Wells BPOW4-1 and BPOW4-2 and installed replacement Wells BPOW4-1R and BPOW4-2R between August, 2014 and October, 2014.
 - (7) Specific capacity values are qualitative in nature, due to fluctuations in static water levels. Sharp declines in specific capacity could indicate the need for well redevelopment.
 - (8) For Wells 17, 18, and 19, baseline static depth to water measurements were collected in 1997 prior to OU2 system start-up; baseline pumping depth to water and rate measurements (not shown) used with baseline static depth to water measurements to calculate baseline specific capacities, were collected in 1999 during OU2 system operation. For Well 1, baseline static depth to water was collected on 9/24/2012, when pump was offline due to well maintenance activities. For Well 3R, baseline static depth to water was collected on 12/2/2013, when pump was offline during well installation activities and prior to start up.
 - (9) Pumping rate determined at time of pumping depth to water measurement.
- ft msl feet relative to mean sea level
ft bmp feet below measuring point
OU2 Operable Unit 2
gpm gallons per minute
NM not measured
Q pumping rate
S drawdown

Table 10
Concentrations of Volatile Organic Compounds in Groundwater
Samples Collected from Wells in the Shallow Zone ⁽¹⁾,
Operable Unit 2, Northrop Grumman Systems Corporation,
Bethpage, New York

Constituents units in (ug/L)	Well ID: Sample ID: Sample Date:	FW-03 FW-03 4/17/2017	GM-15SR GM-15SR 6/28/2017	GM-15SR GM-15SR 11/2/2017	GM-15I GM-15I 6/28/2017	GM-15I GM-15I 11/2/2017	GM-17I GM-17I 5/2/2017	GM-17I GM-17I 11/1/2017	GM-18I GM-18I 7/11/2017	GM-18I GM-18I 10/31/2017	GM-20I GM-20I 4/25/2017	GM-21S GM-21S 6/21/2017	GM-74I GM-74I 5/2/2017
	NYSDEC SCGs (ug/L) ⁽²⁾												
1,1,1-Trichloroethane	5	<1.0	< 1.0	< 1.0	< 1.0	< 1.0	< 1.0	< 1.0	< 1.0	< 1.0	<1.0	<1.0	< 1.0
1,1,2,2-Tetrachloroethane	5	<1.0	< 1.0	< 1.0	< 1.0	< 1.0	< 1.0	< 1.0	< 1.0	< 1.0	<1.0	<1.0	< 1.0
1,1,2-Trichloroethane	5	<1.0	< 1.0	< 1.0	< 1.0	< 1.0	< 1.0	< 1.0	< 1.0	< 1.0	<1.0	<1.0	< 1.0
1,1-Dichloroethane	5	<1.0	< 1.0	< 1.0	< 1.0	< 1.0	< 1.0	< 1.0	< 1.0	< 1.0	<1.0	<1.0	< 1.0
1,1-Dichloroethene	5	<1.0	< 1.0	< 1.0	< 1.0	< 1.0	< 1.0	< 1.0	< 1.0	< 1.0	<1.0	<1.0	< 1.0
1,2-Dichloroethane	5	<1.0	< 1.0	< 1.0	< 1.0	< 1.0	< 1.0	< 1.0	< 1.0	< 1.0	<1.0	<1.0	< 1.0
1,2-Dichloropropane	5	<1.0	< 1.0	< 1.0	< 1.0	< 1.0	< 1.0	< 1.0	< 1.0	< 1.0	<1.0	<1.0	< 1.0
2-Butanone	50	<10	< 10	< 10	< 10	< 10	< 10	< 10	< 10	< 10	<10	<10	< 10
2-Hexanone	50	<5.0	< 5.0	< 5.0	< 5.0	< 5.0	< 5.0	< 5.0	< 5.0	< 5.0	<5.0	<5.0	< 5.0
4-methyl-2-pentanone	50	<5.0	< 5.0	< 5.0	< 5.0	< 5.0	< 5.0	< 5.0	< 5.0	< 5.0	<5.0	<5.0	< 5.0
Acetone	50	<10	< 10	< 10	< 10	< 10	< 10	< 10	< 10	< 10	<10	<10	< 10
Benzene	1	<0.50	< 0.50	< 0.50	< 0.50	< 0.50	< 0.50	< 0.50	< 0.50	< 0.50	<0.50	<0.50	< 0.50
Bromodichloromethane	50	<1.0	< 1.0	< 1.0	< 1.0	< 1.0	< 1.0	< 1.0	< 1.0	< 1.0	<1.0	<1.0	< 1.0
Bromoform	50	<1.0	< 1.0	< 1.0	< 1.0	< 1.0	< 1.0	< 1.0	< 1.0	< 1.0	<1.0	<1.0	< 1.0
Bromomethane	5	<2.0	< 2.0	< 2.0	< 2.0	< 2.0	< 2.0	< 2.0	< 2.0	< 2.0	<2.0	<2.0	< 2.0
Carbon Disulfide	50	<2.0	< 2.0	< 2.0	< 2.0	< 2.0	< 2.0	< 2.0	< 2.0	< 2.0	<2.0	<2.0	< 2.0
Carbon tetrachloride	5	<1.0	< 1.0	< 1.0	< 1.0	< 1.0	< 1.0	< 1.0	< 1.0	< 1.0	<1.0	<1.0	< 1.0
Chlorobenzene	5	<1.0	< 1.0	< 1.0	< 1.0	< 1.0	< 1.0	< 1.0	< 1.0	< 1.0	<1.0	<1.0	< 1.0
Chloroethane	5	<1.0	< 1.0	< 1.0	< 1.0	< 1.0	< 1.0	< 1.0	< 1.0	< 1.0	<1.0	<1.0	< 1.0
Chloroform	7	<1.0	< 1.0	< 1.0	< 1.0	< 1.0	< 1.0	< 1.0	< 1.0	< 1.0	<1.0	<1.0	< 1.0
Chloromethane	5	<1.0	< 1.0	< 1.0	< 1.0	< 1.0	< 1.0	< 1.0	< 1.0	< 1.0	<1.0	<1.0	< 1.0
cis-1,2-dichloroethene	5	<1.0	< 1.0	< 1.0	< 1.0	< 1.0	< 1.0	< 1.0	< 1.0	< 1.0	<1.0	<1.0	< 1.0
cis-1,3-dichloropropene	5	<1.0	< 1.0	< 1.0	< 1.0	< 1.0	< 1.0	< 1.0	< 1.0	< 1.0	<1.0	<1.0	< 1.0
Dibromochloromethane	5	<1.0	< 1.0	< 1.0	< 1.0	< 1.0	< 1.0	< 1.0	< 1.0	< 1.0	<1.0	<1.0	< 1.0
Ethylbenzene	5	<1.0	< 1.0	< 1.0	< 1.0	< 1.0	< 1.0	< 1.0	< 1.0	< 1.0	<1.0	<1.0	< 1.0
Methylene Chloride	5	<2.0	< 2.0	< 2.0	< 2.0	< 2.0	< 2.0	< 2.0	< 2.0	< 2.0	<2.0	<2.0	< 2.0
Styrene	5	<1.0	< 1.0	< 1.0	< 1.0	< 1.0	< 1.0	< 1.0	< 1.0	< 1.0	<1.0	<1.0	< 1.0
Tetrachloroethene	5	1.6	< 1.0	< 1.0	0.30 J	0.30 J	< 1.0	< 1.0	< 1.0	< 1.0	<1.0	<1.0	< 1.0
Toluene	5	<1.0	< 1.0	< 1.0	< 1.0	< 1.0	< 1.0	< 1.0	< 1.0	< 1.0	<1.0	<1.0	< 1.0
trans-1,2-dichloroethene	5	<1.0	< 1.0	< 1.0	< 1.0	< 1.0	< 1.0	< 1.0	< 1.0	< 1.0	<1.0	<1.0	< 1.0
trans-1,3-dichloropropene	5	<1.0	< 1.0	< 1.0	< 1.0	< 1.0	< 1.0	< 1.0	< 1.0	< 1.0	<1.0	<1.0	< 1.0
Trichloroethylene	5	0.71 J	11.1	9.5	2.1	.63 J	< 1.0	< 1.0	0.96 J	0.62 J	0.68 J	0.42 J	0.60 J
Trichlorotrifluoroethane (Freon 113)	5	<5.0	< 5.0	< 5.0	< 5.0	< 5.0	< 5.0	< 5.0	< 5.0	< 5.0	<5.0	<5.0	< 5.0
Vinyl Chloride	2	<1.0	< 1.0	< 1.0	< 1.0	< 1.0	< 1.0	< 1.0	< 1.0	< 1.0	<1.0	<1.0	< 1.0
Xylene-o	5	<1.0	< 1.0	< 1.0	< 1.0	< 1.0	< 1.0	< 1.0	< 1.0	< 1.0	<1.0	<1.0	< 1.0
Xylenes - m,p	5	<1.0	< 1.0	< 1.0	< 1.0	< 1.0	< 1.0	< 1.0	< 1.0	< 1.0	<1.0	<1.0	< 1.0
TVOCs		2.3	11	9.5	2.4	0.93	0	0	0.96	0.62	0.68	0.42	0.6

See Notes and Abbreviations on Last Page

Table 10
Concentrations of Volatile Organic Compounds in Groundwater
Samples Collected from Wells in the Shallow Zone ⁽¹⁾,
Operable Unit 2, Northrop Grumman Systems Corporation,
Bethpage, New York

Constituents units in (ug/L)	Well ID:	GM-74I	GM-78S	GM-78I	HN-40S	HN-40I	HN-42S	HN-42I	N-10631	N-10631	N-10631
	Sample ID:	GM-74I	GM-78S	GM-78I	HN-40S	HN-40I	HN-42S	HN-42I	N-10631	N-10631	REP111317DC1
	Sample Date:	10/25/2017	6/22/2017	5/5/2017	4/19/2017	4/19/2017	6/22/2017	4/19/2017	6/23/2017	11/13/2017	11/13/2017
	NYSDEC SCGs (ug/L) ⁽²⁾										
1,1,1-Trichloroethane	5	< 1.0	<1.0	< 1.0	< 1.0	< 1.0	< 1.0	< 1.0	< 1.0	< 1.0	< 1.0
1,1,2,2-Tetrachloroethane	5	< 1.0	<1.0	< 1.0	< 1.0	< 1.0	< 1.0	< 1.0	< 1.0	< 1.0	< 1.0
1,1,2-Trichloroethane	5	< 1.0	<1.0	< 1.0	< 1.0	< 1.0	< 1.0	< 1.0	< 1.0	< 1.0	< 1.0
1,1-Dichloroethane	5	< 1.0	<1.0	< 1.0	< 1.0	< 1.0	< 1.0	< 1.0	< 1.0	< 1.0	< 1.0
1,1-Dichloroethene	5	< 1.0	<1.0	< 1.0	< 1.0	< 1.0	< 1.0	< 1.0	< 1.0	< 1.0	< 1.0
1,2-Dichloroethane	5	< 1.0	<1.0	< 1.0	< 1.0	< 1.0	< 1.0	< 1.0	< 1.0	< 1.0	< 1.0
1,2-Dichloropropane	5	< 1.0	<1.0	< 1.0	< 1.0	< 1.0	< 1.0	< 1.0	< 1.0	< 1.0	< 1.0
2-Butanone	50	< 10	<10	< 10	< 10	< 10	< 10	< 10	< 10	< 10	< 10
2-Hexanone	50	< 5.0	<5.0	< 5.0	< 5.0	< 5.0	< 5.0	< 5.0	< 5.0	< 5.0	< 5.0
4-methyl-2-pentanone	50	< 5.0	<5.0	< 5.0	< 5.0	< 5.0	< 5.0	< 5.0	< 5.0	< 5.0	< 5.0
Acetone	50	< 10	<10	< 10	< 10	< 10	< 10	< 10	< 10	< 10	< 10
Benzene	1	< 0.50	<0.50	< 0.50	< 0.50	< 0.50	< 0.50	< 0.50	< 0.50	< 0.50	< 0.50
Bromodichloromethane	50	< 1.0	<1.0	< 1.0	< 1.0	< 1.0	< 1.0	< 1.0	< 1.0	< 1.0	< 1.0
Bromoform	50	< 1.0	<1.0	< 1.0	< 1.0	< 1.0	< 1.0	< 1.0	< 1.0	< 1.0	< 1.0
Bromomethane	5	< 2.0	<2.0	< 2.0	< 2.0	< 2.0	< 2.0	< 2.0	< 2.0	< 2.0	< 2.0
Carbon Disulfide	50	< 2.0	<2.0	< 2.0	< 2.0	< 2.0	< 2.0	< 2.0	< 2.0	< 2.0	< 2.0
Carbon tetrachloride	5	< 1.0	<1.0	< 1.0	< 1.0	< 1.0	< 1.0	< 1.0	< 1.0	< 1.0	< 1.0
Chlorobenzene	5	< 1.0	<1.0	< 1.0	< 1.0	< 1.0	< 1.0	< 1.0	< 1.0	< 1.0	< 1.0
Chloroethane	5	< 1.0	<1.0	< 1.0	< 1.0	< 1.0	< 1.0	< 1.0	< 1.0	< 1.0	< 1.0
Chloroform	7	< 1.0	<1.0	< 1.0	0.63 J	< 1.0	< 1.0	< 1.0	< 1.0	< 1.0	< 1.0
Chloromethane	5	< 1.0	<1.0	< 1.0	< 1.0	< 1.0	< 1.0	< 1.0	< 1.0	< 1.0	< 1.0
cis-1,2-dichloroethene	5	< 1.0	<1.0	< 1.0	< 1.0	< 1.0	< 1.0	< 1.0	< 1.0	< 1.0	< 1.0
cis-1,3-dichloropropene	5	< 1.0	<1.0	< 1.0	< 1.0	< 1.0	< 1.0	< 1.0	< 1.0	< 1.0	< 1.0
Dibromochloromethane	5	< 1.0	<1.0	< 1.0	< 1.0	< 1.0	< 1.0	< 1.0	< 1.0	< 1.0	< 1.0
Ethylbenzene	5	< 1.0	<1.0	< 1.0	< 1.0	< 1.0	< 1.0	< 1.0	< 1.0	< 1.0	< 1.0
Methylene Chloride	5	< 2.0	<2.0	< 2.0	< 2.0	< 2.0	< 2.0	< 2.0	< 2.0	< 2.0	< 2.0
Styrene	5	< 1.0	<1.0	< 1.0	< 1.0	< 1.0	< 1.0	< 1.0	< 1.0	< 1.0	< 1.0
Tetrachloroethene	5	< 1.0	<1.0	0.24 J	< 1.0	< 1.0	< 1.0	< 1.0	< 1.0	< 1.0	< 1.0
Toluene	5	< 1.0	<1.0	< 1.0	< 1.0	< 1.0	< 1.0	< 1.0	< 1.0	< 1.0	< 1.0
trans-1,2-dichloroethene	5	< 1.0	<1.0	< 1.0	< 1.0	< 1.0	< 1.0	< 1.0	< 1.0	< 1.0	< 1.0
trans-1,3-dichloropropene	5	< 1.0	<1.0	< 1.0	< 1.0	< 1.0	< 1.0	< 1.0	< 1.0	< 1.0	< 1.0
Trichloroethylene	5	1.1	0.43 J	0.44 J	< 1.0	< 1.0	< 1.0	0.42 J	1.3	1.2	1.2
Trichlorotrifluoroethane (Freon 113)	5	< 5.0	<5.0	< 5.0	< 5.0	< 5.0	< 5.0	< 5.0	< 5.0	< 5.0	< 5.0
Vinyl Chloride	2	< 1.0	<1.0	< 1.0	< 1.0	< 1.0	< 1.0	< 1.0	< 1.0	< 1.0	< 1.0
Xylene-o	5	< 1.0	<1.0	< 1.0	< 1.0	< 1.0	< 1.0	< 1.0	< 1.0	< 1.0	< 1.0
Xylenes - m,p	5	< 1.0	<1.0	< 1.0	< 1.0	< 1.0	< 1.0	< 1.0	< 1.0	< 1.0	< 1.0
TVOCs		1.1	0.43	0.68	0.63	0	0	0.42	1.3	1.2	1.2

See Notes and Abbreviations on Last Page

Table 10
Concentrations of Volatile Organic Compounds in Groundwater
Samples Collected from Wells in the Shallow Zone ⁽¹⁾,
Operable Unit 2, Northrop Grumman Systems Corporation,
Bethpage, New York

Notes and Abbreviations:

(1) Well identification (e.g., GM-151) does not necessarily designate the actual hydrogeologic zone.

Determination of the hydrogeologic zone is based on the well screen interval and the regional model layering.

(2) Standards, Criteria, and Guidance (SCG) values based on documents referenced in the Groundwater

Feasibility Study Report (ARCADIS Geraghty & Miller, Inc. 2000) that are based on the NYSDEC TOGs (NYSDEC 1998); most stringent values are listed.

Results for the program are validated at 20% frequency, per protocols specified in OU2 Groundwater Monitoring Plan (Arcadis 2016)

Samples analyzed for the TCL VOCs using USEPA Method 8260C.

TVOCs are rounded to two significant figures.

Bold value indicates a detection.

NYSDEC New York State Department of Environmental Conservation

USEPA United States Environmental Protection Agency

VOCs Volatile Organic Compounds

TVOCs Total Volatile Organic Compounds

REP Blind Duplicate Sample

SCG Standards, Criteria and Guidance Value

µg/L micrograms per Liter

J Value is estimated concentration

TCL Target Compound List

TOGs Technical and Operational Guidance Series

< 5.0 Compound not detected above its laboratory quantification limit.

 Compound detected in exceedance of NYSDEC SCG Criteria

OU2 Operable Unit 2

Table 11
Concentrations of Volatile Organic Compounds in
Groundwater Samples Collected from Wells
in the Intermediate Zone ⁽¹⁾, Operable Unit 2,
Northrop Grumman Systems Corporation,
Bethpage, New York

Constituents units in (ug/L)	Well ID: Sample ID: Sample Date:	GM-21I GM-21I 4/26/2017	HN-24I HN-24I 4/20/2017
	NYSDEC SCG (ug/L) ⁽²⁾		
1,1,1-Trichloroethane	5	< 1.0	0.45 J
1,1,2,2-Tetrachloroethane	5	< 1.0	< 1.0
1,1,2-Trichloroethane	5	< 1.0	< 1.0
1,1-Dichloroethane	5	< 1.0	1.1
1,1-Dichloroethene	5	< 1.0	3.7
1,2-Dichloroethane	5	< 1.0	< 1.0
1,2-Dichloropropane	5	< 1.0	< 1.0
2-Butanone	50	< 10	< 10
2-Hexanone	50	< 5.0	< 5.0
4-methyl-2-pentanone	50	< 5.0	< 5.0
Acetone	50	< 10	< 10
Benzene	1	< 0.50	< 0.50
Bromodichloromethane	50	< 1.0	< 1.0
Bromoform	50	< 1.0	< 1.0
Bromomethane	5	< 2.0	< 2.0
Carbon Disulfide	50	< 2.0	< 2.0
Carbon tetrachloride	5	< 1.0	< 1.0
Chlorobenzene	5	< 1.0	< 1.0
Chloroethane	5	< 1.0	< 1.0
Chloroform	7	< 1.0	0.60 J
Chloromethane	5	< 1.0	< 1.0
cis-1,2-dichloroethene	5	< 1.0	0.53 J
cis-1,3-dichloropropene	5	< 1.0	< 1.0
Dibromochloromethane	5	< 1.0	< 1.0
Ethylbenzene	5	< 1.0	< 1.0
Methylene Chloride	5	< 2.0	< 2.0
Styrene	5	< 1.0	< 1.0
Tetrachloroethene	5	< 1.0	15.0
Toluene	5	< 1.0	< 1.0
trans-1,2-dichloroethene	5	< 1.0	< 1.0
trans-1,3-dichloropropene	5	< 1.0	< 1.0
Trichloroethylene	5	0.67 J	11.2
Trichlorotrifluoroethane (Freon 113)	5	< 5.0	< 5.0
Vinyl Chloride	2	< 1.0	< 1.0
Xylene-o	5	< 1.0	< 1.0
Xylenes - m,p	5	< 1.0	< 1.0
TVOCs		0.67	33

See Notes and Abbreviations on Last Page

Table 11
Concentrations of Volatile Organic Compounds in
Groundwater Samples Collected from Wells
in the Intermediate Zone ⁽¹⁾, Operable Unit 2,
Northrop Grumman Systems Corporation,
Bethpage, New York

Notes and Abbreviations:

- (1) Well identification (e.g., GM-211) does not necessarily designate the actual hydrogeologic zone. Determination of the hydrogeologic zone is based on the well screen interval and the Standards, Criteria, and Guidance (SCG) values based on documents referenced in the Groundwater Feasibility Study Report (ARCADIS Geraghty & Miller, Inc. 2000) that are based on the NYSDEC TOGs (NYSDEC 1998); most stringent values are listed.
- (2)

Results for the Samples analyzed for the TCL VOCs using USEPA Method 8260C. TVOCs are rounded to two significant figures.

Bold value indicates a detection.

NYSDEC	New York State Department of Environmental Conservation
USEPA	United States Environmental Protection Agency
VOCs	Volatile Organic Compounds
TVOCs	Total Volatile Organic Compounds
SCG	Standards, Criteria and Guidance Value
µg/L	micrograms per Liter
J	Value is estimated concentration
TCL	Target Compound List
TOGs	Technical and Operational Guidance Series
< 5.0	Compound not detected above its laboratory quantification limit.
 	Compound detected in exceedance of NYSDEC SCG Criteria
OU2	Operable Unit 2

Table 12
Concentrations of Volatile Organic Compounds
in Groundwater Samples Collected from Wells
in the Deep Zone⁽¹⁾, Operable Unit 2,
Northrop Grumman Systems Corporation
Bethpage, New York.

Constituents units in (ug/L)	Well ID:	GM-13D	GM-15D	GM-15D	GM-17D
	Sample ID:	GM-13D	GM-15D	GM-15D	GM-17D
	Sample Date:	4/17/2017	6/28/2017	11/2/2017	5/2/2017
	NYSDEC SCGs ⁽²⁾				
1,1,1-Trichloroethane	5	0.74 J	< 1.0	< 1.0	< 1.0
1,1,2,2-Tetrachloroethane	5	< 1.0	< 1.0	< 1.0	< 1.0
1,1,2-Trichloroethane	5	< 1.0	< 1.0	< 1.0	< 1.0
1,1-Dichloroethane	5	4.4	< 1.0	< 1.0	< 1.0
1,1-Dichloroethene	5	3.5	< 1.0	< 1.0	< 1.0
1,2-Dichloroethane	5	< 1.0	< 1.0	< 1.0	< 1.0
1,2-Dichloropropane	5	< 1.0	< 1.0	< 1.0	< 1.0
2-Butanone	50	< 10	< 10	< 10	< 10
2-Hexanone	50	< 5.0	< 5.0	< 5.0	< 5.0
4-methyl-2-pentanone	50	< 5.0	< 5.0	< 5.0	< 5.0
Acetone	50	< 10	< 10	< 10	< 10
Benzene	1	< 0.50	< 0.50	< 0.50	< 0.50
Bromodichloromethane	50	< 1.0	< 1.0	< 1.0	< 1.0
Bromoform	50	< 1.0	< 1.0	< 1.0	< 1.0
Bromomethane	5	< 2.0	< 2.0	< 2.0	< 2.0
Carbon Disulfide	50	< 2.0	< 2.0	< 2.0	< 2.0
Carbon tetrachloride	5	< 1.0	< 1.0	< 1.0	< 1.0
Chlorobenzene	5	< 1.0	< 1.0	< 1.0	< 1.0
Chloroethane	5	< 1.0	< 1.0	< 1.0	< 1.0
Chloroform	7	< 1.0	< 1.0	< 1.0	< 1.0
Chloromethane	5	< 1.0	< 1.0	< 1.0	< 1.0
cis-1,2-dichloroethene	5	5.5	< 1.0	< 1.0	< 1.0
cis-1,3-dichloropropene	5	< 1.0	< 1.0	< 1.0	< 1.0
Dibromochloromethane	5	< 1.0	< 1.0	< 1.0	< 1.0
Ethylbenzene	5	< 1.0	< 1.0	< 1.0	< 1.0
Methylene Chloride	5	< 2.0	< 2.0	< 2.0	< 2.0
Styrene	5	< 1.0	< 1.0	< 1.0	< 1.0
Tetrachloroethene	5	45.6	< 1.0	< 1.0	< 1.0
Toluene	5	< 1.0	< 1.0	< 1.0	< 1.0
trans-1,2-dichloroethene	5	< 1.0	< 1.0	< 1.0	< 1.0
trans-1,3-dichloropropene	5	< 1.0	< 1.0	< 1.0	< 1.0
Trichloroethylene	5	23.0	< 1.0	0.33 J	0.83 J
Trichlorotrifluoroethane (Freon 113)	5	< 5.0	< 5.0	< 5.0	< 5.0
Vinyl Chloride	2	< 1.0	< 1.0	< 1.0	< 1.0
Xylene-o	5	< 1.0	< 1.0	< 1.0	< 1.0
Xylenes - m,p	5	< 1.0	< 1.0	< 1.0	< 1.0
TVOCs		83	0	0.33	0.83

See Notes and Abbreviations on last page.

Table 12
Concentrations of Volatile Organic Compounds
in Groundwater Samples Collected from Wells
in the Deep Zone⁽¹⁾, Operable Unit 2,
Northrop Grumman Systems Corporation
Bethpage, New York.

Constituents units in (ug/L)	Well ID:	GM-17D	GM-18D	GM-18D	GM-20D	GM-21D
	Sample ID:	GM-17D	GM-18D	GM-18D	GM-20D	GM-21D
	Sample Date:	11/1/2017	4/21/2017	10/31/2017	4/25/2017	5/3/2017
	NYSDEC SCGs ⁽²⁾					
1,1,1-Trichloroethane	5	< 1.0	< 1.0	< 1.0	< 1.0	< 1.0
1,1,2,2-Tetrachloroethane	5	< 1.0	< 1.0	< 1.0	< 1.0	< 1.0
1,1,2-Trichloroethane	5	< 1.0	< 1.0	< 1.0	< 1.0	< 1.0
1,1-Dichloroethane	5	< 1.0	< 1.0	< 1.0	< 1.0	< 1.0
1,1-Dichloroethene	5	< 1.0	< 1.0	< 1.0	< 1.0	< 1.0
1,2-Dichloroethane	5	< 1.0	< 1.0	< 1.0	< 1.0	< 1.0
1,2-Dichloropropane	5	< 1.0	< 1.0	< 1.0	< 1.0	< 1.0
2-Butanone	50	< 10	< 10	< 10	< 10	< 10
2-Hexanone	50	< 5.0	< 5.0	< 5.0	< 5.0	< 5.0
4-methyl-2-pentanone	50	< 5.0	< 5.0	< 5.0	< 5.0	< 5.0
Acetone	50	< 10	< 10	< 10	< 10	< 10
Benzene	1	< 0.50	< 0.50	< 0.50	< 0.50	< 0.50
Bromodichloromethane	50	< 1.0	< 1.0	< 1.0	< 1.0	< 1.0
Bromoform	50	< 1.0	< 1.0	< 1.0	< 1.0	< 1.0
Bromomethane	5	< 2.0	< 2.0	< 2.0	< 2.0	< 2.0
Carbon Disulfide	50	< 2.0	< 2.0	< 2.0	< 2.0	< 2.0
Carbon tetrachloride	5	< 1.0	< 1.0	< 1.0	< 1.0	< 1.0
Chlorobenzene	5	< 1.0	< 1.0	< 1.0	< 1.0	< 1.0
Chloroethane	5	< 1.0	< 1.0	< 1.0	< 1.0	< 1.0
Chloroform	7	< 1.0	< 1.0	< 1.0	< 1.0	< 1.0
Chloromethane	5	< 1.0	< 1.0	< 1.0	< 1.0	< 1.0
cis-1,2-dichloroethene	5	< 1.0	< 1.0	< 1.0	< 1.0	< 1.0
cis-1,3-dichloropropene	5	< 1.0	< 1.0	< 1.0	< 1.0	< 1.0
Dibromochloromethane	5	< 1.0	< 1.0	< 1.0	< 1.0	< 1.0
Ethylbenzene	5	< 1.0	< 1.0	< 1.0	< 1.0	< 1.0
Methylene Chloride	5	< 2.0	< 2.0	< 2.0	< 2.0	< 2.0
Styrene	5	< 1.0	< 1.0	< 1.0	< 1.0	< 1.0
Tetrachloroethene	5	< 1.0	< 1.0	< 1.0	< 1.0	< 1.0
Toluene	5	< 1.0	< 1.0	< 1.0	< 1.0	< 1.0
trans-1,2-dichloroethene	5	< 1.0	< 1.0	< 1.0	< 1.0	< 1.0
trans-1,3-dichloropropene	5	< 1.0	< 1.0	< 1.0	< 1.0	< 1.0
Trichloroethylene	5	0.5 J	0.52 J	0.63 J	1.0	1.5
Trichlorotrifluoroethane (Freon 113)	5	< 5.0	< 5.0	< 5.0	< 5.0	< 5.0
Vinyl Chloride	2	< 1.0	< 1.0	< 1.0	< 1.0	< 1.0
Xylene-o	5	< 1.0	< 1.0	< 1.0	< 1.0	< 1.0
Xylenes - m,p	5	< 1.0	< 1.0	< 1.0	< 1.0	< 1.0
TVOCs		0.50	0.52	0.63	1.0	1.5

See Notes and Abbreviations on last page.

Table 12
Concentrations of Volatile Organic Compounds
in Groundwater Samples Collected from Wells
in the Deep Zone⁽¹⁾, Operable Unit 2,
Northrop Grumman Systems Corporation
Bethpage, New York.

Constituents units in (ug/L)	Well ID:	GM-36D	GM-37D	GM-38D	GM-38D	GM-39DA
	Sample ID:	GM-36D	GM-37D	GM-38D	GM-38D	GM-39DA
	Sample Date:	6/19/2017	7/11/2017	5/1/2017	10/24/2017	5/3/2017
	NYSDEC SCGs ⁽²⁾					
1,1,1-Trichloroethane	5	< 1.0	< 1.0	0.36 J	0.32 J	< 1.0
1,1,2,2-Tetrachloroethane	5	< 1.0	< 1.0	< 1.0	< 1.0	< 1.0
1,1,2-Trichloroethane	5	< 1.0	< 1.0	< 1.0	< 1.0	< 1.0
1,1-Dichloroethane	5	< 1.0	0.29 J	0.64 J	0.50 J	< 1.0
1,1-Dichloroethene	5	< 1.0	< 1.0	0.69 J	0.65 J	< 1.0
1,2-Dichloroethane	5	< 1.0	< 1.0	0.44 J	< 1.0	< 1.0
1,2-Dichloropropane	5	< 1.0	< 1.0	< 1.0	< 1.0	< 1.0
2-Butanone	50	< 10	< 10	< 10	< 10	< 10
2-Hexanone	50	< 5.0	< 5.0	< 5.0	< 5.0	< 5.0
4-methyl-2-pentanone	50	< 5.0	< 5.0	< 5.0	< 5.0	< 5.0
Acetone	50	< 10	< 10	< 10	< 10	< 10
Benzene	1	< 0.50	< 0.50	< 0.50	< 0.50	< 0.50
Bromodichloromethane	50	< 1.0	< 1.0	< 1.0	< 1.0	< 1.0
Bromoform	50	< 1.0	< 1.0	< 1.0	< 1.0	< 1.0
Bromomethane	5	< 2.0	< 2.0	< 2.0	< 2.0	< 2.0
Carbon Disulfide	50	< 2.0	< 2.0	< 2.0	< 2.0	< 2.0
Carbon tetrachloride	5	< 1.0	< 1.0	< 1.0	< 1.0	< 1.0
Chlorobenzene	5	< 1.0	< 1.0	< 1.0	< 1.0	< 1.0
Chloroethane	5	< 1.0	< 1.0	< 1.0	< 1.0	< 1.0
Chloroform	7	< 1.0	< 1.0	< 1.0	< 1.0	< 1.0
Chloromethane	5	< 1.0	< 1.0	< 1.0	< 1.0	< 1.0
cis-1,2-dichloroethene	5	< 1.0	< 1.0	0.54 J	< 1.0	< 1.0
cis-1,3-dichloropropene	5	< 1.0	< 1.0	< 1.0	< 1.0	< 1.0
Dibromochloromethane	5	< 1.0	< 1.0	< 1.0	< 1.0	< 1.0
Ethylbenzene	5	< 1.0	< 1.0	< 1.0	< 1.0	< 1.0
Methylene Chloride	5	< 2.0	< 2.0	< 2.0	< 2.0	< 2.0
Styrene	5	< 1.0	< 1.0	< 1.0	< 1.0	< 1.0
Tetrachloroethene	5	< 1.0	< 1.0	5.8	5	< 1.0
Toluene	5	< 1.0	< 1.0	< 1.0	< 1.0	< 1.0
trans-1,2-dichloroethene	5	< 1.0	< 1.0	< 1.0	< 1.0	< 1.0
trans-1,3-dichloropropene	5	< 1.0	< 1.0	< 1.0	< 1.0	< 1.0
Trichloroethylene	5	< 1.0	8.0	85.7	89	1.6
Trichlorotrifluoroethane (Freon 113)	5	< 5.0	< 5.0	< 5.0	< 1.0	< 5.0
Vinyl Chloride	2	< 1.0	< 1.0	< 1.0	< 1.0	< 1.0
Xylene-o	5	< 1.0	< 1.0	< 1.0	< 1.0	< 1.0
Xylenes - m,p	5	< 1.0	< 1.0	< 1.0	< 1.0	< 1.0
TVOCs		0	8.3	94	96	1.6

See Notes and Abbreviations on last page.

Table 12
Concentrations of Volatile Organic Compounds
in Groundwater Samples Collected from Wells
in the Deep Zone⁽¹⁾, Operable Unit 2,
Northrop Grumman Systems Corporation
Bethpage, New York.

Constituents units in (ug/L)	Well ID:	GM-39DA	GM-70D2	GM-74D	GM-74D	GM-79I
	Sample ID:	GM-39DA	GM-70D2	GM-74D	GM-74D	GM-79I
	Sample Date:	11/1/2017	4/24/2017	5/2/2017	10/25/2017	6/28/2017
	NYSDEC SCGs ⁽²⁾					
1,1,1-Trichloroethane	5	< 1.0	< 1.0	< 1.0	< 1.0	< 1.0
1,1,2,2-Tetrachloroethane	5	< 1.0	< 1.0	< 1.0	< 1.0	< 1.0
1,1,2-Trichloroethane	5	< 1.0	< 1.0	< 1.0	< 1.0	< 1.0
1,1-Dichloroethane	5	< 1.0	< 1.0	< 1.0	< 1.0	< 1.0
1,1-Dichloroethene	5	< 1.0	< 1.0	< 1.0	< 1.0	< 1.0
1,2-Dichloroethane	5	< 1.0	< 1.0	< 1.0	< 1.0	< 1.0
1,2-Dichloropropane	5	< 1.0	< 1.0	< 1.0	< 1.0	< 1.0
2-Butanone	50	< 10	< 10	< 10	< 10	< 10
2-Hexanone	50	< 5.0	< 5.0	< 5.0	< 5.0	< 5.0
4-methyl-2-pentanone	50	< 5.0	< 5.0	< 5.0	< 5.0	< 5.0
Acetone	50	< 10	< 10	< 10	< 10	< 10
Benzene	1	< 0.50	< 0.50	< 0.50	< 0.50	< 0.50
Bromodichloromethane	50	< 1.0	< 1.0	< 1.0	< 1.0	< 1.0
Bromoform	50	< 1.0	< 1.0	< 1.0	< 1.0	< 1.0
Bromomethane	5	< 2.0	< 2.0	< 2.0	< 2.0	< 2.0
Carbon Disulfide	50	< 2.0	< 2.0	< 2.0	< 2.0	< 2.0
Carbon tetrachloride	5	< 1.0	< 1.0	< 1.0	< 1.0	< 1.0
Chlorobenzene	5	< 1.0	< 1.0	< 1.0	< 1.0	< 1.0
Chloroethane	5	< 1.0	< 1.0	< 1.0	< 1.0	< 1.0
Chloroform	7	< 1.0	< 1.0	< 1.0	< 1.0	< 1.0
Chloromethane	5	< 1.0	< 1.0	< 1.0	< 1.0	< 1.0
cis-1,2-dichloroethene	5	< 1.0	< 1.0	< 1.0	< 1.0	< 1.0
cis-1,3-dichloropropene	5	< 1.0	< 1.0	< 1.0	< 1.0	< 1.0
Dibromochloromethane	5	< 1.0	< 1.0	< 1.0	< 1.0	< 1.0
Ethylbenzene	5	< 1.0	< 1.0	< 1.0	< 1.0	< 1.0
Methylene Chloride	5	< 2.0	< 2.0	< 2.0	< 2.0	< 2.0
Styrene	5	< 1.0	< 1.0	< 1.0	< 1.0	< 1.0
Tetrachloroethene	5	< 1.0	2.4	< 1.0	< 1.0	< 1.0
Toluene	5	< 1.0	< 1.0	< 1.0	< 1.0	< 1.0
trans-1,2-dichloroethene	5	< 1.0	< 1.0	< 1.0	< 1.0	< 1.0
trans-1,3-dichloropropene	5	< 1.0	< 1.0	< 1.0	< 1.0	< 1.0
Trichloroethylene	5	1.1	7.8	1.3	1.5	0.45 J
Trichlorotrifluoroethane (Freon 113)	5	< 5.0	< 5.0	< 5.0	< 5.0	< 5.0
Vinyl Chloride	2	< 1.0	< 1.0	< 1.0	< 1.0	< 1.0
Xylene-o	5	< 1.0	< 1.0	< 1.0	< 1.0	< 1.0
Xylenes - m,p	5	< 1.0	< 1.0	< 1.0	< 1.0	< 1.0
TVOCs		1.1	10	1.3	1.5	0.45

See Notes and Abbreviations on last page.

Table 12
Concentrations of Volatile Organic Compounds
in Groundwater Samples Collected from Wells
in the Deep Zone⁽¹⁾, Operable Unit 2,
Northrop Grumman Systems Corporation
Bethpage, New York.

Constituents units in (ug/L)	Well ID:	GM-79I	GM-79D	GM-79D	N-10624	N-10627
	Sample ID:	GM-79I	GM-79D	GM-79D	N-10624	N-10627
	Sample Date:	10/30/2017	6/28/2017	10/30/2017	6/21/2017	6/21/2017
	NYSDEC SCGs ⁽²⁾					
1,1,1-Trichloroethane	5	< 1.0	< 1.0	< 1.0	< 1.0	< 1.0
1,1,2,2-Tetrachloroethane	5	< 1.0	< 1.0	< 1.0	< 1.0	< 1.0
1,1,2-Trichloroethane	5	< 1.0	< 1.0	< 1.0	< 1.0	< 1.0
1,1-Dichloroethane	5	< 1.0	< 1.0	< 1.0	< 1.0	< 1.0
1,1-Dichloroethene	5	< 1.0	< 1.0	< 1.0	< 1.0	< 1.0
1,2-Dichloroethane	5	< 1.0	< 1.0	< 1.0	< 1.0	< 1.0
1,2-Dichloropropane	5	< 1.0	< 1.0	< 1.0	< 1.0	< 1.0
2-Butanone	50	< 10	< 10	< 10	< 10	< 10
2-Hexanone	50	< 5.0	< 5.0	< 5.0	< 5.0	< 5.0
4-methyl-2-pentanone	50	< 5.0	< 5.0	< 5.0	< 5.0	< 5.0
Acetone	50	< 10	< 10	< 10	< 10	< 10
Benzene	1	< 0.50	< 0.50	< 0.50	< 0.50	< 0.50
Bromodichloromethane	50	< 1.0	< 1.0	< 1.0	< 1.0	< 1.0
Bromoform	50	< 1.0	< 1.0	< 1.0	< 1.0	< 1.0
Bromomethane	5	< 2.0	< 2.0	< 2.0	< 2.0	< 2.0
Carbon Disulfide	50	< 2.0	< 2.0	< 2.0	< 2.0	< 2.0
Carbon tetrachloride	5	< 1.0	< 1.0	< 1.0	< 1.0	< 1.0
Chlorobenzene	5	< 1.0	< 1.0	< 1.0	< 1.0	< 1.0
Chloroethane	5	< 1.0	< 1.0	< 1.0	< 1.0	< 1.0
Chloroform	7	< 1.0	< 1.0	< 1.0	< 1.0	< 1.0
Chloromethane	5	< 1.0	< 1.0	< 1.0	< 1.0	< 1.0
cis-1,2-dichloroethene	5	< 1.0	0.96 J	0.85 J	< 1.0	< 1.0
cis-1,3-dichloropropene	5	< 1.0	< 1.0	< 1.0	< 1.0	< 1.0
Dibromochloromethane	5	< 1.0	< 1.0	< 1.0	< 1.0	< 1.0
Ethylbenzene	5	< 1.0	< 1.0	< 1.0	< 1.0	< 1.0
Methylene Chloride	5	< 2.0	< 2.0	< 2.0	< 2.0	< 2.0
Styrene	5	< 1.0	< 1.0	< 1.0	< 1.0	< 1.0
Tetrachloroethene	5	< 1.0	< 1.0	< 1.0	< 1.0	< 1.0
Toluene	5	< 1.0	< 1.0	< 1.0	< 1.0	< 1.0
trans-1,2-dichloroethene	5	< 1.0	< 1.0	< 1.0	< 1.0	< 1.0
trans-1,3-dichloropropene	5	< 1.0	< 1.0	< 1.0	< 1.0	< 1.0
Trichloroethylene	5	0.39 J	46.9	45.2	0.33 J	0.31 J
Trichlorotrifluoroethane (Freon 113)	5	< 5.0	< 5.0	< 5.0	< 5.0	< 5.0
Vinyl Chloride	2	< 1.0	< 1.0	< 1.0	< 1.0	< 1.0
Xylene-o	5	< 1.0	< 1.0	< 1.0	< 1.0	< 1.0
Xylenes - m,p	5	< 1.0	< 1.0	< 1.0	< 1.0	< 1.0
TVOCs		0.39	48	46	0.33	0.31

See Notes and Abbreviations on last page.

Table 12
Concentrations of Volatile Organic Compounds
in Groundwater Samples Collected from Wells
in the Deep Zone⁽¹⁾, Operable Unit 2,
Northrop Grumman Systems Corporation
Bethpage, New York.

Notes and Abbreviations:

- (1) Well identification (e.g., GM-70D2) does not necessarily designate the actual hydrogeologic zone. Determination of the hydrogeologic zone is based on the well screen interval and the regional model layering.
- (2) Standards, Criteria, and Guidance (SCG) values based on documents referenced in the Groundwater Feasibility Study Report (ARCADIS Geraghty & Miller, Inc. 2000) that are based on the NYSDEC TOGs (NYSDEC 1998); most stringent values are listed.

Results for the program are validated at 20% frequency, per protocols specified in OU2 Groundwater Monitoring Plan (Arcadis 2016)

Samples analyzed for the TCL VOCs using USEPA Method 8260C.

TVOCs are rounded to two significant figures.

Bold value indicates a detection.

NYSDEC New York State Department of Environmental Conservation

USEPA United States Environmental Protection Agency

VOCs Volatile Organic Compounds

TVOCs Total Volatile Organic Compounds

µg/L micrograms per liter

SCG Standards, Criteria and Guidance Value

J Value is estimated concentration.

OU2 Operable Unit 2

TCL Target Compound List

TOGs Technical and Operational Guidance Series

< 5.0 Compound not detected above its laboratory quantification limit.

 Compound detected in exceedance of NYSDEC SCG Criteria

REP Blind duplicate sample

Table 13
Concentrations of Volatile Organic Compounds in
Groundwater Samples Collected from Wells
in the Deep 2 Zone⁽¹⁾, Operable Unit 2,
Northrop Grumman Systems Corporation
Bethpage, New York.

Constituents units in (ug/L)	Well ID:	GM-15D2	GM-15D2	GM-21D2	GM-21D2	GM-33D2
	Sample ID:	GM-15D2	GM-15D2	GM-21D2	GM-21D2	GM-33D2
	Sample Date:	6/28/2017	11/2/2017	5/19/2017	10/26/2017	6/12/2017
	NYSDEC SCGs ⁽²⁾					
1,1,1-Trichloroethane	5	< 1.0	< 1.0	< 1.0	< 1.0	< 1.0
1,1,2,2-Tetrachloroethane	5	< 1.0	< 1.0	< 1.0	< 1.0	< 1.0
1,1,2-Trichloroethane	5	< 1.0	< 1.0	< 1.0	< 1.0	< 1.0
1,1-Dichloroethane	5	0.37 J	0.35 J	0.22 J	< 1.0	< 1.0
1,1-Dichloroethene	5	0.95 J	0.72 J	0.58 J	< 1.0	< 1.0
1,2-Dichloroethane	5	< 1.0	< 1.0	< 1.0	< 1.0	< 1.0
1,2-Dichloropropane	5	< 1.0	< 1.0	< 1.0	< 1.0	< 1.0
2-Butanone	50	< 10	< 10	< 10	< 10	< 10
2-Hexanone	50	< 5.0	< 5.0	< 5.0	< 5.0	< 5.0
4-methyl-2-pentanone	50	< 5.0	< 5.0	< 5.0	< 5.0	< 5.0
Acetone	50	< 10	< 10	< 10	< 10	< 10
Benzene	1	< 0.50	< 0.50	< 0.50	< 0.50	< 0.50
Bromodichloromethane	50	< 1.0	< 1.0	< 1.0	< 1.0	< 1.0
Bromoform	50	< 1.0	< 1.0	< 1.0	< 1.0	< 1.0
Bromomethane	5	< 2.0	< 2.0	< 2.0	< 2.0	< 2.0
Carbon Disulfide	50	< 2.0	< 2.0	< 2.0	< 2.0	< 2.0
Carbon tetrachloride	5	< 1.0	< 1.0	< 1.0	< 1.0	< 1.0
Chlorobenzene	5	< 1.0	< 1.0	< 1.0	< 1.0	< 1.0
Chloroethane	5	< 1.0	< 1.0	< 1.0	< 1.0	< 1.0
Chloroform	7	< 1.0	< 1.0	< 1.0	< 1.0	< 1.0
Chloromethane	5	< 1.0	< 1.0	< 1.0	< 1.0	< 1.0
cis-1,2-dichloroethene	5	< 1.0	< 1.0	0.62 J	< 1.0	< 1.0
cis-1,3-dichloropropene	5	< 1.0	< 1.0	< 1.0	< 1.0	< 1.0
Dibromochloromethane	5	< 1.0	< 1.0	< 1.0	< 1.0	< 1.0
Ethylbenzene	5	< 1.0	< 1.0	< 1.0	< 1.0	< 1.0
Methylene Chloride	5	< 2.0	< 2.0	< 2.0	< 2.0	< 2.0
Styrene	5	< 1.0	< 1.0	< 1.0	< 1.0	< 1.0
Tetrachloroethene	5	6.2	4.4	4.0	3.9	3.8
Toluene	5	< 1.0	< 1.0	< 1.0	< 1.0	< 1.0
trans-1,2-dichloroethene	5	< 1.0	< 1.0	< 1.0	< 1.0	< 1.0
trans-1,3-dichloropropene	5	< 1.0	< 1.0	< 1.0	< 1.0	< 1.0
Trichloroethylene	5	10	8.1	21.0	16.1	16.3
Trichlorotrifluoroethane (Freon 113)	5	< 5.0	< 5.0	< 5.0	< 5.0	6.4
Vinyl Chloride	2	< 1.0	< 1.0	< 1.0	< 1.0	< 1.0
Xylene-o	5	< 1.0	< 1.0	< 1.0	< 1.0	< 1.0
Xylenes - m,p	5	< 1.0	< 1.0	< 1.0	< 1.0	< 1.0
TVOCs		18	14	26	20	27

See Notes and Abbreviations on last page.

Table 13
Concentrations of Volatile Organic Compounds in
Groundwater Samples Collected from Wells
in the Deep 2 Zone⁽¹⁾, Operable Unit 2,
Northrop Grumman Systems Corporation
Bethpage, New York.

Constituents units in (ug/L)	Well ID:	GM-33D2	GM-34D	GM-34D	GM-34D2	GM-34D2
	Sample ID:	GM-33D2	GM-34D	GM-34D	GM-34D2	GM-34D2
	Sample Date:	10/19/2017	6/26/2017	10/31/2017	6/26/2017	10/31/2017
	NYSDEC SCGs ⁽²⁾					
1,1,1-Trichloroethane	5	< 1.0	< 1.0	< 1.0	< 1.0	< 1.0
1,1,2,2-Tetrachloroethane	5	< 1.0	< 1.0	< 1.0	< 1.0	< 1.0
1,1,2-Trichloroethane	5	< 1.0	< 1.0	< 1.0	< 1.0	< 1.0
1,1-Dichloroethane	5	< 1.0	0.51 J	0.53 J	< 1.0	< 1.0
1,1-Dichloroethene	5	< 1.0	2.2	2.0	0.73 J	0.48 J
1,2-Dichloroethane	5	< 1.0	< 1.0	< 1.0	< 1.0	< 1.0
1,2-Dichloropropane	5	< 1.0	< 1.0	< 1.0	< 1.0	< 1.0
2-Butanone	50	< 10	< 10	< 10	< 10	< 10
2-Hexanone	50	< 5.0	< 5.0	< 5.0	< 5.0	< 5.0
4-methyl-2-pentanone	50	< 5.0	< 5.0	< 5.0	< 5.0	< 5.0
Acetone	50	< 10	< 10	< 10	< 10	< 10
Benzene	1	< 0.50	< 0.50	< 0.50	< 0.50	< 0.50
Bromodichloromethane	50	< 1.0	< 1.0	< 1.0	< 1.0	< 1.0
Bromoform	50	< 1.0	< 1.0	< 1.0	< 1.0	< 1.0
Bromomethane	5	< 2.0	< 2.0	< 2.0	< 2.0	< 2.0
Carbon Disulfide	50	< 2.0	< 2.0	< 2.0	< 2.0	< 2.0
Carbon tetrachloride	5	< 1.0	< 1.0	< 1.0	< 1.0	< 1.0
Chlorobenzene	5	< 1.0	< 1.0	< 1.0	< 1.0	< 1.0
Chloroethane	5	< 1.0	< 1.0	< 1.0	< 1.0	< 1.0
Chloroform	7	< 1.0	0.42 J	0.35 J	< 1.0	< 1.0
Chloromethane	5	< 1.0	< 1.0	< 1.0	< 1.0	< 1.0
cis-1,2-dichloroethene	5	< 1.0	8.8	7.2	1.8	2.2
cis-1,3-dichloropropene	5	< 1.0	< 1.0	< 1.0	< 1.0	< 1.0
Dibromochloromethane	5	< 1.0	< 1.0	< 1.0	< 1.0	< 1.0
Ethylbenzene	5	< 1.0	< 1.0	< 1.0	< 1.0	< 1.0
Methylene Chloride	5	< 2.0	< 2.0	< 2.0	< 2.0	< 2.0
Styrene	5	< 1.0	< 1.0	< 1.0	< 1.0	< 1.0
Tetrachloroethene	5	3.8	7.7	8.5	6.6	4.2
Toluene	5	< 1.0	< 1.0	< 1.0	< 1.0	< 1.0
trans-1,2-dichloroethene	5	< 1.0	< 1.0	< 1.0	< 1.0	0.80 J
trans-1,3-dichloropropene	5	< 1.0	< 1.0	< 1.0	< 1.0	< 1.0
Trichloroethylene	5	18.7	299	286 D	110	68.3
Trichlorotrifluoroethane (Freon 113)	5	6.9	2.1 J	3.7	< 5.0	< 5.0
Vinyl Chloride	2	< 1.0	< 1.0	< 1.0	< 1.0	< 1.0
Xylene-o	5	< 1.0	< 1.0	< 1.0	< 1.0	< 1.0
Xylenes - m,p	5	< 1.0	< 1.0	< 1.0	< 1.0	< 1.0
TVOCs		29	320	310	120	76

See Notes and Abbreviations on last page.

Table 13
Concentrations of Volatile Organic Compounds in
Groundwater Samples Collected from Wells
in the Deep 2 Zone⁽¹⁾, Operable Unit 2,
Northrop Grumman Systems Corporation
Bethpage, New York.

Constituents units in (ug/L)	Well ID:	GM-35D2	GM-35D2	GM-36D2	GM-37D2	GM-38D2
	Sample ID:	GM-35D2	GM-35D2	GM-36D2	GM-37D2	GM-38D2
	Sample Date:	4/24/2017	10/30/2017	6/19/2017	7/5/2017	5/2/2017
	NYSDEC SCGs ⁽²⁾					
1,1,1-Trichloroethane	5	< 1.0	< 1.0	0.45 J	0.45 J	0.96 J
1,1,2,2-Tetrachloroethane	5	< 1.0	< 1.0	< 1.0	< 1.0	< 1.0
1,1,2-Trichloroethane	5	< 1.0	< 1.0	< 1.0	< 1.0	0.38 J
1,1-Dichloroethane	5	< 1.0	< 1.0	0.92 J	1.5	1.8
1,1-Dichloroethene	5	< 1.0	< 1.0	0.89 J	< 1.0	1.8
1,2-Dichloroethane	5	< 1.0	< 1.0	< 1.0	< 1.0	< 1.0
1,2-Dichloropropane	5	< 1.0	< 1.0	< 1.0	< 1.0	< 1.0
2-Butanone	50	< 10	< 10	< 10	< 10	< 10
2-Hexanone	50	< 5.0	< 5.0	< 5.0	< 5.0	< 5.0
4-methyl-2-pentanone	50	< 5.0	< 5.0	< 5.0	< 5.0	< 5.0
Acetone	50	< 10	< 10	< 10	< 10	< 10
Benzene	1	< 0.50	< 0.50	< 0.50	< 0.50	< 0.50
Bromodichloromethane	50	< 1.0	< 1.0	< 1.0	< 1.0	< 1.0
Bromoform	50	< 1.0	< 1.0	< 1.0	< 1.0	< 1.0
Bromomethane	5	< 2.0	< 2.0	< 2.0	< 2.0	< 2.0
Carbon Disulfide	50	< 2.0	< 2.0	< 2.0	< 2.0	< 2.0
Carbon tetrachloride	5	< 1.0	< 1.0	< 1.0	< 1.0	< 1.0
Chlorobenzene	5	< 1.0	< 1.0	< 1.0	< 1.0	< 1.0
Chloroethane	5	< 1.0	< 1.0	< 1.0	< 1.0	< 1.0
Chloroform	7	< 1.0	< 1.0	< 1.0	< 1.0	0.35 J
Chloromethane	5	< 1.0	< 1.0	< 1.0	< 1.0	< 1.0
cis-1,2-dichloroethene	5	< 1.0	< 1.0	< 1.0	< 1.0	2.4
cis-1,3-dichloropropene	5	< 1.0	< 1.0	< 1.0	< 1.0	< 1.0
Dibromochloromethane	5	< 1.0	< 1.0	< 1.0	< 1.0	< 1.0
Ethylbenzene	5	< 1.0	< 1.0	< 1.0	< 1.0	< 1.0
Methylene Chloride	5	< 2.0	< 2.0	< 2.0	< 2.0	< 2.0
Styrene	5	< 1.0	< 1.0	< 1.0	< 1.0	< 1.0
Tetrachloroethene	5	6.0	5.1	< 1.0	< 1.0	< 1.0
Toluene	5	< 1.0	< 1.0	< 1.0	< 1.0	< 1.0
trans-1,2-dichloroethene	5	< 1.0	< 1.0	< 1.0	< 1.0	< 1.0
trans-1,3-dichloropropene	5	< 1.0	< 1.0	< 1.0	< 1.0	< 1.0
Trichloroethylene	5	38.4	33.7	3.0	1.6	306 D
Trichlorotrifluoroethane (Freon 113)	5	< 5.0	< 5.0	< 5.0	< 5.0	1.4 J
Vinyl Chloride	2	< 1.0	< 1.0	< 1.0	< 1.0	< 1.0
Xylene-o	5	< 1.0	< 1.0	< 1.0	< 1.0	< 1.0
Xylenes - m,p	5	< 1.0	< 1.0	< 1.0	< 1.0	< 1.0
TVOCs		44	39	5.3	3.6	320

See Notes and Abbreviations on last page.

Table 13
Concentrations of Volatile Organic Compounds in
Groundwater Samples Collected from Wells
in the Deep 2 Zone⁽¹⁾, Operable Unit 2,
Northrop Grumman Systems Corporation
Bethpage, New York.

Constituents units in (ug/L)	Well ID:	GM-38D2	GM-39DB	GM-39DB	GM-71D2
	Sample ID:	GM38D2	GM-39DB	GM-39DB	GM-71D2
	Sample Date:	10/24/2017	5/3/2017	11/1/2017	4/26/2017
	NYSDEC SCGs ⁽²⁾				
1,1,1-Trichloroethane	5	0.83 J	< 1.0	< 1.0	1.7
1,1,2,2-Tetrachloroethane	5	< 1.0	< 1.0	< 1.0	< 1.0
1,1,2-Trichloroethane	5	< 1.0	< 1.0	< 1.0	< 1.0
1,1-Dichloroethane	5	1.6	< 1.0	< 1.0	5.3
1,1-Dichloroethene	5	1.8	< 1.0	< 1.0	2.9
1,2-Dichloroethane	5	< 1.0	< 1.0	< 1.0	< 1.0
1,2-Dichloropropane	5	< 1.0	< 1.0	< 1.0	< 1.0
2-Butanone	50	< 10	< 10	< 10	< 10
2-Hexanone	50	< 5.0	< 5.0	< 5.0	< 5.0
4-methyl-2-pentanone	50	< 5.0	< 5.0	< 5.0	< 5.0
Acetone	50	< 10	< 10	< 10	< 10
Benzene	1	< 0.50	< 0.50	< 0.50	< 0.50
Bromodichloromethane	50	< 1.0	< 1.0	< 1.0	< 1.0
Bromoform	50	< 1.0	< 1.0	< 1.0	< 1.0
Bromomethane	5	< 2.0	< 2.0	< 2.0	< 2.0
Carbon Disulfide	50	< 2.0	< 2.0	< 2.0	< 2.0
Carbon tetrachloride	5	< 1.0	< 1.0	< 1.0	< 1.0
Chlorobenzene	5	< 1.0	< 1.0	< 1.0	< 1.0
Chloroethane	5	< 1.0	< 1.0	< 1.0	< 1.0
Chloroform	7	0.30 J	< 1.0	< 1.0	0.49 J
Chloromethane	5	< 1.0	< 1.0	< 1.0	< 1.0
cis-1,2-dichloroethene	5	2.0	< 1.0	< 1.0	0.61 J
cis-1,3-dichloropropene	5	< 1.0	< 1.0	< 1.0	< 1.0
Dibromochloromethane	5	< 1.0	< 1.0	< 1.0	< 1.0
Ethylbenzene	5	< 1.0	< 1.0	< 1.0	< 1.0
Methylene Chloride	5	< 2.0	< 2.0	< 2.0	< 2.0
Styrene	5	< 1.0	< 1.0	< 1.0	< 1.0
Tetrachloroethene	5	< 1.0	< 1.0	< 1.0	< 1.0
Toluene	5	< 1.0	< 1.0	< 1.0	< 1.0
trans-1,2-dichloroethene	5	< 1.0	< 1.0	< 1.0	< 1.0
trans-1,3-dichloropropene	5	< 1.0	< 1.0	< 1.0	< 1.0
Trichloroethylene	5	297 D	34.0	64.5	12.1
Trichlorotrifluoroethane (Freon 113)	5	< 5.0	< 5.0	< 5.0	< 5.0
Vinyl Chloride	2	< 1.0	< 1.0	< 1.0	< 1.0
Xylene-o	5	< 1.0	< 1.0	< 1.0	< 1.0
Xylenes - m,p	5	< 1.0	< 1.0	< 1.0	< 1.0
TVOCs		300	34	65	23

See Notes and Abbreviations on last page.

Table 13
Concentrations of Volatile Organic Compounds in
Groundwater Samples Collected from Wells
in the Deep 2 Zone⁽¹⁾, Operable Unit 2,
Northrop Grumman Systems Corporation
Bethpage, New York.

Constituents units in (ug/L)	Well ID:	GM-73D	GM-73D	GM-73D2	GM-73D2	GM-74D2	GM-74D2
	Sample ID:	GM-73D	GM-73D	GM-73D2	GM-73D2	GM-74D2	GM-74D2
	Sample Date:	6/15/2017	10/27/2017	4/14/2017	10/27/2017	4/14/2017	10/25/2017
	NYSDEC SCGs ⁽²⁾						
1,1,1-Trichloroethane	5	< 1.0	< 1.0	< 1.0	< 1.0	< 1.0	< 1.0
1,1,2,2-Tetrachloroethane	5	< 1.0	< 1.0	< 1.0	< 1.0	< 1.0	< 1.0
1,1,2-Trichloroethane	5	< 1.0	< 1.0	< 1.0	< 1.0	< 1.0	< 1.0
1,1-Dichloroethane	5	< 1.0	< 1.0	0.32 J	0.35 J	0.42 J	0.39 J
1,1-Dichloroethene	5	< 1.0	< 1.0	0.57 J	0.59 J	0.64 J	0.90 J
1,2-Dichloroethane	5	< 1.0	< 1.0	< 1.0	< 1.0	< 1.0	< 1.0
1,2-Dichloropropane	5	< 1.0	< 1.0	< 1.0	< 1.0	< 1.0	< 1.0
2-Butanone	50	< 10	< 10	< 10	< 10	< 10	< 10
2-Hexanone	50	< 5.0	< 5.0	< 5.0	< 5.0	< 5.0	< 5.0
4-methyl-2-pentanone	50	< 5.0	< 5.0	< 5.0	< 5.0	< 5.0	< 5.0
Acetone	50	< 10	< 10	< 10	< 10	< 10	< 10
Benzene	1	< 0.50	< 0.50	< 0.50	< 0.50	< 0.50	< 0.50
Bromodichloromethane	50	< 1.0	< 1.0	< 1.0	< 1.0	< 1.0	< 1.0
Bromoform	50	< 1.0	< 1.0	< 1.0	< 1.0	< 1.0	< 1.0
Bromomethane	5	< 2.0	< 2.0	< 2.0	< 2.0	< 2.0	< 2.0
Carbon Disulfide	50	< 2.0	< 2.0	< 2.0	< 2.0	< 2.0	< 2.0
Carbon tetrachloride	5	< 1.0	< 1.0	< 1.0	< 1.0	< 1.0	< 1.0
Chlorobenzene	5	< 1.0	< 1.0	< 1.0	< 1.0	< 1.0	< 1.0
Chloroethane	5	< 1.0	< 1.0	< 1.0	< 1.0	< 1.0	< 1.0
Chloroform	7	< 1.0	< 1.0	0.69 J	0.48 J	< 1.0	< 1.0
Chloromethane	5	< 1.0	< 1.0	< 1.0	< 1.0	< 1.0	< 1.0
cis-1,2-dichloroethene	5	< 1.0	< 1.0	0.54 J	< 1.0	< 1.0	< 1.0
cis-1,3-dichloropropene	5	< 1.0	< 1.0	< 1.0	< 1.0	< 1.0	< 1.0
Dibromochloromethane	5	< 1.0	< 1.0	< 1.0	< 1.0	< 1.0	< 1.0
Ethylbenzene	5	< 1.0	< 1.0	< 1.0	< 1.0	< 1.0	< 1.0
Methylene Chloride	5	< 2.0	< 2.0	< 2.0	< 2.0	< 2.0	< 2.0
Styrene	5	< 1.0	< 1.0	< 1.0	< 1.0	< 1.0	< 1.0
Tetrachloroethene	5	< 1.0	< 1.0	2.7	2.3	3.5	3.3
Toluene	5	< 1.0	< 1.0	< 1.0	< 1.0	< 1.0	< 1.0
trans-1,2-dichloroethene	5	< 1.0	< 1.0	< 1.0	< 1.0	< 1.0	< 1.0
trans-1,3-dichloropropene	5	< 1.0	< 1.0	< 1.0	< 1.0	< 1.0	< 1.0
Trichloroethylene	5	4.4	20.2	35.7	33.1	7.8	7.8
Trichlorotrifluoroethane (Freon 113)	5	< 5.0	< 5.0	< 5.0	< 5.0	< 5.0	< 5.0
Vinyl Chloride	2	< 1.0	< 1.0	< 1.0	< 1.0	< 1.0	< 1.0
Xylene-o	5	< 1.0	< 1.0	< 1.0	< 1.0	< 1.0	< 1.0
Xylenes - m,p	5	< 1.0	< 1.0	< 1.0	< 1.0	< 1.0	< 1.0
TVOCs		4.4	20	41	37	12	13

See Notes and Abbreviations on last page.

Table 13
Concentrations of Volatile Organic Compounds in
Groundwater Samples Collected from Wells
in the Deep 2 Zone⁽¹⁾, Operable Unit 2,
Northrop Grumman Systems Corporation
Bethpage, New York.

Constituents units in (ug/L)	Well ID:	GM-75D2	GM-75D2	GM-78D	GM-78D	GM-78D2
	Sample ID:	GM-75D2	GM-75D2	GM-78D	GM-78D	GM-78D2
	Sample Date:	6/12/2017	10/19/2017	5/4/2017	11/1/2017	5/4/2017
	NYSDEC SCGs ⁽²⁾					
1,1,1-Trichloroethane	5	< 1.0	< 1.0	< 1.0	< 1.0	< 1.0
1,1,2,2-Tetrachloroethane	5	< 1.0	< 1.0	< 1.0	< 1.0	< 1.0
1,1,2-Trichloroethane	5	< 1.0	< 1.0	< 1.0	< 1.0	< 1.0
1,1-Dichloroethane	5	< 1.0	< 1.0	< 1.0	< 1.0	< 1.0
1,1-Dichloroethene	5	< 1.0	< 1.0	< 1.0	< 1.0	< 1.0
1,2-Dichloroethane	5	< 1.0	< 1.0	< 1.0	< 1.0	< 1.0
1,2-Dichloropropane	5	< 1.0	< 1.0	< 1.0	< 1.0	< 1.0
2-Butanone	50	< 10	< 10	< 10	< 10	< 10
2-Hexanone	50	< 5.0	< 5.0	< 5.0	< 5.0	< 5.0
4-methyl-2-pentanone	50	< 5.0	< 5.0	< 5.0	< 5.0	< 5.0
Acetone	50	< 10	< 10	< 10	< 10	< 10
Benzene	1	< 0.50	< 0.50	< 0.50	< 0.50	< 0.50
Bromodichloromethane	50	< 1.0	< 1.0	< 1.0	< 1.0	< 1.0
Bromoform	50	< 1.0	< 1.0	< 1.0	< 1.0	< 1.0
Bromomethane	5	< 2.0	< 2.0	< 2.0	< 2.0	< 2.0
Carbon Disulfide	50	< 2.0	< 2.0	< 2.0	< 2.0	< 2.0
Carbon tetrachloride	5	< 1.0	< 1.0	< 1.0	< 1.0	< 1.0
Chlorobenzene	5	< 1.0	< 1.0	< 1.0	< 1.0	< 1.0
Chloroethane	5	< 1.0	< 1.0	< 1.0	< 1.0	< 1.0
Chloroform	7	< 1.0	< 1.0	< 1.0	< 1.0	< 1.0
Chloromethane	5	< 1.0	< 1.0	< 1.0	< 1.0	< 1.0
cis-1,2-dichloroethene	5	< 1.0	< 1.0	< 1.0	< 1.0	< 1.0
cis-1,3-dichloropropene	5	< 1.0	< 1.0	< 1.0	< 1.0	< 1.0
Dibromochloromethane	5	< 1.0	< 1.0	< 1.0	< 1.0	< 1.0
Ethylbenzene	5	< 1.0	< 1.0	< 1.0	< 1.0	< 1.0
Methylene Chloride	5	< 2.0	< 2.0	< 2.0	< 2.0	< 2.0
Styrene	5	< 1.0	< 1.0	< 1.0	< 1.0	< 1.0
Tetrachloroethene	5	1.0	0.82 J	< 1.0	< 1.0	< 1.0
Toluene	5	< 1.0	< 1.0	< 1.0	< 1.0	< 1.0
trans-1,2-dichloroethene	5	< 1.0	< 1.0	< 1.0	< 1.0	< 1.0
trans-1,3-dichloropropene	5	< 1.0	< 1.0	< 1.0	< 1.0	< 1.0
Trichloroethylene	5	26.4	18.3	3.5	3.1	1.6
Trichlorotrifluoroethane (Freon 113)	5	< 5.0	< 5.0	< 5.0	< 5.0	< 5.0
Vinyl Chloride	2	< 1.0	< 1.0	< 1.0	< 1.0	< 1.0
Xylene-o	5	< 1.0	< 1.0	< 1.0	< 1.0	< 1.0
Xylenes - m,p	5	< 1.0	< 1.0	< 1.0	< 1.0	< 1.0
TVOCs		27	19	3.5	3.1	1.6

See Notes and Abbreviations on last page.

Table 13
Concentrations of Volatile Organic Compounds in
Groundwater Samples Collected from Wells
in the Deep 2 Zone⁽¹⁾, Operable Unit 2,
Northrop Grumman Systems Corporation
Bethpage, New York.

Constituents units in (ug/L)	Well ID:	GM-78D2	MW-3-1	MW-3-1
	Sample ID:	GM-78D2	MW-3-1	MW-3-1
	Sample Date:	11/1/2017	7/7/2017	11/3/2017
	NYSDEC SCGs ⁽²⁾			
1,1,1-Trichloroethane	5	< 1.0	0.63 J	0.58 J
1,1,2,2-Tetrachloroethane	5	< 1.0	< 1.0	< 1.0
1,1,2-Trichloroethane	5	< 1.0	< 1.0	< 1.0
1,1-Dichloroethane	5	< 1.0	2.8	3.5
1,1-Dichloroethene	5	< 1.0	2.5	2.2
1,2-Dichloroethane	5	< 1.0	< 1.0	< 1.0
1,2-Dichloropropane	5	< 1.0	0.28 J	< 1.0
2-Butanone	50	< 10	< 10	< 10
2-Hexanone	50	< 5.0	< 5.0	< 5.0
4-methyl-2-pentanone	50	< 5.0	< 5.0	< 5.0
Acetone	50	< 10	< 10	< 10
Benzene	1	< 0.50	< 0.50	< 0.50
Bromodichloromethane	50	< 1.0	< 1.0	< 1.0
Bromoform	50	< 1.0	< 1.0	< 1.0
Bromomethane	5	< 2.0	< 2.0	< 2.0
Carbon Disulfide	50	< 2.0	< 2.0	< 2.0
Carbon tetrachloride	5	< 1.0	< 1.0	< 1.0
Chlorobenzene	5	< 1.0	< 1.0	< 1.0
Chloroethane	5	< 1.0	0.69 J	< 1.0
Chloroform	7	< 1.0	0.52 J	0.43 J
Chloromethane	5	< 1.0	< 1.0	< 1.0
cis-1,2-dichloroethene	5	< 1.0	18.8	12.6
cis-1,3-dichloropropene	5	< 1.0	< 1.0	< 1.0
Dibromochloromethane	5	< 1.0	< 1.0	< 1.0
Ethylbenzene	5	< 1.0	< 1.0	< 1.0
Methylene Chloride	5	< 2.0	< 2.0	< 2.0
Styrene	5	< 1.0	< 1.0	< 1.0
Tetrachloroethene	5	< 1.0	11.3	10.6
Toluene	5	< 1.0	< 1.0	< 1.0
trans-1,2-dichloroethene	5	< 1.0	< 1.0	< 1.0
trans-1,3-dichloropropene	5	< 1.0	< 1.0	< 1.0
Trichloroethylene	5	1.4	119	94.0
Trichlorotrifluoroethane (Freon 113)	5	< 5.0	< 5.0	< 5.0
Vinyl Chloride	2	< 1.0	29.7	19.1
Xylene-o	5	< 1.0	< 1.0	< 1.0
Xylenes - m,p	5	< 1.0	< 1.0	< 1.0
TVOCs		1.4	180	140

See Notes and Abbreviations on last page.

Table 13
Concentrations of Volatile Organic Compounds in
Groundwater Samples Collected from Wells
in the Deep 2 Zone⁽¹⁾, Operable Unit 2,
Northrop Grumman Systems Corporation
Bethpage, New York.

Constituents units in (ug/L)	Well ID:	WELL 1	WELL 1	WELL 1	WELL 1
	Sample ID:	WELL 1	WELL 1	WELL 1	WELL 1
	Sample Date:	2/22/2017	6/27/2017	9/12/2017	12/13/2017
	NYSDEC SCGs ⁽²⁾				
1,1,1-Trichloroethane	5	0.35 J	0.32 J	<4.0	0.35 J
1,1,2,2-Tetrachloroethane	5	<1.0	<1.0	<4.0	<1.0
1,1,2-Trichloroethane	5	<1.0	<1.0	<4.0	<1.0
1,1-Dichloroethane	5	0.73 J	0.86 J	<4.0	0.77 J
1,1-Dichloroethene	5	2.7	3.3	<4.0	2.7
1,2-Dichloroethane	5	<1.0	<1.0	<4.0	<1.0
1,2-Dichloropropane	5	4.5	4.7	4.4	4.4
2-Butanone	50	<10	<10	<40	<10
2-Hexanone	50	<5.0	<5.0	<20	<5.0
4-methyl-2-pentanone	50	<5.0	<5.0	<20	<5.0
Acetone	50	<10	<10	<40	<10
Benzene	1	<0.50	<0.50	<2.0	<0.50
Bromodichloromethane	50	<1.0	<1.0	<4.0	<1.0
Bromoform	50	<1.0	<1.0	<4.0	<1.0
Bromomethane	5	<2.0	<2.0	<8.0	<2.0
Carbon Disulfide	50	<2.0	<2.0	<8.0	<2.0
Carbon tetrachloride	5	<1.0	<1.0	<4.0	<1.0
Chlorobenzene	5	<1.0	<1.0	<4.0	<1.0
Chloroethane	5	<1.0	<1.0	<4.0	<1.0
Chloroform	7	0.32 J	0.32 J	<4.0	0.35 J
Chloromethane	5	<1.0	<1.0	<4.0	<1.0
cis-1,2-dichloroethene	5	4.8	5.7	4.9	5.3
cis-1,3-dichloropropene	5	<1.0	<1.0	<4.0	<1.0
Dibromochloromethane	5	<1.0	<1.0	<4.0	<1.0
Ethylbenzene	5	<1.0	<1.0	<4.0	<1.0
Methylene Chloride	5	<2.0	<2.0	<8.0	<2.0
Styrene	5	<1.0	<1.0	<4.0	<1.0
Tetrachloroethene	5	28.1	22.4	21.7	22.4
Toluene	5	<1.0	<1.0	<4.0	<1.0
trans-1,2-dichloroethene	5	<1.0	<1.0	<4.0	<1.0
trans-1,3-dichloropropene	5	<1.0	<1.0	<4.0	<1.0
Trichloroethylene	5	702	622	603	608
Trichlorotrifluoroethane (Freon 113)	5	4.3 J	4.1 J	<20	3.8 J
Vinyl Chloride	2	<1.0	<1.0	<4.0	<1.0
Xylene-o	5	<1.0	<1.0	<4.0	<1.0
Xylenes - m,p	5	<1.0	<1.0	<4.0	<1.0
TVOCs		750	660	630	650

See Notes and Abbreviations on last page.

Table 13
Concentrations of Volatile Organic Compounds in
Groundwater Samples Collected from Wells
in the Deep 2 Zone⁽¹⁾, Operable Unit 2,
Northrop Grumman Systems Corporation
Bethpage, New York.

Constituents units in (ug/L)	Well ID:	WELL 3R	WELL 3R	WELL 3R	WELL 3R
	Sample ID:	WELL 3R	WELL 3R	WELL 3R	WELL 3R
	Sample Date:	2/14/2017	6/27/2017	9/12/2017 ⁽⁵⁾	12/13/2017
	NYSDEC SCGs ⁽²⁾				
1,1,1-Trichloroethane	5	0.78 J	0.61 J	0.68 J	0.68 J
1,1,2,2-Tetrachloroethane	5	<1.0	<1.0	<1.0	<1.0
1,1,2-Trichloroethane	5	<1.0	<1.0	<1.0	<1.0
1,1-Dichloroethane	5	1.4	1.6	1.5	1.5
1,1-Dichloroethene	5	4.9	4.8	4.1	4.1
1,2-Dichloroethane	5	<1.0	<1.0	<1.0	<1.0
1,2-Dichloropropane	5	<1.0	<1.0	<1.0	<1.0
2-Butanone	50	<10	<10	<10	<10
2-Hexanone	50	<5.0	<5.0	<5.0	<5.0
4-methyl-2-pentanone	50	<5.0	<5.0	<5.0	<5.0
Acetone	50	<10	<10	<10	<10
Benzene	1	<0.50	<0.50	<0.50	<0.50
Bromodichloromethane	50	<1.0	<1.0	<1.0	<1.0
Bromoform	50	<1.0	<1.0	<1.0	<1.0
Bromomethane	5	<2.0	<2.0	<2.0	<2.0
Carbon Disulfide	50	<2.0	<2.0	<2.0	<2.0
Carbon tetrachloride	5	<1.0	<1.0	<1.0	<1.0
Chlorobenzene	5	<1.0	<1.0	<1.0	<1.0
Chloroethane	5	<1.0	<1.0	<1.0	<1.0
Chloroform	7	<1.0	<1.0	<1.0	<1.0
Chloromethane	5	<1.0	<1.0	<1.0	<1.0
cis-1,2-dichloroethene	5	4.3	4.6	4.3	4.3
cis-1,3-dichloropropene	5	<1.0	<1.0	<1.0	<1.0
Dibromochloromethane	5	<1.0	<1.0	<1.0	<1.0
Ethylbenzene	5	<1.0	<1.0	<1.0	<1.0
Methylene Chloride	5	<2.0	<2.0	<2.0	<2.0
Styrene	5	<1.0	<1.0	<1.0	<1.0
Tetrachloroethene	5	30.9	27.1	30.5	27.8
Toluene	5	<1.0	<1.0	<1.0	<1.0
trans-1,2-dichloroethene	5	<1.0	<1.0	<1.0	<1.0
trans-1,3-dichloropropene	5	<1.0	<1.0	<1.0	<1.0
Trichloroethylene	5	498	397	365	362
Trichlorotrifluoroethane (Freon 113)	5	4.0 J	3.8 J	3.5 J	3.5 J
Vinyl Chloride	2	3.9	3.5	2.7	2.1
Xylene-o	5	<1.0	<1.0	<1.0	<1.0
Xylenes - m,p	5	<1.0	<1.0	<1.0	<1.0
TVOCs		550	440	410	400

See Notes and Abbreviations on last page.

Table 13
Concentrations of Volatile Organic Compounds in
Groundwater Samples Collected from Wells
in the Deep 2 Zone⁽¹⁾, Operable Unit 2,
Northrop Grumman Systems Corporation
Bethpage, New York.

Constituents units in (ug/L)	Well ID:	WELL 17	WELL 17	WELL 17	WELL 17	WELL 18
	Sample ID:	WELL 17	WELL 17	WELL 17	WELL 17	WELL 18
	Sample Date:	2/14/2017	6/29/2017	9/12/2017 ⁽⁵⁾	12/13/2017	2/14/2017
	NYSDEC SCGs ⁽²⁾					
1,1,1-Trichloroethane	5	0.28 J	<1.0	0.25 J	0.29 J	0.43 J
1,1,2,2-Tetrachloroethane	5	<1.0	<1.0	<1.0	<1.0	<1.0
1,1,2-Trichloroethane	5	<1.0	<1.0	<1.0	<1.0	<1.0
1,1-Dichloroethane	5	0.89 J	0.95 J	0.86 J	0.91 J	1.2
1,1-Dichloroethene	5	1.9	1.8	1.7	1.8	<1.0
1,2-Dichloroethane	5	<1.0	<1.0	<1.0	<1.0	<1.0
1,2-Dichloropropane	5	<1.0	<1.0	0.27 J	<1.0	<1.0
2-Butanone	50	<10	<10	<10	<10	<10
2-Hexanone	50	<5.0	<5.0	<5.0	<5.0	<5.0
4-methyl-2-pentanone	50	<5.0	<5.0	<5.0	<5.0	<5.0
Acetone	50	<10	<10	<10	<10	<10
Benzene	1	<0.50	<0.50	<0.50	<0.50	<0.50
Bromodichloromethane	50	<1.0	<1.0	<1.0	<1.0	<1.0
Bromoform	50	<1.0	<1.0	<1.0	<1.0	<1.0
Bromomethane	5	<2.0	<2.0	<2.0	<2.0	<2.0
Carbon Disulfide	50	<2.0	<2.0	<2.0	<2.0	<2.0
Carbon tetrachloride	5	<1.0	<1.0	<1.0	<1.0	<1.0
Chlorobenzene	5	<1.0	<1.0	<1.0	<1.0	<1.0
Chloroethane	5	<1.0	<1.0	<1.0	<1.0	<1.0
Chloroform	7	0.24 J	<1.0	<1.0	<1.0	<1.0
Chloromethane	5	<1.0	<1.0	<1.0	<1.0	<1.0
cis-1,2-dichloroethene	5	2.8	3.0	2.8	3.0	2.1
cis-1,3-dichloropropene	5	<1.0	<1.0	<1.0	<1.0	<1.0
Dibromochloromethane	5	<1.0	<1.0	<1.0	<1.0	<1.0
Ethylbenzene	5	<1.0	<1.0	<1.0	<1.0	<1.0
Methylene Chloride	5	<2.0	<2.0	<2.0	<2.0	<2.0
Styrene	5	<1.0	<1.0	<1.0	<1.0	<1.0
Tetrachloroethene	5	23.3	22.0	21.6	21.8	13.0
Toluene	5	<1.0	<1.0	<1.0	<1.0	<1.0
trans-1,2-dichloroethene	5	<1.0	<1.0	<1.0	<1.0	<1.0
trans-1,3-dichloropropene	5	<1.0	<1.0	<1.0	<1.0	<1.0
Trichloroethylene	5	116	116	105	116	46.1
Trichlorotrifluoroethane (Freon 113)	5	3.3 J	3.4 J	2.8 J	3.3 J	1.3 J
Vinyl Chloride	2	<1.0	<1.0	<1.0	<1.0	<1.0
Xylene-o	5	<1.0	<1.0	<1.0	<1.0	<1.0
Xylenes - m,p	5	<1.0	<1.0	<1.0	<1.0	<1.0
TVOCs		150	150	130	150	64

See Notes and Abbreviations on last page.

Table 13
Concentrations of Volatile Organic Compounds in
Groundwater Samples Collected from Wells
in the Deep 2 Zone⁽¹⁾, Operable Unit 2,
Northrop Grumman Systems Corporation
Bethpage, New York.

Constituents units in (ug/L)	Well ID:	WELL 18	WELL 18	WELL 18
	Sample ID:	WELL 18	WELL 18	WELL 18
	Sample Date:	6/27/2017	9/12/2017 ⁽⁵⁾	12/13/2017
	NYSDEC SCGs ⁽²⁾			
1,1,1-Trichloroethane	5	0.44 J	0.42 J	0.51 J
1,1,2,2-Tetrachloroethane	5	<1.0	<1.0	<1.0
1,1,2-Trichloroethane	5	<1.0	<1.0	<1.0
1,1-Dichloroethane	5	1.3	1.2	1.4
1,1-Dichloroethene	5	4.0	3.1	3.4
1,2-Dichloroethane	5	<1.0	<1.0	<1.0
1,2-Dichloropropane	5	<1.0	<1.0	<1.0
2-Butanone	50	<10	<10	<10
2-Hexanone	50	<5.0	<5.0	<5.0
4-methyl-2-pentanone	50	<5.0	<5.0	<5.0
Acetone	50	<10	<10	<10
Benzene	1	<0.50	<0.50	<0.50
Bromodichloromethane	50	<1.0	<1.0	<1.0
Bromoform	50	<1.0	<1.0	<1.0
Bromomethane	5	<2.0	<2.0	<2.0
Carbon Disulfide	50	<2.0	<2.0	<2.0
Carbon tetrachloride	5	<1.0	<1.0	<1.0
Chlorobenzene	5	<1.0	<1.0	<1.0
Chloroethane	5	<1.0	<1.0	<1.0
Chloroform	7	<1.0	<1.0	<1.0
Chloromethane	5	<1.0	<1.0	<1.0
cis-1,2-dichloroethene	5	2.7	2.7	2.7
cis-1,3-dichloropropene	5	<1.0	<1.0	<1.0
Dibromochloromethane	5	<1.0	<1.0	<1.0
Ethylbenzene	5	<1.0	<1.0	<1.0
Methylene Chloride	5	<2.0	<2.0	<2.0
Styrene	5	<1.0	<1.0	<1.0
Tetrachloroethene	5	11.9	13.8	13.9
Toluene	5	<1.0	<1.0	<1.0
trans-1,2-dichloroethene	5	<1.0	<1.0	<1.0
trans-1,3-dichloropropene	5	<1.0	<1.0	<1.0
Trichloroethylene	5	45.1	44.5	45.0
Trichlorotrifluoroethane (Freon 113)	5	1.4 J	1.2 J	1.5 J
Vinyl Chloride	2	<1.0	<1.0	<1.0
Xylene-o	5	<1.0	<1.0	<1.0
Xylenes - m,p	5	<1.0	<1.0	<1.0
TVOCs		67	67	68

See Notes and Abbreviations on last page.

Table 13
Concentrations of Volatile Organic Compounds in
Groundwater Samples Collected from Wells
in the Deep 2 Zone⁽¹⁾, Operable Unit 2,
Northrop Grumman Systems Corporation
Bethpage, New York.

Constituents units in (ug/L)	Well ID:	WELL 19	WELL 19	WELL 19	WELL 19
	Sample ID:	WELL 19	WELL 19	WELL 19	WELL 19
	Sample Date:	2/14/2017	6/27/2017	9/12/2017 ⁽⁵⁾	12/13/2017
	NYSDEC SCGs ⁽²⁾				
1,1,1-Trichloroethane	5	0.33 J	0.30 J	0.28 J	0.27 J
1,1,2,2-Tetrachloroethane	5	<1.0	<1.0	<1.0	<1.0
1,1,2-Trichloroethane	5	<1.0	<1.0	<1.0	<1.0
1,1-Dichloroethane	5	0.71 J	0.76 J	0.66 J	0.68 J
1,1-Dichloroethene	5	1.5	1.9	1.4	1.5
1,2-Dichloroethane	5	<1.0	0.34 J	0.30 J	0.25 J
1,2-Dichloropropane	5	<1.0	<1.0	<1.0	<1.0
2-Butanone	50	<10	<10	<10	<10
2-Hexanone	50	<5.0	<5.0	<5.0	<5.0
4-methyl-2-pentanone	50	<5.0	<5.0	<5.0	<5.0
Acetone	50	<10	<10	<10	<10
Benzene	1	<0.50	<0.50	<0.50	<0.50
Bromodichloromethane	50	<1.0	<1.0	<1.0	<1.0
Bromoform	50	<1.0	<1.0	<1.0	<1.0
Bromomethane	5	<2.0	<2.0	<2.0	<2.0
Carbon Disulfide	50	<2.0	<2.0	<2.0	<2.0
Carbon tetrachloride	5	<1.0	<1.0	<1.0	<1.0
Chlorobenzene	5	<1.0	<1.0	<1.0	<1.0
Chloroethane	5	<1.0	<1.0	<1.0	<1.0
Chloroform	7	0.37 J	0.48 J	0.40 J	0.36 J
Chloromethane	5	<1.0	<1.0	<1.0	<1.0
cis-1,2-dichloroethene	5	16.1	19.4	16.5	15.1
cis-1,3-dichloropropene	5	<1.0	<1.0	<1.0	<1.0
Dibromochloromethane	5	<1.0	<1.0	<1.0	<1.0
Ethylbenzene	5	<1.0	<1.0	<1.0	<1.0
Methylene Chloride	5	<2.0	<2.0	<2.0	<2.0
Styrene	5	<1.0	<1.0	<1.0	<1.0
Tetrachloroethene	5	6.6	6.0	6.7	6.4
Toluene	5	<1.0	<1.0	<1.0	<1.0
trans-1,2-dichloroethene	5	<1.0	<1.0	<1.0	<1.0
trans-1,3-dichloropropene	5	<1.0	<1.0	<1.0	<1.0
Trichloroethylene	5	139	132	118	118
Trichlorotrifluoroethane (Freon 113)	5	<5.0	<5.0	<5.0	<5.0
Vinyl Chloride	2	<1.0	<1.0	<1.0	<1.0
Xylene-o	5	<1.0	<1.0	<1.0	<1.0
Xylenes - m,p	5	<1.0	<1.0	<1.0	<1.0
TVOCs		170	160	140	140

See Notes and Abbreviations on last page.

Table 13
Concentrations of Volatile Organic Compounds in
Groundwater Samples Collected from Wells
in the Deep 2 Zone⁽¹⁾, Operable Unit 2,
Northrop Grumman Systems Corporation
Bethpage, New York.

Notes and Abbreviations:

- (1) Well identification (e.g., GM-34D) does not necessarily designate the actual hydrogeologic zone. Determination of the hydrogeologic zone is based on the well screen interval and the regional model layering.
- (2) Standards, Criteria, and Guidance (SCG) values based on documents referenced in the Groundwater Feasibility Study Report (ARCADIS Geraghty & Miller, Inc. 2000) that are based on the NYSDEC TOGs (NYSDEC 1998); most stringent values are listed.

Results for the program are validated at 20% frequency, per protocols specified in OU2 Groundwater Monitoring Plan (Arcadis 2016)
Samples analyzed for the TCL VOCs using USEPA Method 8260C.

TVOCs are rounded to two significant figures.

Bold value indicates a detection.

NYSDEC New York State Department of Environmental Conservation

USEPA United States Environmental Protection Agency

VOCs Volatile Organic Compounds

TVOCs Total Volatile Organic Compounds

µg/L micrograms per liter

SCG Standards, Criteria and Guidance Value

D Sample is diluted

J Value is estimated concentration.

Compound detected in exceedance of NYSDEC SCG Criteria

Table 14
Concentrations of Volatile Organic Compounds
in Groundwater Samples Collected from Wells
in the Deep 3 Zone⁽¹⁾, Operable Unit 2,
Northrop Grumman Systems Corporation
Bethpage, New York.

Constituents units in (ug/L)	Well ID: Sample ID: Sample Date:	GM-73D3 GM-73D3 6/29/2017	GM-73D3 GM-73D3 10/27/2017	GM-74D3 GM-74D3 7/10/2017	GM-74D3 GM-74D3 10/25/2017
	NYSDEC SCGs ⁽²⁾				
1,1,1-Trichloroethane	5	< 1.0	< 1.0	< 1.0	< 1.0
1,1,1,2,2-Tetrachloroethane	5	< 1.0	< 1.0	< 1.0	< 1.0
1,1,1,2-Trichloroethane	5	< 1.0	< 1.0	< 1.0	< 1.0
1,1-Dichloroethane	5	< 1.0	< 1.0	< 1.0	< 1.0
1,1-Dichloroethene	5	< 1.0	< 1.0	< 1.0	< 1.0
1,2-Dichloroethane	5	< 1.0	< 1.0	< 1.0	< 1.0
1,2-Dichloropropane	5	< 1.0	< 1.0	< 1.0	< 1.0
2-Butanone	50	< 10	< 10	< 10	< 10
2-Hexanone	50	< 5.0	< 5.0	< 5.0	< 5.0
4-methyl-2-pentanone	50	< 5.0	< 5.0	< 5.0	< 5.0
Acetone	50	< 10	< 10	< 10	< 10
Benzene	1	< 0.50	< 0.50	< 0.50	< 0.50
Bromodichloromethane	50	< 1.0	< 1.0	< 1.0	< 1.0
Bromoform	50	< 1.0	< 1.0	< 1.0	< 1.0
Bromomethane	5	< 2.0	< 2.0	< 2.0	< 2.0
Carbon Disulfide	50	< 2.0	< 2.0	< 2.0	< 2.0
Carbon tetrachloride	5	< 1.0	< 1.0	< 1.0	< 1.0
Chlorobenzene	5	< 1.0	< 1.0	< 1.0	< 1.0
Chloroethane	5	< 1.0	< 1.0	< 1.0	< 1.0
Chloroform	7	< 1.0	< 1.0	< 1.0	< 1.0
Chloromethane	5	< 1.0	< 1.0	< 1.0	< 1.0
cis-1,2-dichloroethene	5	< 1.0	< 1.0	< 1.0	< 1.0
cis-1,3-dichloropropene	5	< 1.0	< 1.0	< 1.0	< 1.0
Dibromochloromethane	5	< 1.0	< 1.0	< 1.0	< 1.0
Ethylbenzene	5	< 1.0	< 1.0	< 1.0	< 1.0
Methylene Chloride	5	< 2.0	< 2.0	< 2.0	< 2.0
Styrene	5	< 1.0	< 1.0	< 1.0	< 1.0
Tetrachloroethene	5	< 1.0	0.98 J	3.0	3.5
Toluene	5	< 1.0	< 1.0	< 1.0	< 1.0
trans-1,2-dichloroethene	5	< 1.0	< 1.0	< 1.0	< 1.0
trans-1,3-dichloropropene	5	< 1.0	< 1.0	< 1.0	< 1.0
Trichloroethylene	5	1.5	1.8	5.8	5.85
Trichlorotrifluoroethane (Freon 113)	5	< 5.0	< 5.0	< 5.0	< 5.0
Vinyl Chloride	2	< 1.0	< 1.0	< 1.0	< 1.0
Xylene-o	5	< 1.0	< 1.0	< 1.0	< 1.0
Xylenes - m,p	5	< 1.0	< 1.0	< 1.0	< 1.0
TVOCs		1.5	2.8	8.8	9.4

See Notes and Abbreviations on Last Page

Table 14
Concentrations of Volatile Organic Compounds
in Groundwater Samples Collected from Wells
in the Deep 3 Zone⁽¹⁾, Operable Unit 2,
Northrop Grumman Systems Corporation
Bethpage, New York.

Notes and Abbreviations:

- (1) Well identification (e.g., GM-73D3) does not necessarily designate the actual hydrogeologic zone. Determination of the hydrogeologic zone is based on the well screen interval and the regional model layering.
- (2) Standards, Criteria, and Guidance (SCG) values based on documents referenced in the Groundwater Feasibility Study Report (ARCADIS Geraghty & Miller, Inc. 2000) that are based on the NYSDEC TOGs (NYSDEC 1998); most stringent values are listed.

Results for the program are validated at 20% frequency, per protocols specified in OU2 Groundwater Monitoring Plan (Arcadis 2016)
 Samples analyzed for the TCL VOCs using USEPA Method 8260C.

TVOCs are rounded to two significant figures.

Bold value indicates a detection.

NYSDEC New York State Department of Environmental Conservation

USEPA United States Environmental Protection Agency

VOCs Volatile Organic Compounds

TVOCs Total Volatile Organic Compounds

µg/L micrograms per liter

SCG Standards, Criteria and Guidance Value

J Value is estimated concentration.

OU2 Operable Unit 2

TCL Target Compound List

TOGs Technical and Operational Guidance Series

< 5.0 Compound not detected above its laboratory quantification limit

Compound detected in exceedance of NYSDEC SCG Criteria

Table 15
Concentrations of Volatile Organic Compounds
in Outpost Wells ⁽¹⁾, 2017
Operable Unit 2 Northrop Grumman Systems Corporation
Bethpage, New York

Constituents units in (ug/L)	Well ID: Sample ID: Sample Date:	BPOW 1-1 BPOW 1-1 6/19/2017	BPOW 1-1 BPOW 1-1 11/3/2017	BPOW 1-2 BPOW 1-2 6/13/2017	BPOW 1-2 BPOW 1-2 11/2/2017	BPOW 1-3 BPOW 1-3 6/13/2017
	NYSDEC SCG (ug/L) ⁽²⁾					
1,1,1-Trichloroethane	5	0.20 J	0.44 J	0.23 J	0.22 J	< 0.50
1,1,1,2,2-Tetrachloroethane	5	< 0.50	< 0.50	< 0.50	< 0.50	< 0.50
1,1,2-Trichloroethane	5	< 0.50	< 0.50	< 0.50	< 0.50	< 0.50
1,1-Dichloroethane	5	< 0.50	0.16 J	< 0.50	< 0.50	< 0.50
1,1-Dichloroethene	5	< 0.50	0.46 J	< 0.50	< 0.50	< 0.50
1,2-Dichloroethane	5	< 0.50	< 0.50	< 0.50	< 0.50	< 0.50
1,2-Dichloropropane	5	< 0.50	< 0.50	< 0.50	< 0.50	< 0.50
2-Butanone (MEK)	50	< 5.0	< 5.0	< 5.0	< 5.0	< 5.0
Methyl N-Butyl Ketone (2-Hexanone)	50	< 2.0	< 2.0	< 2.0	< 2.0	< 2.0
4-Methyl-2-Pentanone	50	< 2.0	< 2.0	< 2.0	< 2.0	< 2.0
Acetone	50	< 5.0	< 5.0	< 5.0	< 5.0	< 5.0
Benzene	1	< 0.50	< 0.50	< 0.50	< 0.50	< 0.50
Bromodichloromethane	50	< 0.50	< 0.50	< 0.50	< 0.50	< 0.50
Bromoform	50	< 0.50	< 0.50	< 0.50	< 0.50	< 0.50
Bromomethane	5	< 0.50	< 0.50	< 0.50	< 0.50	< 0.50
Carbon Disulfide	50	< 0.50	< 0.50	< 0.50	< 0.50	< 0.50
Carbon Tetrachloride	5	< 0.50	< 0.50	< 0.50	< 0.50	< 0.50
Chlorobenzene	5	< 0.50	< 0.50	< 0.50	< 0.50	< 0.50
Chloroethane	5	< 0.50	< 0.50	< 0.50	< 0.50	< 0.50
Chloroform	7	< 0.50	< 0.50	< 0.50	< 0.50	< 0.50
Chloromethane	5	< 0.50	< 0.50	< 0.50	< 0.50	< 0.50
cis-1,2-Dichloroethene	5	< 0.50	< 0.50	< 0.50	< 0.50	< 0.50
cis-1,3-Dichloropropene	5	< 0.50	< 0.50	< 0.50	< 0.50	< 0.50
Dibromochloromethane	5	< 0.50	< 0.50	< 0.50	< 0.50	< 0.50
Ethylbenzene	5	< 0.50	< 0.50	< 0.50	< 0.50	< 0.50
Methylene Chloride	5	< 0.50	< 0.50	< 0.50	< 0.50	< 0.50
Styrene (Monomer)	5	< 0.50	< 0.50	< 0.50	< 0.50	< 0.50
Tetrachloroethene	5	< 0.50	< 0.50	< 0.50	< 0.50	< 0.50
Toluene	5	< 0.50	< 0.50	< 0.50	< 0.50	< 0.50
trans-1,2-Dichloroethene	5	< 0.50	< 0.50	< 0.50	< 0.50	< 0.50
trans-1,3-Dichloropropene	5	< 0.50	< 0.50	< 0.50	< 0.50	< 0.50
Trichloroethene	5	1.0	1.1	0.88	0.90	< 0.50
Trichlorotrifluoroethane (Freon)	5	< 1.0	< 1.0	< 1.0	< 1.0	< 1.0
Vinyl chloride	2	< 0.50	< 0.50	< 0.50	< 0.50	< 0.50
o-Xylene	5	< 0.50	< 0.50	< 0.50	< 0.50	< 0.50
m,p-Xylene	5	< 0.50	< 0.50	< 0.50	< 0.50	< 0.50
TVOCs		1.2	2.2	1.1	1.1	0

Notes and abbreviations on last page.

Table 15
Concentrations of Volatile Organic Compounds
in Outpost Wells ⁽¹⁾, 2017
Operable Unit 2 Northrop Grumman Systems Corporation
Bethpage, New York

Constituents units in (ug/L)	Well ID: Sample ID: Sample Date:	BPOW 1-3 BPOW 1-3 11/3/2017	BPOW 1-4 BPOW 1-4 6/12/2017	BPOW 1-4 BPOW 1-4 11/8/2017	BPOW 1-5 BPOW 1-5 6/12/2017	BPOW 1-5 BPOW 1-5 11/8/2017
	NYSDEC SCG (ug/L) ⁽²⁾					
1,1,1-Trichloroethane	5	< 0.50	< 0.50	< 0.50	< 0.50	< 0.50
1,1,1,2,2-Tetrachloroethane	5	< 0.50	< 0.50	< 0.50	< 0.50	< 0.50
1,1,2-Trichloroethane	5	< 0.50	< 0.50	< 0.50	< 0.50	< 0.50
1,1-Dichloroethane	5	< 0.50	< 0.50	< 0.50	< 0.50	< 0.50
1,1-Dichloroethene	5	< 0.50	< 0.50	< 0.50	< 0.50	< 0.50
1,2-Dichloroethane	5	< 0.50	< 0.50	< 0.50	< 0.50	< 0.50
1,2-Dichloropropane	5	< 0.50	< 0.50	< 0.50	< 0.50	< 0.50
2-Butanone (MEK)	50	< 5.0	< 5.0	< 5.0	< 5.0	< 5.0
Methyl N-Butyl Ketone (2-Hexanone)	50	< 2.0	< 2.0	< 2.0	< 2.0	< 2.0
4-Methyl-2-Pentanone	50	< 2.0	< 2.0	< 2.0	< 2.0	< 2.0
Acetone	50	< 5.0	< 5.0	< 5.0	< 5.0	< 5.0
Benzene	1	< 0.50	< 0.50	< 0.50	< 0.50	< 0.50
Bromodichloromethane	50	< 0.50	< 0.50	< 0.50	< 0.50	< 0.50
Bromoform	50	< 0.50	< 0.50	< 0.50	< 0.50	< 0.50
Bromomethane	5	< 0.50	< 0.50	< 0.50	< 0.50	< 0.50
Carbon Disulfide	50	< 0.50	< 0.50	< 0.50	< 0.50	< 0.50
Carbon Tetrachloride	5	< 0.50	< 0.50	< 0.50	< 0.50	< 0.50
Chlorobenzene	5	< 0.50	< 0.50	< 0.50	< 0.50	< 0.50
Chloroethane	5	< 0.50	< 0.50	< 0.50	< 0.50	< 0.50
Chloroform	7	< 0.50	< 0.50	< 0.50	< 0.50	< 0.50
Chloromethane	5	< 0.50	< 0.50	< 0.50	< 0.50	< 0.50
cis-1,2-Dichloroethene	5	< 0.50	< 0.50	< 0.50	< 0.50	< 0.50
cis-1,3-Dichloropropene	5	< 0.50	< 0.50	< 0.50	< 0.50	< 0.50
Dibromochloromethane	5	< 0.50	< 0.50	< 0.50	< 0.50	< 0.50
Ethylbenzene	5	< 0.50	< 0.50	< 0.50	< 0.50	< 0.50
Methylene Chloride	5	< 0.50	< 0.50	< 0.50	< 0.50	< 0.50
Styrene (Monomer)	5	< 0.50	< 0.50	< 0.50	< 0.50	< 0.50
Tetrachloroethene	5	< 0.50	< 0.50	< 0.50	< 0.50	< 0.50
Toluene	5	< 0.50	< 0.50	0.20 J	< 0.50	< 0.50
trans-1,2-Dichloroethene	5	< 0.50	< 0.50	< 0.50	< 0.50	< 0.50
trans-1,3-Dichloropropene	5	< 0.50	< 0.50	< 0.50	< 0.50	< 0.50
Trichloroethene	5	< 0.50	< 0.50	< 0.50	< 0.50	< 0.50
Trichlorotrifluoroethane (Freon)	5	< 1.0	< 1.0	< 1.0	< 1.0	< 1.0
Vinyl chloride	2	< 0.50	< 0.50	< 0.50	< 0.50	< 0.50
o-Xylene	5	< 0.50	< 0.50	< 0.50	< 0.50	< 0.50
m,p-Xylene	5	< 0.50	< 0.50	< 0.50	< 0.50	< 0.50
TVOCs		0	0	0.20	0	0

Notes and abbreviations on last page.

Table 15
Concentrations of Volatile Organic Compounds
in Outpost Wells ⁽¹⁾, 2017
Operable Unit 2 Northrop Grumman Systems Corporation
Bethpage, New York

Constituents units in (ug/L)	Well ID: Sample ID: Sample Date:	BPOW 1-6 BPOW 1-6 6/27/2017	BPOW 1-6 BPOW 1-6 11/8/2017	BPOW 2-1 BPOW 2-1 2/21/2017	BPOW 2-1 BPOW 2-1 5/10/2017	BPOW 2-1 BPOW 2-1 9/12/2017
	NYSDEC SCG (ug/L) ⁽²⁾					
1,1,1-Trichloroethane	5	< 0.50	< 0.50	< 0.50	< 0.50	< 0.50
1,1,1,2,2-Tetrachloroethane	5	< 0.50	< 0.50	< 0.50	< 0.50	< 0.50
1,1,2-Trichloroethane	5	< 0.50	< 0.50	< 0.50	< 0.50	< 0.50
1,1-Dichloroethane	5	< 0.50	< 0.50	< 0.50	< 0.50	< 0.50
1,1-Dichloroethene	5	< 0.50	< 0.50	< 0.50	< 0.50	< 0.50
1,2-Dichloroethane	5	< 0.50	< 0.50	< 0.50	< 0.50	< 0.50
1,2-Dichloropropane	5	< 0.50	< 0.50	< 0.50	< 0.50	< 0.50
2-Butanone (MEK)	50	< 5.0	< 5.0	< 5.0	< 5.0	< 5.0
Methyl N-Butyl Ketone (2-Hexanone)	50	< 2.0	< 2.0	< 2.0	< 2.0	< 2.0
4-Methyl-2-Pentanone	50	< 2.0	< 2.0	< 2.0	< 2.0	< 2.0
Acetone	50	< 5.0	< 5.0	< 5.0	< 5.0	< 5.0
Benzene	1	< 0.50	< 0.50	< 0.50	< 0.50	< 0.50
Bromodichloromethane	50	< 0.50	< 0.50	< 0.50	< 0.50	< 0.50
Bromoform	50	< 0.50	< 0.50	< 0.50	< 0.50	< 0.50
Bromomethane	5	< 0.50	< 0.50	< 0.50	< 0.50	< 0.50
Carbon Disulfide	50	< 0.50	< 0.50	< 0.50	< 0.50	< 0.50
Carbon Tetrachloride	5	< 0.50	< 0.50	< 0.50	< 0.50	< 0.50
Chlorobenzene	5	< 0.50	< 0.50	< 0.50	< 0.50	< 0.50
Chloroethane	5	< 0.50	< 0.50	< 0.50	< 0.50	< 0.50
Chloroform	7	< 0.50	< 0.50	< 0.50	< 0.50	< 0.50
Chloromethane	5	< 0.50	< 0.50	< 0.50	< 0.50	< 0.50
cis-1,2-Dichloroethene	5	< 0.50	< 0.50	< 0.50	< 0.50	< 0.50
cis-1,3-Dichloropropene	5	< 0.50	< 0.50	< 0.50	< 0.50	< 0.50
Dibromochloromethane	5	< 0.50	< 0.50	< 0.50	< 0.50	< 0.50
Ethylbenzene	5	< 0.50	< 0.50	< 0.50	< 0.50	< 0.50
Methylene Chloride	5	< 0.50	< 0.50	< 0.50	< 0.50	< 0.50
Styrene (Monomer)	5	< 0.50	< 0.50	< 0.50	< 0.50	< 0.50
Tetrachloroethene	5	< 0.50	< 0.50	< 0.50	< 0.50	< 0.50
Toluene	5	< 0.50	< 0.50	< 0.50	< 0.50	< 0.50
trans-1,2-Dichloroethene	5	< 0.50	< 0.50	< 0.50	< 0.50	< 0.50
trans-1,3-Dichloropropene	5	< 0.50	< 0.50	< 0.50	< 0.50	< 0.50
Trichloroethene	5	< 0.50	< 0.50	< 0.50	< 0.50	< 0.50
Trichlorotrifluoroethane (Freon)	5	< 1.0	< 1.0	< 1.0	< 1.0	< 1.0
Vinyl chloride	2	< 0.50	< 0.50	< 0.50	< 0.50	< 0.50
o-Xylene	5	< 0.50	< 0.50	< 0.50	< 0.50	< 0.50
m,p-Xylene	5	< 0.50	< 0.50	< 0.50	< 0.50	< 0.50
TVOCs		0	0	0	0	0

Notes and abbreviations on last page.

Table 15
Concentrations of Volatile Organic Compounds
in Outpost Wells ⁽¹⁾, 2017
Operable Unit 2 Northrop Grumman Systems Corporation
Bethpage, New York

Constituents units in (ug/L)	Well ID: Sample ID: Sample Date:	BPOW 2-1 BPOW 2-1 10/23/2017	BPOW 2-2 BPOW 2-2 2/21/2017	BPOW 2-2 BPOW 2-2 5/10/2017	BPOW 2-2 BPOW 2-2 9/12/2017	BPOW 2-2 BPOW 2-2 10/23/2017
	NYSDEC SCG (ug/L) ⁽²⁾					
1,1,1-Trichloroethane	5	< 0.50	< 0.50	< 0.50	< 0.50	< 0.50
1,1,1,2,2-Tetrachloroethane	5	< 0.50	< 0.50	< 0.50	< 0.50	< 0.50
1,1,2-Trichloroethane	5	< 0.50	< 0.50	< 0.50	< 0.50	< 0.50
1,1-Dichloroethane	5	< 0.50	< 0.50	< 0.50	< 0.50	< 0.50
1,1-Dichloroethene	5	< 0.50	< 0.50	< 0.50	< 0.50	< 0.50
1,2-Dichloroethane	5	< 0.50	< 0.50	< 0.50	< 0.50	< 0.50
1,2-Dichloropropane	5	< 0.50	< 0.50	< 0.50	< 0.50	< 0.50
2-Butanone (MEK)	50	< 5.0	< 5.0	< 5.0	< 5.0	< 5.0
Methyl N-Butyl Ketone (2-Hexanone)	50	< 2.0	< 2.0	< 2.0	< 2.0	< 2.0
4-Methyl-2-Pentanone	50	< 2.0	< 2.0	< 2.0	< 2.0	< 2.0
Acetone	50	< 5.0	< 5.0	< 5.0	< 5.0	< 5.0
Benzene	1	< 0.50	< 0.50	< 0.50	< 0.50	< 0.50
Bromodichloromethane	50	< 0.50	< 0.50	< 0.50	< 0.50	< 0.50
Bromoform	50	< 0.50	< 0.50	< 0.50	< 0.50	< 0.50
Bromomethane	5	< 0.50	< 0.50	< 0.50	< 0.50	< 0.50
Carbon Disulfide	50	< 0.50	< 0.50	< 0.50	< 0.50	< 0.50
Carbon Tetrachloride	5	< 0.50	< 0.50	< 0.50	< 0.50	< 0.50
Chlorobenzene	5	< 0.50	< 0.50	< 0.50	< 0.50	< 0.50
Chloroethane	5	< 0.50	< 0.50	< 0.50	< 0.50	< 0.50
Chloroform	7	< 0.50	< 0.50	< 0.50	< 0.50	< 0.50
Chloromethane	5	< 0.50	< 0.50	< 0.50	< 0.50	< 0.50
cis-1,2-Dichloroethene	5	< 0.50	< 0.50	< 0.50	< 0.50	< 0.50
cis-1,3-Dichloropropene	5	< 0.50	< 0.50	< 0.50	< 0.50	< 0.50
Dibromochloromethane	5	< 0.50	< 0.50	< 0.50	< 0.50	< 0.50
Ethylbenzene	5	< 0.50	< 0.50	< 0.50	< 0.50	< 0.50
Methylene Chloride	5	< 0.50	< 0.50	< 0.50	< 0.50	< 0.50
Styrene (Monomer)	5	< 0.50	< 0.50	< 0.50	< 0.50	< 0.50
Tetrachloroethene	5	< 0.50	< 0.50	< 0.50	< 0.50	< 0.50
Toluene	5	< 0.50	< 0.50	< 0.50	< 0.50	< 0.50
trans-1,2-Dichloroethene	5	< 0.50	< 0.50	< 0.50	< 0.50	< 0.50
trans-1,3-Dichloropropene	5	< 0.50	< 0.50	< 0.50	< 0.50	< 0.50
Trichloroethene	5	< 0.50	< 0.50	< 0.50	< 0.50	< 0.50
Trichlorotrifluoroethane (Freon)	5	< 1.0	< 1.0	< 1.0	< 1.0	< 1.0
Vinyl chloride	2	< 0.50	< 0.50	< 0.50	< 0.50	< 0.50
o-Xylene	5	< 0.50	< 0.50	< 0.50	< 0.50	< 0.50
m,p-Xylene	5	< 0.50	< 0.50	< 0.50	< 0.50	< 0.50
TVOCs		0	0	0	0	0

Notes and abbreviations on last page.

Table 15
Concentrations of Volatile Organic Compounds
in Outpost Wells ⁽¹⁾, 2017
Operable Unit 2 Northrop Grumman Systems Corporation
Bethpage, New York

Constituents units in (ug/L)	Well ID: Sample ID: Sample Date:	BPOW 2-3 BPOW 2-3 2/22/2017	BPOW 2-3 BPOW 2-3 5/9/2017	BPOW 2-3 BPOW 2-3 9/20/2017	BPOW 2-3 BPOW 2-3 10/23/2017	BPOW 3-1 BPOW 3-1 7/6/2017
	NYSDEC SCG (ug/L) ⁽²⁾					
1,1,1-Trichloroethane	5	< 0.50	< 0.50	< 0.50 J	< 0.50	< 0.50
1,1,1,2,2-Tetrachloroethane	5	< 0.50	< 0.50	< 0.50 J	< 0.50	< 0.50
1,1,1,2-Trichloroethane	5	< 0.50	< 0.50	< 0.50 J	< 0.50	< 0.50
1,1-Dichloroethane	5	< 0.50	< 0.50	< 0.50 J	< 0.50	< 0.50
1,1-Dichloroethene	5	< 0.50	< 0.50	< 0.50	< 0.50	< 0.50
1,2-Dichloroethane	5	< 0.50	< 0.50	< 0.50	< 0.50	< 0.50
1,2-Dichloropropane	5	< 0.50	< 0.50	< 0.50 J	< 0.50	< 0.50
2-Butanone (MEK)	50	< 5.0	< 5.0	< 5.0	< 5.0	< 5.0
Methyl N-Butyl Ketone (2-Hexanone)	50	< 2.0	< 2.0	< 2.0	< 2.0	< 2.0
4-Methyl-2-Pentanone	50	< 2.0	< 2.0	< 2.0	< 2.0	< 2.0
Acetone	50	< 5.0	< 5.0	< 5.0	< 5.0	< 5.0
Benzene	1	< 0.50	< 0.50	< 0.50 J	< 0.50	< 0.50
Bromodichloromethane	50	< 0.50	< 0.50	< 0.50 J	< 0.50	< 0.50
Bromoform	50	< 0.50	< 0.50	< 0.50	< 0.50	< 0.50
Bromomethane	5	< 0.50	< 0.50	< 0.50	< 0.50	< 0.50
Carbon Disulfide	50	< 0.50	< 0.50	< 0.50	< 0.50	< 0.50
Carbon Tetrachloride	5	< 0.50	< 0.50	< 0.50	< 0.50	< 0.50
Chlorobenzene	5	< 0.50	< 0.50	< 0.50 J	< 0.50	< 0.50
Chloroethane	5	< 0.50	< 0.50	< 0.50	< 0.50	< 0.50
Chloroform	7	< 0.50	< 0.50	< 0.50 J	< 0.50	< 0.50
Chloromethane	5	< 0.50	< 0.50	< 0.50	< 0.50	< 0.50
cis-1,2-Dichloroethene	5	< 0.50	< 0.50	< 0.50 J	< 0.50	< 0.50
cis-1,3-Dichloropropene	5	< 0.50	< 0.50	< 0.50 J	< 0.50	< 0.50
Dibromochloromethane	5	< 0.50	< 0.50	< 0.50	< 0.50	< 0.50
Ethylbenzene	5	< 0.50	< 0.50	< 0.50 J	< 0.50	< 0.50
Methylene Chloride	5	< 0.50	< 0.50	< 0.50 J	< 0.50	< 0.50
Styrene (Monomer)	5	< 0.50	< 0.50	< 0.50	< 0.50	< 0.50
Tetrachloroethene	5	< 0.50	< 0.50	< 0.50	< 0.50	< 0.50
Toluene	5	< 0.50	< 0.50	< 0.50 J	< 0.50	< 0.50
trans-1,2-Dichloroethene	5	< 0.50	< 0.50	< 0.50 J	< 0.50	< 0.50
trans-1,3-Dichloropropene	5	< 0.50	< 0.50	< 0.50 J	< 0.50	< 0.50
Trichloroethene	5	< 0.50	< 0.50	< 0.50 J	< 0.50	< 0.50
Trichlorotrifluoroethane (Freon)	5	< 1.0	< 1.0	< 1.0	< 1.0	< 1.0
Vinyl chloride	2	< 0.50	< 0.50	< 0.50	< 0.50	< 0.50
o-Xylene	5	< 0.50	< 0.50	< 0.50	< 0.50	< 0.50
m,p-Xylene	5	< 0.50	< 0.50	< 0.50	< 0.50	< 0.50
TVOCs		0	0	0	0	0

Notes and abbreviations on last page.

Table 15
Concentrations of Volatile Organic Compounds
in Outpost Wells ⁽¹⁾, 2017
Operable Unit 2 Northrop Grumman Systems Corporation
Bethpage, New York

Constituents units in (ug/L)	Well ID: Sample ID: Sample Date:	BPOW 3-1 REP070617PP1 11/6/2017	BPOW 3-1 BPOW 3-1 11/6/2017	BPOW 3-2 BPOW 3-2 7/6/2017	BPOW 3-2 BPOW 3-2 11/14/2017	BPOW 3-3 BPOW 3-3 6/14/2017
	NYSDEC SCG (ug/L) ⁽²⁾					
1,1,1-Trichloroethane	5	< 0.50	< 0.50	< 0.50	< 0.50	< 0.50
1,1,1,2,2-Tetrachloroethane	5	< 0.50	< 0.50	< 0.50	< 0.50	< 0.50
1,1,2-Trichloroethane	5	< 0.50	< 0.50	< 0.50	< 0.50	< 0.50
1,1-Dichloroethane	5	< 0.50	< 0.50	< 0.50	< 0.50	< 0.50
1,1-Dichloroethene	5	< 0.50	< 0.50	< 0.50	< 0.50	< 0.50
1,2-Dichloroethane	5	< 0.50	< 0.50	< 0.50	< 0.50	< 0.50
1,2-Dichloropropane	5	< 0.50	< 0.50	< 0.50	< 0.50	< 0.50
2-Butanone (MEK)	50	< 5.0	< 5.0	< 5.0	< 5.0	< 5.0
Methyl N-Butyl Ketone (2-Hexanone)	50	< 2.0	< 2.0	< 2.0	< 2.0	< 2.0
4-Methyl-2-Pentanone	50	< 2.0	< 2.0	< 2.0	< 2.0	< 2.0
Acetone	50	< 5.0	< 5.0	< 5.0	< 5.0	< 5.0
Benzene	1	< 0.50	< 0.50	< 0.50	< 0.50	< 0.50
Bromodichloromethane	50	< 0.50	< 0.50	< 0.50	< 0.50	< 0.50
Bromoform	50	< 0.50	< 0.50	< 0.50	< 0.50	< 0.50
Bromomethane	5	< 0.50	< 0.50	< 0.50	< 0.50	< 0.50
Carbon Disulfide	50	< 0.50	< 0.50	< 0.50	< 0.50	< 0.50
Carbon Tetrachloride	5	< 0.50	< 0.50	< 0.50	< 0.50	< 0.50
Chlorobenzene	5	< 0.50	< 0.50	< 0.50	< 0.50	< 0.50
Chloroethane	5	< 0.50	< 0.50	< 0.50	< 0.50	< 0.50
Chloroform	7	< 0.50	< 0.50	< 0.50	< 0.50	< 0.50
Chloromethane	5	< 0.50	< 0.50	< 0.50	< 0.50	< 0.50
cis-1,2-Dichloroethene	5	< 0.50	< 0.50	< 0.50	< 0.50	< 0.50
cis-1,3-Dichloropropene	5	< 0.50	< 0.50	< 0.50	< 0.50	< 0.50
Dibromochloromethane	5	< 0.50	< 0.50	< 0.50	< 0.50	< 0.50
Ethylbenzene	5	< 0.50	< 0.50	< 0.50	< 0.50	< 0.50
Methylene Chloride	5	< 0.50	< 0.50	< 0.50	< 0.50	< 0.50
Styrene (Monomer)	5	< 0.50	< 0.50	< 0.50	< 0.50	< 0.50
Tetrachloroethene	5	< 0.50	< 0.50	< 0.50	< 0.50	< 0.50
Toluene	5	< 0.50	< 0.50	< 0.50	< 0.50	< 0.50
trans-1,2-Dichloroethene	5	< 0.50	< 0.50	< 0.50	< 0.50	< 0.50
trans-1,3-Dichloropropene	5	< 0.50	< 0.50	< 0.50	< 0.50	< 0.50
Trichloroethene	5	< 0.50	< 0.50	< 0.50	< 0.50	< 0.50
Trichlorotrifluoroethane (Freon)	5	< 1.0	< 1.0	< 1.0	< 1.0	< 1.0
Vinyl chloride	2	< 0.50	< 0.50	< 0.50	< 0.50	< 0.50
o-Xylene	5	< 0.50	< 0.50	< 0.50	< 0.50	< 0.50
m,p-Xylene	5	< 0.50	< 0.50	< 0.50	< 0.50	< 0.50
TVOCs		0	0	0	0	0

Notes and abbreviations on last page.

Table 15
Concentrations of Volatile Organic Compounds
in Outpost Wells ⁽¹⁾, 2017
Operable Unit 2 Northrop Grumman Systems Corporation
Bethpage, New York

Constituents units in (ug/L)	Well ID: Sample ID: Sample Date:	BPOW 3-3 BPOW 3-3 11/10/2017	BPOW 3-4 BPOW 3-4 6/14/2017	BPOW 3-4 BPOW 3-4 11/10/2017	BPOW 4-1R BPOW 4-1R 5/26/2017	BPOW 4-1R BPOW 4-1R 11/6/2017
	NYSDEC SCG (ug/L) ⁽²⁾					
1,1,1-Trichloroethane	5	< 0.50	0.13 J	0.26 J	0.18 J	< 0.50
1,1,1,2-Tetrachloroethane	5	< 0.50	< 0.50	< 0.50	< 0.50	< 0.50
1,1,2-Trichloroethane	5	< 0.50	0.79	1.4	< 0.50	< 0.50
1,1-Dichloroethane	5	< 0.50	0.21 J	0.43 J	< 0.50	< 0.50
1,1-Dichloroethene	5	< 0.50	1.6	3.2	1.0	0.28 J
1,2-Dichloroethane	5	< 0.50	< 0.50	< 0.50	< 0.50	< 0.50
1,2-Dichloropropane	5	< 0.50	< 0.50	< 0.50	< 0.50	< 0.50
2-Butanone (MEK)	50	< 5.0	< 5.0	< 5.0	< 5.0	< 5.0
Methyl N-Butyl Ketone (2-Hexanone)	50	< 2.0	< 2.0	< 2.0	< 2.0	< 2.0
4-Methyl-2-Pentanone	50	< 2.0	< 2.0	< 2.0	< 2.0	< 2.0
Acetone	50	< 5.0	< 5.0	< 5.0	< 5.0	< 5.0
Benzene	1	< 0.50	< 0.50	< 0.50	< 0.50	< 0.50
Bromodichloromethane	50	< 0.50	< 0.50	< 0.50	< 0.50	< 0.50
Bromoform	50	< 0.50	< 0.50	< 0.50	< 0.50	< 0.50
Bromomethane	5	< 0.50	< 0.50	< 0.50	< 0.50	< 0.50
Carbon Disulfide	50	< 0.50	< 0.50	< 0.50	< 0.50	< 0.50
Carbon Tetrachloride	5	< 0.50	0.87	1.3	0.33 J	< 0.50
Chlorobenzene	5	< 0.50	< 0.50	< 0.50	< 0.50	< 0.50
Chloroethane	5	< 0.50	< 0.50	< 0.50	< 0.50	< 0.50
Chloroform	7	< 0.50	1.4	2.5	0.81	0.61
Chloromethane	5	< 0.50	< 0.50	< 0.50	< 0.50	< 0.50
cis-1,2-Dichloroethene	5	< 0.50	1.2	1.8	< 0.50	< 0.50
cis-1,3-Dichloropropene	5	< 0.50	< 0.50	< 0.50	< 0.50	< 0.50
Dibromochloromethane	5	< 0.50	< 0.50	< 0.50	< 0.50	< 0.50
Ethylbenzene	5	< 0.50	< 0.50	< 0.50	< 0.50	< 0.50
Methylene Chloride	5	< 0.50	< 0.50	< 0.50	< 0.50	< 0.50
Styrene (Monomer)	5	< 0.50	< 0.50	< 0.50	< 0.50	< 0.50
Tetrachloroethene	5	< 0.50	< 0.50	< 0.50	< 0.50	< 0.50
Toluene	5	< 0.50	< 0.50	< 0.50	< 0.50	< 0.50
trans-1,2-Dichloroethene	5	< 0.50	< 0.50	< 0.50	< 0.50	< 0.50
trans-1,3-Dichloropropene	5	< 0.50	< 0.50	< 0.50	< 0.50	< 0.50
Trichloroethene	5	< 0.50	77.3	106 D	0.84	0.28 J
Trichlorotrifluoroethane (Freon)	5	< 1.0	1.2	2.7	26.6	8.7
Vinyl chloride	2	< 0.50	< 0.50	< 0.50	< 0.50	< 0.50
o-Xylene	5	< 0.50	< 0.50	< 0.50	< 0.50	< 0.50
m,p-Xylene	5	< 0.50	< 0.50	< 0.50	< 0.50	< 0.50
TVOCs		0	85	120	29	9.9

Notes and abbreviations on last page.

Table 15
Concentrations of Volatile Organic Compounds
in Outpost Wells ⁽¹⁾, 2017
Operable Unit 2 Northrop Grumman Systems Corporation
Bethpage, New York

Constituents units in (ug/L)	Well ID: Sample ID: Sample Date:	BPOW 4-1R REP110617AR1 11/6/2017	BPOW 4-2R BPOW 4-2R 6/20/2017	BPOW 4-2R BPOW 4-2R 11/7/2017
	NYSDEC SCG (ug/L) ⁽²⁾			
1,1,1-Trichloroethane	5	< 0.50	< 0.50	< 0.50
1,1,1,2,2-Tetrachloroethane	5	< 0.50	< 0.50	< 0.50
1,1,2-Trichloroethane	5	< 0.50	< 0.50	< 0.50
1,1-Dichloroethane	5	< 0.50	< 0.50	< 0.50
1,1-Dichloroethene	5	0.32 J	< 0.50	0.25 J
1,2-Dichloroethane	5	< 0.50	< 0.50	< 0.50
1,2-Dichloropropane	5	< 0.50	< 0.50	< 0.50
2-Butanone (MEK)	50	< 5.0	< 5.0	< 5.0
Methyl N-Butyl Ketone (2-Hexanone)	50	< 2.0	< 2.0	< 2.0
4-Methyl-2-Pentanone	50	< 2.0	< 2.0	< 2.0
Acetone	50	< 5.0	< 5.0	< 5.0
Benzene	1	< 0.50	< 0.50	< 0.50
Bromodichloromethane	50	< 0.50	< 0.50	< 0.50
Bromoform	50	< 0.50	< 0.50	< 0.50
Bromomethane	5	< 0.50	< 0.50	< 0.50
Carbon Disulfide	50	< 0.50	< 0.50	< 0.50
Carbon Tetrachloride	5	< 0.50	< 0.50	< 0.50
Chlorobenzene	5	< 0.50	< 0.50	< 0.50
Chloroethane	5	< 0.50	< 0.50	< 0.50
Chloroform	7	0.69	< 0.50	< 0.50
Chloromethane	5	< 0.50	< 0.50	< 0.50
cis-1,2-Dichloroethene	5	< 0.50	< 0.50	< 0.50
cis-1,3-Dichloropropene	5	< 0.50	< 0.50	< 0.50
Dibromochloromethane	5	< 0.50	< 0.50	< 0.50
Ethylbenzene	5	< 0.50	< 0.50	< 0.50
Methylene Chloride	5	< 0.50	< 0.50	< 0.50
Styrene (Monomer)	5	< 0.50	< 0.50	< 0.50
Tetrachloroethene	5	< 0.50	< 0.50	< 0.50
Toluene	5	< 0.50	< 0.50	< 0.50
trans-1,2-Dichloroethene	5	< 0.50	< 0.50	< 0.50
trans-1,3-Dichloropropene	5	< 0.50	< 0.50	< 0.50
Trichloroethene	5	0.25 J	0.60	0.92
Trichlorotrifluoroethane (Freon)	5	10.1	2.5	5.8
Vinyl chloride	2	< 0.50	< 0.50	< 0.50
o-Xylene	5	< 0.50	< 0.50	< 0.50
m,p-Xylene	5	< 0.50	< 0.50	< 0.50
TVOCs		11	3.1	7.0

Notes and abbreviations on last page.

Table 15
Concentrations of Volatile Organic Compounds
in Outpost Wells ⁽¹⁾, 2017
Operable Unit 2 Northrop Grumman Systems Corporation
Bethpage, New York

Notes and Abbreviations:

- (1) These outpost wells have been recently repurposed for use as plume monitoring wells per the June 2015 Groundwater Monitoring Plan Addendum (ARCADIS of New York, Inc., 2015) as conditionally approved by the NYSDEC (August 25, 2015). Therefore, TVOC trigger levels that may have been previously established are no longer shown.
- (2) Standards Criteria and Guidance (SCGs) values based on the Groundwater Feasibility Study Report (ARCADIS Geraghty & Miller, Inc. 2000) are based on the NYSDEC TOGs (NYSDEC 1998); most stringent values listed.
- (3) The NAVY abandoned original Wells BPOW4-1 and BPOW4-2 and installed replacement Wells BPOW4-1R and BPOW4-2R between August, 2014 and October, 2014.

Samples were analyzed for VOCs using USEPA Method 524.2

Results for the program are validated at 20% frequency, per protocols specified in OU2 Groundwater Monitoring Plan (Arcadis 2016)

TVOCs are rounded to two significant figures.

Bold value indicates constituent detected.

	Compound detected in exceedance of NYSDEC SCG Criteria
D	Value from Secondary Dilution
NYSDEC	New York State Department of Environmental Conservation
TVOCs	Total Volatile Organic Compounds
TOGs	Technical and Operational Guidance Series
USEPA	United States Environmental Protection Agency
VOC	Volatile Organic Compounds
µg/L	micrograms per liter
<0.5	Compound not detected above its laboratory quantification limit.
SCG	Standards, Criteria and Guidance Value
J	Value is estimated concentration

Table 16
Concentrations of Metals in Groundwater
Monitoring Wells ⁽¹⁾, Operable Unit 2, 2017
Northrop Grumman Systems Corporation,
Bethpage, New York.

Constituent (units in ug/L)	Well Id:	GM-15SR	GM-15SR	GM-78I	GM-78S	MW-02GF	MW-02GF	N-10631	N-10631	N-10631	PLT1 MW-04
	Sample ID:	GM-15SR	GM-15SR	GM-78I	GM-78S	MW-02GF	MW-02GF	N-10631	N-10631	REP111317DC1	PLT1 MW-04
	Sample Date:	6/28/2017	11/2/2017	5/5/17	6/22/2017	6/29/2017	11/2/2017	6/23/2017	11/13/2017	11/13/2017	6/27/2017
	NYSDEC SCGs (ug/L) ⁽¹⁾										
Cadmium	5	--	--	<3.0	<3.0	<3.0	<3.0	6.2	4	3.6	--
Cadmium (Dissolved)	5	--	--	<3.0	<3.0	<3.0	<3.0	5.2	<3.0	<3.0	--
Chromium	50	701	429	<10	<10	27.9	30.5	29.1	29.1	26.4	<10
Chromium (Dissolved)	50	679	445	<10	<10	27.4	28.5	18.8	<10	<10	<10

See Notes and Abbreviations on Last Page



Table 16
Concentrations of Metals in Groundwater
Monitoring Wells ⁽¹⁾, Operable Unit 2, 2017
Northrop Grumman Systems Corporation,
Bethpage, New York.

Constituent (units in ug/L)	Well Id:	PLT1 MW-04	PLT1 MW-05	PLT1 MW-05	PLT1 MW-06	PLT1 MW-06	PLT1 MW-06	PLT1 MW-06
	Sample ID:	PLT1 MW-04	PLT1 MW-05	PLT1 MW-05	PLT1 MW-06	REP062117AD1	PLT1 MW-06	REP102017DC1
	Sample Date:	10/20/2017	6/27/2017	10/20/2017	6/21/2017	6/21/2017	10/20/2017	10/20/2017
	NYSDEC SCGs (ug/L) ⁽¹⁾							
Cadmium	5	--	--	--	--	--	--	--
Cadmium (Dissolved)	5	--	--	--	--	--	--	--
Chromium	50	<10	586	700	189	187	179	171
Chromium (Dissolved)	50	<10	583	670	188	191	186	182

Notes and Abbreviations:

- (1) Monitoring Well MW-1GF could not be sampled during 2017 due to access issues. Monitoring Well MW-1GF is located upgradient of former Northrop Grumman Plant 2. Northrop Grumman will work with current property owner to resolve access issues.
- (2) Standards, Criteria, and Guidance (SCG) values based on documents referenced in the Groundwater Feasibility Study Report (ARCADIS Geraghty & Miller, Inc. 2000) that are based on the NYSDEC TOGs (NYSDEC 1998); most stringent value listed.

Samples analyzed for total/dissolved Cadmium and Chromium using USEPA Method 6010C.
 Results for the program are validated at 20% frequency, per protocols specified in OU2 Groundwater Monitoring Plan (Arcadis 2016)
 Bold value indicates a detection

- Compound detected in exceedance of NYSDEC SCG Criteria
- NYSDEC New York State Department of Environmental Conservation
- SCG Standards, Criteria, and Guidance
- TOGs Technical Operational and Guidance Series
- µg/L Micrograms per liter
- Not analyzed
- < 3.0 Compound not detected above its laboratory quantification limit
- REP Blind duplicate sample

Table 17
Concentrations of 1,4-Dioxane in Monitoring Wells
and Remedial Wells,
Operable Unit 2, Northrop Grumman Systems Corporation,
Bethpage, New York.

	Constituent	(units in ug/L)	1,4-Dioxane
Well ID ⁽¹⁾ :	Sample ID:	Sample Date:	
FW-03	FW-03	4/20/2017	1.04
GM-13D	GM-13D	4/17/2017	4.85
GM-15SR	GM-15SR	6/28/2017	<0.200
GM-15SR	GM-15SR	11/2/2017	0.112 J
GM-15I	GM-15I	6/28/2017	0.415
GM-15I	GM-15I	11/2/2017	0.352
GM-15D	GM-15D	6/28/2017	4.14
GM-15D	GM-15D	11/2/2017	0.145
GM-15D2	GM-15D2	6/28/2017	<0.200
GM-15D2	GM-15D2	11/2/2017	3.91
GM-17I	GM-17I	5/2/2017	9.18
GM-17I	GM-17I	11/1/2017	8.56
GM-17D	GM-17D	5/2/2017	11.5
GM-17D	GM-17D	11/1/2017	9.97
GM-18I	GM-18I	7/11/2017	13.70
GM-18I	GM-18I	10/31/2017	11.1
GM-18D	GM-18D	4/21/2017	15.20
GM-18D	GM-18D	10/31/2017	14.00
GM-20I	GM-20I	4/25/2017	6.51
GM-20D	GM-20D	4/25/2017	6.24
GM-21S	GM-21S	6/21/2017	4.55
GM-21I	GM-21I	4/26/2017	6.73
GM-21D	GM-21D	5/3/2017	5.66
GM-21D2	GM-21D2	5/19/2017	5.47 J
GM-21D2	GM-21D2	10/26/2017	5.52
GM-33D2	GM-33D2	6/12/2017	14.3
GM-33D2	GM-33D2	10/19/2017	14.9
GM-34D	GM-34D	6/26/2017	24.4
GM-34D	GM-34D	10/31/2017	19.7
GM-34D2	GM-34D2	6/26/2017	15.3
GM-34D2	GM-34D2	10/31/2017	18.1
GM-35D2	GM-35D2	4/24/2017	9.61
GM-35D2	GM-35D2	10/30/2017	11.1
GM-36D	GM-36D	6/19/2017	2.07
GM-36D2	GM-36D2	7/11/2017	3.97
GM-37D	GM-37D	7/11/2017	0.693
GM-37D	REP071117AD1	7/11/2017	0.651
GM-37D2	GM-37D2	7/5/2017	1.26

See Notes and Abbreviations on last page

Table 17
Concentrations of 1,4-Dioxane in Monitoring Wells
and Remedial Wells,
Operable Unit 2, Northrop Grumman Systems Corporation,
Bethpage, New York.

	Constituent	(units in ug/L)	1,4-Dioxane
Well ID ⁽¹⁾ :	Sample ID:	Sample Date:	
GM-38D	GM-38D	5/1/2017	3.64
GM-38D	REP050117AD1	5/1/2017	4.52
GM-38D	GM-38D	10/24/2017	4.1
GM-38D2	GM-38D2	5/2/2017	4.24
GM-38D2	GM-38D2	10/24/2017	4.87 J
GM-39DA	GM-39DA	5/3/2017	5.42
GM-39DA	GM-39DA	11/1/2017	6.94
GM-39DB	GM-39DB	5/3/2017	5.88
GM-39DB	GM-39DB	11/1/2017	5.87
GM-70D2	GM-70D2	4/24/2017	8.49
GM-71D2	GM-71D2	4/26/2017	3.13
GM-73D	GM-73D	6/15/2017	5.38
GM-73D	GM-73D	10/27/2017	5.83
GM-73D2	GM-73D2	4/14/2017	3.2
GM-73D2	GM-73D2	10/27/2017	4.18
GM-73D3	GM-73D3	6/29/2017	0.976
GM-73D3	GM-73D3	10/27/2017	1.15
GM-74I	GM-74I	5/2/2017	4.95
GM-74I	GM-74I	10/25/2017	6.1
GM-74D	GM-74D	5/2/2017	6.77
GM-74D	GM-74D	10/25/2017	6.6
GM-74D2	GM-74D2	4/14/2017	4.13
GM-74D2	GM-74D2	10/25/2017	4.07
GM-74D3	GM-74D3	7/10/2017	3.29
GM-74D3	GM-74D3	10/25/2017	2.95
GM-75D2	GM-75D2	6/12/2017	8.18
GM-75D2	GM-75D2	10/19/2017	9.51
GM-78S	GM-78S	6/22/2017	4.65
GM-78I	GM-78I	5/5/2017	5.17
GM-78D	GM-78D	5/4/2017	10.8
GM-78D	GM-78D	11/1/2017	11.7
GM-78D2	GM-78D2	5/4/2017	14.4
GM-78D2	GM-78D2	11/1/2017	12.3
GM-79I	GM-79I	6/28/2017	5.79
GM-79I	GM-79I	10/30/2017	8.56
GM-79D	GM-79D	6/28/2017	5.85
GM-79D	GM-79D	10/30/2017	8.71
HN-24I	HN-24I	4/20/2017	4.48
HN-40S	HN-40S	4/19/2017	0.122 J
HN-40I	HN-40I	4/19/2017	0.101 J

See Notes and Abbreviations on last page

Table 17
Concentrations of 1,4-Dioxane in Monitoring Wells
and Remedial Wells,
Operable Unit 2, Northrop Grumman Systems Corporation,
Bethpage, New York.

	Constituent	(units in ug/L)	1,4-Dioxane
Well ID ⁽¹⁾ :	Sample ID:	Sample Date:	
HN-42S	HN-42S	6/22/2017	<0.200
HN-42I	HN-42I	4/19/2017	0.69
MW-01GF ⁽²⁾	MW-01GF	NA	NA
MW-01GF ⁽²⁾	MW-01GF	NA	NA
MW-02GF	MW-02GF	6/29/2017	5.13
MW-02GF	MW-02GF	11/2/2017	1.92
MW-3-1	MW-3-1	7/7/2017	15.1
MW-3-1	MW-3-1	11/3/2017	13.3
N-10624	N-10624	6/21/2017	4.04
N-10627	N-10627	6/21/2017	5.65
N-10631	N-10631	6/23/2017	6.37 J
N-10631	N-10631	11/13/2017	6.97
N-10631	REP111317DC1	11/13/2017	8.49
PLT1 MW-04	PLT1 MW-04	6/27/2017	0.104 J
PLT1 MW-04	PLT1 MW-04	10/20/2017	0.305
PLT1 MW-05	PLT1 MW-05	6/27/2017	0.241
PLT1 MW-05	PLT1 MW-05	10/20/2017	0.173 J
PLT1 MW-06	PLT1 MW-06	6/21/2017	< 0.200
PLT1 MW-06	PLT1 MW-06	10/20/2017	<0.200
PLT1 MW-06	REP10202017DC1	10/20/2017	<0.200
BPOW 1-1	BPOW 1-1	6/19/2017	0.100 J
BPOW 1-1	BPOW 1-1	11/3/2017	0.115 J
BPOW 1-2	BPOW 1-2	6/13/2017	0.204
BPOW 1-2	BPOW 1-2	11/3/2017	0.122 J
BPOW 1-3	BPOW 1-3	6/13/2017	0.312
BPOW 1-3	BPOW 1-3	11/3/2017	0.115 J
BPOW 1-4	BPOW 1-4	6/12/2017	<0.200
BPOW 1-4	BPOW 1-4	11/8/2017	<0.200
BPOW 1-5	BPOW 1-5	6/12/2017	<0.200
BPOW 1-5	BPOW 1-5	11/8/2017	<0.200
BPOW 1-6	BPOW 1-6	6/27/2017	<0.200
BPOW 1-6	BPOW 1-6	11/8/2017	<0.200
BPOW 2-1	BPOW 2-1	2/21/2017	1.32
BPOW 2-1	BPOW 2-1	5/10/2017	1.33
BPOW 2-1	BPOW 2-1	9/12/2017	1.38
BPOW 2-1	BPOW 2-1	10/23/2017	1.48
BPOW 2-2	BPOW 2-2	2/21/2017	0.333
BPOW 2-2	BPOW 2-2	5/10/2017	0.326
BPOW 2-2	BPOW 2-2	9/12/2017	0.293
BPOW 2-2	BPOW 2-2	10/23/2017	0.313
BPOW 2-3	BPOW 2-3	2/22/2017	3.68
BPOW 2-3	BPOW 2-3	5/9/2017	3.77
BPOW 2-3	BPOW 2-3	9/20/2017	3.98
BPOW 2-3	BPOW 2-3	10/23/2017	3.81

See Notes and Abbreviations on last page

Table 17
Concentrations of 1,4-Dioxane in Monitoring Wells
and Remedial Wells,
Operable Unit 2, Northrop Grumman Systems Corporation,
Bethpage, New York.

	Constituent	(units in ug/L)	1,4-Dioxane
Well ID ⁽¹⁾ :	Sample ID:	Sample Date:	
BPOW 3-1	BPOW 3-1	7/6/2017	0.811
BPOW 3-1	REP070617PP1	7/6/2017	0.794
BPOW 3-1	BPOW 3-1	11/6/2017	0.693
BPOW 3-2	BPOW 3-2	7/6/2017	3.49
BPOW 3-2	BPOW 3-3	11/14/2017	4.48
BPOW 3-3	BPOW 3-3	6/14/2017	5.63 J
BPOW 3-3	BPOW 3-3	11/10/2017	4.98
BPOW 3-4	BPOW 3-4	6/14/2017	4.43
BPOW 3-4	BPOW 3-4	11/10/2017	2.52
BPOW 4-1R ⁽³⁾	BPOW 4-1R	5/26/2017	2.64
BPOW 4-1R ⁽³⁾	BPOW 4-1R	11/6/2017	1.87
BPOW4-1R	REP110617AR1	11/6/2017	1.78
BPOW 4-2R ⁽³⁾	BPOW 4-2R	6/20/2017	0.425
BPOW 4-2R ⁽³⁾	BPOW 4-2R	11/7/2017	0.515
Well 1	Well 1	2/22/2017	8.91
Well 1	Well 1	6/27/2017	9.78
Well 1	Well 1	9/12/2017	9.35
Well 1	Well 1	12/13/2017	9.09
Well 3R	Well 3R	2/14/2017	16.4
Well 3R	Well 3R	6/27/2017	15.8
Well 3R	Well 3R	9/12/2017	14.9
Well 3R	Well 3R	12/13/2017	16.8
Well 17	Well 17	2/14/2017	8.74
Well 17	Well 17	6/29/2017	7.48
Well 17	Well 17	9/12/2017	8.51
Well 17	REP-091217-MG-1	9/12/2017	8.21
Well 17	Well 17	12/13/2017	10.5
Well 17	REP-121317-MG-1	12/13/2017	11.2
Well 18	WELL 18	2/14/2017	7.24
Well 18	REP-021417-SN-1	2/14/2017	6.67
Well 18	WELL 18	6/27/2017	7.06
Well 18	REP-062417-JB-1	6/27/2017	7.03
Well 18	WELL 18	9/12/2017 ⁽⁴⁾	7.44
Well 18	WELL 18	12/13/2017	6.86
Well 19	Well 19	2/14/2017	6.34
Well 19	Well 19	6/27/2017	5.59
Well 19	Well 19	9/12/2017 ⁽⁴⁾	5.53
Well 19	Well 19	12/13/2017	6.3

Notes and Abbreviations:

- (1) All samples analyzed for 1,4-Dioxane using USEPA Method 522
- (2) MW-1GF could not be sampled due to accessibility issues (well location was paved over)
- (3) The NAVY abandoned original Wells BPOW4-1 and BPOW4-2 and installed replacement Wells BPOW4-1R and BPOW4-2R between August, 2014 and October, 2014.

Results are validated at 20% frequency, per protocols specified in OU2 Groundwater Monitoring Plan (ARCADIS 2016).

Bold value indicates constituent detected.

- REP Blind Duplicate Sample
- USEPA United States Environmental Protection Agency
- µg/L micrograms per liter
- <0.20 Compound not detected above its laboratory quantification limit.
- J Value is estimated concentration

Table 18
Comparison of Fourth Quarter 2017 Verical Hydraulic Gradients
to Model-Predicted Gradients, Operable Unit 2,
Northrop Grumman Systems Corporation,
Bethpage, New York

Well Pair	Well Screen Midpoint Elevation (ft msl)	Water-Level Elevation (ft msl)	Vertical Gradient ⁽¹⁾ (ft/ft) x 10 ⁻³	Model-Predicted, OU2 Steady-State Vertical Gradient ⁽²⁾ (ft/ft) x 10 ⁻³	Change Compared to Model-Predicted, Steady-State Vertical Gradient
Shallow-Shallow Wells ⁽³⁾					
GM-17SR	50.79	70.07			
GM-17I	5.83	70.08	-0.22	2.67	-2.89
GM-78S	39.94	60.26			
GM-78I	5.56	60.06	5.82	1.75	4.07
Shallow-Intermediate Wells ⁽³⁾					
GM-19S	59.36	62.16			
GM-19I	-25.14	61.71	5.33	0.47	4.86
GM-21S	40.81	63.01			
GM-21I	-29.28	63.62	-8.70	5.99	-14.69
Shallow-Deep Wells ⁽³⁾					
GM-17I	5.83	70.08			
GM-17D	-172.32	63.73	35.64	20.43	15.21
GM-18I	9.03	63.48			
GM-18D	-186.12	60.53	15.12	19.16	-4.04
GM-20I	3.88	60.83			
GM-20D	-117.08	60.07	6.28	26.70	-20.42
GM-21I	-29.28	63.62			
GM-21D	-177.34	58.36	35.53	42.55	-7.02
GM-74I	8.42	62.34			
GM-74D	-192.57	58.21	20.55	35.13	-14.58
Deep-Deep 2 Wells ⁽³⁾					
GM-15D	-227.34	58.60			
GM-15D2	-436.20	56.58	9.67	-16.32	25.99
GM-18D	-186.12	60.53			
GM-33D2	-403.15	54.42	28.15	49.49	-21.34
GM-21D	-177.34	58.36			
GM-21D2	-416.60	53.57	20.02	21.27	-1.25
GM-39D _A	-169.77	58.33			
GM-39D _B	-312.92	58.78	-3.14	25.92	-29.06
GM-74D	-192.57	58.21			
GM-74D2	-444.64	52.41	23.01	37.81	-14.80

See Notes and Abbreviations on last page

Table 18
Comparison of Fourth Quarter 2017 Verical Hydraulic Gradients
to Model-Predicted Gradients, Operable Unit 2,
Northrop Grumman Systems Corporation,
Bethpage, New York

Well Pair	Well Screen Midpoint Elevation (ft msl)	Water-Level Elevation (ft msl)	Vertical Gradient ⁽¹⁾ (ft/ft) x 10 ⁻³	Model-Predicted, OU2 Steady-State Vertical Gradient ⁽²⁾ (ft/ft) x 10 ⁻³	Change Compared to Model-Predicted, Steady-State Vertical Gradient
Deep 2-Deep 2 Wells ⁽³⁾					
GM-73D	-301.13	57.42			
GM-73D2	-437.38	55.52	13.94	23.85	-9.91
Deep 2-Deep 3 Wells ⁽³⁾					
GM-74D2	-444.64	52.41			
GM-74D3	-527.42	53.94	-18.48	-37.49	19.01
GM-73D	-301.13	57.42			
GM-73D3	-537.86	54.78	11.15	10.12	1.03

Notes and Abbreviations:

- (1) Vertical hydraulic gradients are calculated as follows:

$$\frac{(\text{Water-Level Elevation}_1 - \text{Water-Level Elevation}_2)}{(\text{Screen Midpoint Elevation}_1 - \text{Screen Midpoint Elevation}_2)}$$
₁ - Shallower well of pairing
₂ - Deeper well of pairing
 A positive "+" gradient value indicates a downward hydraulic gradient.
 A negative "-" gradient value indicates an upward hydraulic gradient.
- (2) The 2003 expanded model with subsequent 2004/2005 modifications to the ONCT System was used to calculate the Steady State Vertical Gradient.
- (3) Well identification (e.g., GM-73D) does not necessarily designate the actual hydrogeologic zone. Determination of the hydrogeologic zone is based on the well screen interval and the regional model layering.
- ft msl feet relative to mean sea level
 OU2 Operable Unit 2
 ONCT On-Site Containment

Table 19A
Concentrations of Volatile Organic Compounds and
1,4-Dioxane in Blank Samples,
Operable Unit 2, Northrop Grumman Systems Corporation,
Bethpage, New York

Constituents (units in g/L)	Analytical Method Sample ID: Sample Date:	QA/QC	QA/QC	QA/QC	QA/QC	QA/QC	QA/QC	QA/QC
		USEPA Method 8260 TB041417AR1 4/14/2017	USEPA Method 8260 TB041717AD01 4/17/2017	USEPA Method 8260 TB041917AD1 4/19/2017	USEPA Method 522 FB041917AD1 4/19/2017	USEPA Method 8260 FB041917AD1 4/19/2017	USEPA Method 8260 TB042017AD1 4/20/2017	USEPA Method 8260 FB042017AD1 4/20/2017
1,1,1-Trichloroethane		< 1.0	< 1.0	< 1.0	--	< 1.0	< 1.0	< 1.0
1,1,2,2-Tetrachloroethane		< 1.0	< 1.0	< 1.0	--	< 1.0	< 1.0	< 1.0
1,1,2-trichloro-1,2,2-trifluoroethane		< 5.0	< 5.0	< 5.0	--	< 5.0	< 5.0	< 5.0
1,1,2-Trichloroethane		< 1.0	< 1.0	< 1.0	--	< 1.0	< 1.0	< 1.0
1,1-Dichloroethane		< 1.0	< 1.0	< 1.0	--	< 1.0	< 1.0	< 1.0
1,1-Dichloroethene		< 1.0	< 1.0	< 1.0	--	< 1.0	< 1.0	< 1.0
1,2-Dichloroethane		< 1.0	< 1.0	< 1.0	--	< 1.0	< 1.0	< 1.0
1,2-Dichloropropane		< 1.0	< 1.0	< 1.0	--	< 1.0	< 1.0	< 1.0
2-Butanone (MEK)		< 10	< 10	< 10	--	< 10	< 10	< 10
4-Methyl-2-Pentanone		< 5.0	< 5.0	< 5.0	--	< 5.0	< 5.0	< 5.0
Acetone		< 10	< 10	< 10	--	< 10	< 10	< 10
Benzene		< 0.50	< 0.50	< 0.50	--	< 0.50	< 0.50	< 0.50
Bromodichloromethane		< 1.0	< 1.0	< 1.0	--	< 1.0	< 1.0	< 1.0
Bromoform		< 1.0	< 1.0	< 1.0	--	< 1.0	< 1.0	< 1.0
Bromomethane		< 2.0	< 2.0	< 2.0	--	< 2.0	< 2.0	< 2.0
Carbon Disulfide		< 2.0	< 2.0	< 2.0	--	< 2.0	< 2.0	< 2.0
Carbon Tetrachloride		< 1.0	< 1.0	< 1.0	--	< 1.0	< 1.0	< 1.0
Chlorobenzene		< 1.0	< 1.0	< 1.0	--	< 1.0	< 1.0	< 1.0
Chlorodibromomethane		< 1.0	< 1.0	< 1.0	--	< 1.0	< 1.0	< 1.0
Chloroethane		< 1.0	< 1.0	< 1.0	--	< 1.0	< 1.0	< 1.0
Chloroform		< 1.0	< 1.0	< 1.0	--	< 1.0	< 1.0	< 1.0
Chloromethane		< 1.0	< 1.0	< 1.0	--	< 1.0	< 1.0	< 1.0
cis-1,2-Dichloroethene		< 1.0	< 1.0	< 1.0	--	< 1.0	< 1.0	< 1.0
cis-1,3-Dichloropropene		< 1.0	< 1.0	< 1.0	--	< 1.0	< 1.0	< 1.0
Ethylbenzene		< 1.0	< 1.0	< 1.0	--	< 1.0	< 1.0	< 1.0
Methyl N-Butyl Ketone (2-Hexanone)		< 5.0	< 5.0	< 5.0	--	< 5.0	< 5.0	< 5.0
Methylene Chloride		< 2.0	< 2.0	< 2.0	--	< 2.0	< 2.0	< 2.0
Styrene (Monomer)		< 1.0	< 1.0	< 1.0	--	< 1.0	< 1.0	< 1.0
Tetrachloroethene		< 1.0	< 1.0	< 1.0	--	< 1.0	< 1.0	< 1.0
Toluene		< 1.0	< 1.0	< 1.0	--	< 1.0	< 1.0	< 1.0
trans-1,2-Dichloroethene		< 1.0	< 1.0	< 1.0	--	< 1.0	< 1.0	< 1.0
trans-1,3-Dichloropropene		< 1.0	< 1.0	< 1.0	--	< 1.0	< 1.0	< 1.0
Trichloroethene		< 1.0	< 1.0	< 1.0	--	< 1.0	< 1.0	< 1.0
Vinyl chloride		< 1.0	< 1.0	< 1.0	--	< 1.0	< 1.0	< 1.0
Xylene-o		< 1.0	< 1.0	< 1.0	--	< 1.0	< 1.0	< 1.0
Xylenes- m,p		< 1.0	< 1.0	< 1.0	--	< 1.0	< 1.0	< 1.0
Total VOCs		0	0	0	0	0	0	0
1,4-Dioxane		--	--	--	< 0.200	--	--	--

See Notes and Abbreviations on last page

Table 19A
Concentrations of Volatile Organic Compounds and
1,4-Dioxane in Blank Samples,
Operable Unit 2, Northrop Grumman Systems Corporation,
Bethpage, New York

Constituents (units in g/L)	Analytical Method Sample ID: Sample Date:	QA/QC	QA/QC	QA/QC	QA/QC	QA/QC	QA/QC	QA/QC
		USEPA Method 522 FB-042017AD1 4/20/2017	USEPA Method 8260 TB042117AD1 4/21/2017	USEPA Method 8260 TB042417AD1 4/24/2017	USEPA Method 8260 TB042517AD1 4/25/2017	USEPA Method 8260 TB042617AD1 4/26/2017	USEPA Method 8260 TB050117AD1 5/1/2017	USEPA Method 8260 TB050217AR1 5/2/2017
1,1,1-Trichloroethane		--	< 1.0	< 1.0	< 1.0	< 1.0	< 1.0	< 1.0
1,1,2,2-Tetrachloroethane		--	< 1.0	< 1.0	< 1.0	< 1.0	< 1.0	< 1.0
1,1,2-trichloro-1,2,2-trifluoroethane		--	< 5.0	< 5.0	< 5.0	< 5.0	< 5.0	< 5.0
1,1,2-Trichloroethane		--	< 1.0	< 1.0	< 1.0	< 1.0	< 1.0	< 1.0
1,1-Dichloroethane		--	< 1.0	< 1.0	< 1.0	< 1.0	< 1.0	< 1.0
1,1-Dichloroethene		--	< 1.0	< 1.0	< 1.0	< 1.0	< 1.0	< 1.0
1,2-Dichloroethane		--	< 1.0	< 1.0	< 1.0	< 1.0	< 1.0	< 1.0
1,2-Dichloropropane		--	< 1.0	< 1.0	< 1.0	< 1.0	< 1.0	< 1.0
2-Butanone (MEK)		--	< 10	< 10	< 10	< 10	< 10	< 10
4-Methyl-2-Pentanone		--	< 5.0	< 5.0	< 5.0	< 5.0	< 5.0	< 5.0
Acetone		--	< 10	< 10	< 10	< 10	< 10	< 10
Benzene		--	< 0.50	< 0.50	< 0.50	< 0.50	< 0.50	< 0.50
Bromodichloromethane		--	< 1.0	< 1.0	< 1.0	< 1.0	< 1.0	< 1.0
Bromoform		--	< 1.0	< 1.0	< 1.0	< 1.0	< 1.0	< 1.0
Bromomethane		--	< 2.0	< 2.0	< 2.0	< 2.0	< 2.0	< 2.0
Carbon Disulfide		--	< 2.0	< 2.0	< 2.0	< 2.0	< 2.0	< 2.0
Carbon Tetrachloride		--	< 1.0	< 1.0	< 1.0	< 1.0	< 1.0	< 1.0
Chlorobenzene		--	< 1.0	< 1.0	< 1.0	< 1.0	< 1.0	< 1.0
Chlorodibromomethane		--	< 1.0	< 1.0	< 1.0	< 1.0	< 1.0	< 1.0
Chloroethane		--	< 1.0	< 1.0	< 1.0	< 1.0	< 1.0	< 1.0
Chloroform		--	< 1.0	< 1.0	< 1.0	< 1.0	< 1.0	< 1.0
Chloromethane		--	< 1.0	< 1.0	< 1.0	< 1.0	< 1.0	< 1.0
cis-1,2-Dichloroethene		--	< 1.0	< 1.0	< 1.0	< 1.0	< 1.0	< 1.0
cis-1,3-Dichloropropene		--	< 1.0	< 1.0	< 1.0	< 1.0	< 1.0	< 1.0
Ethylbenzene		--	< 1.0	< 1.0	< 1.0	< 1.0	< 1.0	< 1.0
Methyl N-Butyl Ketone (2-Hexanone)		--	< 5.0	< 5.0	< 5.0	< 5.0	< 5.0	< 5.0
Methylene Chloride		--	< 2.0	< 2.0	< 2.0	< 2.0	< 2.0	< 2.0
Styrene (Monomer)		--	< 1.0	< 1.0	< 1.0	< 1.0	< 1.0	< 1.0
Tetrachloroethene		--	< 1.0	< 1.0	< 1.0	< 1.0	< 1.0	< 1.0
Toluene		--	< 1.0	< 1.0	< 1.0	< 1.0	< 1.0	< 1.0
trans-1,2-Dichloroethene		--	< 1.0	< 1.0	< 1.0	< 1.0	< 1.0	< 1.0
trans-1,3-Dichloropropene		--	< 1.0	< 1.0	< 1.0	< 1.0	< 1.0	< 1.0
Trichloroethene		--	< 1.0	< 1.0	< 1.0	< 1.0	< 1.0	< 1.0
Vinyl chloride		--	< 1.0	< 1.0	< 1.0	< 1.0	< 1.0	< 1.0
Xylene-o		--	< 1.0	< 1.0	< 1.0	< 1.0	< 1.0	< 1.0
Xylenes- m,p		--	< 1.0	< 1.0	< 1.0	< 1.0	< 1.0	< 1.0
Total VOCs			0	0	0	0	0	0
1,4-Dioxane		< 0.200	--	--	--	--	--	--

See Notes and Abbreviations on last page

Table 19A
Concentrations of Volatile Organic Compounds and
1,4-Dioxane in Blank Samples,
Operable Unit 2, Northrop Grumman Systems Corporation,
Bethpage, New York

Constituents (units in g/L)	Analytical Method Sample ID: Sample Date:	QA/QC	QA/QC	QA/QC	QA/QC	QA/QC	QA/QC	QA/QC
		USEPA Method 8260 TB050317AD1 5/3/2017	USEPA Method 8260 TB050417AD1 5/4/2017	USEPA Method 522 FB050417AD1 5/4/2017	USEPA Method 8260 FB050417AD1 5/4/2017	USEPA Method 8260 TB050517AD1 5/5/2017	USEPA Method 522 FB050517AD1 5/5/2017	USEPA Method 8260 FB050517AD1 5/5/2017
1,1,1-Trichloroethane		< 1.0	< 1.0	--	< 1.0	< 1.0	--	< 1.0
1,1,2,2-Tetrachloroethane		< 1.0	< 1.0	--	< 1.0	< 1.0	--	< 1.0
1,1,2-trichloro-1,2,2-trifluoroethane		< 5.0	< 5.0	--	< 5.0	< 5.0	--	< 5.0
1,1,2-Trichloroethane		< 1.0	< 1.0	--	< 1.0	< 1.0	--	< 1.0
1,1-Dichloroethane		< 1.0	< 1.0	--	< 1.0	< 1.0	--	< 1.0
1,1-Dichloroethene		< 1.0	< 1.0	--	< 1.0	< 1.0	--	< 1.0
1,2-Dichloroethane		< 1.0	< 1.0	--	< 1.0	< 1.0	--	< 1.0
1,2-Dichloropropane		< 1.0	< 1.0	--	< 1.0	< 1.0	--	< 1.0
2-Butanone (MEK)		< 10	< 10	--	< 10	< 10	--	< 10
4-Methyl-2-Pentanone		< 5.0	< 5.0	--	< 5.0	< 5.0	--	< 5.0
Acetone		< 10	< 10	--	< 10	< 10	--	< 10
Benzene		< 0.50	< 0.50	--	< 0.50	< 0.50	--	< 0.50
Bromodichloromethane		< 1.0	< 1.0	--	< 1.0	< 1.0	--	< 1.0
Bromoform		< 1.0	< 1.0	--	< 1.0	< 1.0	--	< 1.0
Bromomethane		< 2.0	< 2.0	--	< 2.0	< 2.0	--	< 2.0
Carbon Disulfide		< 2.0	< 2.0	--	< 2.0	< 2.0	--	< 2.0
Carbon Tetrachloride		< 1.0	< 1.0	--	< 1.0	< 1.0	--	< 1.0
Chlorobenzene		< 1.0	< 1.0	--	< 1.0	< 1.0	--	< 1.0
Chlorodibromomethane		< 1.0	< 1.0	--	< 1.0	< 1.0	--	< 1.0
Chloroethane		< 1.0	< 1.0	--	< 1.0	< 1.0	--	< 1.0
Chloroform		< 1.0	< 1.0	--	< 1.0	< 1.0	--	< 1.0
Chloromethane		< 1.0	< 1.0	--	< 1.0	< 1.0	--	< 1.0
cis-1,2-Dichloroethene		< 1.0	< 1.0	--	< 1.0	< 1.0	--	< 1.0
cis-1,3-Dichloropropene		< 1.0	< 1.0	--	< 1.0	< 1.0	--	< 1.0
Ethylbenzene		< 1.0	< 1.0	--	< 1.0	< 1.0	--	< 1.0
Methyl N-Butyl Ketone (2-Hexanone)		< 5.0	< 5.0	--	< 5.0	< 5.0	--	< 5.0
Methylene Chloride		< 2.0	< 2.0	--	< 2.0	< 2.0	--	< 2.0
Styrene (Monomer)		< 1.0	< 1.0	--	< 1.0	< 1.0	--	< 1.0
Tetrachloroethene		< 1.0	< 1.0	--	< 1.0	< 1.0	--	< 1.0
Toluene		< 1.0	< 1.0	--	< 1.0	< 1.0	--	< 1.0
trans-1,2-Dichloroethene		< 1.0	< 1.0	--	< 1.0	< 1.0	--	< 1.0
trans-1,3-Dichloropropene		< 1.0	< 1.0	--	< 1.0	< 1.0	--	< 1.0
Trichloroethene		< 1.0	< 1.0	--	< 1.0	< 1.0	--	< 1.0
Vinyl chloride		< 1.0	< 1.0	--	< 1.0	< 1.0	--	< 1.0
Xylene-o		< 1.0	< 1.0	--	< 1.0	< 1.0	--	< 1.0
Xylenes- m,p		< 1.0	< 1.0	--	< 1.0	< 1.0	--	< 1.0
Total VOCs		0	0		0	0		0
1,4-Dioxane		--	--	< 0.200	--	--	< 0.200	--

See Notes and Abbreviations on last page

Table 19A
Concentrations of Volatile Organic Compounds and
1,4-Dioxane in Blank Samples,
Operable Unit 2, Northrop Grumman Systems Corporation,
Bethpage, New York

Constituents (units in g/L)	Analytical Method Sample ID: Sample Date:	QA/QC	QA/QC	QA/QC	QA/QC	QA/QC	QA/QC	QA/QC
		USEPA Method 524.2	USEPA Method 524.2	USEPA Method 8260	USEPA Method 522	USEPA Method 8260	USEPA Method 524.2	USEPA Method 8260
		TB050917JB1 5/9/2017	TB051017JB1 5/10/2017	TB051917AR1 5/19/2017	FB051917AR1 5/19/2017	FB051917AR1 5/19/2017	TB052617AD1 5/26/2017	TB061217AD1 6/12/2017
1,1,1-Trichloroethane		< 0.50	< 0.50	< 1.0	--	< 1.0	< 0.50	< 1.0
1,1,2,2-Tetrachloroethane		< 0.50	< 0.50	< 1.0	--	< 1.0	< 0.50	< 1.0
1,1,2-trichloro-1,2,2-trifluoroethane		< 1.0	< 1.0	< 5.0	--	< 5.0	< 1.0	< 5.0
1,1,2-Trichloroethane		< 0.50	< 0.50	< 1.0	--	< 1.0	< 0.50	< 1.0
1,1-Dichloroethane		< 0.50	< 0.50	< 1.0	--	< 1.0	< 0.50	< 1.0
1,1-Dichloroethene		< 0.50	< 0.50	< 1.0	--	< 1.0	< 0.50	< 1.0
1,2-Dichloroethane		< 0.50	< 0.50	< 1.0	--	< 1.0	< 0.50	< 1.0
1,2-Dichloropropane		< 0.50	< 0.50	< 1.0	--	< 1.0	< 0.50	< 1.0
2-Butanone (MEK)		< 5.0	< 5.0	< 10	--	< 10	< 5.0	< 10
4-Methyl-2-Pentanone		< 2.0	< 2.0	< 5.0	--	< 5.0	< 2.0	< 5.0
Acetone		< 5.0	< 5.0	< 10	--	< 10	< 5.0	< 10
Benzene		< 0.50	< 0.50	< 0.50	--	< 0.50	< 0.50	< 0.50
Bromodichloromethane		< 0.50	< 0.50	< 1.0	--	< 1.0	< 0.50	< 1.0
Bromoform		< 0.50	< 0.50	< 1.0	--	< 1.0	< 0.50	< 1.0
Bromomethane		< 0.50	< 0.50	< 2.0	--	< 2.0	< 0.50	< 2.0
Carbon Disulfide		< 0.50	< 0.50	< 2.0	--	< 2.0	< 0.50	< 2.0
Carbon Tetrachloride		< 0.50	< 0.50	< 1.0	--	< 1.0	< 0.50	< 1.0
Chlorobenzene		< 0.50	< 0.50	< 1.0	--	< 1.0	< 0.50	< 1.0
Chlorodibromomethane		< 0.50	< 0.50	< 1.0	--	< 1.0	< 0.50	< 1.0
Chloroethane		< 0.50	< 0.50	< 1.0	--	< 1.0	< 0.50	< 1.0
Chloroform		< 0.50	< 0.50	< 1.0	--	< 1.0	< 0.50	< 1.0
Chloromethane		< 0.50	< 0.50	< 1.0	--	< 1.0	< 0.50	< 1.0
cis-1,2-Dichloroethene		< 0.50	< 0.50	< 1.0	--	< 1.0	< 0.50	< 1.0
cis-1,3-Dichloropropene		< 0.50	< 0.50	< 1.0	--	< 1.0	< 0.50	< 1.0
Ethylbenzene		< 0.50	< 0.50	< 1.0	--	< 1.0	< 0.50	< 1.0
Methyl N-Butyl Ketone (2-Hexanone)		< 2.0	< 2.0	< 5.0	--	< 5.0	< 2.0	< 5.0
Methylene Chloride		< 0.50	< 0.50	< 2.0	--	< 2.0	< 0.50	< 2.0
Styrene (Monomer)		< 0.50	< 0.50	< 1.0	--	< 1.0	< 0.50	< 1.0
Tetrachloroethene		< 0.50	< 0.50	< 1.0	--	< 1.0	< 0.50	< 1.0
Toluene		< 0.50	< 0.50	< 1.0	--	< 1.0	< 0.50	< 1.0
trans-1,2-Dichloroethene		< 0.50	< 0.50	< 1.0	--	< 1.0	< 0.50	< 1.0
trans-1,3-Dichloropropene		< 0.50	< 0.50	< 1.0	--	< 1.0	< 0.50	< 1.0
Trichloroethene		< 0.50	< 0.50	< 1.0	--	< 1.0	< 0.50	< 1.0
Vinyl chloride		< 0.50	< 0.50	< 1.0	--	< 1.0	< 0.50	< 1.0
Xylene-o		< 0.50	< 0.50	< 1.0	--	< 1.0	< 0.50	< 1.0
Xylenes- m,p		< 0.50	< 0.50	< 1.0	--	< 1.0	< 0.50	< 1.0
Total VOCs		0	0	0	0	0	0	0
1,4-Dioxane		--	--	--	< 0.200	--	--	--

See Notes and Abbreviations on last page

Table 19A
Concentrations of Volatile Organic Compounds and
1,4-Dioxane in Blank Samples,
Operable Unit 2, Northrop Grumman Systems Corporation,
Bethpage, New York

Constituents (units in g/L)	Analytical Method Sample ID: Sample Date:	QA/QC	QA/QC	QA/QC	QA/QC	QA/QC	QA/QC	QA/QC
		USEPA Method 524.2 TB061217JB1 6/12/2017	USEPA Method 524.2 TB061317JB1 6/13/2017	USEPA Method 524.2 TB061417AD1 6/14/2017	USEPA Method 8260 TB061517AD1 6/15/2017	USEPA Method 8260 TB061917AD1 6/19/2017	USEPA Method 524.2 TB061917JB1 6/19/2017	USEPA Method 524.2 TB062017JB1 6/20/2017
1,1,1-Trichloroethane		< 0.50	< 0.50	< 0.50	< 1.0	< 1.0	< 0.50	< 0.50
1,1,2,2-Tetrachloroethane		< 0.50	< 0.50	< 0.50	< 1.0	< 1.0	< 0.50	< 0.50
1,1,2-trichloro-1,2,2-trifluoroethane		< 1.0	< 1.0	< 1.0	< 5.0	< 5.0	< 1.0	< 1.0
1,1,2-Trichloroethane		< 0.50	< 0.50	< 0.50	< 1.0	< 1.0	< 0.50	< 0.50
1,1-Dichloroethane		< 0.50	< 0.50	< 0.50	< 1.0	< 1.0	< 0.50	< 0.50
1,1-Dichloroethene		< 0.50	< 0.50	< 0.50	< 1.0	< 1.0	< 0.50	< 0.50
1,2-Dichloroethane		< 0.50	< 0.50	< 0.50	< 1.0	< 1.0	< 0.50	< 0.50
1,2-Dichloropropane		< 0.50	< 0.50	< 0.50	< 1.0	< 1.0	< 0.50	< 0.50
2-Butanone (MEK)		< 5.0	< 5.0	< 5.0	< 10	< 10	< 5.0	< 5.0
4-Methyl-2-Pentanone		< 2.0	< 2.0	< 2.0	< 5.0	< 5.0	< 2.0	< 2.0
Acetone		< 5.0	< 5.0	< 5.0	< 10	< 10	< 5.0	< 5.0
Benzene		< 0.50	< 0.50	< 0.50	< 0.50	< 0.50	< 0.50	< 0.50
Bromodichloromethane		< 0.50	< 0.50	< 0.50	< 1.0	< 1.0	< 0.50	< 0.50
Bromoform		< 0.50	< 0.50	< 0.50	< 1.0	< 1.0	< 0.50	< 0.50
Bromomethane		< 0.50	< 0.50	< 0.50	< 2.0	< 2.0	< 0.50	< 0.50
Carbon Disulfide		< 0.50	< 0.50	< 0.50	< 2.0	< 2.0	< 0.50	< 0.50
Carbon Tetrachloride		< 0.50	< 0.50	< 0.50	< 1.0	< 1.0	< 0.50	< 0.50
Chlorobenzene		< 0.50	< 0.50	< 0.50	< 1.0	< 1.0	< 0.50	< 0.50
Chlorodibromomethane		< 0.50	< 0.50	< 0.50	< 1.0	< 1.0	< 0.50	< 0.50
Chloroethane		< 0.50	< 0.50	< 0.50	< 1.0	< 1.0	< 0.50	< 0.50
Chloroform		< 0.50	< 0.50	< 0.50	< 1.0	< 1.0	< 0.50	< 0.50
Chloromethane		< 0.50	< 0.50	< 0.50	< 1.0	< 1.0	< 0.50	< 0.50
cis-1,2-Dichloroethene		< 0.50	< 0.50	< 0.50	< 1.0	< 1.0	< 0.50	< 0.50
cis-1,3-Dichloropropene		< 0.50	< 0.50	< 0.50	< 1.0	< 1.0	< 0.50	< 0.50
Ethylbenzene		< 0.50	< 0.50	< 0.50	< 1.0	< 1.0	< 0.50	< 0.50
Methyl N-Butyl Ketone (2-Hexanone)		< 2.0	< 2.0	< 2.0	< 5.0	< 5.0	< 2.0	< 2.0
Methylene Chloride		< 0.50	< 0.50	< 0.50	< 2.0	< 2.0	< 0.50	< 0.50
Styrene (Monomer)		< 0.50	< 0.50	< 0.50	< 1.0	< 1.0	< 0.50	< 0.50
Tetrachloroethene		< 0.50	< 0.50	< 0.50	< 1.0	< 1.0	< 0.50	< 0.50
Toluene		< 0.50	< 0.50	< 0.50	< 1.0	< 1.0	< 0.50	< 0.50
trans-1,2-Dichloroethene		< 0.50	< 0.50	< 0.50	< 1.0	< 1.0	< 0.50	< 0.50
trans-1,3-Dichloropropene		< 0.50	< 0.50	< 0.50	< 1.0	< 1.0	< 0.50	< 0.50
Trichloroethene		< 0.50	< 0.50	< 0.50	< 1.0	< 1.0	< 0.50	< 0.50
Vinyl chloride		< 0.50	< 0.50	< 0.50	< 1.0	< 1.0	< 0.50	< 0.50
Xylene-o		< 0.50	< 0.50	< 0.50	< 1.0	< 1.0	< 0.50	< 0.50
Xylenes- m,p		< 0.50	< 0.50	< 0.50	< 1.0	< 1.0	< 0.50	< 0.50
Total VOCs		0	0	0	0	0	0	0
1,4-Dioxane		--	--	--	--	--	--	--

See Notes and Abbreviations on last page

Table 19A
Concentrations of Volatile Organic Compounds and
1,4-Dioxane in Blank Samples,
Operable Unit 2, Northrop Grumman Systems Corporation,
Bethpage, New York

Constituents (units in g/L)	Analytical Method Sample ID: Sample Date:	QA/QC	QA/QC	QA/QC	QA/QC	QA/QC	QA/QC	QA/QC
		USEPA Method 8260 TB062117AD1 6/21/2017	USEPA Method 8260 TB062117JB1 6/21/2017	USEPA Method 522 FB062117AD1 6/21/2017	USEPA Method 8260 FB062117AD1 6/21/2017	USEPA Method 522 FB062117JB1 6/21/2017	USEPA Method 8260 FB062117JB1 6/21/2017	USEPA Method 8260 TB062217AD1 6/22/2017
1,1,1-Trichloroethane		< 1.0	< 1.0	--	< 1.0	--	< 1.0	< 1.0
1,1,2,2-Tetrachloroethane		< 1.0	< 1.0	--	< 1.0	--	< 1.0	< 1.0
1,1,2-trichloro-1,2,2-trifluoroethane		< 5.0	< 5.0	--	< 5.0	--	< 5.0	< 5.0
1,1,2-Trichloroethane		< 1.0	< 1.0	--	< 1.0	--	< 1.0	< 1.0
1,1-Dichloroethane		< 1.0	< 1.0	--	< 1.0	--	< 1.0	< 1.0
1,1-Dichloroethene		< 1.0	< 1.0	--	< 1.0	--	< 1.0	< 1.0
1,2-Dichloroethane		< 1.0	< 1.0	--	< 1.0	--	< 1.0	< 1.0
1,2-Dichloropropane		< 1.0	< 1.0	--	< 1.0	--	< 1.0	< 1.0
2-Butanone (MEK)		< 10	< 10	--	< 10	--	< 10	< 10
4-Methyl-2-Pentanone		< 5.0	< 5.0	--	< 5.0	--	< 5.0	< 5.0
Acetone		< 10	< 10	--	< 10	--	< 10	< 10
Benzene		< 0.50	< 0.50	--	< 0.50	--	< 0.50	< 0.50
Bromodichloromethane		< 1.0	< 1.0	--	< 1.0	--	< 1.0	< 1.0
Bromoform		< 1.0	< 1.0	--	< 1.0	--	< 1.0	< 1.0
Bromomethane		< 2.0	< 2.0	--	< 2.0	--	< 2.0	< 2.0
Carbon Disulfide		< 2.0	< 2.0	--	< 2.0	--	< 2.0	< 2.0
Carbon Tetrachloride		< 1.0	< 1.0	--	< 1.0	--	< 1.0	< 1.0
Chlorobenzene		< 1.0	< 1.0	--	< 1.0	--	< 1.0	< 1.0
Chlorodibromomethane		< 1.0	< 1.0	--	< 1.0	--	< 1.0	< 1.0
Chloroethane		< 1.0	< 1.0	--	< 1.0	--	< 1.0	< 1.0
Chloroform		< 1.0	< 1.0	--	< 1.0	--	< 1.0	< 1.0
Chloromethane		< 1.0	< 1.0	--	< 1.0	--	< 1.0	< 1.0
cis-1,2-Dichloroethene		< 1.0	< 1.0	--	< 1.0	--	< 1.0	< 1.0
cis-1,3-Dichloropropene		< 1.0	< 1.0	--	< 1.0	--	< 1.0	< 1.0
Ethylbenzene		< 1.0	< 1.0	--	< 1.0	--	< 1.0	< 1.0
Methyl N-Butyl Ketone (2-Hexanone)		< 5.0	< 5.0	--	< 5.0	--	< 5.0	< 5.0
Methylene Chloride		< 2.0	< 2.0	--	< 2.0	--	< 2.0	< 2.0
Styrene (Monomer)		< 1.0	< 1.0	--	< 1.0	--	< 1.0	< 1.0
Tetrachloroethene		< 1.0	< 1.0	--	< 1.0	--	< 1.0	< 1.0
Toluene		< 1.0	< 1.0	--	< 1.0	--	< 1.0	< 1.0
trans-1,2-Dichloroethene		< 1.0	< 1.0	--	< 1.0	--	< 1.0	< 1.0
trans-1,3-Dichloropropene		< 1.0	< 1.0	--	< 1.0	--	< 1.0	< 1.0
Trichloroethene		< 1.0	< 1.0	--	< 1.0	--	< 1.0	< 1.0
Vinyl chloride		< 1.0	< 1.0	--	< 1.0	--	< 1.0	< 1.0
Xylene-o		< 1.0	< 1.0	--	< 1.0	--	< 1.0	< 1.0
Xylenes- m,p		< 1.0	< 1.0	--	< 1.0	--	< 1.0	< 1.0
Total VOCs		0	0	0	0	0	0	0
1,4-Dioxane		--	--	< 0.200	--	< 0.200	--	--

See Notes and Abbreviations on last page

Table 19A
Concentrations of Volatile Organic Compounds and
1,4-Dioxane in Blank Samples,
Operable Unit 2, Northrop Grumman Systems Corporation,
Bethpage, New York

Constituents (units in g/L)	Analytical Method Sample ID: Sample Date:	QA/QC	QA/QC	QA/QC	QA/QC	QA/QC	QA/QC	QA/QC
		USEPA Method 522 FB062217AD1 6/22/2017	USEPA Method 8260 FB062217AD1 6/22/2017	USEPA Method 8260 TB062317JB1 6/23/2017	USEPA Method 522 FB062317AR1 6/23/2017	USEPA Method 8260 FB062317AR1 6/23/2017	USEPA Method 8260 TB062617JB1 6/26/2017	USEPA Method 522 FB062617JB1 6/26/2017
1,1,1-Trichloroethane		--	< 1.0	< 1.0	--	< 1.0	< 1.0	--
1,1,2,2-Tetrachloroethane		--	< 1.0	< 1.0	--	< 1.0	< 1.0	--
1,1,2-trichloro-1,2,2-trifluoroethane		--	< 5.0	< 5.0	--	< 5.0	< 5.0	--
1,1,2-Trichloroethane		--	< 1.0	< 1.0	--	< 1.0	< 1.0	--
1,1-Dichloroethane		--	< 1.0	< 1.0	--	< 1.0	< 1.0	--
1,1-Dichloroethene		--	< 1.0	< 1.0	--	< 1.0	< 1.0	--
1,2-Dichloroethane		--	< 1.0	< 1.0	--	< 1.0	< 1.0	--
1,2-Dichloropropane		--	< 1.0	< 1.0	--	< 1.0	< 1.0	--
2-Butanone (MEK)		--	< 10	< 10	--	< 10	< 10	--
4-Methyl-2-Pentanone		--	< 5.0	< 5.0	--	< 5.0	< 5.0	--
Acetone		--	< 10	< 10	--	< 10	< 10	--
Benzene		--	< 0.50	< 0.50	--	< 0.50	< 0.50	--
Bromodichloromethane		--	< 1.0	< 1.0	--	< 1.0	< 1.0	--
Bromoform		--	< 1.0	< 1.0	--	< 1.0	< 1.0	--
Bromomethane		--	< 2.0	< 2.0	--	< 2.0	< 2.0	--
Carbon Disulfide		--	< 2.0	< 2.0	--	< 2.0	< 2.0	--
Carbon Tetrachloride		--	< 1.0	< 1.0	--	< 1.0	< 1.0	--
Chlorobenzene		--	< 1.0	< 1.0	--	< 1.0	< 1.0	--
Chlorodibromomethane		--	< 1.0	< 1.0	--	< 1.0	< 1.0	--
Chloroethane		--	< 1.0	< 1.0	--	< 1.0	< 1.0	--
Chloroform		--	< 1.0	< 1.0	--	< 1.0	< 1.0	--
Chloromethane		--	< 1.0	< 1.0	--	< 1.0	< 1.0	--
cis-1,2-Dichloroethene		--	< 1.0	< 1.0	--	< 1.0	< 1.0	--
cis-1,3-Dichloropropene		--	< 1.0	< 1.0	--	< 1.0	< 1.0	--
Ethylbenzene		--	< 1.0	< 1.0	--	< 1.0	< 1.0	--
Methyl N-Butyl Ketone (2-Hexanone)		--	< 5.0	< 5.0	--	< 5.0	< 5.0	--
Methylene Chloride		--	< 2.0	< 2.0	--	< 2.0	< 2.0	--
Styrene (Monomer)		--	< 1.0	< 1.0	--	< 1.0	< 1.0	--
Tetrachloroethene		--	< 1.0	< 1.0	--	< 1.0	< 1.0	--
Toluene		--	< 1.0	< 1.0	--	< 1.0	< 1.0	--
trans-1,2-Dichloroethene		--	< 1.0	< 1.0	--	< 1.0	< 1.0	--
trans-1,3-Dichloropropene		--	< 1.0	< 1.0	--	< 1.0	< 1.0	--
Trichloroethene		--	< 1.0	< 1.0	--	< 1.0	< 1.0	--
Vinyl chloride		--	< 1.0	< 1.0	--	< 1.0	< 1.0	--
Xylene-o		--	< 1.0	< 1.0	--	< 1.0	< 1.0	--
Xylenes- m,p		--	< 1.0	< 1.0	--	< 1.0	< 1.0	--
Total VOCs			0	0		0	0	
1,4-Dioxane		< 0.200	--	--	< 0.200	--	--	< 0.200

See Notes and Abbreviations on last page

Table 19A
Concentrations of Volatile Organic Compounds and
1,4-Dioxane in Blank Samples,
Operable Unit 2, Northrop Grumman Systems Corporation,
Bethpage, New York

Constituents (units in g/L)	Analytical Method Sample ID: Sample Date:	QA/QC	QA/QC	QA/QC	QA/QC	QA/QC	QA/QC	QA/QC
		USEPA Method 8260	USEPA Method 524.2	USEPA Method 522	USEPA Method 8260	USEPA Method 8260	USEPA Method 522	USEPA Method 8260
		FB062617JB1 6/26/2017	TB062717AD1 6/27/2017	FB062717PP1 6/27/2017	TB-062817AD1 6/28/2017	TB062817PP1 6/28/2017	FB062817PP1 6/28/2017	FB062817PP1 6/28/2017
1,1,1-Trichloroethane		< 1.0	< 0.50	--	< 1.0	< 1.0	--	< 1.0
1,1,2,2-Tetrachloroethane		< 1.0	< 0.50	--	< 1.0	< 1.0	--	< 1.0
1,1,2-trichloro-1,2,2-trifluoroethane		< 5.0	< 1.0	--	< 5.0	< 5.0	--	< 5.0
1,1,2-Trichloroethane		< 1.0	< 0.50	--	< 1.0	< 1.0	--	< 1.0
1,1-Dichloroethane		< 1.0	< 0.50	--	< 1.0	< 1.0	--	< 1.0
1,1-Dichloroethene		< 1.0	< 0.50	--	< 1.0	< 1.0	--	< 1.0
1,2-Dichloroethane		< 1.0	< 0.50	--	< 1.0	< 1.0	--	< 1.0
1,2-Dichloropropane		< 1.0	< 0.50	--	< 1.0	< 1.0	--	< 1.0
2-Butanone (MEK)		< 10	< 5.0	--	< 10	< 10	--	< 10
4-Methyl-2-Pentanone		< 5.0	< 2.0	--	< 5.0	< 5.0	--	< 5.0
Acetone		< 10	< 5.0	--	< 10	< 10	--	< 10
Benzene		< 0.50	< 0.50	--	< 0.50	< 0.50	--	< 0.50
Bromodichloromethane		< 1.0	< 0.50	--	< 1.0	< 1.0	--	< 1.0
Bromoform		< 1.0	< 0.50	--	< 1.0	< 1.0	--	< 1.0
Bromomethane		< 2.0	< 0.50	--	< 2.0	< 2.0	--	< 2.0
Carbon Disulfide		< 2.0	< 0.50	--	< 2.0	< 2.0	--	< 2.0
Carbon Tetrachloride		< 1.0	< 0.50	--	< 1.0	< 1.0	--	< 1.0
Chlorobenzene		< 1.0	< 0.50	--	< 1.0	< 1.0	--	< 1.0
Chlorodibromomethane		< 1.0	< 0.50	--	< 1.0	< 1.0	--	< 1.0
Chloroethane		< 1.0	< 0.50	--	< 1.0	< 1.0	--	< 1.0
Chloroform		< 1.0	< 0.50	--	< 1.0	< 1.0	--	< 1.0
Chloromethane		< 1.0	< 0.50	--	< 1.0	< 1.0	--	< 1.0
cis-1,2-Dichloroethene		< 1.0	< 0.50	--	< 1.0	< 1.0	--	< 1.0
cis-1,3-Dichloropropene		< 1.0	< 0.50	--	< 1.0	< 1.0	--	< 1.0
Ethylbenzene		< 1.0	< 0.50	--	< 1.0	< 1.0	--	< 1.0
Methyl N-Butyl Ketone (2-Hexanone)		< 5.0	< 2.0	--	< 5.0	< 5.0	--	< 5.0
Methylene Chloride		< 2.0	< 0.50	--	< 2.0	< 2.0	--	< 2.0
Styrene (Monomer)		< 1.0	< 0.50	--	< 1.0	< 1.0	--	< 1.0
Tetrachloroethene		< 1.0	< 0.50	--	< 1.0	< 1.0	--	< 1.0
Toluene		< 1.0	< 0.50	--	< 1.0	< 1.0	--	< 1.0
trans-1,2-Dichloroethene		< 1.0	< 0.50	--	< 1.0	< 1.0	--	< 1.0
trans-1,3-Dichloropropene		< 1.0	< 0.50	--	< 1.0	< 1.0	--	< 1.0
Trichloroethene		< 1.0	< 0.50	--	< 1.0	< 1.0	--	< 1.0
Vinyl chloride		< 1.0	< 0.50	--	< 1.0	< 1.0	--	< 1.0
Xylene-o		< 1.0	< 0.50	--	< 1.0	< 1.0	--	< 1.0
Xylenes- m,p		< 1.0	< 0.50	--	< 1.0	< 1.0	--	< 1.0
Total VOCs		0	0	0	0	0	0	0
1,4-Dioxane		--	--	< 0.200	--	--	< 0.200	--

See Notes and Abbreviations on last page

Table 19A
Concentrations of Volatile Organic Compounds and
1,4-Dioxane in Blank Samples,
Operable Unit 2, Northrop Grumman Systems Corporation,
Bethpage, New York

Constituents (units in g/L)	Analytical Method Sample ID: Sample Date:	QA/QC	QA/QC	QA/QC	QA/QC	QA/QC	QA/QC	QA/QC
		USEPA Method 8260 TB062917AR1 6/29/2017	USEPA Method 522 FB062917AD1 6/29/2017	USEPA Method 8260 FB062917AD1 6/29/2017	USEPA Method 522 FB062917PP1 6/29/2017	USEPA Method 8260 TB070517PP1 7/5/2017	USEPA Method 522 FB070517PP1 7/5/2017	USEPA Method 8260 FB070517PP1 7/5/2017
1,1,1-Trichloroethane		< 1.0	--	< 1.0	--	< 1.0	--	< 1.0
1,1,2,2-Tetrachloroethane		< 1.0	--	< 1.0	--	< 1.0	--	< 1.0
1,1,2-trichloro-1,2,2-trifluoroethane		< 5.0	--	< 5.0	--	< 5.0	--	< 5.0
1,1,2-Trichloroethane		< 1.0	--	< 1.0	--	< 1.0	--	< 1.0
1,1-Dichloroethane		< 1.0	--	< 1.0	--	< 1.0	--	< 1.0
1,1-Dichloroethene		< 1.0	--	< 1.0	--	< 1.0	--	< 1.0
1,2-Dichloroethane		< 1.0	--	< 1.0	--	< 1.0	--	< 1.0
1,2-Dichloropropane		< 1.0	--	< 1.0	--	< 1.0	--	< 1.0
2-Butanone (MEK)		< 10	--	< 10	--	< 10	--	< 10
4-Methyl-2-Pentanone		< 5.0	--	< 5.0	--	< 5.0	--	< 5.0
Acetone		< 10	--	< 10	--	< 10	--	< 10
Benzene		< 0.50	--	< 0.50	--	< 0.50	--	< 0.50
Bromodichloromethane		< 1.0	--	< 1.0	--	< 1.0	--	< 1.0
Bromoform		< 1.0	--	< 1.0	--	< 1.0	--	< 1.0
Bromomethane		< 2.0	--	< 2.0	--	< 2.0	--	< 2.0
Carbon Disulfide		< 2.0	--	< 2.0	--	< 2.0	--	< 2.0
Carbon Tetrachloride		< 1.0	--	< 1.0	--	< 1.0	--	< 1.0
Chlorobenzene		< 1.0	--	< 1.0	--	< 1.0	--	< 1.0
Chlorodibromomethane		< 1.0	--	< 1.0	--	< 1.0	--	< 1.0
Chloroethane		< 1.0	--	< 1.0	--	< 1.0	--	< 1.0
Chloroform		< 1.0	--	< 1.0	--	< 1.0	--	< 1.0
Chloromethane		< 1.0	--	< 1.0	--	< 1.0	--	< 1.0
cis-1,2-Dichloroethene		< 1.0	--	< 1.0	--	< 1.0	--	< 1.0
cis-1,3-Dichloropropene		< 1.0	--	< 1.0	--	< 1.0	--	< 1.0
Ethylbenzene		< 1.0	--	< 1.0	--	< 1.0	--	< 1.0
Methyl N-Butyl Ketone (2-Hexanone)		< 5.0	--	< 5.0	--	< 5.0	--	< 5.0
Methylene Chloride		< 2.0	--	< 2.0	--	< 2.0	--	< 2.0
Styrene (Monomer)		< 1.0	--	< 1.0	--	< 1.0	--	< 1.0
Tetrachloroethene		< 1.0	--	< 1.0	--	< 1.0	--	< 1.0
Toluene		< 1.0	--	< 1.0	--	< 1.0	--	< 1.0
trans-1,2-Dichloroethene		< 1.0	--	< 1.0	--	< 1.0	--	< 1.0
trans-1,3-Dichloropropene		< 1.0	--	< 1.0	--	< 1.0	--	< 1.0
Trichloroethene		< 1.0	--	< 1.0	--	< 1.0	--	< 1.0
Vinyl chloride		< 1.0	--	< 1.0	--	< 1.0	--	< 1.0
Xylene-o		< 1.0	--	< 1.0	--	< 1.0	--	< 1.0
Xylenes- m,p		< 1.0	--	< 1.0	--	< 1.0	--	< 1.0
Total VOCs		0	0	0	0	0	0	0
1,4-Dioxane		--	< 0.200	--	< 0.200	--	< 0.200	--

See Notes and Abbreviations on last page

Table 19A
Concentrations of Volatile Organic Compounds and
1,4-Dioxane in Blank Samples,
Operable Unit 2, Northrop Grumman Systems Corporation,
Bethpage, New York

Constituents (units in g/L)	Analytical Method Sample ID: Sample Date:	QA/QC	QA/QC	QA/QC	QA/QC	QA/QC	QA/QC	QA/QC
		USEPA Method 524.2 TB070617PP1 7/6/2017	USEPA Method 8260 TB070717PP2 7/7/2017	USEPA Method 522 FB070717PP2 7/7/2017	USEPA Method 8260 FB070717PP2 7/7/2017	USEPA Method 8260 TB071017AD1 7/10/2017	USEPA Method 522 FB071017AD1 7/10/2017	USEPA Method 8260 FB071017AD1 7/10/2017
1,1,1-Trichloroethane		< 0.50	< 1.0	--	< 1.0	< 1.0	--	< 1.0
1,1,2,2-Tetrachloroethane		< 0.50	< 1.0	--	< 1.0	< 1.0	--	< 1.0
1,1,2-trichloro-1,2,2-trifluoroethane		< 1.0	< 5.0	--	< 5.0	< 5.0	--	< 5.0
1,1,2-Trichloroethane		< 0.50	< 1.0	--	< 1.0	< 1.0	--	< 1.0
1,1-Dichloroethane		< 0.50	< 1.0	--	< 1.0	< 1.0	--	< 1.0
1,1-Dichloroethene		< 0.50	< 1.0	--	< 1.0	< 1.0	--	< 1.0
1,2-Dichloroethane		< 0.50	< 1.0	--	< 1.0	< 1.0	--	< 1.0
1,2-Dichloropropane		< 0.50	< 1.0	--	< 1.0	< 1.0	--	< 1.0
2-Butanone (MEK)		< 5.0	< 10	--	< 10	< 10	--	< 10
4-Methyl-2-Pentanone		< 2.0	< 5.0	--	< 5.0	< 5.0	--	< 5.0
Acetone		< 5.0	< 10	--	< 10	< 10	--	< 10
Benzene		< 0.50	< 0.50	--	< 0.50	< 0.50	--	< 0.50
Bromodichloromethane		< 0.50	< 1.0	--	< 1.0	< 1.0	--	< 1.0
Bromoform		< 0.50	< 1.0	--	< 1.0	< 1.0	--	< 1.0
Bromomethane		< 0.50	< 2.0	--	< 2.0	< 2.0	--	< 2.0
Carbon Disulfide		< 0.50	< 2.0	--	< 2.0	< 2.0	--	< 2.0
Carbon Tetrachloride		< 0.50	< 1.0	--	< 1.0	< 1.0	--	< 1.0
Chlorobenzene		< 0.50	< 1.0	--	< 1.0	< 1.0	--	< 1.0
Chlorodibromomethane		< 0.50	< 1.0	--	< 1.0	< 1.0	--	< 1.0
Chloroethane		< 0.50	< 1.0	--	< 1.0	< 1.0	--	< 1.0
Chloroform		< 0.50	< 1.0	--	< 1.0	< 1.0	--	< 1.0
Chloromethane		< 0.50	< 1.0	--	< 1.0	< 1.0	--	< 1.0
cis-1,2-Dichloroethene		< 0.50	< 1.0	--	< 1.0	< 1.0	--	< 1.0
cis-1,3-Dichloropropene		< 0.50	< 1.0	--	< 1.0	< 1.0	--	< 1.0
Ethylbenzene		< 0.50	< 1.0	--	< 1.0	< 1.0	--	< 1.0
Methyl N-Butyl Ketone (2-Hexanone)		< 2.0	< 5.0	--	< 5.0	< 5.0	--	< 5.0
Methylene Chloride		< 0.50	< 2.0	--	< 2.0	< 2.0	--	< 2.0
Styrene (Monomer)		< 0.50	< 1.0	--	< 1.0	< 1.0	--	< 1.0
Tetrachloroethene		< 0.50	< 1.0	--	< 1.0	< 1.0	--	< 1.0
Toluene		< 0.50	< 1.0	--	< 1.0	< 1.0	--	< 1.0
trans-1,2-Dichloroethene		< 0.50	< 1.0	--	< 1.0	< 1.0	--	< 1.0
trans-1,3-Dichloropropene		< 0.50	< 1.0	--	< 1.0	< 1.0	--	< 1.0
Trichloroethene		< 0.50	< 1.0	--	< 1.0	< 1.0	--	< 1.0
Vinyl chloride		< 0.50	< 1.0	--	< 1.0	< 1.0	--	< 1.0
Xylene-o		< 0.50	< 1.0	--	< 1.0	< 1.0	--	< 1.0
Xylenes- m,p		< 0.50	< 1.0	--	< 1.0	< 1.0	--	< 1.0
Total VOCs		0	0		0	0		0
1,4-Dioxane		--	--	< 0.200	--	--	< 0.200	--

See Notes and Abbreviations on last page

Table 19A
Concentrations of Volatile Organic Compounds and
1,4-Dioxane in Blank Samples,
Operable Unit 2, Northrop Grumman Systems Corporation,
Bethpage, New York

Constituents (units in g/L)	Analytical Method Sample ID: Sample Date:	QA/QC	QA/QC	QA/QC	QA/QC	QA/QC	QA/QC	QA/QC
		USEPA Method 8260 TB071117AD1 7/11/2017	USEPA Method 522 FB071117AD1 7/11/2017	USEPA Method 8260 FB071117AD1 7/11/2017	USEPA Method 524.2 TB091217AP1 9/12/2017	USEPA Method 8260 TB101917DC1 10/19/2017	USEPA Method 522 FB102017DC1 10/20/2017	USEPA Method 524.2 TB102317AR1 10/23/2017
1,1,1-Trichloroethane		< 1.0	--	< 1.0	< 0.50	< 1.0	--	< 0.50
1,1,2,2-Tetrachloroethane		< 1.0	--	< 1.0	< 0.50	< 1.0	--	< 0.50
1,1,2-trichloro-1,2,2-trifluoroethane		< 5.0	--	< 5.0	< 1.0	< 5.0	--	< 1.0
1,1,2-Trichloroethane		< 1.0	--	< 1.0	< 0.50	< 1.0	--	< 0.50
1,1-Dichloroethane		< 1.0	--	< 1.0	< 0.50	< 1.0	--	< 0.50
1,1-Dichloroethene		< 1.0	--	< 1.0	< 0.50	< 1.0	--	< 0.50
1,2-Dichloroethane		< 1.0	--	< 1.0	< 0.50	< 1.0	--	< 0.50
1,2-Dichloropropane		< 1.0	--	< 1.0	< 0.50	< 1.0	--	< 0.50
2-Butanone (MEK)		< 10	--	< 10	< 5.0	< 10	--	< 5.0
4-Methyl-2-Pentanone		< 5.0	--	< 5.0	< 2.0	< 5.0	--	< 2.0
Acetone		< 10	--	< 10	< 5.0	< 10	--	< 5.0
Benzene		< 0.50	--	< 0.50	< 0.50	< 0.50	--	< 0.50
Bromodichloromethane		< 1.0	--	< 1.0	< 0.50	< 1.0	--	< 0.50
Bromoform		< 1.0	--	< 1.0	< 0.50	< 1.0	--	< 0.50
Bromomethane		< 2.0	--	< 2.0	< 0.50	< 2.0	--	< 0.50
Carbon Disulfide		< 2.0	--	< 2.0	< 0.50	< 2.0	--	< 0.50
Carbon Tetrachloride		< 1.0	--	< 1.0	< 0.50	< 1.0	--	< 0.50
Chlorobenzene		< 1.0	--	< 1.0	< 0.50	< 1.0	--	< 0.50
Chlorodibromomethane		< 1.0	--	< 1.0	< 0.50	< 1.0	--	< 0.50
Chloroethane		< 1.0	--	< 1.0	< 0.50	< 1.0	--	< 0.50
Chloroform		< 1.0	--	< 1.0	< 0.50	< 1.0	--	< 0.50
Chloromethane		< 1.0	--	< 1.0	< 0.50	< 1.0	--	< 0.50
cis-1,2-Dichloroethene		< 1.0	--	< 1.0	< 0.50	< 1.0	--	< 0.50
cis-1,3-Dichloropropene		< 1.0	--	< 1.0	< 0.50	< 1.0	--	< 0.50
Ethylbenzene		< 1.0	--	< 1.0	< 0.50	< 1.0	--	< 0.50
Methyl N-Butyl Ketone (2-Hexanone)		< 5.0	--	< 5.0	< 2.0	< 5.0	--	< 2.0
Methylene Chloride		< 2.0	--	< 2.0	< 0.50	< 2.0	--	< 0.50
Styrene (Monomer)		< 1.0	--	< 1.0	< 0.50	< 1.0	--	< 0.50
Tetrachloroethene		< 1.0	--	< 1.0	< 0.50	< 1.0	--	< 0.50
Toluene		< 1.0	--	< 1.0	< 0.50	< 1.0	--	< 0.50
trans-1,2-Dichloroethene		< 1.0	--	< 1.0	< 0.50	< 1.0	--	< 0.50
trans-1,3-Dichloropropene		< 1.0	--	< 1.0	< 0.50	< 1.0	--	< 0.50
Trichloroethene		< 1.0	--	< 1.0	< 0.50	< 1.0	--	< 0.50
Vinyl chloride		< 1.0	--	< 1.0	< 0.50	< 1.0	--	< 0.50
Xylene-o		< 1.0	--	< 1.0	< 0.50	< 1.0	--	< 0.50
Xylenes- m,p		< 1.0	--	< 1.0	< 0.50	< 1.0	--	< 0.50
Total VOCs		0	0	0	0	0		0
1,4-Dioxane		--	< 0.200	--	--	--	< 0.200	--

See Notes and Abbreviations on last page

Table 19A
Concentrations of Volatile Organic Compounds and
1,4-Dioxane in Blank Samples,
Operable Unit 2, Northrop Grumman Systems Corporation,
Bethpage, New York

Constituents (units in g/L)	Analytical Method Sample ID: Sample Date:	QA/QC	QA/QC	QA/QC	QA/QC	QA/QC	QA/QC	QA/QC
		USEPA Method 8260 TB102417DC1 10/24/2017	USEPA Method 8260 TB102517PP1 10/25/2017	USEPA Method 8260 FB102517PP1 10/25/2017	USEPA Method 522 FB102517PP1_20171025 10/25/2017	USEPA Method 8260 TB102717PP1 10/27/2017	USEPA Method 8260 FB102717AR1 10/27/2017	USEPA Method 522 FB102717AR1_20171027 10/27/2017
1,1,1-Trichloroethane		< 1.0	< 1.0	< 1.0	--	< 1.0	< 1.0	--
1,1,2,2-Tetrachloroethane		< 1.0	< 1.0	< 1.0	--	< 1.0	< 1.0	--
1,1,2-trichloro-1,2,2-trifluoroethane		< 5.0	< 5.0	< 5.0	--	< 5.0	< 5.0	--
1,1,2-Trichloroethane		< 1.0	< 1.0	< 1.0	--	< 1.0	< 1.0	--
1,1-Dichloroethane		< 1.0	< 1.0	< 1.0	--	< 1.0	< 1.0	--
1,1-Dichloroethene		< 1.0	< 1.0	< 1.0	--	< 1.0	< 1.0	--
1,2-Dichloroethane		< 1.0	< 1.0	< 1.0	--	< 1.0	< 1.0	--
1,2-Dichloropropane		< 1.0	< 1.0	< 1.0	--	< 1.0	< 1.0	--
2-Butanone (MEK)		< 10	< 10	< 10	--	< 10	< 10	--
4-Methyl-2-Pentanone		< 5.0	< 5.0	< 5.0	--	< 5.0	< 5.0	--
Acetone		< 10	< 10	< 10	--	< 10	< 10	--
Benzene		< 0.50	< 0.50	< 0.50	--	< 0.50	< 0.50	--
Bromodichloromethane		< 1.0	< 1.0	< 1.0	--	< 1.0	< 1.0	--
Bromoform		< 1.0	< 1.0	< 1.0	--	< 1.0	< 1.0	--
Bromomethane		< 2.0	< 2.0	< 2.0	--	< 2.0	< 2.0	--
Carbon Disulfide		< 2.0	< 2.0	< 2.0	--	< 2.0	< 2.0	--
Carbon Tetrachloride		< 1.0	< 1.0	< 1.0	--	< 1.0	< 1.0	--
Chlorobenzene		< 1.0	< 1.0	< 1.0	--	< 1.0	< 1.0	--
Chlorodibromomethane		< 1.0	< 1.0	< 1.0	--	< 1.0	< 1.0	--
Chloroethane		< 1.0	< 1.0	< 1.0	--	< 1.0	< 1.0	--
Chloroform		< 1.0	< 1.0	< 1.0	--	< 1.0	< 1.0	--
Chloromethane		< 1.0	< 1.0	< 1.0	--	< 1.0	< 1.0	--
cis-1,2-Dichloroethene		< 1.0	< 1.0	< 1.0	--	< 1.0	< 1.0	--
cis-1,3-Dichloropropene		< 1.0	< 1.0	< 1.0	--	< 1.0	< 1.0	--
Ethylbenzene		< 1.0	< 1.0	< 1.0	--	< 1.0	< 1.0	--
Methyl N-Butyl Ketone (2-Hexanone)		< 5.0	< 5.0	< 5.0	--	< 5.0	< 5.0	--
Methylene Chloride		< 2.0	< 2.0	< 2.0	--	< 2.0	< 2.0	--
Styrene (Monomer)		< 1.0	< 1.0	< 1.0	--	< 1.0	< 1.0	--
Tetrachloroethene		< 1.0	< 1.0	< 1.0	--	< 1.0	< 1.0	--
Toluene		< 1.0	< 1.0	< 1.0	--	< 1.0	< 1.0	--
trans-1,2-Dichloroethene		< 1.0	< 1.0	< 1.0	--	< 1.0	< 1.0	--
trans-1,3-Dichloropropene		< 1.0	< 1.0	< 1.0	--	< 1.0	< 1.0	--
Trichloroethene		< 1.0	< 1.0	< 1.0	--	< 1.0	< 1.0	--
Vinyl chloride		< 1.0	< 1.0	< 1.0	--	< 1.0	< 1.0	--
Xylene-o		< 1.0	< 1.0	< 1.0	--	< 1.0	< 1.0	--
Xylenes- m,p		< 1.0	< 1.0	< 1.0	--	< 1.0	< 1.0	--
Total VOCs		0	0	0		0	0	
1,4-Dioxane		--	--	--	< 0.200	--	--	< 0.200

See Notes and Abbreviations on last page

Table 19A
Concentrations of Volatile Organic Compounds and
1,4-Dioxane in Blank Samples,
Operable Unit 2, Northrop Grumman Systems Corporation,
Bethpage, New York

Constituents (units in g/L)	Analytical Method Sample ID: Sample Date:	QA/QC	QA/QC	QA/QC	QA/QC	QA/QC	QA/QC	QA/QC
		USEPA Method 8260 TB103017AR1 10/30/2017	USEPA Method 8260 TB103017PP1 10/30/2017	USEPA Method 8260 TB103117DC1 10/31/2017	USEPA Method 8260 TB103117PP1 10/31/2017	USEPA Method 8260 FB103117AR1 10/31/2017	USEPA Method 522 FB103117AR1_20171031 10/31/2017	USEPA Method 8260 TB110117AR1 11/1/2017
1,1,1-Trichloroethane		< 1.0	< 1.0	< 1.0	< 1.0	< 1.0	--	< 1.0
1,1,2,2-Tetrachloroethane		< 1.0	< 1.0	< 1.0	< 1.0	< 1.0	--	< 1.0
1,1,2-trichloro-1,2,2-trifluoroethane		< 5.0	< 5.0	< 5.0	< 5.0	< 5.0	--	< 5.0
1,1,2-Trichloroethane		< 1.0	< 1.0	< 1.0	< 1.0	< 1.0	--	< 1.0
1,1-Dichloroethane		< 1.0	< 1.0	< 1.0	< 1.0	< 1.0	--	< 1.0
1,1-Dichloroethene		< 1.0	< 1.0	< 1.0	< 1.0	< 1.0	--	< 1.0
1,2-Dichloroethane		< 1.0	< 1.0	< 1.0	< 1.0	< 1.0	--	< 1.0
1,2-Dichloropropane		< 1.0	< 1.0	< 1.0	< 1.0	< 1.0	--	< 1.0
2-Butanone (MEK)		< 10	< 10	< 10	< 10	< 10	--	< 10
4-Methyl-2-Pentanone		< 5.0	< 5.0	< 5.0	< 5.0	< 5.0	--	< 5.0
Acetone		< 10	< 10	< 10 J	< 10	< 10 J	--	< 10
Benzene		< 0.50	< 0.50	< 0.50	< 0.50	< 0.50	--	< 0.50
Bromodichloromethane		< 1.0	< 1.0	< 1.0	< 1.0	< 1.0	--	< 1.0
Bromoform		< 1.0	< 1.0	< 1.0	< 1.0	< 1.0	--	< 1.0
Bromomethane		< 2.0	< 2.0	< 2.0	< 2.0	< 2.0	--	< 2.0
Carbon Disulfide		< 2.0	< 2.0	< 2.0	< 2.0	< 2.0	--	< 2.0
Carbon Tetrachloride		< 1.0	< 1.0	< 1.0	< 1.0	< 1.0	--	< 1.0
Chlorobenzene		< 1.0	< 1.0	< 1.0	< 1.0	< 1.0	--	< 1.0
Chlorodibromomethane		< 1.0	< 1.0	< 1.0	< 1.0	< 1.0	--	< 1.0
Chloroethane		< 1.0	< 1.0	< 1.0	< 1.0	< 1.0	--	< 1.0
Chloroform		< 1.0	< 1.0	< 1.0	< 1.0	< 1.0	--	< 1.0
Chloromethane		< 1.0	< 1.0	< 1.0	< 1.0	< 1.0	--	< 1.0
cis-1,2-Dichloroethene		< 1.0	< 1.0	< 1.0	< 1.0	< 1.0	--	< 1.0
cis-1,3-Dichloropropene		< 1.0	< 1.0	< 1.0	< 1.0	< 1.0	--	< 1.0
Ethylbenzene		< 1.0	< 1.0	< 1.0	< 1.0	< 1.0	--	< 1.0
Methyl N-Butyl Ketone (2-Hexanone)		< 5.0	< 5.0	< 5.0	< 5.0	< 5.0	--	< 5.0
Methylene Chloride		< 2.0	< 2.0	< 2.0	< 2.0	< 2.0	--	< 2.0
Styrene (Monomer)		< 1.0	< 1.0	< 1.0	< 1.0	< 1.0	--	< 1.0
Tetrachloroethene		< 1.0	< 1.0	< 1.0	< 1.0	< 1.0	--	< 1.0
Toluene		< 1.0	< 1.0	< 1.0	< 1.0	< 1.0	--	< 1.0
trans-1,2-Dichloroethene		< 1.0	< 1.0	< 1.0	< 1.0	< 1.0	--	< 1.0
trans-1,3-Dichloropropene		< 1.0	< 1.0	< 1.0	< 1.0	< 1.0	--	< 1.0
Trichloroethene		< 1.0	< 1.0	< 1.0	< 1.0	< 1.0	--	< 1.0
Vinyl chloride		< 1.0	< 1.0	< 1.0	< 1.0	< 1.0	--	< 1.0
Xylene-o		< 1.0	< 1.0	< 1.0	< 1.0	< 1.0	--	< 1.0
Xylenes- m,p		< 1.0	< 1.0	< 1.0	< 1.0	< 1.0	--	< 1.0
Total VOCs		0	0	0	0	0		0
1,4-Dioxane		--	--	--	--	--	0.941	--

See Notes and Abbreviations on last page

Table 19A
Concentrations of Volatile Organic Compounds and
1,4-Dioxane in Blank Samples,
Operable Unit 2, Northrop Grumman Systems Corporation,
Bethpage, New York

Constituents (units in g/L)	Analytical Method Sample ID: Sample Date:	QA/QC	QA/QC	QA/QC	QA/QC	QA/QC	QA/QC	QA/QC
		USEPA Method 8260 TB110117PP1 11/1/2017	USEPA Method 522 FB110117DC1 11/1/2017	USEPA Method 8260 FB110117DC1 11/1/2017	USEPA Method 8260 TB110217PP1 11/2/2017	USEPA Method 522 FB110217PP1 11/2/2017	USEPA Method 8260 FB110217PP1 11/2/2017	USEPA Method 524.2 TB110317AR1 11/3/2017
1,1,1-Trichloroethane		< 1.0	--	< 1.0	< 1.0	--	< 1.0	< 0.50
1,1,2,2-Tetrachloroethane		< 1.0	--	< 1.0	< 1.0	--	< 1.0	< 0.50
1,1,2-trichloro-1,2,2-trifluoroethane		< 5.0	--	< 5.0	< 5.0	--	< 5.0	< 1.0
1,1,2-Trichloroethane		< 1.0	--	< 1.0	< 1.0	--	< 1.0	< 0.50
1,1-Dichloroethane		< 1.0	--	< 1.0	< 1.0	--	< 1.0	< 0.50
1,1-Dichloroethene		< 1.0	--	< 1.0	< 1.0	--	< 1.0	< 0.50
1,2-Dichloroethane		< 1.0	--	< 1.0	< 1.0	--	< 1.0	< 0.50
1,2-Dichloropropane		< 1.0	--	< 1.0	< 1.0	--	< 1.0	< 0.50
2-Butanone (MEK)		< 10	--	< 10	< 10	--	< 10	< 5.0
4-Methyl-2-Pentanone		< 5.0	--	< 5.0	< 5.0	--	< 5.0	< 2.0
Acetone		< 10	--	< 10	< 10	--	< 10	< 5.0
Benzene		< 0.50	--	< 0.50	< 0.50	--	< 0.50	< 0.50
Bromodichloromethane		< 1.0	--	< 1.0	< 1.0	--	< 1.0	< 0.50
Bromoform		< 1.0	--	< 1.0	< 1.0	--	< 1.0	< 0.50
Bromomethane		< 2.0	--	< 2.0	< 2.0	--	< 2.0	< 0.50
Carbon Disulfide		< 2.0	--	< 2.0	< 2.0	--	< 2.0	< 0.50
Carbon Tetrachloride		< 1.0	--	< 1.0	< 1.0	--	< 1.0	< 0.50
Chlorobenzene		< 1.0	--	< 1.0	< 1.0	--	< 1.0	< 0.50
Chlorodibromomethane		< 1.0	--	< 1.0	< 1.0	--	< 1.0	< 0.50
Chloroethane		< 1.0	--	< 1.0	< 1.0	--	< 1.0	< 0.50
Chloroform		< 1.0	--	< 1.0	< 1.0	--	< 1.0	< 0.50
Chloromethane		< 1.0	--	< 1.0	< 1.0	--	< 1.0	< 0.50
cis-1,2-Dichloroethene		< 1.0	--	< 1.0	< 1.0	--	< 1.0	< 0.50
cis-1,3-Dichloropropene		< 1.0	--	< 1.0	< 1.0	--	< 1.0	< 0.50
Ethylbenzene		< 1.0	--	< 1.0	< 1.0	--	< 1.0	< 0.50
Methyl N-Butyl Ketone (2-Hexanone)		< 5.0	--	< 5.0	< 5.0	--	< 5.0	< 2.0
Methylene Chloride		< 2.0	--	< 2.0	< 2.0	--	< 2.0	< 0.50
Styrene (Monomer)		< 1.0	--	< 1.0	< 1.0	--	< 1.0	< 0.50
Tetrachloroethene		< 1.0	--	< 1.0	< 1.0	--	< 1.0	< 0.50
Toluene		< 1.0	--	< 1.0	< 1.0	--	< 1.0	< 0.50
trans-1,2-Dichloroethene		< 1.0	--	< 1.0	< 1.0	--	< 1.0	< 0.50
trans-1,3-Dichloropropene		< 1.0	--	< 1.0	< 1.0	--	< 1.0	< 0.50
Trichloroethene		< 1.0	--	< 1.0	< 1.0	--	< 1.0	< 0.50
Vinyl chloride		< 1.0	--	< 1.0	< 1.0	--	< 1.0	< 0.50
Xylene-o		< 1.0	--	< 1.0	< 1.0	--	< 1.0	< 0.50
Xylenes- m,p		< 1.0	--	< 1.0	< 1.0	--	< 1.0	< 0.50
Total VOCs		0	0	0	0		0	0
1,4-Dioxane		--	< 0.200	--	--	< 0.200	--	--

See Notes and Abbreviations on last page

Table 19A
Concentrations of Volatile Organic Compounds and
1,4-Dioxane in Blank Samples,
Operable Unit 2, Northrop Grumman Systems Corporation,
Bethpage, New York

Constituents (units in g/L)	Analytical Method Sample ID: Sample Date:	QA/QC	QA/QC	QA/QC	QA/QC	QA/QC	QA/QC	QA/QC
		USEPA Method 8260 TB110317PP1 11/3/2017	USEPA Method 522 FB110317PP1 11/3/2017	USEPA Method 8260 FB110317PP1 11/3/2017	USEPA Method 524.2 TB110617AR1 11/6/2017	USEPA Method 524.2 TB110717AD1 11/7/2017	USEPA Method 524.2 TB110817AR1 11/8/2017	USEPA Method 524.2 TB111017AD1 11/10/2017
1,1,1-Trichloroethane		< 1.0	--	< 1.0	< 0.50	< 0.50	< 0.50	< 0.50
1,1,2,2-Tetrachloroethane		< 1.0	--	< 1.0	< 0.50	< 0.50	< 0.50	< 0.50
1,1,2-trichloro-1,2,2-trifluoroethane		< 5.0	--	< 5.0	< 1.0	< 1.0	< 1.0	< 1.0
1,1,2-Trichloroethane		< 1.0	--	< 1.0	< 0.50	< 0.50	< 0.50	< 0.50
1,1-Dichloroethane		< 1.0	--	< 1.0	< 0.50	< 0.50	< 0.50	< 0.50
1,1-Dichloroethene		< 1.0	--	< 1.0	< 0.50	< 0.50	< 0.50	< 0.50
1,2-Dichloroethane		< 1.0	--	< 1.0	< 0.50	< 0.50	< 0.50	< 0.50
1,2-Dichloropropane		< 1.0	--	< 1.0	< 0.50	< 0.50	< 0.50	< 0.50
2-Butanone (MEK)		< 10	--	< 10	< 5.0	< 5.0	< 5.0	< 5.0
4-Methyl-2-Pentanone		< 5.0	--	< 5.0	< 2.0	< 2.0	< 2.0	< 2.0
Acetone		< 10	--	< 10	< 5.0	< 5.0	< 5.0	< 5.0
Benzene		< 0.50	--	< 0.50	< 0.50	< 0.50	< 0.50	< 0.50
Bromodichloromethane		< 1.0	--	< 1.0	< 0.50	< 0.50	< 0.50	< 0.50
Bromoform		< 1.0	--	< 1.0	< 0.50	< 0.50	< 0.50	< 0.50
Bromomethane		< 2.0	--	< 2.0	< 0.50	< 0.50	< 0.50	< 0.50
Carbon Disulfide		< 2.0	--	< 2.0	< 0.50	< 0.50	< 0.50	< 0.50
Carbon Tetrachloride		< 1.0	--	< 1.0	< 0.50	< 0.50	< 0.50	< 0.50
Chlorobenzene		< 1.0	--	< 1.0	< 0.50	< 0.50	< 0.50	< 0.50
Chlorodibromomethane		< 1.0	--	< 1.0	< 0.50	< 0.50	< 0.50	< 0.50
Chloroethane		< 1.0	--	< 1.0	< 0.50	< 0.50	< 0.50	< 0.50
Chloroform		< 1.0	--	< 1.0	< 0.50	< 0.50	< 0.50	< 0.50
Chloromethane		< 1.0	--	< 1.0	< 0.50	< 0.50	< 0.50	< 0.50
cis-1,2-Dichloroethene		< 1.0	--	< 1.0	< 0.50	< 0.50	< 0.50	< 0.50
cis-1,3-Dichloropropene		< 1.0	--	< 1.0	< 0.50	< 0.50	< 0.50	< 0.50
Ethylbenzene		< 1.0	--	< 1.0	< 0.50	< 0.50	< 0.50	< 0.50
Methyl N-Butyl Ketone (2-Hexanone)		< 5.0	--	< 5.0	< 2.0	< 2.0	< 2.0	< 2.0
Methylene Chloride		< 2.0	--	< 2.0	< 0.50	< 0.50	< 0.50	< 0.50
Styrene (Monomer)		< 1.0	--	< 1.0	< 0.50	< 0.50	< 0.50	< 0.50
Tetrachloroethene		< 1.0	--	< 1.0	< 0.50	< 0.50	< 0.50	< 0.50
Toluene		< 1.0	--	< 1.0	< 0.50	< 0.50	< 0.50	< 0.50
trans-1,2-Dichloroethene		< 1.0	--	< 1.0	< 0.50	< 0.50	< 0.50	< 0.50
trans-1,3-Dichloropropene		< 1.0	--	< 1.0	< 0.50	< 0.50	< 0.50	< 0.50
Trichloroethene		< 1.0	--	< 1.0	< 0.50	< 0.50	< 0.50	< 0.50
Vinyl chloride		< 1.0	--	< 1.0	< 0.50	< 0.50	< 0.50	< 0.50
Xylene-o		< 1.0	--	< 1.0	< 0.50	< 0.50	< 0.50	< 0.50
Xylenes- m,p		< 1.0	--	< 1.0	< 0.50	< 0.50	< 0.50	< 0.50
Total VOCs		0		0	0	0	0	0
1,4-Dioxane		--	< 0.200	--	--	--	--	--

See Notes and Abbreviations on last page

Table 19A
Concentrations of Volatile Organic Compounds and
1,4-Dioxane in Blank Samples,
Operable Unit 2, Northrop Grumman Systems Corporation,
Bethpage, New York

Constituents (units in g/L)	Analytical Method Sample ID: Sample Date:	QA/QC	QA/QC	QA/QC	QA/QC	QA/QC	QA/QC
		USEPA Method 8260	USEPA Method 522	USEPA Method 8260	USEPA Method 524.2	USEPA Method 522	USEPA Method 524.2
		TB111317DC1 11/13/2017	FB111317DC1 11/13/2017	FB111317DC1 11/13/2017	TB111417AD1 11/14/2017	FB111417AD1 11/14/2017	FB111417AD1 11/14/2017
1,1,1-Trichloroethane		< 1.0	--	< 1.0	< 0.50	--	< 0.50
1,1,2,2-Tetrachloroethane		< 1.0	--	< 1.0	< 0.50	--	< 0.50
1,1,2-trichloro-1,2,2-trifluoroethane		< 5.0	--	< 5.0	< 1.0	--	< 1.0
1,1,2-Trichloroethane		< 1.0	--	< 1.0	< 0.50	--	< 0.50
1,1-Dichloroethane		< 1.0	--	< 1.0	< 0.50	--	< 0.50
1,1-Dichloroethene		< 1.0	--	< 1.0	< 0.50	--	< 0.50
1,2-Dichloroethane		< 1.0	--	< 1.0	< 0.50	--	< 0.50
1,2-Dichloropropane		< 1.0	--	< 1.0	< 0.50	--	< 0.50
2-Butanone (MEK)		< 10	--	< 10	< 5.0	--	< 5.0
4-Methyl-2-Pentanone		< 5.0	--	< 5.0	< 2.0	--	< 2.0
Acetone		< 10	--	< 10	< 5.0	--	< 5.0
Benzene		< 0.50	--	< 0.50	< 0.50	--	< 0.50
Bromodichloromethane		< 1.0	--	< 1.0	< 0.50	--	< 0.50
Bromoform		< 1.0	--	< 1.0	< 0.50	--	< 0.50
Bromomethane		< 2.0	--	< 2.0	< 0.50	--	< 0.50
Carbon Disulfide		< 2.0	--	< 2.0	< 0.50	--	< 0.50
Carbon Tetrachloride		< 1.0	--	< 1.0	< 0.50	--	< 0.50
Chlorobenzene		< 1.0	--	< 1.0	< 0.50	--	< 0.50
Chlorodibromomethane		< 1.0	--	< 1.0	< 0.50	--	< 0.50
Chloroethane		< 1.0	--	< 1.0	< 0.50	--	< 0.50
Chloroform		< 1.0	--	< 1.0	< 0.50	--	< 0.50
Chloromethane		< 1.0	--	< 1.0	< 0.50	--	< 0.50
cis-1,2-Dichloroethene		< 1.0	--	< 1.0	< 0.50	--	< 0.50
cis-1,3-Dichloropropene		< 1.0	--	< 1.0	< 0.50	--	< 0.50
Ethylbenzene		< 1.0	--	< 1.0	< 0.50	--	< 0.50
Methyl N-Butyl Ketone (2-Hexanone)		< 5.0	--	< 5.0	< 2.0	--	< 2.0
Methylene Chloride		< 2.0	--	< 2.0	< 0.50	--	< 0.50
Styrene (Monomer)		< 1.0	--	< 1.0	< 0.50	--	< 0.50
Tetrachloroethene		< 1.0	--	< 1.0	< 0.50	--	< 0.50
Toluene		< 1.0	--	< 1.0	< 0.50	--	< 0.50
trans-1,2-Dichloroethene		< 1.0	--	< 1.0	< 0.50	--	< 0.50
trans-1,3-Dichloropropene		< 1.0	--	< 1.0	< 0.50	--	< 0.50
Trichloroethene		< 1.0	--	< 1.0	< 0.50	--	< 0.50
Vinyl chloride		< 1.0	--	< 1.0	< 0.50	--	< 0.50
Xylene-o		< 1.0	--	< 1.0	< 0.50	--	< 0.50
Xylenes- m,p		< 1.0	--	< 1.0	< 0.50	--	< 0.50
Total VOCs		0		0	0		0
1,4-Dioxane		--	< 0.200	--	--	< 0.200	--

See Notes and Abbreviations on last page

Table 19A
Concentrations of Volatile Organic Compounds and
1,4-Dioxane in Blank Samples,
Operable Unit 2, Northrop Grumman Systems Corporation,
Bethpage, New York

Notes and Abbreviations

Results validated following protocols specified in OU2 Groundwater Monitoring Plan (Arcadis 2016c).
Above analyte list represents aggregation of all VOCs analyzed for using the laboratory methods specified herein.
Total VOCs rounded to two significant figures.

Bold indicates constituent detected

µg/L micrograms per liter

USEPA United States Environmental Protection Agency

TCL Target Compound List

VOCs volatile organic compounds

SIM Selective Ion Monitoring

J Value is estimated concentration

-- Not analyzed.

TB Trip Blank

FB Field Blank

QA/QC Quality Assurance/Quality Control

< 0.50 Compound not detected above its laboratory quantification limit.

OU2 Operable Unit 2

Table 19B
Concentrations of Metals in Blank Samples,
Operable Unit 2, Northrop Grumman Systems Corporation,
Bethpage, New York

Constituents (units in ug/L)	Sample ID:	QA/QC ⁽¹⁾	QA/QC ⁽¹⁾	QA/QC ⁽¹⁾	QA/QC ⁽¹⁾	QA/QC ⁽¹⁾	QA/QC ⁽¹⁾	QA/QC ⁽¹⁾	QA/QC ⁽¹⁾	QA/QC ⁽¹⁾	QA/QC ⁽¹⁾
	Sample Date:	5/5/2017	6/21/2017	6/22/2017	6/23/2017	6/27/2017	6/28/2017	6/29/2017	10/20/2017	11/2/2017	11/13/2017
		< 3.0	--	< 3.0	< 3.0	--	--	< 3.0	--	< 3.0	< 3.0
Cadmium		< 3.0	--	< 3.0	< 3.0	--	--	< 3.0	--	< 3.0	< 3.0
Chromium		< 10	< 10	< 10	< 10	< 10	< 10	< 10	< 10	< 10	< 10

Notes and Abbreviations

(1) Sample analyzed for Metals using USEPA Method 6010C

Results validated following protocols specified in OU2 Groundwater Monitoring Plan (Arcadis 2016c).

- µg/L micrograms per liter
- USEPA United States Environmental Protection Agency
- Not analyzed.
- TB Trip Blank
- FB Field Blank
- QA/QC Quality Assurance/Quality Control
- < 3.0 Compound not detected above its laboratory quantification limit.
- OU2 Operable Unit 2

FIGURES



TOWER 96 TREATMENT SYSTEM:

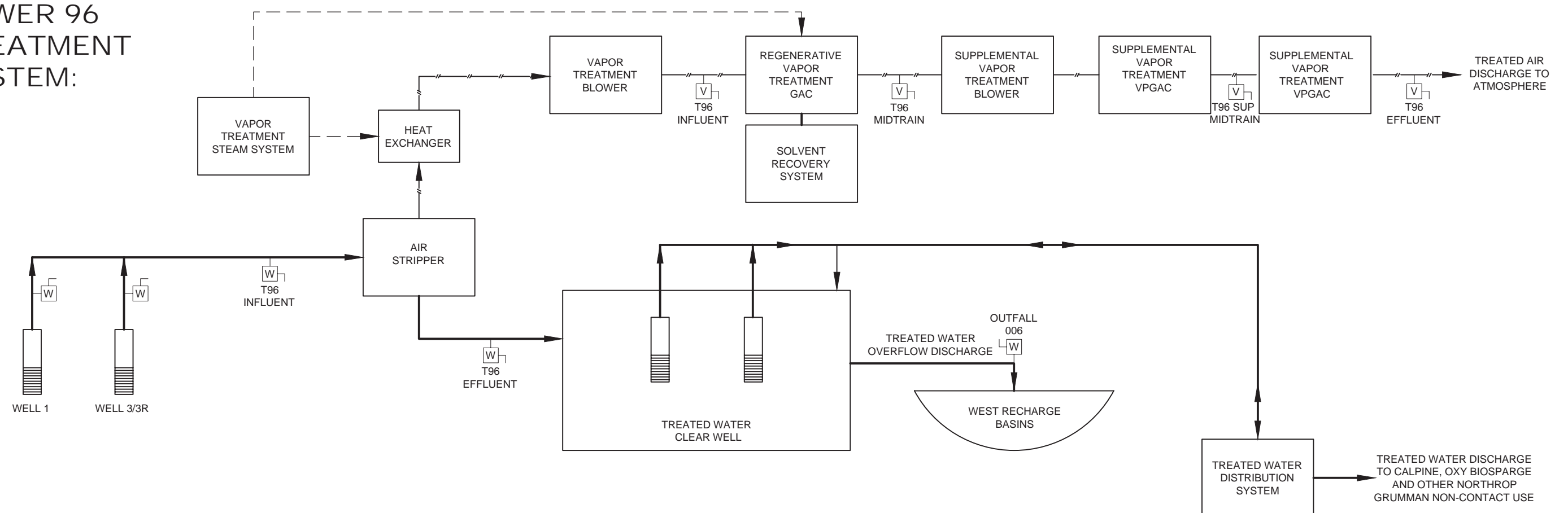

TOWER 102 TREATMENT SYSTEM:

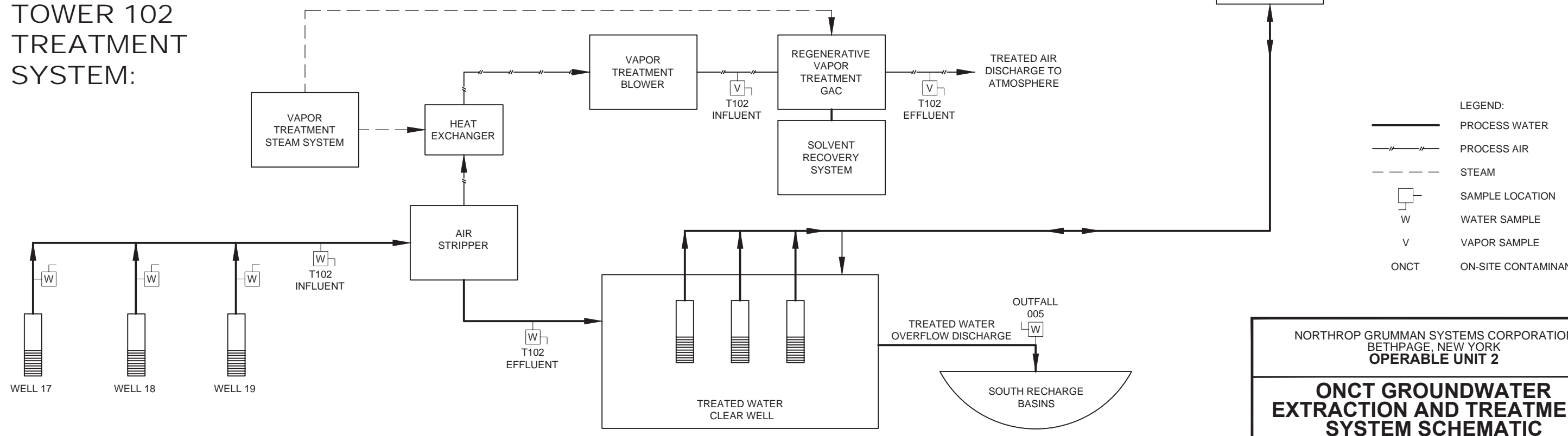

- LEGEND:
- PROCESS WATER
 - - - PROCESS AIR
 - - - - STEAM
 - W SAMPLE LOCATION
 - W WATER SAMPLE
 - V VAPOR SAMPLE
 - ONCT ON-SITE CONTAMINANT

NORTHROP GRUMMAN SYSTEMS CORPORATION
BETHPAGE, NEW YORK
OPERABLE UNIT 2

**ONCT GROUNDWATER
EXTRACTION AND TREATMENT
SYSTEM SCHEMATIC**

ARCADIS Design & Consultancy
for natural and
built assets

FIGURE
3

CITY: SYRACUSE, NY DIV: GROUPE NV DB: A. SANCHEZ LD: ALS PIC: (Regd) TM: (Opt) LYR: (Opt) ON: -OFF- REF: (PATRICIA RICHE PDF CHANGES SUP BED TEXT and extra VSP-10.26.17)
 G:\ENV\CAD\SYRACUSE\ACT\NY0014961414\G\MMH14961414\F03.dwg LAYOUT: 3 SAVED: 3/15/2016 10:09 AM ACADVER: 19.1.5 (LMS TECH) PAGES: 3 PLOT: PLT FULL CTB BY: SANCHEZ, ADRIAN
 XREFS: IMAGES: PROJECTNAME:

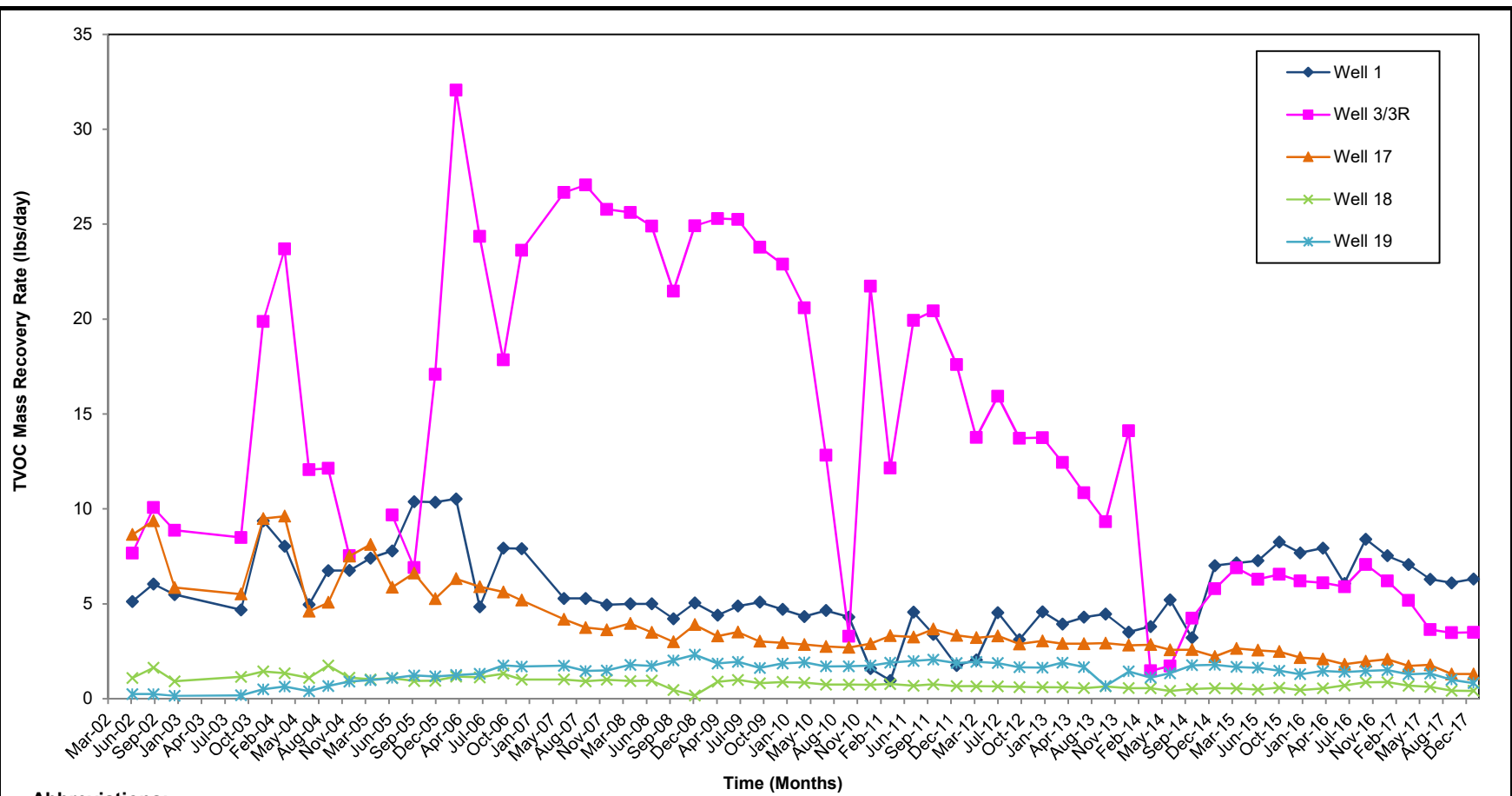

Abbreviations:

VOC = Volatile Organic Compound.
 lbs/day = Pounds per day.
 TVOCs = Sum of VOCs detected

NORTHROP GRUMMAN SYSTEMS CORPORATION BETHPAGE, NEW YORK OU2 ON-SITE GROUNDWATER REMEDY	
REMEDIAL WELLS TOTAL VOC MASS RECOVERY RATES THROUGH DECEMBER 2017	
 ARCADIS <small>Design & Consultancy for natural and built assets</small>	FIGURE 4

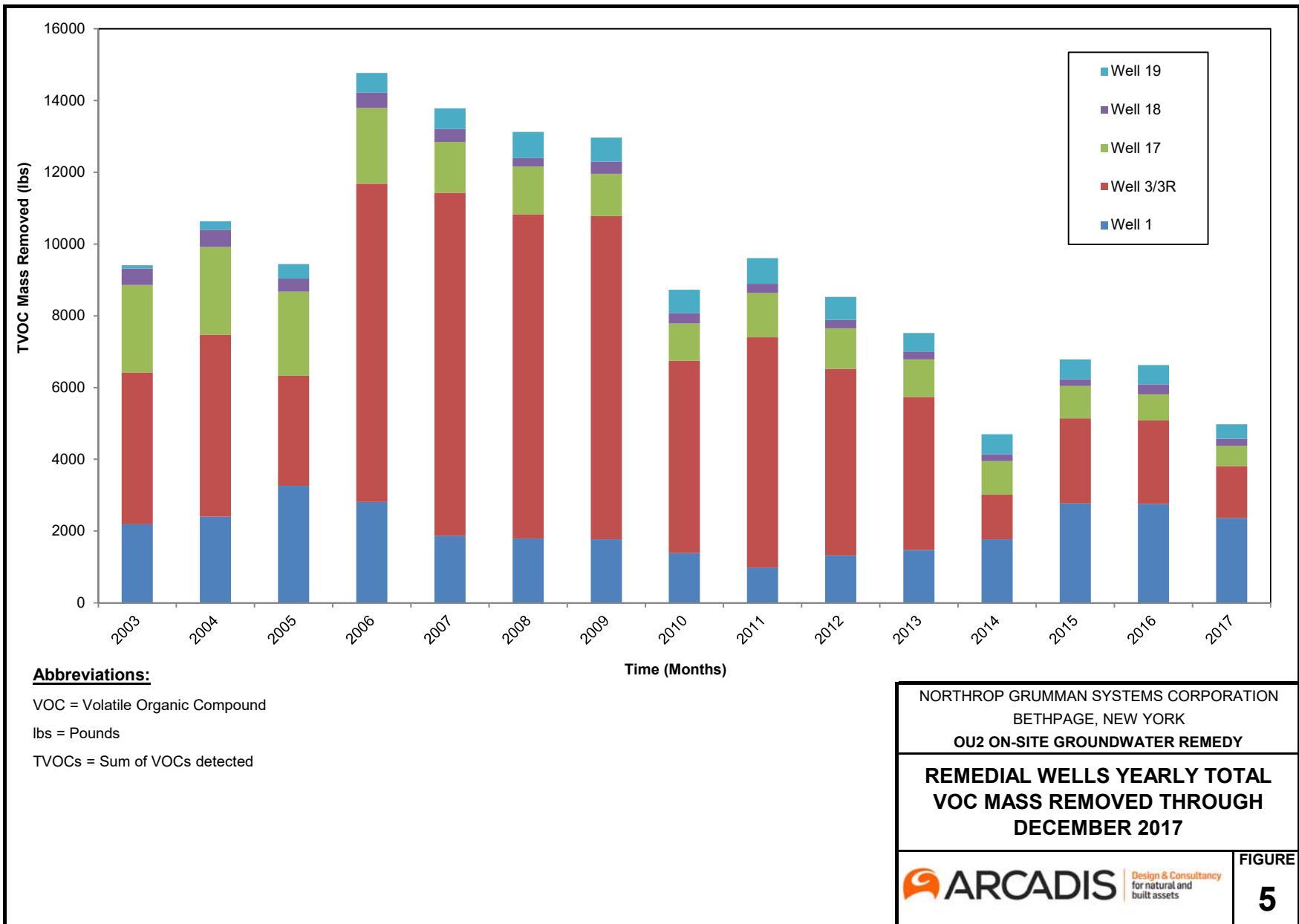

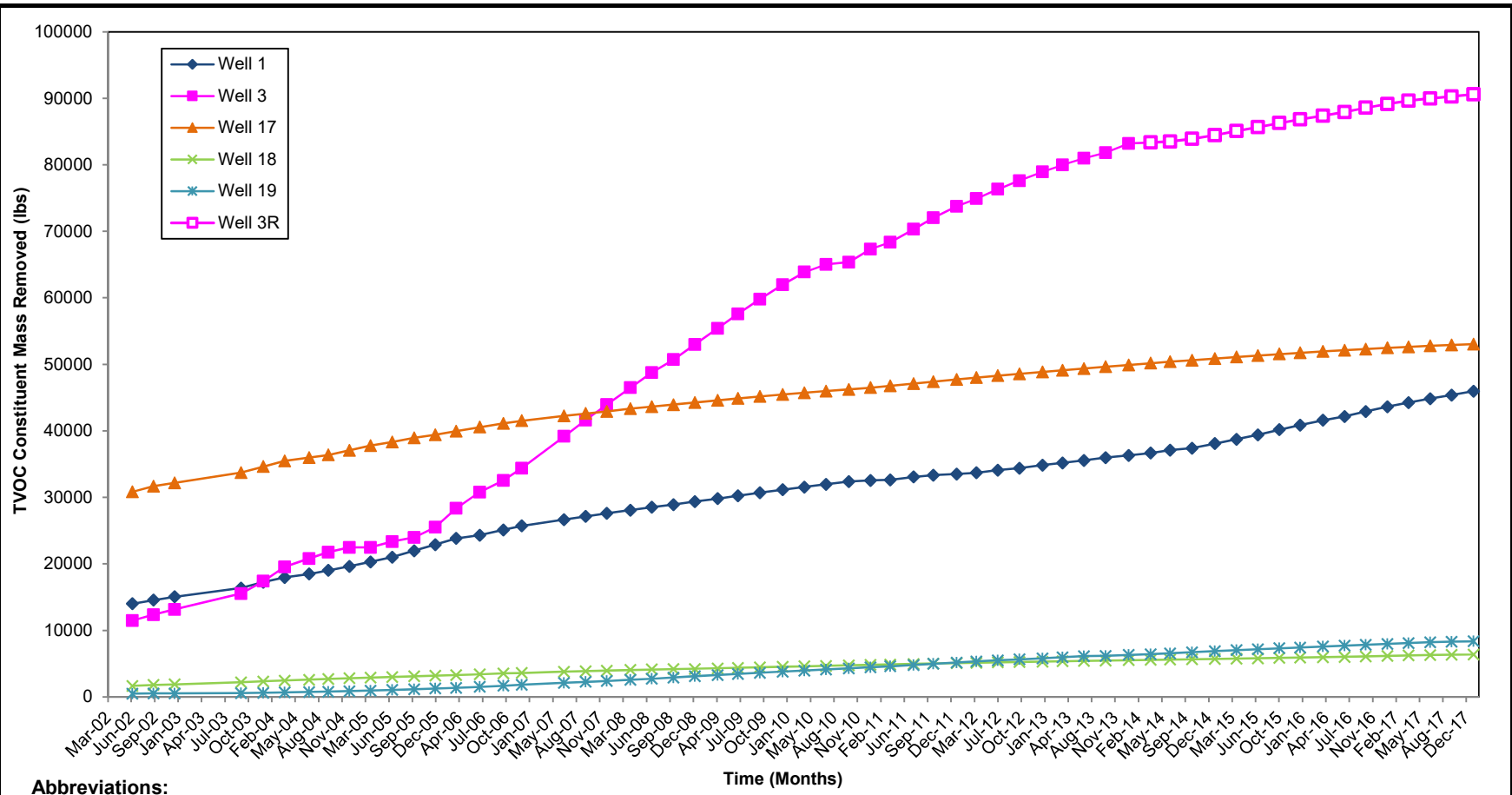

Abbreviations:

VOC = Volatile Organic Compound
 lbs = Pounds
 TVOCs = Sum of VOCs detected
 ONCT = On-Site Containment

Notes:

1. Cumulative Total VOC Mass Removed includes mass removed since startup of the ONCT system in September 1998.

NORTHROP GRUMMAN SYSTEMS CORPORATION BETHPAGE, NEW YORK OU2 ON-SITE GROUNDWATER REMEDY	
REMEDIAL WELLS CUMULATIVE TOTAL VOC MASS REMOVED THROUGH DECEMBER 2017	
	<small>Design & Consultancy for natural and built assets</small>
FIGURE 6	

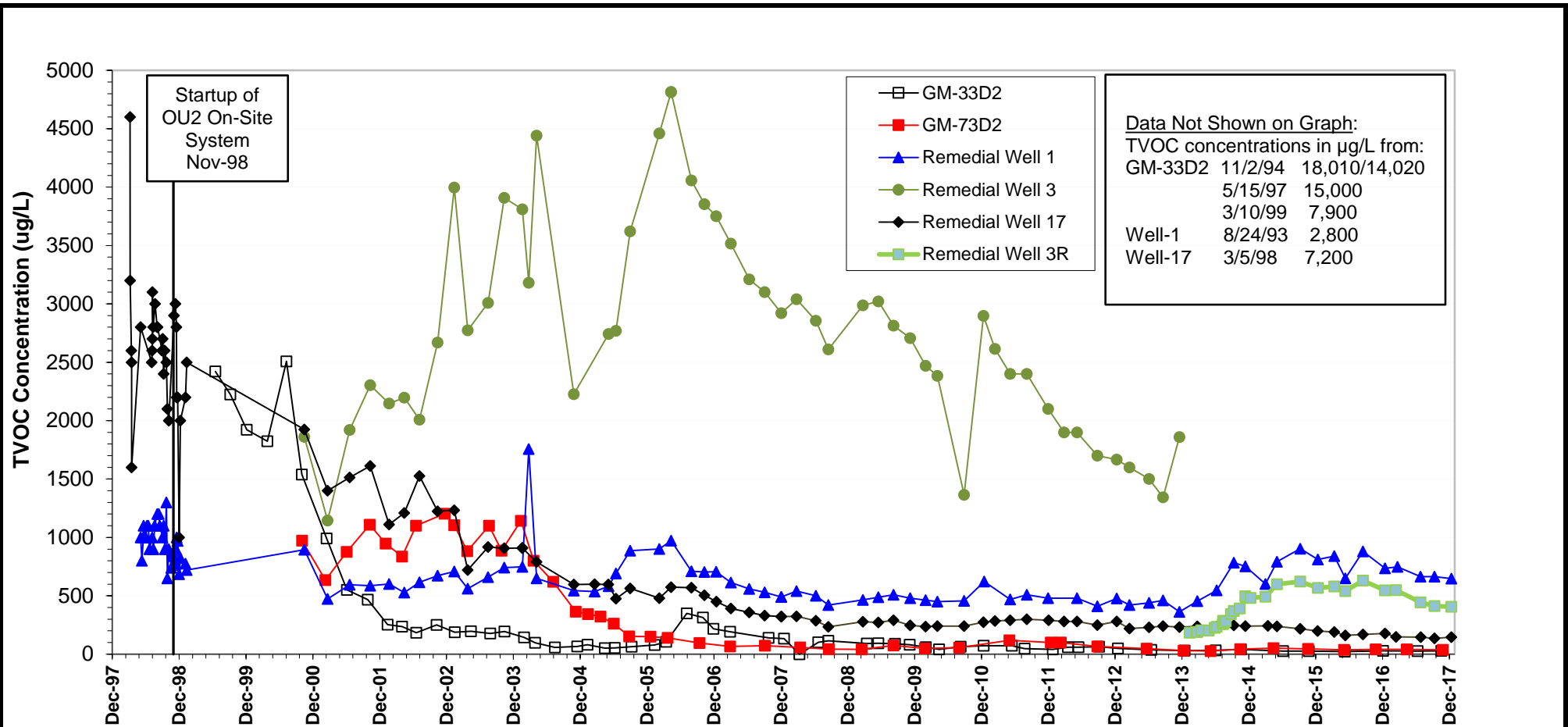

Startup of
OU2 On-Site
System
Nov-98

- GM-33D2
- GM-73D2
- ▲ Remedial Well 1
- Remedial Well 3
- ◆ Remedial Well 17
- Remedial Well 3R

Data Not Shown on Graph:
TVOC concentrations in µg/L from:

GM-33D2	11/2/94	18,010/14,020
	5/15/97	15,000
	3/10/99	7,900
Well-1	8/24/93	2,800
Well-17	3/5/98	7,200

Abbreviation:
 TVOC = Total Volatile organic compound
 Total VOCs = Sum of VOCs detected
 µg/L = micrograms per liter

NORTHROP GRUMMAN SYSTEMS CORPORATION
 BETHPAGE, NEW YORK
 OPERABLE UNIT 2

**Total Volatile Organic Compound
 Concentrations (Southern and Southwestern
 Site Boundary) in On-Site Deep 2 Monitoring
 Wells and OU2 Remedial Wells**

ARCADIS Design & Consultancy
 for natural and built assets

FIGURE 7

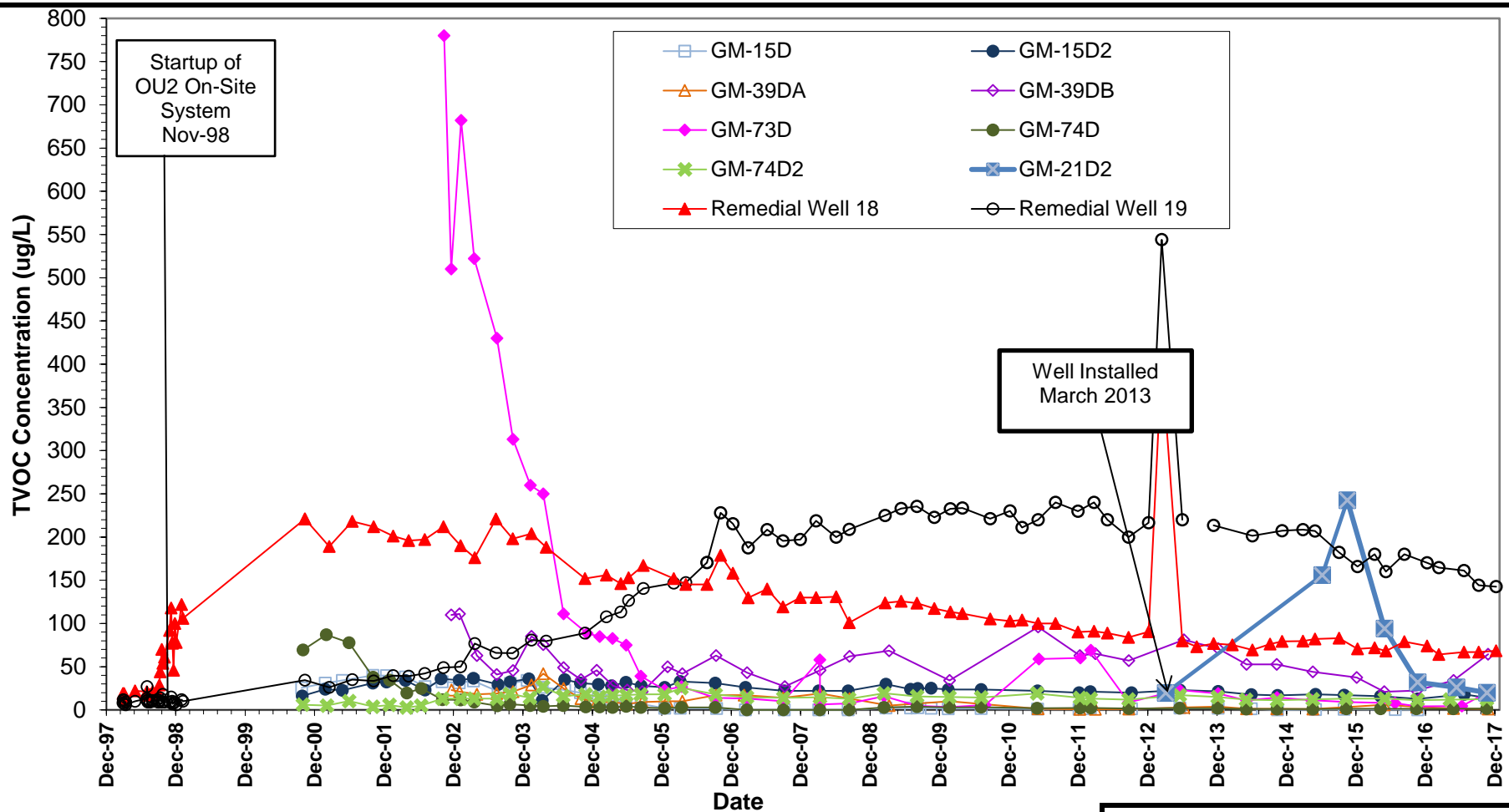

Abbreviation:

TVOC = Total Volatile organic compound

Total VOCs = Sum of VOCs detected

µg/L = micrograms per liter

NORTHROP GRUMMAN SYSTEMS CORPORATION
 BETHPAGE, NEW YORK
 OPERABLE UNIT 2

**Total Volatile Organic Compound
 Concentrations (Southern and
 Southeastern Site Boundary) in On-
 site/Near Site Deep and Deep 2 Monitoring
 Wells and OU2 Remedial Wells**

ARCADIS Design & Consultancy
for natural and
built assets

**FIGURE
8**

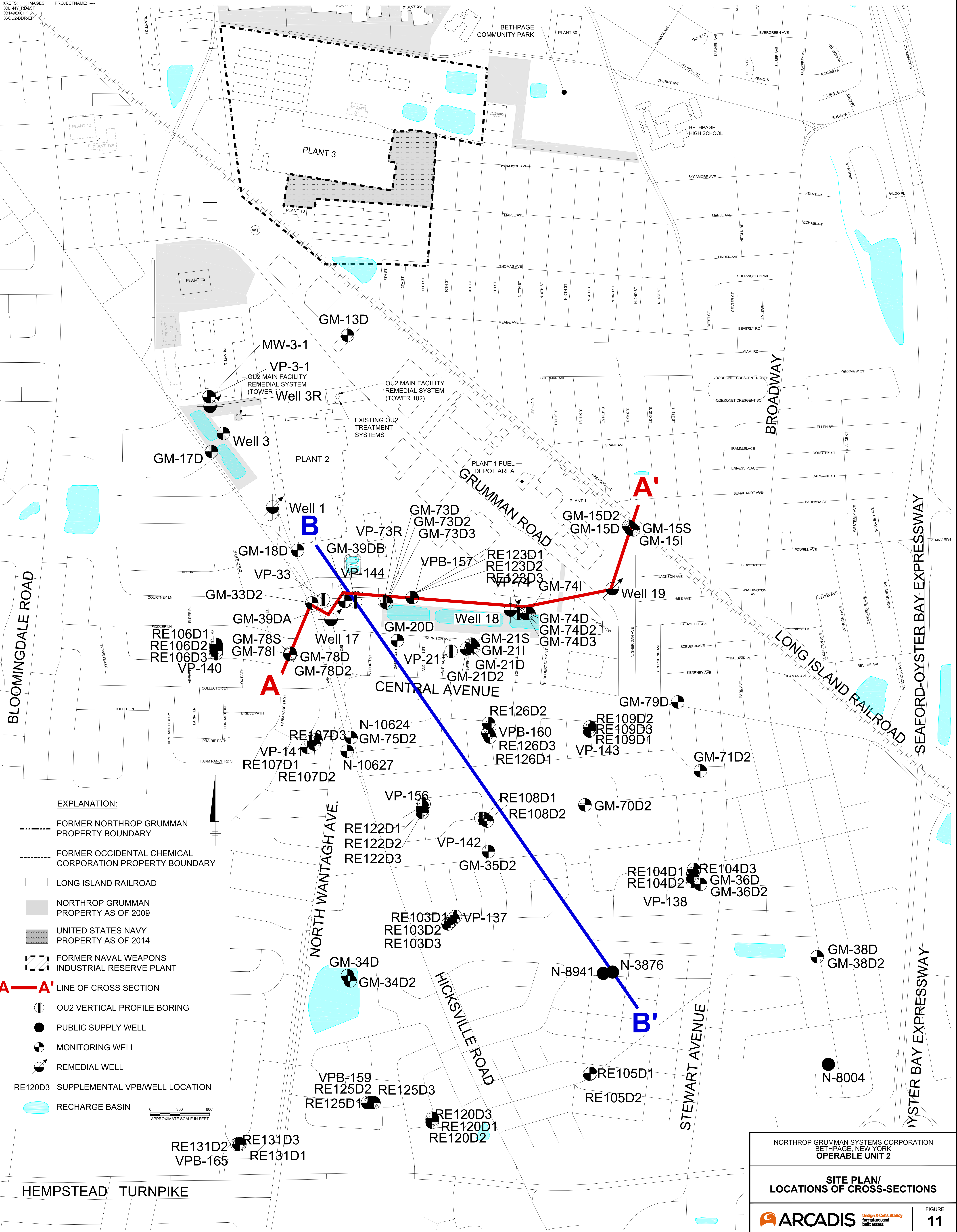

EXPLANATION:

- FORMER NORTHROP GRUMMAN PROPERTY BOUNDARY
- FORMER OCCIDENTAL CHEMICAL CORPORATION PROPERTY BOUNDARY
- ===== LONG ISLAND RAILROAD
- NORTHROP GRUMMAN PROPERTY AS OF 2009
- UNITED STATES NAVY PROPERTY AS OF 2014
- ▨ FORMER NAVAL WEAPONS INDUSTRIAL RESERVE PLANT
- A—A'** LINE OF CROSS SECTION
- OU2 VERTICAL PROFILE BORING
- PUBLIC SUPPLY WELL
- ◐ MONITORING WELL
- ◑ REMEDIAL WELL
- RE120D3 SUPPLEMENTAL VPB/WELL LOCATION
- RECHARGE BASIN

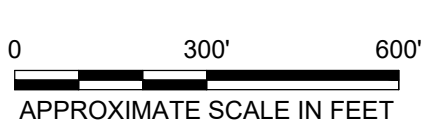

NORTHROP GRUMMAN SYSTEMS CORPORATION BETHPAGE, NEW YORK OPERABLE UNIT 2	
SITE PLAN/ LOCATIONS OF CROSS-SECTIONS	
	Design & Consultancy for natural and built assets
FIGURE	11

WEST A

A' EAST

NORTHROP GRUMMAN SITE

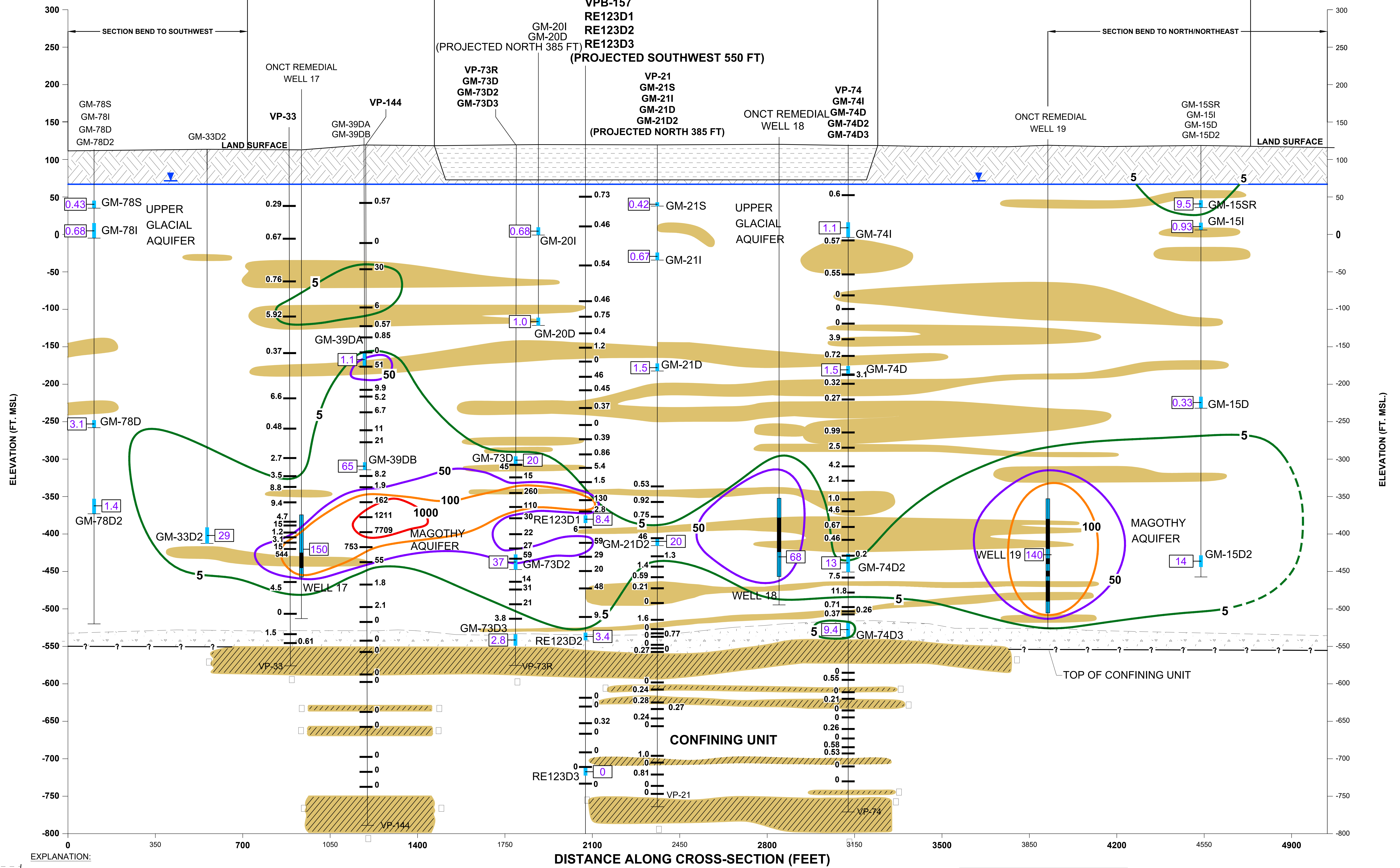

- EXPLANATION:
- RECHARGE BASIN (TYPICAL; NOT TO SCALE)
 - UNSATURATED ZONE
 - APPROXIMATE GROUNDWATER TABLE
 - UNSHADED AREAS REPRESENTS SATURATED AQUIFER MATERIAL WHICH CONSISTS OF SAND WITH VARYING AMOUNTS OF GRAVEL AND SILT AND AT SOME LOCATIONS AND/OR HORIZONS INTERBEDDED LAYERS OF FINE SAND, SILT AND CLAY.
 - CLAYEY SAND, SANDY CLAY, AND CLAY (CONFINING UNITS) WITHIN MAGOTHY AND UPPER GLACIAL AQUIFERS
 - BASAL MAGOTHY: GRANULES, FINE TO VERY COARSE GRAVELS, AND MEDIUM TO COARSE SAND; WHITE AND GRAY
 - CLAY, GRAY, WHITE, YELLOW, PINK OR RED, STIFF WITH HIGH PLASTICITY

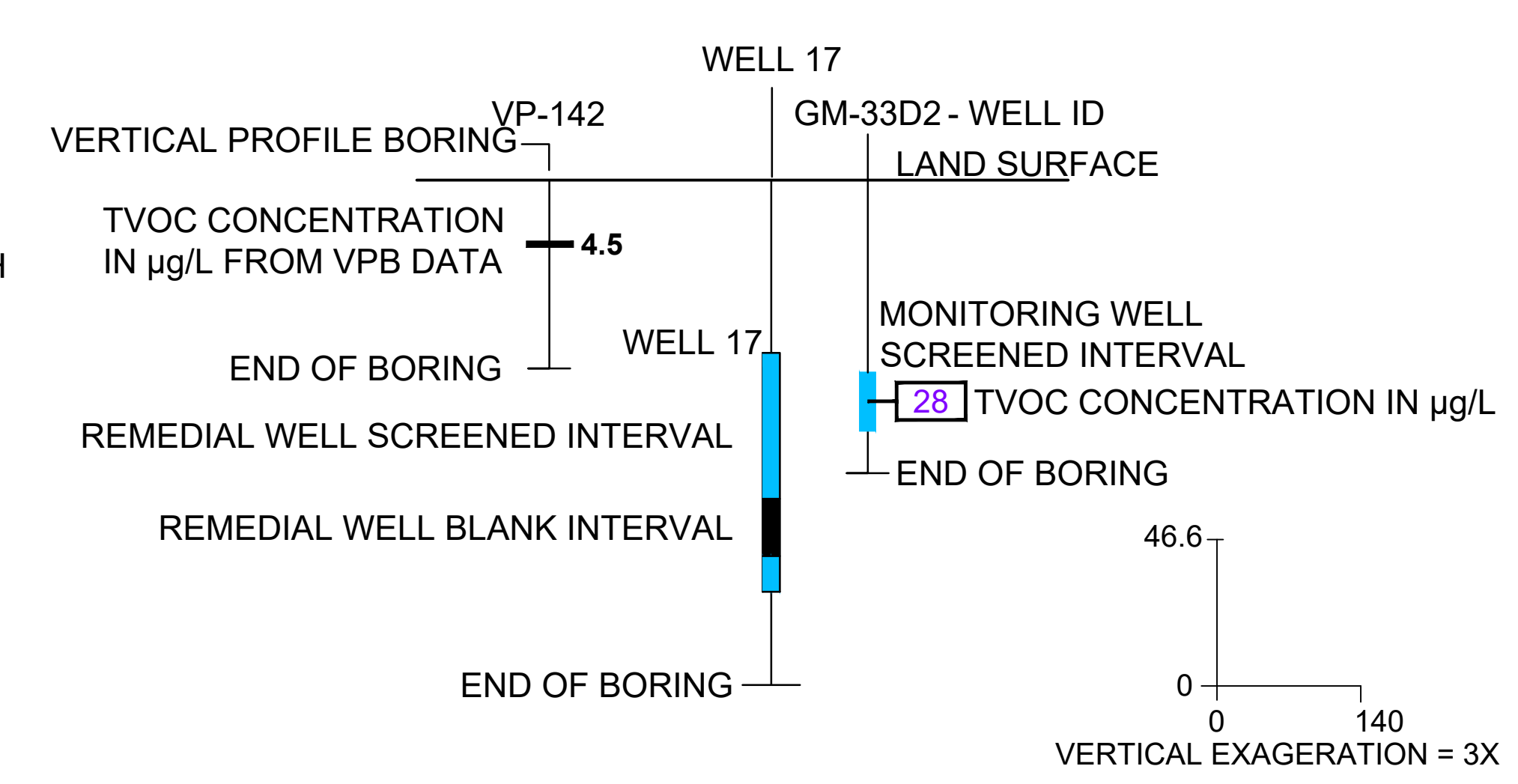

- DEFINITION OF TVOC CONTOURS (DASHED WHERE LESS CONTROL)
- 5 µg/L
 - 50 µg/L
 - 100 µg/L
 - 1,000 µg/L
- MW - MONITORING WELL
 VPB - VERTICAL PROFILE BORING
 FT MSL - FEET RELATIVE TO MEAN SEA LEVEL
 TVOC - TOTAL VOLATILE ORGANIC COMPOUND
 µg/L - MICROGRAMS PER LITER

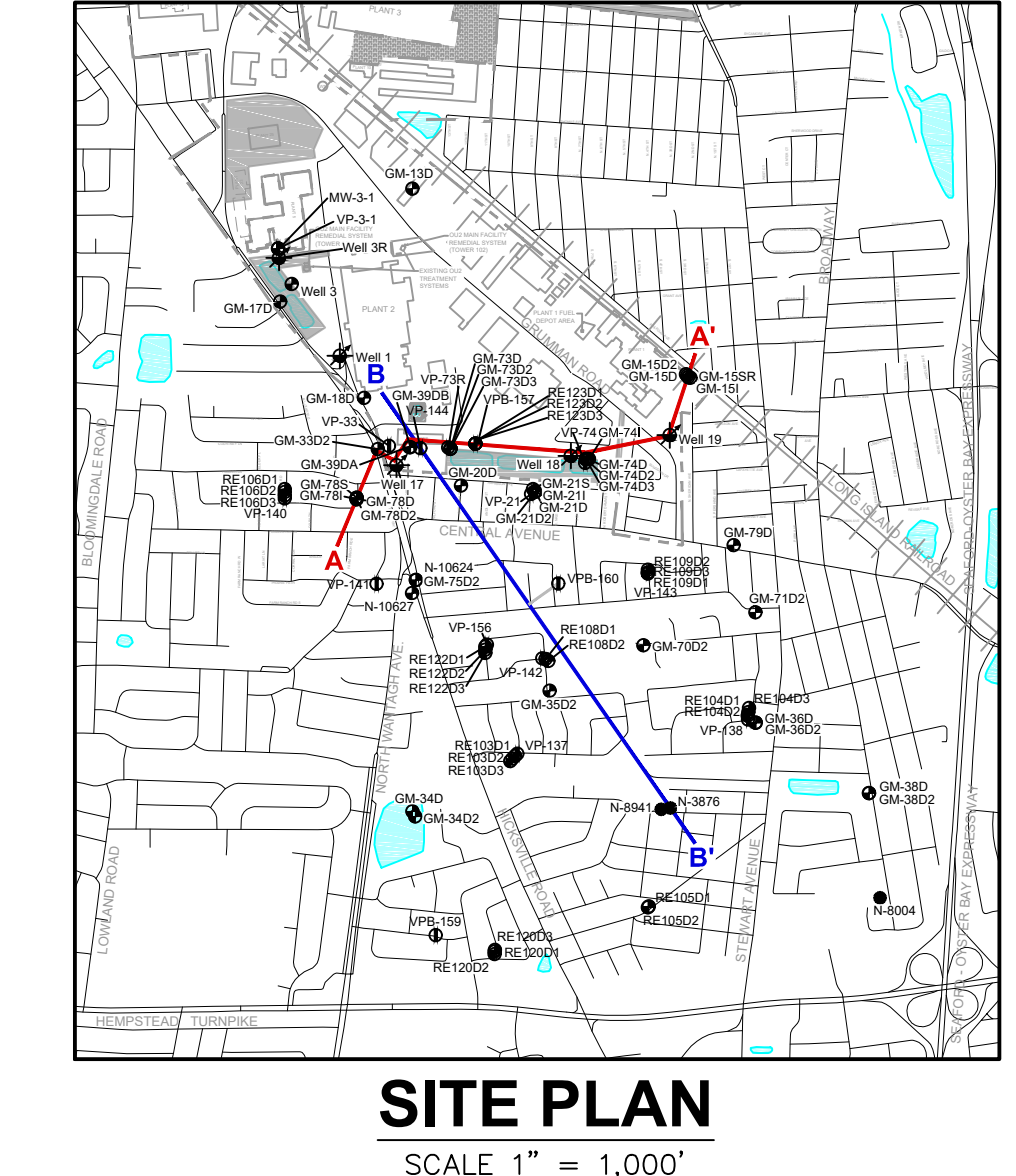

- NOTES:
- HORIZONTAL COMPONENT OF REGIONAL GROUNDWATER FLOW DIRECTION IS TO SOUTH/SOUTHEAST.
 - KNOWN LAB CONTAMINANTS ACETONE, 2-BUTANONE, AND METHYLENE CHLORIDE HAVE BEEN REMOVED FROM ALL VPB AND MW TVOC DATA IF DETECTED IN SAMPLE.
 - ONCT REMEDIAL WELLS 17, 18 AND 19 PUMP AT APPROXIMATELY 1,000 GPM, 500 GPM AND 500 GPM, RESPECTIVELY. SOUTH RECHARGE BASINS RECEIVE APPROXIMATELY 2,300 GPM OF TREATED GROUNDWATER FROM ONCT SYSTEM.

NORTHROP GRUMMAN SYSTEMS CORPORATION
 BETHPAGE, NEW YORK
OPERABLE UNIT 2

CROSS-SECTION A-A'
TVOCs IN GROUNDWATER
2016

ARCADIS
 Design & Consultancy
 for natural and built assets

FIGURE
12

CITY OF BETHPAGE: ENVIRONMENTAL DIVISION, 100 SOUTH BETHPAGE AVENUE, BETHPAGE, NY 11709-1000. PROJECT: 3/20/18 11:38 AM. ADAPTER: 2 (8) (L&R) TECH. PAGES: 12. PLOTTED: 3/20/18 11:38 AM. BY: SANCHEZ, ARIAN.

NORTHWEST B

B' SOUTHEAST

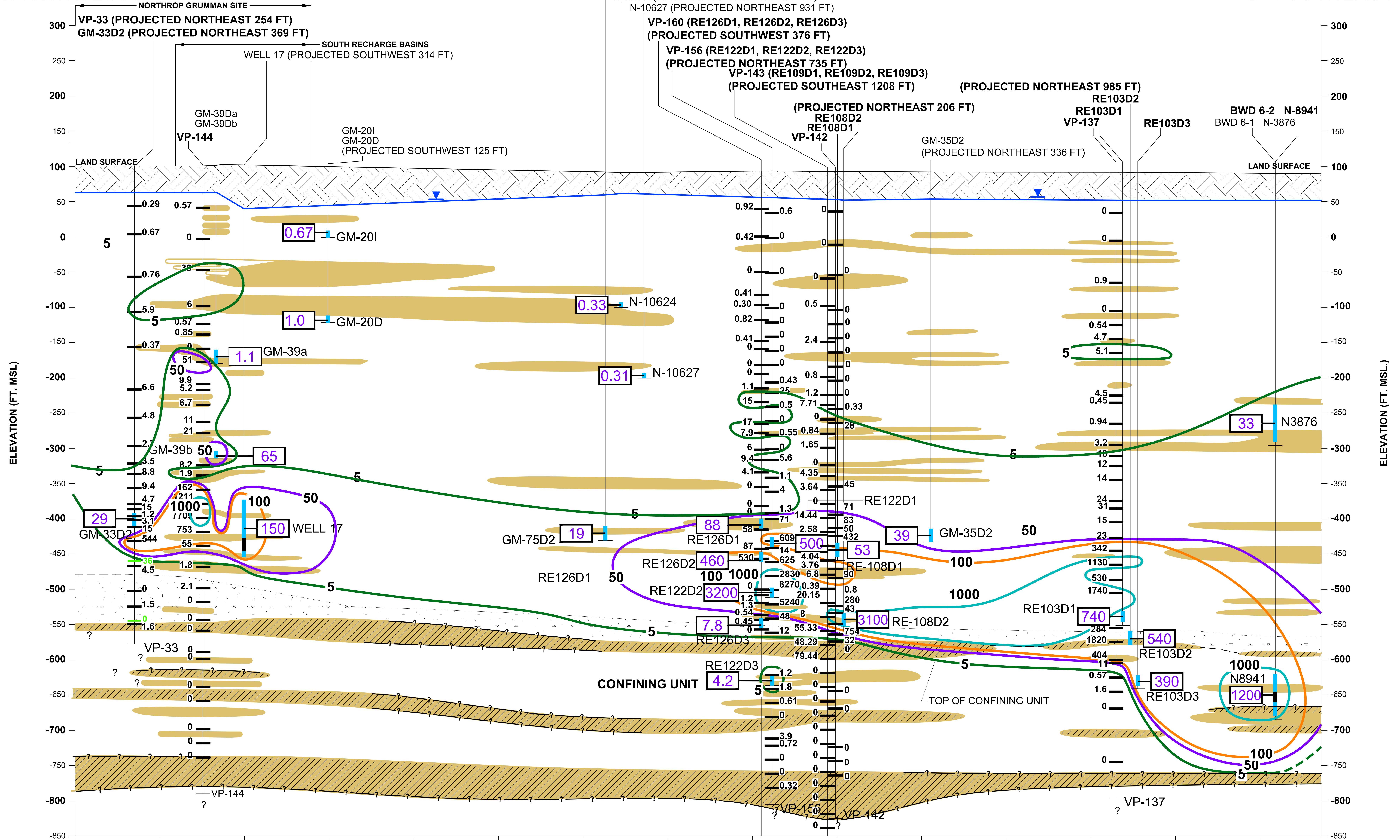

- EXPLANATION:**
- UNSATURATED ZONE
 - APPROXIMATE GROUNDWATER TABLE
 - UNSHADED AREAS REPRESENTS SATURATED AQUIFER MATERIAL WHICH CONSISTS OF SAND WITH VARYING AMOUNTS OF GRAVEL AND SILT AND AT SOME LOCATIONS AND/OR HORIZONS INTERBEDDED LAYERS OF FINE SAND, SILT AND CLAY.
 - CLAYEY SAND, SANDY CLAY, AND CLAY (CONFINING UNITS) WITHIN MAGOTHY AND UPPER GLACIAL AQUIFERS
 - BASAL MAGOTHY: GRANULES, FINE TO VERY COARSE GRAVELS, AND MEDIUM TO COARSE SAND; WHITE AND GRAY
 - CLAY, GRAY, WHITE, YELLOW, PINK OR RED, STIFF WITH HIGH PLASTICITY

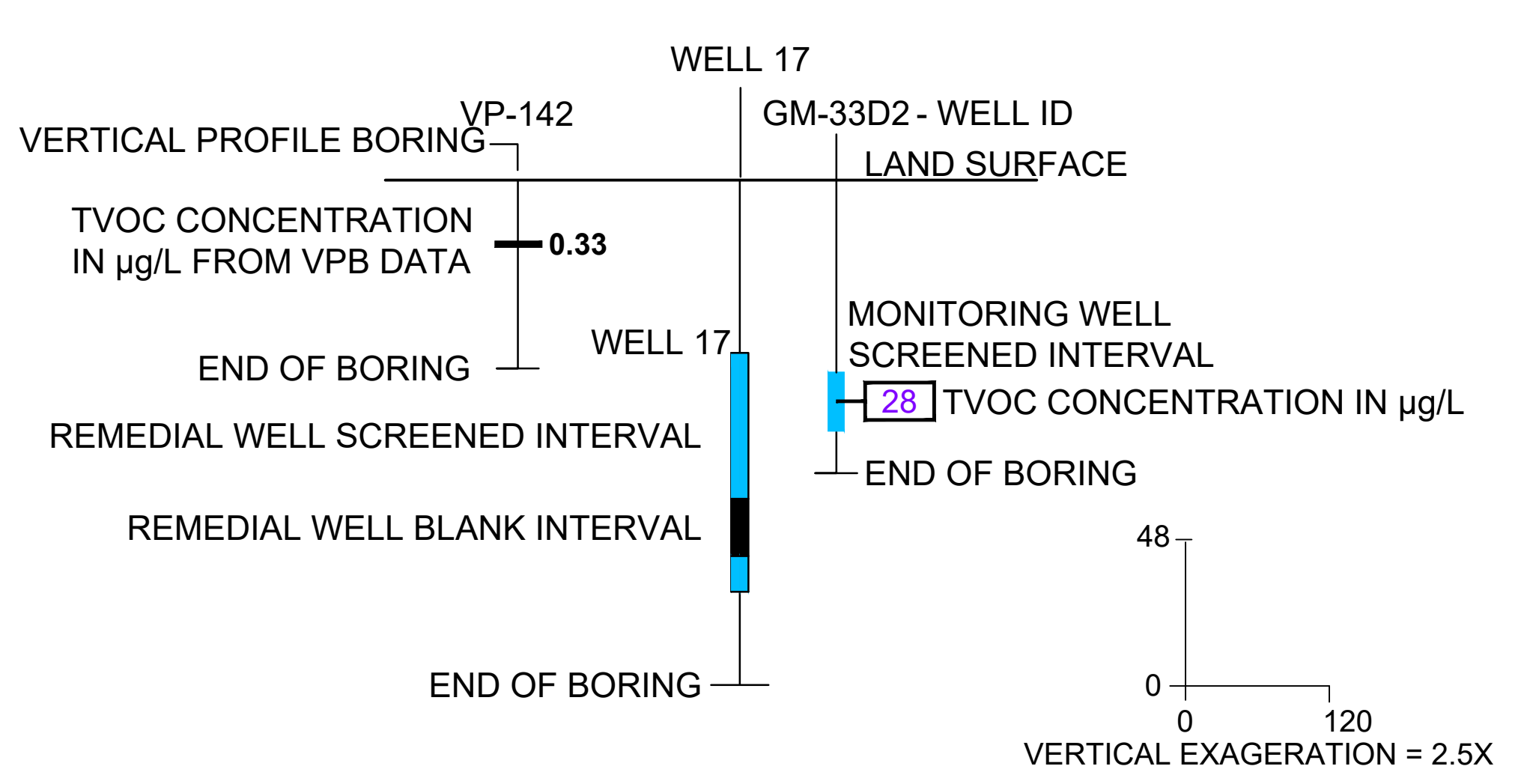

- DEFINITION OF TVOC CONTOURS (DASHED WHERE LESS CONTROL)**
- 5 µg/L
 - 50 µg/L
 - 100 µg/L
 - 1,000 µg/L
 - 5,000 µg/L
- MW - MONITORING WELL
 VPB - VERTICAL PROFILE BORING
 FT MSL - FEET RELATIVE TO MEAN SEA LEVEL
 TVOC - TOTAL VOLATILE ORGANIC COMPOUND
 µg/L - MICROGRAMS PER LITER

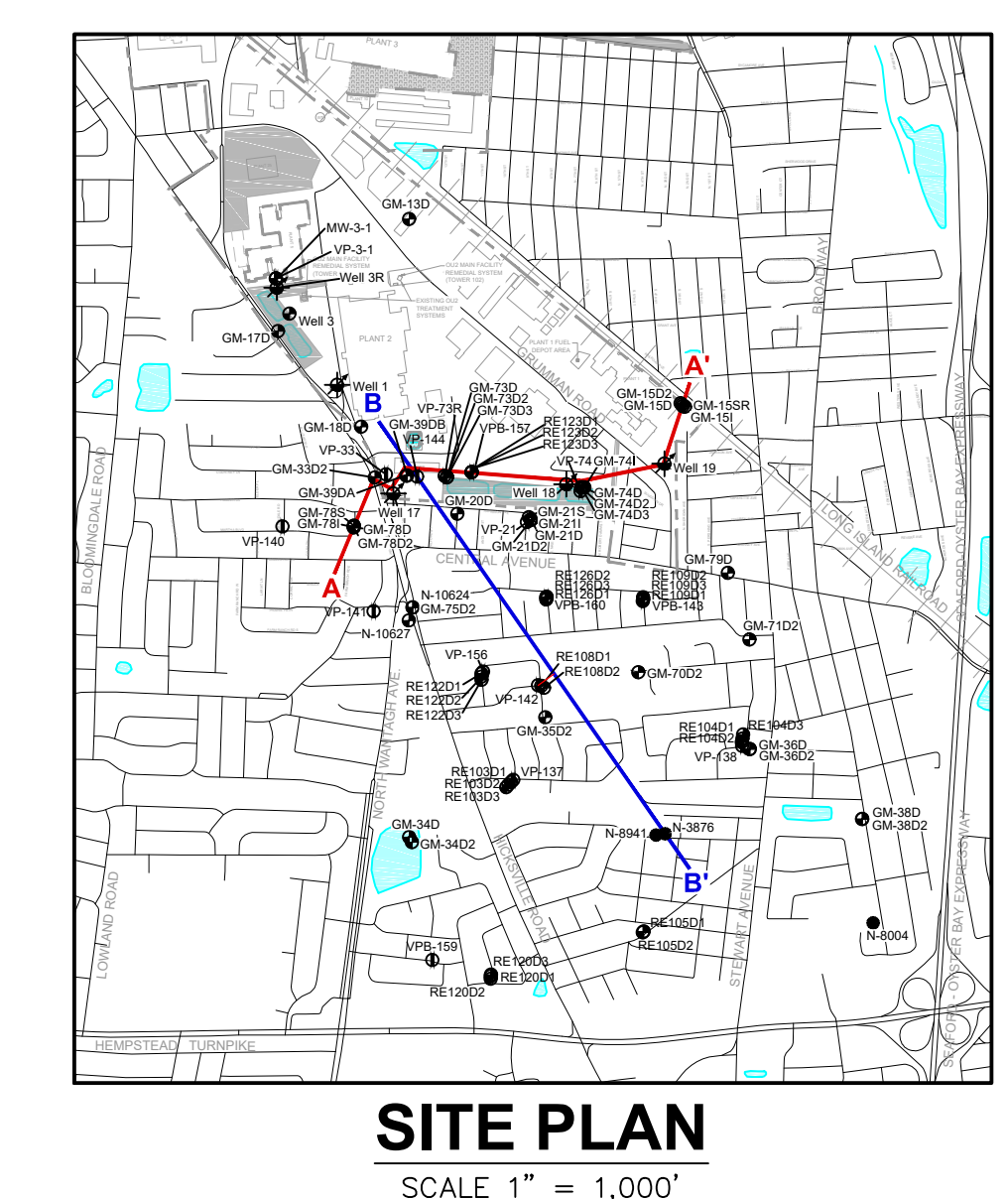

- NOTES:**
1. HORIZONTAL COMPONENT OF REGIONAL GROUNDWATER FLOW DIRECTION IS TO SOUTH/SOUTHEAST.
 2. MONITORING WELL TVOC DATA COLLECTED IN 2016. MOST RECENT ANALYTICAL RESULTS SHOWN.
 3. KNOWN LAB CONTAMINANTS ACETONE, 2 BUTANONE, AND METHYLENE CHLORIDE HAVE BEEN REMOVED FROM ALL VPB AND MW TVOC DATA IF DETECTED IN SAMPLE.
 4. ONCT REMEDIAL WELLS 17, 18 AND 19 PUMP AT APPROXIMATELY 1,000 GPM, 600 GPM AND 700 GPM, RESPECTIVELY. SOUTH RECHARGE BASINS RECEIVE APPROXIMATELY 2,300 GPM OF TREATED GROUNDWATER FROM ONCT SYSTEM.
 5. WHERE VPB LOCATION IS CO-LOCATED WITH A MONITORING WELL, THE TVOC CONCENTRATION OF THE MONITORING WELL IS USED FOR CONTOURING.

NORTHROP GRUMMAN SYSTEMS CORPORATION
 BETHPAGE, NEW YORK
OPERABLE UNIT 2

**CROSS-SECTION B-B'
 TVOCs IN GROUNDWATER
 2017**

ARCADIS Design & Consultancy
for natural and
built assets

FIGURE
13

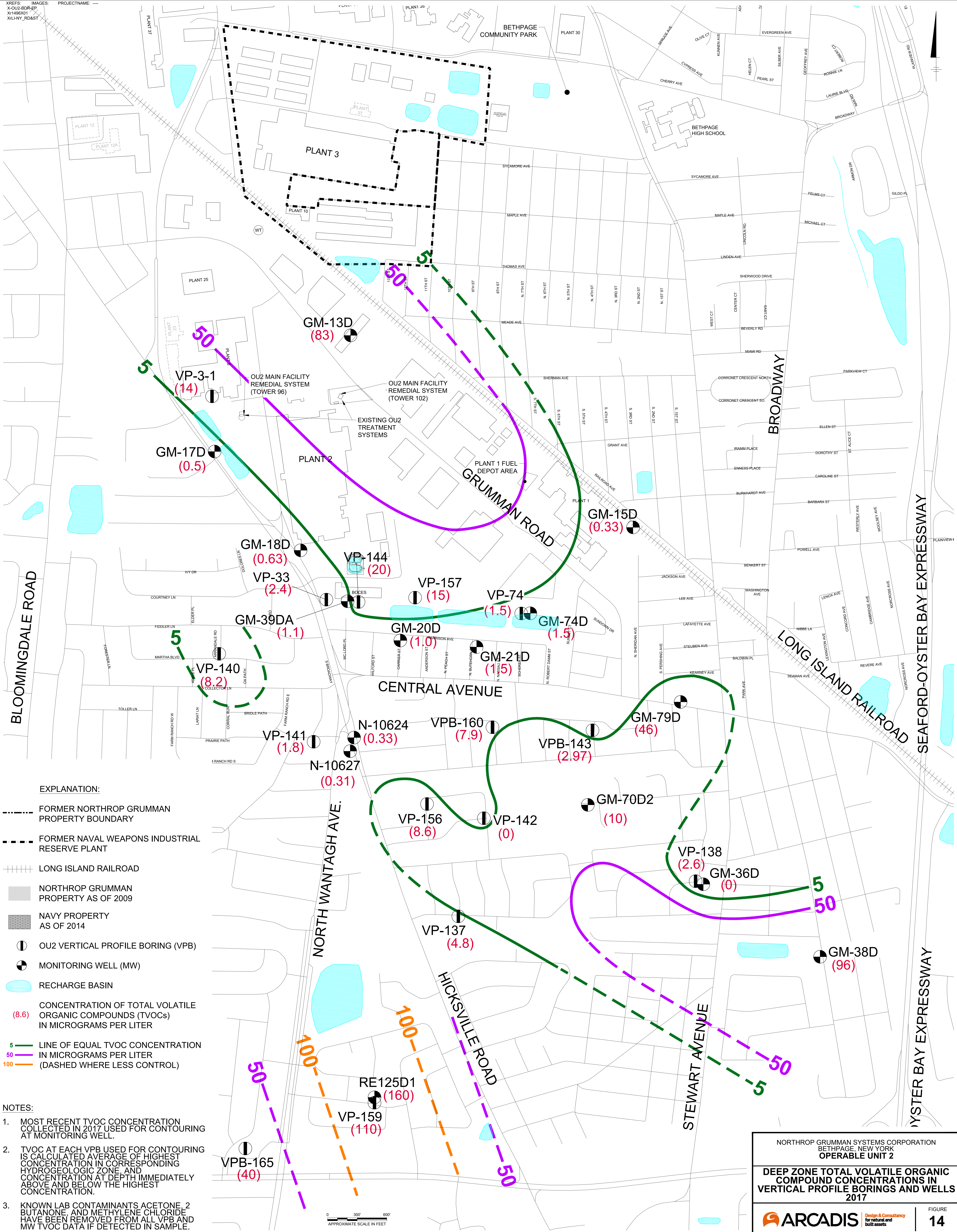

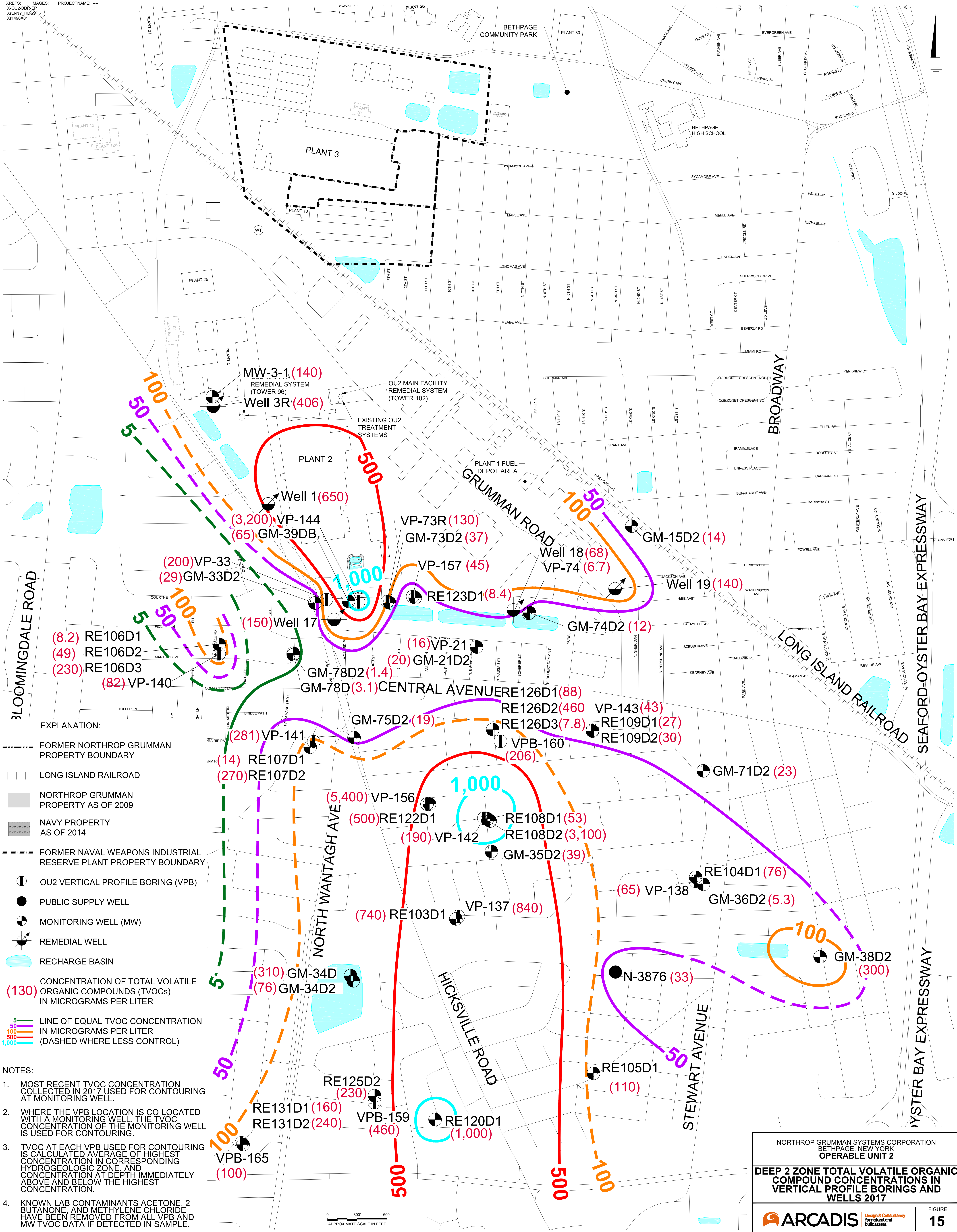

XREFS: IMAGES: PROJECTNAME: ---
 X:OU2-8DR-EP
 X:LLAY: RD382F
 X:1496X01

- EXPLANATION:**
- FORMER NORTHROP GRUMMAN PROPERTY BOUNDARY
 - +++++ LONG ISLAND RAILROAD
 - NORTHROP GRUMMAN PROPERTY AS OF 2009
 - NAVY PROPERTY AS OF 2014
 - FORMER NAVAL WEAPONS INDUSTRIAL RESERVE PLANT PROPERTY BOUNDARY
 - OU2 VERTICAL PROFILE BORING (VPB)
 - PUBLIC SUPPLY WELL
 - MONITORING WELL (MW)
 - REMEDIAL WELL
 - RECHARGE BASIN
 - (130) CONCENTRATION OF TOTAL VOLATILE ORGANIC COMPOUNDS (TVOCs) IN MICROGRAMS PER LITER
 - 5 LINE OF EQUAL TVOC CONCENTRATION IN MICROGRAMS PER LITER (DASHED WHERE LESS CONTROL)
 - 100
 - 500
 - 1,000

- NOTES:**
1. MOST RECENT TVOC CONCENTRATION COLLECTED IN 2017 USED FOR CONTOURING AT MONITORING WELL.
 2. WHERE THE VPB LOCATION IS CO-LOCATED WITH A MONITORING WELL, THE TVOC CONCENTRATION OF THE MONITORING WELL IS USED FOR CONTOURING.
 3. TVOC AT EACH VPB USED FOR CONTOURING IS CALCULATED AVERAGE OF HIGHEST CONCENTRATION IN CORRESPONDING HYDROGEOLOGIC ZONE, AND CONCENTRATION AT DEPTH IMMEDIATELY ABOVE AND BELOW THE HIGHEST CONCENTRATION.
 4. KNOWN LAB CONTAMINANTS ACETONE, 2 BUTANONE, AND METHYLENE CHLORIDE HAVE BEEN REMOVED FROM ALL VPB AND MW TVOC DATA IF DETECTED IN SAMPLE.

NORTHROP GRUMMAN SYSTEMS CORPORATION
 BETHPAGE, NEW YORK
OPERABLE UNIT 2

DEEP 2 ZONE TOTAL VOLATILE ORGANIC COMPOUND CONCENTRATIONS IN VERTICAL PROFILE BORINGS AND WELLS 2017

ARCADIS Design & Consultancy for natural and built assets

FIGURE
15

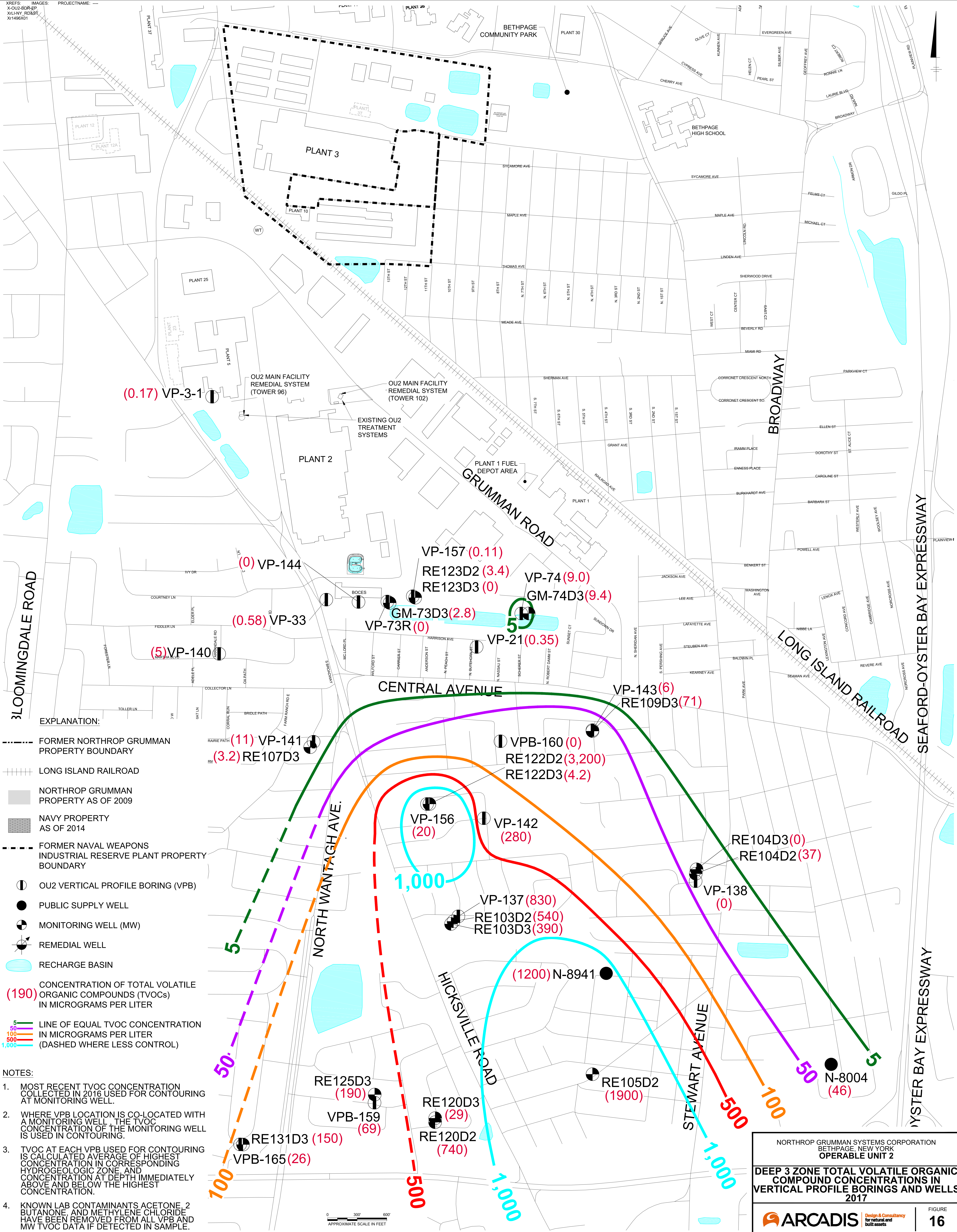

**LAYER 5
(280-355 ft bls)**

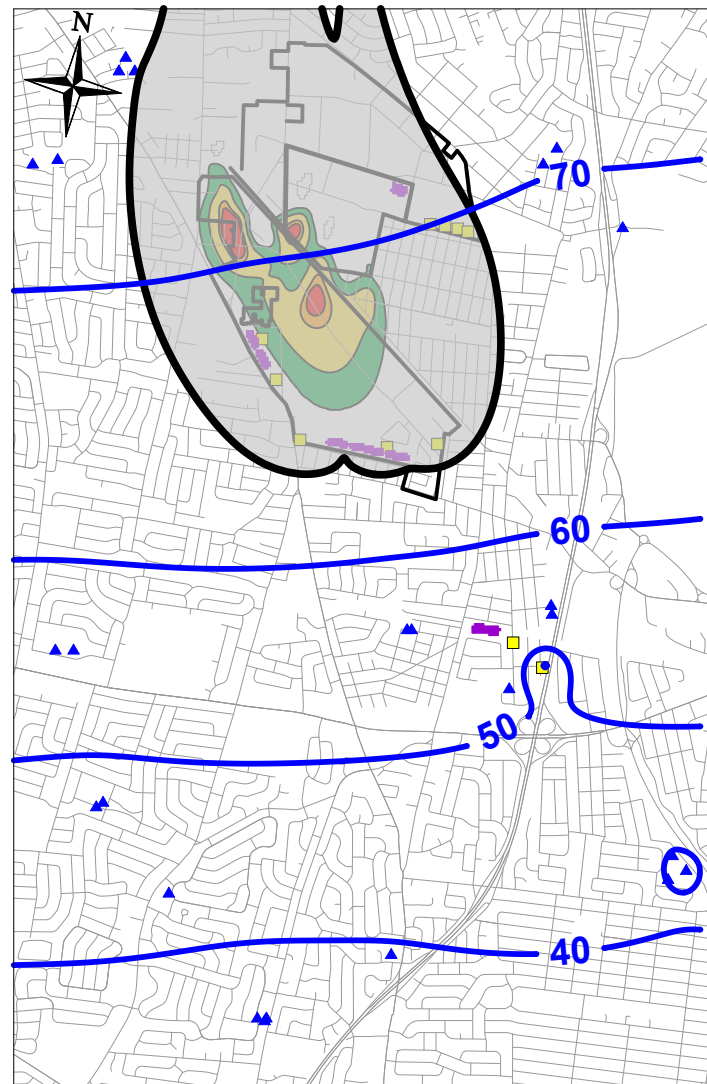

**LAYER 6
(355-430 ft bls)**

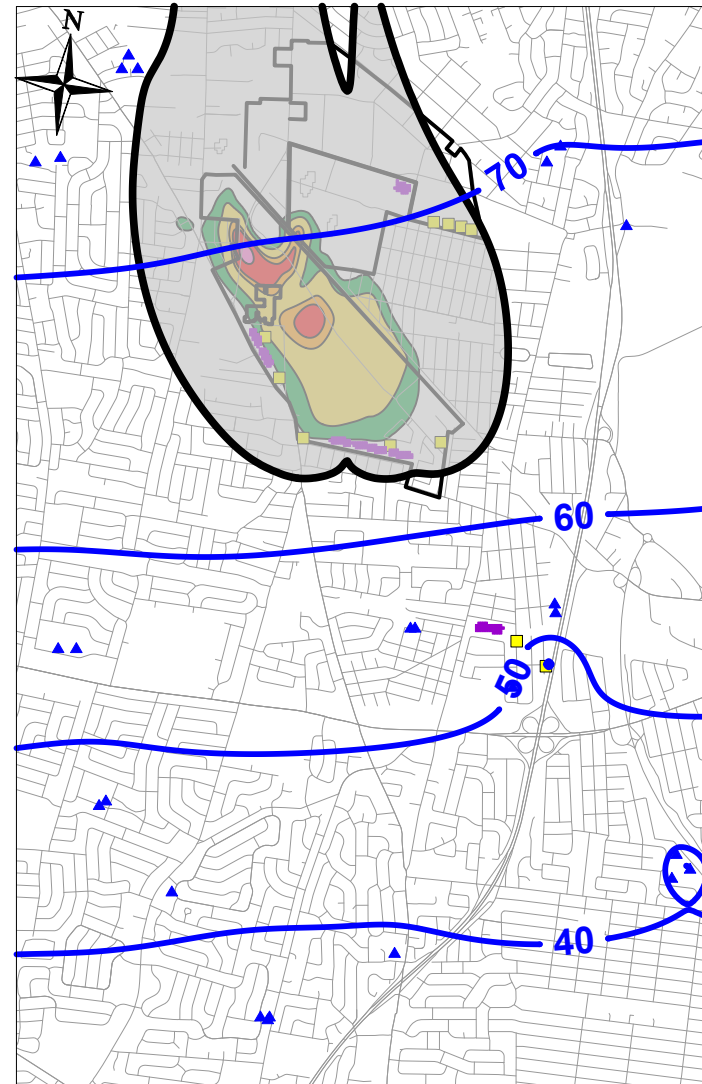

**LAYER 7
(430-505 ft bls)**

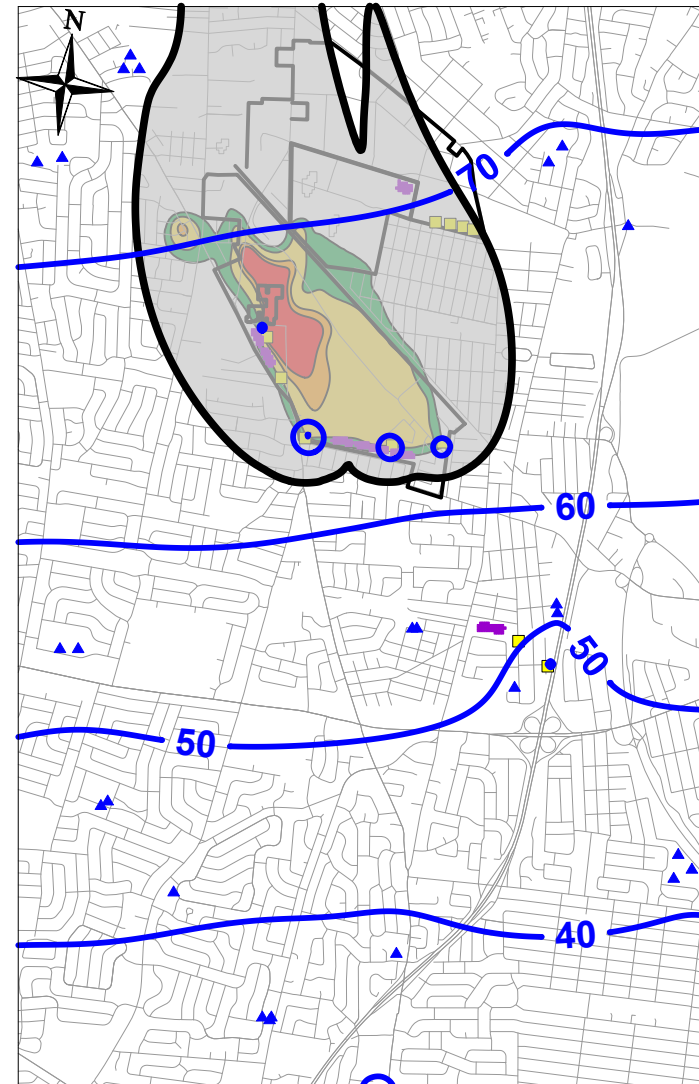

**LAYER 8
(505-580 ft bls)**

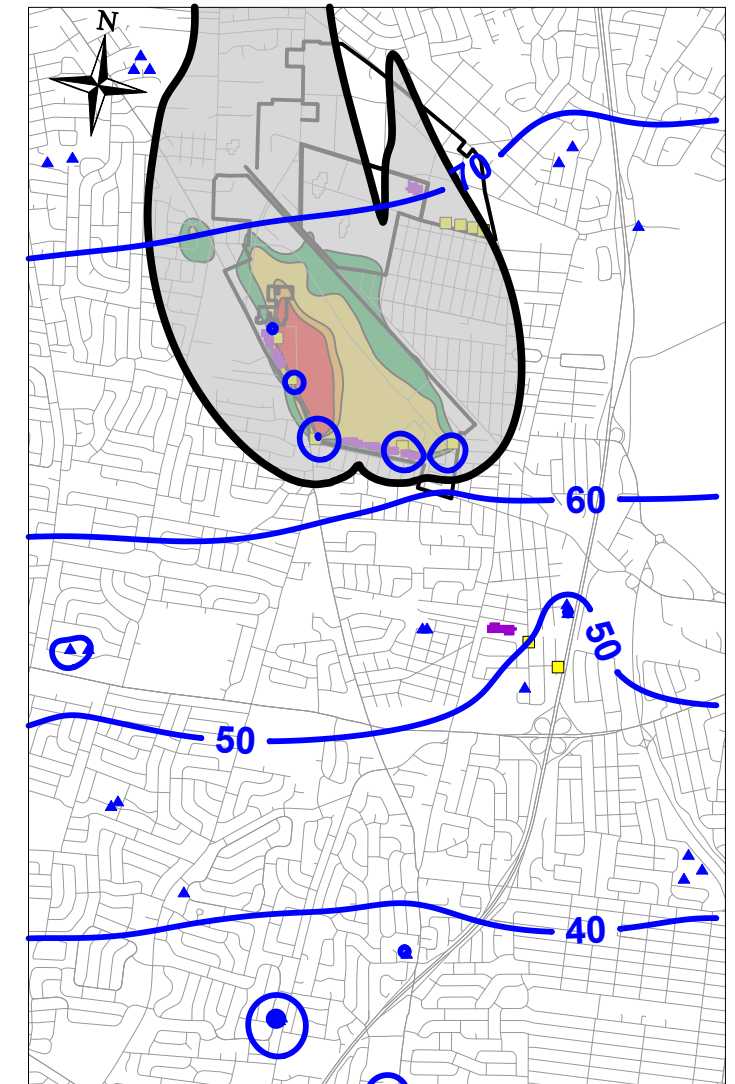

LEGEND

- Site Outline
- 5— Simulated Groundwater Elevation
- Recharge Basin
- ▲ Water Supply Well
- Remediation Well
- Simulated Capture Zone

*Contour intervals are non-uniform for clarity.
 **Recharge basins, water supply wells, and remediation wells are shown on each panel for reference regardless of layer designation.
 ***Pumping wells are also shown regardless of pumping status (wells that are not pumping are shown).

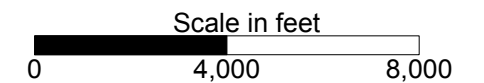
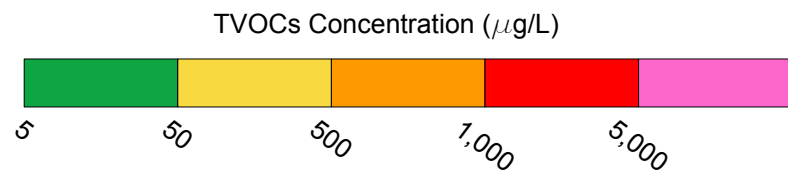

NORTHROP GRUMMAN SYSTEMS CORPORATION
 BETHPAGE, NEW YORK
 GROUNDWATER FLOW AND SOLUTE
 TRANSPORT MODEL UPDATE

MODEL SIMULATED GROUNDWATER
 ELEVATIONS AND GROUNDWATER CAPTURE ZONE
 FOURTH QUARTER 2017 - LAYERS 5 THROUGH 8

ARCADIS Design & Consultancy
 for natural and built assets

FIGURE
17

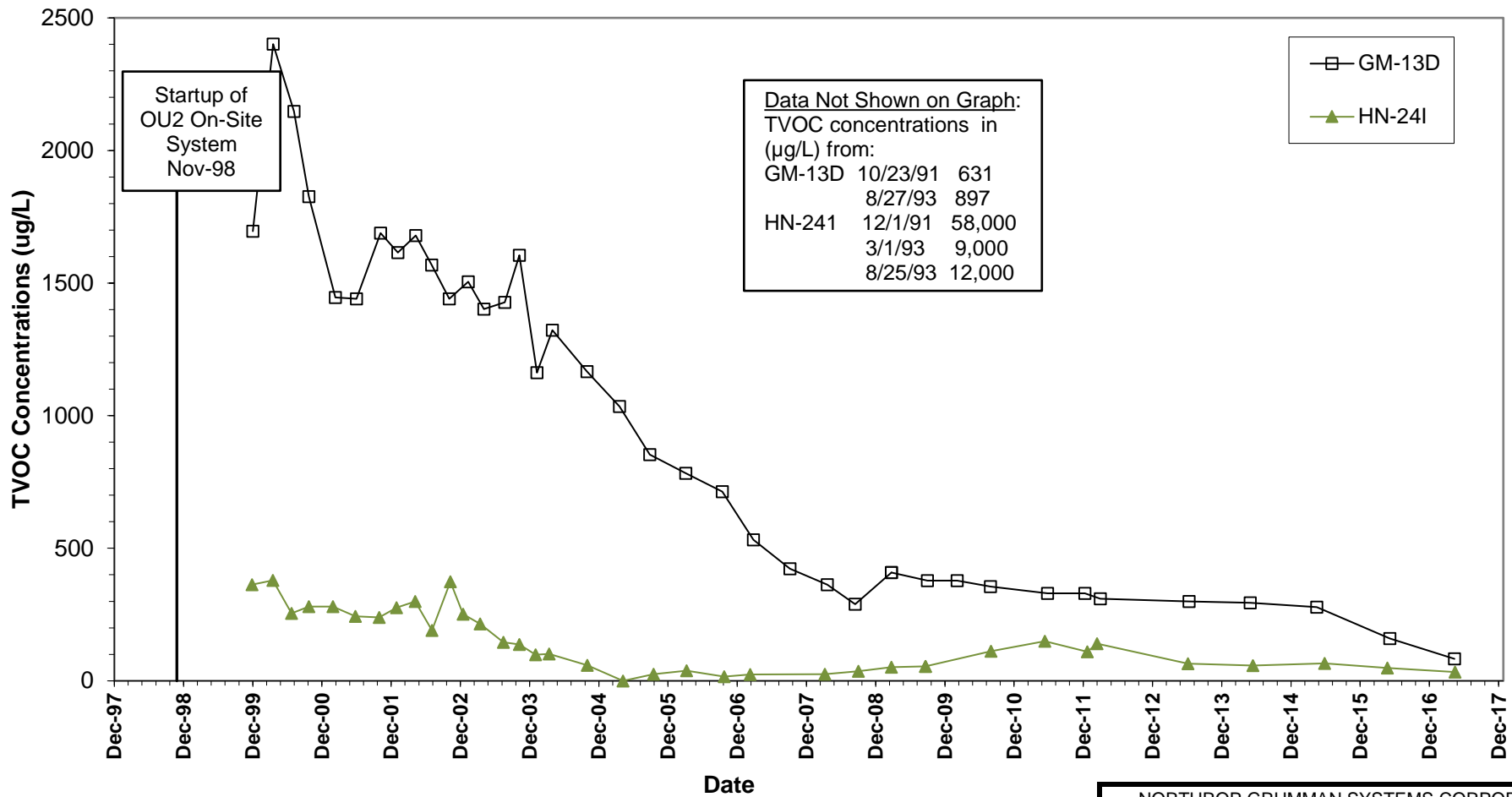

Abbreviation:

TVOC = Total volatile organic compound
 Total VOCs = Sum of VOCs detected
 µg/L = micrograms per liter

NORTHROP GRUMMAN SYSTEMS CORPORATION
 BETHPAGE, NEW YORK
 OPERABLE UNIT 2

**Total Volatile Organic Compound
 Concentrations in On-Site Intermediate
 and Deep Monitoring Wells**



**FIGURE
 18**

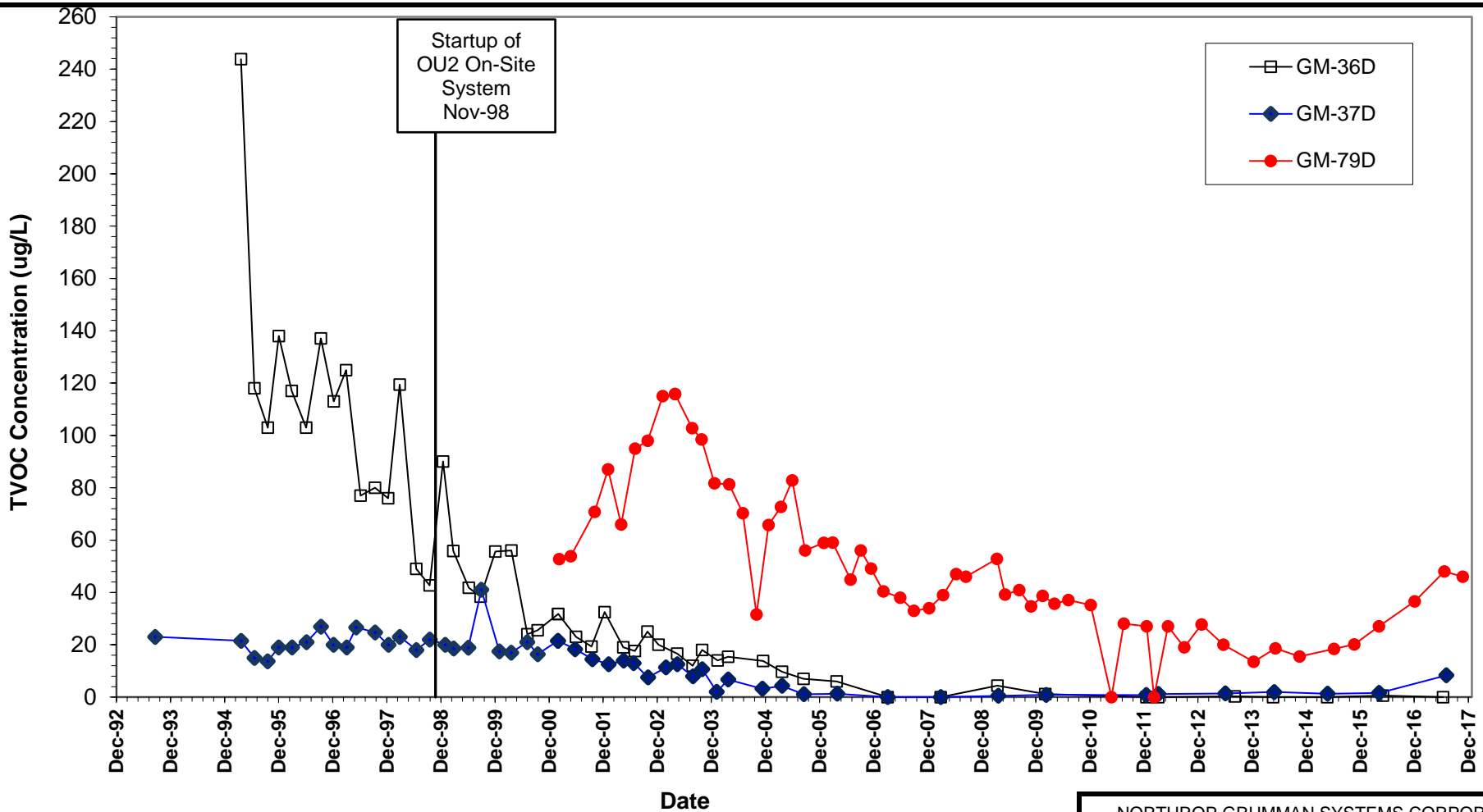

Abbreviation:

TVOC = Total volatile organic compound

Total VOCs = Sum of VOCs detected

µg/L = micrograms per liter

NORTHROP GRUMMAN SYSTEMS CORPORATION BETHPAGE, NEW YORK OPERABLE UNIT 2	
Total Volatile Organic Compound Concentrations in Off-Site Deep Monitoring Wells (Southeast of the Site)	
	<small>Design & Consultancy for natural and built assets</small>
FIGURE 19	

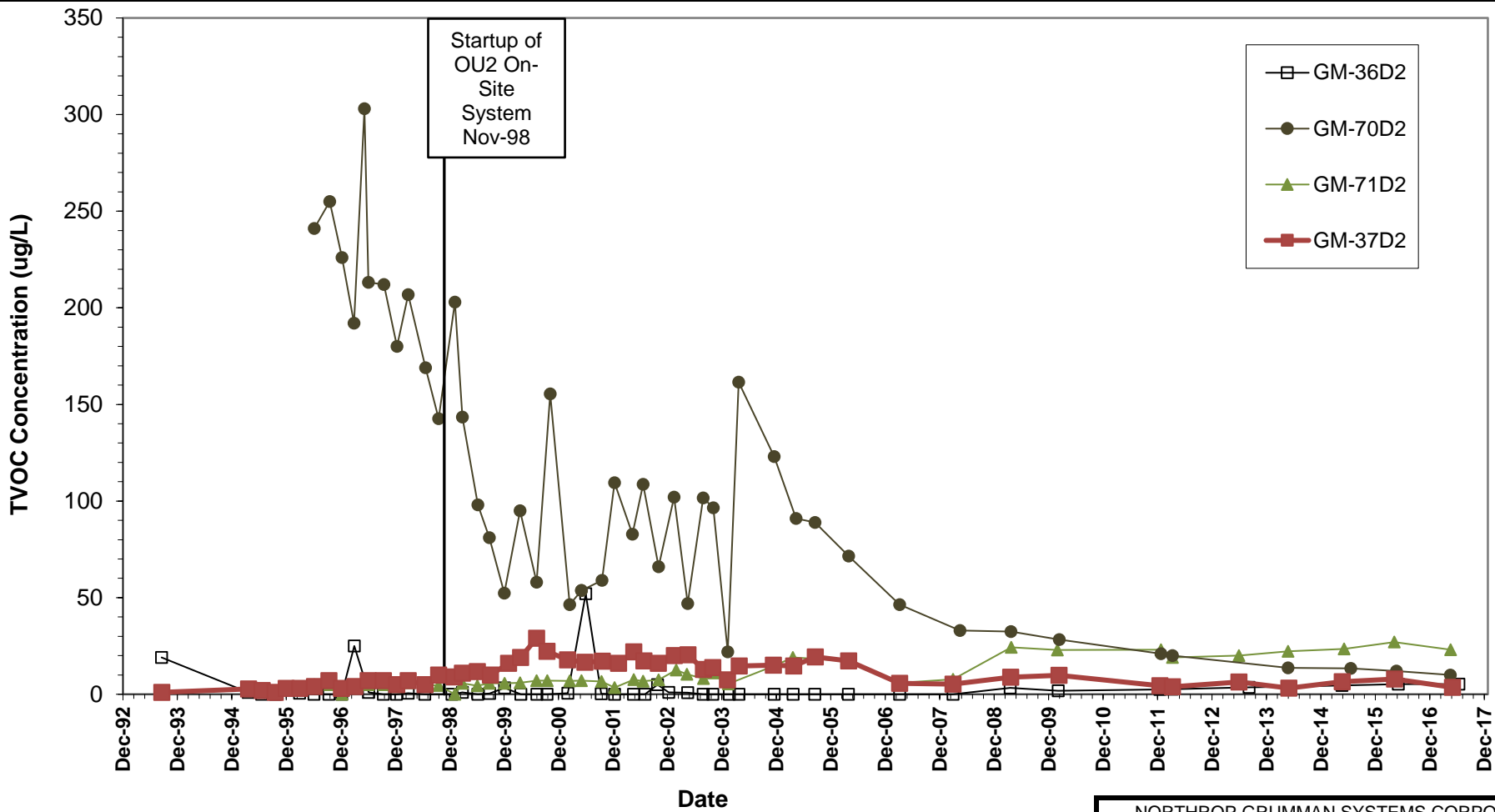

Abbreviation:

TVOC = Total volatile organic compound

Total VOCs = Sum of VOCs detected

µg/L = micrograms per liter

NORTHROP GRUMMAN SYSTEMS CORPORATION
 BETHPAGE, NEW YORK
 OPERABLE UNIT 2

**Total Volatile Organic Compound
 Concentrations in
 Off-Site Deep2 Monitoring Wells
 (Southeast of the Site)**



FIGURE

20

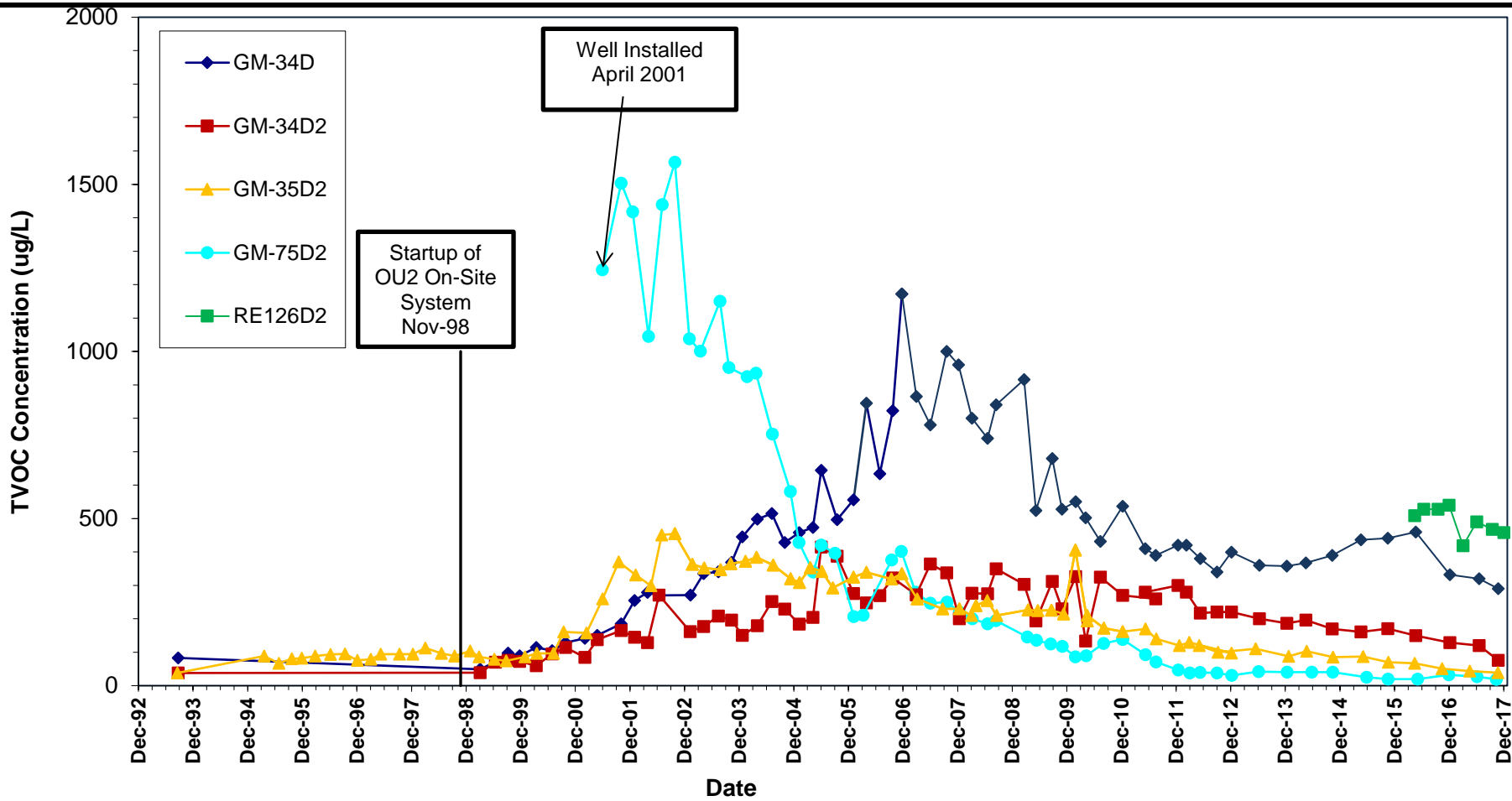

Abbreviation:

TVOC = Total Volatile organic compound

Total VOCs = Sum of VOCs detected

$\mu\text{g/L}$ = micrograms per liter

NORTHROP GRUMMAN SYSTEMS CORPORATION BETHPAGE, NEW YORK OPERABLE UNIT 2	
Total Volatile Organic Compound Concentrations in Off-Site Deep and Deep2 Monitoring Wells (South of the Site)	
	<small>Design & Consultancy for natural and built assets</small>
FIGURE 21	

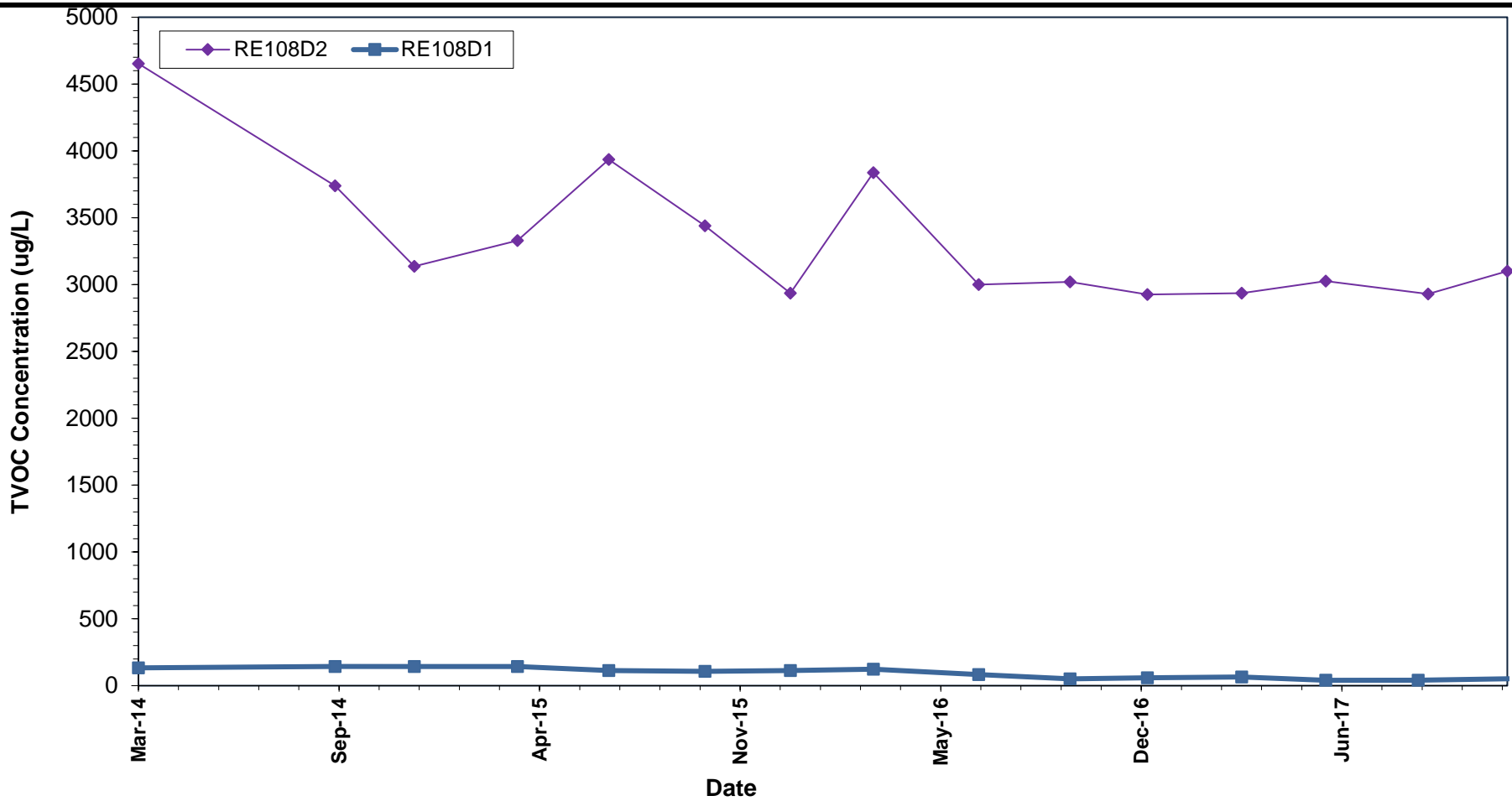

Abbreviation:

TVOC = Total Volatile organic compound
 Total VOCs = Sum of VOCs detected
 µg/L = micrograms per liter

NORTHROP GRUMMAN SYSTEMS CORPORATION BETHPAGE, NEW YORK OPERABLE UNIT 2	
Total Volatile Organic Compound Concentrations in RE108D1 and RE108D2 Wells (South of the Site)	
 ARCADIS	Design & Consultancy for natural and built assets
FIGURE 21A	

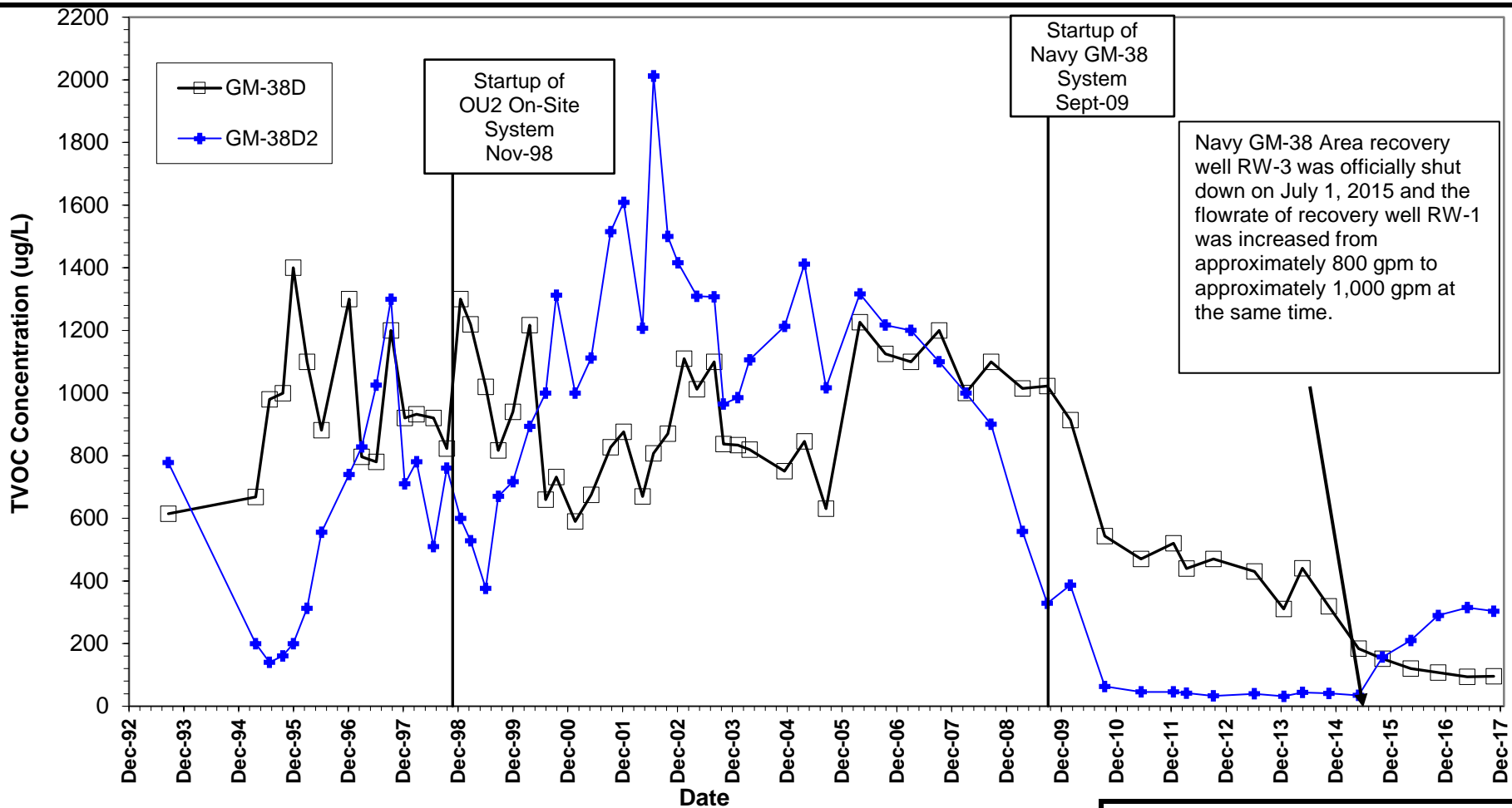

Abbreviation:

TVOC = Total Volatile organic compound

Total VOCs = Sum of VOCs detected

µg/L = micrograms per liter

NORTHROP GRUMMAN SYSTEMS CORPORATION
 BETHPAGE, NEW YORK
 OPERABLE UNIT 2

**Total Volatile Organic Compound
 Concentrations in
 GM-38 Area Deep and Deep2
 Monitoring Wells**



FIGURE

22

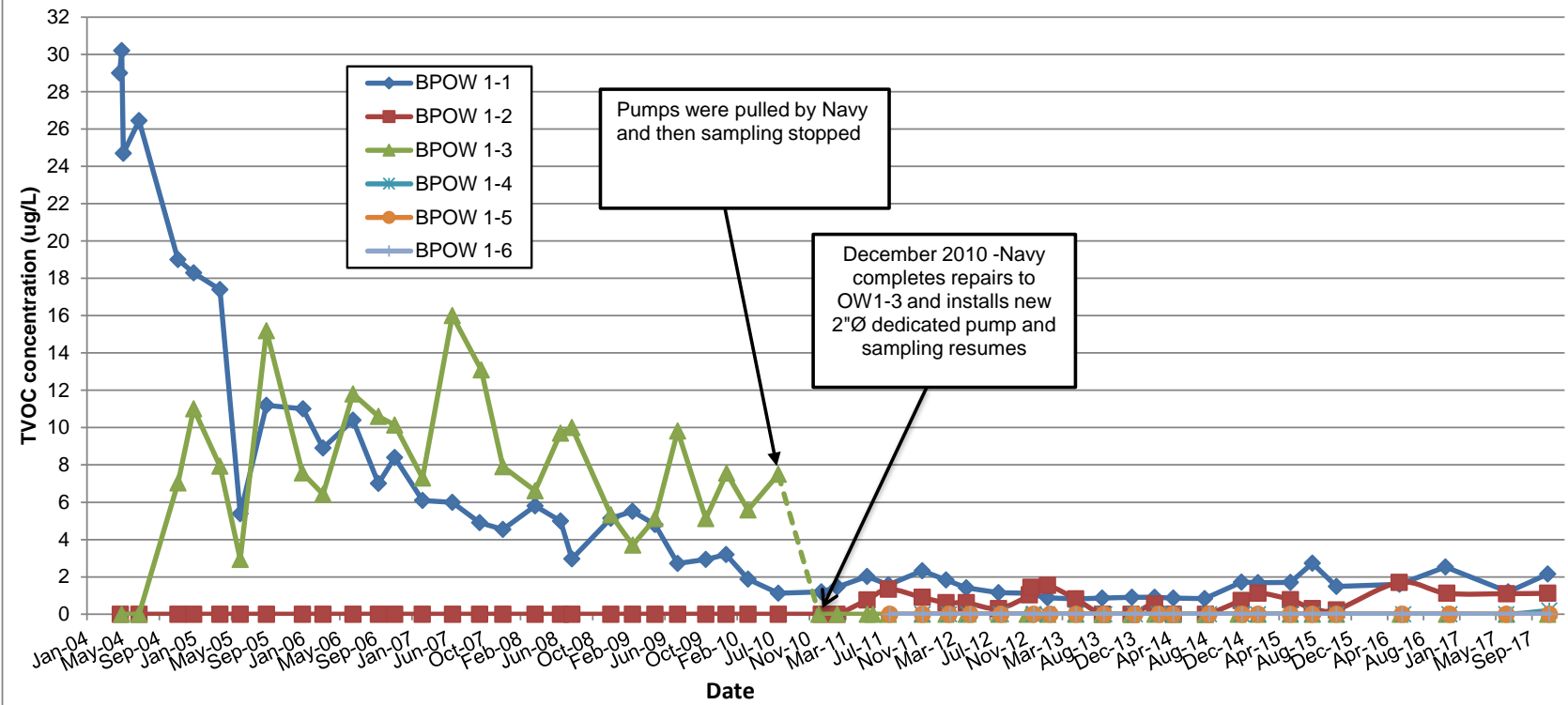

Notes and Abbreviations:

TVOCs: Total Volatile Organic Compounds (sum of 14 site-related VOCs only)
 SFWD: South Farmingdale Water District
 ug/L = micrograms per Liter

NORTHROP GRUMMAN SYSTEMS CORPORATION BETHPAGE, NEW YORK OPERABLE UNIT 2	
TVOC Concentrations in Outpost Wells BPOW1-1, BPOW1-2, BPOW1-3, BPOW1-4, BPOW1-5 and BPOW1-6 (Wells monitor SFWD Well Field 1)	
	Design & Consultancy for natural and built assets
23	

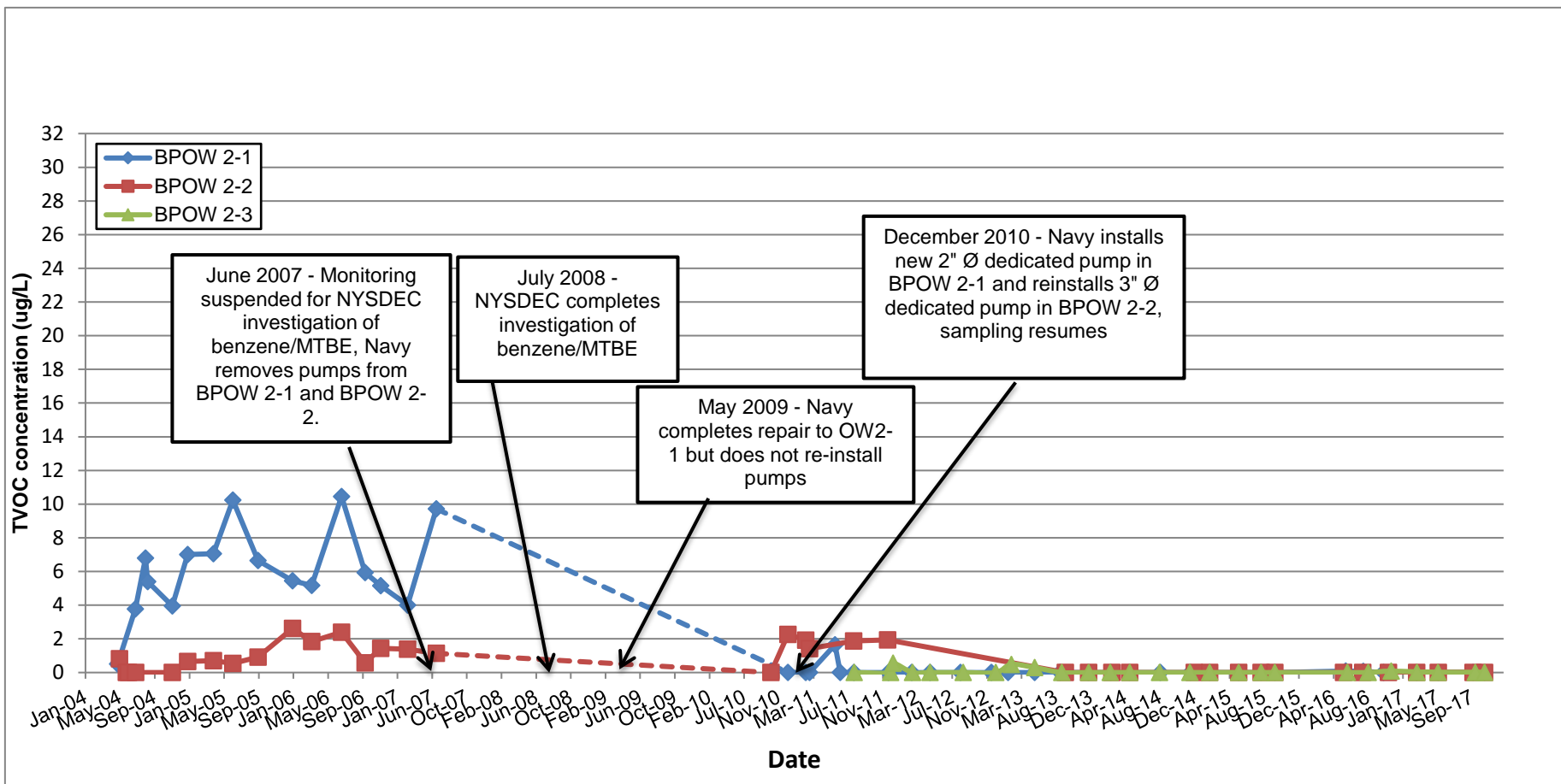

Notes and Abbreviations:

TVOCs: Total Volatile Organic Compounds (sum of 14 site-related VOCs only)
 SFWD: South Farmingdale Water District
 ug/L = micrograms per Liter

NORTHROP GRUMMAN SYSTEMS CORPORATION BETHPAGE, NEW YORK OPERABLE UNIT 2	
TVOC Concentrations in Outpost Wells BPOW2-1, BPOW2-2 and BPOW2-3 (Wells Monitor SFWD Well Field 3)	
	Design & Consultancy for natural and built assets
24	

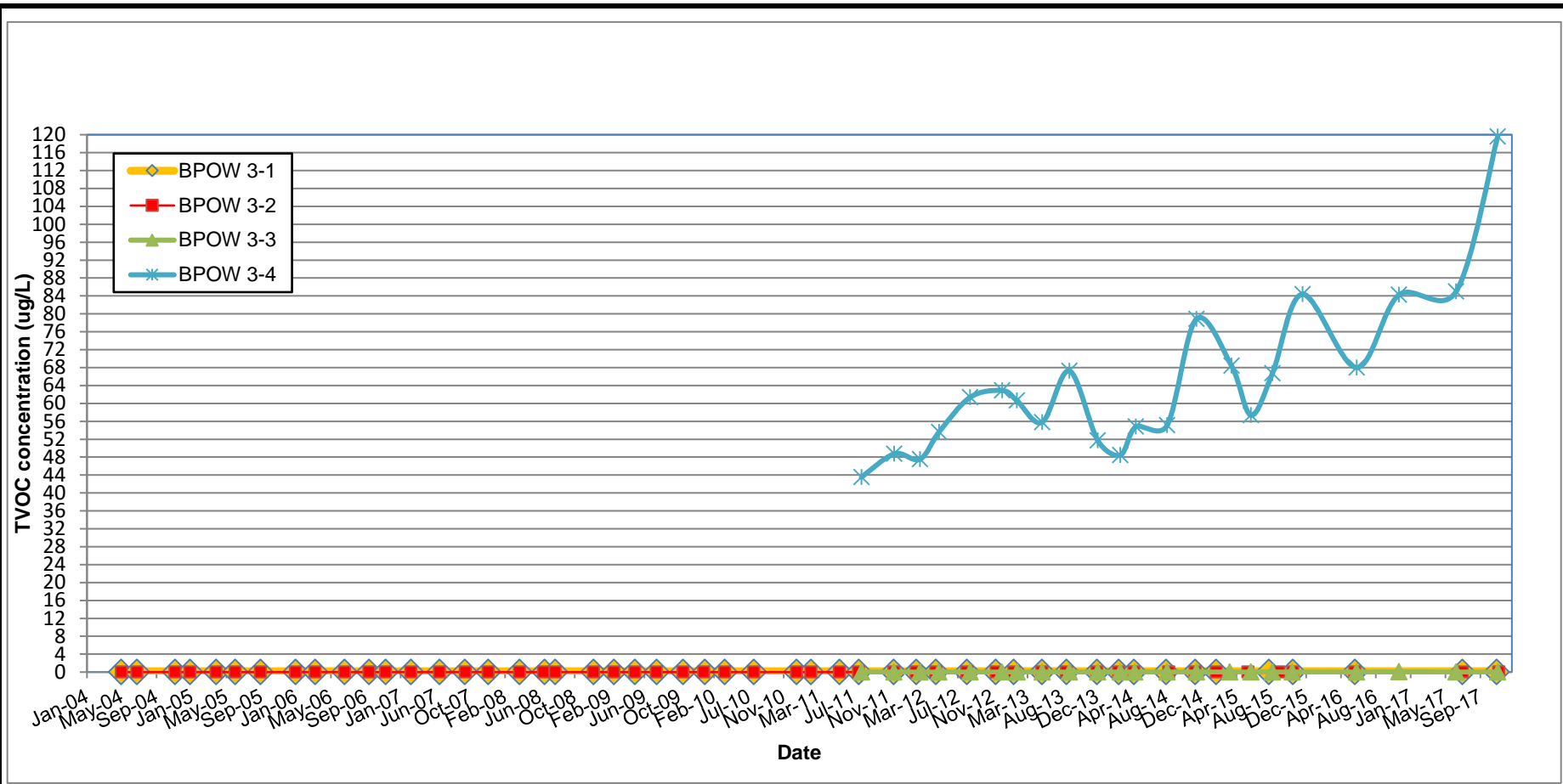

Notes and Abbreviations:

TVOCs for both BPOW 3-1 and BPOW 3-2 are non-detect for the duration of the sample history
 TVOCs: Total Volatile Organic Compounds (sum of 14 site-related VOCs constituents only)
 NYAW: New York American Water
 ug/L = micrograms per Liter

NORTHROP GRUMMAN SYSTEMS CORPORATION BETHPAGE, NEW YORK OPERABLE UNIT 2	
TVOC Concentrations in Outpost Wells BPOW3-1, BPOW3-2, BPOW3-3 and BPOW3-4 (Wells Monitor NYAW Seaman's Neck Well Field)	
 ARCADIS	Design & Consultancy for natural and built assets
25	

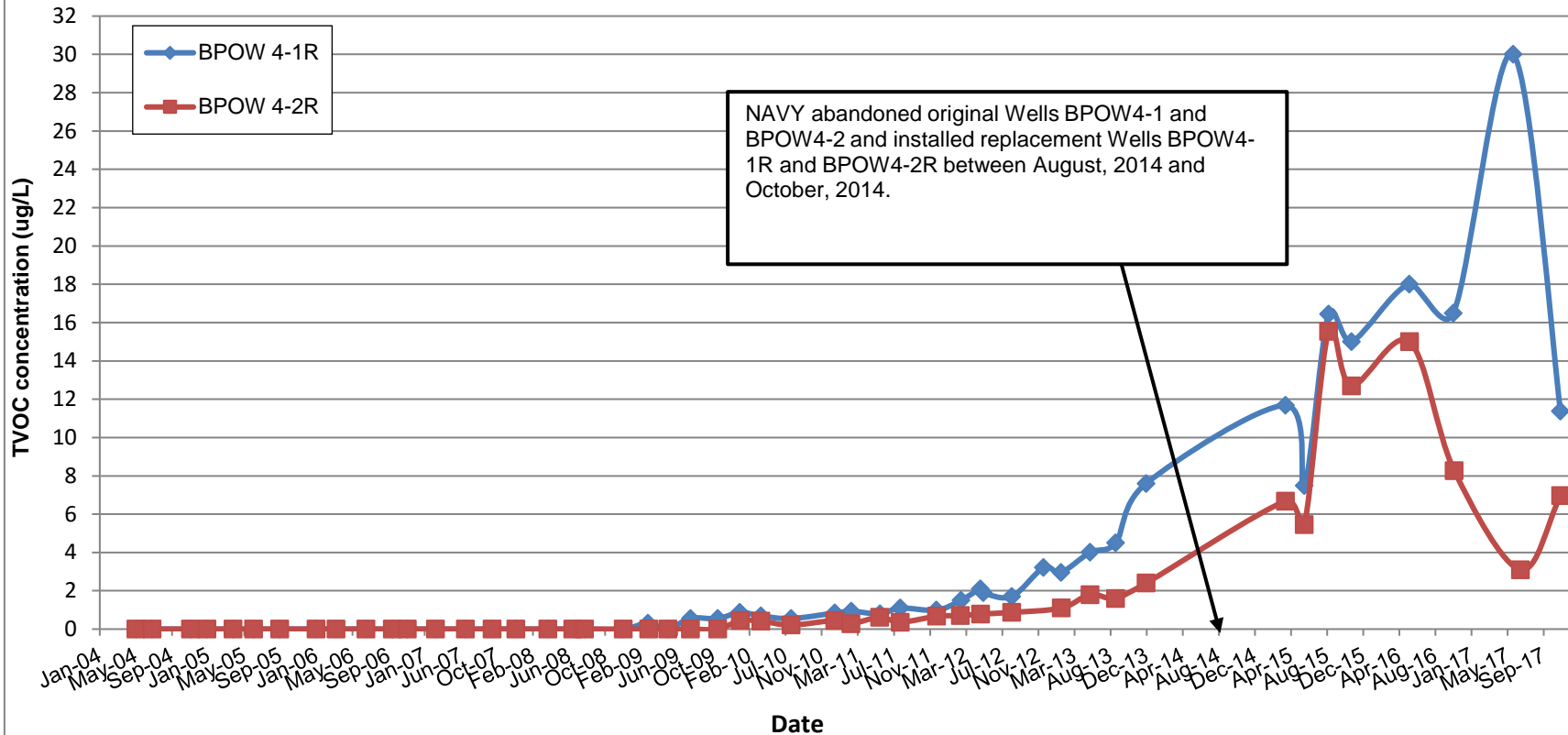

NAVY abandoned original Wells BPOW4-1 and BPOW4-2 and installed replacement Wells BPOW4-1R and BPOW4-2R between August, 2014 and October, 2014.

Notes and Abbreviations:

Samples were not collected from BPOW4-1 and BPOW4-2 in 2014 due to well abandonment/construction activities by NAVY
 TVOCs: Total Volatile Organic Compounds (sum of 14 site-related VOCs only)
 ug/L = micrograms per Liter

NORTHROP GRUMMAN SYSTEMS CORPORATION BETHPAGE, NEW YORK OPERABLE UNIT 2	
TVOC Concentrations in Outpost Wells BPOW4-1R and BPOW4-2R (Wells Monitor Town of Hempstead Levittown Water District Well N-5303)	
	Design & Consultancy for natural and built assets
26	

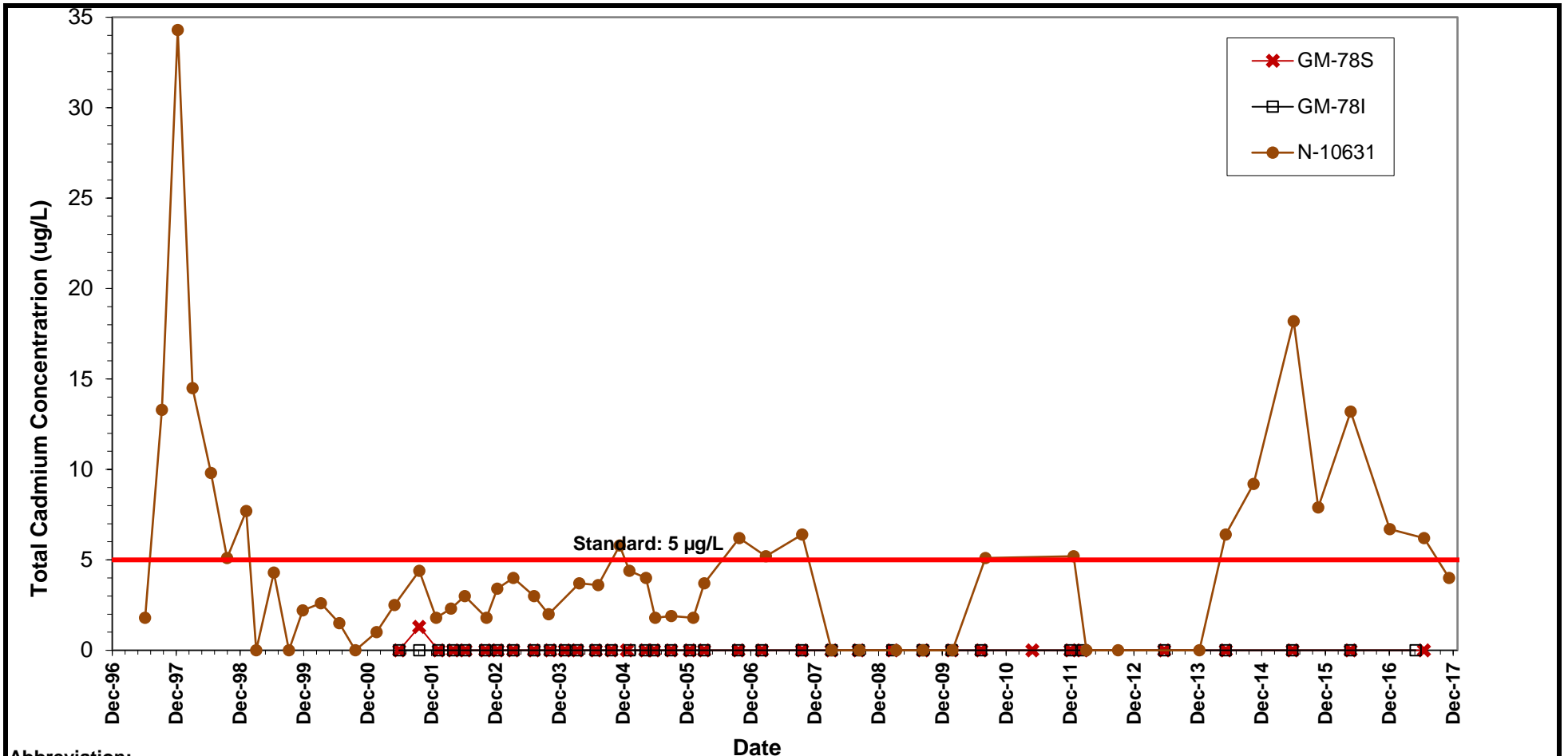

Abbreviation:

µg/L = micrograms per liter

NORTHROP GRUMMAN SYSTEMS CORPORATION BETHPAGE, NEW YORK OPERABLE UNIT 2	
Total Cadmium (not dissolved) Concentrations in Shallow Monitoring Wells Near Former Plant 2	
ARCADIS	<i>Design & Consultancy for natural and built assets</i>
FIGURE 27	

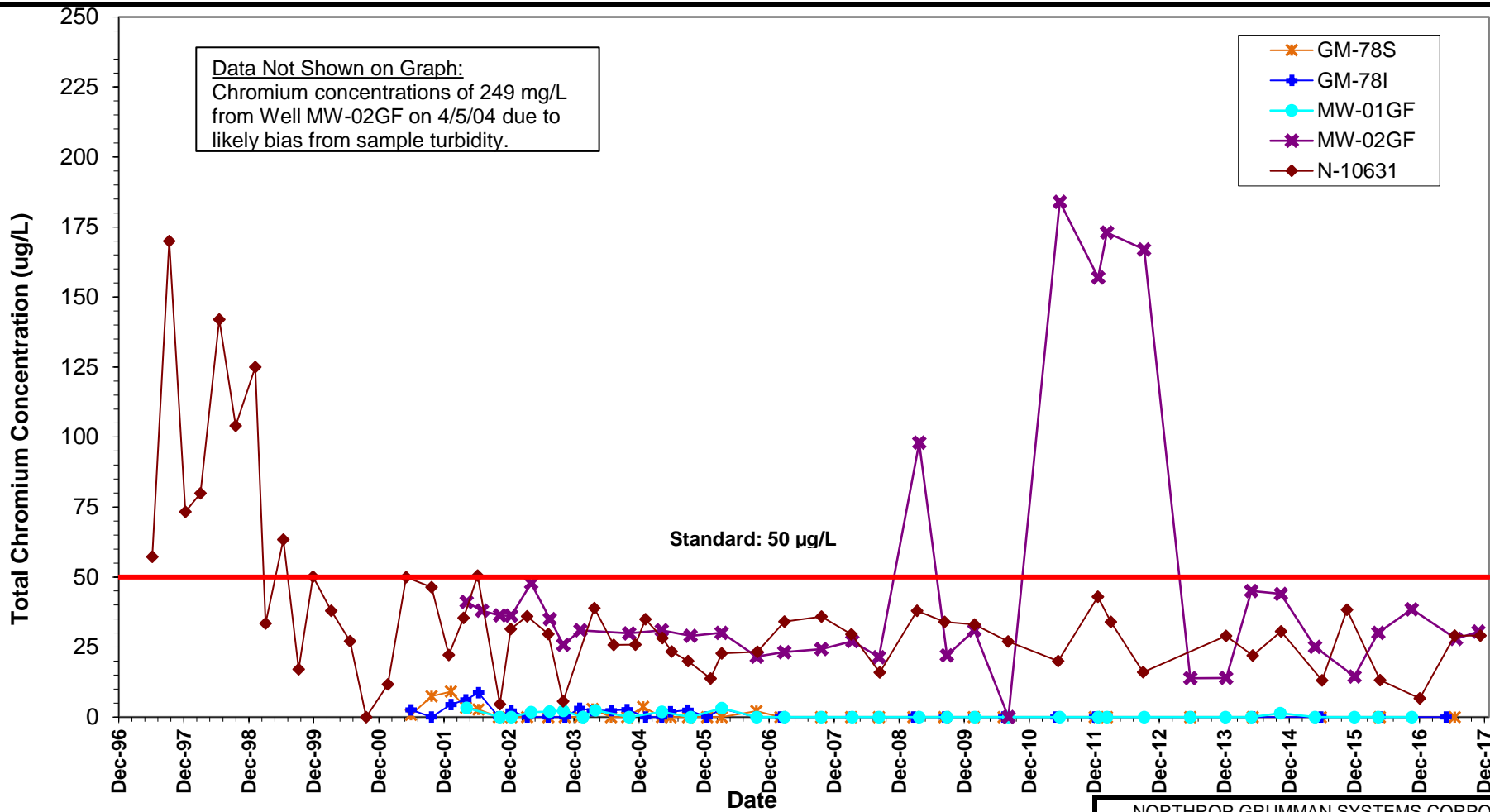

Abbreviation:

µg/L = micrograms per liter

NORTHROP GRUMMAN SYSTEMS CORPORATION
BETHPAGE, NEW YORK
OPERABLE UNIT 2

**Total Chromium Concentrations in
Shallow Monitoring Wells
Near Former Plant 2**



FIGURE

28

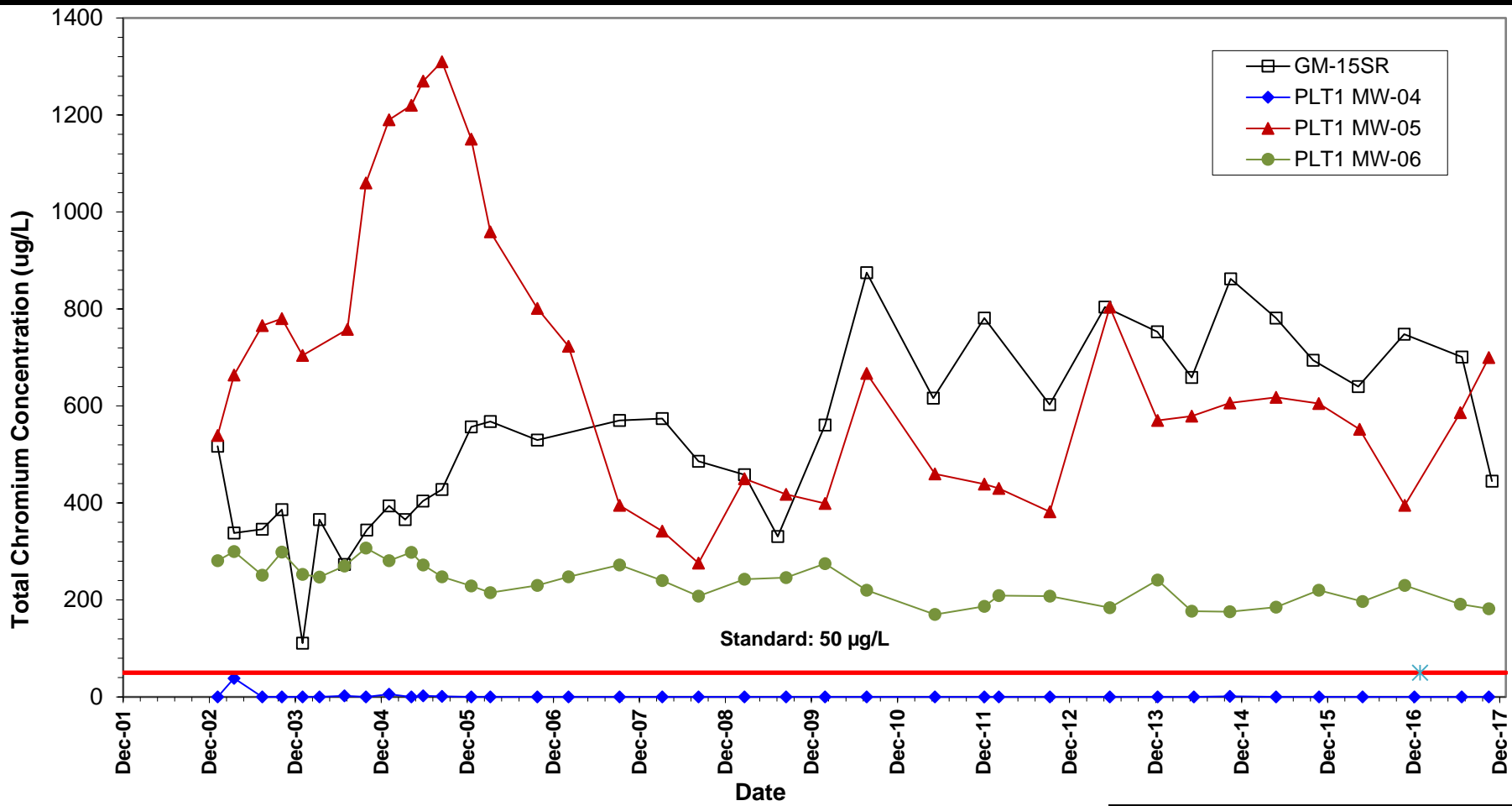

Standard: 50 µg/L

Abbreviation:

µg/L = micrograms per liter

NORTHROP GRUMMAN SYSTEMS CORPORATION BETHPAGE, NEW YORK OPERABLE UNIT 2	
Total Chromium Concentrations in Shallow Monitoring Wells Near Former Plant 1	
	Design & Consultancy for natural and built assets
FIGURE 29	

APPENDIX A

Daily Site Visits



APPENDIX B

Hazardous Waste Manifests



APPENDIX C

Supplemental Monitoring Well GM-21D2 Data Assessment



APPENDIX D

SPDES Discharge Monitoring Reports



APPENDIX E

2017 Groundwater Sampling Logs and Chain of Custody Records



APPENDIX F

Supplemental Groundwater Quality Data



APPENDIX G

Supplemental Modeling Assessment of ONCT Hydraulic Effectiveness



Arcadis of New York, Inc.

Two Huntington Quadrangle

Suite 1S10

Melville, New York 11747

Tel 631 249 7600

Fax 631 249 7610

www.arcadis.com