

NYSDEC



# Evaluation for New OU2 ONCT Treatment Building

## Statement of Work

### **Northrop Grumman Corporation**

925 South Oyster Bay Road

M/S 02/BP15

Bethpage, NY 11714-3582

**March 23, 2023**

## STATEMENT OF WORK:

This document identifies the scope of work and minimum requirements for design. Evaluate two building options to modify our existing onsite containment treatment (ONCT) for groundwater at our Bethpage, NY site. The location of the new treatment building will need to be located on Northrop Grumman owned sites. The most suitable Northrop Grumman sites are where current treatment plants 102 and 109 are located as they are currently connected to the remedial wells and recharge basins. The statement of work will require an evaluation of two existing building sites located in Bethpage, NY and provide a concept building sizing and design, ROM cost estimate in CSI format for building construction for each option, and a proposed construction duration schedule. Estimate and schedule to exclude process equipment and associated installation and influent/effluent pipeline modifications. Final evaluation package to be submitted to Northrop Grumman by May 12th, 2023.

### OPTION 1 - PLANT 102 SITE

Expand existing Plant 102 Treatment building to treat (5) existing wells 1, 3R, 17, 18, & 19.

#### **Background – Plant 102**

The Plant 102 system must remain in operation throughout the building modification with a minimal shut period for the cutover to the new treatment system.

Renovation (to meet current building codes for type of use)

Design approximately 9,000 square foot addition to the existing 2,000 square foot treatment building (minimum 28-foot clear ceiling) that meets building codes within site limitations.

#### **Option 1 Concept only**

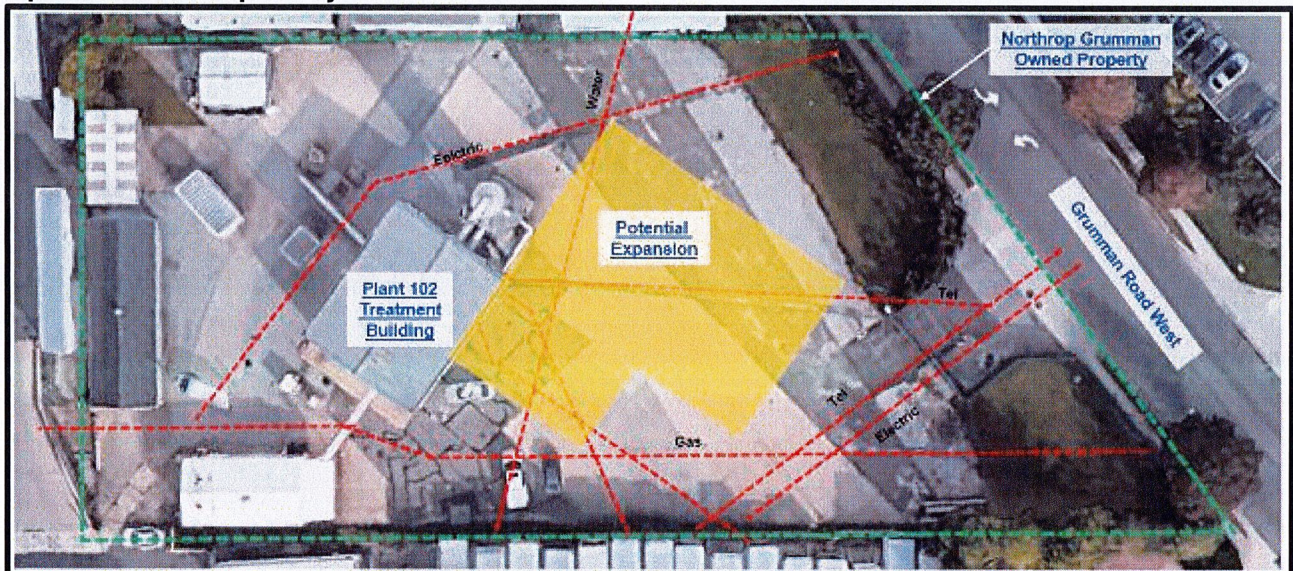

**OPTION 2 – PLANT 109 SITE**

Expand existing Plant 109 Treatment building to treat (5) existing wells 1, 3R, 17, 18, & 19.

**Background - Plant 109**

The Plant 109 system must remain in operation throughout the building modification.

1. Demolition

Demo the existing paved areas necessary for construction and re-route utilities as required.

2. Renovation (to meet current building codes for type of use)

Design approximately a 9,000 square foot addition to existing 13,500 square foot treatment building (minimum 28-foot ceiling) that meets building codes within site limitations.

**Option 2 – Concept only**



## **GROUNDWATER TREATMENT PROJECT BACKGROUND:**

The Grumman Aerospace Corporation (now Northrop Grumman) formerly occupied approximately 638 acres in east-central Nassau County, in the Hamlet of Bethpage, Town of Oyster Bay, New York. Groundwater sampling conducted as part of the Remedial Investigations (RIs) indicates that past chemical storage and/or waste disposal has resulted in impacts to groundwater at the site.

The Operational Unit (OU2) ONCT Groundwater Remediation system was put on-line in 1998 to comply with the New York State Department of Environmental Conservation (NYSDEC) Record of Decision (ROD) to provide on-site containment of volatile organic compound (VOC)-impacted groundwater and preventing, to the extent practicable, the off-site migration of impacted groundwater. The system is expected to operate 24/7 365 days a year.

The OU2 ONCT Groundwater Remediation system consists of:

- Five Remedial Wells (Remedial Wells 1, 3R, 17, 18, and 19) with design pumping rates of 800 gallons per minute (gpm), 700 gpm, 1,000 gpm, 800 gpm and 500 gpm, respectively.
- Two treatment systems (Tower 96 and Tower 102), each consisting of a packed-tower air stripper to remove VOCs from extracted groundwater and regenerable vapor-phase granular activated carbon (RVPGAC) systems, with on-site steam regeneration via on-site boilers, to remove VOCs from the air strippers' off-gas emissions.
  - Tower 96 by design treats 1,500 gpm
  - Tower 102 by design treats 2,300 gpm
- A pressurized discharge main to accept the treated water discharge, which is also available for limited non-potable reuse connects the two treatment systems.
- Two sets of recharge basins (the south recharge basins and the west recharge basins) accept the treated water from the clear wells, which drain by gravity to the basins. A minimum design groundwater model-based discharge rate of 2,231 gallons per minute (gpm) exists for the south recharge basins and any remaining volume is directed to the west recharge basins, as necessary.

### **New Constituents of Concern**

On October 6, 2021, New York State Department of Environmental Conservation (NYSDEC) released water quality guidance values (GVs) for perfluorooctanoic acid (PFOA), perfluorooctane sulfonic acid (PFOS), and 1,4-dioxane. NYSDEC has requested that Northrop Grumman evaluate 1,4-dioxane treatment at the Tower 96 and Tower 102 OU2 ONCT systems.

1,4-Dioxane is less volatile and has a higher boiling point than the VOCs present in the OU2 ONCT treatment systems. Therefore, air stripping and Granular Activated Carbon (GAC) are not effective at removing 1,4-dioxane from water.

As a result, the ONCT system will need to be modified to include Advance Oxidation Process (AOP) technologies. The goal of an AOP treatment system is to produce highly reactive radicals as a source of oxidative power to maximize destruction of chemicals while minimizing formation of by-products. AOP is the most widely used treatment technology for destruction of 1,4-dioxane and is a demonstrated treatment method for chlorinated ethenes. Liquid phase GAC will need to be added as it is effective at quenching AOP byproducts, polishing VOCs and removing PFOA and PFOS from the water.

### **New Treatment Process**

Northrop Grumman has done a desktop study to determine the remediation equipment requirements. This new ONCT groundwater treatment system will require a larger building for this additional equipment. The estimated building size is 9,000 square feet minimum. The system will include multiple tanks which are up to 280-inches high by 144-inches in diameter which will be installed in the treatment building. The new remediation process will use Hydrogen Peroxide 27%. The building code requirement for this chemical tank must be considered in the building design and associated hazard rating.

### **PROJECT GOALS:**

Provide conceptual sketches, design criteria, overall building size, and a ROM cost estimate by CSI division, including estimated engineering costs. Include expected timeframe for construction completion.

The successful bidder must commit to completing this effort by requested date above.

A list of subcontractors to be used on this project must be submitted with the Bid. Northrop Grumman reserves the right to accept or decline any subcontractor submitted.

Within 5 days of contract award, provide and maintain a schedule, which is to be updated with project changes. Schedule is to reflect all project activities.

Portions of this work may be carried out in active treatment areas. The contractor will take all reasonable precautions to protect themselves and NGAS personnel, property, and work in progress. The contractor will be responsible to provide a brief risk analysis and meet with the NGAS project representative, Environmental, Safety, and Health Department (ESH) prior to starting work in these areas to discuss further steps and precautions needed.

***Key Project Information and Requirements:***

- This statement of work outlines requirements for the project which are in addition to NGAS Terms and Conditions. All sections, including Project Goals and Schedule Requirements are applicable as project requirements.
- The project is to be built in compliance with all local building and safety codes and in accordance with the current versions of NGAS Design Requirements and NGAS Design Requirements Sections.
- Safety Data Sheets (SDS) for all chemical materials must be submitted to the project representative on NGAS required ESH forms no later than 2 weeks prior to bringing any material on site.
- Provide proper signage at all construction entrances listing Contractor Name, Contacts and phone numbers, safety precautions and proper PPE etc.
- Conduct progress meetings, including taking and publishing meeting minutes.
- Provide a two-week look-ahead report of planned activities. The report is to be updated and delivered to the NGAS project representative weekly.
- Keep logs of (1) Request for Information (RFI), (2) Submittals, (3) Change Order Requests (COR), and (4) Contract Change Notices (CCN)
- The successful bidder will assign a Project Manager.
- Where this specification is less stringent than or in conflict with the governing construction code, the code shall take precedence.

**PROJECT REQUIREMENTS*****1.0 General***

The Contractor shall be responsible for providing technical services to develop conceptual design and associated estimates to enable NGAS to choose a viable option which will be planned for start of implementation in 2023.

***2.0 Codes and Standards***

The project shall be designed in accordance with the latest editions of building codes including state and local building and safety codes currently in effect.

***3.0 Site Access / Egress***

General site access/egress

Working hours for field visits are from 7:00AM EST to 4:30P EST. All disruptive work, if necessary, shall be accomplished during off hours. The contractor is advised that NGAS

works an alternating Friday off program that will provide additional daylight "off hours". All after hour work is to be coordinated with ESH Project Lead.

Badging:

Coordinate with ESH Project Lead for badging process. Most sites require the coordination and issuing of badges prior to work. Additional escorting may be required as well (see Northrop Grumman Security Procedures, section 7 of this document).

#### **4.0 Project Administration**

The Contractor shall meet with NGAS to establish team responsibilities, methods of approval, project procedures and schedule requirements.

The contractor, unless directed otherwise is to bill the project on the 10th of each month for the work completed over the last month.

#### **5.0 Coordination**

The Contractor shall verify all information provided by Northrop Grumman via physical inspection.

The Contractor shall conduct weekly project coordination meetings at a minimum.

The Contractor shall be responsible for documenting all project coordination meetings. Minutes of the meetings shall reflect the meeting agenda, discussions and action items including due dates.

#### **6.0 Change Orders**

All change orders will be submitted to Contracts/Procurement and ESH. ESH will review all change orders to determine suitability and make a change order account determination. ESH will be responsible for forwarding a change notice through Procurement to become a part of the contract as final acceptance of the Change Order approval.

### **CONTRACTOR RESPONSIBILITY (DESIGN)**

#### **7.0 General**

The A&E shall be responsible for providing technical services to develop and execute Conceptual drawings, associated design criteria, estimate and schedule duration requirements for implementation.

#### **8.0 Field Investigation**

The A&E shall provide complete field investigations as necessary (e.g., examining and verifying existing conditions) to verify NGAS provided information.

## **9.0 Subcontractor Coordination**

The Contractor shall perform all services, using only State licensed sub-contractors.

NGAS shall approve the Contractor's selections of sub-contractors prior to commencement of work. Any sub-contractors found to not have proper certifications or trainings related to high-risk tasks (e.g., high voltage, confined space, asbestos/lead abatement, silica tasks, cranes, etc.) will not be allowed to perform services until regulatory requirements are full filled. If sub-contractor cannot obtain said requirements in a timely manner to execute work another sub-contractor must be chosen.

## **10.0 Safety**

If contractors bring explosives/lasers/or radioactive materials as part of equipment or machinery used for project, ESH must be notified prior to these materials arriving on-site. If project requires removal or relocation of items or equipment containing these special materials ESH must be notified.

These documents are provided at the time of contract award and the lead Contractor representative shall keep an organized binder(s) with safety related documentation and shall include the job hazard analysis, weekly safety meetings, weekly safety inspections, equipment inspections, incident reports, training documentation and other safety related information available upon request.

## **11.0 Selection Criteria**

The Proposals will be evaluated based on each firm's qualifications, approach, methodology and relevant experience with similar projects. NGAS will further evaluate the firms based on their performance history, proposed team members, knowledge of the various issues, technical capabilities, proposed fees and overall responsiveness to this RFP. The following factors are important for further consideration and evaluation which shall not be construed as a comprehensive list:

1. Demonstrated Capability / Past Performance
2. Project Approach
3. Project Organization / Management
4. Personnel Experience and Qualifications / Staffing capabilities
5. Schedule Compliance
6. Overall, Fee / Projected total cost of services.



## **GENERAL DESIGN REQUIREMENTS**

### ***1.0 General***

The following specification outline is intended to provide the minimum parameters required to develop a cost estimate for the building options. The outline is also provided as a design baseline that can be used by Architectural & Engineering firm to provide preliminary design concepts. Conceptual process line requirements provided.

### ***2.0 Treatment Building Configuration***

- A. Floor load capacity: TBD based on equipment load.
- B. Ceiling height: 28 feet minimum clear height
- C. ADA Compliant
- D. Exterior parking
  - 1. Illuminated
  - 2. Include ADA compliant parking
  - 3. Low maintenance exterior landscaping
  - 4. Fully striped
- E. Sprinkler and fire alarm systems throughout.
- F. General finishes
  - 1. Exterior – Painted metal panel or Brick or combination thereof
  - 2. Exterior windows to provide natural light
- G. Flooring
  - 1. All process room floor to be polished concrete
- H. Wall Construction
  - 1. Metal Panel and or Block construction as required by code hazard.
- I. Wall finishes - Interior
  - 1. Painted concrete block or pre- finished metal panel
- J. Mechanical
  - 1. Provide an operationally cost effective, a complete year-round automatic Heating System with capacity sized to maintain minimum 60 degrees.
- K. Electrical
  - 1. All electrical work shall be completed in accordance with the National Electric Code (NEC)
  - 2. Power Distribution TBD Kva Transformer based on equipment
  - 3. Motor Control Center for electrical distribution panel for process equipment
  - 4. Lighting
    - a. All areas shall have a code minimum foot candles along complete path of egress when normal lighting is off. The source shall be derived from emergency battery packs.
    - b. Lighting fixtures shall be LED with average foot-candle level of approximately 45 for all areas.

- c. Furnish emergency exit lighting in all areas as required by National, State, and Local codes. High efficiency LED exit lights shall be utilized.
- d. Exterior lighting shall be LED in parking areas and on building walls.
- e. Lighting Control - all areas to have lighting controllers /contactor for full scheduling control.
- f. Provide emergency power to all surveillance systems (including necessary lighting), access control devices, alarms, minimum of one elevator per building, and all national, state, and local codes.

#### M. Special Requirements

- 1. Building signage to include address (numbers only) on exterior. Door signage including room number.
- 2. Columns to be labeled.
- 3. All door locksets to be lever type and be 'Best core' compatible with removable core. All cores to be provided by NGAS.
- 4. Security Control Center
  - a. In addition to monitoring the perimeter intrusion alarms, card access system, CCTV, arrangements should be made that all water flow/sprinkler, smoke, and heat detecting alarms be tied into our existing Security Control Center.

**ATTACHMENT 1**

**OU2 ON SITE CONTAINMENT SYSTEM**

## New OU2 ONCT Treatment Building Pipeline Requirement – One Treatment Plant

Assume wells 1, 3R, 17, 18, 19 are treated in one new building at Plant 102r Plant 109 additions

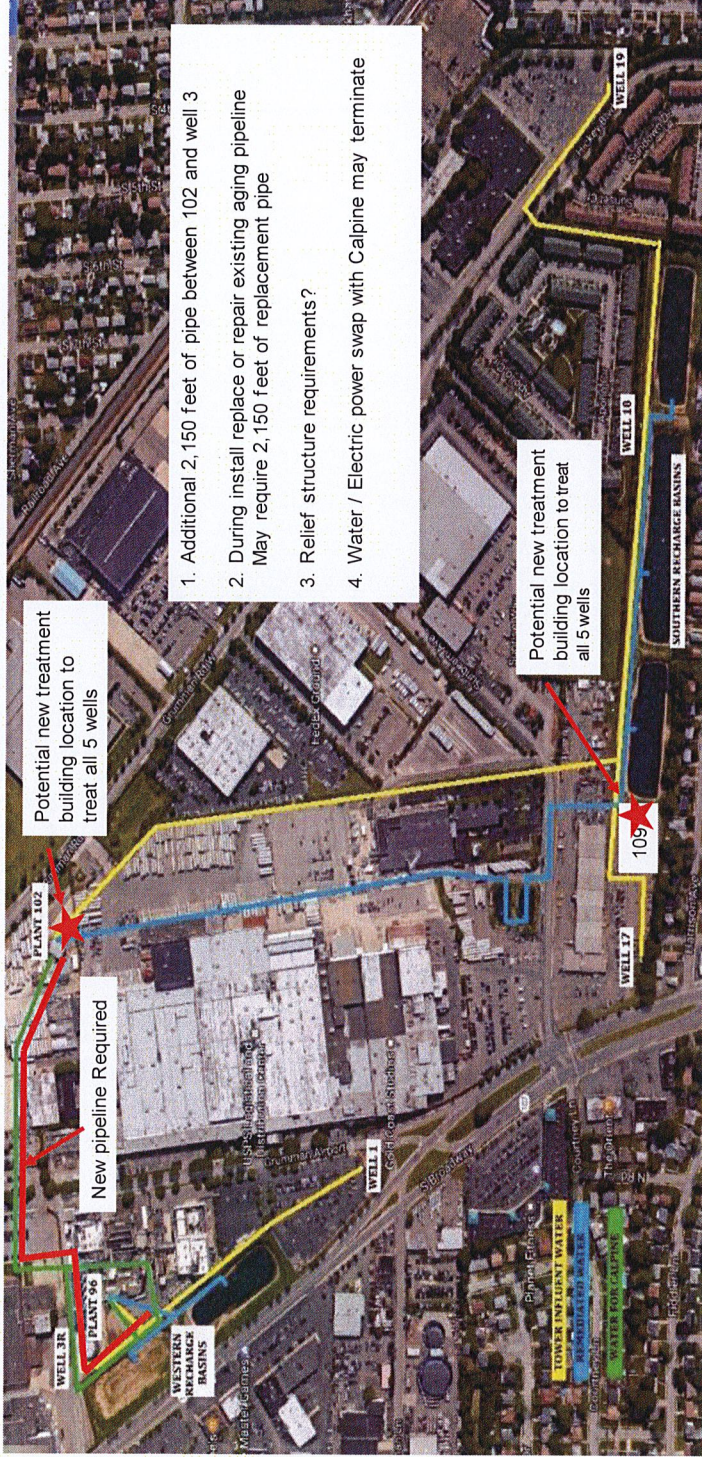

**ATTACHMENT 2**

**CONCEPTUAL NEW PROCESS FLOW**

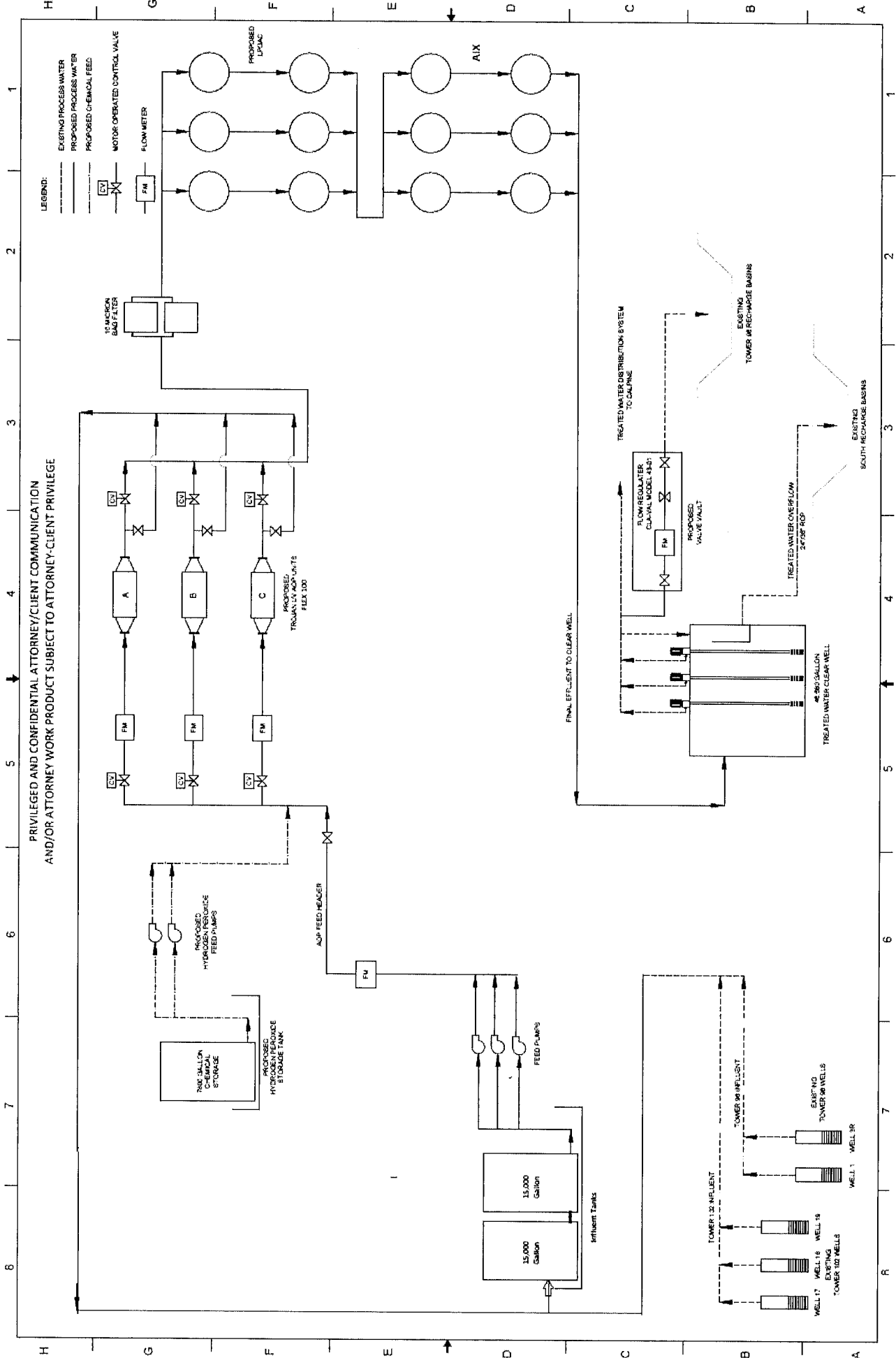

PRIVILEGED AND CONFIDENTIAL ATTORNEY/CLIENT COMMUNICATION  
AND/OR ATTORNEY WORK PRODUCT SUBJECT TO ATTORNEY-CLIENT PRIVILEGE

## ATTACHMENT 3

### **CONCEPTUAL** NEW PROCESS EQUIPMENT

- 3.1 Influent Tank - Wagner
- 3.2 Hydrogen Peroxide Tank – Peabody
- 3.3 AOP – TrojanUV Flex 100
- 3.4 Bag Filters – Commercial Filtration Supply
- 3.5 LGAC Tanks – TetraSolv Filtration
- 3.6 AIX Tanks - AdEdge

**ATTACHMENT 3.1**

**CONCEPTUAL NEW PROCESS EQUIPMENT**

**INFLUENT TANKS - WAGNER**



REV	DESCRIPTION	DATE
3	ROTATED LUGS & N10 PER CUSTOMER MARK UP.	12/20/21
2	CHANGED DOWN PIPE DESIGN.	11/11/21
1	DELETED N1, N9 & N16. ADDED DOWNPIPE TO N13 & BLIND FLANGE TO N5. CHNG N6 TO 3" F.N. & RELOCATED FITTINGS PER CUSTOMER MARK UP.	10/21/21
REV	REVISION	DATE

- PROJECT NOTES**
- WHITE (WJ-480) EXTERIOR GEL COAT WITH U.V. INHIBITOR REQUIRED.
  - SUBPART 3A DESIGN BY RULES (NO STAMP, PAPERWORK OR TESTING WILL BE PROVIDED)
  - NON-SKID DOME TOP SURFACE REQUIRED.
  - (1) SET OF PLASTIC FLANGE PROTECTORS REQUIRED FOR SHIPPING.
  - REQUIRED TESTING ON TANK:
    - VISUAL INSPECTION IN CONFORMANCE WITH ASTM C-582, TABLE 5.
    - BARCOL HARDNESS PER ASTM D-2583.
    - ACETONE SENSITIVITY PER REFERENCED TANK DESIGN.

OWNER	ARCADIS
P.O. No.	30081583.TSF4
EQUIP. No.	T-200
SERVICE	WASTEWATER (W) TRACE AMOUNTS, LESS THAN 10 ppm, OF VARIOUS CHEMICALS.)
<b>DESIGN DATA</b>	
DESIGN STANDARD	ASME RTP-1 (SEE NOTE 2)
MAX. PRESSURE	ATMOSPHERIC
VACUUM	NONE
UPLIFT PRESSURE	NONE
MAX. TEMP. (F)	100°
SPECIFIC GRAVITY	1.2 MAX.
SEISMIC CODE	ASCE 7-16 (SITE CLASS-D)
SEISMIC DESIGN	RISK CATEGORY=II
WIND LOAD	SDS=0.258, SD1=0.088
APPROX. EMPTY WEIGHT (LBS)	121 MPH
NOM. CAPACITY (GALS)	5,200
CORROSION BARRIER CATALYST	30 P.P.S.F
CORROSION BARRIER VEIL	COMIEKP
STRUCTURAL CATALYST	SINGLE NEAUS
INSULATION (TH.)	DERAKANE SIGNIA 411
INSULATION CASE RESIN	NONE
EXTERIOR VEIL	SINGLE GLASS
COLOR	WHITE (WJ-480)

<b>LAMINATE SEQUENCE</b>	<b>THICKNESS</b>
V = 1 LAYER VEIL	.010"
M = 1 1/2 OZ/FT SQ. CHOPPED STRAND	.043"
FM = FIBERMAT 1524	.076"
R = 24 OZ/YD. SQ. WOVEN ROVING	.033"
CP = CHOPPED STRAND ROVING	
HW = FILAMENT WINDING	.056"
CH = CHOP-HOOP WINDING	.039"
SW = STRAIGHT WIND	.028"
U = 15 1/2 OZ/FT. SQ. UNIDIRECTIONAL	.022"
DOME TOP: .333" NOM. TH.	
V CP(100) CP(050) R CP(130) V	
INTERIOR: 3M V EXTERIOR: 4M V	
SIDEWALL: .318" NOM. TH. TAPER TO .290" NOM. TH.	
V CP(100) 2(CP(050) R) CP(134) V	
FLAT BOTTOM: .428" NOM. TH.	
V CP(100) 2(CP(050) R) CP(134) V	
KNUCKLE THICKNESS: .738" NOM. TH.	
FLAT BOTTOM + 3(R CP(073))	
HOLD DOWN LUG WALL THICKNESS: .705" NOM. TH.	
CP(219) + 65W + SIDEWALL	

REVISED PRINT  
DATE: 12/20/21

RELEASED FOR FABRICATION  
DATE: 11-11-21

- GENERAL NOTES**
- ALL INFORMATION SHOWN HEREON IS COPY RIGHT PROTECTED. REPRODUCTION OF ANY PORTION OF THE DRAWINGS IS A VIOLATION OF COPYRIGHT LAWS.
  - ANY INFORMATION FROM, ADDITION TO, SUBSTITUTION FOR, OR MODIFICATIONS TO THE INFORMATION SHOWN ON THESE DRAWINGS SHALL BE SUBMITTED TO THE FABRICATOR'S ENGINEER OF RECORD FOR REVIEW AND APPROVAL PRIOR TO BEGINNING ANY CHANGE OR SUBSTITUTION.
  - THE DRAWINGS AND SPECIFICATIONS REPRESENT THE FINISHED DESIGN. RESPONSIBILITY FOR THE MEANS AND METHODS OF COMPLETING THE INSTALLATION IS BY OTHERS.
  - ALL DIMENSIONS ARE IN INCHES.
  - ALL FLANGE BOLT HOLES TO STRADDLE RADIAL CENTERLINES.
  - THESE DRAWINGS ARE NOT TO BE SCALED FOR DETERMINATION OF QUANTITIES.
  - ALL DIMENSIONS ARE TO FACE UNLESS OTHERWISE NOTED.
  - PLEASE READ BELDING TANK TECHNOLOGIES HANDLING INSTRUCTIONS CAREFULLY. FAILURE TO COMPLY WITH INSTRUCTIONS MAY DAMAGE TANK & VOID WARRANTY. PRIOR TO INITIATING INSTALLATION, VERIFICATION OF ALL EXISTING CONDITIONS AND FIELD REQUIREMENTS IS BY OTHERS.
  - APPLICABLE FEDERAL, OSHA, STATE AND LOCAL BUILDING CODES AND ORDINANCES IS BY OTHERS. IN THE EVENT OF A DISCREPANCY BETWEEN THE CODES, THE MORE STRINGENT SHOULD BE FOLLOWED.
  - PROVIDE ALL MEASURES NECESSARY FOR THE PROTECTION OF THE WORKERS AND OTHER PERSONS DURING INSTALLATION.
  - THE FOUNDATION DESIGN AND CONSTRUCTION SHALL BE THE RESPONSIBILITY OF THE OTHERS. BELDING TANK AND ITS ASSIGNS SHALL NOT BE RESPONSIBLE FOR THE DESIGN, CONSTRUCTION, AND ADEQUACY OF THE FOUNDATION. THE OWNER SHALL INDUSTRY AND HOLD HARMLESS BELDING TANK AND ITS ASSIGNS FOR ANY ACTION ARISING FROM OR ALLEGING TO ARISE FROM THE DESIGN AND/OR CONSTRUCTION OF THIS TANK.
  - DO NOT COUPE ANCHOR BOLTS IN THE TANK AND BEFORE RECEIPT OF TANK BELDING TANK TECHNOLOGIES WILL NOT BE RESPONSIBLE FOR PRE-SET ANCHOR BOLTS. (SEE HANDLING & INSTALLATION INSTRUCTIONS).
  - TANK HOLD DOWN LUGS, FLOOR PLATES OR SADDLES MUST BE SECURELY FASTENED TO FOUNDATION. BELDING TANK TECHNOLOGIES IS NOT RESPONSIBLE FOR HOLD DOWN ANCHOR DESIGN.
  - FLAT AND SLOPE BOTTOM VESSELS TO BE COMPLETELY SUPPORTED BY FOUNDATION. (PER HANDLING & INSTALLATION INSTRUCTIONS).
  - ATMOSPHERIC TANKS MUST BE VENTED DIRECTLY TO ATMOSPHERE. VENT SHOULD NOT BE ROUTED TO OR THROUGH CONSERVATION VENTS, PRESSURE RELIEF VENTS, SCRUBBERS, OR ANY KIND OF VENT RESTRICTION. FAILURE TO FOLLOW THIS GUIDELINE COULD RESULT IN DAMAGE TO THE TANK. IF VENT SCREENS ARE PRESENT THEY SHOULD BE KEPT CLEAN.
  - IF TANK IS TO BE AIR LOADED, FOLLOW GUIDELINES SET FORTH IN BELDING TANK TECHNOLOGIES OPERATION & MAINTENANCE INSTRUCTIONS.
  - ALL PIPING, VALVES AND INSTRUMENTS ATTACHED TO VESSEL FLANGES OR OTHERS SHOULD BE INDEPENDENTLY SUPPORTED. USE FLEXIBLE CONNECTIONS WHERE APPROPRIATE.
  - FLANGE CAUTION: A FLANGE SPACER MUST BE USED WHEN BOLTING ALL F.P. FLANGES TO RAISED FACE FLANGES. USE ONLY FULL FACE GASKETS. DO NOT OVER TORQUE FLANGE BOLTS. (PER HANDLING & INSTALLATION INSTRUCTIONS)
  - ALL BOLTS, GASKET AND ANCHOR BOLTS BY OTHERS UNLESS OTHERWISE NOTED.
  - RESIN COAT ALL CUT EDGES INCLUDING BOLT HOLES.
  - DUE TO INTERIOR SECONDARY BONDING OF DRAIN FITTING, DISHED & SLOPE BOTTOM F.P.P. TANKS WILL NOT PROVIDE 100% COMPLETE DRAINAGE.
  - BELDING TANK RECOMMENDS THAT EACH TANK BE WATER FILLED (HYDRO TESTED) FOR 2 HOUR PERIOD AFTER THE TANK IS INSTALLED AND PRIOR TO USE.

70 W. LONG LAKE RD. SUITE 121  
TROY, MI 48068  
PHONE: (248) 879-9000  
FAX: (248) 879-9090  
[WWW.WAGNERENTERPRISE.COM](http://WWW.WAGNERENTERPRISE.COM)

**WAGNER**  
ENTERPRISE

200 N. GOODING ST. - P.O. BOX 160 -  
BELDING, MICHIGAN 48809-160  
PHONE: (616) 794-1130 FAX: (616) 794-3666  
E-MAIL: [sales@beldingtank.com](mailto:sales@beldingtank.com)  
WEBSITE: [www.beldingtank.com](http://www.beldingtank.com)

**GENERAL ARRANGEMENT**  
**BETHPAGE, NY**

144" DIA. x 216" S.S. x 268" HIGH F.R.P. TANK

DATE: 9/28/2021 ORDER NO. 34755 DRAWN BY: DIZ  
SCALE: NONE MODEL NO. (1) C-DPV-12-15365 CHECKED BY: MWW  
CUSTOMER: ARCADIS  
REV: REF: DWG NO. D-32514 SHEET NO. 1 OF 4

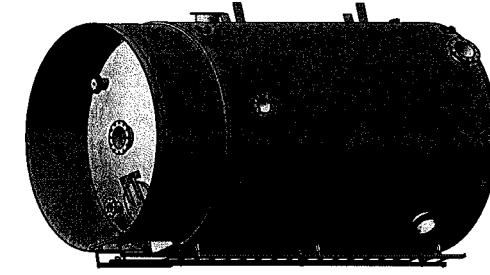

VIEW AT 225°

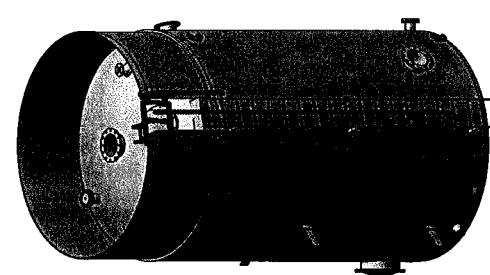

VIEW AT 315°

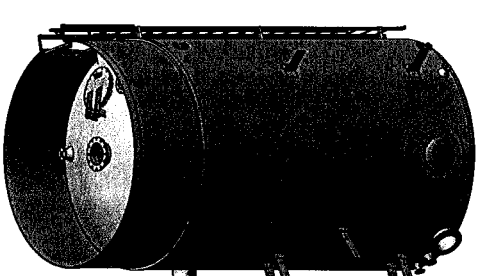

VIEW AT 45°

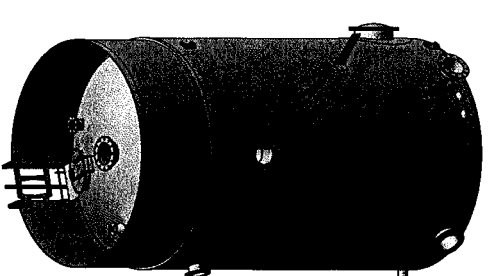

VIEW AT 135°

COMPREHENSIVE ENGINEERING  
4653 PLAINFIELD AVE. NE  
GRAND RAPIDS, MI 49525  
PHONE (616) 365-9833

APPROXIMATE TANK I.D.  
 TOP SIDEWALL I.D.: 146 3/16"  
 BOTTOM SIDEWALL I.D.: 143 1/4"

REV	DESCRIPTION	DATE
3	ROTATED LUGS & N10 PER CUSTOMER MARK UP.	12/20/21
2	CHANGED DOWN PIPE DESIGN.	11/11/21
1	DELETED N1, N9 & N16, ADDED DOWNPIPE TO N13 & BLIND FLANGE TO NS, CHNG. N6 TO 3" F.N., & RELOCATED FITTINGS PER CUSTOMER MARK UP.	10/21/21

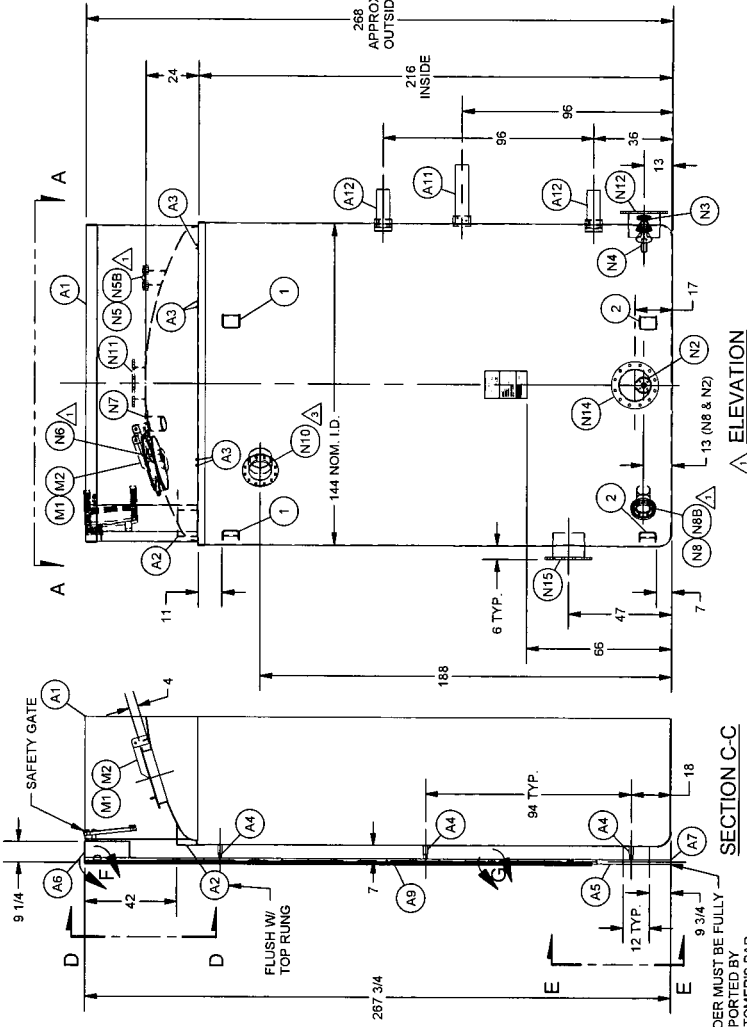
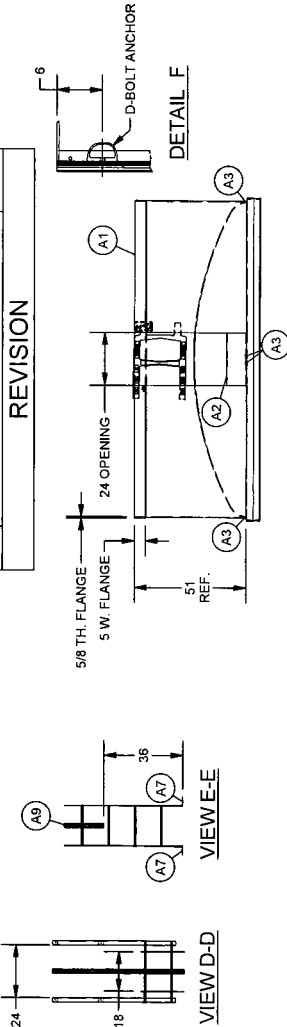

LADDER MUST BE FULLY SUPPORTED BY CUSTOMER'S PAD

ITEM	QTY	DESCRIPTION	MATERIAL
A12	6	3/8" TH. x 6" W. x TO SUIT LG. TWO-PIECE PIPE SUPPORT BRACKETS	F.R.P.
A11	1	3/8" TH. x 6" W. x TO SUIT LG. TWO-PIECE PIPE SUPPORT BRACKET	F.R.P.
A10	3	3/8" TH. x 18" W. x TO SUIT LG. PIPE SUPPORT BRACKETS	F.R.P.
A9	1	SAFETY RAIL ASSEMBLY W/ (2) TROLLIES, D-BOLT ANCHOR, (2) HARNESSSES, & (2) LANYARDS	ANODIZED ALUMINUM
A8	1	LADDER TAG	F.R.P.
A7	2	1/4" TH. x 4" ANGLE x 2" W. LADDER CLIPS	C.S. POLY-U PAINTED SAFETY YELLOW
A6	2	LADDER WALK-THRU	C.S. POLY-U PAINTED SAFETY YELLOW
A5	1	287 3/4" LG. LADDER ASSEMBLY	C.S. POLY-U PAINTED SAFETY YELLOW

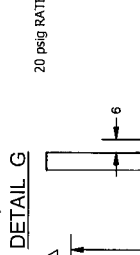

20 psig RATED

REVISED PRINT DATE: 12/20/21

RELEASED FOR FABRICATION DATE: 11-11-21

COMPREHENSIVE ENGINEERING  
 4653 PLAINFIELD AVE. NE  
 GRAND RAPIDS, MI 49525  
 PHONE (616) 365-9933

ITEM	QTY	DESCRIPTION	MATERIAL
A4	6	LADDER MOUNT BRACKETS	F.R.P.
A3	6	1" DIA. SKIRT DRAIN HOLES	F.R.P.
A2	1	STEP-OFF LANDING	F.R.P.
A1	1	SAFETY HANDRAIL ASSEMBLY W/ SKIRT GATE	F.R.P.

ITEM	QTY	DESCRIPTION	MATERIAL
N16		DELETED	
N15	1	14" 150# FLANGED NOZZLE	F.R.P.
N14	1	14" 150# FLANGED NOZZLE	F.R.P.
N13	1	14" 150# FLANGED NOZZLE W/ 14" DIA. DOWNPIPE ASSEMBLY	F.R.P.
N12	1	14" 150# FLANGED NOZZLE	F.R.P.
N11	1	14" 150# FLANGED NOZZLE	F.R.P.
N10	1	16" 150# FLANGED NOZZLE	F.R.P.
N9		DELETED	
N8	1	6" 150# BLIND FLANGE W/ 316 S.S. BOLTS & EPDM GASKET	SCH. 80 PVC
N7	1	6" 150# FLANGED NOZZLE	F.R.P.
N6	1	3" 150# FLANGED NOZZLE W/ CONICAL GUSSET	F.R.P.
N5	1	6" 150# BLIND FLANGE W/ 316 S.S. BOLTS & EPDM GASKET	SCH. 80 PVC
N4	1	2" 150# FLANGED NOZZLE W/ CONICAL GUSSET	F.R.P.
N3	1	2" 150# FLANGED NOZZLE W/ CONICAL GUSSET	F.R.P.
N2	1	2" 150# FLANGED NOZZLE W/ CONICAL GUSSET	F.R.P.
N1		DELETED	

WAGNER ENTERPRISE INC.  
 70 W. LONG LAKE RD. SUITE 121  
 TROY, MI 48068  
 PHONE: (248) 879-9000  
 FAX: (248) 879-9090  
 WWW.WAGNERENTERPRISE.COM

200 N. GOODING ST. - P.O. BOX 160 -  
 BELLEVILLE, MICHIGAN 48809-160  
 PHONE: (616) 794-1130 FAX: (616) 794-3666  
 E-MAIL: sales@belldingtank.com  
 WEBSITE: www.belldingtank.com

DATE: 9/28/2021	ORDER NO.: 34755	DRAWN BY: DJZ	CHECKED BY: DJZ
SCALE: NONE	MODEL NO.: (1) C-DFV-12-1585		
CUSTOMER: ARCADIS			

ELEVATION & SECTIONS PAGE  
 BELPAGE, NY  
 144" DIA. x 216" S.S. x 268" HIGH F.R.P. TANK  
 SHEET NO. D-32514 SHEETING 2 OF 4

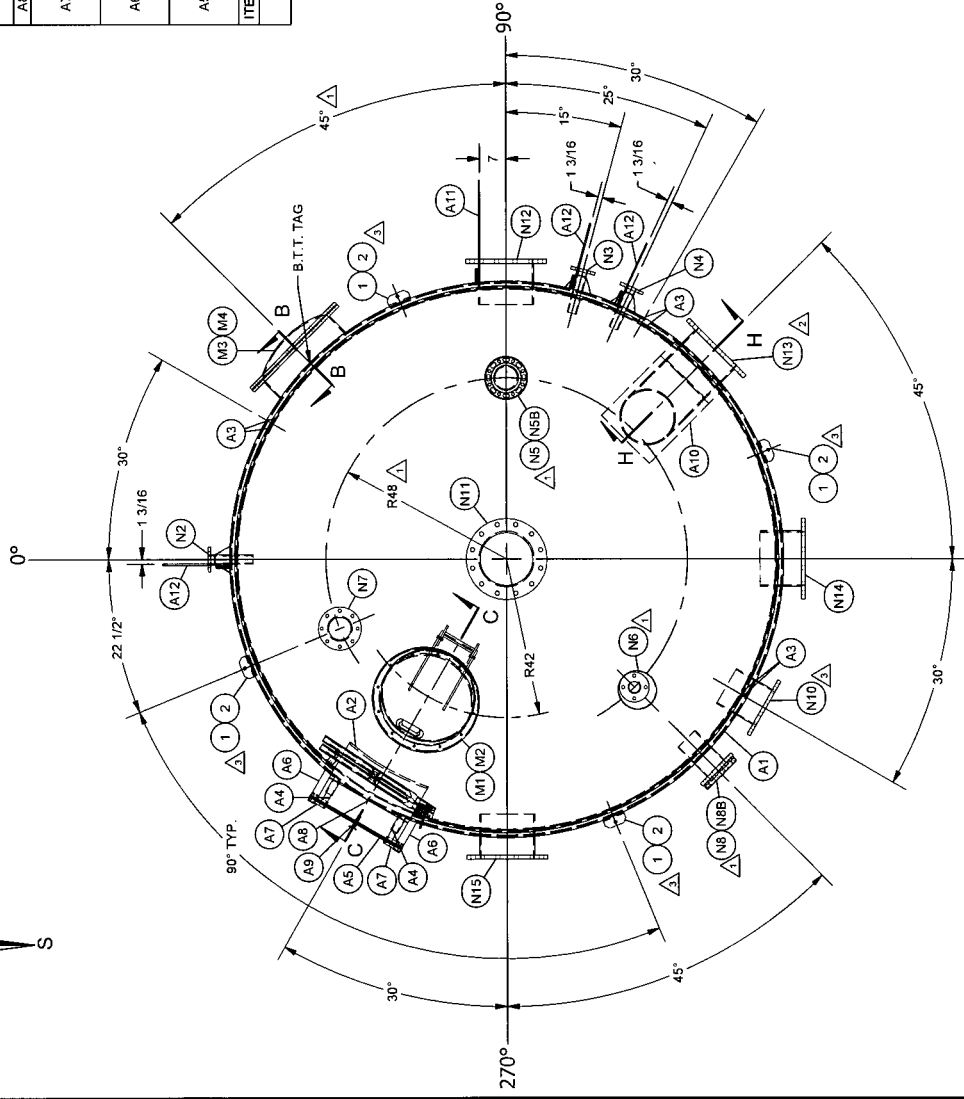
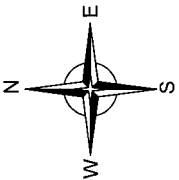

VIEW A-A  
ORIENTATION

ITEM	QTY	DESCRIPTION	MATERIAL
<b>ACCESSORIES</b>			
A12	6	3/8" TH. X 6" W. X TO SUIT LG. TWO-PIECE PIPE SUPPORT BRACKETS	F.R.P.
A11	1	3/8" TH. X 6" W. X TO SUIT LG. TWO-PIECE PIPE SUPPORT BRACKET	F.R.P.
A10	3	3/8" TH. X 18" W. X TO SUIT LG. PIPE SUPPORT BRACKETS	F.R.P.
A9	1	SAFETY RAIL ASSEMBLY W/ (2) TROLLIES, D-BOLT ANCHOR, (2) HARNESSSES, & (2) LANYARDS	ANODIZED ALUMINUM
A8	1	LADDER TAG	F.R.P.
A7	2	1/4" TH. X 4" ANGLE X 2" W. LADDER CLIPS	C.S. POLY-U PAINTED SAFETY YELLOW
A6	2	LADDER WALK-THRU	C.S. POLY-U PAINTED SAFETY YELLOW
A5	1	287 3/4" LG. LADDER ASSEMBLY	C.S. POLY-U PAINTED SAFETY YELLOW

ITEM	QTY	DESCRIPTION	MATERIAL
<b>ACCESSORIES</b>			
A4	6	LADDER MOUNT BRACKETS	F.R.P.
A3	6	1" DIA. SKIRT DRAIN HOLES	F.R.P.
A2	1	STEP-OFF LANDING	F.R.P.
A1	1	SKIRT HANDRAIL ASSEMBLY W/ SAFETY GATE	F.R.P.

ITEM	QTY	DESCRIPTION	MATERIAL
<b>NOZZLES</b>			
M4	1	32" DIA. COVER PLATE W/ 316 S.S. BOLTS & EPDM GASKET	F.R.P.
M3	1	24" DIA. SIDE MANHOLE	F.R.P.
M2	1	28" DIA. HINGED COVER W/ S.S. HANDLE, 316 S.S. BOLTS, & EPDM GASKET	F.R.P.
M1	1	24" DIA. TOP MANHOLE	F.R.P.

ITEM	QTY	DESCRIPTION	MATERIAL
<b>MANHOLES</b>			
2	4	HOLD DOWN LUGS No. 7	316 S.S.
1	4	LIFTING LUGS No. 7	316 S.S.

REV	DESCRIPTION	DATE
3	ROTATED LUGS & N10 PER CUSTOMER MARK UP.	12/20/21 DJZ
2	CHANGED DOWN PIPE DESIGN.	11/11/21 DJZ
1	DELETED N1, N9, & N16. ADDED DOWNPIPE TO N13 & BLIND FLANGE TO N5. CHNG. N6 TO 3" F.N. & RELOCATED FITTINGS PER CUSTOMER MARK UP.	10/21/21 DJZ

RELEASED FOR FABRICATION DATE: 11-11-21

COMPREHENSIVE ENGINEERING  
4853 PLAINFIELD AVE NE  
GRAND RAPIDS, MI 49525  
PHONE (616) 365-9933

REVISED PRINT DATE: 12/20/21

DATE	BY	SCALE	CUSTOMER
9/28/2021	34725	NONE	ARCADIS

ORIENTATION PAGE  
BETHPAGE, NY  
144" DIA. X 216" S.S. X 2568" HIGH F.R.P. TANK  
DATE: 9/28/2021  
DRAWN BY: 34725  
SCALE: NONE  
CUSTOMER: ARCADIS  
DWG. NO. D-32514  
SHEET NO. 3 OF 4

WAGNER ENTERPRISE, INC.  
70 W. LONG LAKE RD. SUITE 121  
TROY, MI 48068  
PHONE: (248) 879-9000  
FAX: (248) 879-9090  
WWW.WAGNERENTERPRISE.COM

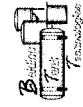

200 N. GOODING ST. - P.O. BOX 180 - BELDING, MICHIGAN 48809-160  
PHONE: (616) 794-1130 FAX: (616) 794-3666  
E-MAIL: sales@beldingtank.com  
WEBSITE: www.beldingtank.com

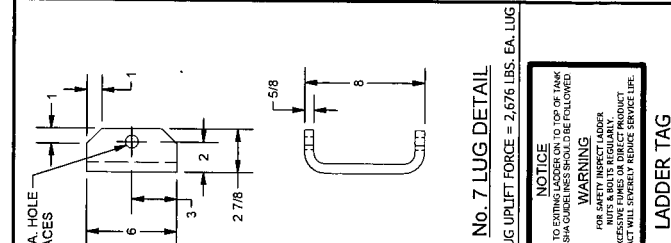

M	d	df	hi	ti	gn	Gusset	LIFT	to Mat	Phys	to Fabmat	Phys	Rating	Type	Sequence
M1	24"	30"	3"	5/16"	3"	None	0	3	3	0	3	Alm	F	3M-30"-SN 3M-30"-SN
M3	24"	48"	3"	3/8"	3"	None	180	3	3	1 1/8"	20 PSI	F	F	3M-30"-SN 3FM-48"-SN 3M-50"-SN
N2	2"	8"	1"	1/4"	CG	203	203	3	3	3/4"	150 psi	P	P	3M-10"-SN 3M-10"-SN
N3	2"	8"	1"	1/4"	CG	203	203	3	3	3/4"	150 psi	P	P	3M-10"-SN 3M-10"-SN
N4	2"	8"	1"	1/4"	CG	203	203	3	3	3/4"	150 psi	P	P	3M-10"-SN 3M-10"-SN
N5	6"	12"	3"	5/16"	None	0	0	3	3	1"	100 psi	F	F	3M-14"-SN 3M-14"-SN
N6	6"	9"	1-1/2"	5/16"	CG	0	0	3	3	7/8"	150 psi	F	F	3M-10"-SN 3M-10"-SN
N7	6"	12"	3"	5/16"	None	0	0	3	3	1"	100 psi	F	F	3M-14"-SN 3M-14"-SN
N8	6"	12"	3"	5/16"	None	203	203	3	3	1"	100 psi	P	P	3M-14"-SN 3FM-14"-SD 3M-16"-SN
N10	10"	16"	3"	5/16"	None	28	28	3	3	1 1/2"	50 psi	F	F	3M-16"-SN 3M-16"-SN
N11	14"	20"	3"	3/8"	None	0	0	3	3	1 1/16"	50 psi	P	P	3M-20"-SN 3M-20"-SN
N12	14"	20"	3"	3/8"	None	203	203	3	3	1 1/16"	50 psi	P	P	3M-20"-SN 3FM-20"-SN 3M-30"-SN
N13	14"	28"	3"	3/8"	None	38	38	3	3	1-1/16"	50 psi	P	P	3M-20"-SN 3M-20"-SN
N14	14"	28"	3"	3/8"	None	199	199	3	3	1-1/16"	50 psi	P	P	3M-20"-SN 3FM-20"-SN 3M-30"-SN
N15	14"	28"	3"	3/8"	None	169	169	3	3	1-1/16"	50 psi	P	P	3M-20"-SN 3FM-20"-SN 3M-30"-SN

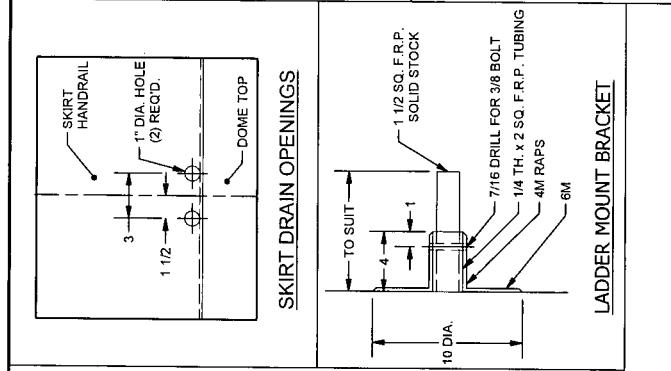

to Mat	Phys	to Fabmat	Phys	Rating	Type	Sequence
3	3	0	3	5/16"	Alm	F
3	3	3	3	1 1/8"	20 PSI	F
3	3	0	3	3/4"	150 psi	P
3	3	0	3	3/4"	150 psi	P
3	3	0	3	3/4"	150 psi	P
3	3	0	3	1"	100 psi	F
3	3	0	3	7/8"	150 psi	F
3	3	0	3	1"	100 psi	F
3	3	0	3	1 1/2"	50 psi	F
3	3	0	3	1 1/16"	50 psi	P
3	3	0	3	1 1/16"	50 psi	P
3	3	0	3	1-1/16"	50 psi	P
3	3	0	3	1-1/16"	50 psi	P
3	3	0	3	1-1/16"	50 psi	P

Notes: LIFT (Liquid Height) is measured from Item to Top of Tank Straight Side.  
 2- Dimension 'A' is 6" when d is larger than 12" and 3" for 12" and smaller.

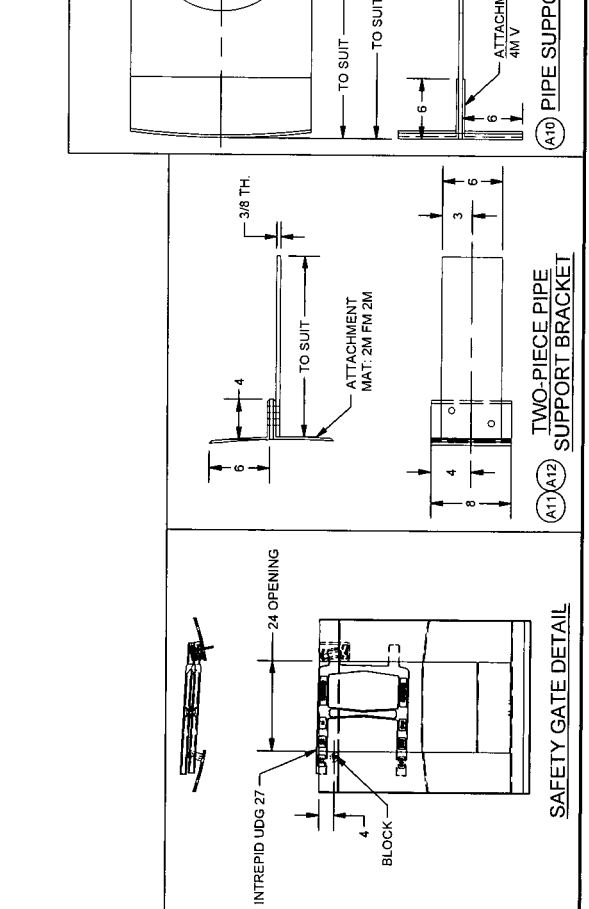
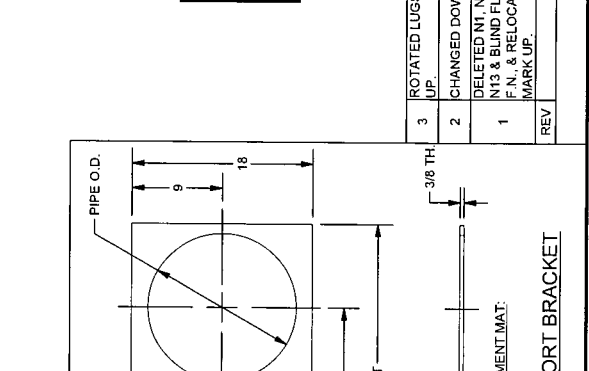
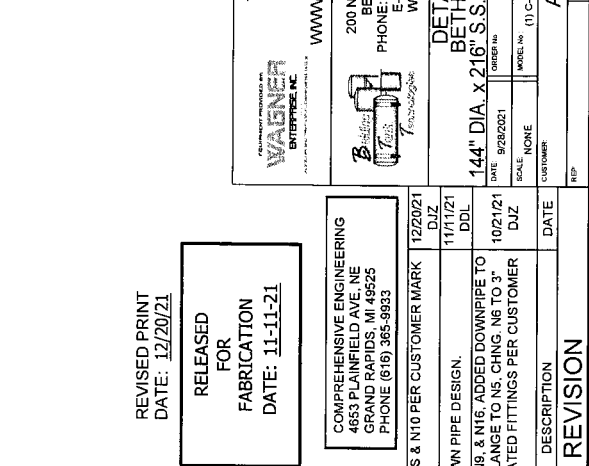
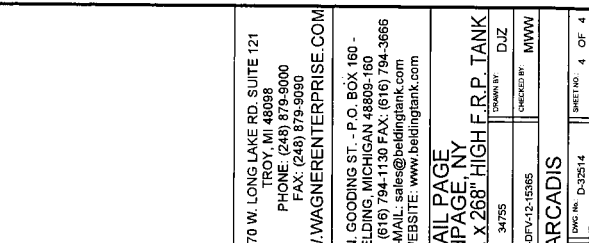

**No. 7 LUG DETAIL**  
 HOLD DOWN LUG UPLIFT FORCE = 2,675 LBS. EA. LUG

**NOTICE**  
 PRIOR TO FIXING LADDER ON TO TOP OF TANK ALL DIMENSIONS MUST BE FOLLOWED

**WARNING**  
 THIS PRODUCT IS NOT TO BE USED FOR LUGS, RISERS & BULBS REGULARLY. EXCESSIVE TURNS ON DIRECT PRODUCT CONTACT WILL REDUCE SERVICE LIFE.

**LADDER TAG**

**DETAIL PAGE**  
 BETHPAGE, NY  
 144" DIA. x 216" S.S. x 268" HIGH F.R.P. TANK

70 W. LONG LAKE RD. SUITE 121  
 TROY, MI 48068  
 PHONE: (248) 879-9000  
 FAX: (248) 879-9090  
 WWW.WAGNERENTERPRISE.COM

200 N. GOODING ST. - P.O. BOX 160 -  
 BELDING, MICHIGAN 48809-160  
 PHONE: (616) 794-1130 FAX: (616) 794-3666  
 E-MAIL: sales@beldingtank.com  
 WEBSITE: www.beldingtank.com

REVISED PRINT DATE: 12/20/21  
 RELEASED FOR FABRICATION DATE: 11-11-21

COMPREHENSIVE ENGINEERING  
 4653 PLAINFIELD AVE. NE  
 GRAND RAPIDS, MI 49525  
 PHONE (616) 365-9833

REV	DESCRIPTION	DATE
3	ROTATED LUGS & N10 PER CUSTOMER MARK UP.	12/20/21
2	CHANGED DOWN PIPE DESIGN.	11/11/21
1	DELETED N1, N8, & N16. ADDED DOWNPIPE TO N13 & BLIND FLANGE TO NS. CHNG. NR TO 3" F.N. & RELOCATED FITTINGS PER CUSTOMER MARK UP.	10/21/21

**REVISION**

ARCADIS

DWG. No. D-32514

SHEET No. 4 OF 4

**ATTACHMENT 3.2**

**CONCEPTUAL NEW PROCESS EQUIPMENT**

**HYDROGEN PEROXIDE TANK - PEABODY**

8 7 6 5 4 3 2 1

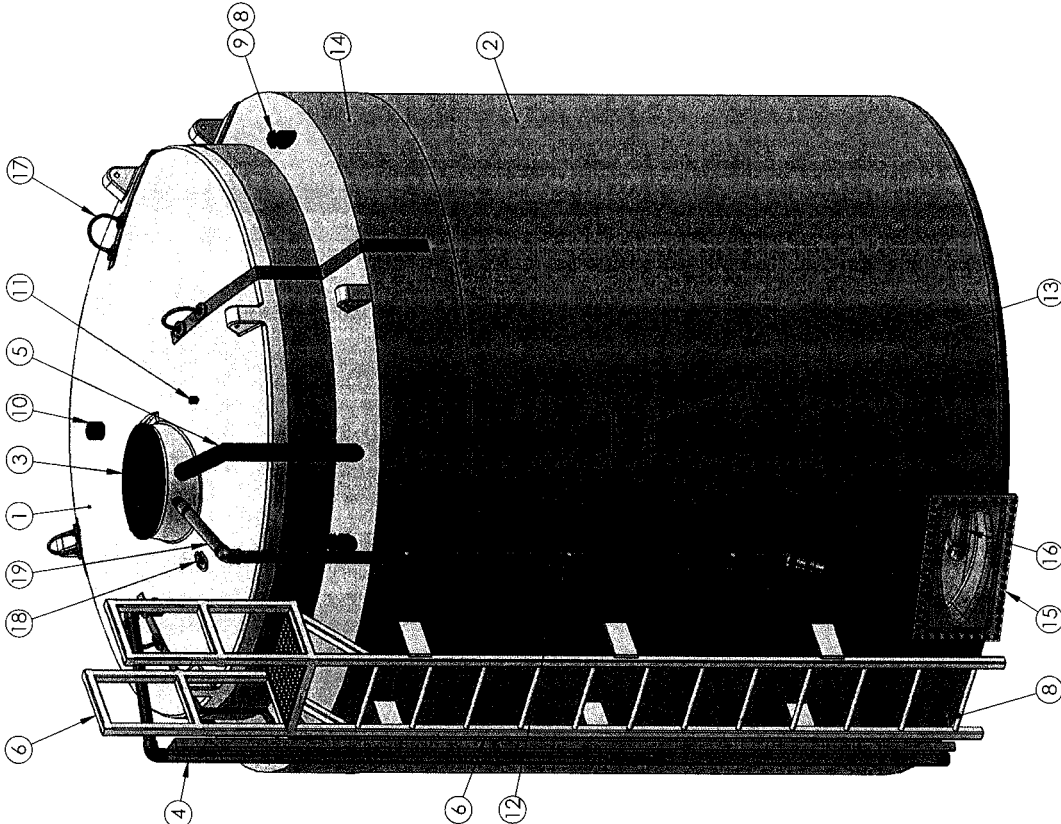

**TOP LEVEL ASSEMBLY**

ITEM NO.	DESCRIPTION	QTY.
1	7800 GAL VERTICAL TANK, INNER	1
2	10000 GAL VERTICAL TANK, OUTER	1
3	24" PRESSURE RELIEF LID	1
4	INVERSE LEVEL INDICATOR W/ CALIBRATION CHART	1
5	OVERFLOW PIPE, 3"	1
6	LADDER ASSEMBLY	1
7	INTERSTITIAL SPACER PIPE, 8" O.D.	10
8	HALF COUPLER, Ø2"	5
9	VENT, 2"	4
10	FULL COUPLER, Ø2" (NO CBORE)	1
11	FULL COUPLER, 1/2"	1
12	PIPE CLAMP ASSEMBLY, 2"	3
13	IDENTIFICATION PLACARD	1
14	3/16" FRP WRAP	1
15	LEAK INSPECTION PORT BOX ASSEMBLY, MOLDED TEAR DROP CONFIGURATION	1
16	SS FLEX HOSE ASSEMBLY	1
17	LIFTING LUG ASSEMBLY	4
18	"D" RING-STYLE LUG	1
19	FILL LINE, 2", 316 SS. (PROVIDED BY USP, INSTALLED BY PEABODY)	1

**NOTES:**  
 1. CAPACITY: 7800 GAL. NOMINAL  
 2. APPROXIMATE WEIGHT: 6894.55 LBS  
 3. TANK MATERIAL: HDLPE W/ UV INHIBITOR  
 4. GASKETS: VITON/TEALON  
 5. SERVICE PRESSURE: ATMOSPHERIC

**ISO VIEW**

UNLESS OTHERWISE SPECIFIED: DIMENSIONS ARE IN INCHES TO DECIMALS		NAME RWS	DATE 11/8/11
FRACTIONAL ± .5" ONE PLACE DECIMAL ± .063" TWO PLACE DECIMAL ± .010" THREE PLACE DECIMAL ± .015"		DRAWN	CHECKED
TANK MATERIAL: HDPE INNER TANK S/N: OTHER TANK S/N: CUSTOMER P.O.P.		ENG APPR.	MFG APPR.
PROPERTY AND CONFIDENTIAL THE INFORMATION CONTAINED IN THIS DRAWING IS THE SOLE PROPERTY OF PEABODY ENGINEERING. ANY REPRODUCTION IN PART OR AS A WHOLE WITHOUT THE WRITTEN PERMISSION OF PEABODY ENGINEERING IS PROHIBITED.		O.A.	COMMENTS:
DO NOT SCALE DRAWING		PEABODY engineering PROJECT: 7800 DC, USP, GENERAL USE DRAWING CUSTOMER: SITE/LOCATION: DRAWING: USP	
SCALE: 1:96		SIZE: DECK	REV. F
SHEET 1 OF 4		7800 DC, VERTICAL TANK ASSEMBLY, USP	

8 7 6 5 4 3 2 1

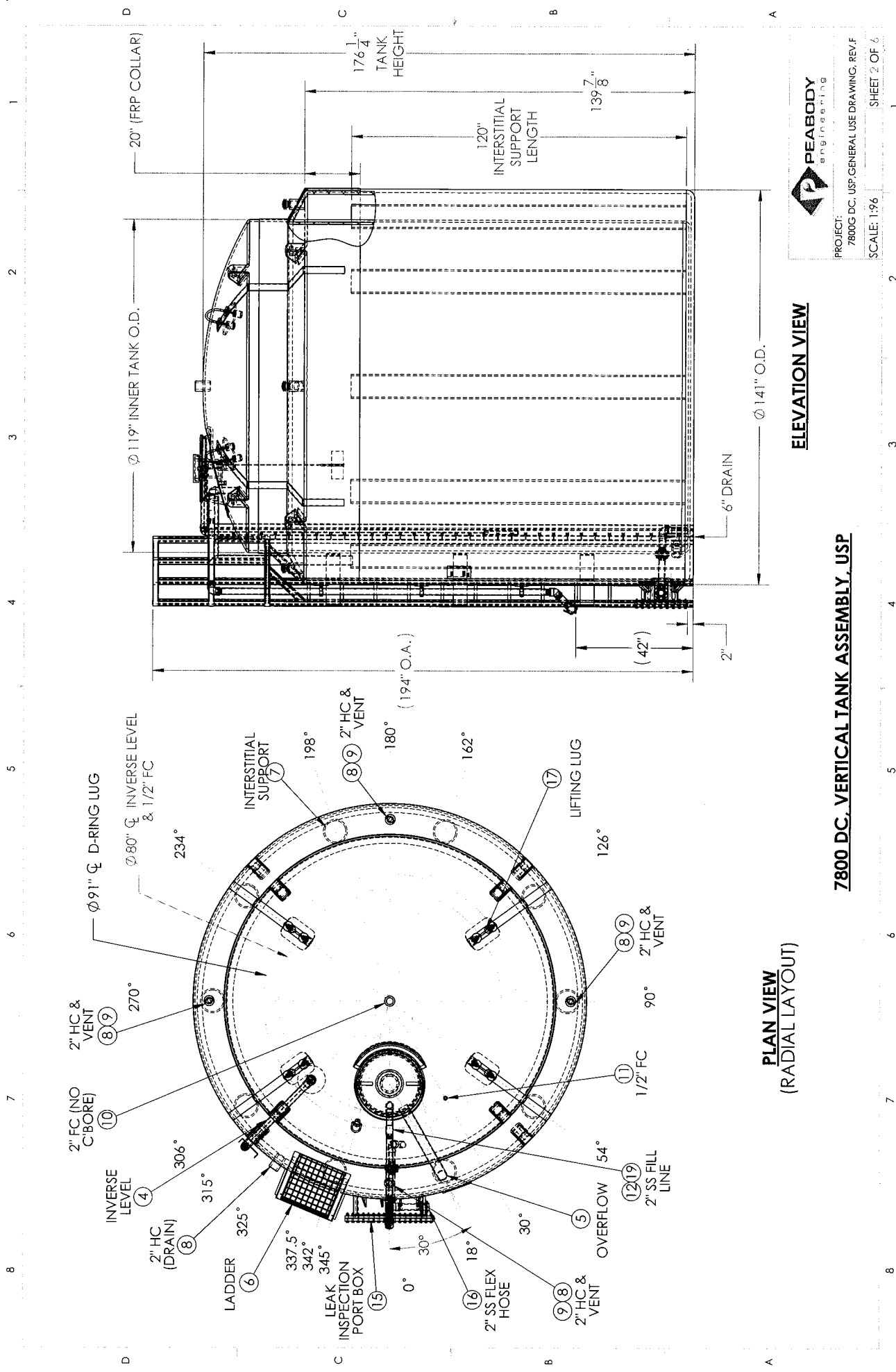

**PEABODY**  
engineering

PROJECT:  
7800G DC, USP GENERAL USE DRAWING, REV.F

SCALE: 1:96

SHEET 2 OF 6

**7800 DC, VERTICAL TANK ASSEMBLY, USP**

**PLAN VIEW (RADIAL LAYOUT)**

**ELEVATION VIEW**

**ATTACHMENT 3.3**

**CONCEPTUAL NEW PROCESS EQUIPMENT**

**AOP – TROJANUV FLEX 100**



- NOTES:
- : UV CHAMBER MATERIAL TO BE TYPE 2205 DUPLEX.
  - : STANDARD OPERATING PRESSURE TO BE 60 PSI [4 BAR].
  - : OPTIONAL RATINGS OF 125 PSI [8.6 BAR] AVAILABLE.
  - : TROJAN RECOMMENDS THAT VALVES ARE USED TO ISOLATE THE UV CHAMBER FROM PLANT FLOW FOR SERVICING.
  - : (NOTE: LAMP CHANGE OUT CAN BE DONE ON-LINE).
  - : OPTIONAL FLANGE RATINGS AVAILABLE, AMWA CLASS B (SHOWN), AMWA CLASS D, PN6, PN10.
  - : RIGHT SIDE LAMP REMOVAL AND LEFT SIDE LAMP ORIENTATIONS AVAILABLE:
  - : FLOW DIRECTION CAN BE EITHER DIRECTION. LEFT TO RIGHT SHOWN.
  - : CHAMBER WEIGHT DRY 5563 LBS [2523 KGS] / WET 11654 LBS [5286 KGS].
  - : FACTORY INSTALLED LAMP CABLES BETWEEN LDP AND CHAMBER NOT SHOWN.
  - : MINIMUM OF FIVE STRAIGHT PIPE DIAMETERS OF PIPING REQUIRED UPSTREAM AND THREE REQUIRED DOWNSTREAM.

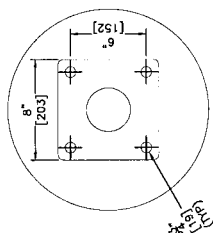

**FOOT DETAIL**  
SCALE: NOT TO SCALE

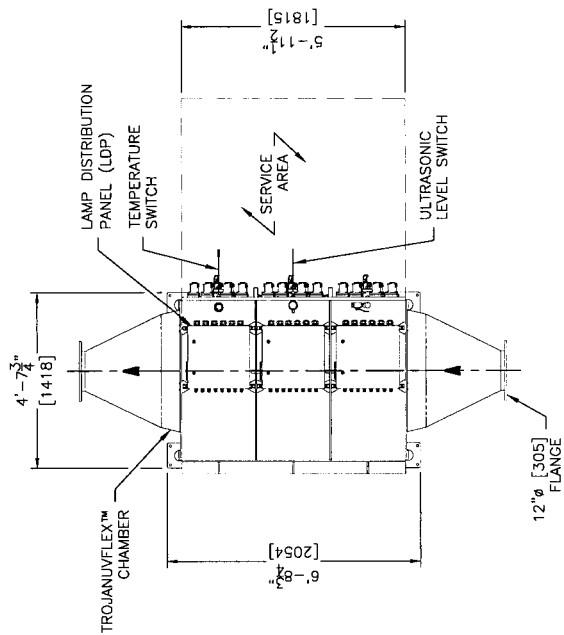

**PLAN VIEW**  
SCALE: NOT TO SCALE

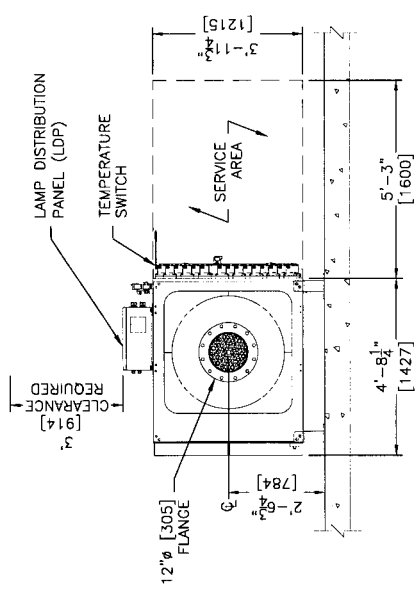

**INLET VIEW**  
SCALE: NOT TO SCALE

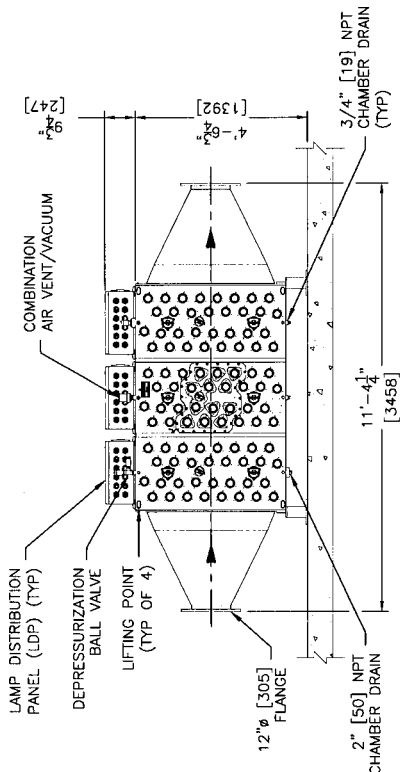

**SIDE VIEW**  
SCALE: NOT TO SCALE

<b>TROJANUV</b> <small>UV TECHNOLOGIES</small>	<b>DESCRIPTION:</b> STD. TROJANUVFLEX100 3 BANK, HORIZONTAL LAMP, 12" [305] FLANGE		STD. DRAWING NO. <b>FL100H1203</b>
	DRAWN BY : AMM CHECKED BY : RLM APPROVED BY : SPM	DATE : 30MR31 DATE : 20MR05 DATE : 20MR05	REFERENCE NO. <b>822620G</b>
CONFIDENTIALITY NOTICE Copyright © 2020 by Trojan Technologies. All rights reserved. No part of this document may be reproduced, stored in a retrieval system, or transmitted in any form, without the written permission of Trojan Technologies.		LOG NUMBER : N/A	

**ATTACHMENT 3.4**

**CONCEPTUAL NEW PROCESS EQUIPMENT**

**BAG FILTERS – COMMERCIAL FILTRATION SUPPLY**

### Applications

Coarse filtration > 500 µm	✓
Medium filtration > 10 µm	✓
Fine filtration < 10 µm	✓

Pre-filtration	✓
Safety filtration	✓
High volume	✓
Batch filtration	✓
Circuit filtration	✓
Continuous filtration	

Solvents, paints	✓
Fats and oils	✓
Catalyst, activated carbon	
Acids, bases	✓
Petrochemicals	✓
Water, waste water	✓
Chemical industry	✓

Pharmaceuticals	
Metal cleaning	✓
Automotive	✓
Electronics	

Food and beverage	
Paint and lacquer	✓
Water treatment	✓
Galvanic industry	

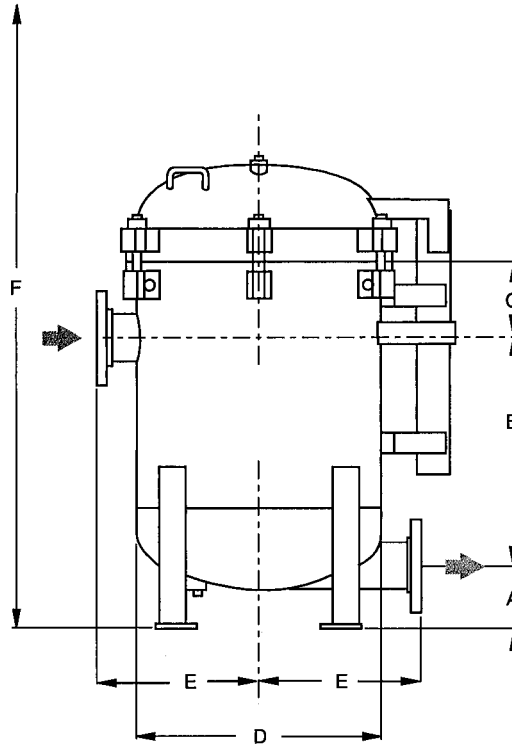

Dimensions - inch (mm)

Models	A	B	C	D	E	F
MBF-0302	6.00 (152)	22.50 (572)	6.43 (163)	18.00 (457)	12.75 (324)	60.00 (1,524)
MBF-0402	6.00 (152)	22.19 (564)	7.93 (201)	24.00 (610)	16.00 (406)	70.00 (1,778)
MBF-0602	7.00 (178)	20.00 (508)	9.81 (249)	26.00 (660)	18.50 (470)	74.00 (1,880)
MBF-0802	8.25 (210)	19.00 (483)	10.81 (275)	30.00 (762)	20.50 (521)	79.50 (2,019)

Dimensions for reference only and approximate. Exact dimensions for installation purposes available on request. The 8 bag loop style dimensions are available on the Eaton website.

### Technical data

Models	No. of filter bags	Size	Flow rate <sup>1</sup> GPM (m <sup>3</sup> /h)	Max. pressure psi (bar)	Max. temp. °F (°C)	Housing volume gal (l)	Housing weight lb (kg)	I/O connections
MBF-0302*	3	2	225 (51)	150 (10)	250 (121)	40 (151)	460 (227)	3"
MBF-0402	4	2	400 (91)	150 (10)	250 (121)	69 (261)	615 (279)	4"
MBF-0602*	6	2	900 (204)	150 (10)	250 (121)	90 (341)	810 (367)	6"
MBF-0802	8	2	1409 (320)	150 (10)	250 (121)	116 (439)	970 (440)	8"

<sup>1</sup> Maximum theoretical flow based on water viscosity, filter bag specific.

US  
EF-FBH-06  
6-2015

### Request a Quote:

Commercial Filtration Supply

1444 E. Main St., Rock Hill, SC 29730

Tel: (855) 236-0467

Email: [info@commercialfiltrationsupply.com](mailto:info@commercialfiltrationsupply.com)



**ATTACHMENT 3.5**

**CONCEPTUAL NEW PROCESS EQUIPMENT**

**LGAC TANKS – TETRASOLV FILTRATION**

		VALVE OPERATION MODE												
		A1	A2	A3	A4	A5	A6	B1	B2	B3	B4	B5	B6	X1
MODE OF OPERATION		OPEN	CLOSED	CLOSED	CLOSED	CLOSED	CLOSED	CLOSED	CLOSED	CLOSED	CLOSED	CLOSED	CLOSED	CLOSED
UNIT A (ONLY) OPERATION		CLOSED	CLOSED	CLOSED	CLOSED	CLOSED	CLOSED	CLOSED	CLOSED	CLOSED	CLOSED	CLOSED	CLOSED	CLOSED
UNIT B (ONLY) OPERATION		CLOSED	CLOSED	CLOSED	CLOSED	CLOSED	CLOSED	CLOSED	CLOSED	CLOSED	CLOSED	CLOSED	CLOSED	CLOSED
SERIES FLOW OPERATION UNIT A TO UNIT B		CLOSED	CLOSED	CLOSED	CLOSED	CLOSED	CLOSED	CLOSED	CLOSED	CLOSED	CLOSED	CLOSED	CLOSED	CLOSED
SERIES FLOW OPERATION UNIT B TO UNIT A		CLOSED	CLOSED	CLOSED	CLOSED	CLOSED	CLOSED	CLOSED	CLOSED	CLOSED	CLOSED	CLOSED	CLOSED	CLOSED
PARALLEL FLOW OPERATION UNIT A & B		CLOSED	CLOSED	CLOSED	CLOSED	CLOSED	CLOSED	CLOSED	CLOSED	CLOSED	CLOSED	CLOSED	CLOSED	CLOSED
UNIT A ONLY BACKWASH		CLOSED	CLOSED	CLOSED	CLOSED	CLOSED	CLOSED	CLOSED	CLOSED	CLOSED	CLOSED	CLOSED	CLOSED	CLOSED
UNIT B ONLY BACKWASH		CLOSED	CLOSED	CLOSED	CLOSED	CLOSED	CLOSED	CLOSED	CLOSED	CLOSED	CLOSED	CLOSED	CLOSED	CLOSED
UNIT A FILTER TO WASTE		CLOSED	CLOSED	CLOSED	CLOSED	CLOSED	CLOSED	CLOSED	CLOSED	CLOSED	CLOSED	CLOSED	CLOSED	CLOSED
UNIT B FILTER TO WASTE		CLOSED	CLOSED	CLOSED	CLOSED	CLOSED	CLOSED	CLOSED	CLOSED	CLOSED	CLOSED	CLOSED	CLOSED	CLOSED

NOTES:  
 1. SYSTEM DESIGNED FOR 125 PSIG, 12" DIAMETER, 20,000 LB LIQUID GAC VESSELS  
 2. MAX FLOW IN PARALLEL 1400 GPM, SERIES 700 GPM  
 3. APPROX SYSTEM WEIGHT:  
 EMPTY - 49,500 LBS  
 FULL - 190,000 LBS

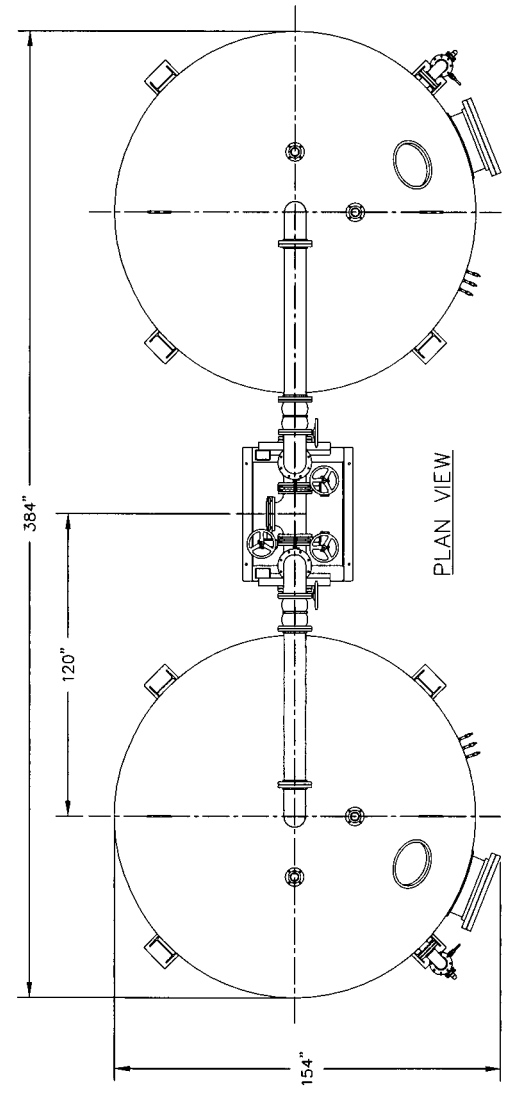

PLAN VIEW

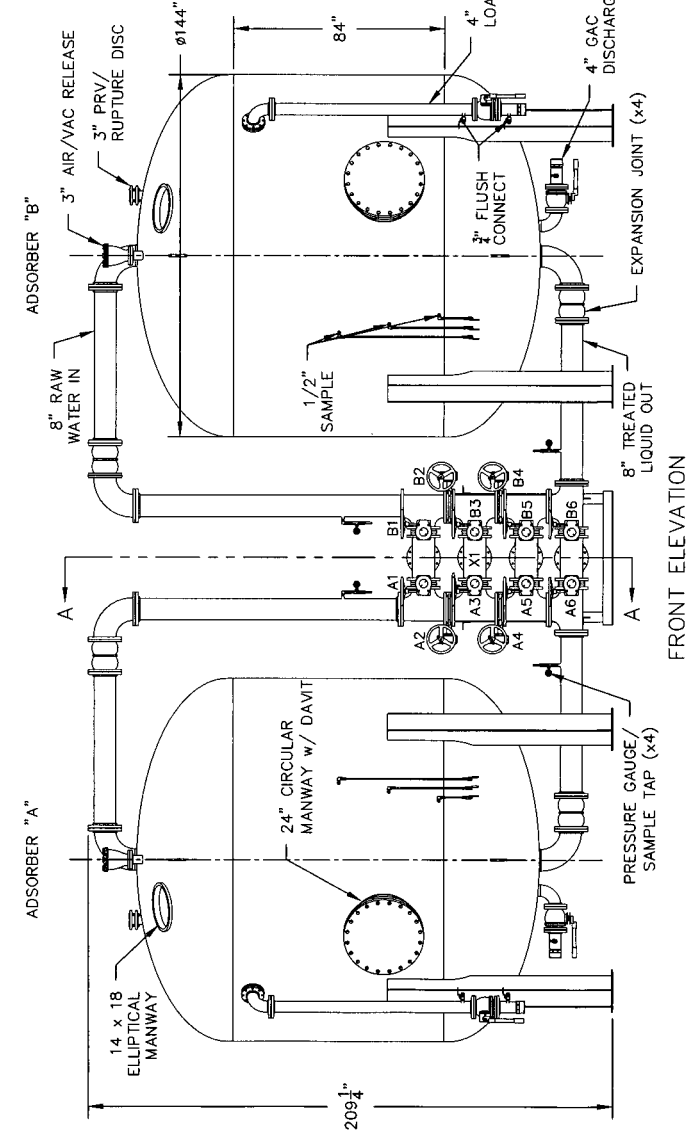

FRONT ELEVATION

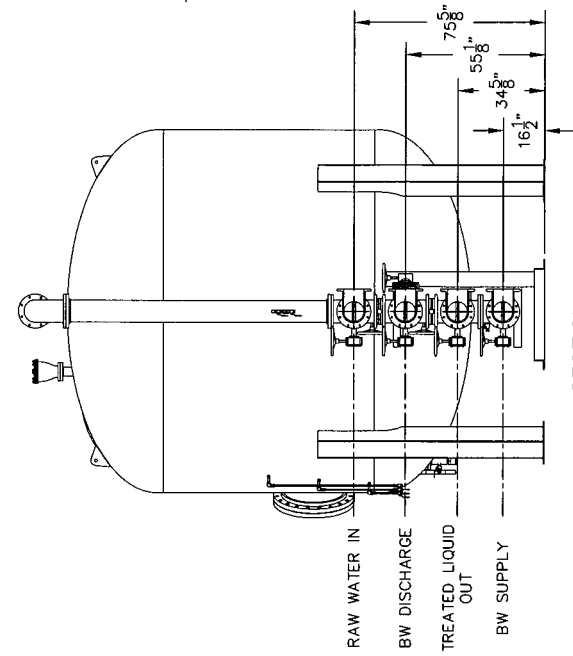

SECTION A-A

USL ABRAMSON ENGINEERING  
 AMHERST, MASSACHUSETTS 01003  
 PH: (781) 463-7843  
 FX: (781) 463-7844

REV#	REVISION/DATE	DATE	SIGNATURE
1			
2			
3			
4			
5			

ALL INFORMATION CONTAINED IN THIS DOCUMENT IS PROPERTY OF TETRA SOLV. IT MAY NOT BE REPRODUCED WITHOUT PERMISSION.

CUSTOMER: TBD  
 DESIGNED BY: S. BULCHINGTON  
 APPROVED BY: \_\_\_\_\_

JOB # : TBD  
 DATE : 9/1/20  
 SCALE : 1/4"=1'

QUANTITY : 2  
 UNITS : IPS  
 DRAWING # : D-1-R-D

L144\_SYSTEM

**ATTACHMENT 3.6**

**CONCEPTUAL NEW PROCESS EQUIPMENT**

**AIX – TANKS - AEDGE**

PRELIMINARY: NOT FOR CONSTRUCTION

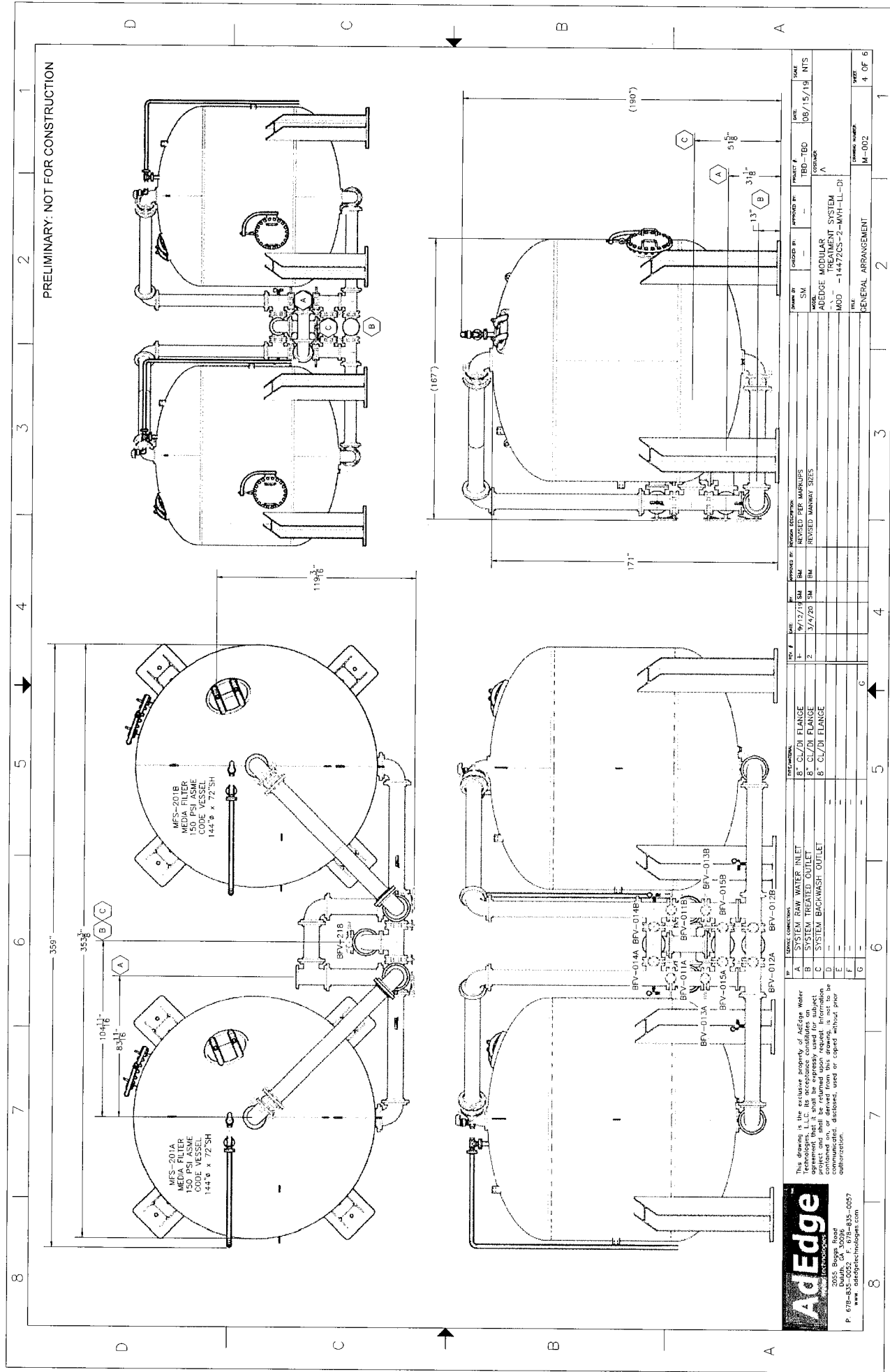

NO. / DATE	BY	APPROVED BY	REVISIONS	PROJECT #	DATE	SCALE
1 / 9/13/18	SM	BM	REVISED PER MARKUPS	TBD-180	08/15/19	NTS
2 / 3/4/20	SM	BM	REVISED MAINWAY SIZES	TBD-180	08/15/19	NTS

NO.	DESCRIPTION	DATE
1	SYSTEM RAW WATER INLET	
2	SYSTEM TREATED OUTLET	
3	SYSTEM BACKWASH OUTLET	
4		
5		
6		
7		
8		

DATE	BY	APPROVED BY	REVISIONS	PROJECT #	DATE	SCALE
08/15/19	SM	BM	REVISED PER MARKUPS	TBD-180	08/15/19	NTS
08/15/19	SM	BM	REVISED MAINWAY SIZES	TBD-180	08/15/19	NTS

NO.	DESCRIPTION	DATE
1	ADEDGE MODULAR TREATMENT SYSTEM	
2	MOD - 14472CS-2-MVH-L-D	
3		
4		
5		
6		
7		
8		

NO.	DESCRIPTION	DATE
1	GENERAL ARRANGEMENT	
2		
3		
4		
5		
6		
7		
8		

**AdEdge**  
 TECHNOLOGIES, LLC  
 2045 Rogers Road  
 Dunwoody, GA 30096  
 P: 678-851-2000  
 www.adedgetechnologies.com