

Mr. Steven Scharf, P.E.  
New York State Department of Environmental Conservation  
Remedial Action, Bureau A  
Division of Environmental Remediation  
625 Broadway  
Albany, New York 12233-7015

Subject:

System Start-up Work Plan, Northrop Grumman Groundwater Interim Remedial Measure, Operable Unit 3 (Former Grumman Settling Ponds) Bethpage, New York.

Dear Mr. Scharf:

ARCADIS is submitting this System Start-up Work Plan on behalf of the Northrop Grumman Systems Corporation (Northrop Grumman). This Work Plan describes the proposed Operable Unit 3 (OU3) Groundwater Interim Remedial Measure (GW IRM) system start-up program. Figure 1 depicts the site location (Site is defined as the Bethpage Community Park and former Northrop Grumman Plant 24 Access Road, which abuts the Park to the south and west).

The objectives of this System Start-up Work Plan are:

- Describe the three phases of the system start-up program and the tentative schedule for system start-up.
- Present the system and groundwater sampling and monitoring programs associated with system start-up, which includes the long-term sampling and monitoring programs as part of the continuous operation phase.

### **SYSTEM START-UP PROGRAM**

The GW IRM System Start-up Program consists of the following three phases:

- One-hour pilot-test.
- Intermittent operation (system shakedown and alarms/controls testing).
- Continuous operation.

In summary, A New York State Department of Environmental Conservation (NYSDEC)-required, 1-hour pilot test will be performed prior to any water being discharged to the Nassau County Department of Public Works (NCDPW) recharge basins (NCDPW Basins). Once the discharge of treated water to the NCDPW Basins is allowed, there will be a brief (approximately one week) period where the

ARCADIS  
Two Huntington Quadrangle  
Suite 1S10  
Melville  
New York 11747  
Tel 631.249.7600  
Fax 631.249.7610  
[www.arcadis-us.com](http://www.arcadis-us.com)

ENVIRONMENT

Date:

May 6, 2009

Contact:

William S. Wittek, PE

Phone:

631-391-5270

Email:

[william.wittek@arcadis-us.com](mailto:william.wittek@arcadis-us.com)

Our ref:

NY001491.0000.00012

system will be operated intermittently to shakedown any potential problems with the groundwater recovery system and the treatment plant. Upon completion of the system shakedown phase, the system will be operated continuously.

### **Schedule**

Based on available information, the tentative schedule for the GW IRM System Start-up is:

- 1-hr pilot test: scheduled to be performed Thursday May 7, 2009.
- Intermittent Operation; will start on (or about) Tuesday May 19, 2009 (The day after a NC board meeting where the proposed discharge agreement between NG and NC is scheduled to be voted on. Schedule assumes that the proposed agreement is confirmed/accepted.)
- Continuous Operation: will start when the system is checked out/shaken down and deemed ready for continuous operation (expected to be during the week starting May 25, 2009).

### **One-Hour Pilot Test**

The NYSDEC requires that a one-hour pilot test be performed prior to the discharge of treated water to the NCDPW basins to confirm that the treatment system (air stripper and bag filters) will reduce site-related compounds to levels below allowable discharge limits.

During the pilot test, the GW IRM will be operated to simulate normal operation for a period of one hour. At the end of the one hour period, confirmatory samples will be collected.

Specifically; groundwater will be pumped from the four remedial wells (RW-1, RW-2, RW-3, and RW-4) at their respective design pumping rates of 30, 75, 75, and 30 gallons per minute (gpm) to the treatment plant for treatment. The groundwater will be treated by the air stripper, to remove volatile organic compounds (VOCs) to acceptable levels, and then treated by the bag filters, to remove particulate matter. During the one-hour pilot test, the treated water will be temporarily stored in a 20,000-gallon storage tank. The treated water will ultimately be discharged to the NCDPW sanitary sewer system per Northrop Grumman's existing agreement with the NCDPW. The air stripper off-gas will be pumped through all four of the treatment emissions control units (ECUs), where the VOCs will be removed from the vapor stream, prior to discharge to the atmosphere, either by the vapor phase granular activated carbon (GAC) or the potassium permanganate- impregnated zeolite (PPZ).

### **Intermittent and Continuous Operation**

As noted above, once NYSDEC and NCDPW approvals have been received, the system will be operated intermittently to allow for system alarms, instrumentation, and controls to be tested to ensure proper operation prior to continuous operation of the plant. Once the intermittent phase of operation is complete, the system will be operated continuously.

### **SAMPLING AND MONITORING PROGRAMS**

The sampling and monitoring programs for the system start-up and for continuous operation are summarized on Tables 1 and 2 (attached). Table 1 presents the sampling and monitoring associated with the treatment plant to ensure proper system performance and compliance associated with the plant effluents. Table 2 presents the groundwater monitoring program, implemented for assessing the effectiveness of the GW IRM to meet project objectives. The locations of the groundwater monitoring wells and piezometers are shown on Figure 1 and the system sampling and monitoring locations are schematically represented, where possible, on Figure 2.

### **System Start-up (one-hour pilot test)**

During the one-hour pilot test, the following grab samples will be collected, and analyzed for the parameters shown, at the end of the one-hour pilot test:

- Plant Influent (water): pH, VOCs, Iron, and Mercury
- Air Stripper Effluent (water): Iron
- Plant Effluent (water): pH, VOCs, Iron, and Mercury
- Plant Effluent (air): VOCs

The water samples will be submitted to a state-certified laboratory and analyzed for the parameters listed above, except for pH, which will be measured in the field. Samples will be collected and analyzed in accordance with the methods specified in Table 1.

The effluent air sample will be submitted to a state-certified laboratory, and analyzed in accordance with the methods and procedures specified in Table 1.

### **Continuous Operation**

The sampling program (location, frequency, parameter, and analytical method) for the treatment plant is provided in Table 1. In summary, the sampling frequency is split into the following three sections:

- Short-term (first month)
- Short-term (next five months)
- Long-term (after the first six months)

This allows selected samples to be collected more frequently during the initial stages of operation to confirm adherence to project discharge requirements. For example, during the first month; the plant effluent (water) is sampled on Days 1 and 3, then weekly thereafter.

The system water samples will be collected and analyzed in accordance with the methods and procedures specified in Table 1.

The groundwater monitoring program is provided in Table 2. Water-levels will be measured to the nearest hundredth of a foot (.01 ft) (using a decontaminated water level indicator) in the wells in the hydraulic measurement network (Table 2), consistent with NYSDEC-approved OU3 RI/FS procedures.

Groundwater samples will be collected and analyzed in accordance with the procedures and methods specified in Table 2.

We would appreciate NYSDEC written approval of this work plan as soon as possible. If you have any questions or comments, please feel free to contact us.

Sincerely,

ARCADIS



William S. Wittek, PE  
Senior Engineer

Enclosures

Copies:

John Cofman, Northrop Grumman  
Kent A. Smith, Northrop Grumman  
Gary Litwin, NYSDOH  
Robert Weitzman, NCDOH  
Peter A. Scully, NYSDEC Region 1  
Rosalie K. Rusinko, Esq., NYSDEC  
File Repository (Bethpage Public Library)

# ARCADIS

Table 1. Treatment System Monitoring Program, Groundwater Interim Remedial Measure, Operable Unit 3 (Former Grumman Settling Ponds), Northrop Grumman Systems Corporation, Bethpage, New York. (1)

Sample Location/Instrument <sup>(1)</sup>	Parameter (Method) <sup>(2)</sup>	Frequency			SCADA Data Acquisition
		Short-Term <sup>(3)</sup> (first month)	(five month period following first month)	Long-Term <sup>(4)</sup>	
<b><u>Water Samples</u> <sup>(5)</sup></b>					
Remedial Well 1 (WSP-1)	VOCs (NYSDEC 2000 OLM 4.2) Iron (NYSDEC ILM 4.1)	Bi-Weekly Bi-Weekly	Quarterly Annually	Quarterly Annually	NA NA
Remedial Well 2 (WSP-2)	VOCs (NYSDEC 2000 OLM 4.2) Iron (NYSDEC ILM 4.1)	Bi-Weekly Bi-Weekly	Quarterly Annually	Quarterly Annually	NA NA
Remedial Well 3 (WSP-3)	VOCs (NYSDEC 2000 OLM 4.2) Iron (NYSDEC ILM 4.1)	Bi-Weekly Bi-Weekly	Quarterly Annually	Quarterly Annually	NA NA
Remedial Well 4 (WSP-4)	VOCs (NYSDEC 2000 OLM 4.2) Iron (NYSDEC ILM 4.1)	Bi-Weekly Bi-Weekly	Quarterly Annually	Quarterly Annually	NA NA
Air Stripper Influent (WSP-5)	VOCs (NYSDEC 2000 OLM 4.2) Iron (NYSDEC ILM 4.1)	1-hr <sup>(6)</sup> ; Days 1, 3, & Weekly 1-hr <sup>(6)</sup> ; Days 1, 3, & Weekly	Monthly Monthly	Quarterly Quarterly	NA NA
Air Stripper Effluent (WSP-6)	Iron (NYSDEC ILM 4.1)	1-hr <sup>(6)</sup> ; As Needed	As Needed	As Needed	NA
Plant Effluent (WSP-7)	VOCs (NYSDEC 2000 OLM 4.2) Iron (NYSDEC ILM 4.1) ph (field)	1-hr <sup>(6)</sup> ; Days 1, 3, & Weekly 1-hr <sup>(6)</sup> ; Days 1, 3, & Weekly 1-hr <sup>(6)</sup> ; Days 1, 3, & Weekly	Monthly Monthly Monthly	Monthly Monthly Monthly	NA NA NA
<b><u>Air Samples</u> <sup>(7)</sup></b>					
Air Stripper Effluent/ECU-1 Influent (VSP-1)	VOCs (TO-15 Modified)	Monthly	Monthly	Quarterly	NA
ECU-1 Effluent/ECU-2 Influent (VSP-2)	VOCs (TO-15 Modified)	As Needed	As Needed	As Needed	NA
ECU-2 Effluent/ECU-3 Influent (VSP-3)	VOCs (TO-15 Modified)	As Needed	As Needed	As Needed	NA
ECU-3 Effluent/ECU-4 Influent (VSP-4)	VOCs (TO-15 Modified)	As Needed	As Needed	As Needed	NA
Total Effluent (VSP-5)	VOCs (TO-15 Modified)	Monthly	Monthly	Quarterly	NA

Because we care  
100% recycled paper produced by wind power energy

Table 1. Treatment System Monitoring Program, Groundwater Interim Remedial Measure, Operable Unit 3 (Former Grumman Settling Ponds), Northrop Grumman Systems Corporation, Bethpage, New York. (1)

Sample Location/Instrument <sup>(1)</sup>	Parameter/Method <sup>(2)</sup>	Frequency			SCADA Data Acquisition
		Short-Term <sup>(3)</sup>		Long-Term <sup>(4)</sup>	
		(first month)	(five month period following first month)		
<b><u>Water Flow Measurements</u></b>					
Remedial Well RW-1 (FT - 110)	Flow rate (gpm + total gal.)	(Daily -1st week) Weekly	Weekly	Weekly	Continuously
Remedial Well RW-2 (FT - 120)	Flow rate (gpm + total gal.)	(Daily -1st week) Weekly	Weekly	Weekly	Continuously
Remedial Well RW-3 (FT - 130)	Flow rate (gpm + total gal.)	(Daily -1st week) Weekly	Weekly	Weekly	Continuously
Remedial Well RW-4 (FT - 140)	Flow rate (gpm + total gal.)	(Daily -1st week) Weekly	Weekly	Weekly	Continuously
Combined Influent (FR - 200)	Flow rate (gpm + total gal.)	(Daily -1st week) Weekly	Weekly	Weekly	Continuously
System Effluent (FT-700)	Flow rate (gpm + total gal.)	(Daily -1st week) Weekly	Weekly	Weekly	Continuously
<b><u>Air Flow Measurements</u></b>					
Air Stripper Effluent (FT-500)	Flow rate (SCFM)	(Daily -1st week) Weekly	Weekly	Weekly	Continuously
<b><u>Water Pressure Measurements</u></b>					
Remedial Well RW-1 (PT - 110)	Pressure (i.w.g.)	(Daily -1st week) Weekly	Weekly	Weekly	Continuously
Remedial Well RW-2 (PT - 120)	Pressure (i.w.g.)	(Daily -1st week) Weekly	Weekly	Weekly	Continuously
Remedial Well RW-3 (PT - 130)	Pressure (i.w.g.)	(Daily -1st week) Weekly	Weekly	Weekly	Continuously
Remedial Well RW-4 (PT - 140)	Pressure (i.w.g.)	(Daily -1st week) Weekly	Weekly	Weekly	Continuously
System Effluent (PT-700)	Pressure (i.w.g.)	(Daily -1st week) Weekly	Weekly	Weekly	Continuously
<b><u>Air Temperature &amp; Relatively Humidity Measurements</u></b>					
Air Stripper Effluent (TI-500)	Temperature	Weekly	Weekly	Weekly	Continuously
ECU Mid-Train (TI-501)	Temperature	Weekly	Weekly	Weekly	NA
Effluent (TI-601)	Temperature	Weekly	Weekly	Weekly	NA

Because we care  
100% recycled paper produced by wind power energy

Table 1. Treatment System Monitoring Program, Groundwater Interim Remedial Measure, Operable Unit 3 (Former Grumman Settling Ponds), Northrop Grumman Systems Corporation, Bethpage, New York. (1)

Sample Location/Instrument <sup>(1)</sup>	Parameter/Method <sup>(2)</sup>	Frequency			SCADA Data Acquisition
		Short-Term <sup>(3)</sup> (first month)	(five month period following first month)	Long-Term <sup>(4)</sup>	
<b><u>Air Pressure Measurements</u></b>					
Air Stripper Effluent (PT-500)	Pressure (i.w.g.)	(Daily -1st week) Weekly	Monthly	Quarterly	Continuously
ECU #1 Influent (PI-501)	Pressure (i.w.g.)	(Daily -1st week) Weekly	Monthly	Quarterly	NA
ECU #2 Influent (PI-502)	Pressure (i.w.g.)	(Daily -1st week) Weekly	Monthly	Quarterly	NA
ECU #3 Influent (PI-503)	Pressure (i.w.g.)	(Daily -1st week) Weekly	Monthly	Quarterly	NA
ECU #4 Influent (PI-504)	Pressure (i.w.g.)	(Daily -1st week) Weekly	Monthly	Quarterly	NA
System Effluent	Pressure (i.w.g.)	(Daily -1st week) Weekly	Monthly	Quarterly	NA

Notes:

- 1 Refer to Figure 2 for diagram showing referenced sample locations. Sampling locations labeled, instrumentation is shown but not labeled.
  - 2 Parameters/methods may be modified based on review of short-term and/or long-term testing results. Parameters shown in **Bold** indicate parameters that require NYSDEC notification/approval prior to change in monitoring schedule.
  - 3 Short-term schedule is tentative. Modification may be required/recommended based on the results of start-up and performance testing.
  - 4 Long-term schedule is tentative. Modification may be required/recommended based on the results of short-term testing or water quality trends.
  - 5 Water samples will be collected in accordance with the methods described in "Operable Unit 2 Groundwater Remedy, Operation, Maintenance, and Monitoring Plan, Northrop Grumman and NWIRP Sites, Bethpage, New York, Volume 1, dated 3 December 2002" and analyzed in accordance with the methods and procedures described in "Remedial Investigation/Feasibility Study Work Plan, Former Grumman Settling Ponds (Operable Unit 3 - Bethpage Community Park), Bethpage, New York, revised March 8, 2006" (OU3 RI/FS Workplan).
  - 6 Per NYSDEC request, a 1-hr pilot test will be performed during system shake-down. 1-hr pilot test samples will also be analyzed for mercury.
  - 7 Air samples will be collected and analyzed in accordance with methods described in "Operation, Maintenance, and Monitoring Manual, Soil Gas Interim Remedial Measure, Operable Unit 3 - Former Grumman Settling Ponds, Bethpage, New York, dated January 2009".  
Additional air samples will be collected to help calculate media usage rates and to help determine media changeout frequencies.
- NA Not applicable.  
 ECU Emissions control unit.  
 VOCs Volatile organic compounds (TCL VOCs, including Freon 12 and Freon 22, assuming the appropriate laboratory standard is available at the time of the analysis).  
 gal. Gallons.  
 gpm Gallons per minute.  
 i.w.g. Inches water gauge  
 NYSDEC New York State Department of Environmental Conservation.  
 EPA U.S. Environmental Protection Agency.  
 TCL Target Compound List  
 SCADA Supervisory Control And Data Acquisition

Because we care

100% recycled paper produced by wind power energy

Table 2. Groundwater Monitoring Program, Groundwater Interim Remedial Measure, Operable Unit 3 (Former Grumman Settling Ponds), Northrop Grumman Systems Corporation, Bethpage, New York. (1,2)

Well ID	Well Diameter (inches)	Depth to Screen		Screen Length (ft)	Well Depth (ft)	Well Materials	Water Levels <sup>(3)</sup>	MONITORING ACTIVITY		
		Top (ft bls)	Bottom (ft bls)					VOC	WATER QUALITY <sup>(4)</sup> Cd/Cr/Hg	Fe/Mn
<b>Monitoring Wells</b>										
BCPMW-1	2	50	65	15	65	Sch. 40 PVC	Quarterly	Baseline	Baseline	--
BCPMW-2	2	60	75	15	75	Sch. 40 PVC	Quarterly	Baseline	Baseline	Baseline
BCPMW-3	2	59	74	15	74	Sch. 40 PVC	Quarterly	Baseline	Baseline	Baseline
BCPMW-4-1	4	45	65	20	70	Sch. 40 PVC	Quarterly	Baseline/Semiannual <sup>(5)</sup>	Baseline/Annual	Baseline
BCPMW-4-2	4	68.5	83.5	15	88.5	Sch. 40 PVC	Quarterly	Baseline/Semiannual <sup>(5)</sup>	Baseline/Annual	Baseline
BCPMW-4-3	4	115	125	10	130	Sch. 40 PVC	Quarterly	Baseline/Semiannual <sup>(5)</sup>	Baseline/Annual	Baseline
BCPMW-5-1	4	50	65	15	70	Sch. 80 PVC/ SS	Quarterly	Baseline	Baseline	Baseline
BCPMW-6-1	4	88.5	98.5	10	103.5	Sch. 40 PVC	Quarterly	Baseline/Semiannual <sup>(5)</sup>	Baseline/Annual	--
BCPMW-6-2	4	133	143	10	148	Sch. 40 PVC	Quarterly	Baseline/Semiannual <sup>(5)</sup>	Baseline/Annual	--
BCPMW-7-1	4	90	100	10	105	Sch. 40 PVC	Quarterly	Baseline/Semiannual <sup>(5)</sup>	Baseline/Ann	--
B24MW-2	2	54	74	20	74	PVC	Quarterly	Baseline/Annual	Baseline	--
B24MW-3	2	55	70	15	70	PVC	Quarterly	Baseline/Annual	Baseline	--
B30MW-1	2	57	72	15	72	PVC	Quarterly	Baseline/Annual	Baseline	--
MW-200-1	4	85	95	10	100	Sch. 40 PVC/ SS	Quarterly	Baseline/Semiannual <sup>(5)</sup>	Baseline/Annual	--
MW-201-1	4	70	80	10	85	Sch. 40 PVC/ SS	Quarterly	Baseline/Semiannual <sup>(5)</sup>	Baseline/Annual	--
MW-202-1	4	125	135	10	140	Sch. 40 PVC/ SS	Quarterly	Baseline/Semiannual <sup>(5)</sup>	Baseline/Annual	--
MW-203-1	4	103	113	10	118	Sch. 40 PVC/ SS	Quarterly	Baseline/Semiannual <sup>(5)</sup>	Baseline/Annual	--
<b>Remedial Wells <sup>(6)</sup></b>										
RW-01	8	108	128	20	134	Sch. 80 PVC/SS	Quarterly	Baseline/Quarterly	Baseline/Quarterly	--
RW-02	6	84	104	20	104	Steel/SS	Quarterly	Baseline/Quarterly	Baseline/Quarterly	--
RW-03	8	84	104	20	107	Sch. 80 PVC/SS	Quarterly	Baseline/Quarterly	Baseline/Quarterly	--
RW-04	8	110	130	20	133	Sch. 80 PVC/SS	Quarterly	Baseline/Quarterly	Baseline/Quarterly	--

Because we care  
100% recycled paper produced by wind power energy



# ARCADIS

Table 2. Groundwater Monitoring Program, Groundwater Interim Remedial Measure, Operable Unit 3 (Former Grumman Settling Ponds), Northrop Grumman Systems Corporation, Bethpage, New York. (1,2)

Well ID	Well Diameter (inches)	Depth to Screen		Screen Length (ft)	Well Depth (ft)	Well Materials	Water Levels <sup>(3)</sup>	MONITORING ACTIVITY		
		Top (ft bls)	Bottom (ft bls)					VOC	WATER QUALITY <sup>(4)</sup> Cd/Cr/Hg	Fe/Mn
<b>Piezometers</b>										
PZ-01a	2	60	65	5	68	Sch. 40 PVC	Quarterly	--	--	--
PZ-01b	1	80	85	5	88	Sch. 40 PVC	Quarterly	--	--	--
PZ-01c	1	130	135	5	138	Sch. 40 PVC	Quarterly	--	--	--
PZ-02a	2	60	65	5	68	Sch. 40 PVC	Quarterly	--	--	--
PZ-02b	1	80	85	5	85	Sch. 40 PVC	Quarterly	--	--	--
PZ-02c	1	130	135	5	138	Sch. 40 PVC	Quarterly	--	--	--
PZ-03	1	80	85	5	88	Sch. 40 PVC	Quarterly	--	--	--
PZ-04	1	80	85	5	88	Sch. 40 PVC	Quarterly	--	--	--
PZ-05a	2	65	70	5	74	Sch. 40 PVC	Quarterly	--	--	--
PZ-05b	1	110	115	5	117	Sch. 40 PVC	Quarterly	--	--	--
PZ-06a	2	65	70	5	72	Sch. 40 PVC	Quarterly	--	--	--
PZ-06b	1	90	95	5	97	Sch. 40 PVC	Quarterly	--	--	--
PZ-07a	2	65	70	5	72	Sch. 40 PVC	Quarterly	--	--	--
PZ-07b	1	113	118	5	120	Sch. 40 PVC	Quarterly	--	--	--

**Notes and Abbreviations**

- Water samples will be collected and analyzed in accordance with the method and procedures described in "Remedial Investigation/Feasibility Study Work Plan, Former Grumman Settling Ponds (Operable Unit 3 - Bethpage Community Park), Bethpage, New York, revised March 8, 2006" (OU3 RI/FS Workplan).
- Approximate locations of the wells and piezometers in the OU3 Groundwater IRM Monitoring Program are shown in Figure 1.
- Water Levels will be measured in all wells/piezometers during the baseline monitoring event. Water levels will be measured in accordance with the procedures presented in the Field Sampling Plan in the OU3 RI/FS Workplan.
- VOC: TCL VOCs using NYSDEC ASP 2000 Method OLM 4.2. with Freon 12 and 22  
Cd/Cr: Cadmium and Chromium using USEPA Method ILM 4.0, both total and dissolved; Hg: Mercury will only be analyzed for samples collected during the baseline monitoring.  
Fe/Mn: Iron and Manganese using USEPA Method ILM 4.0, both total and dissolved
- Semiannual wells will be monitored annually after Year 1.
- Some of the analyses listed here are also covered in the System Sampling Program presented in the Operation, Maintenance, and Monitoring Plan.

Sch. 80 PVC: schedule 80 polyvinyl chloride

Sch. 40 PVC: schedule 40 polyvinyl chloride

SS: stainless steel

Steel: low carbon steel

ft: feet

ft msl: feet relative to mean sea level

ft bls: feet below land surface

TCL: Target Compound List

Because we care

100% recycled paper produced by wind power energy

CITY (Revised) DIVISION (Revised) DBI (Revised) LD (Revised) PK (Revised) TR (Revised) LYR (Revised) OFF (Revised) REF (Revised) REV (Revised) DATE (Revised) BY (Revised) PROJECT (Revised) SHEET (Revised) OF (Revised) TOTAL SHEETS (Revised)  
 C:\Users\jdoyle\OneDrive\Documents\Projects\OU-3 Groundwater Monitoring Program\OU-3 Groundwater Monitoring Program.dwg  
 11/15/2024 10:58:00 AM  
 PROJECT: OU-3 GROUNDWATER MONITORING PROGRAM  
 SHEET: GWMON-1

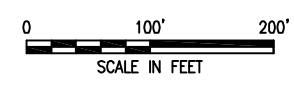
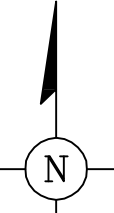
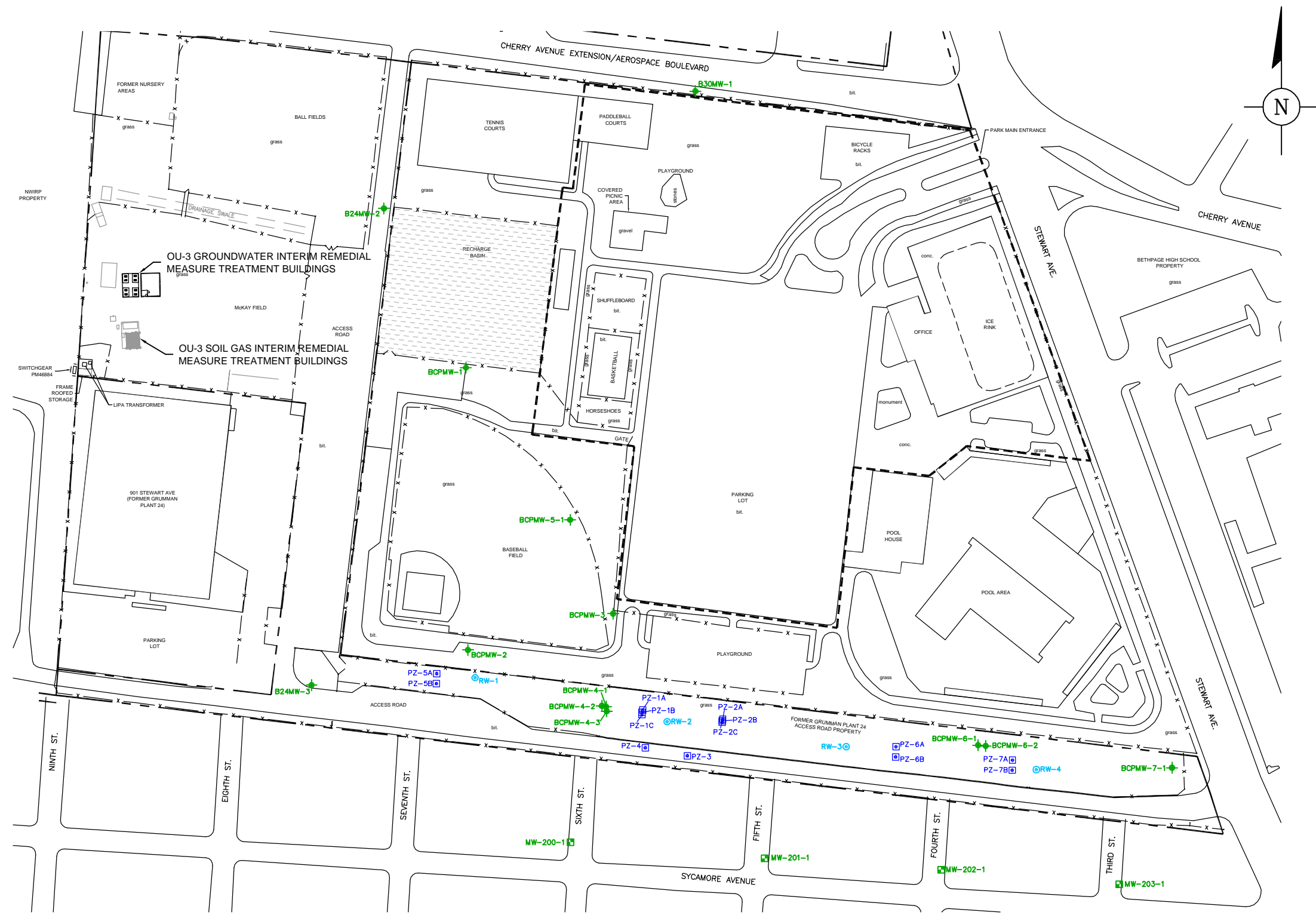

- LEGEND:**
- NORTHROP GRUMMAN PROPERTY LINE
  - FENCE
  - BASIN
  - bit. BITUMINOUS PAVEMENT
  - ◆ BCPMW-1 MONITORING WELL
  - MW-200-1 MONITORING WELL
  - PZ-2C PIEZOMETER
  - RW-2 RECOVERY WELL

- NOTES:**
1. MONITORING WELLS, BCPMW-1, 2, 3, 4-1, 4-2, 4-3, 5-1, 6-1, 6-2, 7-1, B24MW-2, B24MW-3, B30MW-1 SURVEYED TO NORTH AMERICAN DATUM (NAD) 83. ALL OTHER MONITORING WELLS, RECOVERY WELLS, AND PIEZOMETERS ARE APPROXIMATE BASED ON FIELD MEASUREMENTS.
  2. PARK FEATURES SHOWN WERE PRESENT PRIOR TO TOWN OF OYSTER BAY REDEVELOPMENT IN 2005.

OU-3 GROUNDWATER INTERIM REMEDIAL MEASURE  
NORTHROP GRUMMAN SYSTEMS CORPORATION  
BETHPAGE, NEW YORK

**GROUNDWATER MONITORING PROGRAM  
WELL AND PIEZOMETER NETWORK**

FIGURE  
**1**

CITY: (Reqd) DIV: (Reqd) DB: (Reqd) LD: (Opt) PIC: (Opt) PM: (Reqd) TM: (Opt) Lyr: (Opt) ON: OFF=REF. 6/5/2009 2:10 PM BY: SANCHEZ, ADRIAN  
 G:\ENVCAD\Melville-NY\01491\000\00012\startup\workplan\Process Flow Diagram.dwg LAYOUT: 2SAVED: 6/5/2009 1:37 PM ACADVER: 17.1.5 (LMS TECH) PAGESETUP: .....PLOTSTYLETABLE: ARCADIS\_MELVILLE.CTB PLOTTED: 6/5/2009 2:10 PM BY: SANCHEZ, ADRIAN  
 XREFS: IMAGES: PROJECTNAME: NY01491.000.00012

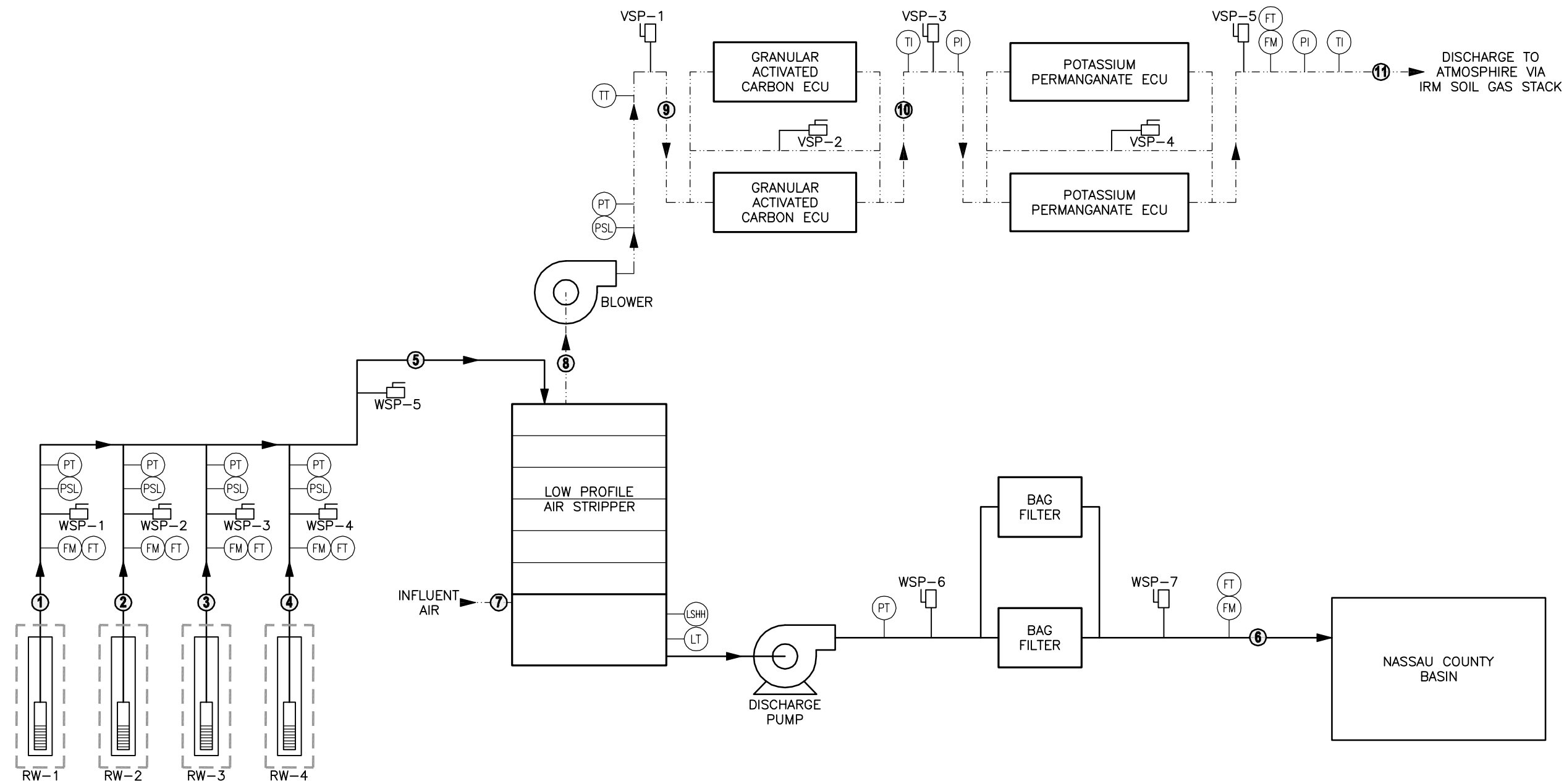

- LEGEND:**
- PROCESS WATER
  - - - PROCESS AIR
  - (FM) INSTRUMENT
  - SAMPLE PORT
  - ▶ FLOW DIRECTION
  - FM FLOW METER
  - FT FLOW RATE TRANSMITTER
  - PSL PRESSURE VACUUM LOW
  - PT PRESSURE TRANSMITTER
  - PI PRESSURE INDICATOR
  - LSHH LEVEL SWITCH HIGH HIGH
  - LT LEVEL TRANSMITTER
  - TT TEMPERATURE TRANSMITTER
  - TI TEMPERATURE INDICATOR
  - ⑧ PROCESS DESIGNATION
  - WSP WATER SAMPLE PORT
  - VSP VAPOR SAMPLE PORT

PROCESS	①	②	③	④	⑤	⑥	⑦	⑧	⑨	⑩	⑪
<b>Mass Loading (lbs/day)</b>											
Trichloroethene	0.009	0.041	0.082	0.008	0.140	<0.008	0.000	0.140	0.140	<0.014	<0.014
cis -1,2 Dichloroethene	0.007	1.877	0.431	0.030	2.346	<0.008	0.000	2.346	2.346	<0.235	<0.235
Vinyl Chloride	0.000	0.443	0.001	0.000	0.444	<0.003	0.000	0.444	0.444	<0.444	<0.044
<b>Flow Rate (gpm)</b>	40	85	85	40	250	250	---	---	---	---	---
<b>Flow Rate (CFM)</b>	---	---	---	---	---	---	1,300 - 1,600	1,300	1,535	1,557	1,581
<b>Pressure (feet of water)</b>	10	10	10	10	8	15	---	---	---	---	---
<b>Pressure (inches of water)</b>	---	---	---	---	---	---	0	- 28 to - 38	12	6	0
<b>pH</b>	6.4	6.4	6.4	6.4	6.4	6.2	---	---	---	---	---
<b>Temperature</b>	55	55	55	55	55	55	10	55	97	95	95
<b>Relative Humidity</b>	---	---	---	---	---	---	20 - 80	100	<50	<50	<50

OU-3 GROUNDWATER INTERIM REMEDIAL MEASURE  
 NORTHROP GRUMMAN SYSTEMS CORPORATION  
 BETHPAGE, NEW YORK

SAMPLING AND MONITORING  
 LOCATIONS

**FIGURE**  
**2**