

Feasibility Study/Corrective Measures Study

**Site 4 (Area of Concern [AOC] 22) – Former
Underground Storage Tanks**

**Naval Weapons Industrial Reserve Plant
Bethpage, New York**



**Mid-Atlantic Division
Naval Facilities Engineering Command**

**Contract Number Contract No. N62470-08-D-1001
Contract Task Order WE62**

June 2013



FEASIBILITY STUDY/CORRECTIVE MEASURES STUDY

SITE 4 (AREA OF CONCERN [AOC] 22) – FORMER UNDERGROUND STORAGE TANKS

**NAVAL WEAPONS INDUSTRIAL RESERVE PLANT
BETHPAGE, NEW YORK**

**Submitted to:
Naval Facilities Engineering Command Mid-Atlantic
9742 Maryland Avenue
Norfolk, Virginia 23511-3095**

**Submitted by:
Tetra Tech, Inc.
234 Mall Boulevard Suite 260
King of Prussia, Pennsylvania 19406**

In Support Of:

**N62470-08-D-1001
Contract Task Order WE62**

June 2013

PREPARED UNDER THE DIRECTION OF:



**DAVID BRAYACK, P.E.
PROJECT MANAGER
TETRA TECH, INC.
NORFOLK, VIRGINIA**

APPROVED FOR SUBMISSION BY:

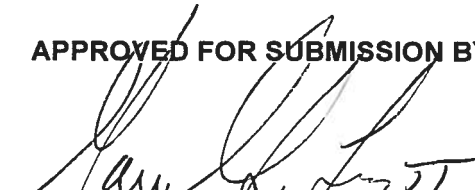

**JOHN TREPANOWSKI, P.E.
PROGRAM MANAGER
TETRA TECH, INC.
KING OF PRUSSIA, PENNSYLVANIA**

TABLE OF CONTENTS

<u>SECTION</u>	<u>PAGE</u>
TABLE OF CONTENTS	iii
ACRONYMS AND ABBREVIATIONS	vi
1.0 INTRODUCTION	1-1
1.1 REGULATORY BACKGROUND	1-1
1.2 OBJECTIVES AND APPROACH	1-3
1.3 REPORT ORGANIZATION	1-5
2.0 SITE BACKGROUND	2-1
2.1 FACILITY INFORMATION	2-1
2.2 GEOLOGY	2-1
2.3 HYDROGEOLOGY	2-3
2.4 ENVIRONMENTAL INVESTIGATION HISTORY	2-4
2.5 NATURE AND EXTENT OF CONTAMINATION	2-8
2.6 SUMMARY OF RISK	2-10
3.0 REMEDIAL ACTION OBJECTIVES	3-1
3.1 NCP REQUIREMENTS	3-1
3.2 APPLICABLE OR RELEVANT AND APPROPRIATE REQUIREMENTS (ARARs).....	3-1
3.3 REMEDIAL ACTION OBJECTIVES (RAOs)	3-3
3.4 PERFORMANCE CRITERIA	3-4
3.5 PRELIMINARY REMEDIATION GOAL (PRG) ATTAINMENT	3-4
4.0 IDENTIFICATION AND SCREENING OF TECHNOLOGIES	4-1
4.1 GENERAL RESPONSE ACTIONS (GRAs).....	4-1
4.2 DETAILED SCREENING OF SOIL TECHNOLOGIES AND PROCESS OPTIONS	4-1
4.2.1 No Action.....	4-2
4.2.2 Institutional Controls.....	4-3
4.2.3 Removal	4-5
4.2.4 Disposal/Reuse	4-7
4.2.5 In-Situ Treatment	4-8
4.3 SELECTION OF REPRESENTATIVE PROCESS OPTIONS FOR SOILS.....	4-10
4.4 SUSTAINABILITY	4-11
5.0 DEVELOPMENT AND EVALUATION OF REMEDIAL ALTERNATIVES	5-1
5.1 EVALUATION CRITERIA	5-1
5.2 DEVELOPMENT AND EVALUATION OF REMEDIAL ALTERNATIVES FOR SOILS.....	5-3
5.2.1 Alternative 1—No Action	5-4
5.2.2 Alternative 2—Monitored Natural Attenuation and Land Use Controls	5-5
5.2.3 Alternative 3 – Steam Injection and Free Product Recovery	5-8
5.2.4 Alternative 4 – Biosparging with Steam Injection and Free Product Recovery	5-11
5.2.5 Alternative 5 – Solvent Extraction and Free Product Recovery with Biosparging	5-15
5.2.6 Alternative 6 – Excavation and Disposal of Soils (Alternative 6A greater than 1,000 mg/Kg TPH and Alternative 6B greater than 10,000 mg/Kg).....	5-19
5.3 COMPARATIVE ANALYSIS OF ALTERNATIVES	5-21
5.3.1 Overall Protection of Human Health and the Environment	5-22
5.3.2 Compliance with ARARs	5-22
5.3.3 Long-term Effectiveness and Permanence	5-23
5.3.4 Reduction of Toxicity, Mobility, or Volume through Treatment	5-23
5.3.5 Short-term Effectiveness.....	5-24
5.3.6 Implementability	5-24

5.3.7	Cost.....	5-25
5.3.8	Media Cleanup Standards	5-25
5.3.9	Source Control	5-25
5.3.10	Waste Management Standards	5-25
5.4	LIFE-CYCLE ANALYSIS AND OPTIMIZATION	5-26
5.4.1	Objective	5-26
5.4.2	Sustainability Evaluation Policy Background	5-26
5.4.3	Evaluation Tools.....	5-27
5.4.4	Environmental Footprint Evaluation Framework and Limitations	5-28
5.4.5	Evaluation Results	5-28
5.4.6	Energy Consumption.....	5-32
5.4.7	Water Usage	5-32
5.4.8	Accident Risk - Fatality	5-33
5.4.9	Conclusions and Recommendations	5-34

REFERENCES.....	R-1
------------------------	------------

APPENDICES

A	ANALYTICAL RESULTS FREE PRODUCT SAMPLE
B	2011/2012 SITE 4 BENCHSCALE TREATABILITY STUDY TEST RESULTS
C	CALCULATIONS
D	COST ESTIMATES

TABLES

(presented at the end of the document)

NUMBER

2-1	Analytical Detections in Site Soils
2-2	Analytical Detections in Site Groundwater
2-3	Maximum Detection Summary of Site Groundwater Samples
2-4	Maximum Detection Summary of Site Soil Samples
2-5	Chemicals of Potential Concern (COPC) for Site Groundwater and Soil
3-1	Chemical-Specific Applicable or Relevant and Appropriate Requirements (ARARs)
3-2	Location-Specific Applicable or Relevant and Appropriate Requirements (ARARs)
3-3	Action-Specific Applicable or Relevant and Appropriate Requirements (ARARs)
3-4	Preliminary Remediation Goals for Site Soil
3-5	Preliminary Remediation Goals for Site Groundwater
4-1	General Response Actions for Soil
4-2	Screening of Technologies and Process Options for Soils
4-3	Summary of Technologies and Process Options Retained for Development and Evaluation
5-3	Comparative Analysis of Alternatives
5-4	Summary of Costs

FIGURES

(presented at the end of the document)

NUMBER

1-1	General Location Map, NWIRP Bethpage
1-2	Site Location Map, AOC 22/Site 4
2-1	Site 4 Layout, AOC 22 (Former USTs)
2-2	Areal Extent of Contamination, Site 4
2-3	Vertical Extent of Contamination, Cross Section A-A', Site 4
2-4	Vertical Extent of Contamination, Cross Section B-B', Site 4
2-5	Conceptual Site Model, AOC 22/Site 4
2-6	Conceptual Site Model Exposure Pathways
5-1A	Alternative 3: Steam Injection and Free Product Recovery Conceptual Layout
5-1B	Alternative 3: Steam Injection and Free Product Recovery Conceptual Cross Section
5-1C	Steam Injection and Free Product Recovery, Process Diagram
5-2A	Alternative 4: Biosparging with Steam Injection and Free Product Recovery, Conceptual Layout
5-2B	Alternative 4: Biosparging with Steam Injection and Free Product Recovery
5-2C	Alternative 4, Biosparging with Steam Injection and Free Product Recovery, Process Diagram
5-3A	Alternative 5: Solvent Extraction and Free Product Recovery, with Biosparging, Conceptual Layout
5-3B	Alternative 5: Solvent Extraction and Free Product Recovery, with Biosparging, Conceptual Cross Section View
5-3C	Alternative 5, Solvent Extraction and Free Product Recovery, with Biosparging, Process Diagram
5-4A	Alternatives 6A and 6B: Excavation Conceptual Layout
5-4B	Alternative 6A and 6B: Excavation Conceptual Cross Section View
5-4C	Alternative 6A, Excavation, Process Diagram
5-4D	Alternative 6B, Excavation, Process Diagram

ACRONYMS AND ABBREVIATIONS

µg/L	microgram per liter
AOC	Area of Concern
ARAR	Applicable or Relevant and Appropriate Requirement
AS	air sparge
bgs	below ground surface
BTUs	British Thermal Units
CERCLA	Comprehensive Environmental Response, Compensation, and Liability Act
CFM	cubic feet per minute
CH ₄	methane
CLB	Closed-Loop Bioreactor
CLEAN	Comprehensive Long-Term Environmental Action Navy
CMI	Corrective Measures Implementation
CMS	Corrective Measures Study
CO ₂	carbon dioxide
CO ₂ e	carbon dioxide equivalents
COPC	Chemical of Potential Concern
CSM	Conceptual Site Model
CTO	Contract Task Order
DOD	Department of Defense
DON	Department of Navy
DRO	Diesel Range Organics
EISB	Enhanced In Situ Bioremediation
EPA	United States Environmental Protection Agency
ERP	Environmental Restoration Program
°F	Fahrenheit
FFS	Focused Feasibility Study
FS	Feasibility Study
GAC	granulated activated carbon
GHG	greenhouse gas
GOCO	Government-owned Contractor-operated
GRA	general response action
GRO	Gasoline Range Organics
HP	horsepower
HRS	Hazard Ranking System
IAS	Initial Assessment Study
IDW	investigation-derived waste
Kh	hydraulic conductivity
KW	Kilowatt
LTM	long term monitoring
LUCs	Land Use Controls
MCL	Maximum Contaminant Level
mg/Kg	milligrams per Kilogram
MNA	monitored natural attenuation
msl	mean sea level

ACRONYMS AND ABBREVIATIONS (Continued)

NAVFAC	Naval Facilities Engineering Command
NCP	National Contingency Plan
NGC	Northrop Grumman Corporation
NO _x	nitrogen oxides
N ₂ O	nitrous oxide
NTCRA	non-time critical removal action
NWIRP	Naval Weapons Industrial Reserve Plant
NYSDEC	New York State Department of Environmental Conservation
NYSDOH	New York State Department of Health
O&M	operation and maintenance
OSHA	Occupational Safety and Health Act
PA	Preliminary Assessment
PAHs	polynuclear aromatic hydrocarbons
PCBs	polychlorinated biphenyls
PM ₁₀	particulate matter
PP	Proposed Plan
PPE	personal protective equipment
PRG	Preliminary Remedial Goals
PV	present value
PVC	polyvinyl chloride
RA-C	remedial action construction
RAO	Remedial Action Objectives
RA-O	remedial action operation
RCRA	Resource Conservation and Recovery Act
RFA	RCRA Facility Assessment
RFI	RCRA Facility Investigation
RI	Remedial Investigation
ROD	Record of Decision
RSL	Regional Screening Level
SARA	Superfund Amendments and Reauthorization Act
SI	Site Investigation
SO _x	sulfur oxides
SSL	Soil Screening Level
STARS	Spill Technology and Remediation Series
SVE	soil vapor extraction
SVOC	semi-volatile organic compound
TAL	Target Analyte List
TAGM	Technical and Administrative Guidance Memorandum
TBC	to be considered
TCRA	time critical removal action
TPH	total petroleum hydrocarbons
TSD	Treatment, Storage, or Disposal
USACE	United States Army Corps of Engineers
UIC	Underground Injection Control

ACRONYMS AND ABBREVIATIONS (Continued)

UST	Underground storage tank
Vertec	VertecBio Gold #4
VOC	volatile organic compound

1.0 INTRODUCTION

This Feasibility Study (FS)/Corrective Measures Study (CMS) for Site 4 (Area of Concern [AOC] 22) – Former Underground Storage Tank (UST) Area at Naval Weapons Industrial Reserve Plant (NWIRP) Bethpage, New York (Figures 1-1, 1-2) was prepared by Tetra Tech Inc. for Naval Facilities Engineering Command (NAVFAC) – Mid-Atlantic under the U.S. Navy's Comprehensive Long-Term Environmental Action (CLEAN) Contract No. N62470-08-D-1001, Contract Task Order (CTO) WE62.

Site 4 is on a 9-acre parcel being retained by the Navy to complete environmental investigation and remediation. Environmental concerns were first identified at Site 4 during a 1997 investigation by Northrop Grumman Corporation (NGC) that identified former USTs and petroleum-contaminated soil in the area. The USTs reportedly contained No. 6 Fuel Oil, and were removed between 1980 and 1984. Since then, petroleum-contaminated soil and semi-solid petroleum product have been identified above and below the water table (the groundwater table is present at approximately 50 feet below ground surface [bgs]). Clean soils have been confirmed at a depth of 73 feet bgs. Groundwater contains both fuel and chlorinated solvent contaminants.

NWIRP Bethpage was a government-owned, contractor-operated (GOCO) facility owned by Naval Air Systems Command and operated by NGC. Operations at NWIRP Bethpage ceased in 1998. This FS/CMS is being completed as part of the Navy's Environmental Restoration Program (ERP), which addresses historic releases at Navy facilities, and subsequent environmental remedial response activities as necessary.

1.1 REGULATORY BACKGROUND

When NWIRP Bethpage was operational, it was a large quantity generator of hazardous waste, and was classified as a Treatment, Storage, and Disposal (TSD) facility, for storage of hazardous wastes beyond 90 days. Due to this designation, NWIRP Bethpage was issued a permit under the Resource Conservation and Recovery Act (RCRA) [Environmental Protection Agency (EPA) ID NYD002047967] in which the Navy was identified as the property owner and Northrop Grumman was listed as the operator. The 9-acre parcel including Site 4 retains the RCRA permit, with requirements limited to corrective action.

NWIRP Bethpage is also classified as an "Inactive Hazardous Waste Disposal Site" under New York State Department of Environmental Conservation (NYSDEC) 6 NYCRR Part 375 (Registry No. 1-30-003B). The Part 375 program is a risk-based program and closely parallels the United States EPA Superfund Program.

Environmental investigations are also being conducted under the Comprehensive Environmental Response, Compensation, and Liability Act (CERCLA) of 1980. The Navy is lead federal agency under

the National Oil and Hazardous Substances Pollution Contingency Plan (NCP), 40 CFR Part 300, and Executive Order 12580, as amended by Executive Order 13016, for CERCLA response activities at NWIRP Bethpage. The stages for Navy's ERP site investigations and actions are managed under the RCRA¹ and CERCLA². A comparison of steps for each program is presented below (Navy, 2006).

CERCLA Response Actions and RCRA Corrective Actions at Federal Facilities	
CERCLA Response Action	RCRA Corrective Action
Preliminary Assessment/Site Inspection (PA/SI) <ul style="list-style-type: none"> • Preliminary Assessment (PA), formerly known as the Initial Assessment Study (IAS). • Hazard Ranking System (HRS) Scoring. • Site Inspection (SI). 	RCRA Facility Assessment (RFA) <ul style="list-style-type: none"> • Preliminary Review. • Visual Site Inspection. • Sampling Visit.
Removal Action <ul style="list-style-type: none"> • Emergency Removal Actions • Time-Critical Removal Actions (TCRAs) • Non-Time-Critical Removal Actions (NTCRAs) 	Interim Measures <ul style="list-style-type: none"> • Interim Remediation. • Temporary Fixes. • Alternate Water Supplies.
Remedial Investigation (RI) <ul style="list-style-type: none"> • Site-Specific Data Collection. • Source Characterization. • Contamination Characterization. • Waste Mixtures, Media Interface Zones. • Hydrogeological and Climate Factors. • Risk Assessment. • Potential Routes of Exposure. • Extent of Migration. 	RCRA Facility Investigation (RFI) <ul style="list-style-type: none"> • Background Data Review. • Environmental Setting Investigation. • Sources Characterization. • Contamination Characterization. • Potential Receptors Characterization.
Feasibility Study (FS) <ul style="list-style-type: none"> • Define Objectives and Nature of Response. • Develop Alternatives. • Conduct Detailed Analysis of Alternatives. 	Corrective Measures Study (CMS) <ul style="list-style-type: none"> • Identify and Develop Alternatives. • Evaluate Alternatives. • Justify & Recommend Corrective Measure.

¹ RCRA as amended by the Hazardous and Solid Waste Amendments of 1984, the Federal Facility Compliance Act of 1992, and the Land Disposal Program Flexibility Act of 1996. U.S. Code (USC) Title 42, Section 6901 (42 USC 6901) et seq. RCRA Subtitle C (Hazardous Waste Regulations; Code of Federal Regulations [CFR] Title 40, Parts 260 through 279 [40 CFR 260-279]) establishes a system for controlling hazardous waste from the time it is generated until its ultimate disposal (from "cradle to grave").

² CERCLA as amended by the Superfund Amendments and Reauthorization Act of 1986 and implemented by the National Oil and Hazardous Substances Pollution Contingency Plan (NCP). The NCP (40 CFR 300) was originally established to respond to oil spills. However, following issuance of the Clean Water Act of 1972 (CWA), the NCP was broadened to include actual and potential hazardous substance releases.

CERCLA Response Actions and RCRA Corrective Actions at Federal Facilities	
CERCLA Response Action	RCRA Corrective Action
Remedy Selection <ul style="list-style-type: none"> • Select Remedy Which Meets Nine NCP Criteria. • Proposed Plan (PP). • Record of Decision (ROD). 	Remedy Selection <ul style="list-style-type: none"> • Select Remedy that Abates Threat to Human Health and the Environment.
Remedial Design/Remedial Action <ul style="list-style-type: none"> • Design Remedy. • Perform Remedial Action. • Perform Operations and Maintenance and Monitoring. 	Corrective Measures Implementation (CMI) <ul style="list-style-type: none"> • Develop Implementation Plan, Program, and Community Relations Plan. • Corrective Measures Design. • Construction and Implementation.

* Removal Actions and Interim Measures may be implemented at any point during the Response Action or Corrective Action

Both CERCLA and RCRA share the goal of protecting human health and the environment, and any procedural differences between CERCLA and RCRA should not substantially affect the outcome of cleanup.

1.2 OBJECTIVES AND APPROACH

This document is developed to serve as an FS under CERCLA and CMS under RCRA in accordance with the above listed RCRA permit. Consistent with CERCLA and RCRA processes, this FS/CMS includes a comparative analysis of remedial alternatives that will support the selection of a preferred remedy. Subsequently, the Navy will work with the State to select a preferred remedy pursuant to RCRA and CERCLA, and will provide the public opportunity for comment on a RCRA Statement of Basis and CERCLA Proposed Plan (PP). After considering the public comments, the State will prepare the RCRA permit modification and the Navy will prepare its CERCLA Record of Decision (ROD).

The CMS uses the conceptual site model (CSM) generated during the RCRA Facility Investigation (RFI) and subsequent investigations to develop remedial action objectives (RAOs), preliminary remediation goals (PRGs), and an evaluation of remedial alternatives. A list of chemicals of potential concern (COPCs) for soils (Section 3.0) is based on exceedances of risk to human health and/or applicable federal and/or state criteria. This report discusses criteria used to evaluate remedial alternatives and to determine the benefits of implementing them.

Pursuant to the NCP and the 1988 EPA FS guidance, the remedial alternatives are evaluated according to their ability to meet the following nine NCP criteria:

Threshold Criteria:

1. Overall protection of human health and the environment
2. Compliance with Applicable or Relevant and Appropriate Requirements (ARARs)

Primary Balancing Criteria:

3. Long-term effectiveness and permanence
4. Reduction of toxicity, mobility, or volume through treatment
5. Short-term effectiveness
6. Implementability
7. Cost

Modifying Criteria:

8. State acceptance
9. Community acceptance

Under the RCRA CMS process, the remedial alternatives are evaluated according to their ability to meet the following criteria:

Performance Standards:

1. Attain media cleanup standards
2. Control the sources of releases
3. Protect human health and the environment

Balancing Factors:

1. Long-term reliability and effectiveness
2. Reduction of toxicity, mobility, or volume of wastes
3. Short-term effectiveness
4. Implementability
5. Cost
6. State and community acceptance

State and community acceptance are evaluated after regulatory and public comment on the FS/CMS. Sustainability elements (e.g., green remediation) may also be considered during evaluation of the remedial alternatives (refer to Sections 4 and 5). The information presented herein will be used by the Navy, as federal lead agency, in cooperation with State and local officials pursuant to CERCLA §120(f) and §121 (42 U.S.C. §9620(f) and §9621) and 10 U.S.C. §2705(f), to select remedial alternative(s) that

comply with the requirements of the NCP. This FS/CMS is not intended to serve as a design document; rather, it gives a conceptual overview of remedial alternatives and an assessment of their feasibility.

The Navy maintains a public repository, which includes supporting technical documents and correspondence related to the site and NWIRP Bethpage, at the following location:

Bethpage Public Library
47 Powell Avenue
Bethpage, NY 11714
(516)931-3907

A public web site with the Administrative Record can be accessed at the following web page.

<http://go.usa.gov/pvu>

1.3 REPORT ORGANIZATION

This report is organized as shown in the Table of Contents. Tables and figures are provided at the end of the document.

2.0 SITE BACKGROUND

This section provides a summary of background information for Site 4 – Former USTs (AOC 22), including previous environmental investigations and actions that occurred at the site. Additional information may be found in the various reports referenced in this section, which are available in the Administrative Record.

2.1 FACILITY INFORMATION

NWIRP Bethpage was established in 1943 and operated by Northrop Grumman Corporation until the late 1990s. The plant's primary mission was the research prototyping, testing, design engineering, fabrication, and primary assembly of military aircraft. The facilities at NWIRP Bethpage included four plants used for assembly and prototype testing; a group of quality control laboratories, two warehouse complexes (north and south), a salvage storage area, storm and non-contact cooling water recharge basins, the Industrial Wastewater Treatment Plant, and several smaller support buildings. In 1998, operations ended at the facilities.

Until the late 1990s, the NWIRP Bethpage was approximately 109.5 acres in size. In 2002, 4.5 acres of the property were transferred to Nassau County. On February 26, 2008, the Navy transferred an additional 96 acres of the remaining 105-acre main parcel to Nassau County, and leased the remaining 9 acres to Nassau County. Site 4 is on the remaining 9-acre parcel being retained by the Navy for environmental investigations and remediation. Upon the successful remediation of the 9-acre parcel, it will also be transferred to Nassau County. Current transfer and lease documents provide land use controls and notifications of areas in which residual contamination is still present.

The facility is located on Long Island, New York (Figure 1-1). It is located on a relatively flat, featureless, glacial outwash plain. The site and nearby vicinity are highly urbanized. Because of this, most of the natural physical features have been reshaped or destroyed. Elevations range from greater than 140 feet above mean sea level (msl) in the north to less than 110 feet above msl at the southwest corner. Site 4 is located south of Plant No. 3 between Plant No. 3 and Building 03-35 (Figure 2-1).

2.2 GEOLOGY

The Upper Glacial Formation (commonly referred to as glacial deposits) forms the surface deposits across the entire NWIRP. The glacial deposits beneath the site consist of coarse sands and gravels. These deposits are generally about 40 to 45 feet thick; local variations in thickness are common due to the irregular and undulating contact of the glacial deposits with the underlying Magothy Formation. The contact between the two formations was defined in the field as the horizon where gravel becomes very rare to absent, and finer sands, silts, and clays predominate. The generally coarse nature of both formations near their contact, however, may make this differentiation either difficult or rather subjective.

The results of the drilling program at monitoring well location HN-24 (near Site 4) and surrounding well locations appear to confirm the regional observation that there are no singular, extensive clay units beneath the NWIRP. Clay units encountered at any particular location do not persist along strike or in either direction of dip. The stratigraphic section at and below subsurface depths of about 100 feet may be considered "clay-prone" because the number of individual clay units significantly increases below this depth, but none of these clays are laterally persistent.

Most of the geological observations made during the Site 4 drilling program agree with earlier observations made concerning the nature of the contact and predominant lithologies present progressing downwards stratigraphically through the Upper Glacial Formation into the upper portions of the Magothy Formation. In all fourteen of the soil borings drilled in Site 4, boring log descriptions indicate that the entire sequence of sediments comprising the Upper Glacial Formation was penetrated. Evidence supporting this is based on the transition noticed from sediments consisting of mostly coarse sands with less common gravels. This transition was observed to take place in most of the soil borings between approximately 50 feet to 56 feet bgs. In TT22-SB06, TT22-SB08, and TT22-SB14, the three soil borings furthest to the east, gravels became less abundant at intervals ranging from approximately 39 feet to 49 feet bgs. On a local scale, it appears that the Upper Glacial Formation is slightly thicker in this area than earlier studies have indicated. This finding in combination with the general variation in thickness noted between soil borings progressing west to east across the study area, support the idea that the contact is likely undulating in nature.

The persistence of mostly medium to very coarse sands and occasional gravels over intervals greater than 50 feet bgs in all of the soil borings indicate the generally coarse nature of the transitional strata at the top of the upper Magothy Formation. The appearances of finer-grained sediments below this depth were more common. These sediments included silty to clayey sands, sand to silty clays, and clays. Sequences composed of finer-grained sediments generally ranged from micro laminations to thinly bedded with respect to bedding thickness. As in previous subsurface investigations, however, no observations supporting the existence of a singular, extensive confining clay unit beneath the NWIRP was made to the maximum depths of approximately 61 feet to 63 feet bgs sampled. It is likely that the presence of finer-grained sediments underlying Site 4 do contribute to the overall semi-confining conditions observed in monitoring wells installed in previous investigations that were screened over deeper intervals of the Magothy Formation. Of note is the observation of viscous free petroleum product in soil borings TT22-SB01 through TT22-SB04, which made it difficult to ascertain at times if sediment cohesiveness was a function of the presence of silts and clay fines or the 'sticky' nature of the free product.

2.3 HYDROGEOLOGY

The Upper Glacial Formation and the Magothy Formation comprises the aquifer of concern at the NWIRP. Regionally, these formations are generally considered to form a common, interconnected aquifer as the coarse nature of each unit near their contact and the lack of any regionally confining clay unit allow for the unrestricted flow of groundwater between the formations.

Although the water table beneath the NWIRP occurs below the glacial deposits, they are hydrogeologically important because their high permeability allows for the rapid recharge of precipitation to the underlying Magothy Formation. In addition, the large quantities of groundwater withdrawn daily from the Magothy pass back through part of the glacial deposits via the recharge basins to the Magothy Formation.

The Magothy aquifer is the major source of public water in Nassau County. The most productive water bearing zones are the discontinuous lenses of sand and gravel that occur within the generally siltier matrix. The major water-bearing zone is gravel commonly found in the basal Magothy.

The Magothy aquifer is commonly regarded to function overall as the unconfined aquifer at shallow depths and a confined aquifer at deeper depths. The drilling program on the NWIRP has revealed that clay zones beneath the facility are common but laterally discontinuous. No confining clay units of facility wide extent were encountered.

Hydraulic characteristics beneath Site 4 were investigated by conducting rising head slug tests in three of the five constructed permanent groundwater monitoring wells in order to obtain site-specific values. Hydraulic head data were evaluated using the Hyorsely Method and revealed similar horizontal hydraulic conductivity values (K_h) for TT22-MW03, TT22-MW04, and TT22-MW05 of 2.64×10^{-2} centimeters per second (cm/sec), 1.12×10^{-2} cm/sec, and 2.02×10^{-2} cm/sec, respectively. These values are consistent with formational materials comprised predominantly of well-sorted sands and glacial outwash (Fetter, C.W., 1994). Past investigations and estimated values for the horizontal hydraulic conductivity for the portion of the Magothy Formation underlying the NWIRP have ranged between 50 to 100 feet per day. In comparison, the average horizontal hydraulic conductivity determined using slug test data for the upper portion of the Magothy Formation underlying Site 4 falls within this range at 55 feet per day.

Water level data were gathered from each of the permanent groundwater monitoring wells to determine the preferred direction of shallow groundwater flow underlying Site 4. These data revealed the dominant direction of shallow groundwater flow towards the south and southwest. This is in agreement with shallow groundwater flow orientation determination made during previous investigations at the NWIRP. During the course of this most recent investigation, it was also noted that the static groundwater levels for the newly constructed permanent groundwater monitoring wells changed on the order of one to two feet,

likely as a result of the combination of minimal precipitation/recharge in conjunction with regional aquifer demands.

2.4 ENVIRONMENTAL INVESTIGATION HISTORY

Environmental concerns for this area are based on a Northrop Grumman investigation of UST's near Plant No. 3 (Figure 2-1). The USTs were reportedly removed sometime between 1980 and 1984.

In 1997, Northrop Grumman conducted a soil investigation at the former UST location (Site 4). During this investigation soil borings were installed around and under the former tanks. Approximately 144 soil samples were collected in eight areas from depths of 8 to 65 feet bgs. This depth range represents soils collected from the bottom of the former USTs to the approximate water table, at that time. The samples were analyzed for total petroleum hydrocarbons (TPHs), petroleum based volatile organic compounds (VOCs), and semi-volatile organic compounds (SVOCs). Sample concentrations were compared to the NYSDEC Spill Technology and Remediation Series (STARS) Memorandum No. 1 – Petroleum-Contaminated Soil Guidance Policy (August 1992) (NYSDEC, 1992). STARS Memorandum Guidance Values have since been replaced by other relevant screening criteria. Table 2-1 contains a summary of analytical detections in site soils.

VOCs were detected infrequently in the soil samples, and none of the 1997 detected results exceeded STARS Memorandum Guidance Values (Table 2 of the Guidance). SVOCs were detected more frequently. Approximately 23 percent of the 1997 soil samples exceeded one or more STARS Memorandum SVOC parameters for PAHs. Exceedances of STARS Memorandum Guidance Values were noted in all of the soil boring locations including most sample depths from shallow soils (8 feet bgs) to deeper soils near the water table. However, the maximum SVOC concentration detected that exceeded a STARS Memorandum criteria was only 4.3 milligrams per kilogram (mg/kg), indicating that although petroleum hydrocarbons were wide spread, concentrations were relatively low.

TPH testing was conducted to evaluate potential fuel oil contamination. This testing found petroleum in soils at concentrations up to 18,000 mg/kg and at depths near the water table. The petroleum hydrocarbons were of the Diesel Range Organics (DRO) that are consistent with No. 4 and No. 6 fuel oils reported at this location (RCRA Facility Assessment/Focused Feasibility Study [Tetra Tech NUS, 2003]). See Table 2-1 for a summary of results from TPH testing of soils.

In August 1999, Tetra Tech NUS conducted soil and groundwater investigations in association with a RCRA Facility Assessment (Tetra Tech NUS, 2003). The purpose of the investigation was to further characterize the horizontal extent of contamination in subsurface soils, to determine if groundwater had been impacted, to determine if free product was present, and to characterize the free product for recovery and disposal purposes.

Five permanent monitoring wells were installed during the 1999 investigation (Figure 2-2). Two of the wells (MW01 and MW02) were installed at close proximity to the presumed source area in soil borings that showed evidence of free product. Two monitoring wells (MW03 and MW04) were installed at the perimeter of the AOC where limited free product was evident. One monitoring well (MW05) was installed inside Plant No. 3 in order to determine if free product or groundwater contamination existed beneath the plant.

Evidence of free product was observed in MW01 and MW02 at a maximum thickness of 0.02 feet (1/4 inch). Because of the limited volume of free product, two composite samples of free product were collected and analyzed for VOCs, SVOCs, and polychlorinated biphenyls (PCBs), pesticides, RCRA metals, flash point, British Thermal Units (BTUs), and chloride. Analytical results for the free product sample had no detections of VOCs, SVOCs, PCBs, or pesticides. Detections in site groundwater are summarized in Table 2-2.

As part of the 1999 investigation, soil samples were collected for TPH-DRO and TPH-GRO (Gasoline Range Organics) analysis. Three samples were analyzed for VOCs and SVOCs. Based on field observations during this investigation, petroleum-contaminated soils were observed from 20 feet bgs to the water table (approximately 50 feet bgs) within 5 to 10 feet of the former USTs foot print. At a distance of approximately 10 to 40 feet from the former UST area, petroleum-contaminated soils were only observed at the water table. At distances greater than 60 feet, there was no evidence of petroleum-contaminated soils (see Table 2-1).

Results from the 1999 investigation concluded that there was no VOC contamination in the soil. The SVOCs detected were PAHs, constituents of TPH-DRO. The results were compared to NYSDEC Technical and Administrative Guidance Memorandum (TAGM) 4046 criteria. The only SVOC which exceeded TAGM criteria at the time was chrysene. TAGM Criteria have since been replaced by NYSDEC Soil Cleanup Objectives. TPH-DRO and TPH-GRO contamination was present in samples collected in close proximity to the former UST area (see Table 2-1). Samples taken from a distance of 60 feet or more from the former UST area displayed no contamination, therefore it was determined that there was limited horizontal extent of soil contamination. In groundwater, chlorinated VOCs were present in upgradient wells MW03 and MW05, which indicated that the presence of these chemicals may be from a source further up gradient. Wells MW01 and MW02, down gradient of the former USTs, contained the highest concentrations of aromatic VOCs and PAHs. Concentrations of benzene, ethylbenzene, xylenes, and naphthalene were detected in excess of the NYSDEC groundwater criteria (see Table 2-2). It was concluded that the absence of these chemicals in the upgradient wells indicates that the fuel product from the source area may have impacted groundwater; however, based on the concentrations, the impact was minor (see Table 2-2). Results from the free product analyses indicated the product was characteristic of weathered heavy fuel oils and was not classified as hazardous (see Appendix A).

In 2003, a Focused Feasibility Study (FFS) was prepared that evaluated several alternatives including capping (cover) with deed restrictions, groundwater monitoring, excavation/off-site disposal, and in-situ treatment options of bioremediation, chemical oxidation, and thermally enhanced soil vapor extraction. Due to the depth of soil contamination, the recommended alternative was a cap with deed restrictions on subsurface excavation and groundwater monitoring to evaluate potential site impacts on groundwater. Residual petroleum at the site would be slowly addressed through natural processes, including biodegradation. Capping and deed restrictions would be used to prevent direct human exposure to deep soil contamination and restrict future use of site groundwater. Groundwater monitoring would evaluate the natural breakdown of the petroleum and potential effects on groundwater. Based on comments from NYSDEC, this alternative was not pursued.

In 2004, the Navy proceeded with a pilot-scale in-situ bioremediation study at the site. A Closed-Loop Bioreactor (CLB) pilot-scale system study was conducted by a vendor using an innovative technology that combined in-situ and ex-situ bioremediation, Fentons reagent, and soil washing. The CLB system featured no discharge of soil vapors and adds pure oxygen to promote biodegradation. Six additional groundwater monitoring wells were installed (MW06 to MW11, Figure 2-2).

In the summer of 2004, the remedy of a CLB pilot-scale study was implemented on site (Tetra Tech NUS, 2007). The CLB system vendor combined vapor extraction and air sparging (AS), vacuum enhanced product recovery, desorption of hydrocarbons from soil particles, and enhanced biodegradation via surfactant injection. The in-situ CLB System was located in the vadose and saturated soil zone. To create a closed-loop system, the extracted soil vapor was treated and then re-injected into the formation. Baseline soil and groundwater samples were collected before the system was initiated. To monitor the progress of the remedial program, soil and groundwater samples were periodically collected as the CLB system was operating. The system was shut down in the spring of 2006.

Subsurface soils and groundwater samples were collected for chemical analysis between August 2004 and August 2005 by Tetra Tech NUS and the CLB System vendor. Soil samples in August 2004 represent pre-CLB system operation (see Table 2-1). At that time, average TPH concentrations in the 20- to 50-foot interval ranged from 4,599 mg/kg to 6,645 mg/kg and the average TPH concentration in the 60-foot interval was 21,320 mg/kg. This data was consistent with previous test data that indicated the majority of the petroleum contamination was located near the water table. The overall average TPH concentration was 8,819 mg/kg and represents the baseline TPH concentration for evaluating the effectiveness of the CLB System pilot-scale study.

Tetra Tech NUS conducted a post-CLB system operation sampling event in September 2006. Samples collected were generally consistent with the data collected by the CLB System vendor between August 2004 and August 2005. TPH concentrations in the 20-, 30- and 40-foot intervals decreased over time,

with reductions ranging from 76 percent in the 30-foot interval to 19 percent in the 50-foot interval. However, the TPH concentration in the 60-foot interval increased by 28 percent, suggesting that one effect of the CLB pilot-study was to cause the petroleum contamination to migrate downward. The only significant differences between the August 2005 and September 2006 data were that the average TPH concentration in the 60-foot interval decreased to 16,190 mg/kg and the average TPH concentration in the 50-foot interval increased to 12,250 mg/kg (see Table 2-1). The overall average TPH concentration in December 2006 was 7,353 mg/kg (a 16.6 percent reduction).

In December 2006, because of the observed trend of the petroleum migrating downward, Tetra Tech NUS also collected soil samples at a depth of approximately 70 feet bgs, which is approximately 18 feet below the water table. TPH results in this interval ranged from 37.5 mg/kg to 5,100 mg/kg, indicating low to moderate levels of TPH at this depth.

Groundwater samples were collected by Tetra Tech before, during, and after the CLB System pilot-scale study to evaluate potential migration from treatment. A complete round of 11 monitoring wells (MW01 to MW11) were sampled prior to the pilot-scale study (September 2004) and 9 monitoring wells were sampled during and after the pilot-scale study was completed (December 2006). Because of the presence of a free floating product or a semi-solid tar-like free product in monitoring wells MW01 and MW02 after the start of the CLB test, MW01 and MW02 were not sampled in later sampling events. In addition, two rounds of six monitoring wells (MW06 to MW11) were sampled during the operation of the pilot-scale study, (March and October 2005). In summary, the groundwater result, with the exception of monitoring wells MW01 and MW02, there were no obvious impacts to groundwater from operation of the pilot-scale system (see Table 2-2).

In November 2010, four soil borings were installed to complete the vertical delineation of petroleum-contaminated soil and to obtain soil for a Bench Scale Treatability Study. Contamination was detected between 20 and 71 feet bgs, but clean soils were also confirmed at approximately 73 feet below ground surface (see Table 2-1).

In 2010 and 2011, bench scale treatability studies were performed to characterize the nature of petroleum product near the water table, and determine if the residual petroleum material exists as a free product, is adsorbed onto soil, and/or is immobile. The study also evaluated the feasibility of using thermal and solvent-based extraction to allow recovery of the petroleum product above and below the water table, and the ability to biodegrade solvent-based extraction residues using circulated air via biosparging. Soil column studies were conducted to simulate the effect of heating the product in-situ, using solvents such as diesel and a soybean-based solvent (VertecBio Gold #4[Vertec]) to facilitate recovery of product in-situ. The studies found that when soils were submersed in water, some of the product was released from the soil and floated to the water surface. When heated, additional product was released, and higher

temperatures were observed to produce the most floating product. Heating soils to a temperature of 120 to 140 degrees Fahrenheit (°F) did not produce explosive conditions. Based on visual observation of the color of the treated soil, both solvents released product from soils, with the Vertec releasing more product. The bench scale study was successful in demonstrating that the product can be desorbed from the soil when heated, or rinsed with either diesel or Vertec. Results can be found in the Technical Memorandum for Site 4 Bench Scale Studies (Appendix B).

Groundwater samples were collected in March 2011 from nine existing monitoring wells (MW03 to MW11, Figure 2-2). A round of free product/water levels were collected prior to sampling activities. Results from this event characterize the current condition of groundwater quality at Site 4 (see Table 2-2).

2.5 NATURE AND EXTENT OF CONTAMINATION

TPH-DRO and TPH-GRO, and PAHs have been detected in site soils. The maximum detection of TPH was 50,000 mg/Kg (maximum detection in SB102 at 61 feet bgs). NYSDEC has not established TPH concentration-based criteria, but does regulate VOC and SVOC constituents associated with TPH and has established cleanup goals for these constituents. In addition, NYSDEC requires treatment (removal) of TPH that forms a free product. Monitoring wells MW01 and MW02 contained a thick tar-like material that is approximately 0.02 feet (1/4 inch). During operation of the CLB, floating free product formed on the water table and was removed as it was generated.

Groundwater: Groundwater samples contained VOCs, SVOCs, and total metals. An analytical detection summary for site groundwater is provided in Table 2-2. New York State Department of Health (NYSDOH) maximum contaminant limits (MCLs) and EPA Regional Screening Levels (RSLs) are included in the table for comparison purposes. Chlorinated VOCs are in site groundwater, but may be from sources. Some metals (especially iron) were detected in groundwater during the operation of the CLB system. However, metal concentrations have dropped since the shutdown of the CLB system. Target Analyte List (TAL) metals were not sampled prior to implementation of the CLB system, so a baseline level of metals in groundwater cannot be determined. Metals that exceeded either NYSDOH MCLs or EPA RSLs included arsenic, cadmium, cobalt, iron, manganese, and thallium. Based on the 2011 sampling event data, cadmium (12.2 µg/L in MW11), cobalt (49.5 µg/L in MW06), iron (8,880 µg/L in MW06), and manganese (2,570 µg/L in MW06) exceed MCLs and are COPCs. In 1999, naphthalene (20 µg/L in MW01 and MW02) and pentachlorophenol (8.5 µg/L in MW06) are the only SVOCs currently exceeding either EPA RSLs or NYSDOH MCLs in groundwater and are COPCs. VOCs in groundwater that are COPCs consist of the petroleum constituents benzene (17 µg/L in MW01), ethylbenzene (18 µg/L in MW01), and xylenes (7.6 µg/L in MW01). The groundwater contamination indicates that residual free product (as documented in wells MW01 and MW02) may be acting as a continuing source and remedial actions will address this concern. Except for pentachlorophenol in one downgradient well (MW06), there

is no evidence of migration of these organics beyond the source area. An analytical detection summary for site groundwater is provided in Table 2-2. A summary of the maximum detections in site groundwater is provided in Table 2-3.

Subsurface Soil: SVOCs that have been identified as COPCs (and maximum concentration) for soils are polynuclear aromatic hydrocarbons (PAHs) and consist of 2-methylnaphthalene (73,000 µg/Kg), acenaphthene (6,400 µg/Kg), benz(a)anthracene (4,200 µg/Kg), benzo(a)pyrene (2,700 µg/Kg), benzo(b)fluoranthene (3,300 µg/Kg), bis(2-ethylhexyl)phthalate (320 J µg/Kg), chrysene (8,600 µg/Kg), fluorene (25,000 J µg/Kg), indeno(1,2,3-cd)pyrene, (200 J µg/Kg) naphthalene (15,000 J µg/Kg), and pyrene (36,000 µg/Kg). Each of these COPCs are all present at concentrations greater than NYSDEC Unrestricted Use Soil Cleanup Objectives, NYSDEC Soil Cleanup Objectives for the Protection of Groundwater, and/or EPA RSLs and Soil Screening Levels (SSLs). The reported detections for site soils are provided in Table 2-1 and the maximum detections are summarized in Table 2-4.

Conceptual Site Model (CSM) and Contaminant Fate and Transport

A CSM conveys what is known or suspected about contamination sources, release mechanisms, and the transport and fate of those contaminants. It provides the basis for understanding contaminant fate and transport issues and assessing potential remedial technologies at the site. The CSM for Site 4 is derived from available data and accepted principles of contaminant fate and transport. The areal extent of contamination and locations of cross sections are provided in Figure 2-2. Figures 2-3 (Cross Section A-A') and 2-4 (Cross Section B-B') show the vertical extent of contamination through interpretive cross sections of the subsurface soils and the distribution of TPH contamination. The estimated areal extent of contamination is approximately 0.14 acres. Figure 2-5 shows a three-dimensional CSM interpretation of the site and Figure 2-6 provides potential human health exposure routes.

The COPCs for groundwater include VOCs, SVOCs, and metals (Table 2-5). If ingested, groundwater poses a potential risk as an exposure route in the human health risk scenario. Chlorinated VOCs are in groundwater from other source areas, and are being addressed through implementation of the OU-2 Groundwater ROD.

Based on the results of investigations and chemical and physical data, the source of fuel contamination is the USTs that reportedly contained No. 6 fuel oil. Petroleum-contaminated and semi-solid petroleum products are present near and below the groundwater table at a depth range of 20 to 71 feet bgs. After the conclusion of the CLB pilot-study in 2006, TPH concentrations in the 20-, 30- and 40-foot intervals decreased, with reductions ranging from 76 percent in the 30-foot interval to 19 percent in the 50-foot interval. However, the TPH concentration in the 60-foot interval increased by 28 percent, suggesting that one effect of the CLB pilot-study was to cause the petroleum to migrate downward.

The COPCs for soils consist of PAHs, see Table 2-5. The primary risk pathways at this site are through potential direct contact to PAH-contaminated soils, and contaminant migration from soil to groundwater followed by potential ingestion of contaminated groundwater. Because the petroleum-contaminated soils are encountered at depths below 20 feet bgs, it is unlikely that there would be human exposure through direct contact with contaminated soils and groundwater is not currently used as a potable water supply. However, soils could be excavated and used elsewhere that would allow direct contact with site contaminants and groundwater could be used as a drinking water supply in the future. Although unlikely, if the deep soils were excavated below 20 feet, site workers could be exposed to contaminated soil.

2.6 SUMMARY OF RISK

A qualitative risk assessment was conducted for Site 4 using both risk-based groundwater and soil quality values. Table 2-3 provides a comparison of maximum detected concentrations in Site 4 groundwater to NYSDOH MCLs and EPA RSLs for the protection of groundwater. SVOCs with concentrations exceeding MCLs are considered COPCs for evaluation in this FS/CMS, with groundwater posing an unacceptable risk for residential exposure to groundwater through ingestion and dermal contact.

Table 2-4 provides a comparison of maximum detected concentrations in Site 4 subsurface soils to EPA RSLs, EPA SSLs, NYSDEC Unrestricted Use Soil Cleanup Objectives, and NYSDEC Cleanup Objectives for the Protection of Groundwater. Chemicals with concentrations exceeding criteria are considered COPCs for evaluation in this FS/CMS. COPCs in soils consist of PAHs that are associated with TPH. There are no relevant criteria associated with TPH contamination, however free product recovery (the source of PAHs) would also remove the PAHs. There are no associated risks with surface soils. Contaminated soils begin at approximately 20 feet bgs.

Since the site has been developed for commercial industrial use, there are no noted risks to ecological receptors.

3.0 REMEDIAL ACTION OBJECTIVES

This section describes the initial steps to develop alternatives for the remediation of soils at Site 4, including the presentation of ARARs and the development of RAOs.

3.1 NCP REQUIREMENTS

The NCP requires that the selected remedy meet the following objectives:

- Each remedial action selected shall be protective of human health and the environment.
- Onsite remedial actions that are selected must attain those ARARs that are identified at the time of the ROD signature.
- Each remedial action selected shall be cost-effective, provided that it first satisfies the threshold criteria above. A remedy shall be cost-effective if its costs are proportional to its overall effectiveness.
- Each remedial action shall use permanent solutions and alternative treatment technologies or resource-recovery technology to the maximum extent practicable.

The statutory scope of CERCLA was amended by Superfund Amendments and Reauthorization Act (SARA) to include the following general objectives for remedial actions at all CERCLA sites:

- Remedial actions "...shall attain a degree of cleanup of hazardous substances, pollutants, and contaminants released into the environment and of control of further releases at a minimum which assures protection of human health and the environment".
- Remedial actions "...in which treatment that permanently and significantly reduces the volume, toxicity, or mobility of the hazardous substances, pollutants, and contaminants is a principal element" are preferred. If the treatment or recovery technologies selected are not a permanent solution, an explanation must be published.
- The least-favored remedial actions are those that include "off-site transport and disposal of hazardous substances or contaminated materials without treatment where practicable treatment technologies are available".
- The selected remedy must comply with or attain the level of any "standard, requirement, criteria, or limitation under any federal environmental law or any promulgated standard, requirement, criteria, or limitation under a state environmental or facility siting law that is more stringent than any Federal standard, requirement, criteria, or limitation".

3.2 APPLICABLE OR RELEVANT AND APPROPRIATE REQUIREMENTS (ARARS)

As required by Section 121 of CERCLA, remedial actions carried out under Section 104 or secured under Section 106 by the President must attain the levels of standards of control for hazardous substances,

pollutants, or contaminants specified by the ARARs of federal and state environmental laws and state facility siting laws, unless waivers are obtained. Only promulgated federal and state laws and regulations can be considered ARARs. If the ARARs are neither applicable nor relevant and appropriate, the federal lead agency's remedial actions may be based on the "to be considered" (TBC) criteria or guidelines. These distinctions are critical to understanding how the federal lead agency integrates environmental requirements from other federal and state laws into its cleanup decision. The definitions of ARARs and TBCs below are from the NCP (40CFR 300.5).

- Applicable requirements are those cleanup standards, standards of control, and other substantive environmental protection requirements, criteria, or limitations promulgated under federal or state law that specifically address a hazardous substance, pollutant, contaminant, remedial action, location, or other circumstance at a CERCLA site.
- Relevant and appropriate requirements are those cleanup standards, standards of control, and other substantive environmental protection requirements, criteria, or limitations promulgated under federal or state law that, while not "applicable," address problems or situations sufficiently similar (relevant) to those encountered at a CERCLA site, that their use is well-suited (appropriate) to the particular site.
- TBC information are non-promulgated criteria, advisories, guidance, and proposed standards that have been issued by the federal or state government that are not legally binding and do not have the status of potential ARARs. However, the TBC information may be useful for developing an interim remedial action or for determining the necessary level of cleanup for the protection of human health and/or the environment. Examples of TBC information include USEPA Drinking Water Health Advisories, Reference Doses, and Cancer Slope Factors.

Another factor in determining which response or remedial requirements must be met is whether the requirement is substantive or administrative. CERCLA response actions must meet substantive requirements but not administrative requirements. Substantive requirements are those dealing directly with actions or with conditions in the environment. Administrative requirements implement the substantive requirements by prescribing procedures such as fees, permitting, and inspection that make substantive requirements effective. This distinction applies to onsite actions only.

Chemical-Specific ARARs

Chemical-specific ARARs set health-based concentration limits or discharge limits in various environmental media for specific hazardous substances, pollutants, or contaminants. Chemical-specific ARARs and TBCs for Site 4 are presented in Table 3-1. The chemical-specific ARARs and TBCs are used to establish preliminary remediation goals and consist of EPA and NYSDOH MCLs, NYSDEC Subpart 375 Soil Cleanup Objectives, and EPA RSLs.

Location-Specific ARARs

Location-specific ARARs are design requirements or activity restrictions that are based on the geographical position of a site. Location-specific ARARs for Site 4 are presented in Table 3-2. The primary location-specific ARAR at Site 4 is the groundwater classification for site groundwater as class GA, or a water source for potable water.

Action-Specific ARARs

Action-specific ARARs set performance, design, or other standards for particular activities in managing hazardous substances or pollutants. Potential action-specific ARARs for Site 4 are identified in Table 3-3. Action-specific ARARs can vary based on the type of technology used. Action-specific ARARs will likely apply to the handling, storage, and treatment of Investigation-Derived Waste (IDW), removal of free product, and contaminated soil, vapors, and groundwater, and injection of fluids into the groundwater.

3.3 REMEDIAL ACTION OBJECTIVES (RAOS)

The RAOs are statements that define the extent to which sites require cleanup to protect human health and the environment and comply with ARARs. The RAOs reflect the COPCs, exposure routes and receptors, and acceptable chemical concentrations (or range of acceptable chemical concentrations) for soils at Site 4. Contaminated soils represent a potential threat to human health and the environment (i.e., groundwater). The RAOs for Site 4 are as follows:

- Prevent human exposure (ingestion, dermal contact, dust inhalation) to soil contaminated at concentrations greater than PRGs.
- Prevent leaching of contaminants that would result in groundwater concentrations exceeding PRGs.
- Comply with chemical-specific, location-specific, and action-specific ARAR's and Guidance.

3.4 PERFORMANCE CRITERIA

Performance criteria are established in this section for purposes of evaluating remedial alternatives and for use in the conceptual design and cost estimates. Performance criteria provide a basis for further delineating the extent and volume of impacted media that require remediation and provide the design performance of the remedial alternatives. The performance criteria described here represent the levels of performance necessary to meet the RAOs. They also provide benchmarks for achieving compliance with ARARs (or when applicable, complying with ARAR waiver criteria).

A monitoring program capable of demonstrating conformance with the performance criteria (as described below and will be finalized in the ROD) would be an element of each remedial alternative.

Soils

As identified in Table 3-4, the COPCs for soils are limited to ten PAHs that represent a potential direct contact risk and/or can leach and adversely impact groundwater quality. These PAHs are associated with residual petroleum product at the site. The selected PRGs are presented in Table 3-4 and consider EPA RSL risk-based values and NYSDEC Unrestricted Use/Cleanup Objectives protective of groundwater. Although individual PAHs can result in excess risk to human health through direct contact, protection of groundwater quality represents the most stringent of the exposure pathways.

Groundwater

As presented in Table 3-5, the performance criteria or PRGs for groundwater will be equal to the New York State MCLs for VOCs, pentachlorophenol, and cadmium. For iron and manganese, the performance criteria will be based on the EPA RSLs. The NYSDOH MCLs for iron and manganese are secondary criteria and not directly linked to risk. In addition, these metals are suspected to be present in the groundwater because of anaerobic degradation of petroleum products and the presence of naturally occurring iron and manganese in soils. Remedial alternatives that reduce or eliminate residual petroleum will mitigate an ongoing release of iron and manganese. For cobalt and naphthalene, the performance criteria will be based on the EPA RSL.

3.5 PRELIMINARY REMEDIATION GOAL (PRG) ATTAINMENT

Current site conditions are described in Section 2.5. This section narrows the description of contamination to those media and areas that will be addressed by the remedial alternatives to achieve RAOs and comply with ARARs.

The Attainment Area is defined as the area over which RAOs, and therefore the PRGs, are to be met for soils and groundwater. For soil, PRG exceedances are limited to those soils containing greater than

1,000 mg/kg of TPH. In addition, the higher PAH concentrations (and PRG exceedances) correspond to those soils containing greater than 10,000 mg/kg TPH. Therefore, for remedial purposes, TPH will be used as a surrogate for evaluating compliance with PAH PRGs. In addition, reducing TPH concentrations in soil would reduce the organic load to groundwater, and therefore allow metals to precipitate. As shown in Figure 2-2, the Attainment Areas are approximately 0.14 acres for soil with greater than 1,000 mg/kg TPH and 0.08 acres for soil with greater than 10,000 mg/Kg TPH. These areas of contamination correspond to locations in which there were detections of both soil and groundwater COPCs. Although contamination is known to be stratified in this area (see Figures 2-3 and 2-4), the Attainment Area applies to the entire depth of contamination (20 to 71 feet bgs). The estimated volume of contaminated soil is approximately 6,800 cubic yards and contain 47 tons of TPH (TPH greater than 1,000 mg/kg). There are approximately 1,300 cubic yards and approximately 30 tons of petroleum in contaminated soils with more than 10,000 mg/kg of TPH, (see Appendix C for mass calculations).

The extent of groundwater contamination is co-located with the 1,000 mg/kg TPH isoconcentration contour (0.14 acres). The vertical extent of groundwater contamination is limited to the water table and is conservatively assumed to be limited to the maximum depth of TPH contamination (71 feet bgs).

4.0 IDENTIFICATION AND SCREENING OF TECHNOLOGIES

This section provides the identification of General Response Actions (GRAs) and the initial identification and screening of potential technologies.

4.1 GENERAL RESPONSE ACTIONS (GRAS)

The GRAs describe the broad range of actions that will satisfy the RAOs at the site. The GRAs for soils may include no action, institutional controls, containment, removal and disposal of contaminated soils, ex-situ treatment, and in-situ treatment. Consideration of the No Action scenario is required by CERCLA. The objective of this phase of the FS/CMS is to develop an appropriate range of remedial technologies and process options that will be used to develop remedial alternatives. Remedial alternatives will then be composed using general response actions singly or in combination to meet the RAOs. The primary contaminated medium of concern at this site is soils, with possible leaching of contamination to groundwater due to a remaining free product source.

The following GRAs will be evaluated:

- No Action
- Limited Action (i.e. Institutional Controls)
- Containment
- Removal
- Disposal
- Ex-Situ Treatment
- In-Situ Treatment

The technology screening evaluation is performed in this section, with representative process options selected for each GRA. The selection of technologies and process options for initial screening is based on the "Guidance for Conducting Remedial Investigations/Feasibility Studies under CERCLA" (EPA, 1988). A preliminary screening is conducted to focus on relevant technologies and process options to treat the COPCs in the relevant media of the site. Table 4-1 lists the GRAs for soils and identifies the approach that the GRA uses to achieve the RAOs.

4.2 DETAILED SCREENING OF SOIL TECHNOLOGIES AND PROCESS OPTIONS

Representative process options are selected based on a screening of effectiveness, implementability, and cost of a given technology. The following are descriptions of these evaluation criteria:

- Effectiveness
 - Protection of human health and the environment; reduction in toxicity, mobility, or volume; and permanence of the solution.
 - Ability of the technology to address the estimated areas or volumes of contaminated medium.
 - Ability of the technology to attain the PRGs required to meet the RAOs.
 - Technical reliability (innovative versus well-proven) with respect to contaminants and site conditions.
- Implementability
 - Overall technical feasibility at the site.
 - Availability of vendors, storage and disposal services, etc.
 - Administrative feasibility.
 - Special long-term maintenance and operation requirements.
- Cost (Qualitative)
 - Capital cost.
 - Operation and Maintenance (O&M) costs.

Note that because of limited groundwater contamination and its association with TPH, stand-alone groundwater remediation alternatives will not be developed. Instead, the effects of each soil remediation alternative on groundwater will be considered in the description of soil alternatives. Groundwater monitoring may be a component of several alternatives in this consideration. Table 4-2 identifies potentially applicable technologies and process options for addressing contaminated soils at Site 4. Table 4-2 also presents a preliminary screening of technologies to eliminate those that are clearly not viable for this Site. Several technologies were excluded from further consideration because of impracticality, site conditions, or COPC characteristics. The technologies that were retained are described below.

4.2.1 No Action

No action consists of maintaining the status quo at the site. As required under CERCLA regulations, the No Action alternative is carried through the FS to provide a baseline for comparison of alternatives and their effectiveness in mitigating risks posed by site contaminants. No remedial actions are taken under this alternative, and there are no costs associated with this alternative. There is no reduction in risk through exposure control or treatment. No action would not effectively evaluate contaminant mobility and potential migration off site since no monitoring would be performed.

Effectiveness

No action would not be effective in meeting the RAOs. Contaminated soil can be excavated and used elsewhere and there would be no barriers or other restrictions to exposure. The RAO to prevent the leaching of contaminants would not be met because free product would remain at the site and continue to impact groundwater and residual PAH concentrations would be greater than NYSDEC Soil Cleanup Objectives. No action would not be effective in evaluating either contaminant reduction through natural attenuation or possible contaminant migration off site in groundwater because no monitoring would be performed.

Implementability

No Action would be implementable.

Cost

There are no costs associated with no action.

Conclusion

No Action is retained to provide a baseline comparison.

4.2.2 Institutional Controls

Land Use Controls (LUCs)

Administrative restrictions would be included through deed notifications to restrict the site from being used for residential purposes, prevent the installation of public water supply wells, or other actions to restrict use of contaminated soil and/or groundwater and future site activities. Deed restrictions would remain in place while contamination remains.

Effectiveness

Prohibiting future development or otherwise restricting site use would minimize the occurrence of unacceptable risks from direct exposure to human receptors with contaminated soil or groundwater. Controls could also limit exposure through industrial activities.

Implementability

LUCs would be readily implementable. As part of a change of site to private ownership, provisions would be incorporated in property transfer documents to ensure that LUCs remain in place. Resources are readily available for administrative restrictions.

Cost

Costs of LUCs would be low.

Conclusion

Deed restrictions will remain in place while contamination remains. LUCs may be combined with other remedial technologies.

Monitoring

Sampling and analysis of soil and groundwater throughout the area of contamination would be used to evaluate whether natural attenuation mechanisms would result in the biodegradation of contaminants, or to evaluate if contaminant migration is occurring from the soil to the groundwater.

Effectiveness

Monitoring alone would not reduce the toxicity, mobility, or volume of contaminants in the soil, but rather determine potential reductions in contaminant concentrations through treatment or attenuation.

Implementability

A sampling and analysis program could be readily implemented.

Cost

Capital and O&M costs would be low to moderate, depending on the period of monitoring.

Conclusion

Monitoring is retained in combination with other process options for the development of remedial alternatives.

4.2.3 Removal

Solids removal

Excavation can be performed by a variety of equipment. The type of equipment that is selected must take into consideration several factors, such as the type of material to be removed, the load-bearing capacity of the ground surrounding the removal area, the depth and areal extent of removal, the required rate of removal, and the elevation of the groundwater table. Specialized excavation equipment is required for deeper excavations.

Logistics of the excavation must take into account the available space for operating the equipment, loading and unloading to transport the removed material, location of the site, etc. To maintain the stability of the sidewalls, shoring the walls would be required. Once excavation is completed, the location would be filled and graded with clean fill material, treated soils, or soils that can be reused in the excavation.

Effectiveness

Excavation is a well-proven and effective method of removing contaminated material from a site. Properly designed excavation would remove most or all of the contaminated soil in a relatively short time.

Sampling is typically required to verify the effectiveness of the removal action. Soil samples would be collected from the sidewalls and from the bottom of the excavation to determine when clean soils are reached. These samples would be analyzed for COCs to ensure that the remaining soil is not contaminated at unacceptable levels.

Implementability

The contaminated soils found at the site would be amenable to excavation; however, implementation would be difficult due to the depth of contamination (up to 71 feet bgs) and the need to excavate soils approximately 20 feet below the water table. Existing structures in the vicinity of the excavation would need to be stabilized, removed, or re-located. Because of the depth of the excavation, a significant shoring structure must be designed and installed. Site-specific health and safety procedures and Occupational Safety and Health Act (OSHA) regulations would have to be complied with to ensure that the exposure of workers to COPCs is minimized. This would include the wearing of personal protective equipment (PPE) and the implementation of dust-suppression measures. The excavation depth extends below the water table, and removal of saturated soil will be difficult.

Cost

Cost of excavation would be significant due to the depth of contamination.

Conclusion

Although the costs and technical issues for a complete excavation would be significant, excavation is retained for the development of remedial alternatives for evaluation as achieving an Unrestricted Use/Unlimited Exposure scenario in a relatively short period.

Free Product Recovery

Free product recovery is required for alternatives in which contamination is reduced through methods other than excavation. Several methods of free product recovery were investigated (see Table 4-2), but because of the viscous nature of the material and temperature requirements, bioslurping was chosen as a representative process option for free product recovery. Free product removal is accomplished through bioslurping by combining thermal technologies (steam injection to decrease viscosity of the free product) and vacuum-enhanced recovery systems to extract product from the capillary fringe and the water table. Bioslurping is a three-phase removal process in which air, water, and free product are removed from the subsurface through vacuum extraction.

Effectiveness

Bioslurping would effectively remove quantities of free product, while reducing the amount of groundwater that would need to be extracted with the product. This technology can be used at sites with deep water tables (i.e. greater than 30 feet bgs). By removing free flowing free product, concentrations of TPH at the site would be reduced, along with subsequent soil contamination. Remaining risks to human receptors would be mitigated because free product would not remain to possibly leach contaminants to groundwater. Concentrations of PAHs at the site would be reduced through treatment.

Implementability

This technology can be implemented in conjunction with in-situ thermal treatments to remove the free flowing free product that is created. Due to the three-phase nature of bioslurping, groundwater and air would also be extracted with free product. Air and groundwater that is removed via the bioslurping system may need to be treated prior to off-gas or disposal. Vendors for this technology are available, despite the complexity of the system. Operators with significant training would be required to run a bioslurping system.

Cost

Costs associated with this technology are moderate, depending on the duration of O&M activities and the requirement of additional off-gas and water treatment.

Conclusion

Bioslurping will be retained as a representative process option for free product removal in the development of alternatives.

4.2.4 Disposal/Reuse

Disposal/Soil Reuse

Based on the presence of contamination, excavated soils will be disposed off-site or used to backfill the excavation. Off-site landfilling consists of transporting the excavated soil to an off-site treatment, storage, and disposal (TSD) facility. Wastes are expected to be non-hazardous, and may be disposed in a RCRA Subtitle D (solid waste) landfill or reused (e.g., asphalt plant).

Effectiveness

This technology can be an effective disposal or reuse option for contaminated soil. Off-site landfills are permitted because they meet specific requirements of design and operation, which ensures the effectiveness of these facilities. Soils that do not contain contamination may be used as backfill, but would be sampled prior to being used as fill material to ensure that residual contamination does not remain or perpetuate continuing risks to receptors.

Implementability

Landfilling or reuse would be easily implementable. Facilities and services are readily available. Disposal in a landfill may require the removal of free liquids, therefore water from saturated soils would need to be removed. A waste profile would have to be prepared, which include contaminant concentrations and their leachability. If soils are used as backfill, they would need to be tested prior to their use to ensure contamination does not remain.

Cost

Cost of landfilling would be moderate. If soils can be used as backfill, this would reduce costs.

Conclusion

Landfilling and beneficial reuse is retained in combination with other process options for the development of remedial alternatives.

Beneficial Reuse

Waste oils recovered (i.e. TPH as free product) can be reused for asphalt plants or as fuel.

Effectiveness

Reuse of waste oils is easily implementable, as manufacturers can use oils for a variety of applications. Reuse would reduce the amount of oil that would need to be disposed in a facility.

Implementability

Beneficial reuse would be implemented with process options that actively remove free product. Reuse is easily implementable.

Cost

Reuse would reduce waste disposal costs.

Conclusion

Beneficial reuse is retained in combination with other process options for the development of alternatives.

4.2.5 In-Situ Treatment

Thermal – Steam Injection

Steam is injected into the subsurface to heat contaminants and reduce its viscosity to allow free product to form on the water table. A network of steam injection wells would be used to heat subsurface soils.

Effectiveness

Steam injection is proven effective specifically for sites heavily contaminated with petroleum (high concentrations). Steam injection may not be effective on soils containing lower concentrations of TPH (e.g., less than 1,000 mg/kg TPH). The process is effective on deep contaminated soil, including soil with contamination extending above and below the water table. Steam would reduce the viscosity of the petroleum and the injection would agitate the bound petroleum, and in combination would mobilize contaminants and allow a free product layer to form on the water table. The free product would then have to be removed. The 2010 and 2011 bench scale treatability studies found that when soils were heated, a portion of the fuel product formed a free-flowing material which floated on the water surface. Higher temperatures released greater amounts of free product.

Implementability

Vendors and equipment to implement steam injection is available.

Cost

Costs are expected to be moderate, and are largely associated with the number of wells required, the amount of energy required to heat site soils, and the rate in which the viscous tar like substance can be transformed to a free floating product. Deeper contamination requires higher operating pressures, thus increasing costs. Free product removal systems must be considered in conjunction with this alternative to remove mobilized free product, thus increasing costs.

Conclusion

Steam injection is retained in combination with other process options for alternative development.

Biological

Biological remediation is a process in which indigenous microorganisms degrade organic contaminants found in soil. For petroleum hydrocarbons, oxygen is typically introduced to the contaminated media to enhance biological remediation. Biosparging was retained as a representative process option for in-situ biological treatment. Routine sampling is performed to monitor the progress of the remediation. Biological processes are typically slow.

Effectiveness

Bioremediation is an effective technology for organic contamination associated with fuels. Petroleum constituents, including PAHs are destroyed in this process. Some PAHs (e.g., naphthalene and 2-methylnaphthalene) are more biodegradable than others (benzo(a)pyrene). In the presence of free product, biodegradation is not as effective. The 2010 and 2011 bench scale studies showed that biosparging untreated soils resulted in a reduction of TPHs by up to 72% over a 60-day period (Tetra Tech, 2012). Since these studies used biosparging and a portion of the free product was removed by skimming, the amount of TPH reduction resulting from biodegradation is uncertain. Biosparging alone may require several years to achieve the cleanup goals.

Implementability

Biosparging is relatively common, and vendors and hardware required for remediation are readily available. The design of application systems would have to take into account site geology and contaminant depth.

Cost

Capital and O&M costs for biosparging would be low to moderate.

Conclusion

Biosparging is retained as a representative process option to be combined with other process options for the development of remedial alternatives.

Physical – Solvent Extraction

Contaminants in the subsurface are extracted with suitable non-aqueous solutions. Extraction fluids are passed through in-place soils using an injection and infiltration process. Extraction fluids must then be recovered from the underlying aquifer or destroyed (via biodegradation).

Effectiveness

Solvent extraction can be used to treat fuel contamination. Solvent extraction was demonstrated to be relatively effective at removing PAHs from Site 4 soil during bench scale testing (Appendix B).

Implementability

This technology would be considered innovative and vendors are not readily available. In addition, the regulatory acceptance of injecting a solvent, even one considered to be environmentally friendly, is uncertain.

Cost

Costs are moderate depending on the size of the injection well network, and whether the extent that additional treatment of extraction fluids is needed.

Conclusion

Solvent extraction is retained as an innovative technology to be combined with other process options for the development of remedial alternatives.

4.3 SELECTION OF REPRESENTATIVE PROCESS OPTIONS FOR SOILS

The following technologies are retained for the development of soil remedial alternatives:

- No Action
- Limited Action – LUCs and Monitored Natural Attenuation

- Excavation
- Off-site Disposal/Reuse
- Steam Injection and Free Product Recovery
- Beneficial Reuse of waste oil
- Insitu Biosparging
- Insitu Solvent Extraction

Table 4-3 presents a summary of the retained remedial technologies that will be developed into alternatives in Section 5.0. As noted previously, this FS/CMS is focused on the treatment of soil. However, groundwater will be treated with soil treatment. Also, contaminant reduction in groundwater can occur through natural attenuation.

4.4 SUSTAINABILITY

Sustainability is a process focused on energy conservation, reduction of greenhouse gases, waste minimization, and re-use and recycling of materials. These considerations are not NCP requirements for remedial alternatives, but may be considered during the technology and alternative selection process. Lifecycle analyses were performed using the Navy's SiteWise tool for a comparative analysis of alternatives, as provided in Section 5.0.

5.0 DEVELOPMENT AND EVALUATION OF REMEDIAL ALTERNATIVES

This section presents a development, description, and evaluation of remedial alternatives for management or treatment of COPCs in subsurface soils at Site 4 under CERCLA methodology. In addition, the alternatives are evaluated using RCRA criteria. The remedial alternatives are developed by assembling technologies and representative process options after the initial screening process (Section 4.0), considering the nature of the COPCs, concentrations, and site hydrogeologic conditions. These alternatives are not intended to represent final remedial alternatives, but are assembled to evaluate interactions between components. During the remedy selection process, other individual components can be selected as part of the final remedy. Table 5-1 provides additional details on the analysis factors and considerations of each alternative.

5.1 EVALUATION CRITERIA

Overall protection of Human Health and the Environment, Compliance with ARARs, Long-Term Reliability and Effectiveness, Reduction in Toxicity, Mobility, and Volume, Short-Term Effectiveness, Implementability, and Cost are presented in this FS/CMS to comply with CERCLA Feasibility Study guidance. Two additional criteria - State and Community Acceptance will be considered in the ROD based on comments received during review of the draft FS/CMS, Statement of Basis, and the Proposed Plan.

Overall Protection of Human Health and the Environment

This threshold evaluation criterion describes how each alternative provides and maintains adequate protection of human health and the environment. Alternatives are assessed to determine whether they can adequately protect human health and the environment from unacceptable risks posed by COPCs present at the site, in both the short- and long-term. This criterion is also used to evaluate how risks would be eliminated, reduced, or controlled through treatment, engineering, institutional controls, or other remedial activities.

Compliance with ARARs

This threshold evaluation criterion is used to determine if each alternative would comply with Federal and State ARARs. Other information, such as advisories, criteria, or guidance, is considered where appropriate during the ARARs analysis. Chemical-, location-, and action-specific ARARs for the alternatives presented in this FS/CMS are presented in Section 3.2.

Long-term Effectiveness and Permanence

This primary balancing evaluation criterion addresses the long-term effectiveness and permanence of maintaining the protection of human health and the environment after implementing the remedial action imposed by the alternative. The primary components of this criterion are the magnitude of residual risk remaining at the site after remedial objectives have been met, and the extent and effectiveness of controls that might be required to manage the risk posed by treatment residuals and/or untreated wastes.

Reduction of Toxicity, Mobility, or Volume through Treatment

This primary balancing evaluation criterion addresses the anticipated performance of the alternative's treatment technologies to permanently and significantly reduce toxicity, mobility, and/or volume of hazardous materials at the site. The NCP prefers remedial actions where treatment is used to reduce the principal threats at a site through destruction of toxic contaminants, irreversible reduction in contaminant mobility, or reduction of total volume of contaminated media.

Short-term Effectiveness

This primary balancing evaluation criterion considers the effect of each alternative on the protection of human health and the environment during the construction and implementation process. The short-term effectiveness evaluation only addresses protection prior to meeting the RAOs.

Implementability

This primary balancing criterion evaluates the technical feasibility and administrative feasibility (i.e., the ease or difficulty) of implementing each alternative and the availability of required services and materials during its implementation.

Cost

This primary balancing criterion evaluates the cost of implementing each alternative. The cost of an alternative encompasses all engineering, construction, and long-term future (e.g., O&M) costs incurred over the life of the project. The cost of each alternative is to be developed with an expected accuracy range of minus 30 to plus 50 percent (EPA, 1988).

These estimates were based on similar project experience, industry knowledge, and cost estimating references, as well as information provided by vendors, subcontractors, and regulators. However, these cost estimates were used to compare the alternatives. The costs of the remedial alternatives are compared using the estimated present value (PV) of the capital and long-term costs (e.g., O&M) of the

alternative in current year (2012) dollars. The PV allows costs for remedial alternatives to be compared by discounting all costs to the year that the alternative is implemented.

State Acceptance

This modifying criteria addresses the acceptability of the remedial alternatives to the state regulatory agencies. NYSDEC will review this FS/CMS, Proposed Plan, and ROD and provide comments and input as appropriate.

Community Acceptance

This modifying criteria addresses the acceptability of the remedial alternatives to the community. As with regulatory acceptance, community concerns will be used to evaluate each remedy in this FS/CMS. Consistent with RCRA and the NCP, public comments will be solicited on the selected alternative presented in the Proposed Plan and Statement of Basis. Comments will be addressed in the ROD and Permit Modification, and will be considered in selection of the remedy.

RCRA criteria to also be addressed under the CMS requirements are as follows.

Criterion 1 – Media Cleanup Standards

This criterion identifies whether the PRGs would be obtained and provides estimates for the time to achieve the PRGs. This criterion also evaluates steps that would be taken to control risks until the PRGs are obtained.

Criterion 2 – Source Control

This criterion provides a discussion of measures that would be taken to control or eliminate continuing sources of contamination and steps that would be taken to control migration or leaching of contaminants.

Criterion 3 – Waste Management Standards

This criterion identifies wastes that would be generated during the implementation of alternatives.

5.2 DEVELOPMENT AND EVALUATION OF REMEDIAL ALTERNATIVES FOR SOILS

The remedial alternatives developed and discussed in this section are as follows:

Alternative 1—No Further Action

Alternative 2—Monitored Natural Attenuation and Land Use Controls

Alternative 3—Steam Injection and Free Product Recovery

Alternative 4—Biosparging with Steam Injection and Free Product Recovery

Alternative 5—Solvent Extraction and Free Product Recovery with Biosparging

Alternative 6A—Excavation of Soils >1,000 mg/Kg TPH

Alternative 6B—Excavation of Soils >10,000 mg/Kg TPH

5.2.1 Alternative 1—No Action

Development

The No Action alternative is required under CERCLA to be evaluated as a baseline for other alternatives.

The No Action alternative does not include institutional controls or remedial activities to minimize risk to public health or the environment. Additionally, the No Action alternative does not include a monitoring program or five-year reviews.

Detailed Analysis of Alternatives

Overall Protection of Human Health and the Environment: Alternative 1 would not be protective of human health or the environment since no action is being taken to reduce site contamination or exposure routes. Over time, the PAH concentrations in soils would decrease through biodegradation and groundwater COPCs would attenuate. However, in the short-term contaminated soils would continue to impact groundwater that is used as public potable water. Remaining free product appears to be acting as a continuing source and that would continue for an extended period of time. There would be no notices or other actions in place to prevent exposure to possible contaminated groundwater. Although there are no plans currently identified, the contaminated soil could be excavated and used as common fill material.

Compliance with ARARs: Alternative 1 would not comply with the chemical-specific ARARs – NYSDEC Soil Cleanup Objectives [Chapter IV, Part 375, Subpart 375-6, Table 375-6.8(a)], or NYSDOH MCLs for groundwater (10 NYCRR Part 5, Subpart 5-1) or Federal drinking water standards (40 CFR 141 to 143, 40 CFR 149). There are no action- or location-specific ARARs.

Long-Term Effectiveness and Permanence: Alternative 1 would not be effective in the long term. Contaminated soils could continue to leach to groundwater and potentially impact local groundwater quality and potable water supplies. COPCs in groundwater exceed PRGs and pose a risk to human health. There would be no controls in place to monitor any potential effects to human health or the environment.

Reduction of Toxicity, Mobility, or Volume through Treatment: There would be no reduction of toxicity, mobility, or volume through treatment under this alternative. The PAHs and TPH in soils would degrade through natural in-situ biological activities.

Short-Term Effectiveness: There would be no risk to human health or the community during implementation of this alternative. Due to the depth of contamination, the only current potential risk to human health is through ingestion of contaminated groundwater. Although no actions are being taken to accelerate cleanup of soils, the RAOs would ultimately be achieved, although the timing of this compliance would be uncertain.

Implementability: Because no actions are being conducted, this alternative would be technically easy to implement.

Cost: There are no costs associated with Alternative 1.

Media Cleanup Standards: Alternative 1 would not achieve the PRGs, which were established to be protective of human health and the environment.

Source Control: Alternative 1 would not address source control.

Waste Management Standards: There are no actions to be implemented under this alternative, therefore no wastes would be generated.

5.2.2 Alternative 2—Monitored Natural Attenuation and Land Use Controls Development

MNA and LUCs are included in this alternative as a stand-alone remedial action, but are also a component of Alternatives 3 through 6. Natural attenuation is the remedial process for this remedy, and MNA is the implementation of that remedy in conjunction with soil and groundwater performance monitoring (e.g., monitoring the decrease of COPC concentrations over time). EPA objectives for performance monitoring of an MNA remedy are summarized below and evaluated in Table 5-2.

1. Demonstrate that natural attenuation is occurring according to expectations.
2. Detect changes in environmental conditions (e.g., hydrogeologic, geochemical, microbiological, or other changes) that may reduce the efficacy of any of the natural attenuation processes.
3. Identify any potentially toxic and/or mobile transformation products.
4. Verify that the plume is not expanding downgradient, laterally or vertically.
5. Verify no unacceptable impact to downgradient receptors.
6. Detect new releases of contaminants to the environment that could impact the effectiveness of the natural attenuation remedy.
7. Demonstrate the efficacy of institutional controls put in place to protect potential receptors.

8. Verify attainment of remediation objectives.

These performance monitoring objectives will be evaluated on an annual basis. EPA considers MNA to be a means of achieving remediation objectives for specific, well-documented sites where its use meets the applicable statutory and regulatory requirements.

The use of MNA differs from the No Action alternative because LUCs and performance monitoring continues until the RAOs are achieved.

Natural attenuation is the name given to the combination of natural processes occurring at a site that result in a decrease in concentration of a COPC with time or distance from a source. The most common destructive natural attenuation mechanism is biodegradation. PAHs are generally biodegradable in soil systems. Lower molecular weight PAH components are more water soluble than higher molecular weight PAHs. Readily mobilized compounds, such as naphthalene, phenanthrene, and anthracene, are slightly water-soluble. This means that a continuing source can provide a threat to groundwater. Persistent PAHs, such as chrysene and benzo(a)pyrene, have lower water solubilities. Other factors that affect PAH persistence include insufficient aerobic conditions. Contaminants may remain for substantial periods of time (FRTR, 2007). Once residual TPH degrades, COPCs in groundwater would attenuate.

MNA consists of the installation of a monitoring well network (already in place) and soil and groundwater monitoring. Additional soil borings (e.g., approximately 4 borings every 10 years) would be completed and analyzed for target COPCs (PAHs). Groundwater samples would be taken from the existing monitoring well network to determine if groundwater concentrations exceed PRGs and if they are migrating.

Groundwater samples would be collected annually until PRGs are obtained (e.g., 30 years). Groundwater from each well will be analyzed for VOCs, PAHs, and metals (see Appendix D).

Additional elements of Alternative 2 include LUCs for soil and groundwater use restrictions, annual inspections and five-year reviews, including the potential need to implement a more aggressive contingent remedy.

Detailed Analysis of Alternatives

Overall Protection of Human Health and the Environment: Alternative 2 is expected to be protective of human health and the environment. Over time, residual petroleum contamination and associated PAHs would degrade. LUCs would be used to provide notice and restrict use of contaminated groundwater for potable water applications until cleanup goals are met, as well as provide restrictions for use of soil for construction materials. Annual inspections would be conducted to identify the need for

deed changes based on site use. Once the remedy is in place, this Site will be transferred to Nassau County for redevelopment.

Compliance with ARARs: Ultimately, Alternative 2 would comply with chemical, location, and action specific ARARs. Chemical-specific ARARs would consist of NYSDOH MCLs (10 NYCRR 5, Subpart 5-1) and NYSDEC Soil Cleanup Objectives [Chapter IV, Part 375, Subpart 375-6, Table 375-6.8(a)].

Action-specific ARARs are limited to testing, management, and off-site disposal of IDW (6 NYCRR 372.2 and 373.1-1).

Long-Term Effectiveness and Permanence: Alternative 2 would be effective in the long term. LUCs would be used to restrict groundwater extraction for potable water use and provide notice of remaining soil contamination. These controls would be effective on Navy-controlled property, but would be less reliable off site, or when the Navy does not have direct control. The Navy will transfer Site 4 to Nassau County upon completion of the environmental investigation and remediation. Residual contamination will have deed notifications.

Reduction of Toxicity, Mobility, or Volume through Treatment: There would be no reduction of toxicity, mobility, or volume through treatment under this alternative. Residual soil contamination would degrade through natural in-situ biological activities. Non-hazardous soil and groundwater purge water wastes would be generated during implementation of this remedy. Facilities are readily available to transport and dispose of these materials.

Short-Term Effectiveness: Because activities are limited to administrative actions, soil boring completion, and groundwater monitoring activities, there would be no significant risk to human health or the community during implementation of this alternative. Although no actions are being taken to accelerate cleanup of site soils, the RAOs would ultimately be achieved, although the timing of this compliance would be uncertain. For cost estimates, there is an assumed 30 years of LUC administration and monitoring.

Implementability: LUCs and MNA are technically feasible and could be implemented within one year after signing of the ROD. The onsite LUCs and monitoring would be implemented by the Navy in consultation with NYSDEC. Services and materials are readily available to implement this remedy.

Cost: The estimated cost associated with Alternative 2 is as follows.

Capital Cost:	\$30,000
O&M:	\$35,000 per year, over 30 years (Groundwater Monitoring)
	\$50,000 every 10 years, over 30 years (Soil Sampling)

\$30,000 every five years, over 30 years (Five-Year Review and LUCs)

Present Value: \$1,100,000 (30 years)

Media Cleanup Standards: In the short term, Alternative 2 would not achieve the PRGs, which were established to be protective of human health and the environment. In the long term, attenuation of TPH and PAHs would occur and the leaching of contamination from soil to groundwater would decrease. Monitoring would be used to identify areas that would require LUCs to provide notice and restrict activities (e.g., potable groundwater use and removal of site soils) and identify leachability of contaminants to site groundwater.

Source Control: Alternative 2 would not involve additional source control.

Waste Management Standards: During groundwater sampling and the completion of soil borings, wastes would be generated. These materials would be containerized, characterized, and disposed off-site. Based on recent IDW management activity, none of these materials would be classified as RCRA hazardous wastes.

5.2.3 Alternative 3 – Steam Injection and Free Product Recovery Development

This alternative consists of injection of steam into subsurface soils and shallow groundwater to allow free product to form on the water table and a free product removal system. Institutional controls would remain in place while contamination remains at the site. LUCs would target areas that require notifications and/or inspections during implementation of this alternative, until cleanup goals are achieved. Monitoring would also be conducted to determine the effectiveness of the alternative. Both soil (four borings every ten years) and groundwater (annual) samples would be taken to determine if a reduction in soil concentrations was occurring and if residual soil contamination was continuing to leach to groundwater or otherwise impact groundwater.

Steam injection is an in-situ technology in which steam is introduced into the area of contaminated soil (TPH greater than 1,000 mg/Kg). This heating and agitation enhances the release of free product from the soil matrix. Steam injection will target saturated and unsaturated soils with greater than 1,000 mg/Kg TPH. Some VOCs and SVOCs can be stripped from the contaminated zone and removed along with the free product removal system. Steam is delivered to the subsurface through vertical injection wells. Based on the 2011 and 2012 bench scale studies, the soil and groundwater must be heated from approximately 50 degrees to at least 100 °F to mobilize the petroleum and form a floating free product. This temperature must then be maintained in both saturated and unsaturated soils for several years. In saturated soils, there will be additional heat loss due to groundwater flow through the area. The minimum heat requirement is estimated to be approximately 470 million BTU (see Appendix C for calculations). For cost estimating, it is assumed that the initial steam heating will occur over a 12-month period using a

50,000 BTU/hour steam generator (15 kilowatt [KW]) at 15 pounds per square inch (PSI). The steam generator will need approximately 17 gallons per hour of water, with approximately half of it will blow off to control salt deposits within the generator. The steam generator and a portion of the free product recovery system would be housed in a new steam generator building, as shown in Figure 5-1A.

The treatment zone obtained for each steam injection point varies based on the depth of the TPH-contaminated soil. As presented in Figure 5-1B, contamination is stratified in the subsurface. Because of the varying intervals of contamination, steam injection wells will be screened to different depths to better target the highest areas of contamination. The contamination is located between 20 and 71 feet bgs. Steam injection wells would be screened between 50, 60, or 70 feet bgs to target the entire zone of contamination, creating a heat treatment zone that is approximately 50 feet in thickness. Steam injection wells are assumed to be spaced on a 20-foot by 20-foot grid, as shown in Figure 5-1A. Approximately 14 clusters of steam injection wells, with a total of 28 steam injection wells, will be installed (see Figures 5-1B and 5-1C). Wells will be one-inch diameter and constructed of carbon steel. Utilities are present in the area and will have to be protected during treatment.

Free product recovery is the second component of this alternative. The free product recovery system utilizes vacuum-induced bioslurping to remove a mixture of free product, groundwater, and soil gas. The bioslurping system consists of approximately five free product recovery wells, a steel vacuum recovery tank, blower, vapor phase granular activated carbon (GAC) treatment system, oil/water separator, and a liquid phase GAC treatment system (see Figure 5-1C). The anticipated soil vapor extraction rate will be approximately 200 cubic feet per minute (CFM). This system is anticipated to operate 5 days a month for four years. The cost estimate assumes that the treated water will be discharged to the sanitary sewer and the free product would be disposed off-site.

Monitoring is estimated to consist of collecting and analyzing 20 soil samples twice over 16 years and analyzing them for TPH and PAHs, and sampling 11 monitoring wells on an annual basis for 16 years and analyzing the groundwater samples for VOCs, SVOCs, and metals.

Detailed Analysis

Overall Protection of Human Health and the Environment: Alternative 3 is expected to be protective of human health and the environment. Steam injection in combination with free product recovery would reduce residual TPH and PAH contamination in soil by mobilizing and removing free product until PRGs are met. Once the free product is removed, groundwater concentrations are expected to decrease through degradation and other attenuation factors. Off gases and waste water generated during free product recovery would be treated via vapor phase and liquid phase GAC treatment systems ensuring that emissions meet both New York air quality and groundwater quality standards. The top 20 feet of

soils contain little to no contamination, and would thus act as a barrier to exposure to the contaminated soil near the saturated zone.

Deed notifications and restrictions would remain in place until PRGs are met, preventing unacceptable risks from either groundwater or direct exposure to site soils. Monitoring would be conducted to determine the effectiveness of the remedy, and be protective of the environment by detecting potential continuing migration of soil contaminants to the groundwater. Many of the contaminants have limited mobility, so significant migration of contamination to groundwater is not expected.

Compliance with ARARs: This alternative would comply with chemical- and location-specific ARARs, because soil and groundwater PRGs would be achieved. These ARARs include achieving Class GA groundwater quality criteria, NYSDOH MCLs, and NYSDEC Subpart 375 Soil Cleanup Objectives.

This alternative would also comply with action-specific ARARs consisting of waste management ARARs for testing, management, and off-site disposal of IDW (Part 6 NYCRR 371, 372, and 373) and recovered free product (40 CFR 112 and 6 NYCRR Part 615), air discharges (6 NYCRR Part 212), and wastewater discharge via the Underground Injection Control (UIC) program (40 CFR 144).

Long-term Effectiveness and Permanence: Alternative 3 would be effective in the long term. Once the TPH and associated PAH are removed from the site and residual chemicals are allowed to attenuate, there would be no remaining site risks.

Reduction of Toxicity, Mobility, or Volume through Treatment: Alternative 3 would reduce the volume of contaminated soil through heating and free product recovery. The treatment system would address 6,800 cubic yards of contaminated soil and is anticipated to remove approximately 9,100 gallons of TPH during operation. Residual contamination would be addressed through natural biodegradation (10 tons). This alternative may require treatment of the extracted vapors and groundwater prior to discharge. GAC treatment of both of these waste streams has been assumed. Contaminants adsorbed on the GAC would be treated or disposed off-site.

Short-Term Effectiveness: There are some short-term effectiveness concerns associated with implementation of Alternative 3. Workers may be exposed to contamination and high heat during operation of the steam injection and free product recovery, but would be controlled by wearing PPE and complying with site specific health and safety procedures. Extracted groundwater and vapors will need to be treated prior to discharge. The associated liquid phase and vapor phase GAC will need to be disposed off-site. Alternative 3 is not anticipated to impact the surrounding community or environment. Depending on the effectiveness of the free product recovery and natural attenuation of the remaining TPH, the RAOs are anticipated to be achieved after approximately 10 to 16 years after the start of treatment.

Implementability: Equipment and personnel are available for this alternative. Utilities, including the primary electric feed system for facility that runs through the area, will need to be protected during implementation of this alternative. No permits will be required. The combination of steam injection and bioslurping treatments will require trained operators.

Cost: The estimated cost associated with alternative 3 is as follows.

Capital Cost:	\$1,800,000
O&M:	\$210,000 per year, over 4 years (Steam Injection/Product Recovery)
	\$35,000 per year, over 16 years (Groundwater Monitoring)
	\$51,000 every 8 years, over 16 years (Soil Sampling)
	\$30,000 every five years, over 16 years (Five-Year Review and LUCs)
Present Value:	\$3,400,000 (16 years)

A detailed cost estimate for this alternative is provided in Appendix D.

Media Cleanup Standards: Alternative 3 will achieve the PRGs, which were established to be protective of human health and the environment. Steam injection and free product recovery would be run over a 4-year time period, with monitoring continuing over an additional 12-year period to allow for attenuation processes to continue after free product is removed. PRGs are expected to be achieved after free product removal is completed. LUCs would remain until PRGs are met.

Source Control: This alternative actively remediates the continuing source of contamination through free product removal.

Waste Management Standards: During well installation, soil sampling, groundwater sampling, and operation of the free product recovery system, wastes will be generated. These materials will be containerized, characterized, and disposed off-site. None of these materials are expected to be classified as RCRA hazardous. In addition, the steam generator will have blowdown water that will need to be characterized and disposed. GAC treatment systems for off-gas and groundwater generated from free product recovery may need carbon change outs throughout implementation of recovery. Free product may either be disposed of or recycled.

5.2.4 Alternative 4 – Biosparging with Steam Injection and Free Product Recovery Development

This alternative consists of three major components including injecting steam into unsaturated soils to allow free product to form on the water table, a free product removal system, and biosparging of saturated and unsaturated soils. Institutional controls would remain in place while contamination remains at the site. LUCs would target areas that require notifications and/or inspections during implementation of this

alternative, until cleanup goals are achieved. Monitoring would also be conducted to determine the effectiveness of the alternative. Both soil and groundwater samples would be taken to determine if a reduction in soil concentrations was occurring and if residual soil contamination was continuing to leach to groundwater.

Steam injection is an in-situ technology in which steam is introduced into the area of contaminated soil. This heating and agitation enhances the release of free product from the soil matrix. Some VOCs and SVOCs can be stripped from the contaminated zone and removed along with the free product removal system. Steam is delivered to the subsurface through vertical injection wells. Based on the 2011 and 2012 bench scale studies, the soil and groundwater must be heated from approximately 50 degrees to at least 100 °F to allow the petroleum to flow to the water table and form a floating free product. This temperature must then be maintained for a period of months or years. The minimum heat requirement is estimated to be approximately 260 million BTU (see Appendix C for calculations). For cost estimating, it is assumed that the initial steam heating will occur over a 12-month period using a 30,000 BTU/hour steam generator (15 KW) at 15 PSI. The steam generator will need approximately 9 gallons per hour of water, with approximately half of it being blown off to control salt deposits within the generator. The steam generator and a portion of the free product recovery system would be housed in a new steam generator building, as shown in Figure 5-2A.

The treatment zone obtained for each steam injection targets only the unsaturated soils (Figure 5-2B) with greater than 10,000 mg/Kg TPH. Approximately six steam injection wells would be used (Figure 5-2A and 5-2C). Wells will be one-inch diameter and constructed of carbon steel. Utilities are present in the area and will have to be protected during treatment.

Free product recovery is the second component of this alternative. The free product recovery system utilizes vacuum-induced bioslurping to remove a mixture of free product, groundwater, and soil gas. The bioslurping system consists of approximately one free product recovery well, a steel vacuum recovery tank, blower, vapor phase GAC treatment system, oil/water separator, and a liquid phase GAC treatment system (see Figure 5-2C). The anticipated soil vapor extraction rate will be approximately 200 CFM. The free product recovery system is estimated to operate for two days every month for one year. The cost estimate assumes that the treated water will be discharged to the sanitary sewer and the free product would be disposed off-site. Free product can then be either disposed, or recycled as either oil or for asphalt.

Biosparging is the third component of this alternative. Biosparging will target unsaturated soils with greater than 1,000 mg/Kg TPH and saturated soil with greater than 10,000 mg/Kg TPH. During biosparging, air is injected into the subsurface to provide additional oxygen to increase biological degradation. Biosparging uses low air flow rates to stimulate microbial activity through direct air injection

into residual contamination. Volatile compounds are biodegraded as vapors move through biologically active soils. Vapors will normally be removed through a separate, low power blower (5 HP and 100 CFM). During the periodic operation of the free product recovery system, the low power blower will not operate. Vapors during both operations will be treated with GAC. A total of 14 air sparge wells will inject air at a rate of 5 CFM per well, for a total injection rate of 70 CFM (see Figures 5-2A, 5-2C). Note that air injection wells must be heat resistant (carbon steel). Wells will be screened below contamination in the saturated zone at 70 feet bgs (Figure 5-2B). A 15 PSI, 7 HP blower is required for biosparging (Figure 5-2C). Calculations for blower requirements and blower specifications are provided in Appendix C.

Monitoring is estimated to consist of collecting and analyzing 20 soil samples twice over ten years and analyzing them for TPH and PAHs, and sampling 11 monitoring wells on an annual basis for 10 years and analyzing the groundwater samples for VOCs, SVOCs, and metals.

Detailed Analysis

Overall Protection of Human Health and the Environment: Alternative 4 is expected to be protective of human health and the environment. Steam injection in the source area would reduce residual TPH and PAH contamination in soil by mobilizing and removing free product, while biosparging also volatilizes and promotes biodegradation of VOCs, TPH, and PAHs until PRGs are met. Over time, groundwater concentrations are also expected to decrease through degradation and precipitation or adsorption once the source of free product is removed and remaining contamination in soils is reduced through biological degradation. Off gases and waste water generated during free product recovery would be treated via vapor phase and liquid phase GAC treatment systems ensuring that emissions meet both New York air quality and groundwater quality standards. The free product recovery and low power blower systems would also remove vapors created during biosparging which would be treated through the same GAC treatment system before being vented to the atmosphere. The top 20 feet of soils contain little to no contamination, and would thus act as a barrier to exposure to the contaminated soil near the saturated zone during remediation.

Deed notifications and restrictions would remain in place until PRGs are met, preventing unacceptable risks from either groundwater or direct exposure to site soils. Monitoring would determine the effectiveness of the remedy, and be protective of the environment by detecting potential continuing migration of soil contaminants to the groundwater. Many of the contaminants have limited mobility, so significant migration of contamination to groundwater is not expected.

Compliance with ARARs: This alternative would comply with chemical- and location-specific ARARs, because soil and groundwater PRGs, the basis for the PRGs, would be achieved. These ARARs include achieving Class GA groundwater quality criteria, NYSDOH MCLs, and NYSDEC Subpart 375 Soil Cleanup Objectives.

This alternative would also comply with action-specific ARARs consisting of waste management ARARs for testing, management, and off-site disposal of IDW (Part 6 NYCRR 371, 372, and 373) and recovered free product (40 CFR 112 and 6 NYCRR Part 615), air discharges (6 NYCRR Part 212), and wastewater discharge via the UIC program (40 CFR 144).

Long-term Effectiveness and Permanence: Alternative 4 would be effective in the long term. Once the TPH and associated PAH are removed from the site and residual chemicals are allowed to attenuate, there would be no remaining site risks.

Reduction of Toxicity, Mobility, or Volume through Treatment: Alternative 4 would reduce the volume of contaminated soil through heating and free product recovery and biodegradation. The thermal/free product recovery system is designed to mobilize and remove approximately 7,900 gallons of TPH during operation. Other organic contaminants would be treated through insitu biodegradation (14 tons of TPH). This alternative may require treatment of the extracted vapors and groundwater prior to discharge. GAC treatment of both of these waste streams has been assumed. Contaminates adsorbed on the GAC would be treated or disposed off-site.

Short-Term Effectiveness: There are some short-term effectiveness concerns associated with implementation of Alternative 4. Workers may be exposed to contamination and high heat during operation of the steam injection and free product recovery, but would be controlled by wearing PPE and complying with site specific health and safety procedures. Extracted groundwater and vapors will need to be treated prior to discharge. The associated liquid phase and vapor phase GAC will need to be disposed off-site. Alternative 4 will not impact the surrounding community or environment. The RAOs will be achieved upon removal of the free product, biosparging of residual contamination, and implementation of deed restrictions for remaining contamination. Depending on the effectiveness of the free product recovery and biosparge systems, the RAOs are anticipated to be achieved after approximately 4 to 10 years after the start of treatment.

Implementability: Equipment and personal are available for this alternative. Utilities, including the primary electric feed system for facility that runs through the area, will need to be protected during implementation of this alternative. No permits will be required.

The combination of steam injection and bioslurping treatments will require trained operators.

Cost: The estimated cost associated with alternative 4 is as follows.

Capital Cost:	\$1,800,000
O&M:	\$200,000 per year, over 2 years (Steam Injection/Product Recovery)
	\$39,000 per year, over 4 years (Biosparging)

	\$35,000 per year, over 10 years (Groundwater Monitoring)
	\$51,000 every 2 years, over 4 years (Soil Sampling)
	\$30,000 every five years, over 10 years (Five-Year Review and LUCs)
Present Value:	\$2,900,000 (10 years)

A detailed cost estimate for this alternative is provided in Appendix D.

Media Cleanup Standards: Alternative 4 will achieve PRGs, which were established to be protective of human health and the environment. Steam injection and free product recovery is anticipated to be conducted for two years, biosparging is anticipated to be conducted for four years (two years concurrent with the free product recovery), and monitoring is anticipated to be conducted for an additional 6 years (10 years total). LUCs would remain until PRGs are met.

Source Control: This alternative actively remediates the continuing source of contamination through free product removal and biodegradation.

Waste Management Standards: During well installation, soil sampling, groundwater sampling, and operation of the free product recovery system, wastes will be generated. These materials will be containerized, characterized, and disposed off-site. None of these materials are expected to be classified as RCRA hazardous. In addition, the steam generator will have blowdown water that will need to be characterized and disposed. GAC treatment systems for off-gas and groundwater generated from free product recovery may need carbon change outs throughout implementation of recovery. Free product may either be disposed of or recycled.

5.2.5 Alternative 5 – Solvent Extraction and Free Product Recovery with Biosparging Development

This alternative consists of three major components including injecting solvent into unsaturated and saturated soils to allow free product to form on the water table, a free product removal system, and biosparging of both saturated and unsaturated soils. Institutional controls would remain in place while contamination remains at the site. LUCs would target areas that require notifications and/or inspections during implementation of this alternative, until cleanup goals are achieved. Monitoring would also be conducted to determine the effectiveness of the alternative. Both soil and groundwater samples would be taken to determine if a reduction in soil concentrations was occurring and if residual soil contamination was continuing to leach to groundwater.

Solvent injection is the first component of this alternative. Vertec will be injected both above and below the water table to saturate the TPH contaminated soils (greater than 10,000 mg/Kg). Most of the extraction fluids would be recovered from the water table. Remaining solvent will be biodegraded via biosparging. As the solvent passes through the soil, the existing free product is absorbed and flows with

the solvent to the water table where it can then be removed through free product recovery. An estimated 56 solvent injection wells will be installed (see Figure 5-3A). Twelve of those 56 wells will be dual air sparge and solvent injection wells, screened to a depth of 70 feet bgs (see Figure 5-3B). The remaining 44 wells will be screened from 20 to 50 feet bgs to saturate soils above the water table. Solvent injection wells are spaced approximately 10 feet apart, as shown in Figure 5-3A. A total of 120,000 gallons of Vertec would be required. Approximately 90,000 gallons of Vertec containing approximately 9,800 gallons of TPH would be recovered from the water table, and the balance of the petroleum (6 tons) would be degraded by biosparging.

Free product recovery is the second component of this alternative. The free product recovery system uses submersible pumps to extract free product. The free product recovery system consists of 5 submersible pumps (1 per well), and a waste oil tank (10,000 gallons) where free product can be decanted and stored (see Figure 5-3C). Five free product recovery wells will be installed within the 10,000 mg/Kg TPH contour (see Figure 5-3A), and screened from 40 to 60 feet bgs (see Figures 5-3B). Free product can then be either disposed, or recycled.

Biosparging is the third component of this alternative. During biosparging, air is injected into the subsurface to provide additional oxygen to increase biological degradation and remediate remaining contamination and solvent. A total of 12 air injection wells (these wells are dual air and solvent injection) will inject air at a rate of 5 CFM per well, for a total injection rate of 60 CFM (see Figures 5-3A, 5-3C). Wells will be used for solvent injection initially and later for biosparging only. Wells will be screened below contamination in the saturated zone at 70 feet bgs (Figure 5-3B). A 15 PSI, 6 HP blower is required for biosparging (Figure 5-3C). Calculations for blower requirements and blower specifications are provided in Appendix C. A 10-foot by 20-foot blower building and staging area is shown on Figure 5-3A.

Monitoring is estimated to consist of collecting and analyzing 20 soil samples twice over four years and analyzing them for TPH and PAHs, and sampling 11 monitoring wells on an annual basis for 10 years and analyzing the groundwater samples for VOCs, SVOCs, and metals.

Detailed Analysis

Overall Protection of Human Health and the Environment: Alternative 5 is expected to be protective of human health and the environment. Solvent injection in the source area coupled with free product recovery would reduce residual TPH and PAH contamination, while biosparging volatilizes and/or biodegrades VOCs, PAHs, and treats residual solvent until PRGs are met. Over time, groundwater concentrations are also expected to decrease through degradation and precipitation or adsorption once the source of free product is removed and remaining contamination in soils is reduced through biological degradation. The top 20 feet of soils contain little to no contamination, and would thus act as a barrier to exposure to the contaminated soil near the saturated zone during remediation.

Deed notifications and restrictions would remain in place until PRGs are met, preventing unacceptable risks from either groundwater or direct exposure to site soils. Monitoring would be conducted to determine the effectiveness of the remedy, and be protective of the environment by detecting potential continuing migration of soil contaminants to the groundwater. Many of the contaminants have limited mobility, so significant migration of contamination to groundwater is not expected.

Compliance with ARARs: This alternative would comply with chemical- and location-specific ARARs, because soil and groundwater PRGs, the basis for the PRGs, would be achieved. These ARARs include achieving Class GA groundwater quality criteria, NYSDOH MCLs, and NYSDEC Subpart 375 Soil Cleanup Objectives.

This alternative would also comply with action-specific ARARs consisting of waste management ARARs for testing, management, and off-site disposal of IDW (Part 6 NYCRR 371, 372, and 373) and recovered free product (40 CFR 112 and 6 NYCRR Part 615), air discharges (6 NYCRR Part 212), and wastewater discharge via the UIC program (40 CFR 144).

Long-term Effectiveness and Permanence: Alternative 5 would be effective in the long term. Once the TPH and associated PAH are removed from the site and residual chemicals are allowed to attenuate, there would be no remaining site risks.

Reduction of Toxicity, Mobility, or Volume through Treatment: Alternative 5 would reduce the contaminant toxicity of PAHs, VOCs, and TPH through in-situ treatment that removes or biodegrades the continuing source and thereby reduces the mobility and toxicity of remaining contamination to groundwater. The solvent injection system is designed to mobilize and remove approximately 9,800 gallons of TPH during operation. Residual contamination (6 tons) would be addressed through insitu biodegradation. This alternative may require treatment of the extracted vapors and groundwater prior to discharge. GAC treatment of both of these waste streams has been assumed. Contaminants adsorbed on the GAC would be treated or disposed off-site.

Short-Term Effectiveness: There are some short-term effectiveness concerns associated with implementation of Alternative 5. Potential exposure of workers to contamination during installation and operation of the alternative would be minimized by wearing PPE and complying with site specific health and safety procedures. The associated liquid phase and vapor phase GAC will need to be disposed off-site. Alternative 5 will not impact the surrounding community or environment. The RAOs will be achieved upon removal of the source (free product) and biosparging of solvent residuals, and implementation of deed notifications for remaining contamination. PRGs will be obtained after degrading solvent residuals, however; this is estimated to require 4 to 10 years after the start of treatment.

Implementability: Equipment and personal are available for this alternative. Utilities, including the primary electric feed system for the facility that runs through the area, will need to be protected during implementation of this alternative. Biosparging has been proven effective in remediation of petroleum contamination, and vendors are readily available for this technology. The injection well network must take into account site geology to provide adequate removal of TPH. A large quantity of solvent would be needed for the initial saturation of site soils. Extraction fluids would need to be recovered from the aquifer and/or degraded. Injection of solvent into an aquifer to remove petroleum is not a well demonstrated technology, but operation of free product recovery systems are common.

A UIC permit equivalent would be required for this alternative. Because of the innovative technology, obtaining this permit may be difficult. Deed notifications would be in place while contamination remains.

Cost: The estimated cost associated with alternative 5 is as follows.

Capital Cost:	\$1,600,000
O&M:	\$680,000 per year, over 2 years (Solvent Injection/Product Recovery)
	\$39,000 per year, over 4 years (Biosparging)
	\$35,000 per year, over 10 years (Groundwater Monitoring)
	\$51,000 every 2 years, over 4 years (Soil Sampling)
	\$30,000 every five years, over 10 years (Five-Year Review and LUCs)
Present Value:	\$3,700,000 (10 years)

A detailed cost estimate for this alternative is provided in Appendix D.

Media Cleanup Standards: In the short term, Alternative 5 would not achieve PRGs, which were established to be protective of human health and the environment. Solvent injection, biosparging and free product recovery would continue over a 4-year time period, with monitoring continuing over an additional 6-year period to allow for attenuation processes to continue after free product is removed and residual solvent is biodegraded. PRGs are expected to be achieved after biosparging is completed. LUCs would remain until PRGs are met.

Source Control: This alternative actively remediates the continuing source of contamination through free product removal and biodegradation of remaining solvent and soil contamination.

Waste Management Standards: During well installation, soil sampling, groundwater sampling, operation of the free product recovery system, and solvent injection, wastes will be generated. These materials will be containerized, characterized, and disposed off-site. None of these materials are expected to be classified as RCRA hazardous. Free product may either be disposed of or recycled.

5.2.6 Alternative 6 – Excavation and Disposal of Soils (Alternative 6A greater than 1,000 mg/Kg TPH and Alternative 6B greater than 10,000 mg/Kg)

Development

Alternative 6 consists of three major components including excavation of soils, off-site disposal of contaminated soil, replacement of uncontaminated soil, and institutional controls and monitoring. Alternative 6A would target removal of soil containing greater than 1,000 mg/Kg TPH and Alternative 6B would target removal of soil containing greater than 10,000 mg/Kg TPH for off-site disposal.

Excavation involves the removal of soils with concentrations of COPCs above PRGs. Contaminated soils are delineated to approximately 71 feet bgs, or shallower in some areas (see Figures 2-3, 2-4). Because of the depth of contamination, shoring would be installed prior to excavation (see Appendix C). An area, approximately 80 by 100 feet, as shown on Figure 5-4A, would be excavated to a depth of up to 71 feet bgs (see Figures 5-4B). This corresponds to a volume of approximately 21,000 cubic yards of excavated material. Uncontaminated soil would be stockpiled for use as backfill (see Figure 5-4A for the proposed soil staging area). To reach the target depth, excavation of material below the water table would be required. Excavated saturated soils would have to be dewatered. After completion of the excavation, the bottom of the excavated area would be sampled and analyzed to confirm that PRGs have been met. Following excavation, the excavated area would be backfilled with clean fill and re-graded. Portions of the area would require soil cover, while other portions of the area would require re-paving. For Alternative 6A, approximately 21,000 cubic yards of soil would be excavated, and approximately 7,000 cubic yards containing 47 tons of TPH would be disposed off-site (Figure 5-4C). For Alternative 6B, approximately 8,000 cubic yards of soil would be excavated, and approximately 1,400 cubic yards containing 30 tons of TPH would be disposed off-site (Figure 5-4D). Detailed calculations are provided in Appendix C.

Excavated soils would be transported off-site and disposed at a permitted solid waste disposal facility. The soil is expected to be nonhazardous and could be disposed in a RCRA Subtitle D landfill. Samples of the soil will be collected and analyzed to ensure that the soil complies with the landfill permit. Excavation below the water table would be limited because of problems with handling saturated soil, and institutional controls will be in place while contamination remains. Monitoring to observe changes in groundwater contamination after the source material is removed would continue for 4 years.

Monitoring is estimated to consist of sampling 11 monitoring wells on an annual basis for 4 years (Alternative 6A) or 12 years (Alternative 6B) and analyzing the groundwater samples for VOCs, SVOCs, and metals.

Detailed Analysis

Overall Protection of Human Health and the Environment: Alternatives 6A and 6B are expected to be protective of human health and the environment. Removal of the contaminated soil would reduce (Alternative 6B) or eliminate (Alternative 6A) TPH and PAH contamination at the site. Residual contamination (Alternative 6B) would be addressed through natural attenuation. Alternative 6A would achieve the RAOs once the excavation and off-site disposal is complete. For Alternative 6B, LUCs would prevent unacceptable risk from either groundwater or direct contact to site soils. Off-site disposal of contaminated soil at a permitted facility would protect human health and the environment.

Compliance with ARARs: These alternatives would comply with chemical- and location-specific ARARs, because soil and groundwater PRGs, the basis for the PRGs, would be achieved. These ARARs include achieving Class GA groundwater quality criteria, NYSDOH MCLs, and NYSDEC Subpart 375 Soil Cleanup Objectives.

This alternative would also comply with action-specific ARARs consisting of waste management ARARs for testing, management, and off-site disposal of excavated soil (Part 6 NYCRR 371, 372, and 373).

Long-term Effectiveness and Permanence: Alternatives 6A and 6B would be effective in the long term. Once the TPH and associated PAHs are removed from the site and residual chemicals are allowed to attenuate, there would be no remaining site risks.

Reduction of Toxicity, Mobility, or Volume through Treatment: Alternatives 6A or 6B would not reduce toxicity, mobility, and volume of contaminants through treatment. Approximately 7,000 cubic yards contaminated with 47 tons of TPH (Alternative 6A) or 1,400 cubic yards contaminated with 30 tons of TPH (Alternative 6B) would be removed from the site with the full excavation.

Short-Term Effectiveness: Implementation of Alternatives 6A or 6B could expose construction workers to contaminated soil. Potential exposure of workers to contamination during installation and operation of the alternative would be minimized by wearing PPE and complying with site specific health and safety procedures. The potential for exposure would be minimized by the implementation of engineering controls, such as dust suppression, and air-quality monitoring. This alternative may have a minor impact on the surrounding community because of transporting waste from the site. Spill prevention, containment, erosion and sedimentation control, and perimeter air monitoring would be done to ensure that the impact remains acceptable. The excavation and off-site disposal portions of Alternatives 6A or 6B would be completed in approximately 2 to 3 years. The RAOs for Alternative 6A would be achieved within approximately 2 to 4 years after the excavation is complete, whereas Alternative 6B may require approximately 10 years after the excavation is complete.

Implementability: Although there are technical challenges, Alternatives 6A and 6B could be implemented. The necessary excavation would be relatively deep and in close proximity to structures, and the shallow angle of excavation would require an extensive shoring system since the bulk of the contamination is located at or below the water table. Existing utilities would have to be removed and/or relocated. In addition, saturated soils would need to be dewatered. A non-hazardous waste landfill for the off-site disposal of the soil is available.

Cost: The estimated cost associated with Alternatives 6A and 6B are as follows.

Capital Cost:	Alternative 6A: \$7,800,000
	Alternative 6B: \$4,100,000
O&M:	Alternative 6A: \$35,000 per year, over 4 years (Groundwater Monitoring) \$30,000 every five years (Five-Year Review and LUCs)
	Alternative 6B: \$35,000 per year, over 12 years (Groundwater Monitoring) \$30,000 every five years (Five-Year Review and LUCs)
Present Value:	Alternative 6A: \$8,000,000 (4 years)
	Alternative 6B: \$4,500,000 (12 years)

A detailed cost estimate for this alternative is provided in Appendix D.

Media Cleanup Standards: Alternative 6A and 6B would achieve PRGs, which were established to be protective of human health and the environment because the source of contamination will be removed. Alternative 6A would achieve PRGs 2 to 4 years after the excavation is complete, whereas Alternative 6B would require approximately 10 additional years.

Source Control: This alternative actively remediates the continuing source of contamination through removal.

Waste Management Standards: Waste soils will be disposed of in a permitted facility. Soils are not expected to be hazardous. IDW will be generated during the limited soil and groundwater sampling, and will be containerized, characterized, and disposed.

5.3 COMPARATIVE ANALYSIS OF ALTERNATIVES

This section compares the analyses that were presented for each of the remedial alternatives. The criteria for comparison are identical to those used for the detailed analysis of individual alternatives.

The following remedial alternatives for soil are being compared in this section:

- Alternative 1—No Further Action
- Alternative 2—Monitored Natural Attenuation and Land Use Controls
- Alternative 3—Steam Injection and Free Product Recovery

- Alternative 4—Biosparging with Steam Injection and Free Product Recovery
- Alternative 5—Solvent Extraction and Free Product Recovery with Biosparging
- Alternative 6A—Excavation of Soils >1,000 mg/Kg TPH
- Alternative 6B—Excavation of Soils >10,000 mg/Kg TPH

A comparative analysis of alternatives is summarized in Table 5-3.

5.3.1 Overall Protection of Human Health and the Environment

Alternative 1 is not protective of human health and the environment, and would not meet PRGs because no actions would be taken to eliminate risks from remaining contamination. Soil COPCs could still migrate to the groundwater.

Alternative 2 would be protective of human health and the environment because RAOs are expected to be met through LUCs and monitoring of soil and groundwater. However, soil COPCs could continue to migrate to groundwater, which would be monitored and continuing risks would be mitigated through administrative restrictions which would prevent the use of contaminated groundwater.

Alternatives 3, 4, and 5 are protective of human health and the environment because contaminated soils will be remediated through in-situ treatment and residual soil and groundwater contamination will meet the PRGs through natural biodegradation. Alternatives 3 and 4 would treat source soils with steam injection and/or biosparging to mobilize free product for removal. Alternative 5 would treat soils through solvent injection to mobilize free product to the water table and allow for its removal. Residual soil and groundwater contamination are expected to decrease through natural attenuation processes once source free product is removed. Biosparging would aid natural attenuation processes in Alternatives 4 and 5 and also degrade residual solvent in Alternative 5. LUCs would be in place while contamination remains, and would be protective of human health and the environment.

Alternative 6A achieves protection of human health and the environment through removal of contaminated media, whereas Alternative 6B achieves this protection through removal of the most contaminated soils and allows the remaining contaminated soils to be remediated through natural attenuation processes. Off-site disposal of contaminated soil at a permitted facility would be protective of human health and the environment.

5.3.2 Compliance with ARARs

Alternative 1 would not comply with chemical-specific ARARs for soils including NYSDEC Soil Cleanup Objectives, Federal EPA RSL values, or chemical-specific ARARs for groundwater including NYSDOH MCLs or Federal drinking water standards. No location- or action-specific ARARs apply to this alternative.

Alternatives 2 through 6B would comply with ARARs when the remedy is complete, including the chemical- and location-specific ARARs, because soil and groundwater PRGs would be achieved. These ARARs include achieving Class GA groundwater quality criteria, NYSDOH MCLs, and NYSDEC Subpart 375 Soil Cleanup Objectives.

Action-specific ARARs consist of waste management ARARs for testing, management, and off-site disposal of IDW (Alternatives 2 through 6B), recovered free product (Alternatives 3, 4, and 5), air discharges (Alternatives 3, 4, and 5), wastewater discharge (Alternatives 3, 4, and 5), and solvent injection (Alternative 5) via the UIC program (40 CFR 144).

5.3.3 Long-term Effectiveness and Permanence

Alternative 1 is not effective in the long term. Contaminated soils could continue to leach to groundwater and impact potable water supplies. SVOCs in groundwater exceed PRGs and pose a risk to human health. There would be no controls in place to monitor potential effects.

Alternatives 2, 3, 4, 5, 6A, and 6B would be effective in the long term. At the completion of the remedy, site contaminants would be below PRGs and allow unlimited use/unlimited exposure in the area.

5.3.4 Reduction of Toxicity, Mobility, or Volume through Treatment

There would be no reduction of toxicity, mobility or volume through treatment with Alternatives 1, 2, 6A, or 6B. PAH and TPH contamination in soils would degrade through natural biological activity.

Under Alternative 3, thermal treatment and free product recovery will remove approximately 9,100 gallons of TPH. Under Alternative 4, a combination of thermal treatment, air agitation, and free product recovery will remove approximately 7,900 gallons of TPH. Under Alternative 5, solvent extraction would remove approximately 9,800 gallons of TPH. The recovered TPH would be sent off-site to be burned or recycled. Alternatives 4 and 5 also use biosparging to degrade TPH and PAHs and would form aerobic conditions that would allow metals in groundwater to precipitate. GAC treatment of extracted groundwater and air would be used to treat water and air streams. The GAC would be landfilled or regenerated. Remaining contamination will be reduced through natural attenuation and verified by monitoring.

Alternatives 6A and 6B would not have a reduction of toxicity, mobility, or volume through treatment. For Alternative 6A, approximately 7,000 cubic yards of soil contaminated with 47 tons of TPH would be removed from the site through full excavation. For Alternative 6B, approximately 1,400 cubic yards contaminated with 30 tons of TPH would be removed from the site through partial excavation. Remaining contamination associated with Alternative 6B would degrade through natural biological activity.

5.3.5 Short-term Effectiveness

Alternative 1 is not effective in the short term. Contamination will remain and possibly continue to leach to groundwater. Alternative 2 would be partially effective in the short term. LUCs would be protective while contamination remains, and soil and groundwater would be monitored for remaining risks.

Alternatives 3 through 6B would be effective in the short term. Each of the alternatives results in some potential risk to site workers. Steam injection and free product recovery systems under Alternatives 3 and 4 would provide added risks to workers from thermal burns. Also, Alternatives 3, 4, and 5 would form offgas and wastewater streams that would need to be treated. LUCs would be protective while contamination remains. PRGs will be attained after free product removal, treatment, and natural attenuation of residual contamination occurs.

Because large quantities of waste will be transported through the community, Alternative 6A and 6B result in some risk to the community during implementation. In addition, there is some risk to site workers during the excavation. Engineering controls like dust suppression and air quality monitoring as well as spill prevention, containment, and erosion control will be implemented.

Alternatives 6A will achieve the PRGs in the shortest time (4 years), followed by Alternatives 4 and 5 (10 years), Alternative 6B (12 years), Alternative 3 (16 years), and Alternative 2 (30 years).

5.3.6 Implementability

Each of the alternatives are implementable. Alternatives 1 and 2 are easy to implement, with readily available resources for Alternative 2.

Alternatives 3, 4, and 5 are more difficult to implement. Vendor and equipment are available. Free product recovery and biosparging technologies are commonly available. However, steam injection systems are conducted on a more limited basis, and solvent extraction would be considered an innovation technology.

Alternatives 6A and 6B would be the most difficult to implement. Feasibility of these alternatives is uncertain due to the depth of excavation required. The shoring system is one of the most significant portions involved in planning this alternative. Contamination exists in saturated soils, and removal of saturated soils must take into account dewatering and other processes. Storage availability of soils on site is limited. Existing structures and utilities would need to be removed or relocated during implementation of this alternative. Construction worker safety would be a significant issue.

5.3.7 Cost

There are no costs associated with implementation of Alternative 1. Alternative 6A is the most expensive alternative to implement. A full summary of costs associated with the alternative is provided in Table 5-4. Detailed cost analyses are provided in Appendix D.

5.3.8 Media Cleanup Standards

Alternative 1 does not achieve PRGs because no action is taken to remediate the source of contamination.

In the short term, Alternatives 2, 3, 4, and 5 would not achieve PRGs. However, Alternatives 2 through 5 would achieve PRGs in the long term through free product recovery (Alternatives 3, 4, and 5), biodegradation (Alternatives 4, and 5), excavation (Alternative 6A and 6B), and attenuation of remaining contamination (Alternatives 2 to 6), with LUCs in place while contamination remains. Groundwater is expected to meet PRGs within two to six years, once the source area soils are remediated.

5.3.9 Source Control

Alternatives 1 and 2 do not involve source area control. Alternatives 2 through 5 involve active remediation of the source through treatment with steam injection, biosparging and/or solvent injection. Alternatives 6A and 6B involve source control through removal.

5.3.10 Waste Management Standards

Alternative 1 does not generate waste because no actions are taken.

Alternatives 2 through 6B generate non-hazardous IDW wastes from sampling of soils and groundwater in association with monitoring and/or treatment.

Alternatives 3 and 4 will generate blowdown water from the steam generator that will need to be characterized and disposed (accumulation of salts). Additional treatment would be required for air and groundwater removed with the free product recovery systems associated with Alternatives 3 and 4. GAC treatment systems for both liquid-phase and vapor-phase systems are anticipated and would require carbon regeneration or disposal during remedial system operation. The treated groundwater would also have to be disposed. Reuse of both water streams at the site may be considered. The free product removed from recovery systems will be recycled or disposed.

Under Alternative 5, disposal of waste Vertec solvent will also be required. Similar to Alternatives 3 and 4, free product removed from recovery systems will be recycled or disposed.

Alternatives 6A and 6B will generate soils from excavation that will require disposal in a RCRA Subtitle D facility or may be considered for beneficial reuse (asphalting plant).

5.4 LIFE-CYCLE ANALYSIS AND OPTIMIZATION

Optimization fundamentally is a practice of systematically employing sound engineering and decision making processes to enhance the effectiveness and efficiency of a remedial project. These are commonly conducted throughout the life-cycle of a remedial project, from remedy selection through decommissioning. Project efficiencies can be gained in each phase, thereby shortening remedial implementation cost, time span, material usage intensity, energy dependency, etc. Periodic optimization and sustainability evaluations throughout the project life-cycle are an effective means of continually improving remedy effectiveness, controlling life-cycle costs, and reducing the overall environmental footprint, such as greenhouse gas emissions, energy usage, and other resource consumption. The results of the sustainability evaluations illustrate the benefits of continued optimization reviews and sustainability evaluations at each phase.

5.4.1 Objective

The Environmental Footprint Evaluation of remedial alternatives inputs and results are provided in Appendix E. The purpose of the footprint evaluation is to assess the environmental impacts of the six remedial alternatives using the metrics of greenhouse gas (GHG) and criteria pollutant emissions, energy use, water consumption, and worker safety. The results of this footprint evaluation are intended to provide additional information for consideration during remedy selection, design, and to enhance the understanding of the environmental impacts throughout the remedy life-cycle for each of the proposed alternatives.

5.4.2 Sustainability Evaluation Policy Background

Department of Defense (DOD) and Navy policies require continual optimization of remedies in every phase from remedy selection through site closeout (NAVFAC, 2010a).

In January 2007, Executive Order 13423 set targets for sustainable practices for (i) energy efficiency, greenhouse gas emissions avoidance or reduction, and petroleum products use reduction, (ii) renewable energy, including bioenergy, (iii) water conservation, (iv) acquisition, (v) pollution and waste prevention and recycling, etc. In October 2009, Executive Order 13514 was issued, which reinforced these sustainability requirements and established specific goals for federal agencies to meet by 2020.

In August 2009, DOD issued a policy for “Consideration of Green and Sustainable Remediation Practices in the Defense Environmental Restoration Program.” The DOD policy and related Navy guidance state that opportunities to increase sustainability should be considered throughout all phases of remediation

(i.e., site investigation, remedy selection, remedy design and construction, operation, monitoring, and site closeout). In response to this policy, the Department of the Navy (DON) issued an updated Navy Guidance for “Optimizing Remedy Evaluation, Selection, and Design” (NAVFAC, 2010b), which includes environmental footprint evaluations as part of the traditional DON optimization review process for remedy selection, design, and remedial action operation. In August 2010, the Naval Facilities Engineering Command (NAVFAC) issued policy requiring use of the SiteWise™ tool to perform environmental impact reviews as part of all Feasibility Studies. As such, this environmental footprint evaluation of remedial alternatives is being performed to estimate the environmental footprint associated with each alternative in the interest of reducing the environmental impact of remedial action at the Naval Weapons Industrial Reserve Plant.

Applying the DON optimization concepts with an environmental footprint evaluation within the remedy selection and design phases allows for the following benefits:

- Determining factors in each remedial alternative with the greatest environmental impacts and gathering insight into how to reduce these impacts;
- Evaluating remedial alternatives with optimized or reduced environmental footprints in conjunction with other selection criteria;
- Designing and implementing a more robust remedy while balancing the impact to the environment; and
- Ensuring efficient, cost-effective and sustainable site closeout.

5.4.3 Evaluation Tools

This evaluation was performed using a hybrid model consisting of the Navy’s SiteWise™ tool supplemented with a Tetra Tech developed model as appropriate for some site-specific items.

SiteWise™ is a life-cycle footprint assessment tool developed jointly by the U.S. Navy, U.S. Army Corps of Engineers (USACE), and Battelle. SiteWise™ assesses the environmental footprint of a remedial alternative/technology using a consistent set of metrics. The assessment is conducted using a building block approach, where every remedial alternative is first broken down into modules that follow the phases for most remedial actions, including Remedial Investigation (RI), remedial action construction (RA-C), remedial action operation (RA-O), and long-term monitoring (LTM). Once broken down by remedial phase, the footprint of each phase is calculated. The phase-specific footprints are then combined to estimate the overall footprint of the remedial alternative. This building block approach reduces redundancy in the footprint assessment and facilitates the identification of specific impact drivers that contribute to the environmental footprint. The inputs that need to be considered include (1) production of material required by the activity; (2) transportation of the required materials to the site, transportation of

personnel; (3) all site activities to be performed; and (4) management of the waste produced by the activity.

GSRx builds off of SiteWise™ and allows for a flexible, detailed analysis, particularly for materials and equipment use. GSRx was used to account for materials and activities not readily input into SiteWise™ and where equipment usage assumptions built into SiteWise™ were not consistent with site-specific requirements.

5.4.4 Environmental Footprint Evaluation Framework and Limitations

The environmental footprint evaluation performed for Site 4 considered life-cycle quantitative metrics for global warming potential (through greenhouse gas emissions), criteria air pollutant emissions (through NO_x, SO_x and PM₁₀ emissions), energy consumption, water usage, and worker safety.

Life cycle impacts were calculated for energy consumption, emissions of GHGs (carbon dioxide [CO₂], methane [CH₄], and nitrous oxide [N₂O]) and criteria pollutants (nitrogen oxides [NO_x], sulfur oxides [SO_x] and particulate matter [PM₁₀]), water usage, and energy consumption, and worker safety.

Life cycle inventory inputs in SiteWise™ were divided into four categories – 1) materials production; 2) transportation of personnel, materials and equipment; 3) equipment use and miscellaneous; and 4) residual handling and disposal. Cost estimates and design calculations were used as a basis for inventory quantities and related assumptions. Emission factors, energy consumption, and water usage data were correlated to material quantities, equipment, transportation distances, and installation time frames in order to calculate life-cycle emissions, energy consumption, water usage, and worker safety. Default SiteWise™ emission, energy usage, water consumption, and worker fatality and accident risk factors were utilized.

Although GSRx was used to minimize limitations resulting within SiteWise™, elimination of all limitations was not possible while using a hybrid model of SiteWise™ and GSRx. For example, several materials and construction equipment inventoried were input into GSRx and these impacts were incorporated into SiteWise™ within the “Equipment Use and Miscellaneous” sector. This sector in SiteWise™ does not differentiate into the specific equipment usage or material consumption items that are input in GSRx, but rather are considered miscellaneous items. However, impact drivers for items input in GSRx can be identified and evaluated directly within the respective GSRx evaluation and output summary sheets. In addition, worker safety results in general do not include worker safety related to equipment usage that was input within GSRx because GSRx was not developed to evaluate worker safety.

5.4.5 Evaluation Results

The following are the alternatives that were analyzed with SiteWise™ and GSRx:

- Alternative 2: Monitored Natural Attenuation and Land Use Controls
- Alternative 3: Steam Injection and Free Product Recovery
- Alternative 4: Biosparging with Steam Injection and Free Product Recovery
- Alternative 5: Solvent Extraction and Free Product Recovery with Biosparging
- Alternative 6A: Excavation and Disposal of Soils (Soil TPH greater than 1,000 mg/Kg)
- Alternative 6B: Excavation and Disposal of Soils (Soil TPH greater than 10,000 mg/Kg)

The following sections summarize the relative environmental impacts and primary impact drivers for the six alternatives and their respective metrics. Appendix E includes the inventory and output sheets that were used for the SiteWise™/GSRx hybrid model. An evaluation of SiteWise™ and GSRx output summary sheets and related figures are included in the footprint evaluation attachments (Appendix E), provides detailed information on the contribution to each metric from each phase of the remedial process (RI, RAC, RAO, and LTM) and for each respective input category (materials production, transportation, equipment usage, etc). Further inspection of related inventory sheets provide information on the specific contribution to a metric from each item of material, transportation, equipment, etc. This level of detail also helps clarify results that could be misinterpreted based on SiteWise™ data entry limitations mentioned previously. The environmental impacts of the alternatives analyzed are summarized quantitatively in Appendix E (Table E1).

Greenhouse Gas Emissions

Emissions of CO₂, CH₄, and N₂O were normalized to CO₂ equivalents (CO₂e), which is a cumulative method of weighing GHG emissions relative to global warming potential. Exhibit 1 shows the overall GHG emissions of each of the alternatives analyzed; the x-axis represents the six alternatives evaluated and the y-axis represents the GHG emissions in metric ton of CO₂e.

Exhibit 1: GHG Emissions

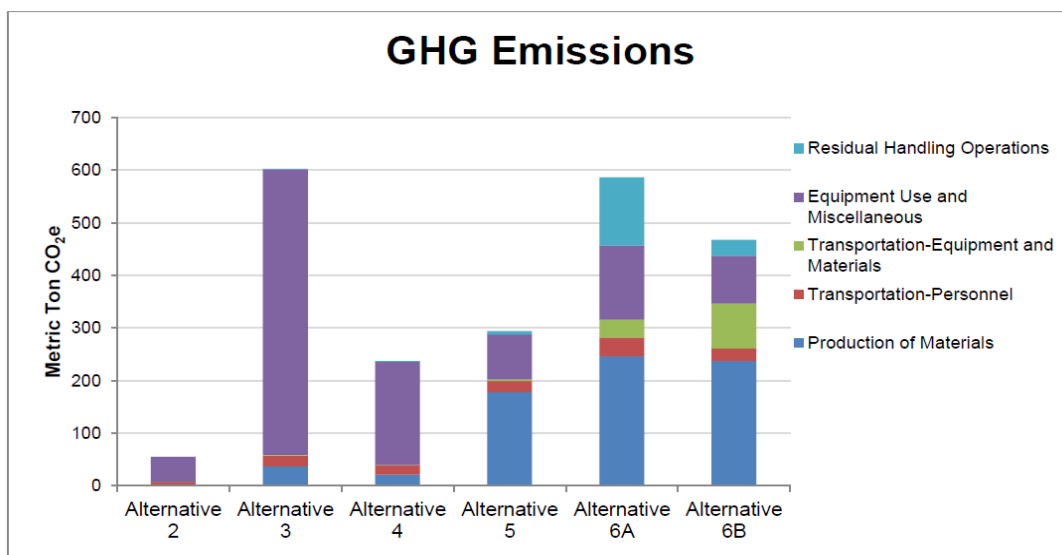

Criteria Pollutant Emissions – NO_x

Exhibit 2 shows the overall NO_x emissions of each of the alternatives analyzed; the x-axis represents the six alternatives evaluated and the y-axis represents the NO_x emissions in metric ton of NO_x.

Exhibit 2: NO_x Emissions

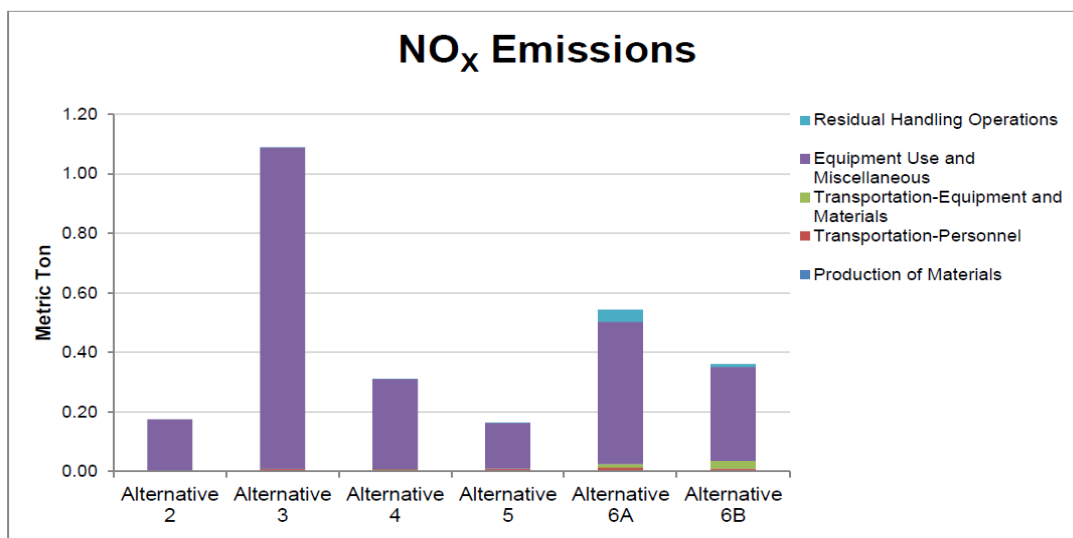

Criteria Pollutant Emissions – SO_x

Exhibit 3 shows the overall SO_x emissions of each of the alternatives analyzed; the x-axis represents the six alternatives evaluated and the y-axis represents the SO_x emissions in metric ton of SO_x.

Exhibit 3: SO_x Emissions

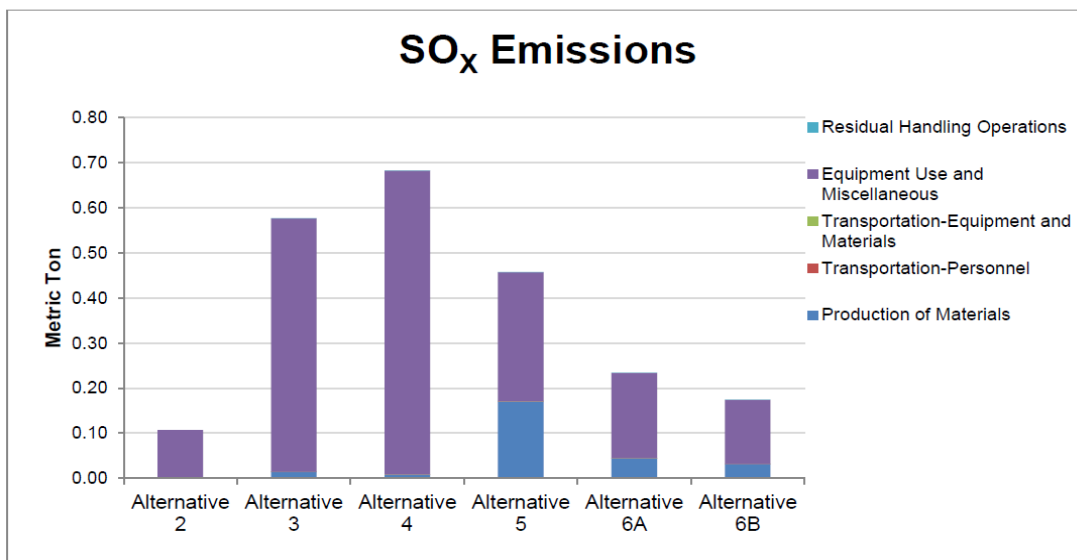

Criteria Pollutant Emissions – PM₁₀

Exhibit 4 shows the overall PM₁₀ emissions of each of the alternatives analyzed; the x-axis represents the six alternatives evaluated and the y-axis represents the PM₁₀ emissions in metric ton of PM₁₀.

Exhibit 4: PM₁₀ Emissions

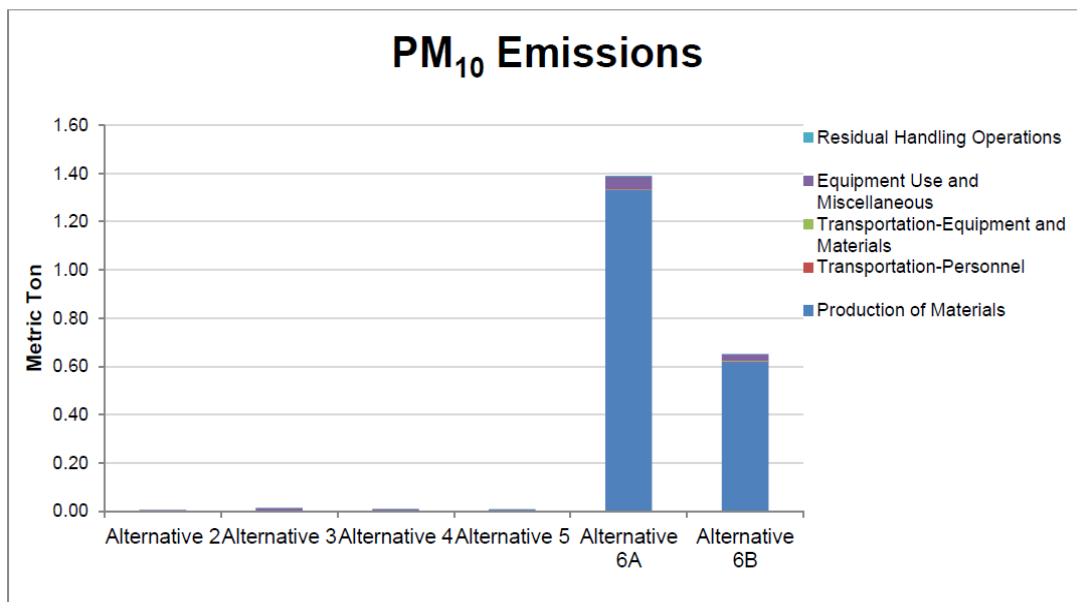

5.4.6 Energy Consumption

Exhibit 5 shows the energy consumption of each of the alternatives analyzed; the x-axis represents the six alternatives evaluated and the y-axis represents the amount of energy consumed in units of million British Thermal Units (MMBTU).

Exhibit 5: Energy Consumption

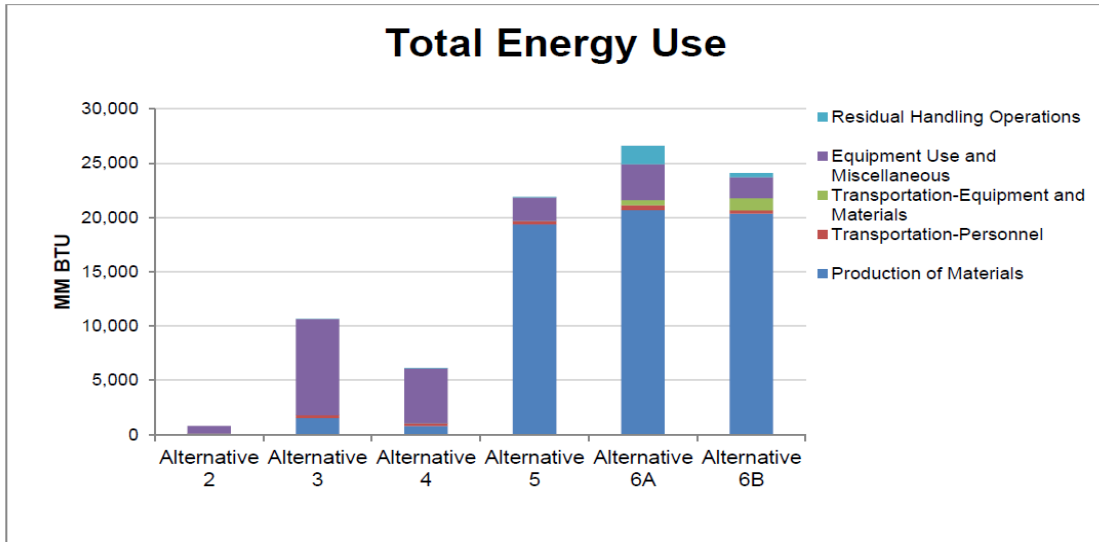

5.4.7 Water Usage

The water consumption of the evaluated alternatives is shown in Exhibit 6. The x-axis shows the six evaluated alternatives, and the y-axis show the amount of water consumed in thousands of gallons.

Exhibit 6: Water Consumption

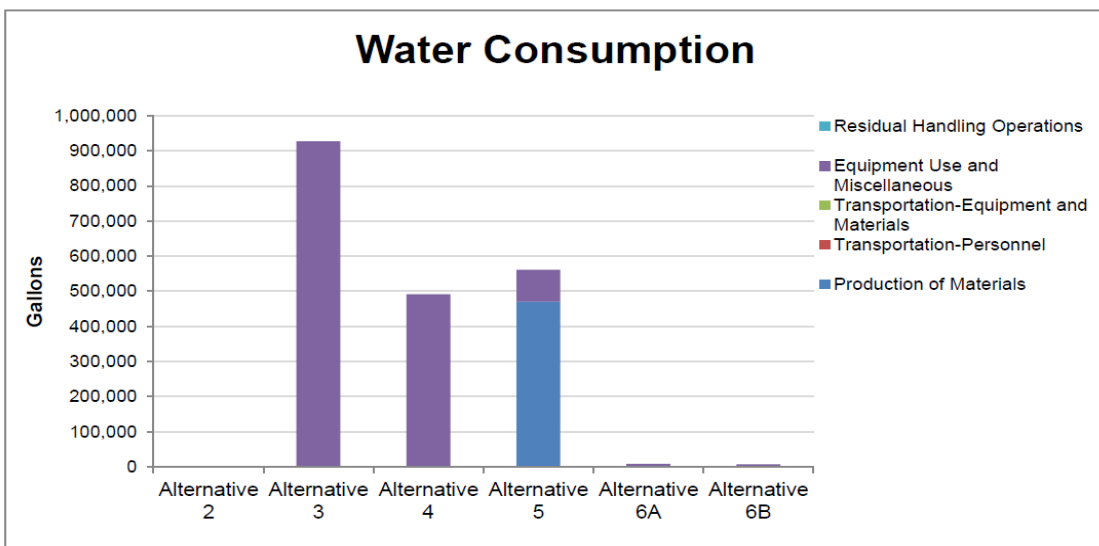

5.4.8 Accident Risk - Fatality

Exhibit 7 shows the risk of fatality between the evaluated alternatives. The x-axis represents the six alternatives evaluated, and the y-axis represents the risk of fatality.

Exhibit 7: Risk of Fatality

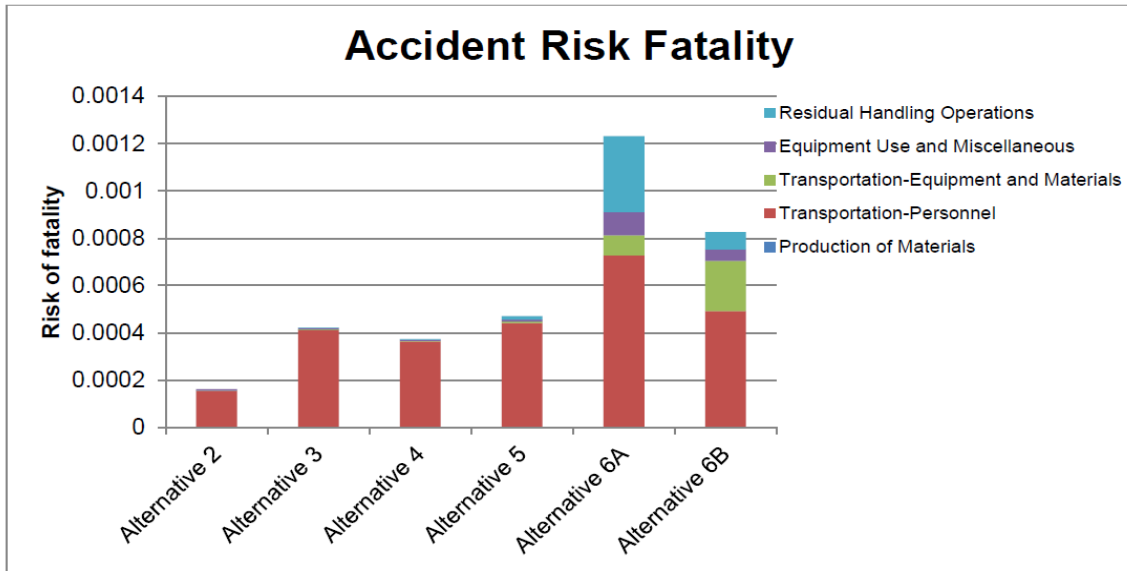

Accident Risk - Injury

Exhibit 8 shows the risk of injury between the evaluated alternatives. The x-axis represents the six alternatives evaluated, and the y-axis represents the risk of injury.

Exhibit 8: Risk of Injury

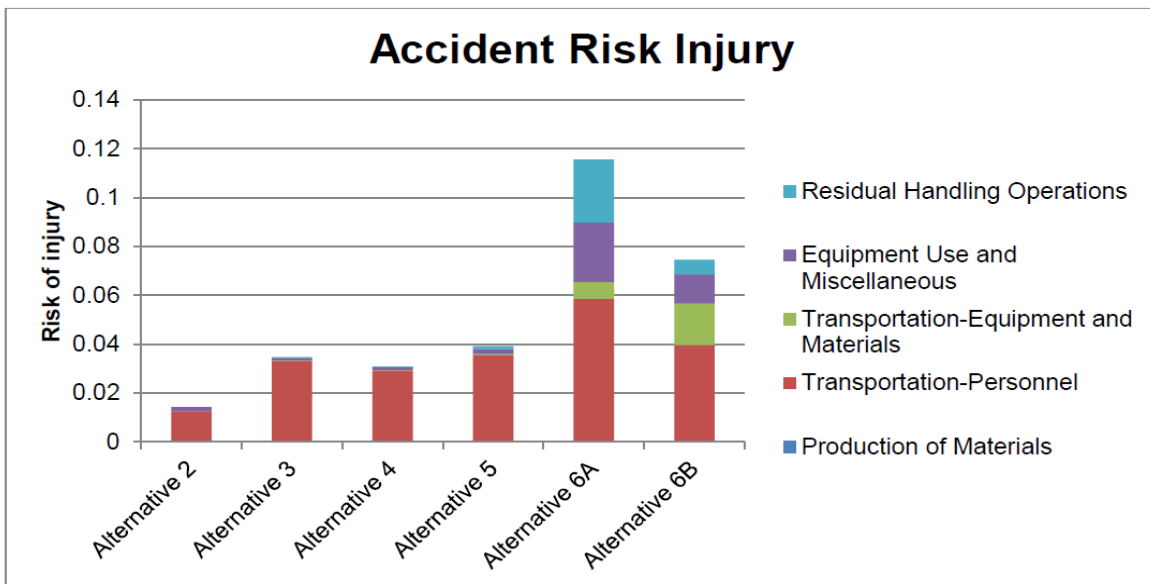

5.4.9 Conclusions and Recommendations

During selection and design of the remedy, a sensitivity analysis considering elements of the remedy that have the greatest impact on remedy effectiveness, life-cycle cost, and environmental footprint metrics may provide additional insight into appropriate optimization. To aid in the sensitivity analysis, an impact analysis summary was created to qualitatively highlight the relative impact of respective metrics for the two alternatives and to identify the primary drivers of emissions, energy consumption, and water usage for each alternative (see Table E2 in Appendix E for details).

An evaluation was conducted to identify the sector whose contribution is largest to that impact category (Appendix E). Identifying where the large contributions occur optimizes the process for potentially lowering the environmental impacts of each of the alternatives evaluated. Considering this, the following recommendations could noticeably reduce the environmental footprint of the alternatives are listed below.

- Alternative 2: Consider further optimization and reducing the number of samples analyzed as the laboratory analytical services are the major driver in most of the impact categories.
- Alternative 3: Consider further optimization and reducing the use of steam injection during the treatment stage. The environmental impact of electricity production for steam injection has the most influence in most of the impact categories evaluated.
- Alternative 4: Consider further optimization and reducing the use of steam and air injection activities during the treatment stage. The environmental impact of electricity production for steam and air injection activities has the most influence in most of the impact categories evaluated.
- Alternative 5: Consider if the volume of Vertec used during the treatment stage could be reduced. Reducing the volume would significantly reduce the amount of GHG, NO_x, SO_x and PM₁₀ emissions released to the atmosphere as well as the amount of energy utilized.
- Alternatives 6A and 6B: Consider alternative means to acquire clean backfill. Acquiring clean fill that has been processed off-site is the major contributor in the impact categories of GHG and energy utilized for both of these alternatives.
- All Alternatives: Optimize the number of samples analyzed as the laboratory analytical services are one of the major drivers in some of the impact categories.
- All Alternatives: Consider ways to reduce vehicle mileage to reduce worker risk as well as energy use and emissions. Encourage site workers to carpool daily to the site to reduce total vehicle mileage.
- All Alternatives: Some reduction of the environmental footprint, particularly GHG emissions and energy consumption, could be realized for all alternatives through the possible use of emission control measures such as alternate fuel sources (e.g. biodiesel), equipment exhaust controls (e.g. diesel), and equipment idle reduction.

REFERENCES

EPA (U.S. Environmental Protection Agency), 1988. *Guidance for Conducting Remedial Investigations and Feasibility Studies Under CERCLA*.

EPA (US Environmental Protection Agency), 2012. *Regional Screening Levels (Updated April 2012)*. http://www.epa.gov/reg3hwmd/risk/human/rb-concentration_table/Generic_Tables/index.htm. Accessed May 2012.

Fetter, C.W., 1994. *Applied Hydrogeology*. New Jersey, page 98.

NAVFAC, 2010a. *Department of Navy Policy on SiteWise™ Optimization/GSR Tool Usage*. Email communication from Mr. Brian Harrison, NAVFAC Headquarters. 10 August 2010.

NAVFAC, 2010b. DON Guidance for Optimizing Remedy Evaluation, Selection, and Design, March 2010

NYSDEC (New York State Department of Environmental Conservation), 1992. Petroleum-Contaminated Soil Guidance Policy Spill Technology and Remediation Series (STARS) Memo #1. August.

Tetra Tech NUS, 2003. RCRA Facility Assessment/Focused Feasibility Study for the Former Underground Storage Tanks Plant No. 3 Area of Concern 22. Revision 1. January.

Tetra Tech NUS, 2007. Soil and Groundwater Report in Support of Closed Loop Bioreactor Pilot-Scale Study, for AOC 22, Site 4, Former Underground Storage Tanks, Naval Weapons Industrial Reserve Plant (NWIRP) Bethpage, New York, September.

New York State Department of Health (NYSDOH) Maximum Contaminant Level (MCL). 10 NYCRR, Part 5, Subpart 5-1 Public Water Systems, Tables 1 through 3. http://www.health.ny.gov/regulations/nycrr/title_10/part_5/subpart_5-1_tables.htm#table1.

TABLE 2-1
ANALYTICAL DETECTIONS IN SITE SOILS
SITE 4 (AOC 22)
NWIRP BETHPAGE, NEW YORK
Page 1 of 8

Location:	EPA Risk-based SSL for the Protection of Groundwater ⁽¹⁾	EPA RSL for Residential Exposure Through Direct Contact ⁽²⁾	NYSDEC Unrestricted Use Soil Cleanup Objectives ⁽³⁾	NYSDEC Soil Cleanup Objectives (Protection of Groundwater) ⁽⁴⁾	SB101	SB101	SB101	SB101	SB101	SB101	SB101	SB101	SB101
Sample Date:					12/14/2006	12/14/2006	12/14/2006	12/17/2004	12/14/2006	6/3/1999	8/23/2004	3/9/2005	5/18/2005
Top Depth (feet):					19	29	39	45	49	54	59	59	59
Bottom Depth (feet):					21	31	41	47	51	56	61	61	61
ORGANICS (mg/kg)													
Petroleum Hydrocarbons ⁽⁵⁾	NE	NE	NE	NE		14,000	5,800	5,700	36,000	1,978	6,900	18,000	33,000
SEMIVOLATILES (µg/kg)													
2,4-Dimethylphenol	320	1,200,000	NE	NE	NS	NS	NS	220 J	NS				
2-Methylnaphthalene	140	230,000	NE	NE		NS	NS				38,000 J	33,000	20,000 J
Acenaphthene	4,100	3,400,000	20,000	98,000		NS	NS				2,100 J	1,300 J	
Anthracene	42,000	17,000,000	100,000	1,000,000		NS	NS					1,800 J	
Benz(a)anthracene	10	150	1,000	1,000		NS	NS				2,500 J	1,900 J	3,000 J
Benzo(a)pyrene	3.5	15	1,000	22,000		NS	NS		1,500 J			600 J	
Benzo(b)fluoranthene	35	150	1,000	1,700		NS	NS	260 J				3,300 J	
Benzo(g,h,i)perylene	NE	NE	100,000	1,000,000		NS	NS		1,400 J				
Benzo(k)fluoranthene	350	1,500	800	1,700		NS	NS						
Bis(2-ethylhexyl)phthalate ⁽⁶⁾	17	35,000	NE	NE	NS	NS	NS		NS				
Chrysene	1,100	15,000	1,000	1,000		NS	NS	620 J			3,700 J	4,100 J	5,200 J
Fluoranthene	70,000	2,300,000	100,000	1,000,000		NS	NS					1,500 J	
Fluorene	4,000	2,300,000	30,000	386,000		NS	NS				2,300 J	8,400	
Indeno(1,2,3-cd)pyrene	120	150	500	8,200		NS	NS						
Naphthalene	0.47	3,600	12,000	12,000		NS	NS				6,700 J	4,000 J	
Phenanthrene	NE	NE	100,000	1,000,000		NS	NS			3,000 J	15,000 J	11,000	12,000 J
Pyrene	9,500	1,700,000	100,000	1,000,000		NS	NS	1,400 J	12,000 J		9,400 J	13,000 J	8,900 J

Notes:

mg/kg -- milligrams per kilogram blank value - not detected
µg/kg -- micrograms per kilogram NS - not sampled
J - estimated value NE - Not established

Bold cell - exceedance of Environmental Protection Agency (EPA) Regional Screening Level (RSL's or SSL's)

Shaded cell - exceedance of New York State Department of Environmental Conservation (NYSDEC) Soil Cleanup Objective

1 - EPA SSL's Soil to Groundwater Supporting Table, April 2012. http://www.epa.gov/reg3hwmd/risk/human/rb-concentration_table/Generic_Tables/pdf/ressoil_sl_table_run_MAY2012.pdf. The SSL was based on a Carcinogenic Target Risk (TR) of 1E-06 and a Noncancer Hazard Index of 1.

2 - EPA RSL's Residential Soil Table, April 2012. http://www.epa.gov/reg3hwmd/risk/human/rb-concentration_table/Generic_Tables/pdf/ressoil_sl_table_run_MAY2012.pdf. The RSL for direct contact with soils was used for the pathways of ingestion, dermal contact, and inhalation. Values are based on a Carcinogenic Target Risk (TR) of 1E-06 and a Noncancer Hazard Index of 1.

3 - NYSDEC Subpart 375-6: Remedial Program Soil Cleanup Objectives, Table 375-6.8(a): Unrestricted Use Soil Cleanup Objectives. <http://www.dec.ny.gov/regs/15507.html#15513>.

4 - NYSDEC Subpart 375-6: Remedial Program Soil Cleanup Objectives, Table 375-6.8(b): Restricted Use Soil Cleanup Objectives for the Protection of Groundwater. <http://www.dec.ny.gov/regs/15507.html#15513>.

5 - For data collected during years 2004 to 2006, petroleum hydrocarbons are the sum of Diesel Range Organics (TPH-DRO) and extractable hydrocarbons. For 1999 and 2010 data, petroleum hydrocarbons are the sum of TPH-DRO, and Gasoline Range Organics (TPH-GRO).

6 - Bis(2-ethylhexyl)phthalate is a known laboratory contaminant, therefore this chemical will not be considered as a contaminant of potential concern.

TABLE 2-1
ANALYTICAL DETECTIONS IN SITE SOILS
SITE 4 (AOC 22)
NWIRP BETHPAGE, NEW YORK
Page 2 of 8

Location:	EPA Risk-based SSL for the Protection of Groundwater ⁽¹⁾	EPA RSL for Residential Exposure Through Direct Contact ⁽²⁾	NYSDEC Unrestricted Use Soil Cleanup Objectives ⁽³⁾	NYSDEC Soil Cleanup Objectives (Protection of Groundwater) ⁽⁴⁾	SB101	SB101	SB102	SB102	SB102	SB102	SB102	SB102	SB102
Sample Date:					12/14/2006	12/14/2006	12/15/2006	12/15/2006	12/15/2006	12/16/2004	8/23/2004	5/17/2005	12/15/2006
Top Depth (feet):					59	69	19	29	39	40	49	49	49
Bottom Depth (feet):					61	71	21	31	41	42	51	51	51
ORGANICS (mg/kg)													
Petroleum Hydrocarbons ⁽⁵⁾	NE	NE	NE	NE	25,000	38	14	14,000	5,800	750	5,600	2,100	5,300
SEMIVOLATILES (µg/kg)													
2,4-Dimethylphenol	320	1,200,000	NE	NE	NS	NS	NS	NS	NS				NS
2-Methylnaphthalene	140	230,000	NE	NE	NS			NS	NS		950 J		
Acenaphthene	4,100	3,400,000	20,000	98,000	NS			NS	NS		850 J		
Anthracene	42,000	17,000,000	100,000	1,000,000	NS			NS	NS		890 J		
Benz(a)anthracene	10	150	1,000	1,000	NS			NS	NS		710 J		
Benzo(a)pyrene	3.5	15	1,000	22,000	NS			NS	NS				
Benzo(b)fluoranthene	35	150	1,000	1,700	NS			NS	NS				
Benzo(g,h,i)perylene	NE	NE	100,000	1,000,000	NS			NS	NS	320 J		330 J	
Benzo(k)fluoranthene	350	1,500	800	1,700	NS			NS	NS				
Bis(2-ethylhexyl)phthalate ⁽⁶⁾	17	35,000	NE	NE	NS	NS	NS	NS	NS	240 J			NS
Chrysene	1,100	15,000	1,000	1,000	NS			NS	NS		1,300 J		1,000 J
Fluoranthene	70,000	2,300,000	100,000	1,000,000	NS			NS	NS				
Fluorene	4,000	2,300,000	30,000	386,000	NS			NS	NS		1,100 J		
Indeno(1,2,3-cd)pyrene	120	150	500	8,200	NS			NS	NS				
Naphthalene	0.47	3,600	12,000	12,000	NS			NS	NS				
Phenanthrene	NE	NE	100,000	1,000,000	NS			NS	NS		4,700 J		
Pyrene	9,500	1,700,000	100,000	1,000,000	NS			NS	NS	170 J	2,900 J	340 J	3,900 J

Notes:

mg/kg -- milligrams per kilogram blank value - not detected

µg/kg -- micrograms per kilogram NS - not sampled

J - estimated value NE - Not established

Bold cell - exceedance of Environmental Protection Agency (EPA) Regional Screening Level (RSL's or SSL's)

Shaded cell - exceedance of New York State Department of Environmental Conservation (NYSDEC) Soil Cleanup Objective

1 - EPA SSL's Soil to Groundwater Supporting Table, April 2012. http://www.epa.gov/reg3hwmd/risk/human/rb-concentration_table/Generic_Tables/pdf/ressoil_sl_table_run_MAY2012.pdf. The SSL was based on a Carcinogenic Target Risk (TR) of 1E-06 and a Noncancer Hazard Index of 1.

2 - EPA RSL's Residential Soil Table, April 2012. http://www.epa.gov/reg3hwmd/risk/human/rb-concentration_table/Generic_Tables/pdf/ressoil_sl_table_run_MAY2012.pdf. The RSL for direct contact with soils was used for the pathways of ingestion, dermal contact, and inhalation. Values are based on a Carcinogenic Target Risk (TR) of 1E-06 and a Noncancer Hazard Index of 1.

3 - NYSDEC Subpart 375-6: Remedial Program Soil Cleanup Objectives, Table 375-6.8(a): Unrestricted Use Soil Cleanup Objectives. <http://www.dec.ny.gov/regs/15507.html#15513>.

4 - NYSDEC Subpart 375-6: Remedial Program Soil Cleanup Objectives, Table 375-6.8(b): Restricted Use Soil Cleanup Objectives for the Protection of Groundwater. <http://www.dec.ny.gov/regs/15507.html#15513>.

5 - For data collected during years 2004 to 2006, petroleum hydrocarbons are the sum of Diesel Range Organics (TPH-DRO) and extractable hydrocarbons. For 1999 and 2010 data, petroleum hydrocarbons are the sum of TPH-DRO, and Gasoline Range Organics (TPH-GRO).

6 - Bis(2-ethylhexyl)phthalate is a known laboratory contaminant, therefore this chemical will not be considered as a contaminant of potential concern.

TABLE 2-1
ANALYTICAL DETECTIONS IN SITE SOILS
SITE 4 (AOC 22)
NWIRP BETHPAGE, NEW YORK
Page 3 of 8

Location:	EPA Risk-based SSL for the Protection of Groundwater ⁽¹⁾	EPA RSL for Residential Exposure Through Direct Contact ⁽²⁾	NYSDEC Unrestricted Use Soil Cleanup Objectives ⁽³⁾	NYSDEC Soil Cleanup Objectives (Protection of Groundwater) ⁽⁴⁾	SB102	SB102	SB102	SB102	SB103	SB103	SB103	SB103	SB103
Sample Date:					6/7/1999	3/9/2005	12/15/2006	12/15/2006	12/13/2006	12/13/2006	12/13/2006	12/15/2004	12/13/2006
Top Depth (feet):					57	59	59	69	19	29	39	40	49
Bottom Depth (feet):					59	61	61	71	21	31	41	42	51
ORGANICS (mg/kg)													
Petroleum Hydrocarbons ⁽⁵⁾	NE	NE	NE	NE	21,300	50,000	16,000	125	2,100	2,400	6,100	5,300	6,100
SEMIVOLATILES (µg/kg)													
2,4-Dimethylphenol	320	1,200,000	NE	NE	NS		NS	NS	NS	NS	NS	300 J	NS
2-Methylnaphthalene	140	230,000	NE	NE	NS	49,000	NS			NS	NS		
Acenaphthene	4,100	3,400,000	20,000	98,000	NS	4,200 J	NS			NS	NS		
Anthracene	42,000	17,000,000	100,000	1,000,000	NS	4,800 J	NS			NS	NS		
Benz(a)anthracene	10	150	1,000	1,000	NS	3,100 J	NS			NS	NS	540 J	
Benzo(a)pyrene	3.5	15	1,000	22,000	NS	1,900 J	NS			NS	NS	520 J	560 J
Benzo(b)fluoranthene	35	150	1,000	1,700	NS		NS			NS	NS	350 J	
Benzo(g,h,i)perylene	NE	NE	100,000	1,000,000	NS	1,100 J	NS			NS	NS	410 J	
Benzo(k)fluoranthene	350	1,500	800	1,700	NS		NS			NS	NS		
Bis(2-ethylhexyl)phthalate ⁽⁶⁾	17	35,000	NE	NE	NS		NS	NS	NS	NS	NS		NS
Chrysene	1,100	15,000	1,000	1,000	NS	7,300 J	NS			NS	NS	1,100 J	
Fluoranthene	70,000	2,300,000	100,000	1,000,000	NS	2,600 J	NS			NS	NS	200 J	
Fluorene	4,000	2,300,000	30,000	386,000	NS	22,000	NS			NS	NS		
Indeno(1,2,3-cd)pyrene	120	150	500	8,200	NS		NS			NS	NS		
Naphthalene	0.47	3,600	12,000	12,000	NS	9,400 J	NS			NS	NS		
Phenanthrene	NE	NE	100,000	1,000,000	NS	23,000	NS			NS	NS		
Pyrene	9,500	1,700,000	100,000	1,000,000	NS	33,000	NS			NS	NS	3,800 J	2,800 J

Notes:

mg/kg -- milligrams per kilogram blank value - not detected
µg/kg -- micrograms per kilogram NS - not sampled
J - estimated value NE - Not established

Bold cell - exceedance of Environmental Protection Agency (EPA) Regional Screening Level (RSL's or SSL's)

Shaded cell - exceedance of New York State Department of Environmental Conservation (NYSDEC) Soil Cleanup Objective

1 - EPA SSL's Soil to Groundwater Supporting Table, April 2012. http://www.epa.gov/reg3hwmd/risk/human/rb-concentration_table/Generic_Tables/pdf/ressoil_sl_table_run_MAY2012.pdf. The SSL was based on a Carcinogenic Target Risk (TR) of 1E-06 and a Noncancer Hazard Index of 1.

2 - EPA RSL's Residential Soil Table, April 2012. http://www.epa.gov/reg3hwmd/risk/human/rb-concentration_table/Generic_Tables/pdf/ressoil_sl_table_run_MAY2012.pdf. The RSL for direct contact with soils was used for the pathways of ingestion, dermal contact, and inhalation. Values are based on a Carcinogenic Target Risk (TR) of 1E-06 and a Noncancer Hazard Index of 1.

3 - NYSDEC Subpart 375-6: Remedial Program Soil Cleanup Objectives, Table 375-6.8(a): Unrestricted Use Soil Cleanup Objectives. <http://www.dec.ny.gov/regs/15507.html#15513>.

4 - NYSDEC Subpart 375-6: Remedial Program Soil Cleanup Objectives, Table 375-6.8(b): Restricted Use Soil Cleanup Objectives for the Protection of Groundwater. <http://www.dec.ny.gov/regs/15507.html#15513>.

5 - For data collected during years 2004 to 2006, petroleum hydrocarbons are the sum of Diesel Range Organics (TPH-DRO) and extractable hydrocarbons. For 1999 and 2010 data, petroleum hydrocarbons are the sum of TPH-DRO, and Gasoline Range Organics (TPH-GRO).

6 - Bis(2-ethylhexyl)phthalate is a known laboratory contaminant, therefore this chemical will not be considered as a contaminant of potential concern.

TABLE 2-1
ANALYTICAL DETECTIONS IN SITE SOILS
SITE 4 (AOC 22)
NWIRP BETHPAGE, NEW YORK
Page 4 of 8

Location:	EPA Risk-based SSL for the Protection of Groundwater ⁽¹⁾	EPA RSL for Residential Exposure Through Direct Contact ⁽²⁾	NYSDEC Unrestricted Use Soil Cleanup Objectives ⁽³⁾	NYSDEC Soil Cleanup Objectives (Protection of Groundwater) ⁽⁴⁾	SB103	SB103	SB103	SB103	SB103	SB103	SB104	SB104	SB104
Sample Date:					6/8/1999	8/23/2004	3/9/2005	5/17/2005	12/13/2006	12/13/2006	12/14/2006	12/14/2006	12/14/2006
Top Depth (feet):					55	59	59	59	59	66	19	29	39
Bottom Depth (feet):					57	61	61	61	61	68	21	31	41
ORGANICS (mg/kg)													
Petroleum Hydrocarbons ⁽⁵⁾	NE	NE	NE	NE	13,140	10,000	21,000	24,000	23,000	2,600	1,500	630	435 J
SEMIVOLATILES (µg/kg)													
2,4-Dimethylphenol	320	1,200,000	NE	NE	NS				NS	NS	NS	NS	NS
2-Methylnaphthalene	140	230,000	NE	NE	NS	51,000 J	68,000 J	73,000	NS	1,000		NS	NS
Acenaphthene	4,100	3,400,000	20,000	98,000	NS	4,400 J	6,300 J	6,400 J	NS	170 J		NS	NS
Anthracene	42,000	17,000,000	100,000	1,000,000	NS	4,600 J	7,500 J	8,400 J	NS	280 J		NS	NS
Benz(a)anthracene	10	150	1,000	1,000	NS	3,500 J	4,200 J		NS	230 J		NS	NS
Benzo(a)pyrene	3.5	15	1,000	22,000	NS		2,700 J		NS	130 J		NS	NS
Benzo(b)fluoranthene	35	150	1,000	1,700	NS				NS			NS	NS
Benzo(g,h,i)perylene	NE	NE	100,000	1,000,000	NS				NS			NS	NS
Benzo(k)fluoranthene	350	1,500	800	1,700	NS				NS			NS	NS
Bis(2-ethylhexyl)phthalate ⁽⁶⁾	17	35,000	NE	NE	NS				NS	NS	NS	NS	NS
Chrysene	1,100	15,000	1,000	1,000	NS	4,000 J	8,600 J	8,600 J	NS	430 J		NS	NS
Fluoranthene	70,000	2,300,000	100,000	1,000,000	NS		3,400 J		NS			NS	NS
Fluorene	4,000	2,300,000	30,000	386,000	NS	4,800 J	25,000 J	9,500 J	NS	350 J		NS	NS
Indeno(1,2,3-cd)pyrene	120	150	500	8,200	NS				NS			NS	NS
Naphthalene	0.47	3,600	12,000	12,000	NS	11,000 J	13,000 J	15,000 J	NS	87 J		NS	NS
Phenanthrene	NE	NE	100,000	1,000,000	NS	22,000 J	33,000	39,000 J	NS	1,300		NS	NS
Pyrene	9,500	1,700,000	100,000	1,000,000	NS	18,000 J	36,000	28,000 J	NS	1,400 J		NS	NS

Notes:

mg/kg -- milligrams per kilogram blank value - not detected

µg/kg -- micrograms per kilogram NS - not sampled

J - estimated value NE - Not established

Bold cell - exceedance of Environmental Protection Agency (EPA) Regional Screening Level (RSL's or SSL's)

Shaded cell - exceedance of New York State Department of Environmental Conservation (NYSDEC) Soil Cleanup Objective

1 - EPA SSL's Soil to Groundwater Supporting Table, April 2012. http://www.epa.gov/reg3hwmd/risk/human/rb-concentration_table/Generic_Tables/pdf/ressoil_sl_table_run_MAY2012.pdf. The SSL was based on a Carcinogenic Target Risk (TR) of 1E-06 and a Noncancer Hazard Index of 1.

2 - EPA RSL's Residential Soil Table, April 2012. http://www.epa.gov/reg3hwmd/risk/human/rb-concentration_table/Generic_Tables/pdf/ressoil_sl_table_run_MAY2012.pdf. The RSL for direct contact with soils was used for the pathways of ingestion, dermal contact, and inhalation. Values are based on a Carcinogenic Target Risk (TR) of 1E-06 and a Noncancer Hazard Index of 1.

3 - NYSDEC Subpart 375-6: Remedial Program Soil Cleanup Objectives, Table 375-6.8(a): Unrestricted Use Soil Cleanup Objectives. <http://www.dec.ny.gov/regs/15507.html#15513>.

4 - NYSDEC Subpart 375-6: Remedial Program Soil Cleanup Objectives, Table 375-6.8(b): Restricted Use Soil Cleanup Objectives for the Protection of Groundwater. <http://www.dec.ny.gov/regs/15507.html#15513>.

5 - For data collected during years 2004 to 2006, petroleum hydrocarbons are the sum of Diesel Range Organics (TPH-DRO) and extractable hydrocarbons. For 1999 and 2010 data, petroleum hydrocarbons are the sum of TPH-DRO, and Gasoline Range Organics (TPH-GRO).

6 - Bis(2-ethylhexyl)phthalate is a known laboratory contaminant, therefore this chemical will not be considered as a contaminant of potential concern.

TABLE 2-1
ANALYTICAL DETECTIONS IN SITE SOILS
SITE 4 (AOC 22)
NWIRP BETHPAGE, NEW YORK
Page 5 of 8

Location:	EPA Risk-based SSL for the Protection of Groundwater ⁽¹⁾	EPA RSL for Residential Exposure Through Direct Contact ⁽²⁾	NYSDEC Unrestricted Use Soil Cleanup Objectives ⁽³⁾	NYSDEC Soil Cleanup Objectives (Protection of Groundwater) ⁽⁴⁾	SB104	SB104	SB104	SB104	SB104	SB104	SB104	SB104	SB105
Sample Date:					8/23/2004	12/15/2004	3/8/2005	5/17/2005	12/14/2006	6/9/1999	12/14/2006	12/14/2006	6/22/1999
Top Depth (feet):					49	50	49	49	49	57	59	69	55
Bottom Depth (feet):					51	51	51	51	51	59	61	71	59
ORGANICS (mg/kg)													
Petroleum Hydrocarbons ⁽⁵⁾	NE	NE	NE	NE	1,800	2,800	4,900	3,100	1,600	12,250	750	5,100	5,444
SEMIVOLATILES (µg/kg)													
2,4-Dimethylphenol	320	1,200,000	NE	NE					NS	NS	NS	NS	
2-Methylnaphthalene	140	230,000	NE	NE	180 J	250 J	120 J			NS	NS		3,200
Acenaphthene	4,100	3,400,000	20,000	98,000	330 J	720 J				NS	NS		
Anthracene	42,000	17,000,000	100,000	1,000,000	380 J	420 J				NS	NS		
Benz(a)anthracene	10	150	1,000	1,000	380 J	550 J	1,400 J	380 J		NS	NS	720 J	
Benzo(a)pyrene	3.5	15	1,000	22,000		310 J	1,000 J	300 J		NS	NS		
Benzo(b)fluoranthene	35	150	1,000	1,700		190 J	2,400 J			NS	NS		
Benzo(g,h,i)perylene	NE	NE	100,000	1,000,000		310 J	290 J			NS	NS		
Benzo(k)fluoranthene	350	1,500	800	1,700			150 J			NS	NS		
Bis(2-ethylhexyl)phthalate ⁽⁶⁾	17	35,000	NE	NE			320 J		NS	NS	NS	NS	
Chrysene	1,100	15,000	1,000	1,000	520 J	980 J	2,600 J	440 J		NS	NS	1,200 J	
Fluoranthene	70,000	2,300,000	100,000	1,000,000	210 J	450 J	1,600 J			NS	NS		
Fluorene	4,000	2,300,000	30,000	386,000	380 J	820 J	3,400 J			NS	NS		670 J
Indeno(1,2,3-cd)pyrene	120	150	500	8,200			200 J			NS	NS		
Naphthalene	0.47	3,600	12,000	12,000						NS	NS		
Phenanthrene	NE	NE	100,000	1,000,000	1,000 J	2,300 J	300 J			NS	NS	550 J	2,800
Pyrene	9,500	1,700,000	100,000	1,000,000	1,300 J	2,300 J	6,600	1,700 J		NS	NS	3,900	

Notes:

mg/kg -- milligrams per kilogram blank value - not detected
µg/kg -- micrograms per kilogram NS - not sampled
J - estimated value NE - Not established

Bold cell - exceedance of Environmental Protection Agency (EPA) Regional Screening Level (RSL's or SSL's)

Shaded cell - exceedance of New York State Department of Environmental Conservation (NYSDEC) Soil Cleanup Objective

1 - EPA SSL's Soil to Groundwater Supporting Table, April 2012. http://www.epa.gov/reg3hwmd/risk/human/rb-concentration_table/Generic_Tables/pdf/ressoil_sl_table_run_MAY2012.pdf. The SSL was based on a Carcinogenic Target Risk (TR) of 1E-06 and a Noncancer Hazard Index of 1.

2 - EPA RSL's Residential Soil Table, April 2012. http://www.epa.gov/reg3hwmd/risk/human/rb-concentration_table/Generic_Tables/pdf/ressoil_sl_table_run_MAY2012.pdf. The RSL for direct contact with soils was used for the pathways of ingestion, dermal contact, and inhalation. Values are based on a Carcinogenic Target Risk (TR) of 1E-06 and a Noncancer Hazard Index of 1.

3 - NYSDEC Subpart 375-6: Remedial Program Soil Cleanup Objectives, Table 375-6.8(a): Unrestricted Use Soil Cleanup Objectives. <http://www.dec.ny.gov/regs/15507.html#15513>.

4 - NYSDEC Subpart 375-6: Remedial Program Soil Cleanup Objectives, Table 375-6.8(b): Restricted Use Soil Cleanup Objectives for the Protection of Groundwater. <http://www.dec.ny.gov/regs/15507.html#15513>.

5 - For data collected during years 2004 to 2006, petroleum hydrocarbons are the sum of Diesel Range Organics (TPH-DRO) and extractable hydrocarbons. For 1999 and 2010 data, petroleum hydrocarbons are the sum of TPH-DRO, and Gasoline Range Organics (TPH-GRO).

6 - Bis(2-ethylhexyl)phthalate is a known laboratory contaminant, therefore this chemical will not be considered as a contaminant of potential concern.

**TABLE 2-1
ANALYTICAL DETECTIONS IN SITE SOILS
SITE 4 (AOC 22)
NWIRP BETHPAGE, NEW YORK
Page 6 of 8**

Location:	EPA Risk-based SSL for the Protection of Groundwater ⁽¹⁾	EPA RSL for Residential Exposure Through Direct Contact ⁽²⁾	NYSDEC Unrestricted Use Soil Cleanup Objectives ⁽³⁾	NYSDEC Soil Cleanup Objectives (Protection of Groundwater) ⁽⁴⁾	SB105	SB105	SB106	SB106	SB106	SB107	SB107	SB107	SB108
Sample Date:					12/12/2006	6/22/1999	12/13/2006	6/23/1999	12/13/2006	12/12/2006	12/12/2006	6/24/1999	12/11/2006
Top Depth (feet):					56	95	51	55	56	42	52	55	45
Bottom Depth (feet):					58	99	53	57	58	44	54	57	47
ORGANICS (mg/kg)													
Petroleum Hydrocarbons ⁽⁵⁾	NE	NE	NE	NE	3,400		1,700		3,600			1,323 J	95
SEMIVOLATILES (µg/kg)													
2,4-Dimethylphenol	320	1,200,000	NE	NE	NS		NS	NS	NS	NS	NS	NS	NS
2-Methylnaphthalene	140	230,000	NE	NE	NS	1,700 J	NS	NS	NS	NS	NS	NS	NS
Acenaphthene	4,100	3,400,000	20,000	98,000	NS		NS	NS	NS	NS	NS	NS	NS
Anthracene	42,000	17,000,000	100,000	1,000,000	NS		NS	NS	NS	NS	NS	NS	NS
Benz(a)anthracene	10	150	1,000	1,000	NS		NS	NS	NS	NS	NS	NS	NS
Benzo(a)pyrene	3.5	15	1,000	22,000	NS		NS	NS	NS	NS	NS	NS	NS
Benzo(b)fluoranthene	35	150	1,000	1,700	NS		NS	NS	NS	NS	NS	NS	NS
Benzo(g,h,i)perylene	NE	NE	100,000	1,000,000	NS		NS	NS	NS	NS	NS	NS	NS
Benzo(k)fluoranthene	350	1,500	800	1,700	NS		NS	NS	NS	NS	NS	NS	NS
Bis(2-ethylhexyl)phthalate ⁽⁶⁾	17	35,000	NE	NE	NS		NS	NS	NS	NS	NS	NS	NS
Chrysene	1,100	15,000	1,000	1,000	NS	980 J	NS	NS	NS	NS	NS	NS	NS
Fluoranthene	70,000	2,300,000	100,000	1,000,000	NS		NS	NS	NS	NS	NS	NS	NS
Fluorene	4,000	2,300,000	30,000	386,000	NS		NS	NS	NS	NS	NS	NS	NS
Indeno(1,2,3-cd)pyrene	120	150	500	8,200	NS		NS	NS	NS	NS	NS	NS	NS
Naphthalene	0.47	3,600	12,000	12,000	NS		NS	NS	NS	NS	NS	NS	NS
Phenanthrene	NE	NE	100,000	1,000,000	NS	2,500	NS	NS	NS	NS	NS	NS	NS
Pyrene	9,500	1,700,000	100,000	1,000,000	NS	2,300	NS	NS	NS	NS	NS	NS	NS

Notes:

mg/kg -- milligrams per kilogram blank value - not detected

µg/kg -- micrograms per kilogram NS - not sampled

J - estimated value NE - Not established

Bold cell - exceedance of Environmental Protection Agency (EPA) Regional Screening Level (RSL's or SSL's)

Shaded cell - exceedance of New York State Department of Environmental Conservation (NYSDEC) Soil Cleanup Objective

1 - EPA SSL's Soil to Groundwater Supporting Table, April 2012. http://www.epa.gov/reg3hwmd/risk/human/rb-concentration_table/Generic_Tables/pdf/ressoil_sl_table_run_MAY2012.pdf. The SSL was based on a Carcinogenic Target Risk (TR) of 1E-06 and a Noncancer Hazard Index of 1.

2 - EPA RSL's Residential Soil Table, April 2012. http://www.epa.gov/reg3hwmd/risk/human/rb-concentration_table/Generic_Tables/pdf/ressoil_sl_table_run_MAY2012.pdf. The RSL for direct contact with soils was used for the pathways of ingestion, dermal contact, and inhalation. Values are based on a Carcinogenic Target Risk (TR) of 1E-06 and a Noncancer Hazard Index of 1.

3 - NYSDEC Subpart 375-6: Remedial Program Soil Cleanup Objectives, Table 375-6.8(a): Unrestricted Use Soil Cleanup Objectives. <http://www.dec.ny.gov/regs/15507.html#15513>.

4 - NYSDEC Subpart 375-6: Remedial Program Soil Cleanup Objectives, Table 375-6.8(b): Restricted Use Soil Cleanup Objectives for the Protection of Groundwater. <http://www.dec.ny.gov/regs/15507.html#15513>.

5 - For data collected during years 2004 to 2006, petroleum hydrocarbons are the sum of Diesel Range Organics (TPH-DRO) and extractable hydrocarbons. For 1999 and 2010 data, petroleum hydrocarbons are the sum of TPH-DRO, and Gasoline Range Organics (TPH-GRO).

6 - Bis(2-ethylhexyl)phthalate is a known laboratory contaminant, therefore this chemical will not be considered as a contaminant of potential concern.

TABLE 2-1
ANALYTICAL DETECTIONS IN SITE SOILS
SITE 4 (AOC 22)
NWIRP BETHPAGE, NEW YORK
Page 7 of 8

Location:	EPA Risk-based SSL for the Protection of Groundwater ⁽¹⁾	EPA RSL for Residential Exposure Through Direct Contact ⁽²⁾	NYSDEC Unrestricted Use Soil Cleanup Objectives ⁽³⁾	NYSDEC Soil Cleanup Objectives (Protection of Groundwater) ⁽⁴⁾	SB108	SB108	SB109	SB110	SB111	SB112	SB113	SB114	SB201
Sample Date:					6/28/1999	12/11/2006	6/29/1999	7/19/1999	7/20/1999	7/22/1999	7/21/1999	7/22/1999	11/15/2010
Top Depth (feet):					55	55	55	55	53	58	57	57	73
Bottom Depth (feet):					57	57	57	57	55	60	59	59	74
ORGANICS (mg/kg)													
Petroleum Hydrocarbons ⁽⁵⁾	NE	NE	NE	NE				12		99		2.8 J	1.74 J
SEMIVOLATILES (µg/kg)													
2,4-Dimethylphenol	320	1,200,000	NE	NE	NS	NS	NS	NS	NS	NS	NS	NS	NS
2-Methylnaphthalene	140	230,000	NE	NE	NS	NS	NS	NS	NS	NS	NS	NS	NS
Acenaphthene	4,100	3,400,000	20,000	98,000	NS	NS	NS	NS	NS	NS	NS	NS	NS
Anthracene	42,000	17,000,000	100,000	1,000,000	NS	NS	NS	NS	NS	NS	NS	NS	NS
Benz(a)anthracene	10	150	1,000	1,000	NS	NS	NS	NS	NS	NS	NS	NS	NS
Benzo(a)pyrene	3.5	15	1,000	22,000	NS	NS	NS	NS	NS	NS	NS	NS	NS
Benzo(b)fluoranthene	35	150	1,000	1,700	NS	NS	NS	NS	NS	NS	NS	NS	NS
Benzo(g,h,i)perylene	NE	NE	100,000	1,000,000	NS	NS	NS	NS	NS	NS	NS	NS	NS
Benzo(k)fluoranthene	350	1,500	800	1,700	NS	NS	NS	NS	NS	NS	NS	NS	NS
Bis(2-ethylhexyl)phthalate ⁽⁶⁾	17	35,000	NE	NE	NS	NS	NS	NS	NS	NS	NS	NS	NS
Chrysene	1,100	15,000	1,000	1,000	NS	NS	NS	NS	NS	NS	NS	NS	NS
Fluoranthene	70,000	2,300,000	100,000	1,000,000	NS	NS	NS	NS	NS	NS	NS	NS	NS
Fluorene	4,000	2,300,000	30,000	386,000	NS	NS	NS	NS	NS	NS	NS	NS	NS
Indeno(1,2,3-cd)pyrene	120	150	500	8,200	NS	NS	NS	NS	NS	NS	NS	NS	NS
Naphthalene	0.47	3,600	12,000	12,000	NS	NS	NS	NS	NS	NS	NS	NS	NS
Phenanthrene	NE	NE	100,000	1,000,000	NS	NS	NS	NS	NS	NS	NS	NS	NS
Pyrene	9,500	1,700,000	100,000	1,000,000	NS	NS	NS	NS	NS	NS	NS	NS	NS

Notes:

mg/kg -- milligrams per kilogram blank value - not detected
µg/kg -- micrograms per kilogram NS - not sampled
J - estimated value NE - Not established

Bold cell - exceedance of Environmental Protection Agency (EPA) Regional Screening Level (RSL's or SSL's)

Shaded cell - exceedance of New York State Department of Environmental Conservation (NYSDEC) Soil Cleanup Objective

1 - EPA SSL's Soil to Groundwater Supporting Table, April 2012. http://www.epa.gov/reg3hwmd/risk/human/rb-concentration_table/Generic_Tables/pdf/ressoil_sl_table_run_MAY2012.pdf. The SSL was based on a Carcinogenic Target Risk (TR) of 1E-06 and a Noncancer Hazard Index of 1.

2 - EPA RSL's Residential Soil Table, April 2012. http://www.epa.gov/reg3hwmd/risk/human/rb-concentration_table/Generic_Tables/pdf/ressoil_sl_table_run_MAY2012.pdf. The RSL for direct contact with soils was used for the pathways of ingestion, dermal contact, and inhalation. Values are based on a Carcinogenic Target Risk (TR) of 1E-06 and a Noncancer Hazard Index of 1.

3 - NYSDEC Subpart 375-6: Remedial Program Soil Cleanup Objectives, Table 375-6.8(a): Unrestricted Use Soil Cleanup Objectives. <http://www.dec.ny.gov/regs/15507.html#15513>.

4 - NYSDEC Subpart 375-6: Remedial Program Soil Cleanup Objectives, Table 375-6.8(b): Restricted Use Soil Cleanup Objectives for the Protection of Groundwater. <http://www.dec.ny.gov/regs/15507.html#15513>.

5 - For data collected during years 2004 to 2006, petroleum hydrocarbons are the sum of Diesel Range Organics (TPH-DRO) and extractable hydrocarbons. For 1999 and 2010 data, petroleum hydrocarbons are the sum of TPH-DRO, and Gasoline Range Organics (TPH-GRO).

6 - Bis(2-ethylhexyl)phthalate is a known laboratory contaminant, therefore this chemical will not be considered as a contaminant of potential concern.

TABLE 2-1
ANALYTICAL DETECTIONS IN SITE SOILS
SITE 4 (AOC 22)
NWIRP BETHPAGE, NEW YORK
Page 8 of 8

Location: Sample Date: Top Depth (feet): Bottom Depth (feet):	EPA Risk-based SSL for the Protection of Groundwater ⁽¹⁾	EPA RSL for Residential Exposure Through Direct Contact ⁽²⁾	NYSDEC Unrestricted Use Soil Cleanup Objectives ⁽³⁾	NYSDEC Soil Cleanup Objectives (Protection of Groundwater) ⁽⁴⁾	SB203	SB204	SB204-DUP
					11/16/2010	11/17/2010	11/17/2010
					74	74	74
					75	75	75
ORGANICS (mg/kg)							
Petroleum Hydrocarbons ⁽⁵⁾	NE	NE	NE	NE	1.35 J	2.21 J	1.95 J
SEMIVOLATILES (µg/kg)							
2,4-Dimethylphenol	320	1,200,000	NE	NE			
2-Methylnaphthalene	140	230,000	NE	NE			
Acenaphthene	4,100	3,400,000	20,000	98,000			
Anthracene	42,000	17,000,000	100,000	1,000,000			
Benz(a)anthracene	10	150	1,000	1,000			
Benzo(a)pyrene	3.5	15	1,000	22,000			
Benzo(b)fluoranthene	35	150	1,000	1,700			
Benzo(g,h,i)perylene	NE	NE	100,000	1,000,000			
Benzo(k)fluoranthene	350	1,500	800	1,700			
Bis(2-ethylhexyl)phthalate ⁽⁶⁾	17	35,000	NE	NE			
Chrysene	1,100	15,000	1,000	1,000			
Fluoranthene	70,000	2,300,000	100,000	1,000,000			
Fluorene	4,000	2,300,000	30,000	386,000			
Indeno(1,2,3-cd)pyrene	120	150	500	8,200			
Naphthalene	0.47	3,600	12,000	12,000			
Phenanthrene	NE	NE	100,000	1,000,000			
Pyrene	9,500	1,700,000	100,000	1,000,000			

Notes:

mg/kg -- milligrams per kilogram blank value - not detected
µg/kg -- micrograms per kilogram NS - not sampled
J - estimated value NE - Not established

Bold cell - exceedance of Environmental Protection Agency (EPA) Regional Screening Level (RSL's or SSL's)

Shaded cell - exceedance of New York State Department of Environmental Conservation (NYSDEC) Soil Cleanup Objective

1 - EPA SSL's Soil to Groundwater Supporting Table, April 2012. http://www.epa.gov/reg3hwmd/risk/human/rb-concentration_table/Generic_Tables/pdf/ressoil_sl_table_run_MAY2012.pdf. The SSL was based on a Carcinogenic Target Risk (TR) of 1E-06 and a Noncancer Hazard Index of 1.

2 - EPA RSL's Residential Soil Table, April 2012. http://www.epa.gov/reg3hwmd/risk/human/rb-concentration_table/Generic_Tables/pdf/ressoil_sl_table_run_MAY2012.pdf. The RSL for direct contact with soils was used for the pathways of ingestion, dermal contact, and inhalation. Values are based on a Carcinogenic Target Risk (TR) of 1E-06 and a Noncancer Hazard Index of 1.

3 - NYSDEC Subpart 375-6: Remedial Program Soil Cleanup Objectives, Table 375-6.8(a): Unrestricted Use Soil Cleanup Objectives. <http://www.dec.ny.gov/regs/15507.html#15513>.

4 - NYSDEC Subpart 375-6: Remedial Program Soil Cleanup Objectives, Table 375-6.8(b): Restricted Use Soil Cleanup Objectives for the Protection of Groundwater. <http://www.dec.ny.gov/regs/15507.html#15513>.

5 - For data collected during years 2004 to 2006, petroleum hydrocarbons are the sum of Diesel Range Organics (TPH-DRO) and extractable hydrocarbons. For 1999 and 2010 data, petroleum hydrocarbons are the sum of TPH-DRO, and Gasoline Range Organics (TPH-GRO).

6 - Bis(2-ethylhexyl)phthalate is a known laboratory contaminant, therefore this chemical will not be considered as a contaminant of potential concern.

TABLE 2-2
ANALYTICAL DETECTIONS IN SITE GROUNDWATER
SITE 4 (AOC 22)
NWIRP BETHPAGE, NEW YORK
Page 5 of 6

Location: Sample ID: Sample Date:	NYSDOH MCLs ⁽¹⁾	EPA RSLs ⁽²⁾	MW11				
			MW11	MW11	MW11	MW11	MW11
			9/27/04	3/16/05	10/10/05	12/6/06	3/28/11
INORGANICS (µg/L)							
Aluminum	NE	16,000	31.3	72.4	28.35	55.8	
Arsenic ⁽³⁾	10	10					
Barium	2,000	2,000	39.1	47.1	60.35	66.8 J	27 J
Beryllium	4	4	0.32	1.5			
Cadmium ⁽³⁾	5	5	19	21.4	19.3	25.3 J	12.2
Calcium	NE	NE	11,000	12,200	12,650	13,300 J	12,200
Chromium	100	100	1.3	12.7	15.65	10.9 J	15.9 J
Cobalt ⁽³⁾	NE	4.7		0.74			
Copper	NE	1,300				2	5.77 J
Iron ⁽³⁾	300 ⁽⁴⁾	11,000	32.8	67.5	43.6	31.4	74.6
Lead	NE	15					
Magnesium	NE	NE	1,970	3,280	4,120	4,410 J	1,930
Manganese ⁽³⁾	300 ⁽⁴⁾	320	27.5	8.8	2.2	1.5	
Mercury	2	2			0.036		
Nickel	NE	NE		3	1.15	1.6	5.11 J
Potassium	NE	NE	1,260	1,870	3,855	3,070	1,040
Selenium	50	50					
Silver	100	71		0.59			
Sodium	NE	NE	4,880	15,400	22,500	31,600	11,300
Thallium ⁽³⁾	2	2					
Vanadium	NE	78					
Zinc	5,000	4,700	6.5	12.2	19.45	36.1 J	18.8 J
SEMIVOLATILES (µg/L)							
Bis(2-ethylhexyl)phthalate ⁽⁵⁾	6	6			3.1 J		
Caprolactam	50	7,700					
Carbazole	50	NE					
Diethylphthalate	50	11,000					
Naphthalene	50	0.14					
Pentachlorophenol	1	1					
Phenanthrene	50	NE					
Anthracene	50	1,300					
VOLATILES (µg/L)							
1,2-Dichloroethene (cis) ⁽⁶⁾	5	70					
1,2-Dichloroethene (total) ⁽⁶⁾	5	130					
Methyl Cyclohexane	50	NE					
Methyl Tert-butyl Ether	10	12					
Tetrachloroethene ⁽⁶⁾	5	5					
Benzene	5	5					
Ethylbenzene	5	700					
Trichloroethene ⁽⁶⁾	5	5	2.1 J	3.3 J	1.35 J	1.9	0.97 J
Vinyl Chloride ⁽⁶⁾	2	2					
Xylenes (total)	5	10,000					
FREE PRODUCT							
Thickness (feet)	NE	NE	NS	NS	NS	NS	NS

TABLE 2-2
ANALYTICAL DETECTIONS IN SITE GROUNDWATER
SITE 4 (AOC 22)
NWIRP BETHPAGE, NEW YORK
Page 6 of 6

Notes:

DUP - duplicate sample

µg/L -- micrograms per liter

NE - not established

blank value - not detected

shaded cell - exceedance of the New York State Department of Health (NYSDOH) Maximum Contaminant Level (MCL) http://www.health.ny.gov/regulations/nycrr/title_10/part_5/subpart_5-1_tables.htm.

bold cell - exceedance of the Environmental Protection Agency (EPA) Regional Screening Level (RSL) http://www.epa.gov/reg3hwmd/risk/human/rb-concentration_table/Generic_Tables/pdf/composite_sl_table_run_MAY2012.pdf.

NS - not sampled

J - estimated value

1 - NYSDOH Part 5, Subpart 5-1: Public Water Systems; Table 1: Inorganic Chemicals and Physical Characteristics Maximum Contaminant Level Determination; Table 3: Organic Chemicals Maximum Contaminant Level (MCL) Determination; Table 9D: Organic Chemicals - Principal Organic Contaminants Minimum Monitoring Requirements. http://www.health.ny.gov/regulations/nycrr/title_10/part_5/subpart_5-1_tables.htm.

2 - EPA RSL Summary Table April 2012. http://www.epa.gov/reg3hwmd/risk/human/rb-concentration_table/Generic_Tables/pdf/composite_sl_table_run_MAY2012.pdf. The EPA RSL is the MCL for the given chemical (if available), or a default tapwater RSL for that chemical.

3 - Arsenic, cadmium, cobalt, iron, manganese, and thallium exceeded either the NYSDOH MCLs and/or the EPA RSLs over the course of sampling. There are no current exceedances documented for either arsenic or thallium; cadmium and iron levels have greatly decreased; levels of manganese were stable throughout sampling; and cobalt was currently detected at levels exceeding EPA RSLs in MW06 only. Overall, there was no significant change in metals in groundwater due to operation of the Closed Loop Bioreactor (CLB) system.

4 - If iron and manganese are present, the total concentration of both should not exceed 500 µg/L.

5 - Bis(2-ethylhexyl)phthalate is a known laboratory contaminant, therefore this chemical will not be considered as a contaminant of potential concern (COPC).

6 - Exceedances of volatiles in groundwater are addressed through the Record of Decision for site Groundwater for Operable Unit 2, and therefore are not addressed in this Remedial Alternatives Analysis (RAA).

7 - Groundwater monitoring wells MW01 and MW02 were the only wells where measurable thickness of free product was detected. Because of the very small volumes of free product accumulating in the monitoring wells, it was necessary to collect composite samples to meet laboratory-specified volume requirements.

TABLE 2-3
MAXIMUM DETECTION SUMMARY OF SITE GROUNDWATER SAMPLES
SITE 4 (AOC 22)
NWIRP BETHPAGE, NEW YORK

Chemical	NYSDOH MCLs ⁽¹⁾	EPA RSLs ⁽²⁾	Maximum Concentration of Detection	Location and Well Screen Depth (feet) of Maximum Detection	Contaminant of Potential Concern? (Yes[Y] / No [N])
INORGANICS (µg/L)					
Aluminum	NE	16,000	518	MW07	N
Arsenic ⁽³⁾	10	10	ND	--	N
Barium	2,000	2,000	77.1	MW06	N
Beryllium	4	4	0.716 J	MW06	N
Cadmium ⁽³⁾	5	5	12.2	MW11	Y
Calcium	NE	NE	38,900	MW06	N
Chromium	100	100	25.4 J	MW10	N
Cobalt ⁽³⁾	NE	4.7	49.5	MW06	Y
Copper	NE	1,300	9.54 J	MW06	N
Iron ⁽³⁾	300 ⁽⁴⁾	11,000	8,880	MW06	Y
Lead	NE	15	ND	--	N
Magnesium	NE	NE	4,850	MW06	N
Manganese ⁽³⁾	300 ⁽⁴⁾	320	2,570	MW06	Y
Mercury	2	2	0.61	MW06	N
Nickel	NE	NE	14.8 J	MW06	N
Potassium	NE	NE	3,370	MW06	N
Selenium	50	50	ND	--	N
Silver	100	71	ND	--	N
Sodium	NE	NE	25,700	MW10	N
Thallium ⁽³⁾	2	2	ND	--	N
Vanadium	NE	78	ND	--	N
Zinc	5,000	4,700	53.5	MW07	N
SEMIVOLATILES (µg/L)					
Bis(2-ethylhexyl)phthalate ⁽⁵⁾	6	6	7.7 J	MW02	N
Caprolactam	50	7,700	ND	--	N
Carbazole	50	NE	4.2 J	MW01	N
Diethylphthalate	50	11,000	ND	--	N
Naphthalene	50	0.14	20	MW01, MW02	Y
Pentachlorophenol	1	1	8.5 J	MW06	Y
Phenanthrene	50	NE	3.6 J	MW01	N
Anthracene	50	1,300	1.7 J	MW06	N
VOLATILES (µg/L)					
1,2-Dichloroethene (cis) ⁽⁶⁾	5	70	48	MW02	N
1,2-Dichloroethene (total) ⁽⁶⁾	5	130	47	MW02	N
Methyl Cyclohexane	50	NE	ND	--	N
Methyl Tert-butyl Ether	10	12	ND	--	N
Tetrachloroethene ⁽⁶⁾	5	5	1.2	MW10	N
Benzene	5	5	17	MW01	Y
Ethylbenzene	5	700	18	MW01	Y
Trichloroethene ⁽⁶⁾	5	5	67	MW02	N
Vinyl Chloride ⁽⁶⁾	2	2	27	MW02	N
Xylenes (total)	5	10,000	7.6	MW01	Y

TABLE 2-3
MAXIMUM DETECTION SUMMARY OF SITE GROUNDWATER SAMPLES
SITE 4 (AOC 22)
NWIRP BETHPAGE, NEW YORK
Page 2 of 2

Notes:

µg/L -- micrograms per liter

NE - not established

ND - not detected

shaded cell - exceedance of the New York State Department of Health (NYSDOH) Maximum Contaminant Level (MCL)
http://www.health.ny.gov/regulations/nycrr/title_10/part_5/subpart_5-1_tables.htm.

bold cell - exceedance of the Environmental Protection Agency (EPA) Regional Screening Level (RSL)
http://www.epa.gov/reg3hwmd/risk/human/rb-concentration_table/Generic_Tables/pdf/composite_sl_table_run_MAY2012.pdf.

J - estimated value

1 - NYSDOH Part 5, Subpart 5-1: Public Water Systems; Table 1: Inorganic Chemicals and Physical Characteristics Maximum Contaminant Level Determination; Table 3: Organic Chemicals Maximum Contaminant Level (MCL) Determination; Table 9D: Organic Chemicals - Principal Organic Contaminants Minimum Monitoring Requirements.

2 - EPA RSL Summary Table April 2012. http://www.epa.gov/reg3hwmd/risk/human/rb-concentration_table/Generic_Tables/pdf/composite_sl_table_run_MAY2012.pdf. The EPA RSL is the MCL for the given

3 - Arsenic, cadmium, cobalt, iron, manganese, and thallium exceeded either the NYSDOH MCLs and/or the EPA RSLs over the course of sampling. There are no current exceedances documented for either arsenic or thallium; cadmium and iron levels have greatly decreased; levels of manganese were stable throughout sampling; and cobalt was currently detected at

4 - If iron and manganese are present, the total concentration of both should not exceed 500 µg/L.

5 - Bis(2-ethylhexyl)phthalate is a known laboratory contaminant, therefore this chemical will not be considered as a contaminant of potential concern (COPC).

6 - Exceedances of chlorinated volatiles in groundwater are addressed through the Record of Decision for site Groundwater for Operable Unit 2, and therefore are not addressed in this Remedial Alternatives Analysis (RAA).

**TABLE 2-4
MAXIMUM DETECTION SUMMARY OF SITE SOILS SAMPLES
SITE 4 (AOC 22)
NWIRP BETHPAGE, NEW YORK**

Chemical	EPA Risk-based SSL for the Protection of Groundwater ⁽¹⁾	EPA RSL for Residential Exposure Through Direct Contact ⁽²⁾	NYSDEC Unrestricted Use Soil Cleanup Objectives ⁽³⁾	NYSDEC Soil Cleanup Objectives (Protection of Groundwater) ⁽⁴⁾	Current Maximum Concentration of Detection	Location and Well Screen Depth (feet) of Maximum Detection	Contaminant of Potential Concern? (Yes[Y] / No[N])
SEMIVOLATILES (µg/kg)							
2,4-Dimethylphenol	320	1,200,000	NE	NE	300 J	SB103-4042	N
2-Methylnaphthalene	140	230,000	NE	NE	73,000	SB103-5961	Y
Acenaphthene	4,100	3,400,000	20,000	98,000	6,400 J	SB103-5961	Y
Anthracene	42,000	17,000,000	100,000	1,000,000	8,400 J	SB103-5961	N
Benz(a)anthracene	10	150	1,000	1,000	4,200 J	SB103-5961	Y
Benzo(a)pyrene	3.5	15	1,000	22,000	2,700 J	SB103-5961	Y
Benzo(b)fluoranthene	35	150	1,000	1,700	3,300 J	SB101-5961	Y
Benzo(g,h,i)perylene	NE	NE	100,000	1,000,000	1,400 J	SB101-5961	N
Benzo(k)fluoranthene	350	1,500	800	1,700	150 J	SB104-4951	N
Bis(2-ethylhexyl)phthalate ⁽⁵⁾	17	35,000	NE	NE	320 J	SB104-4951	N
Chrysene	1,100	15,000	1,000	1,000	8,600 J	SB103-5961	Y
Fluoranthene	70,000	2,300,000	100,000	1,000,000	3,400 J	SB103-5961	N
Fluorene	4,000	2,300,000	30,000	386,000	25,000 J	SB103-5961	Y
Indeno(1,2,3-cd)pyrene	120	150	500	8,200	200 J	SB104-4951	Y
Naphthalene	0.47	3,600	12,000	12,000	15,000 J	SB103-5961	Y
Phenanthrene	NE	NE	100,000	1,000,000	39,000 J	SB103-5961	N
Pyrene	9,500	1,700,000	100,000	1,000,000	36,000	SB103-5961	Y

Notes:

µg/kg -- micrograms per kilogram

J - estimated value

NE - Not established

Shaded cell - exceedance

1 - EPA SSL's Soil to Groundwater Supporting Table, April 2012. http://www.epa.gov/reg3hwmd/risk/human/rb-concentration_table/Generic_Tables/pdf/ressoil_sl_table_run_MAY2012.pdf. The SSL was based on a Carcinogenic Target Risk (TR) of 1E-06 and a Noncancer Hazard Index of 1.

2 - EPA RSL's Residential Soil Table, April 2012. http://www.epa.gov/reg3hwmd/risk/human/rb-concentration_table/Generic_Tables/pdf/ressoil_sl_table_run_MAY2012.pdf. The RSL for direct contact with soils was used for the pathways of ingestion, dermal contact, and inhalation. Values are based on a Carcinogenic Target Risk (TR) of 1E-06 and a Noncancer Hazard Index of 1.

3 - NYSDEC Subpart 375-6: Remedial Program Soil Cleanup Objectives, Table 375-6.8(a): Unrestricted Use Soil Cleanup Objectives. <http://www.dec.ny.gov/regs/15507.html#15513>.

4 - NYSDEC Subpart 375-6: Remedial Program Soil Cleanup Objectives, Table 375-6.8(b): Restricted Use Soil Cleanup Objectives for the Protection of Groundwater. <http://www.dec.ny.gov/regs/15507.html#15513>.

5 - Bis(2-ethylhexyl)phthalate is a known laboratory contaminant, therefore this chemical will not be considered as a contaminant of potential concern.

**TABLE 2-5
CHEMICALS OF POTENTIAL CONCERN (COPC) FOR SITE GROUNDWATER AND SOILS
SITE 4 (AOC 22)
NWIRP BETHPAGE, NEW YORK**

Chemical	Chemical Abstract Service (CAS) Number	Soil COPC	Groundwater COPC
METALS			
Cadmium	7440-43-9	No	Yes
Cobalt	7440-48-4	No	Yes
Iron	7439-89-6	No	Yes
Manganese	7439-96-5	No	Yes
SEMI-VOLATILE ORGANICS			
2-Methylnaphthalene	91-57-6	Yes	No
Acenaphthene	208-96-8	Yes	No
Benz(a)anthracene	56-55-3	Yes	No
Benzo(a)pyrene	50-32-8	Yes	No
Benzo(b)fluoranthene	205-99-2	Yes	No
Chrysene	218-01-9	Yes	No
Fluorene	86-73-7	Yes	No
Indeno(1,2,3-cd)pyrene	193-39-5	Yes	No
Naphthalene	91-20-3	Yes	Yes
Pentachlorophenol	87-86-5	No	Yes
Pyrene	129-00-0	Yes	No
VOLATILES ORGANICS			
Benzene	71-43-2	No	Yes
Ethylbenzene	100-41-4	No	Yes
Xylenes (total)	1330-20-7	No	Yes

Notes:

Chlorinated volatile organic compound (VOC) contamination is in groundwater from other source areas and is currently being addressed through implementation of various components associated with the Record of Decision for Groundwater for Operable Unit 2 (OU-2). Naphthalene (20 µg/L) and pentachlorophenol (8.5 µg/L) were the only semi-volatile organic compounds (SVOCs) currently exceeding maximum contaminant limits in groundwater. Metals contamination in groundwater has decreased since 2004 and may be attributable to the Closed-Loop Bioreactor (CLB) system that operated from 2004 to 2006. Metals and petroleum related VOCs will be monitored as part of a sampling plan, but will not be specifically addressed as a separate remedy.

The semi-volatile organics consist of 10 polynuclear aromatic hydrocarbons (PAHs) and pentachlorophenol.

**TABLE 3-1
CHEMICAL-SPECIFIC APPLICABLE OR RELEVANT AND APPROPRIATE REQUIREMENTS (ARARs)
SITE 4 (AOC 22) FS/CMS
NWIRP BETHPAGE, NEW YORK**

MEDIA	REQUIREMENT	Description	PREREQUISITE	CITATION	ARAR DETERMINATION	COMMENT
FEDERAL CHEMICAL SPECIFIC ARARs						
Soil, groundwater	EPA Regional Screening Levels (for human health)	Generic risk-based screening values and toxicity values for human health established for EPA Region III and now generalized for all Regions. Typically used for human health risk assessment screening, risk calculations, and Preliminary Remediation Goal (PRG) development.	Contaminated environmental media can be screened against these generic values for a preliminary indicator of risk. Also, one can prepare site-specific values if needed using the reference materials.	EPA <i>Regional Screening Levels (RSLs)</i> (April 2012) http://www.epa.gov/reg3hwmd/risk/human/rb-concentration_table/Generic_Tables/pdf/composite_sl_table_run_MAY2012.pdf	To be considered	Values were used to determine baseline risk in the Remedial Alternatives Analysis in PRG development. New York State Department of Environmental Conservation (NYSDEC) Maximum Contaminant Levels (MCLs) fall within USEPA risk criteria (10^{-4} to 10^{-6}) incremental lifetime cancer risk or a hazard index less than 1.
NEW YORK STATE CHEMICAL-SPECIFIC ARARs						
Groundwater	New York Water Classifications and Quality Standards	Regulations for the control and prevention of water pollutants. NWIRP Site 4 is in Nassau County with groundwater classified as GA.	Standards are used to protect the public health or welfare and enhance water quality.	6 NYCRR Parts 701.15 and 702.3	Relevant and Appropriate	Standards applicable for actions involving the selection of groundwater remediation goals based on Site groundwater being classified as GA.
Groundwater	New York Public Water Supply Regulations	Drinking water quality standards for New York.	Potential site contamination impact on public water supply to be addressed by, or potentially caused by, environmental action.	10 NYCRR Part 5, Subpart 5-1	Applicable	The aquifer, which is a drinking water source, is impacted by site contamination. NYSDOH MCLs are considered in the development of PRGs.
Soil	New York State Department of Environmental Conservation (NYSDEC) Soil Cleanup Objectives	Provides a basis and procedure to determine soil cleanup levels.	Contaminated soils can be screened for risk.	Chapter IV, Part 375, Subpart 375-6, Table 375-6.8(a)	Applicable	Soil cleanup standards impact selection of soil remediation goals.
Soil	NYSDEC Soil Cleanup Objectives for the Protection of Groundwater	Provides a basis and procedure to determine soil cleanup levels to prevent the exposure pathway of soil contamination transfer to groundwater in a human health risk scenario.	Contaminated soils can be screened for the risk of contamination migrating from soils to groundwater.	Chapter IV, Part 375, Subpart 375-6, Table 375-6.8(b)	Applicable	Soil cleanup standards impact selection of soil remediation goals.

**TABLE 3-2
LOCATION-SPECIFIC APPLICABLE OR RELEVANT AND APPROPRIATE REQUIREMENTS (ARARs)
SITE 4 (AOC 22) FS/CMS
NWIRP BETHPAGE, NEW YORK**

MEDIA	REQUIREMENT	Description	PREREQUISITE	CITATION	ARAR DETERMINATION	COMMENT
FEDERAL LOCATION SPECIFIC ARARs						
Groundwater	SDWA Sole Source Aquifer	SDWA prevents federal funding from being committed to any project that may contaminate a "sole source aquifer," meaning any EPA-designated aquifer that is the only principal drinking water supply for a given area which, if contaminated, would present a significant human health hazard.	Comprehensive Environmental Response, Compensation, and Liability Act (CERCLA) activities normally do not increase pre-existing contamination of sole source aquifers.	40 CFR 149.3	Applicable	The aquifer beneath Nassau County is a sole source aquifer (43 CFR 26611). Alternatives that extract and treat site groundwater would comply with these requirements.
NEW YORK STATE LOCATION SPECIFIC ARARs						
Groundwater	New York State Department of Environmental Conservation (NYSDEC) Water Classifications and Standards of Quality and Purity	Provides a classification of groundwater and surface waters in the area.	Standards are used to protect the public health or welfare and enhance water quality.	6 NYCRR 701	Relevant and Appropriate	Groundwater in this area is classified as Class GA. 6 NYCRR 701.15, "The best usage of Class GA waters is as a source of potable water supply."

**TABLE 3-3
ACTION-SPECIFIC APPLICABLE OR RELEVANT AND APPROPRIATE REQUIREMENTS (ARARs)
SITE 4 (AOC 22) FS/CMS
NWIRP BETHPAGE, NEW YORK**

MEDIA	REQUIREMENT	Description	PREREQUISITE	CITATION	ARAR DETERMINATION	COMMENT
Groundwater	SDWA Underground Injection Control (UIC) Program	Regulations establish minimum requirements for UIC programs.	Actions are taken when contaminants that could be introduced by way of a UIC program could endanger drinking water sources.	40 CFR 144.81 and 0.82	Applicable	Applicable for alternatives that would involve injection of wastewater and solvent into the subsurface via Class V wells.
Fuel and Oil	Materials Management	When cumulative onsite bulk storage volume of fuel and/or oil is greater than 1,320 gallons, comprised of containers greater than 55 gallons, the greater than 55-gallon-containers (e.g., drums or tanks) must be secondarily contained, inspected routinely, have a Spill Prevention Control and Countermeasures (SPCC) plan prepared, and meet other specific SPCC	Fuels and oils stored on site in containers greater than 55 gallons when cumulative onsite bulk storage volume is greater than 1,320 gallons.	40 CFR 112.3 and -.6	Applicable	Applicable for alternatives 3 to 5, which include temporary onsite staging for waste oils and solvents such as Vertec. Any oils would be stored in appropriate containers and controlled areas as appropriate.
Fuels and Oil	Materials Management	State regulation of bulk oil storage tanks (greater than 1,100 gallons), including design requirements, reporting, and inspections. Program is administered by Nassau County.	Applies to new petroleum tank construction with more than 1,100 gallons of compacity.	6 NYCRR Parts 615.8 to .14	Applicable	Applicable for alternatives 3 to 5, which include temporary onsite staging for waste oils and solvents such as Vertec. Any oils would be stored in appropriate containers and controlled areas as appropriate.
Hazardous Waste	New York Identification and Listing of Hazardous Wastes Regulations	Characterization and identification of wastes.	Generation of hazardous wastes.	6 NYCRR 371.3, 372.2, and 373-1.1	Applicable	Prior to offsite disposal, waste materials will be characterized for hazardous waste classification.
Air	New York Air Pollution Control Regulations	Regulations for the control and prevention of air pollutants.	Would be applicable to alternatives that generate off-gas.	6 NYCRR Parts 212.9	Applicable	Alternatives with off-gas treatment may need to be screened against these standards for compliance purposes.

**TABLE 3-4
PRELIMINARY REMEDIATION GOALS FOR SITE SOILS
SITE 4 (AOC 22)
NWIRP BETHPAGE, NEW YORK**

Chemical	Chemical Abstract Service (CAS) Number	Maximum Detected Concentration (µg/Kg)	EPA RSL Range ⁽¹⁾ (µg/Kg)	NYSDEC Unrestricted Use Soil Cleanup Objectives ⁽²⁾ (µg/Kg)	NYSDEC Soil Cleanup Objectives (Protective of Groundwater) ⁽³⁾ (µg/Kg)	Contract Required Quantitation Limit (CRQL) ⁽⁴⁾ (µg/Kg)	Selected Soil PRG ⁽⁵⁾ (µg/Kg)
SEMIVOLATILES							
2-Methylnaphthalene	91-57-6	73,000	140 (GW)	NE	NE	170	140
Acenaphthene	208-96-8	6,400J	4,100 (GW)	20,000	98,000	170	4,100
Benz(a)anthracene	56-55-3	4,200J	10 - 1,000 (GW)	1,000	1,000	170	1,000
Benzo(a)pyrene	50-32-8	2,700J	3.5 - 350 (GW)	1,000	22,000	170	350
Benzo(b)fluoranthene	205-99-2	3,300J	35 - 3,500 (GW)	1,000	1,700	170	1,000
Chrysene	218-01-9	8,600J	1,100 - 110,000 (GW)	1,000	1,000	170	1,000
Fluorene	86-73-7	25,000J	4,000 - 400,000 (GW)	30,000	386,000	170	30,000
Indeno(1,2,3-cd)pyrene	193-39-5	200J	120 - 12,000 (GW)	500	8,200	170	500
Naphthalene	91-20-3	15,000J	0.47 to 47 (GW)	12,000	12,000	170	47
Pyrene	129-00-0	36,000J	9,500 (GW)	100,000	1,000,000	170	9,500

Notes:

µg/Kg - micrograms per kilogram

NE - not established

1 - EPA SSL value are based on a DAF = 1 and a Hazard Quotient of 1. Values are given in the range of 10E-6 to 10E-4. EPA SSL's Soil to Groundwater Supporting Table, April 2012. http://www.epa.gov/reg3hwmd/risk/human/rb-concentration_table/Generic_Tables/pdf/ressoil_sl_table_run_MAY2012.pdf. Value presented is based on the lower of the direct contact risk (DC) or for protection of groundwater (GW). A range indicates that the chemical is listed as a carcinogen, otherwise a noncarcinogenic value of 1.0 is provided.

2 - NYSDEC Subpart 375-6: Remedial Program Soil Cleanup Objectives, Table 375-6.8(a): Unrestricted Use Soil Cleanup Objectives.

<http://www.dec.ny.gov/regs/15507.html#15513>.

3 - NYSDEC Subpart 375-6: Remedial Program Soil Cleanup Objectives, Table 375-6.8(b): Restricted Use Soil Cleanup Objectives for the Protection of Groundwater.

<http://www.dec.ny.gov/regs/15507.html#15513>.

4 - CRQL is the minimum concentration value a chemical can be tested for detection during sampling. This value is used to provide a base for comparison with criteria.

5 - Preliminary Remediation Goal (PRG) is selected based on the most conservative criteria that can be sampled for detection for a given chemical.

**TABLE 3-5
PRELIMINARY REMEDIATION GOALS FOR SITE GROUNDWATER
SITE 4 (AOC 22)
NWIRP BETHPAGE, NEW YORK**

Chemical	Chemical Abstract Service (CAS) Number	Maximum Detected Concentration (µg/L)	NYSDOH MCLs (µg/L) ⁽¹⁾	EPA RSLs (µg/L) ⁽²⁾	Contract Required Quantitation Limit (CRQL) (µg/L) ⁽³⁾	Selected Groundwater PRG (µg/L) ⁽⁴⁾
METALS ⁽⁵⁾						
Cadmium	7440-43-9	12.2	5	6.9	--	5
Cobalt	7440-48-4	49.5	NE	4.7	--	4.7
Iron	7439-89-6	8,880	300	11,000	--	11,000
Manganese	7439-96-5	2,570	300	320	--	3,200
SEMIVOLATILES						
Naphthalene	91-20-3	20	50	0.14 to 14	5	14
Pentachlorophenol	87-86-5	9	1	0.17 to 17	10	1
VOLATILES ⁽⁵⁾						
Benzene	71-43-2	17	5	0.39 to 39	5	5
Ethylbenzene	100-41-4	18	5	1.3 to 130	5	5
Xylenes (total)	1330-20-7	7.6	5	190	5	5

Notes:

µg/L - microgram per liter

NE - not established

1 - NYSDOH Part 5, Subpart 5-1: Public Water Systems; Table 1: Inorganic Chemicals and Physical Characteristics Maximum Contaminant Level Determination; Table 3: Organic Chemicals Maximum Contaminant Level (MCL) Determination; Table 9D: Organic Chemicals - Principal Organic Contaminants Minimum Monitoring Requirements. http://www.health.ny.gov/regulations/nycrr/title_10/part_5/subpart_5-1_tables.htm.

2 - EPA RSL Summary Table April 2012. http://www.epa.gov/reg3hwmd/risk/human/rb-concentration_table/Generic_Tables/pdf/composite_sl_table_run_MAY2012.pdf.

The EPA RSL is the MCL for the given chemical (if available), or a default tapwater RSL for that chemical.

3 - CRQL is the minimum concentration value a chemical can be tested for detection during sampling. This value is used to provide a base for comparison with criteria.

4 - Preliminary Remediation Goal (PRG) is selected based on the most conservative criteria that can be sampled for detection for a given chemical.

5 - Chlorinated volatile organic compound (VOC) contamination is in groundwater from other Navy source areas and is currently being addressed through implementation of various components associated with the Record of Decision for Groundwater for Operable Unit 2 (OU-2). Metals contamination in groundwater has significantly decreased since 2004 (one to two orders of magnitude) and is attributable to the Closed-Loop Bioreactor (CLB) system that operated from 2004 to 2006. Metals and petroleum related VOCs (e.g. benzene, ethyl benzene, xylenes (total)) will be monitored as part of a sampling plan, but will not be specifically addressed as a separate remedy.

**TABLE 4-1
GENERAL RESPONSE ACTIONS FOR SOIL
SITE 4 FORMER UST AREA
NWIRP BETHPAGE, NEW YORK**

General Response Action (GRA)	Effect Associated with Remedial Action Objectives (RAOs)
No Action	None. Serves as a baseline to compare other response actions.
Institutional Controls	Reduces human exposure to contaminated groundwater or soils by placing restrictions on aquifer use and activities that may result in exposure to contaminated soil. Monitoring may be performed in conjunction with other alternatives to determine if RAOs are being met or if/when cleanup goals are met.
Containment	Minimizes or prevents the migration of contaminants in the soils to surrounding groundwater and receptors.
Removal	Removes contaminants from the saturated zone by physical extraction of impacted soil.
Disposal/Reuse	Long-term containment of contaminated media in an engineering disposal facility or beneficial re-use of media.
Ex-Situ Treatment	Involves taking contaminated media out of its natural place, applying treatment, and either placing treated media back into the site, or managing off-site.
In-Situ Treatment	Treats contaminants in place via chemical, biological, and/or physical processes.

**TABLE 4-2
SCREENING OF TECHNOLOGIES AND PROCESS OPTIONS FOR SOIL
SITE 4 FORMER UST AREA
NWIRP BETHPAGE, NEW YORK
Page 1 of 4**

General Response Action	Remedial Technology	Process Options	Description	Chemical Class		Screening			
				PAHs	Free Product	Effectiveness	Implementability	Relative Cost	Screening comments
No Action	No Action	Not Applicable	No activities conducted at site to address contamination.			Not effective, does not achieve PRGs and there is no evaluation of potential impacts to human health and the environment.	Readily implementable, no actions required.	Low.	Retained. Provides basis of comparison to other process options and remediation technologies.
Institutional Controls	Administrative restrictions	Land-Use Controls (LUCs)/ Deed Restrictions and Notices	Administrative action used to restrict groundwater use and future site activities.	√	√	Deed notifications are viable, in combination with other technologies, since contaminated material may remain in place. Deed notifications could consist of land use and groundwater use restrictions.	Easy to implement on the facility. Would be more difficult to extend off-site or enforce after property transfer. Normally combined with other technologies to enhance performance. Can be used for short-term or long-term remedies.	Low.	Retained. Deed restrictions will be in place while contamination remains.
	Access Restrictions	Fences	Security fences installed around potentially contaminated areas to limit access.	√	√	Prevents public from entering site, and provides site security. Effective restrictions and controls associated with the property/land.	Site contamination is located within existing facility boundaries.	Low.	Not selected. Provide no additional protection.
	Monitoring/Sampling	Performance and Compliance Monitoring	Sampling and analysis to evaluate the migration of contaminants within or the potential contamination of groundwater.	√	√	Provides performance and compliance monitoring data.	Easily implemented. Prepare a monitoring plan and sample on established schedule. Minimal infrastructure and O&M required.	Low annual costs, but long-term costs can be moderate because of extended period of operation.	Retained. Will be implemented with action alternatives.
	Monitored Natural Attenuation (MNA)	Intrinsic Process and Performance Monitoring	Natural attenuation (all mechanisms including biodegradation, dilution, etc.) coupled with regular monitoring as well as for other indicators of biodegradation.	√	√	Effective for sites where there are no unacceptable current risks (no exposure) and future risks are minimal. Current site contamination consists of moderate to high concentrations of fuels and contaminants.	Easily implemented, only sampling would be required to monitor progress of attenuation. Minimal infrastructure and O&M required.	Low annual costs, but long-term costs can be moderate because of extended period of operation.	Retained. May be implemented as a component of other alternatives.
Containment	Cover	Soil Cover	Use of permeable material (e.g., soil) to prevent exposure to contamination.	√	√	Would be effective in preventing potential receptors from direct contact with contaminated soil, but would not address contaminant migration from soil to groundwater.	Easily implemented, and materials and services required to implement this technology are readily available. Would impact future site use.	Low.	Not selected. Does not address possible spread of contamination from soils to groundwater.
	Capping	Capping	Use of impermeable or semi-permeable materials (e.g., soil, clay, synthetic membrane, asphalt) to prevent exposure to contamination and/or reduce the vertical migration of contaminants to groundwater.	√	√	Cover would be effective in preventing potential receptors from direct contact with contaminated soil. Due to the relative depth of contaminated soils (approximately 20 feet bgs), direct contact with contamination is unlikely. Would not address contaminant migration from soil to groundwater.	Installation would be easy, and materials and services required to implement this technology are readily available. Existing structures at the site would need to be considered prior to the construction of the cover.	Low.	Not selected. Does not address possible spread of contamination from soils to groundwater.
Removal - Solids	Bulk Excavation	Bulk Excavation	Mechanical removal of solid materials using construction equipment.	√	√	Excavation is a well-proven and effective method. Excavation would remove most of the highly contaminated soils, and remaining soils would not pose an unacceptable risk to human health or the environment. Would be combined with sampling to verify effectiveness of removal action.	Would be difficult to implement due to the depth of contamination and presence of existing structures and utilities in the vicinity of the excavation.	Costs increase with the depth of contamination. Piling requirements and utility relocation would add significant cost components.	Retained. This remedial alternative was evaluated as an unrestricted use/unrestricted exposure (UU/UE) scenario.

**TABLE 4-2
SCREENING OF TECHNOLOGIES AND PROCESS OPTIONS FOR SOIL
SITE 4 FORMER UST AREA
NWIRP BETHPAGE, NEW YORK
Page 2 of 4**

General Response Action	Remedial Technology	Process Options	Description	Chemical Class		Screening			
				PAHs	Free Product	Effectiveness	Implementability	Relative Cost	Screening comments
Removal - Free Product Recovery	Free Product Recovery	Bioslurping	LNAPL removal is accomplished by combining thermal technologies (steam injection to increase viscosity of free product) and vacuum-enhanced free product recovery to extract LNAPL from the capillary fringe and water table.	√	√	Bioslurping is proven effective in remediating soils contaminated by petroleum hydrocarbons. Bioslurping is applicable to sites with deep water tables (greater than 30 feet).	This technology can be used in conjunction with in-situ thermal treatments to recover free product.	Low to moderate.	Retained. In-situ bioslurping will be combined with thermal technologies needed for free product removal.
	Free Product Recovery	Skimming Systems	Free product is recovered from a well or trench without the removal of groundwater.	√	√	Small volumes of free product are removed because of the limited area of influence in the individual well. More often used in emergency or short-term remedial actions.	Due to a lack of thickness in the free product layer, this removal mechanism is not expected to be easily implemented.	Low.	Not selected. Not easily implemented with a limited thickness of the free product layer.
Disposal / Reuse	Landfill	Hazardous or Nonhazardous Landfill	Disposal of excavated material in an off-site landfill.	√	√	Contaminated material is not expected to be hazardous. Removal and off-site disposal is widely applicable to site contaminants due to the limited spread of groundwater contamination.	Excavated soil is expected to be RCRA non-hazardous and may be disposed in a RCRA subtitle D waste facility.	Cost is expected to be low to moderate. Costs can increase with respect to distance to the nearest storage facility and required permits.	Retained. Excavation was retained as a process option.
	Recycling and Salvage	Recycling and Salvage	Recycling of fill materials components instead of disposal.			Involves re-use of site components.	Can be considered as a secondary technology. No recyclable material is expected from this site.	Low.	Not selected. No recyclable material is expected from this site.
	Consolidation	Consolidation	Relocation of untreated soil on site.	√	√	Would be effective as uncontaminated soils can be used as backfill, and other soils could be segregated onsite.	Implementable as combined with excavation and other technologies if waste soils are present. Consolidation areas on site are limited to the existing Site.	Low.	Retained. Excavation was retained as a process option.
	Beneficial Reuse	Beneficial Reuse as Fill Material	On-site reuse of uncontaminated or treated soil.	√	√	Would be effective as uncontaminated soils can be used as backfill.	Implementable as combined with excavation and other technologies if waste soils are present.	Low.	Retained. Excavation was retained as a process option.
	Beneficial Reuse	Reuse of Waste Oil	Waste oils recovered (i.e. TPH as free product) can be reused for asphalt plants or as fuel.	√	√	Free product can be reused for applications such as asphalt plants or as fuel instead of disposal of the free product.	Implementable as combined with alternatives that actively remove free product.	No cost, may reduce disposal costs.	Retained. Will be considered for alternatives that remove free product.
Ex-Situ Treatment	Fixation	Solidification	Immobilization of contaminants by mixing with cement, fly ash, kiln dust, etc.			Effective for trapping inorganic contaminants. Not as effective for organic chemicals or free product.	This process can result in significant increases in overall volume. Treatment facilities are limited.	Moderate.	Not selected. Limited effectiveness for target contaminant group.
	Physical	Dewatering	Removal of free water from wastes using gravity (dewatering pad) or equipment such as a filter press.	√	√	Common technology in association with excavation processes; well-proven and effective. Soil is sandy, and would free water would easily drain.	Implementable as combined with excavation and other technologies if waste soils are to be excavated below the water table.	Low.	Retained. Will be implemented for saturated soils if excavation extends below the water table.
	Physical	Soil Washing/Solvent Extraction	Separation of contaminants from a medium by contact with water or solvents with a high affinity for the contaminants of concern.	√	√	Target contaminant groups for soil washing include both metals and fuels. Can allow for recovery of metals and some inorganics and organics.	Solvent extraction vendors are limited.	Moderate.	Not selected. Other more common, cost effective, and viable treatment technologies are available.

**TABLE 4-2
SCREENING OF TECHNOLOGIES AND PROCESS OPTIONS FOR SOIL
SITE 4 FORMER UST AREA
NWIRP BETHPAGE, NEW YORK
Page 3 of 4**

General Response Action	Remedial Technology	Process Options	Description	Chemical Class		Screening			
				PAHs	Free Product	Effectiveness	Implementability	Relative Cost	Screening comments
Ex-Situ Treatment (cont.)	Thermal	Incineration	Volatilization and oxidation of organic compounds via conveyance through high temperature.	√	√	Effective technology used to destroy explosives and hazardous wastes including chlorinated hydrocarbons, PCBs and dioxins.	Vendors are available.	High.	Not selected. Other more common, cost effective, and viable treatment technologies are available.
	Thermal	Low-Temperature Thermal Desorption	Wastes are heated to volatilize water and organic contaminants. A carrier gas transports volatilized water and organics to a gas treatment system.	√	√	Proven effective at reducing concentrations of petroleum products.	Vendors are available.	Moderate to high.	Not selected. Other more common, cost effective, and viable treatment technologies are available.
	Biological	Landfarming	Contaminated soil, sediment, or sludge is excavated, applied into lined beds and periodically turned over to aerate waste.	√		Moderate effectiveness at reducing organic concentrations. Technology is not effective on high concentration wastes.	Vendors are available.	Low to moderate.	Not selected. Limited effectiveness for target contaminant group.
	Biological	Slurry Phase Treatment	Treatment of contaminated material in a slurry reactor under controlled conditions using natural or cultured microorganisms to biodegrade organics.	√		Moderate effectiveness at reducing organic concentrations. Technology is not effective on high concentration wastes.	Vendors are available.	Moderate to high.	Not selected. Limited effectiveness for target contaminant group.
	Chemical	Oxidation	Use of strong oxidizers such as ozone, peroxide, chlorine, or permanganate to chemically oxidize materials.	√	√	Effective at destroying organics.	Vendors are available.	High.	Not selected. Other more common, cost effective, and viable treatment technologies are available.
	Chemical	Neutralization	Use of acids or bases to counteract excessive pH.			Not effective for site organics.	Vendors are available.	Low	Not selected. Not required based on site conditions.
	Solids Processing	Crushing and Grinding	Use of crushing and grinding to reduce the size of an object.			Common technology in association with excavation processes; well-proven and effective.	Vendors are available.	Low to moderate.	Not selected. Large rock is not expected at this site.
			Magnetic Separation	Separation of metal debris.		Effectively removes debris.	Vendors are available.	Low.	Not selected. Not required based on site conditions.
			Screening	Separation of material into fractions of the same size by passing through screens or mesh.		Effective method for separating out larger media during excavation activities.	Vendors are available.	Low.	Not selected. Large rock is not expected at this site.
In-Situ Treatment	Thermal	Steam Injection	Use of steam to heat contaminants to allow free product to form on the water table.	√	√	Process is proven effective specifically for sites with soils contaminated with light to dense organic liquids, coal tars, petroleum bi-products, etc.	Limited vendors are available.	Moderate.	Retained.
	Thermal	Hot Air Injection	Use of hot air to heat and volatilize contaminants.	√	√	This technology is applicable to semi-volatile organic compounds such as those present at the site. Bench scale treatability studies showed that air sparging soils resulted in a reduction of total PAH concentrations and TPH.	Limited vendors are available.	Moderate to high.	Not selected. Not as effective as steam injection or air sparging.

**TABLE 4-2
SCREENING OF TECHNOLOGIES AND PROCESS OPTIONS FOR SOIL
SITE 4 FORMER UST AREA
NWIRP BETHPAGE, NEW YORK
Page 4 of 4**

General Response Action	Remedial Technology	Process Options	Description	Chemical Class		Screening			
				PAHs	Free Product	Effectiveness	Implementability	Relative Cost	Screening comments
In-Situ Treatment	Thermal	Radio Frequency/ Electromagnetic/ Electrical Resistance Heating; Immersion Heaters	Use of radio waves, EM, electrical resistance, or immersion heaters to heat and volatilize contaminants.	√	√	Electrical resistance heating enhances the recovery of soils contaminated with volatile and semi-volatile organic compounds. Creates a source of steam to strip contaminants from soil.	Vendors are available.	Moderate to high.	Not selected. Not as cost effective as steam stripping.
	Biological	Biosparging	Air is injected into the groundwater to provide oxygen to promote aerobic degradation.	√		Biosparging has been proven to be relatively effective in treating soils contaminated by petroleum hydrocarbons and other organic chemicals. Not as effective on treating free product. The 2010 and 2011 bench scale studies showed that biosparging untreated soils resulted in a reduction of TPHs by up to 72% over a 60 day period.	Biosparging is becoming more common, and hardware required for remediation is readily available.	Moderate.	Retained.
		Nutrient enhanced biosparging	Air and nutrients (nitrogen and phosphorus) are injected into the groundwater to provide oxygen to promote aerobic degradation.	√		Enhanced biosparging techniques have been used to remediate soils contaminated with petroleum hydrocarbons, and requires relatively inexpensive inputs. Remediation is dependent upon a number of factors including ground temperature, soil content and soil moisture. Nutrient addition is considered when existing site conditions are nutrient deficient.	Vendors are available.	Low.	Not Selected. Although effective, air injection was proven effective during bench scale testing without addition of nutrients.
		Oxygen Releasing Compound (ORC)	ORC is injected into the saturated or unsaturated zones. Gradual release of oxygen promotes aerobic biological activity.	√		Are considered for low to moderate concentrations for organics.	Vendors are available.	Moderate to high.	Not selected. Not cost effective for high concentration organics.
	Physical	Soil Flushing/Solvent Extraction	Extraction of contaminants with suitable aqueous solutions. Extraction fluids are passed through in-place soils using an injection and infiltration process.	√	√	Moderately effective. Bench scale treatability studies showed that solvent extraction resulted in a reduction of total PAH concentrations.	Limited vendors are available.	Costs are moderate.	Retained.

TABLE 4-3
SUMMARY OF TECHNOLOGIES AND PROCESS OPTIONS RETAINED FOR DEVELOPMENT AND EVALUATION
SITE 4 FORMER UST AREA
NWIRP BETHPAGE, NEW YORK
Page 1 of 2

General Response Action	Remedial Technology	Process Options	Description	Area of Consideration
No Action	No Action	Not Applicable	No activities conducted at site to address contamination.	Not Applicable. Provides a basis of comparison to other process options.
Institutional Controls	Administrative restrictions	Land-Use Controls (LUCs)/ Deed Restrictions and Notices	Administrative action used to restrict groundwater use and future site activities.	Deed notifications will remain in place while contamination remains. May be combined with other remedial technologies.
	Monitoring/ Sampling	Performance and Compliance Monitoring	Sampling and analysis to evaluate the migration of contaminants within or the potential contamination of groundwater.	Will be implemented site-wide to monitor effectiveness of remedial technologies.
	Monitored Natural Attenuation (MNA)	Intrinsic process and Performance Monitoring	Natural attenuation (all mechanisms including biodegradation, advection-dispersion, dilution, etc.) coupled with regular monitoring as well as for other indicators of biodegradation.	Will be implemented site-wide, and may be combined with other technologies.
Removal	Removal - Solids	Bulk Excavation	Mechanical removal of solid materials using construction equipment.	Will be implemented in areas of contamination over 1,000 mg/Kg Total Petroleum Hydrocarbon (TPH) or 10,000 mg/Kg TPH.
	Free Product Recovery	Bioslurping	LNAPL removal is accomplished by combining steam injection and vacuum-enhanced free product recovery.	Will be implemented in areas of free product formation.
Disposal/Reuse	Landfill, Consolidation, Beneficial Reuse	Landfill, Consolidation, Beneficial Reuse	Excavated soils will either be disposed of, relocated on site, or reused on site.	Contaminated soil will be disposed of while clean soils will be reused in the excavation area as fill material.
	Beneficial Reuse	Reuse of Waste Oil	Waste oils recovered (i.e. TPH as free product) can be reused for asphalt plants or as fuel.	Recovered free product will be considered for reuse applications from all treatment alternatives.
Ex-Situ Treatment	Physical	Dewatering	Removal of free water from waste soils for disposal.	Will be implemented for saturated soils if excavation extends below the water table.
In-Situ Treatment	Thermal	Steam Injection	Use of steam to heat contaminants to allow free product to form on the water table.	Will be implemented in areas of contamination exceeding 1,000 mg/Kg TPH or 10,000 mg/Kg.
	Biological	Biosparging	Air is injected into the groundwater to provide oxygen to promote aerobic degradation.	Will be implemented in areas of contamination exceeding 1,000 mg/Kg TPH. Air injection wells will extend below the current water table.

**TABLE 4-3
SUMMARY OF TECHNOLOGIES AND PROCESS OPTIONS RETAINED FOR DEVELOPMENT AND EVALUATION
SITE 4 FORMER UST AREA
NWIRP BETHPAGE, NEW YORK
Page 2 of 2**

General Response Action	Remedial Technology	Process Options	Description	Area of Consideration
In-Situ Treatment cont.	Physical	Soil Flushing/Solvent Extraction	Extraction of contaminants with suitable aqueous solutions. Extraction fluids are passed through soils in place using an injection and infiltration process.	Will be implemented in areas of contamination exceeding 1,000 mg/Kg Total Petroleum Hydrocarbons (TPH).

TABLE 5-1
CRITERIA ANALYSIS FACTORS AND CONSIDERATIONS
SITE 4 (AOC 22)
NWIRP BETHPAGE, NEW YORK
Page 1 of 1

Corrective Measures Study (CMS) Evaluation Criteria	
Analysis Factor	Description
<i>Performance Standards</i>	
Attain Media Cleanup Standards	Discusses achievement of preliminary remediation goals (PRGs) and the time to achieve these goals.
Source Control	Discusses the elimination of source areas.
Protection of Human Health and the Environment	Describes how the alternative reduces risk to human health through contaminant exposure, reduces the threat to previously unaffected environmental media, and reduces the risk to ecological receptors.
<i>Balancing Factors</i>	
Long-term Reliability and Effectiveness	Discusses how the alternative manages future site risks during the period after the remedial action is complete.
Reduction of Toxicity, Mobility, Volume	Discusses the treatment process involved with the alternative. Quantifies the amount of hazardous material treated, the scope of action taken to mitigate original risks, risks associated with treatment, and remaining residuals.
Short-term Effectiveness	Discusses how the alternative manages site risks during construction and implementation of the alternative.
Implementability	Discusses the technical and administrative feasibility of constructing, operating, and maintaining a remedial action alternative.
Cost	Evaluates both capital and operation and maintenance costs.
State and Community Acceptance ⁽¹⁾	Public and regulatory acceptance of the alternative.
Feasibility Study (FS) 9 National Oil and Hazardous Substances Pollution Contingency Plan (NCP) Criteria	
Analysis Factor	Description
<i>Threshold Criteria</i>	
Protection of Human Health and the Environment	Describes how the alternative reduces risk to human health through contaminant exposure, reduces the threat to previously unaffected environmental media, and reduces the risk to ecological receptors.
Compliance with Applicable or Relevant and Appropriate Requirements (ARARs)	Verifies that the alternative meets chemical, action, and location-specific ARARs (as described in Section 3).
<i>Primary Balancing Criteria</i>	
Long-term Effectiveness and Permanence	Discusses how the alternative manages future site risks during the period after the remedial action is complete.
Reduction of Toxicity, Mobility, Volume	Discusses the treatment process involved with the alternative. Quantifies the amount of hazardous material treated, the scope of action taken to mitigate original risks, risks associated with treatment, and remaining residuals.
Short-term Effectiveness	Discusses how the alternative manages site risks during construction and implementation of the alternative.
Implementability	Discusses the technical and administrative feasibility of constructing, operating, and maintaining a remedial action alternative.
Cost	Evaluates both capital and operation and maintenance costs.
<i>Modifying Criteria⁽¹⁾</i>	
State Acceptance	Regulatory acceptance of the alternative.
Community Acceptance	Public acceptance of the alternative.

Notes:

Note that CMS and FS evaluation criteria are nearly the same.

⁽¹⁾Public and regulatory acceptance of the alternative is evaluated in detail after the public comment period on the FS/CMS.

TABLE 5-2
MONITORED NATURAL ATTENUATION PERFORMANCE MONITORING OBJECTIVES
SITE 4 (AOC 22)
NWIRP BETHPAGE, NEW YORK
Page 1 of 1

MNA Objective	Evaluation for Site 4 Soils
1 Demonstrate that natural attenuation is occurring according to expectations.	Section 2.5 describes the current extent of contamination at Site 4. PAHs are the COPCs for subsurface soils. COPCs in groundwater include select metals, petroleum derivative VOCs, and SVOCs. This shows that remaining free product is acting as a continuing source, and remedial actions must address this possibility.
2 Detect Changes in environmental conditions (e.g. hydrogeologic, geochemical, or microbiological) that may reduce the efficacy of any of the natural attenuation processes.	None detected during recent investigations. Groundwater containment wells line the south end of this Navy property and may impact site hydrogeology.
3 Identify any potentially toxic and/or mobile transformation products.	Petroleum derivative and PAH degradation is slower under anaerobic conditions. Hydrocarbons are not exposed to the atmosphere, and are expected to remain for long periods of time.
4 Verify that contamination is not expanding downgradient, laterally, or vertically.	Except for pentachlorophenol in one downgradient well (MW06), there is no evidence of migration of organics beyond the source area.
5 Verify no unacceptable impact to downgradient receptors.	There is no current evidence of migration of organics beyond the source area. LUCs would remain while contamination is still in place.
6 Detect new releases of contaminants to the environment that could impact the effectiveness of the natural attenuation remedy.	Remaining free product may be acting as a continuing source (wells MW01, MW02).
7 Demonstrate the efficacy of institutional controls that were put in place to protect potential receptors.	LUCs would be implemented as part of this remedy.
8 Verify attainment of remediation objectives	Attainment of remedial objectives would be evaluated throughout the MNA process. The remedy will be considered complete when the data show cleanup levels have been met.

**TABLE 5-3
COMPARATIVE ANALYSIS OF ALTERNATIVES
SITE 4 (AOC 22)
NWIRP BETHPAGE, NEW YORK
Page 1 of 3**

Criteria	Alternative 1 - No Action	Alternative 2 - Monitored Natural Attenuation (MNA) and Land- Use Controls (LUCs)	Alternative 3 - Steam Injection and Free Product Recovery	Alternative 4 - Biosparging with Steam Injection and Free Product Recovery	Alternative 5 - Solvent Extraction with Biosparging and Free Product Recovery	Alternative 6A - Full Excavation	Alternative 6B - Partial Excavation
Overall Protection of Human Health and the Environment	Not protective of human health and the environment. Does not meet Remedial Action Objectives (RAOs). Contaminated site soil can be used elsewhere and potable use of groundwater could result in risk.	This alternative is expected to meet RAOs through Land Use Control (LUCs) to restrict use of contaminated site soils and groundwater, inspections, and monitoring of soil and groundwater. Polynuclear aromatic hydrocarbons contained within total petroleum hydrocarbons (TPH) would naturally degrade and possible migration to groundwater would be monitored.	This alternative is protective of human health and the environment through the use of steam injection and free product recovery to remove the majority of TPH. Residual contaminants in soil and groundwater would be addressed through attenuation. LUCs and would be in place while contamination remains.	Same as Alternative 3, except that biosparging would be used to accelerate biodegradation of residual soil and groundwater contamination.	Same as Alternative 4, except that insitu solvent extraction would be used in place of steam injection.	This alternative is protective of human health and the environment by removing the contaminated soil and disposing or reusing it offsite. LUCs and groundwater monitoring would be conducted while residual groundwater contamination remains.	Same as Alternative 4, except only the most contaminated soil would be removed and additional soil monitoring would be required.
Compliance with ARARs	Does not comply with the chemical-specific ARARs of NYSDEC Soil Cleanup Objectives, Federal EPA RSL values, NYSDOH MCLs for groundwater or Federal drinking water standards. No location- or action-specific ARARs.	Complies with ARARs.	Complies with ARARs	Complies with ARARs	Complies with ARARs	Complies with ARARs	Complies with ARARs
Long-term Effectiveness and Permanence	Not effective in the long term. Contaminated soils could continue to leach to groundwater and impact potable water supplies. PAHs in groundwater exceed PRGs and pose a risk to human health. No controls in place to monitor potential effects.	Alternative would be protective and permanent in the long term.	Same as Alternative 2.	Same as Alternative 2.	Same as Alternative 2.	Same as Alternative 2.	Same as Alternative 2.
Reduction of Toxicity, Mobility or Volume Through Treatment	No reduction through treatment. PAHs and TPH in soils would degrade through natural biological activity.	No reduction through treatment. Minor quantities of contaminated soil and groundwater would be generated during monitoring activities.	Thermal treatment/free product recovery to remove approximately 9,100 gallons (37 tons) of TPH over four years for offsite disposal/reuse. An additional 10 tons of TPH would degrade through attenuation.	Thermal treatment/free product will remove approximately 7,900 gallons (33 tons) of TPH over two years of operation for offsite disposal/reuse and biosparging will degrade approximately 14 tons of TPH over four years.	Free product removal through solvent extraction will remove approximately 9,800 gallons (41 tons) of TPH during operation. Residual solvent and 6 tons of contamination will be degraded by biosparging.	No reduction through treatment. Approximately 7,000 cubic yards of soil contaminated with 47 tons of TPH would be removed from the site through full excavation.	No reduction through treatment. Approximately 1,400 cubic yards of soil contaminated with 30 tons of TPH would be removed from the site through excavation.

**TABLE 5-3
COMPARATIVE ANALYSIS OF ALTERNATIVES
SITE 4 (AOC 22)
NWIRP BETHPAGE, NEW YORK
Page 2 of 3**

Criteria	Alternative 1 - No Action	Alternative 2 - Monitored Natural Attenuation (MNA) and Land- Use Controls (LUCs)	Alternative 3 - Steam Injection and Free Product Recovery	Alternative 4 - Biosparging with Steam Injection and Free Product Recovery	Alternative 5 - Solvent Extraction with Biosparging and Free Product Recovery	Alternative 6A - Full Excavation	Alternative 6B - Partial Excavation
Short-term Effectiveness	Not effective in the short term. Contamination will remain and possibly continue to leach to groundwater.	LUCs, in combination with monitoring, would be protective while contamination remains. PRGs would not be achieved until 30 or more years.	Potential controlled exposure to workers during remediation. Extracted groundwater and vapors must be treated prior to discharge. LUCs would be protective while contamination remains. PRGs would be obtained in approximately 16 years through free product removal (4 years) and natural attenuation of residual contamination (12 additional years).	Potential controlled exposure to workers during remediation. Extracted groundwater and vapors must be treated prior to discharge. LUCs would be protective while contamination remains. PRGs would be obtained in approximately 10 years through free product removal (2 years), biosparging (4 years), and natural attenuation of residual contamination (6 years).	Same as Alternative 4.	Potential controlled exposure to workers during remediation and community during waste transport. PRGs will be obtained in approximately 4 years. The excavation will require approximately 2 years to complete and attenuation of residual contamination in the groundwater will require an additional 2 years to complete.	Same as Alternative 6A, except attenuation of residual soil and groundwater contamination will require approximately 12 years.
Implementability	Easy to implement.	Easy to implement.	Moderately difficult to implement. Vendors and equipment are available, but steam injection vendors are less common. Permit equivalents for air and groundwater discharge will be required.	Same as Alternative 3. Vendors are readily available for biosparging technology.	May be difficult to implement. Vendors are readily available for biosparging technology. No vendors have been identified for the solvent extraction component. The permitting process for solvent injection is uncertain.	May be difficult to implement. Excavation of soils below the water table in permeable running sands can be technically challenging.	Same as Alternative 6A.
Cost	\$0	Capital: \$30,000 O&M: \$35,000 to \$85,000 per year (30 years) PV: \$1,100,000	Capital: \$1,800,000 O&M: \$35,000 to \$320,000 per year (16 years) PV: \$3,400,000	Capital: \$1,800,000 O&M: \$35,000 to \$350,000 per year (10 years) PV: \$2,900,000	Capital: \$1,600,000 O&M: \$35,000 to \$840,000 per year (10 years) PV: \$3,700,000	Capital: \$7,800,000 O&M: \$35,000 - \$65,000 per year (4 years) PV: \$8,000,000	Capital: \$4,100,000 O&M: \$35,000 to \$65,000 per year (12 years) PV: \$4,500,000
Media Cleanup Standards	Does not achieve PRGs.	PRGs would not be achieved until 30 or more years..	PRGs would be obtained in approximately 16 years through free product removal and natural attenuation of residual contamination.	PRGs would be obtained in approximately 10 years through free product removal (2 years), biosparging (4 years), and natural attenuation of residual contamination (6 years).	Same as Alternative 4.	PRGs will be obtained in approximately 4 years. The excavation will require approximately 2 years to complete and attenuation of residual contamination in the groundwater will require an additional 2 years to complete.	Same as Alternative 6A, except attenuation of residual soil and groundwater contamination will require approximately 12 years
Source Control	No source area control.	Same as Alternative 1.	This alternative actively remediates the source of contamination through free product removal.	This alternative actively remediates the source of contamination through free product removal and biodegradation of contamination.	This alternative actively remediates the source of contamination through free product removal and biodegradation of remaining solvent and contamination.	The source is eliminated through removal.	This alternative actively remediates the source of contamination through removal; and addresses residual contamination through monitoring.

**TABLE 5-3
COMPARATIVE ANALYSIS OF ALTERNATIVES
SITE 4 (AOC 22)
NWIRP BETHPAGE, NEW YORK
Page 3 of 3**

Criteria	Alternative 1 - No Action	Alternative 2 - Monitored Natural Attenuation (MNA) and Land- Use Controls (LUCs)	Alternative 3 - Steam Injection and Free Product Recovery	Alternative 4 - Biosparging with Steam Injection and Free Product Recovery	Alternative 5 - Solvent Extraction with Biosparging and Free Product Recovery	Alternative 6A - Full Excavation	Alternative 6B - Partial Excavation
Waste Management Standards	No wastes generated.	Non-hazardous Investigative Derived Wastes (IDW) are generated.	Non-hazardous IDW wastes including water blowdown, treated groundwater and air, free product, and GAC.	Same as Alternative 3.	Non-hazardous IDW wastes generated. Free product and Vertec will be recycled or disposed of.	Waste soils will be disposed in a permitted facility. Soils are not expected to be hazardous. Non-hazardous IDW wastes are also generated.	Same as Alternative 6A.

Notes

O & M - Operation and maintenance

ARARs - Applicable, Relevant, and Appropriate Requirements

PRGs - Preliminary Remediation Goals

1 - State and Community Acceptance are to be determined based on a review of this FS/CMS and development of a Proposed Remedial Action Plan and Statement of Basis.

RAOs - Remedial Action Objectives

PV - Present value

IDW - Investigation derived waste

**TABLE 5-4
SUMMARY OF COSTS
Site 4 – FEASIBILITY STUDY
NWIRP BETHPAGE, NEW YORK**

Alternative	Capital Cost	O&M, Monitoring, and Five-year Review Costs	Present Value of Alternative (Capital plus O&M Costs)
Alternative 1 - No Action	\$0	None	\$0
Alternative 2 - Limited Action and Monitored Natural Attenuation	\$30,000	Annual Groundwater Sampling: \$35,000/Year (30 years) Soil Sampling: \$50,000/10 years (30 years) Five-year Review: \$30,000/5 years (30 years)	\$1,100,000
Alternative 3 - Steam Injection/ Free Product Recovery	\$1,800,000	Steam Injection/Free Product Recovery: \$210,000/Year (4 years) Annual Groundwater Sampling: \$35,000/Year (16 years) Soil Sampling: \$51,000/8 years (16 years) Five-year Review: \$30,000/5 years (16 years)	\$3,400,000
Alternative 4 - Biosparge Treatment with Limited Free Product Recovery	\$1,800,000	Steam Injection/Free Product Recovery: \$200,000/Year (2 years) Biosparging: \$39,000/Year (4 years) Annual Groundwater Sampling: \$35,000/Year (10 years) Soil Sampling: \$51,000/2 years (4 years) Five-year Review: \$30,000/5 years (10 years)	\$2,900,000
Alternative 5 -Solvent Extraction and Biosparging	\$1,600,000	Solvent Injection/Product Recovery: \$680K/Year (2 years) Biosparging: \$39,000/Year (4 years) Annual Groundwater Sampling: \$35,000/Year (10 years) Soil Sampling: \$51,000/2 years (4 years) Five-year Review: \$30,000/5 years (10 years)	\$3,700,000
Alternative 6A - Excavation TPH greater than 1,000 mg/Kg	\$7,800,000	Annual Groundwater Sampling: \$35,000/Year (4 years) Five-year Review: \$30,000/5 years (5 years)	\$8,000,000
Alternative 6B - Excavation TPH greater than 10,000 mg/Kg	\$4,100,000	Annual Groundwater Sampling: \$35,000/Year (12 years) Five-year Review: \$30,000/5 years (12 years)	\$4,500,000

TPH – Total petroleum hydrocarbons
mg/kg – milligram per kilogram

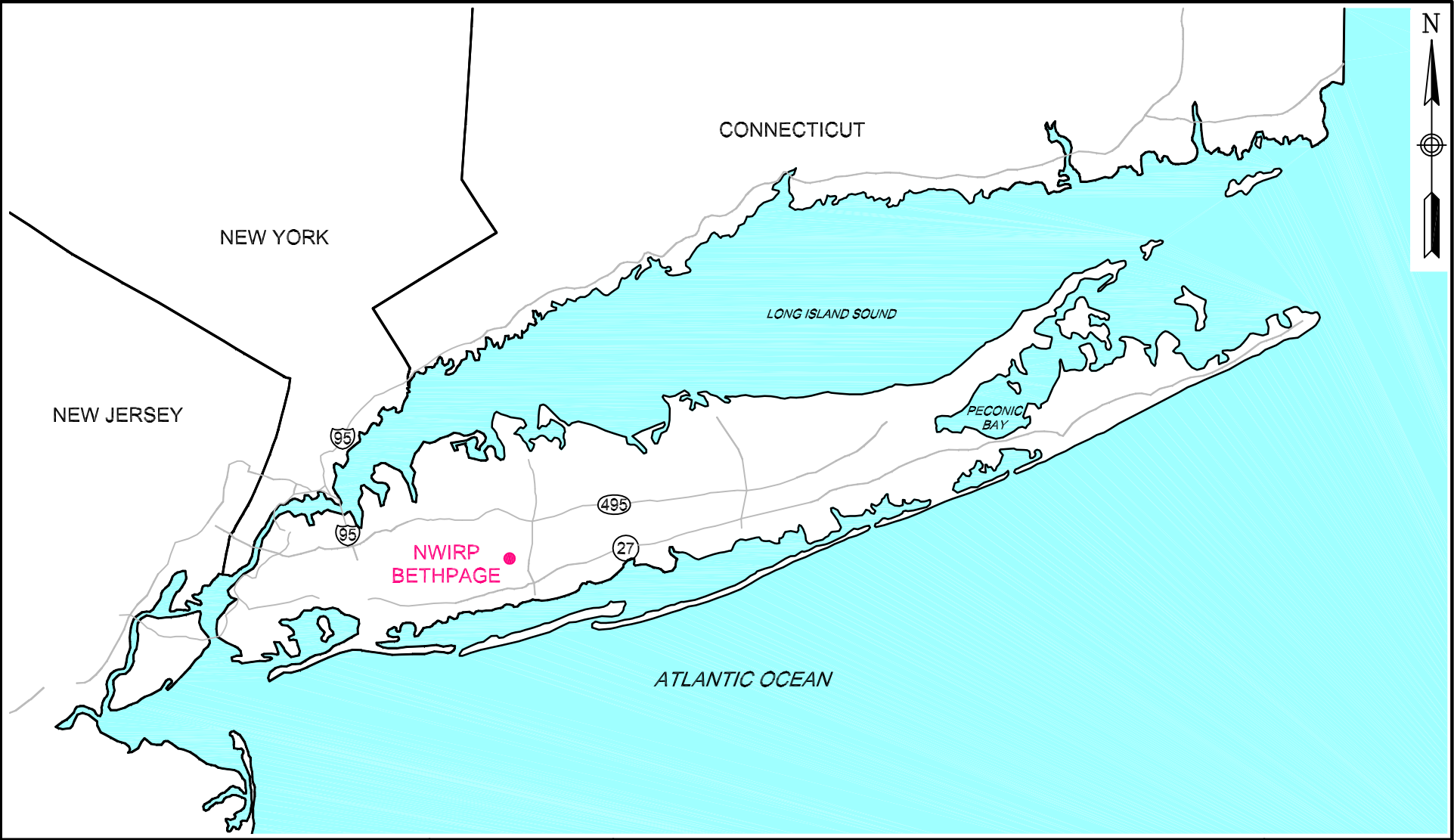

GENERAL LOCATION MAP
NWIRP BETHPAGE
BETHPAGE, NEW YORK

SCALE NOT TO SCALE	
FILE 112G02751CM01	
REV 0	DATE 11/26/12
FIGURE NUMBER FIGURE 1-1	

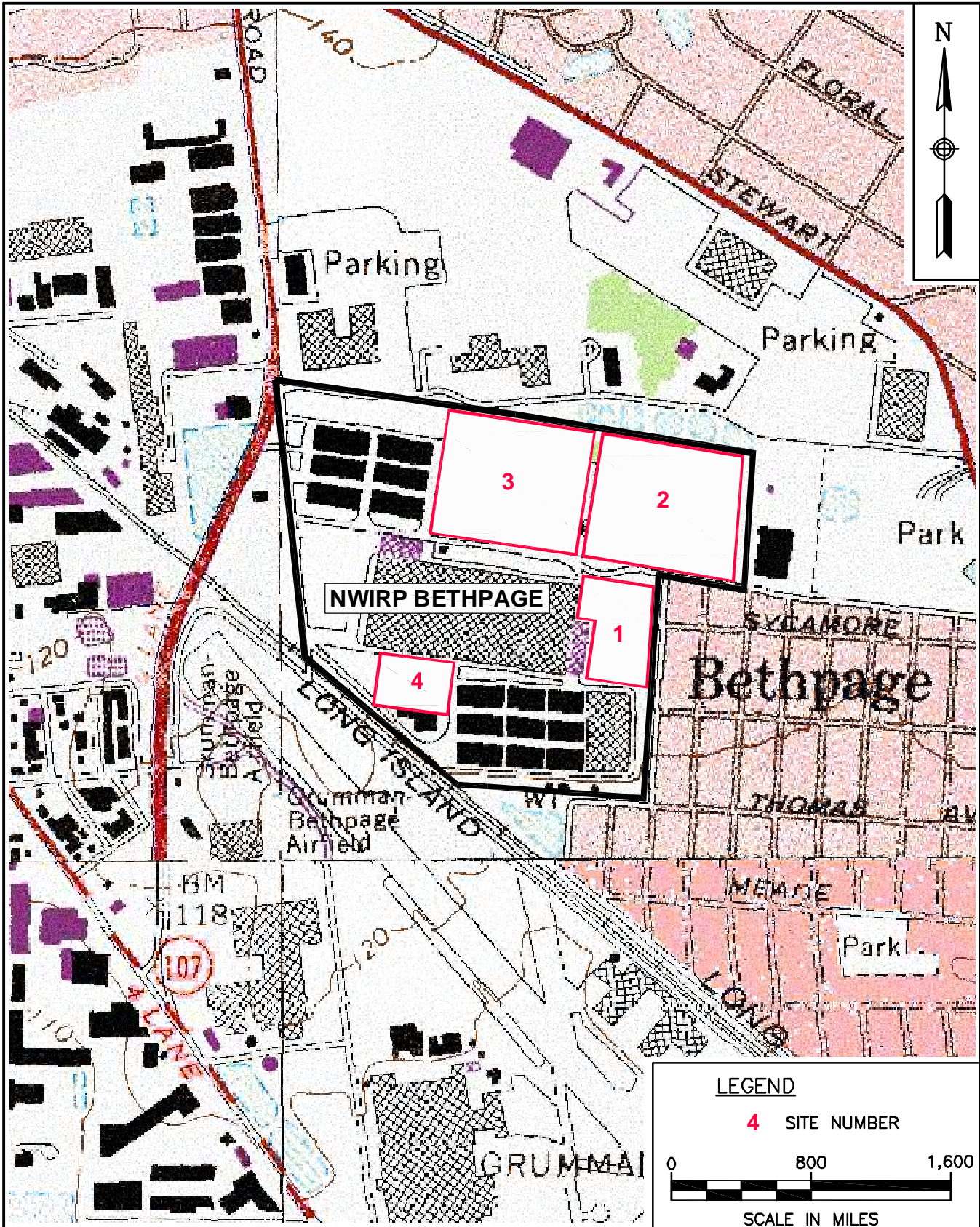

SITE LOCATION MAP
 AOC 22/SITE 4
 NWIRP BETHPAGE
 BETHPAGE, NEW YORK

SCALE AS NOTED	
FILE 112G02751BM02	
REV 0	DATE 08/01/12
FIGURE NUMBER FIGURE 1-2	



SITE 4 LAYOUT
 AOC 22 (FORMER USTs)
 NWIRP BETHPAGE
 BETHPAGE, NEW YORK

FILE 112G02751GM07	SCALE AS NOTED
FIGURE NUMBER FIGURE 2-1	REV DATE 0 01/30/13

LEGEND



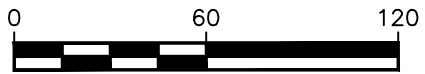

 SITE BOUNDARY

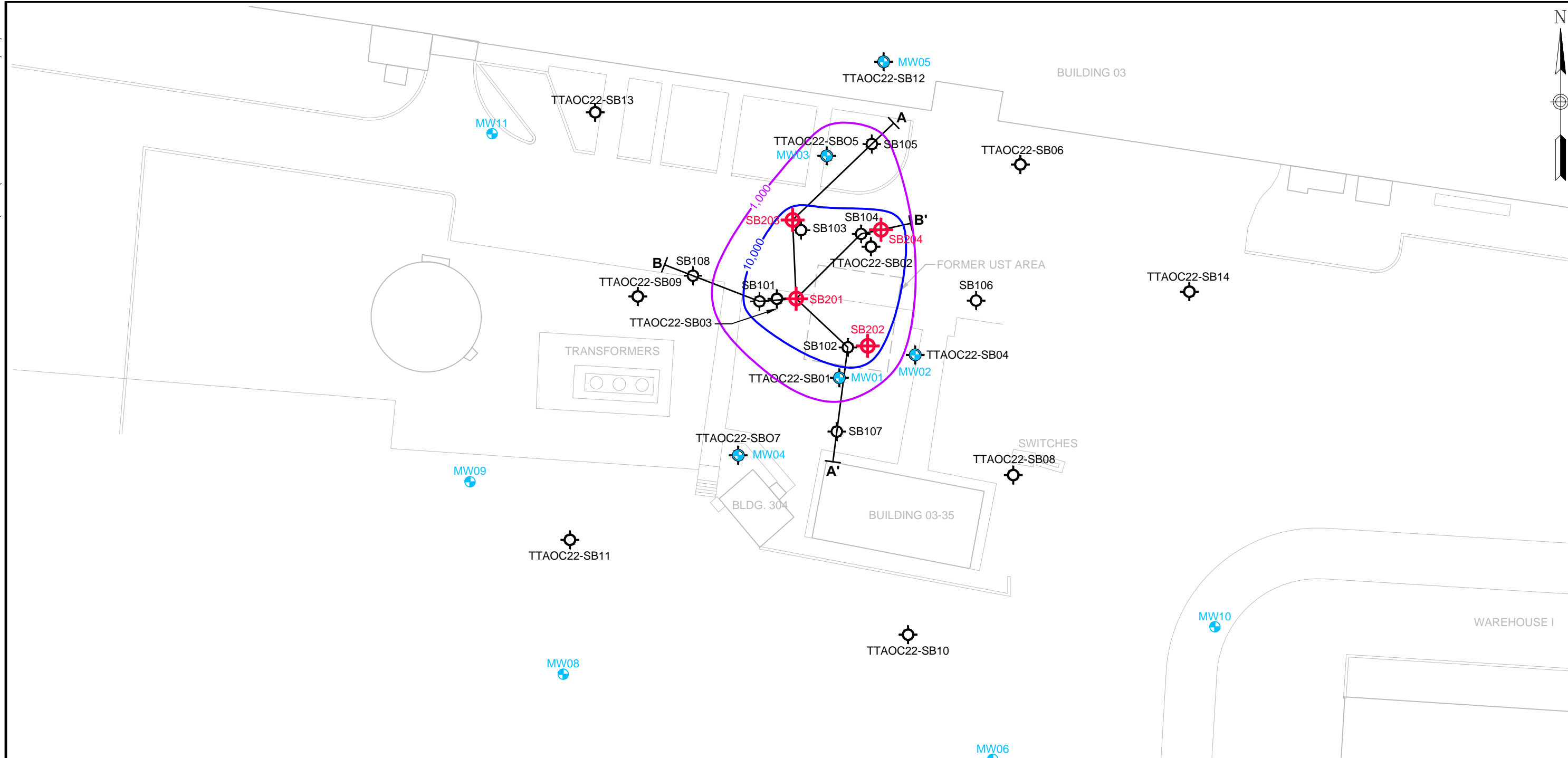



SCALE IN FEET

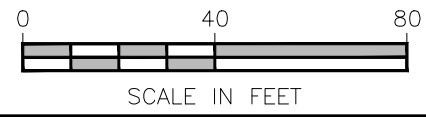

LEGEND

-  EXISTING MONITORING WELL LOCATION
-  PREVIOUS SOIL BORING LOCATION
-  NOVEMBER 2010 SOIL BORING LOCATION
-  SOIL CONTAMINATION IN MILLIGRAMS PER KILOGRAM (mg/kg)
TOTAL PETROLEUM HYDROCARBONS (TPH)



 TETRA TECH	
AREAL EXTENT OF CONTAMINATION SITE 4 NWIRP BETHPAGE, NEW YORK	
FILE 112G02751GM01-5	SCALE AS NOTED
FIGURE NUMBER FIGURE 2-2	REV DATE 0 01/30/13

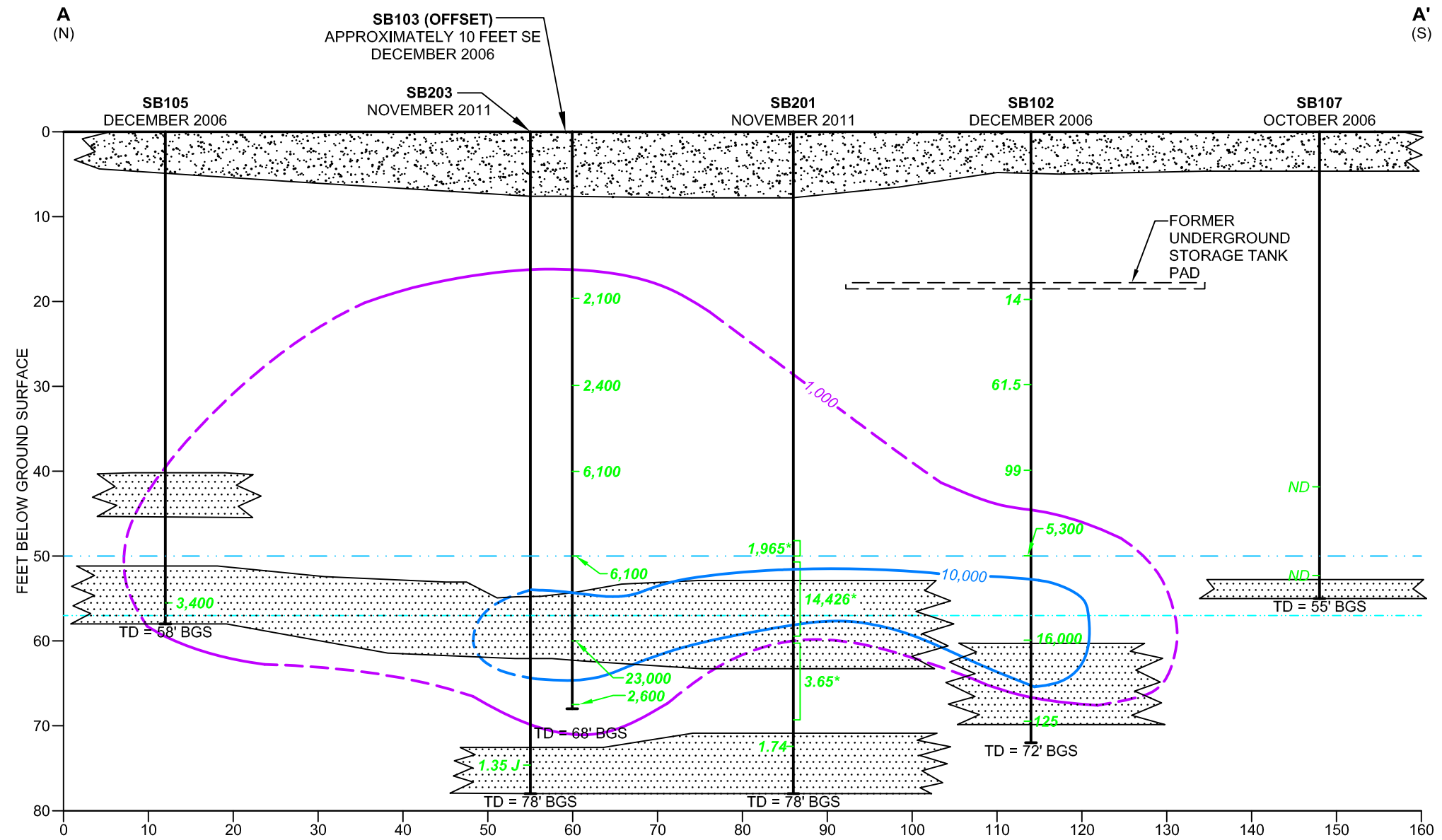

LEGEND

- GRAVEL/ASPALT
- FINE TO COARSE SAND WITH TRACE CLAY, GRAVEL AND SILT
- SILTY SAND
- 1999 WATER TABLE ~57 FEET BGS
- 2011 WATER TABLE ~50 FEET BGS
- TPH (1,000 mg/kg CONTOUR LINE) (DASHED WHERE INFERRED)
- TPH (10,000 mg/kg CONTOUR LINE) (DASHED WHERE INFERRED)

- SB102** SOIL BORING
- * AVERAGE TPH CONCENTRATION FROM SB201 AND SB204
- 5,300 TPH RESULT IN MILLIGRAMS PER KILOGRAM (mg/kg)
- TD = 58' BGS TOTAL DEPTH (BGS) BELOW GROUND SURFACE
- ND NOT DETECTED
- TPH TOTAL PETROLEUM HYDROCARBONS

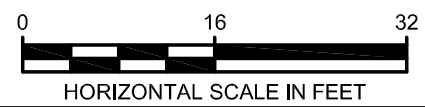

**VERTICAL EXTENT OF CONTAMINATION
 CROSS SECTION A - A'
 SITE 4
 NWIRP
 BETHPAGE, NEW YORK**

FILE 112G02751GS02-1	SCALE AS NOTED
FIGURE NUMBER FIGURE 2-3	REV DATE 0 11/28/12

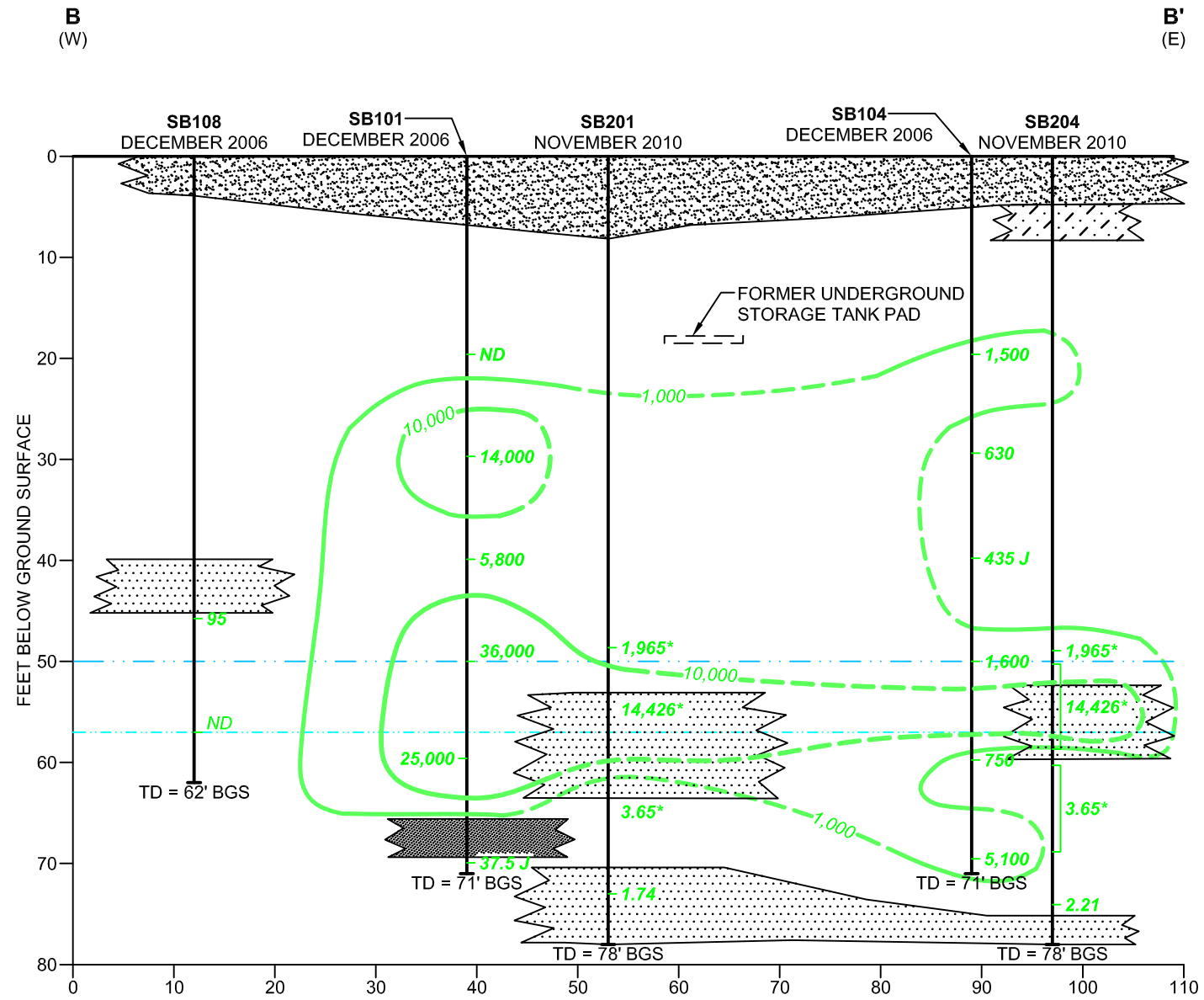

LEGEND

- SAND WITH GRAVEL/ASPHALT/CONCRETE
- FINE TO COARSE SAND WITH TRACE CLAY, GRAVEL AND SILT
- SILTY SAND
- CLAYEY SILT
- CLAYEY SAND

- SB102** SOIL BORING
- * AVERAGE TPH CONCENTRATION FROM SB201 AND SB204
- 5,300 TPH RESULT IN MILLIGRAMS PER KILOGRAM (mg/kg)
- TD = 58' BGS TOTAL DEPTH (BGS) BELOW GROUND SURFACE
- ND NOT DETECTED
- TPH TOTAL PETROLEUM HYDROCARBONS

- 1999 WATER TABLE ~57 FEET BGS
- 2011 WATER TABLE ~50 FEET BGS
- TPH (1,000 mg/kg CONTOUR LINE) (DASHED WHERE INFERRED)
- TPH (10,000 mg/kg CONTOUR LINE) (DASHED WHERE INFERRED)

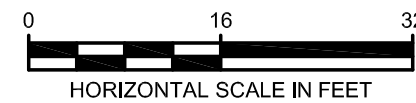

**VERTICAL EXTENT OF CONTAMINATION
CROSS SECTION B - B'
SITE 4
NWIRP
BETHPAGE, NEW YORK**

FILE
112G02751GS02-1

SCALE
AS NOTED

FIGURE NUMBER
FIGURE 2-4

REV DATE
0 11/28/12

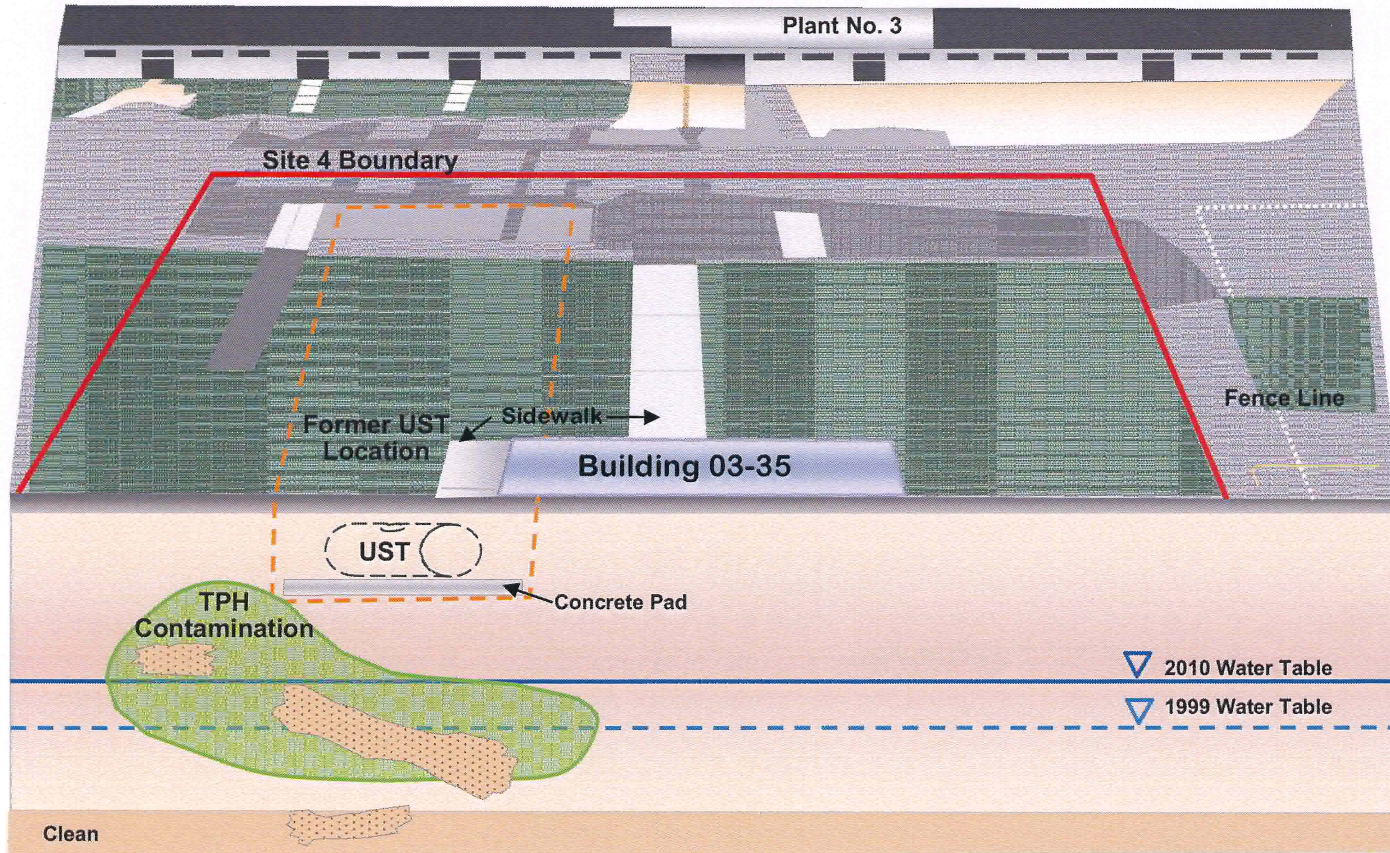

DRAWN BY C. Pennington	DATE 04-18-11
CHECKED BY	DATE
REVISED BY	DATE
SCALE NOT TO SCALE	



CONCEPTUAL SITE MODEL
AOC 22/SITE 4
NWIRP BETHPAGE
BETHPAGE, NEW YORK

CONTRACT NO.	
OWNER NO.	
APPROVED BY	DATE
DRAWING NO. FIGURE 2-5	REV.

LEGEND			
	Water Table		Site Boundary
	TPH Contaminant		Silty Sand
	Clean Soil		Sand

**FIGURE 2-6
CONCEPTUAL SITE MODEL EXPOSURE PATHWAYS
NWIRP BETHPAGE, NEW YORK
Page 1 of 1**

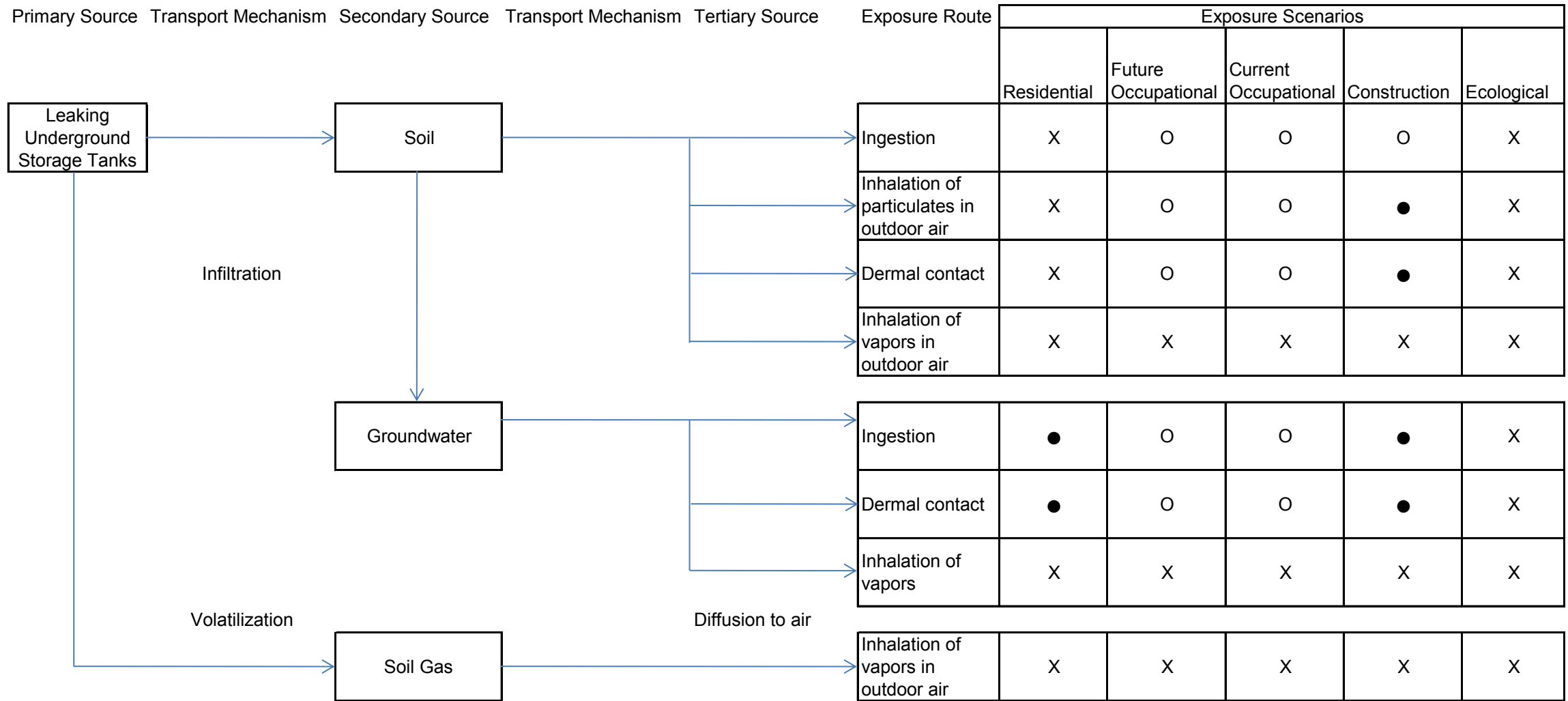

LEGEND:

- Potentially complete exposure pathway
- O Not considered a significant source of exposure
- X Incomplete exposure pathway

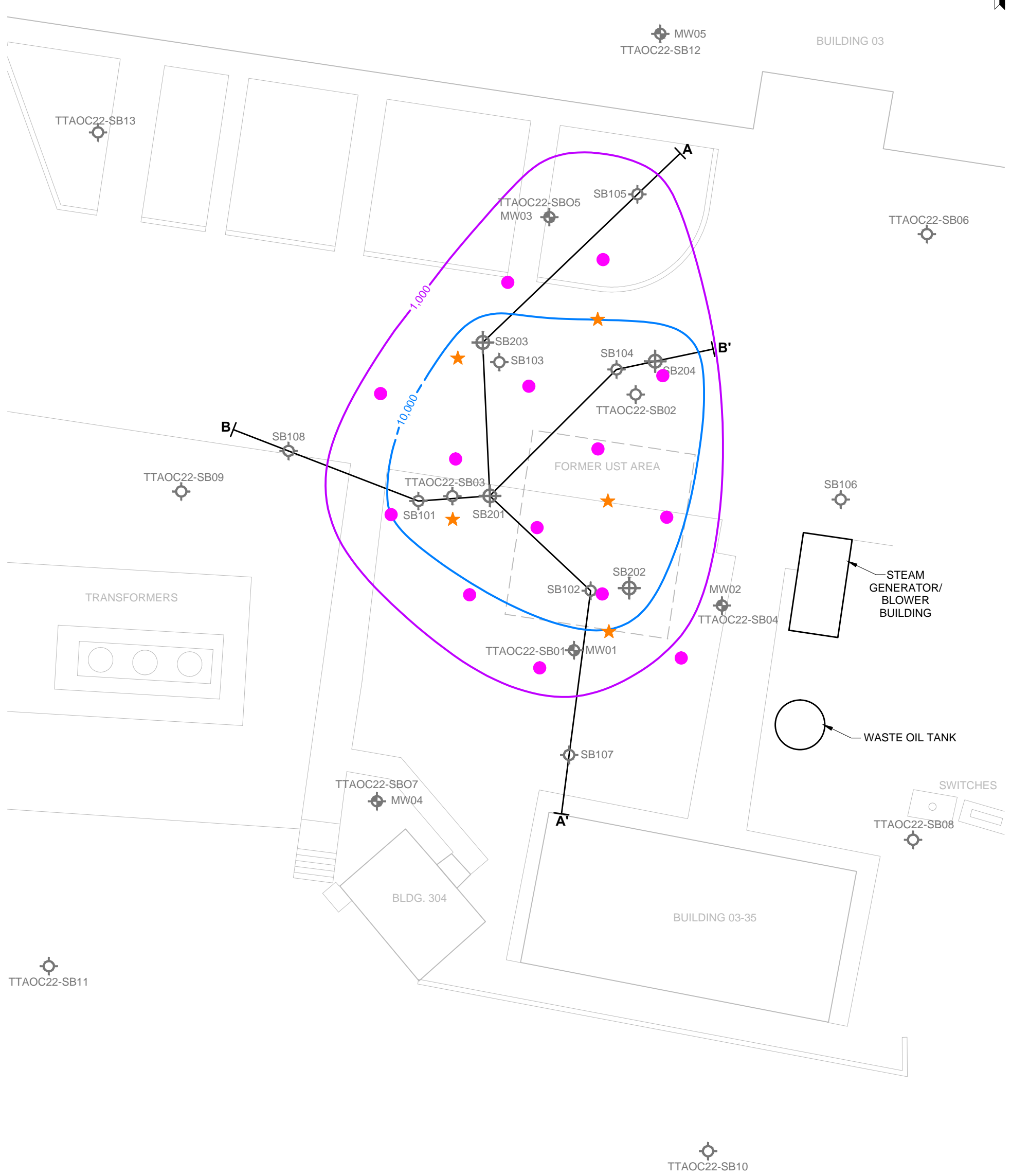
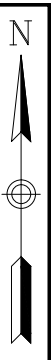

- LEGEND**
- STEAM INJECTION WELL, 14 CLUSTERS - 28 WELLS
 - ★ FREE PRODUCT RECOVERY WELL, 5 WELLS
 - EXISTING MONITORING WELL LOCATION
 - PREVIOUS SOIL BORING LOCATION
 - NOVEMBER 2010 SOIL BORING LOCATION
 - SOIL CONTAMINATION IN MILLIGRAMS PER KILOGRAM (mg/kg) TOTAL PETROLEUM HYDROCARBONS (TPH)

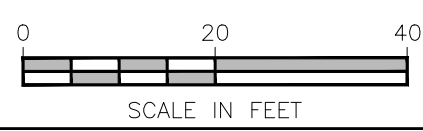

TETRA TECH	
ALTERNATIVE 3: STEAM INJECTION AND FREE PRODUCT RECOVERY CONCEPTUAL LAYOUT	
SITE 4 NWIRP	
BETHPAGE, NEW YORK	
FILE 112G02751GM05-1	SCALE AS NOTED
FIGURE NUMBER FIGURE 5-1A	REV DATE 0 01/30/13

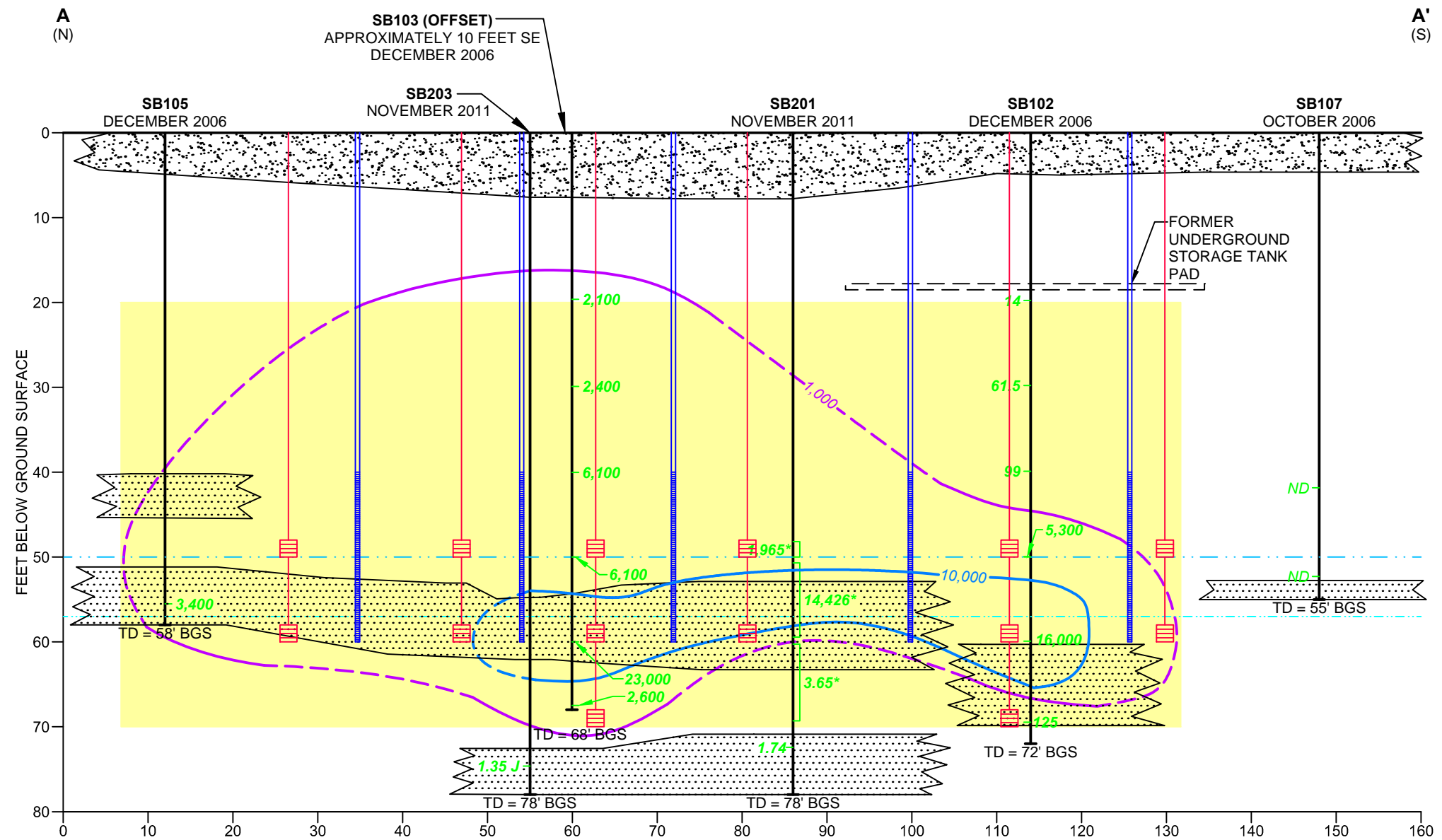

LEGEND

- GRAVEL/ASPHALT
- FINE TO COARSE SAND WITH TRACE CLAY, GRAVEL AND SILT
- SILTY SAND
- 1999 WATER TABLE ~57 FEET BGS
- 2011 WATER TABLE ~50 FEET BGS
- 1,000 TPH (1,000 mg/kg CONTOUR LINE) (DASHED WHERE INFERRED)
- 10,000 TPH (10,000 mg/kg CONTOUR LINE) (DASHED WHERE INFERRED)
- SB102** SOIL BORING
- * AVERAGE TPH CONCENTRATION FROM SB201 AND SB204
- 5,300 TPH RESULT IN MILLIGRAMS PER KILOGRAM (mg/kg)
- TD = 58' BGS TOTAL DEPTH (BGS) BELOW GROUND SURFACE
- ND NOT DETECTED
- TPH TOTAL PETROLEUM HYDROCARBONS
- STEAM INJECTION WELL
- FREE PRODUCT RECOVERY WELL
- TARGET AREA OF STEAM INJECTION HEATING



ALTERNATIVE 3: STEAM INJECTION AND FREE PRODUCT RECOVERY CONCEPTUAL CROSS SECTION VIEW SITE 4 NWIRP BETHPAGE, NEW YORK

FILE 112G02751GS02-2

SCALE AS NOTED

FIGURE NUMBER **FIGURE 5-1B**

REV 0 DATE 01/30/13

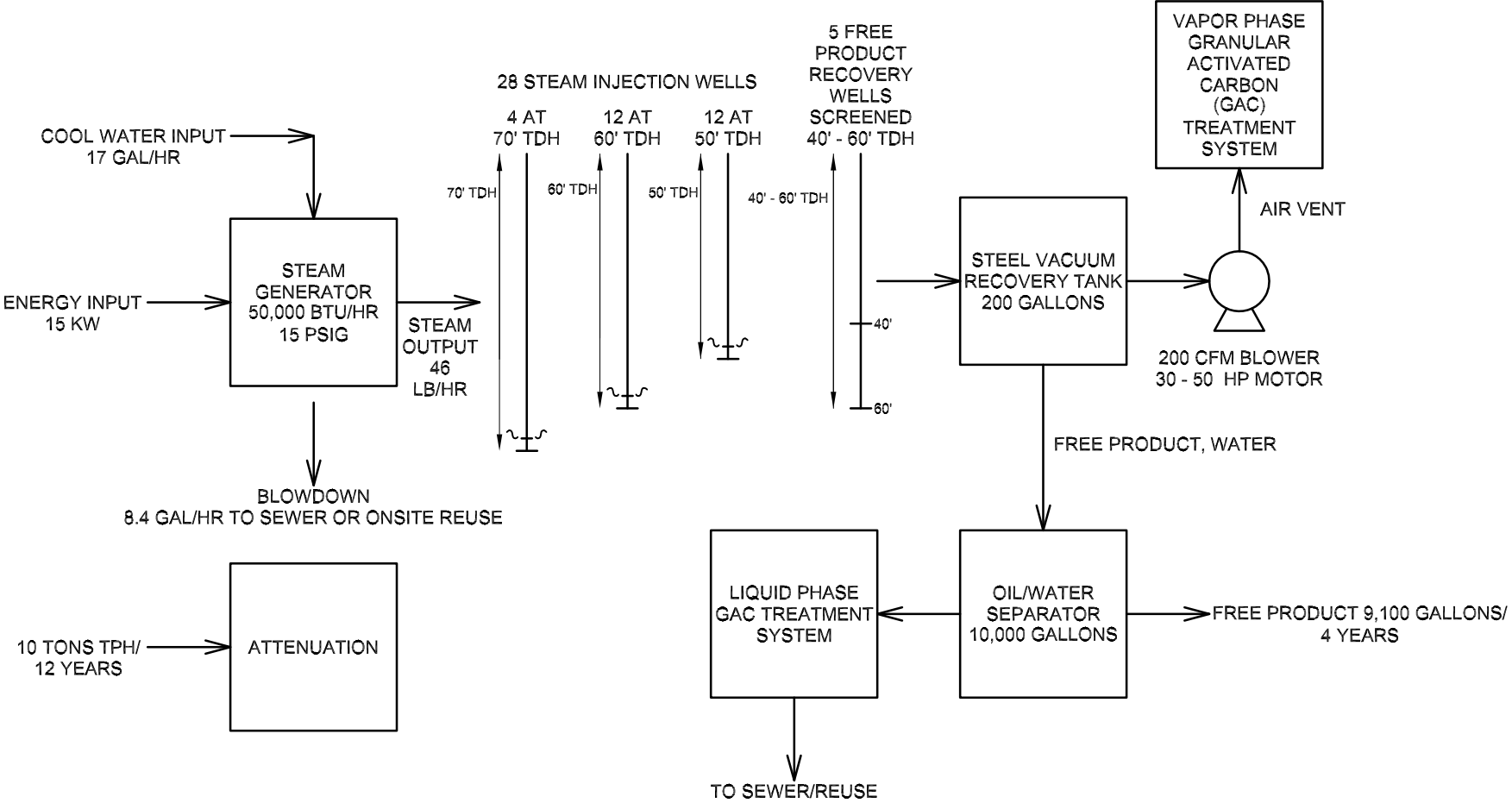





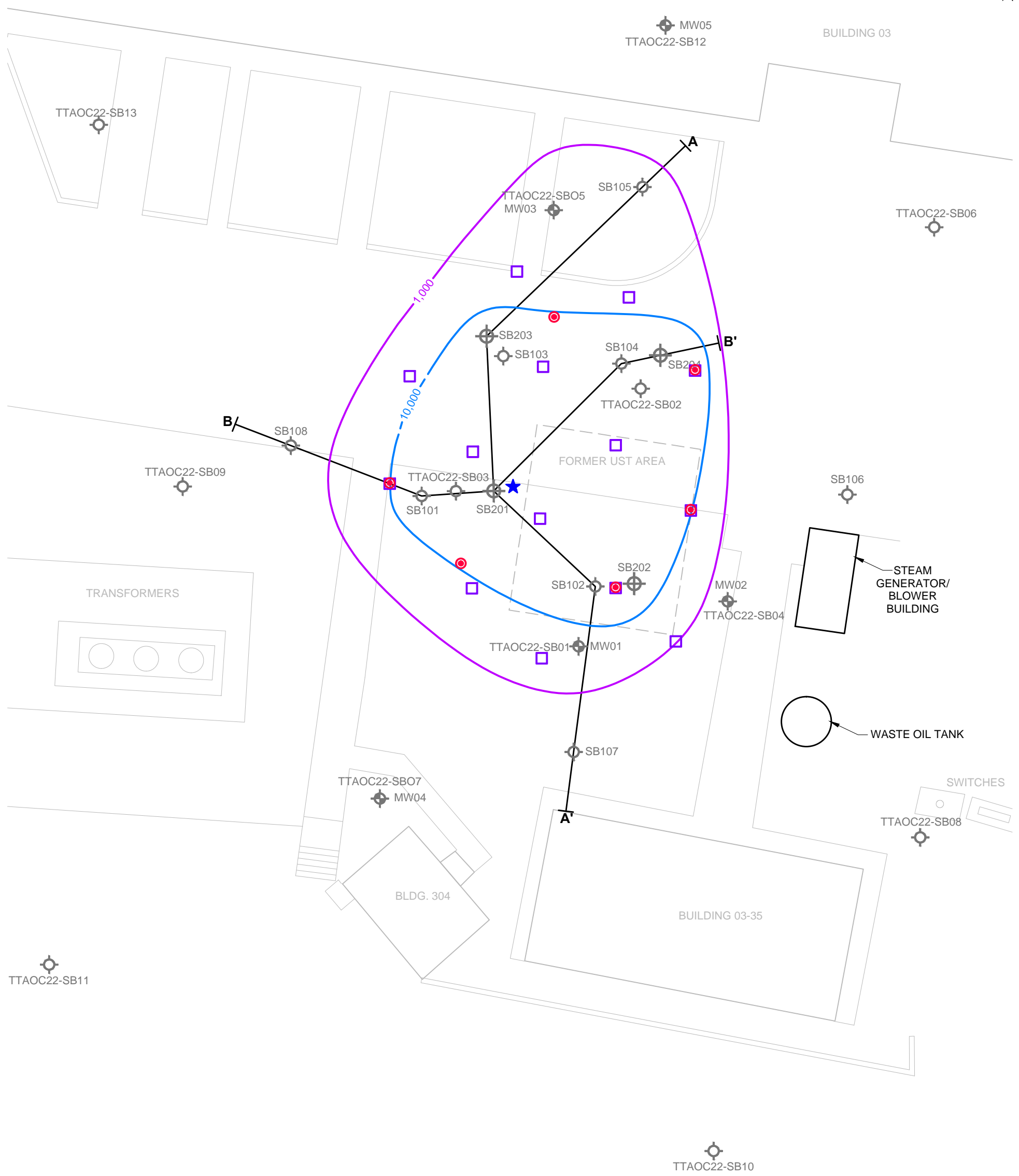
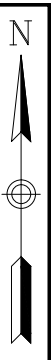

SCHEMATIC: NOT TO SCALE

 TETRA TECH	ALTERNATIVE 3 STEAM INJECTION AND FREE PRODUCT RECOVERY PROCESS DIAGRAM SITE 4 NWIRP BETHPAGE, NEW YORK	SCALE AS NOTED
		FILE 112G02751FP02
		REV DATE 0 11/26/12
		FIGURE NUMBER FIGURE 5-1C



LEGEND

-  EXISTING MONITORING WELL LOCATION
-  PREVIOUS SOIL BORING LOCATION
-  NOVEMBER 2010 SOIL BORING LOCATION
-  STEAM INJECTION WELL, 6 WELLS
-  FREE PRODUCT RECOVERY WELL, 1 WELL
-  AIR SPARGE WELL, 14 WELLS
-  SOIL CONTAMINATION IN MILLIGRAMS PER KILOGRAM (mg/kg)
TOTAL PETROLEUM HYDROCARBONS (TPH)

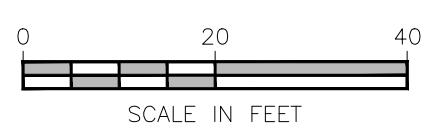

 TETRA TECH	
ALTERNATIVE 4: BIOSPARING WITH STEAM INJECTION AND FREE PRODUCT RECOVERY CONCEPTUAL LAYOUT SITE 4 NWIRP BETHPAGE, NEW YORK	
FILE 112G02751GM05-2	SCALE AS NOTED
FIGURE NUMBER FIGURE 5-2A	REV DATE 0 01/30/13

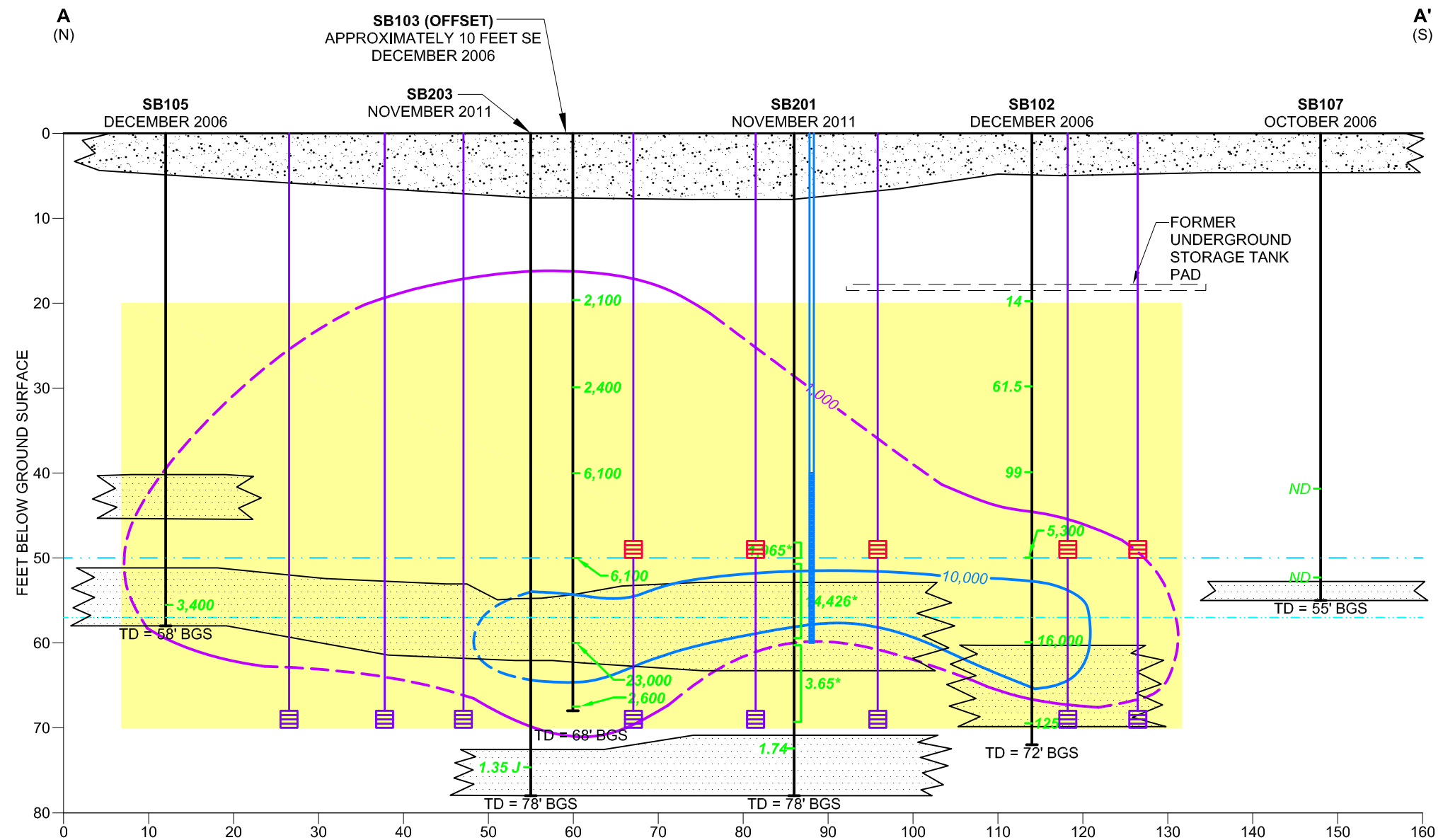

LEGEND

- GRAVEL/ASPHALT
- FINE TO COARSE SAND WITH TRACE CLAY, GRAVEL AND SILT
- SILTY SAND
- 1999 WATER TABLE ~57 FEET BGS
- 2011 WATER TABLE ~50 FEET BGS
- 1,000 TPH (1,000 mg/kg CONTOUR LINE) (DASHED WHERE INFERRED)
- 10,000 TPH (10,000 mg/kg CONTOUR LINE) (DASHED WHERE INFERRED)
- SB102** SOIL BORING
- * AVERAGE TPH CONCENTRATION FROM SB201 AND SB204
- 5,300 TPH RESULT IN MILLIGRAMS PER KILOGRAM (mg/kg)
- TD = 58' BGS TOTAL DEPTH (BGS) BELOW GROUND SURFACE
- ND NOT DETECTED
- TPH TOTAL PETROLEUM HYDROCARBONS
- BIOSPARGE WELL
- STEAM INJECTION WELL
- FREE PRODUCT RECOVERY WELL
- TARGET TREATMENT AREA

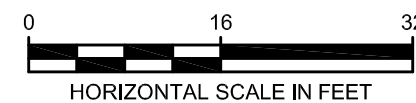

ALTERNATIVE 4: BIOSPARING WITH
STEAM INJECTION AND
FREE PRODUCT RECOVERY
CONCEPTUAL CROSS SECTION VIEW
SITE 4
NWIRP
BETHPAGE, NEW YORK

FILE
112G02751GS02-3

SCALE
AS NOTED

FIGURE NUMBER
FIGURE 5-2B

REV DATE
0 11/28/12

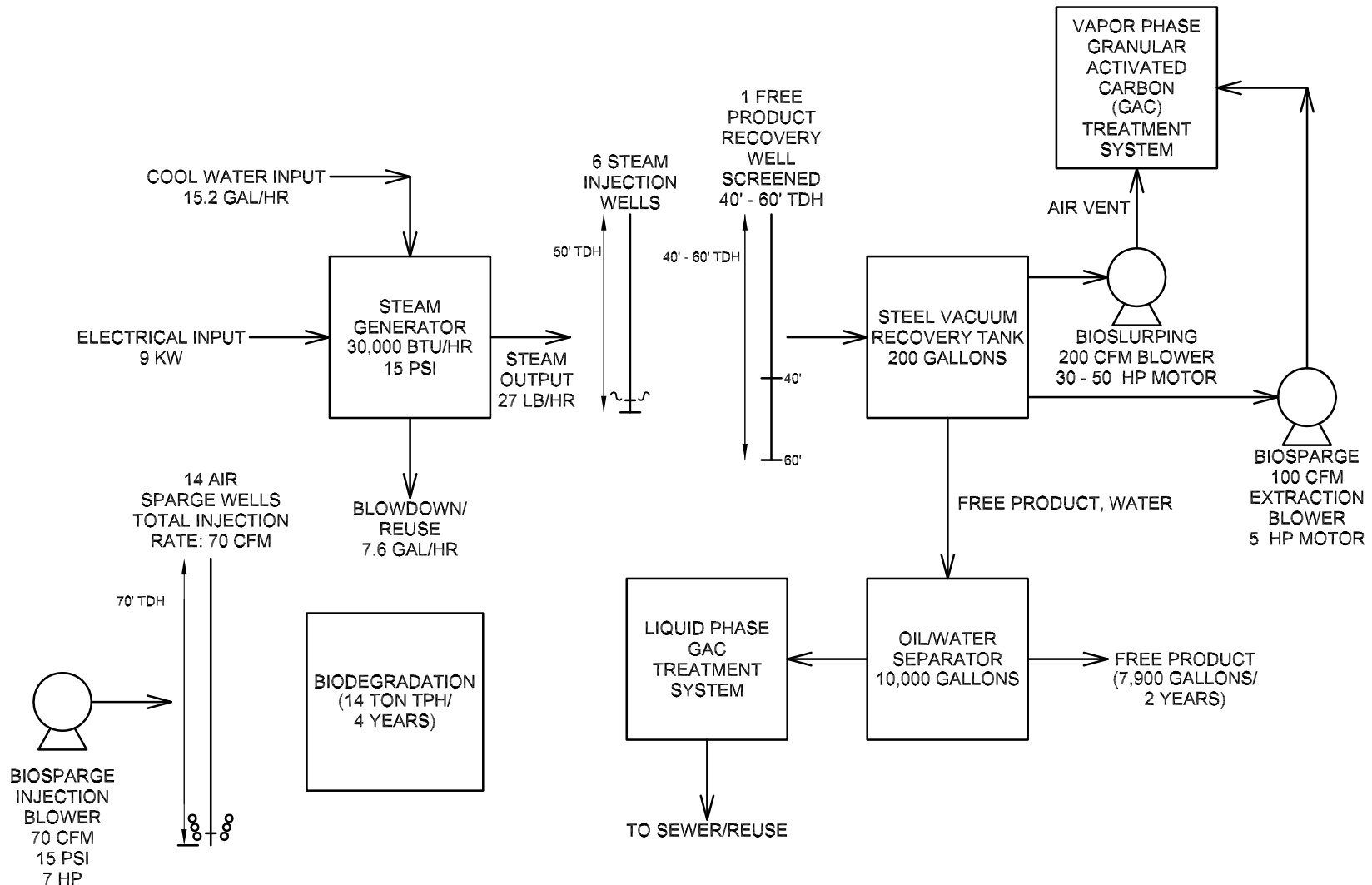

SCHEMATIC: NOT TO SCALE



ALTERNATIVE 4
BIOSPARGING WITH STEAM INJECTION AND
FREE PRODUCT RECOVERY PROCESS DIAGRAM
SITE 4
NWIRP
BETHPAGE, NEW YORK

SCALE AS NOTED	
FILE 112G02751FP02	
REV 0	DATE 11/26/12
FIGURE NUMBER FIGURE 5-2C	

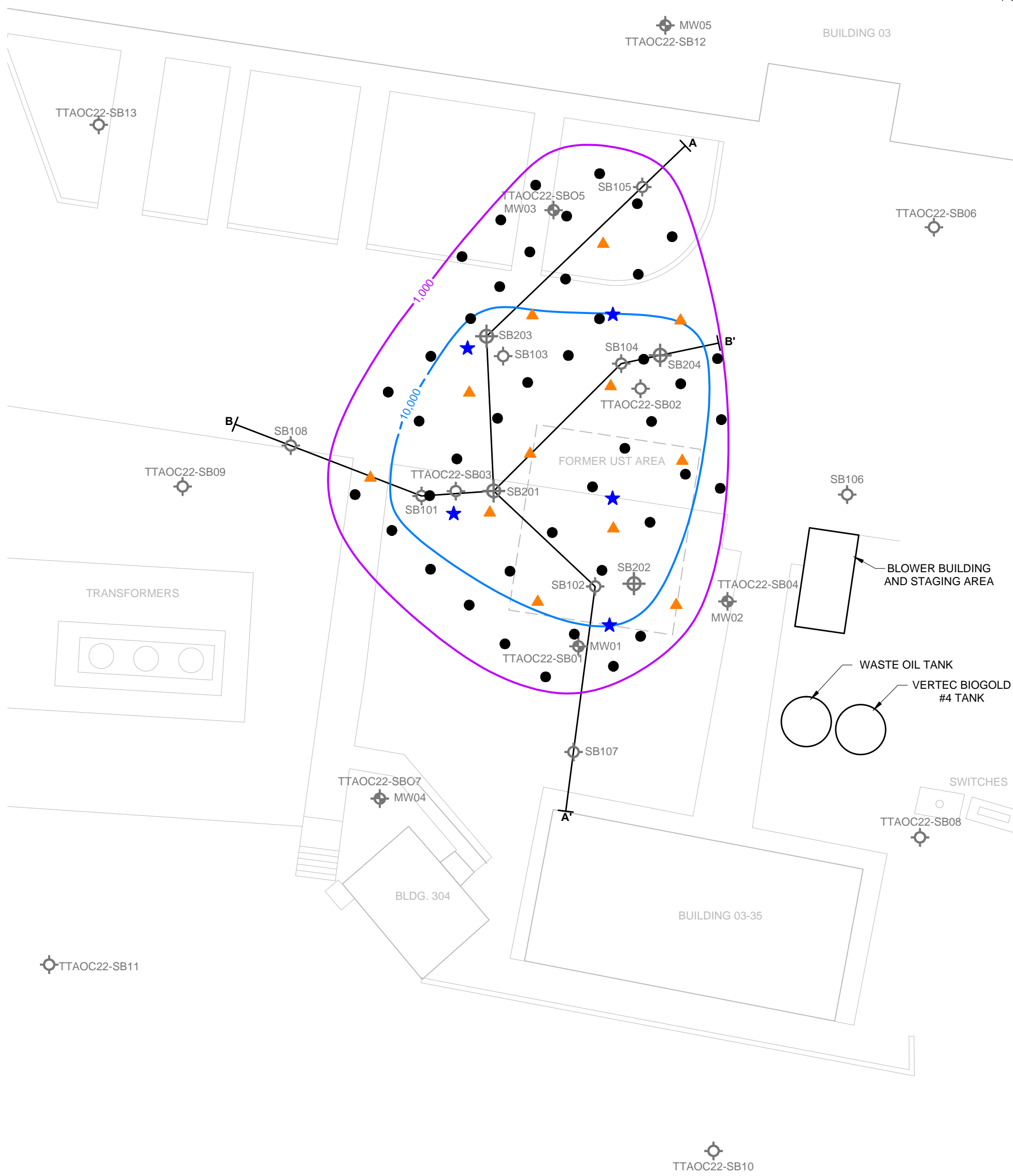

- LEGEND**
- EXISTING MONITORING WELL LOCATION
 - PREVIOUS SOIL BORING LOCATION
 - NOVEMBER 2010 SOIL BORING LOCATION
 - DUAL AIR/SOLVENT INJECTION WELL, 12 WELLS
 - FREE PRODUCT RECOVERY WELL, 5 WELLS
 - SHALLOW SOLVENT INJECTION WELL, 44 WELLS
 - SOIL CONTAMINATION IN MILLIGRAMS PER KILOGRAM (mg/kg)
TOTAL PETROLEUM HYDROCARBONS (TPH)

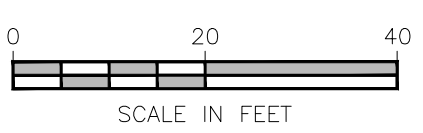

 TETRA TECH	
ALTERNATIVE 5: SOLVENT EXTRACTION AND FREE PRODUCT RECOVERY WITH BIOSPARING CONCEPTUAL LAYOUT BIOSPARING SITE 4 NWIRP BETHPAGE, NEW YORK	
FILE 112G02751GM02-2	SCALE AS NOTED
FIGURE NUMBER FIGURE 5-3A	REV DATE 0 01/30/13

112G02751\FS\DR\112G02751GS02-5.DWG - 11/28/12 MKR

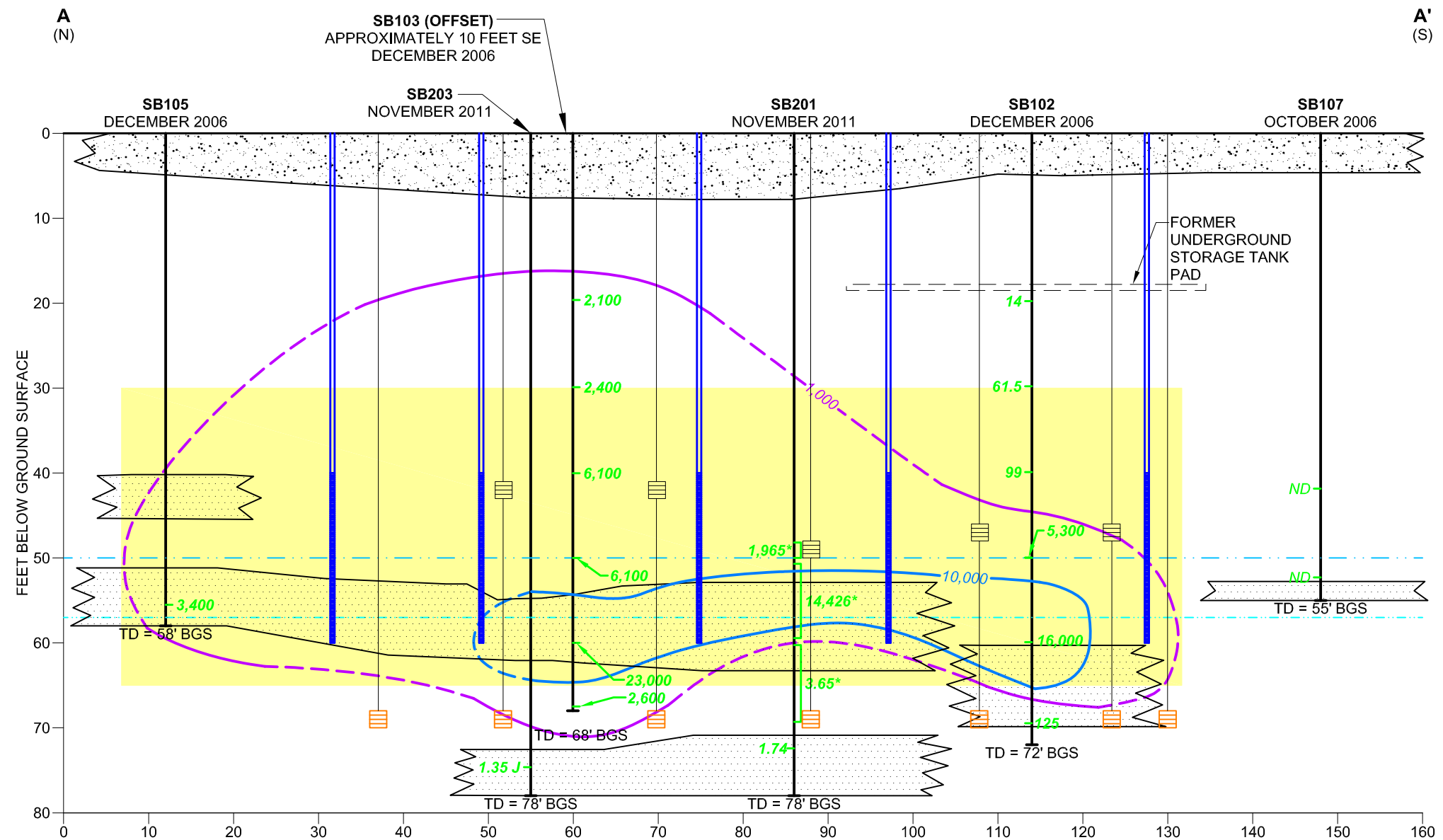

LEGEND

- GRAVEL/ASPHALT
- FINE TO COARSE SAND WITH TRACE CLAY, GRAVEL AND SILT
- SILTY SAND
- 1999 WATER TABLE ~57 FEET BGS
- 2011 WATER TABLE ~50 FEET BGS
- 1,000 TPH (1,000 mg/kg CONTOUR LINE) (DASHED WHERE INFERRED)
- 10,000 TPH (10,000 mg/kg CONTOUR LINE) (DASHED WHERE INFERRED)
- SB102** SOIL BORING
- * AVERAGE TPH CONCENTRATION FROM SB201 AND SB204
- 5,300 TPH RESULT IN MILLIGRAMS PER KILOGRAM (mg/kg)
- TD = 58' BGS TOTAL DEPTH (BGS) BELOW GROUND SURFACE
- ND NOT DETECTED
- TPH TOTAL PETROLEUM HYDROCARBONS
- SOLVENT EXTRACTION WELL
- DUAL AIR/SOLVENT INJECTION WELL
- FREE PRODUCT RECOVERY WELL
- TARGET AREA OF SOLVENT EXTRACTION

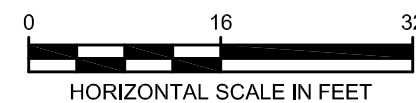

ALTERNATIVE 5:
 SOLVENT EXTRACTION AND FREE
 PRODUCT RECOVERY WITH BIOSPARING
 CONCEPTUAL CROSS SECTION VIEW
 SITE 4
 NWIRP
 BETHPAGE, NEW YORK

FILE 112G02751GS02-5
 FIGURE NUMBER **FIGURE 5-3B**

SCALE AS NOTED
 REV 0 DATE 11/28/12

PHASE 1 - SOLVENT EXTRACTION
PHASE 2 - BIOSPARGING

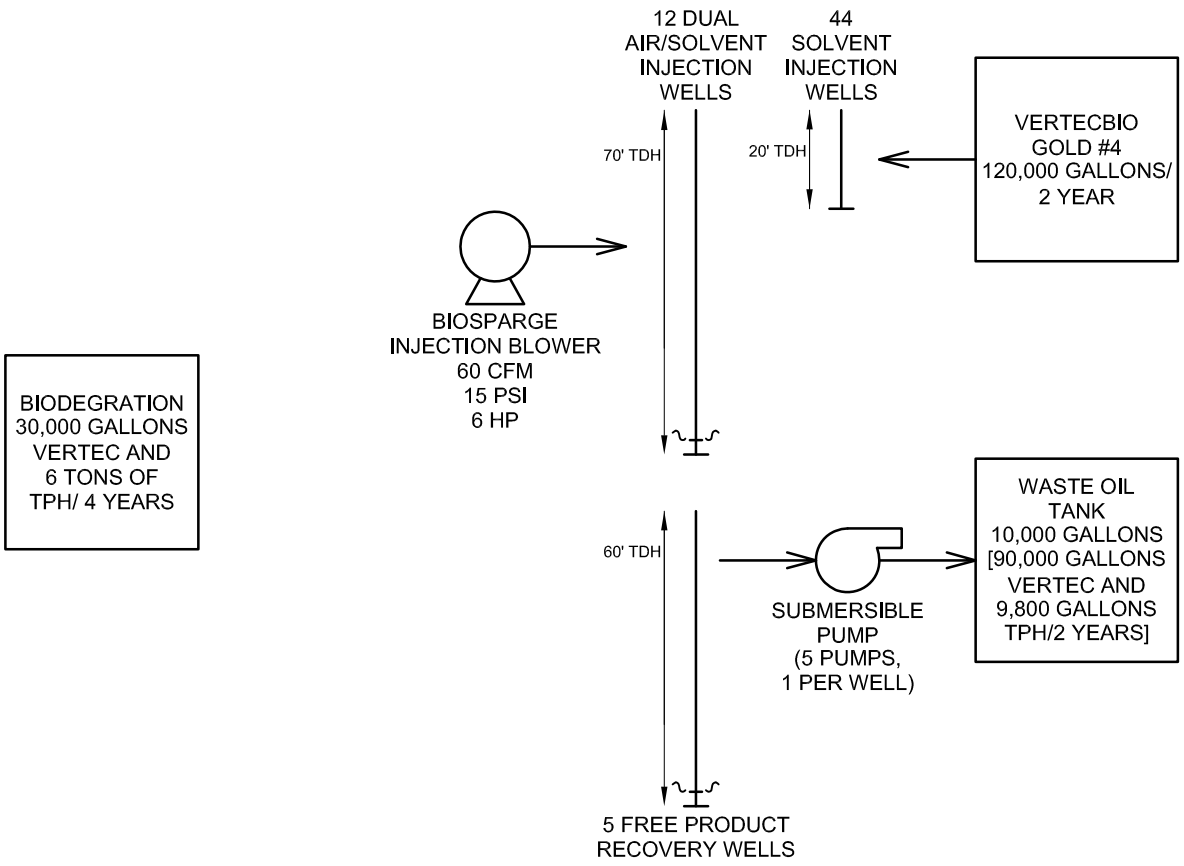

ALTERNATIVE 5
 SOLVENT EXTRACTION AND FREE PRODUCT RECOVERY
 WITH BIOSPARGING PROCESS DIAGRAM
 SITE 4
 NWIRP
 BETHPAGE, NEW YORK

SCALE AS NOTED	
FILE 112G02751FP02	
REV 0	DATE 11/28/12
FIGURE NUMBER FIGURE 5-3C	

SCHEMATIC: NOT TO SCALE

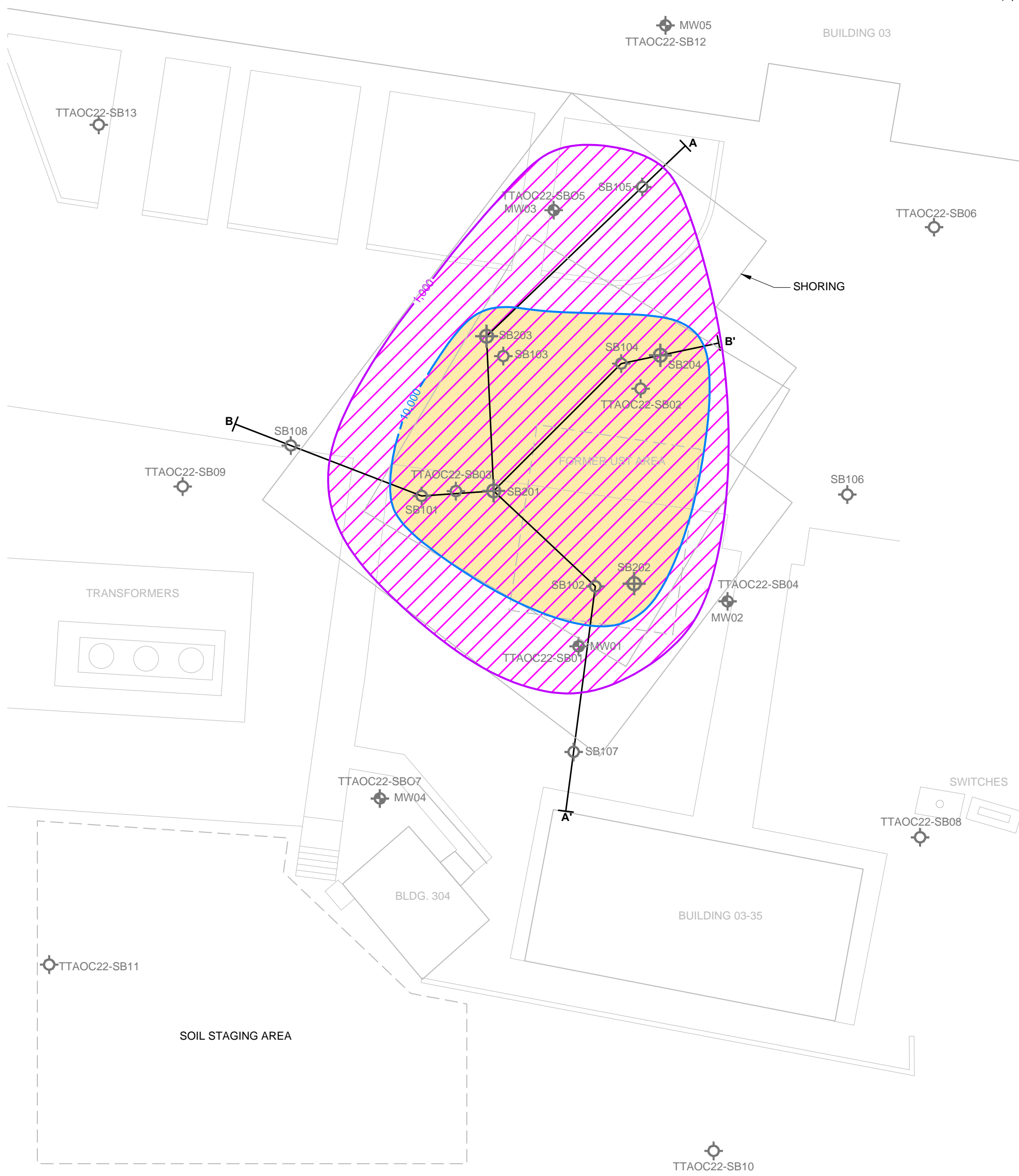

LEGEND

- EXISTING MONITORING WELL LOCATION
- PREVIOUS SOIL BORING LOCATION
- NOVEMBER 2010 SOIL BORING LOCATION
- ALTERNATIVE 6A SOIL EXCAVATION TPH > 10,000 mg/kg
- ALTERNATIVE 6B SOIL EXCAVATION TPH > 1,000 mg/kg
- SOIL CONTAMINATION IN MILLIGRAMS PER KILOGRAM (mg/kg)
TOTAL PETROLEUM HYDROCARBONS (TPH)

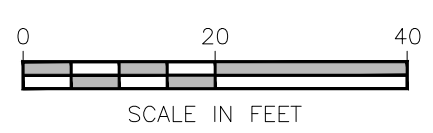

TETRA TECH	
ALTERNATIVES 6A AND 6B: EXCAVATION CONCEPTUAL LAYOUT SITE 4 NWIRP BETHPAGE, NEW YORK	
FILE 112G02751GM02-1	SCALE AS NOTED
FIGURE NUMBER FIGURE 5-4A	REV DATE 0 01/30/13

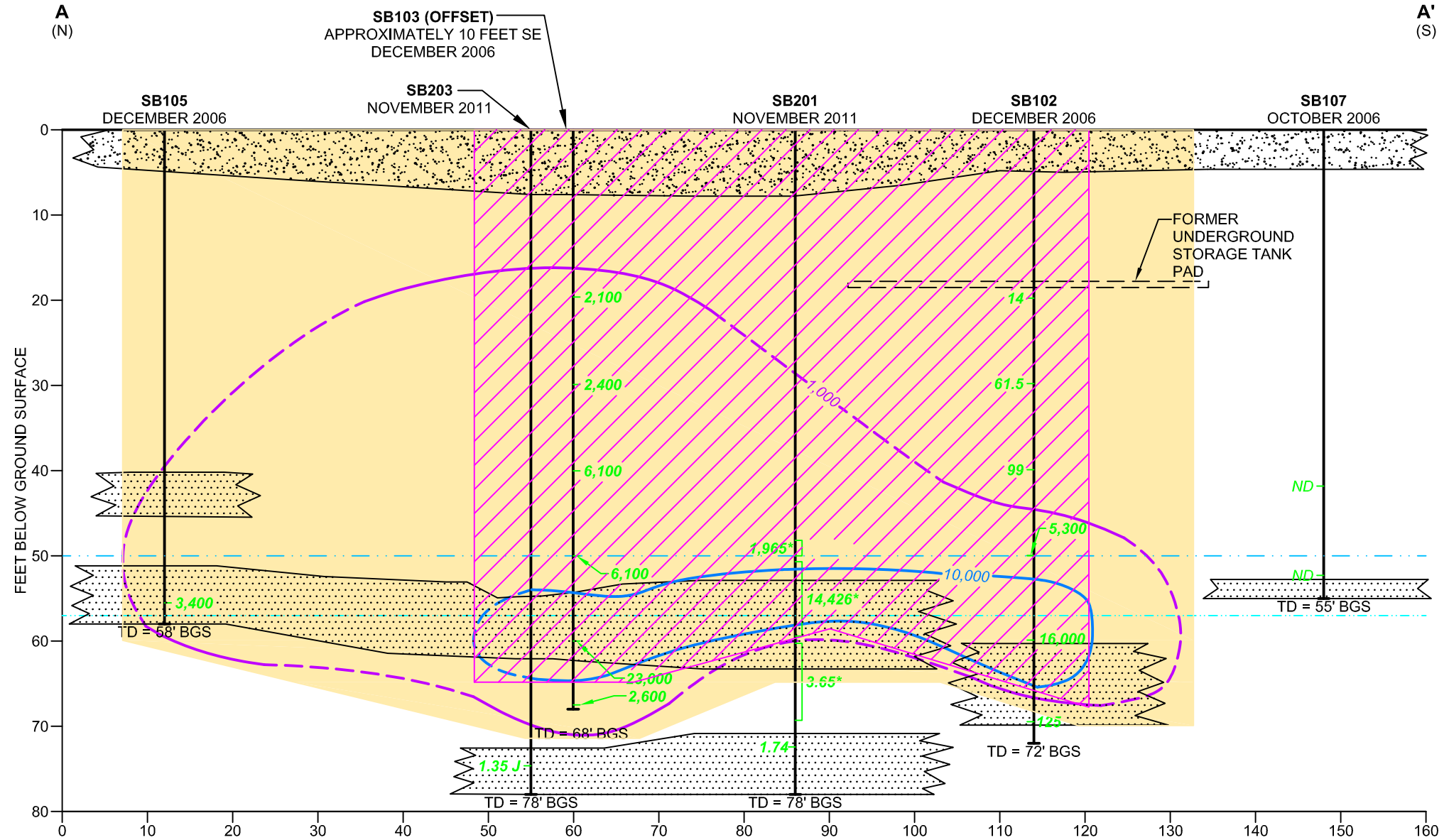

- LEGEND**
- SAND WITH GRAVEL/ASPHALT/CONCRETE
 - FINE TO COARSE SAND WITH TRACE CLAY, GRAVEL AND SILT
 - SILTY SAND
 - CLAYEY SILT
 - CLAYEY SAND
 - 1999 WATER TABLE ~57 FEET BGS
 - 2011 WATER TABLE ~50 FEET BGS
 - TPH (1,000 mg/kg CONTOUR LINE) (DASHED WHERE INFERRED)
 - TPH (10,000 mg/kg CONTOUR LINE) (DASHED WHERE INFERRED)

- SB102** SOIL BORING
- * AVERAGE TPH CONCENTRATION FROM SB201 AND SB204
- 5,300 TPH RESULT IN MILLIGRAMS PER KILOGRAM (mg/kg)
- TD = 58' BGS TOTAL DEPTH (BGS) BELOW GROUND SURFACE
- ND NOT DETECTED
- TPH TOTAL PETROLEUM HYDROCARBONS
- ALTERNATIVE 6A: (TPH > 1,000 mg/kg) EXCAVATION BOUNDARY (WIDTH: 72 FEET, DEPTH: 65 FEET) BACKFILL SOILS
- ALTERNATIVE 6B: (TPH > 10,000 mg/kg) EXCAVATION BOUNDARY (WIDTH: 72 FEET, DEPTH: 65 FEET) BACKFILL SOILS

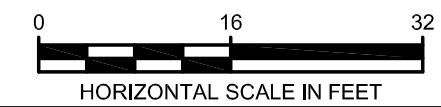

TETRA TECH

ALTERNATIVES 6A AND 6B: EXCAVATION CONCEPTUAL CROSS SECTION VIEW SITE 4 NWIRP BETHPAGE, NEW YORK

FILE 112G02751GS02-6	SCALE AS NOTED
FIGURE NUMBER FIGURE 5-4B	REV DATE 0 11/28/12

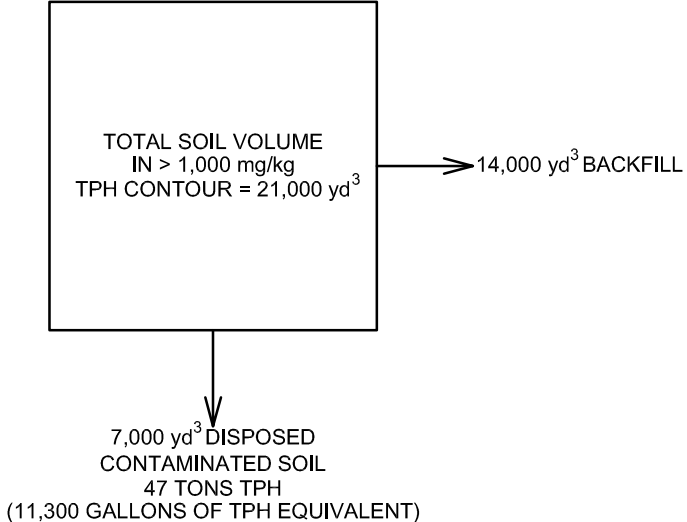

ALTERNATIVE 6A
EXCAVATION PROCESS DIAGRAM
SITE 4
NWIRP
BETHPAGE, NEW YORK

SCALE AS NOTED	
FILE 112G02751FP02	
REV 0	DATE 11/28/12
FIGURE NUMBER FIGURE 5-4C	

SCHEMATIC: NOT TO SCALE

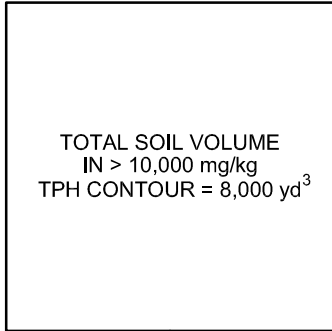

6,600 yd³ BACKFILL

1,400 yd³ DISPOSED
CONTAMINATED SOIL
30 TONS TPH
(7,100 GALLONS OF TPH EQUIVALENT)



ALTERNATIVE 6B
EXCAVATION PROCESS DIAGRAM
SITE 4
NWIRP
BETHPAGE, NEW YORK

SCALE AS NOTED	
FILE 112G02751FP02	
REV 0	DATE 11/28/12
FIGURE NUMBER FIGURE 5-4D	

SCHEMATIC: NOT TO SCALE

APPENDIX A
ANALYTICAL RESULTS FREE PRODUCT SAMPLE

TABLE 4-4

**ANALYTICAL RESULTS FOR FREE PRODUCT SAMPLE
AOC 22 - FORMER UST AREA
NWIRP BETHPAGE, NEW YORK**

Parameter	TTNUS-22-FP-COMP
Volatile Organic Compounds	None detected
Semivolatile Organic Compounds	None detected
PCBs	None detected
Pesticides	None detected
Metals (mg/kg)	
Arsenic	1.6
Barium	41.3
Chromium	25.5
Miscellaneous Parameters	
Chloride (mg/kg)	77.6
Combustion (BTUs)	373
Flashpoint (F)	None detected

APPENDIX B

**2011/2012 SITE 4 BENCHSCALE
TREATABILITY STUDY TEST RESULTS**

**TECHNICAL MEMORANDUM
SITE 4 - BENCH SCALE STUDY
NAVAL WEAPONS INDUSTRIAL RESERVE PLANT (NWIRP)
BETHPAGE, NEW YORK**

1.0 INTRODUCTION

This Technical Memorandum was prepared by Tetra Tech, Inc. (Tetra Tech) for Naval Facilities Engineering Command (NAVFAC) under the Comprehensive Long-term Environmental Action Navy (CLEAN) IV Contract No. N62470-08-D-1001, Contract Task Order (CTO) WE06. This document provides details of a bench scale study that was conducted in 2011 at Site 4 at Naval Weapons Industrial Reserve Plant (NWIRP) Bethpage, New York (Figures 1 and 2). This study evaluated thermal and solvent treatment of total petroleum hydrocarbons (TPH) (No. 6 Fuel Oil)-contaminated soils at the NWIRP Bethpage site. Thermal treatment was conducted to simulate a steam injection and free product recovery option being recommended by New York State Department of Environmental Conservation for this site, while solvent treatment was conducted using diesel and a soybean-based solvent (VertecBio Gold #4 [Vertec]) to consider potential innovative technologies. The soybean-based solvent is a green technology that is an environmentally-friendly approach aimed at desorbing the No.6 fuel oil from the soil to allow recovery of the product (see Attachment A). Following the thermal and solvent treatment testing, aerobic biodegradation (biosparging) was evaluated on the residuals. Biosparging, as a stand-alone technology, was also evaluated. The initial testing was conducted in June 2011. The soil residues from the initial testing were then aerated and additional samples were collected in August 2011 (2 months) and December 2011 (6 months).

2.0 SCOPE AND OBJECTIVES

Site 4 was impacted by a release of No. 6 fuel oil from underground storage tanks between 1940s and 1982. The tanks were removed some time before 1994. Petroleum-contaminated soil and semi-solid petroleum product are present at a depth of approximately 20 to 71 feet below ground surface (bgs). Groundwater is present at approximately 50 to 60 feet bgs. The groundwater also contains trichloroethene and other chlorinated VOCs at concentrations greater than MCLs. The objectives of this bench top study were as follows:

- Evaluate the feasibility of using thermal and solvent-based extraction to allow recovery of the petroleum product above and below the water table, followed by biodegradation of treatment residuals. The goal was to achieve a residual petroleum hydrocarbon concentration of less than 0.1 to 1.0 percent, such that free product is no longer formed.
- Evaluate biodegradation of the soil residues.

Previous soil testing at the site identified petroleum-contaminated soil at a depth of 71 feet bgs, which is approximately 10 to 20 feet below the water table. The presence of this contamination below the water table indicates that some of the petroleum release has migrated below the current depth of the groundwater table (52 to 55 feet bgs). Free product is present at the site, but is generally very viscous and is mostly adsorbed onto site soils. These characteristics make it impractical to remove directly via skimming.

In commercial and residential uses, No. 6 fuel oil is normally heated to 150 Fahrenheit (F) to 250 F to reduce the viscosity to allow it to flow; however its flash point is 150 F, so caution must be used when heating it above 150 F. No. 6 fuel oil is not very water soluble and is readily adsorbed onto soil. Diesel or No. 2 fuel oil is commonly mixed with No. 6 fuel oil to reduce its viscosity and make it more flowable. The diesel or No. 2 fuel oil (specific gravity of approximately 0.88) also reduces the specific gravity of the mixture.

3.0 FIELD METHODS AND OBSERVATIONS

Bench-top studies were conducted to the potential effectiveness of improving the removal of Site 4 product by modifying its physical properties. Technologies evaluated consisted of aeration/agitation, thermal heating (steam injection), solvent extraction, and a combination of these methods. This testing was in part based on preliminary bench scale testing conducted on Site soils in December 2010 that

provided evidence that heat, diesel, and Vertec was able to mobilize the petroleum product to varying degrees.

For these tests, a mixture of heavy stained saturated and unsaturated soils were used. Triplicate samples were collected of the untreated soils to evaluate variability in the mixture (S4-TN3000-01, -02, and -03). The soil was generally black with globules of a tar-like material. The tar-like material is semi-solid and readily adsorbs onto any surface that come in contact with it. The soil has a slight petroleum odor. During drilling, diesel was required to remove the free product from the downhole equipment prior to steam cleaning.

This soil mixture was used to conduct testing described below. During the testing, samples were collected after the initial thermal or solvent extraction treatment steps, and then after 2 months and 6 months of aeration. Samples were analyzed for TPH-DRO and PAHs. TPH-DRO is a direct measure of free product in Site 4 soils and PAHs are used to indicate the present of No. 6 Fuel Oil.

The specific testing conducted is summarized as follows:

- Biosparging
- Thermal heating and thermal heating followed by biosparging
- Solvent extraction using Vertec and solvent extraction followed by biosparging
- Solvent extraction using diesel and solvent extraction followed by biosparging.

The testing also evaluated the effects of these technologies on soils located above and below the water table. The tests were conducted in 6-inch diameter acrylic cylinders, approximately 12 to 18 inches in length. The cylinders were placed in a 7.5 gallon stainless steel container, containing variable amounts of water depending on the test scenario.

3.1 SATURATED AND UNSATURATED SOIL BIOSPARGE SIMULATION TEST (S4-TN3001)

Test S4-TN3001 was conducted to simulate biosparging as a means of reducing the contaminant concentrations at the Site. This test was also conducted as a baseline for comparison with the thermal and solvent extraction pre-treatment tests. In this test, the cylinder was filled with the soil and placed in the container such that the water level was at the midway point of the cylinder (Figure 3-1). Holes were drilled at the midway point of the column to allow the water level to be maintained in the column. Air was introduced into the bottom of the column, and mostly flowed out the top of the cylinder. Some bubbles were noted from the mid-cylinder holes. Water was added to the water bath as need to maintain the level in the container. After 2 and 6 months of aeration, the soils were removed from the columns and placed in a metal pan for observation and sampling.

Field observations were similar after 2 and 6 months of aeration and are summarized as follows.

Parameter	Biosparging (No Pretreatment)
Color	Black
Texture	Slight oily texture
PID Reading (PPM)	5
Odor	Septic and slight petroleum odor

3.2 SATURATED SOIL - HOT WATER RECIRCULATION TEST (S4-TN3002)

Test S4-TN3002 was conducted to develop a basic understanding of how contaminated site soils would respond to thermal treatment and allow modification of the equipment used for subsequent testing. Samples were not collected during this testing. Because of safety concerns with the application of high temperatures and pressure at the bench-scale level, steam injection was not directly evaluated. Instead, steam injection was simulated using a hot water recirculation system and periodic mechanical vibration to agitate the test cylinder.

In this test, the cylinder was mostly filled with soil and submerged in the container so that the water level was near the top of the column (Figure 3-2 and Attachment B – Photos 1 and 2). Water was then circulated from the water bath into the bottom of the cylinder, and allowed to overflow near the top of the

column. The soils were slowly heated to approximately 140F over eight hours. The development of potentially explosive vapors was evaluated during this testing and no concerns were identified.

Free product was noted to flow out of the top of the soil column was manually skimmed from the surface. Because the material was a frothy oil-water mix, it was not feasible to accurately record the volume of product being removed. At the end of the test, the column was allowed to cool overnight and then the contents were visually inspected. Samples were not collected for analytical testing.

During the testing, as hot water migrated upward through the cylinder, and the viscosity of product appear to decrease. The soils were initially dark stained with angular, semi-solid black chunks (tar) present. During the heating, the chunks became small semi-round globules of product and some of the product floated to the surface of the hot water. However, the floating product formed mats and did not readily drain from the cylinder through the holes. Over time, the recirculated water became discolored with silt and dissolved and/or fine droplets of product.

Visually, this test appeared to be somewhat effective at mobilizing the product from Site soils, and transporting the product upward to the water surface. However, the soils remained heavily stained, and a portion of the product appeared to partition to and then remain with the water.

3.3 UNSATURATED SOIL SOLVENT EXTRACTION TESTS (S4-TN3003A, -TN3003B, AND -TN3003C)

The S4-TN3003 tests were conducted to simulate solvent injection into the unsaturated soil (above the water table) to dissolve the No. 6 Fuel Oil into a lower viscosity fluid, allow the fluid to flow to the water table, and then recover the mixture with skimmer pumps. Diesel and Vertec were evaluated as solvents and hot water was evaluated as a control.

In this test, three cylinders were partially filled with soil (Figure 3-3, Attachment B and Photo 3). The bottom of the cylinder was capped with a diffuser plate and end cap. The tops of the cylinders were open, with space to allow the solvent to be uniformly added to the soil. Diesel was added to one cylinder (S4-TN3003A), Vertec was added to the second cylinder (S4-TN3003B), and heated water (approximately 160 to 180 F) was added to the third cylinder (S4-TN3003C). For each test, 3 gallons (approximately 3 cylinder volumes) of liquid were added to the cylinder at approximately 240 milliliters per minute.

The solvents and water were added to the top of the cylinder, allowed to percolate down through the soil, and was then collected underneath the column. The columns were then allowed to drain for a minimum of 2 hours or until fluid was no longer draining from the soil. After draining, a sample was collected from each cylinder and the remaining soil from each cylinder was set aside for use in the biosparging Tests S4-TN3005A, -3005B, and -3005C.

During the testing, diesel and Vertec yielded very similar visual results (Attachment B – Photos 1 to 5). After treatment, the soils were visually less stained and the solvent exiting the bottom of the cylinder was heavily stained brown with the product.

The test using hot water had a very different result. The hot water appeared to mobilize the product, but did not to the extent observed with the solvents. Product desorbed from the soil, and then floated to the top of the water surface. A thick viscous mat of product formed, and adhered to the side of the cylinder as the water level went down (Attachment B – Photo 2). The result was a thick, gummy layer on the soil surface in the cylinder that was difficult to remove.

3.4 SATURATED SOIL SOLVENT EXTRACTION (TEST S4-TN3004A, -TN3004B, AND -TN3004C)

The S4-TN3004 tests were conducted to simulate solvent injection into the saturated soil (below the water table) to dissolve or convert the No. 6 Fuel Oil into a lower viscosity fluid, allow the fluid to flow to the water table, and then recover it with skimmer pumps. Diesel and Vertec were evaluated as solvents and hot water was evaluated as a control.

In this test, three cylinders were partially filled with soil (Figure 3-4 and Attachment B – Photo 2). The cylinder was fitted with a bottom cap containing a diffusion plate for injection of the solvents and water. The injected solvents and water were allowed to overflow into the container. Diesel was added to one cylinder (S4-TN3004A), Vertec was added to the second cylinder (S4-TN3004B), and heated water (approximately 140F) was added to the third cylinder (S4-TN3004C). For each test, 3 gallons

(approximately 3 cylinder volumes) of liquid were added to the cylinder at approximately 100 milliliters per minute. The temperatures of the soil column and solvent were recorded.

After the injection of solvent, unheated water was flushed through the cylinder until the liquid exiting the top was clear. All residual liquid was removed from the top of the cylinder, and the cylinder was removed, inverted and allowed to drain for a minimum of two hours or until fluid was no longer draining from the soil. After draining, a sample was collected from each cylinder and the remaining soil from each cylinder will be set aside for use in the biosparging Tests S4-TN3005A, -3005B, and -3005C.

The observations made with the 3004 tests were similar to those for the 3003 tests. The diesel and Vertec solvents desorbed the product from the soil in the column and transported it along with the solvent. The result of the solvent extraction was a strongly discolored liquid and a visibly clearer soil.

When the test was performed using hot water, product was desorbed from the soil in the column, but did not move with the liquid in solution. Instead, the product floated to the surface of the water, and formed a thick sticky mat.

3.5 BIOSPARGE SIMULATION OF SOLVENT TREATED SOILS (TEST S4-TN3005A, -TN3005B, AND -TN3005C)

The soil residues from tests S4-TN3003 and -TN3004 were combined in cylinders, and matched by type of pretreatment used diesel (S4-TN-3005A), Vertec (S4-TN-3005B) and hot water (S4-TN-3005C). Untreated soil (5 percent) was mixed with each of the soils to provide natural microbes. These columns were then placed in a water bath, similar to test S4-TN3001 (Figure 3-1) and aerated. After 2 and 6 months of aeration, the soils were removed from the columns, drained, and placed in a metal pan for observation and sampling.

Field observations during aeration stage are summarized as follows.

Parameter	Biosparging with Diesel Pretreatment (TN-3005A)	Biosparging with Vertec Pretreatment (TN-3005B)	Biosparging with Hot Water Pretreatment (TN-3005)
Color	Soil is greyish brown, top of column is lighter in color than bottom of column	Soil is a uniform greyish brown, consistent with site soils.	Soil is black
Soil Texture	Slight evidence of oily residue at 2 months, no evidence of oily residue at 6 months	Oily at both 2 and 6 months	Slightly oily texture at 2 and 6 months
PID Reading	50 PPM at 2 months, no reading at 6 months	5 PPM at 2 months, no reading at 6 months	8 PPM at 2 months, no reading at 6 months
Odor	Slight petroleum odor	None	Slight petroleum odor
Other notes	Thin layer of thin product present at 2 months (removed prior to sample), no free product observed at 6 months	None	Thin layer of thick product present at 2 months (removed prior to sample), no product observed at 6 months

4.0 ANALYTICAL RESULTS

Individual PAH and sample-specific results for the untreated samples are provided in Table 4-1. These results are the basis for evaluating the effectiveness of the treatment steps. For comparison, the PAHs in Site 4 soils that could result in a threat to groundwater are highlighted in Table 4-1 (based on EPA SSLs). Note that not all of the site-specific COPCs were detected in the treatability testing soil samples. The average and range of concentrations of PAHs and TPH-DRO in untreated samples (TN-3000-01, -02, and -03) are summarized below.

Untreated Soil Sample Results

Parameter	Mean Concentration (mg/Kg)	Range (mg/Kg)
Total PAH	44.3	41.0 to 47.8
TPH-DRO	12,400 (1.24%)	10,600 to 12,700 (1.06 to 1.27%)

4.1 S4-TN3003 AND –TN3004 PRETREATMENT TEST RESULTS

The effectiveness of the diesel, Vertec, and hot water pretreatment in removing PAHs and TPH-DRO from unsaturated and saturated soils are summarized below. Individual PAH and sample specific results for unsaturated and saturated tests are provided in Tables 4-2 and 4-3, respectively.

Unsaturated Soil Solvent Extraction Test Results (Table 4-2)

Parameter	Diesel Pretreatment (S4-TN3003A) Percent Change	Vertec Pretreatment (S4-TN003B) Percent Change	Hot Water Pretreatment (S4-TN3003C) Percent Change
Total PAH	(+) 59	(-) 83	(+) 16
TPH-DRO	(+) 76	(+) 29	(-) 7

(-) indicates a reduction, (+) indicates an increase

Saturated Soil Solvent Extraction Test Results (Table 4-3)

Parameter	Diesel Pretreatment (TN-3004A) Percent Change	Vertec Pretreatment (TN-3004B) Percent Change	Hot Water Pretreatment (TN-3004C) Percent Change
Total PAH	(+) 66	(-) 54	(+) 8
TPH-DRO	(+) 139	(+) 310	(-) 12

(-) indicates a reduction, (+) indicates an increase

Evaluation of the diesel pretreatment step data (S4-TN3003A and –TN3004A) indicates that the PAH and TPH-DRO concentrations increased in both the saturated and unsaturated soil tests. This results conflicts with visual observations that indicated removal of the free product. The increase in PAH and TPH-DRO concentrations likely results from residual, non-freely draining, diesel in the soils. The diesel would be measured TPH-DRO and the PAHs are likely from the diesel used in the testing.

Evaluation of the Vertec pretreatment step data (S4-TN3003B and –TN3004B) indicates that there was a significant reduction in PAHs in the soil in both the saturated and unsaturated soils, indicating that the Vertec was effective in dissolving and removing the No. 6 fuel oil. This data is consistent with the visual observations during the testing. However, a portion of the Vertec appears to remain adsorbed on the soils (not freely draining) and was measured as TPH-DRO.

Evaluation of the hot water pretreatment step data (S4-TN3003C and –TN3004C) indicates that the TPH concentration decreased slightly (6 to 12 percent), but that there was no significant change (slight increase) in the PAH concentrations.

4.2 S4-TN3005 BIOSPARGING TEST RESULTS

The effectiveness of biosparging on the pretreatment test residuals (S4-TN3005A, -TN3005B, and -TN3005C) and biosparging without pretreatment (S4-TN3001) was then evaluated. Individual PAH and TPH-DRO test results are presented in Table 4-4, 4-5, and 4-6, and are summarized below.

Biosparging Without Pretreatment Test Results (S4-TN3001, Table 4-4)

Parameter	Treatment – 2 Months (Percent Change)	Treatment – 6 Months (Percent Change)
Total PAH	(-) 72	(-) 62
TPH-DRO	(-) 63	(-) 71

(-) indicates a reduction, (+) indicates an increase

Percent Change is based on initial untreated composite sample (TN-3000).

These S4-TN3001 test results indicate that biosparging was able to effectively reduce PAHs and TPH-DRO in site soils. Based on field observations, some of the removal may be the result free product being mobilized and forming on the water surface. Post-treatment TPH-DRO concentrations were approximately 0.35 to 0.46 percent.

Biosparging With Diesel Pretreatment Test Results (S4-TN-3005A, Table 4-5)

Parameter	Initial Sample (S4-TN3003A and -TN3004A) – 0 Months (Percent Change)	Treatment – 2 Months (Percent Change)	Treatment – 6 Months (Percent Change)
Total PAH	(+) 26	(-) 57	(-) 52
TPH-DRO	(+) 108	(-) 39	(+) 21

(-) indicates a reduction, (+) indicates an increase

Percent Change is based on initial untreated sample composite (TN-3000).

The S4-TN3005A test results indicate that biosparging coupled with a diesel pretreatment was partially effective in removing free product from the soil. PAHs and TPH-DRO concentrations decreased during the biosparging step, but these reductions were variable and generally only offset the increase in PAHs and TPH-DRO resulting from the diesel pretreatment. Post-treatment TPH-DRO concentrations were approximately 0.76 to 1.5 percent.

Biosparging With Vertec Pretreatment Test Results (S4-TN3005B, Table 4-6)

Parameter	Initial Sample (S4-TN3003B and -TN3004B) – 0 Months (Percent Change)	Treatment – 2 Months (Percent Change)	Treatment – 6 Months (Percent Change)
Total PAH	(-) 68	(-) 79	(-) 77
TPH-DRO	(+) 169	(-) 23	(+) 27

(-) indicates a reduction, (+) indicates an increase

Percent Change is based on initial untreated sample composite (TN-3000).

The S4-TN3005B test results indicate that biosparging coupled with a Vertec pretreatment was effective in removing No. 6 fuel oil from the soil (based on PAH removal). However, the biosparging step appeared to have only reduced the TPH-DRO concentrations to levels consistent with the untreated soil. Post-treatment TPH-DRO concentrations were approximately 0.95 to 1.6 percent. In addition, the samples collected at 2 months and 6 months had a noticeable oily texture. The ability for this residual oil to form a free product is uncertain.

Biosparging With Hot Water Pretreatment Test Results (S4-TN3005C, Table 4-7)

Parameter	Initial Sample (S4-TN3003C and -TN3004C) – 0 Months (Percent Change)	Treatment – 2 Months (Percent Change)	Treatment – 6 Months (Percent Change)
Total PAH	(+) 8	(-) 49	(-) 58
TPH-DRO	(-) 9	(-) 75	(-) 69

(-) indicates a reduction, (+) indicates an increase

Percent Change is based on initial untreated sample composite (TN-3000).

The S4-TN3005C test results indicate that biosparging coupled with a hot water pretreatment was able to effectively reduce PAHs and TPH-DRO in site soils. Post-treatment TPH-DRO concentrations were approximately 0.31 and 0.39 percent. The results obtained from the biosparging with hot water pretreatment were very similar to that obtained with biosparging alone. Based on field observations, some of the removal may be the result free product being mobilized and forming on the water surface.

5.0 CONCLUSIONS

Conclusions developed from the bench-scale testing of No. 6 Fuel Oil contaminated soils at Site 4 are summarized as follows.

1. The petroleum in Site 4 is mostly present as a semi-solid product that is capable of producing very limited floating free product. Based on groundwater sample results, this material has only a minimal measurable impact on site groundwater.

2. Heating the soil to approximately 120 to 140F is capable of mobilizing some of the product, which can then form on the water surface. However, the released product preferentially adsorbs onto other materials, is very viscous, and is difficult to remove. In addition, the heating appears to have resulted in some of the product to partition to the water. Heating of the soils alone coupled with vibration and skimming was able to reduce TPH-DRO concentrations by 7 to 12 percent.
3. Diesel- and Vertec-based extraction both provided visual evidence of removing No. 6 fuel oil from the site soils. The Vertec pretreatment reduced PAH concentrations by approximately 68 percent, whereas the PAH concentrations in the diesel pre-treated samples initially increased by 61 percent. In addition, these solvents resulted in the TPH-DRO concentration in soils to increase by 76 to 310 percent.
4. The use of biosparging was moderately effective in reducing PAHs and TPH-DRO in soil in each of the tests. Biosparging with and without hot water pretreatment provided similar results with PAHs and TPH-DRO concentrations being reduced by approximately 60 percent and 70 percent, respectively. The biosparging released free product to the water surface which would need to be addressed.
5. The use of biosparging was also moderately effective into reducing PAHs and TPH-DRO introduced by the Vertec and diesel pre-treatment steps, but TPH-DRO concentrations in samples after 6 months of biosparging were similar to untreated samples. Since both diesel and Vertec are reported to be biodegradable, enhanced efforts at promoting biodegradation or extended biosparging may have provided improved TPH-DRO removal.

REFERENCES

Tetra Tech NUS, Inc. (TtNUS), 2007. Soil and Groundwater Report in Support of Closed Loop Bioreactor Pilot-Scale Study, for AOC 22, Site 4, Former Underground Storage Tanks, Naval Weapons Industrial Reserve Plant (NWIRP) Bethpage, New York, September.

**TABLE 4-1
UNTREATED SOIL SAMPLES
BENCH SCALE TESTING - SITE 4
NWIRP BETHPAGE, NY**

Parameter	EPA Risk-based SSL for groundwater	S4-TN3000-01		S4-TN3000-02		S4-TN3000-03		Mean	
		Jun-11		Jun-11		Jun-11			
Date Sampled									
Semi-Volatile Organic Compounds (mg/Kg)									
Acenaphthene	4.1	0.61	U	0.61	U	0.61	U	0.61	U
Acenaphthylene	NE	0.55	U	0.54	U	0.54	U	0.54	U
Anthracene	42	0.44	U	0.44	U	0.44	U	0.44	U
Benzo(a)anthracene	0.01	1.00	U	1.00	U	1.00	U	1.00	U
Benzo(a)pyrene	0.0035	0.47	U	0.47	U	0.47	U	0.47	U
Benzo(b)flouranthene	0.035	0.88	U	0.88	U	0.88	U	0.88	U
Benzo(g,h,i)perylene	NE	0.88	U	0.88	U	0.87	U	0.88	U
Benzo(k)flouranthene	0.35	1.00	U	1.00	U	1.00	U	1.00	U
Chrysene	1.1	0.98	U	0.98	U	0.98	U	0.98	U
Dibenz(a,h)anthracene	0.011	0.62	U	0.62	U	0.62	U	0.62	U
Flouranthene	70	0.44	U	0.43	U	0.43	U	0.43	U
Flourene	4	2.90	J	2.80	J	0.41	U*	2.04	
Indeno(1,2,3-cd)pyrene	0.12	0.72	U	0.72	U	0.72	U	0.72	U
1-Methylnaphthalene	0.0051	9.60	J	9.30	J	9.10	J	9.33	
2-Methylnaphthalene	0.14	13.00	J	12.00	J	12.00	J	12.33	
Naphthalene	0.00047	0.75	U	0.75	U	0.74	U	0.75	U
Phenanthrene	NE	13.00	J	12.00	J	11.00	J	12.00	
Pyrene	9.5	9.30	J	8.10	J	8.50	J	8.63	
Sum of Detected PAHs		47.80		44.20		41.01		44.34	
TPH-DRO (mg/Kg)		10,560		13,900		12,700		12,398	

Notes:

EPA SSL's Soil to Groundwater Supporting Table, April 2012
Using ILCR of 1X10⁻⁶, NC HQ = 1, and DAF = 1
mg/Kg - milligrams per kilogram
sample at a level greater than the
instrument detection

U* - Value of 1/2 the MDL was used in the Calculation
Shading indicates those PAHs that are COPCs.
J - estimated value

TABLE 4-2
SOLVENT EXTRACTION TESTING - UNSATURATED SOILS
BENCH SCALE TESTING - SITE 4
NWIRP BETHPAGE, NY

Parameter	Untreated Sample		Diesel Extraction		Vertec Extraction		Hot Water Extraction	
Semi-Volatile Organic Compounds (mg/Kg)	S4-TN-3000-01, -02, -03		S4-TN3003A-01		S4-TN3003B-01		S4-TN3003C-01	
Acenaphthene	0.61	U	0.30	U	0.06	U	0.31	U
Acenaphthylene	0.54	U	0.27	U	0.054	U	0.27	U
Anthracene	0.44	U	0.22	U	0.36	J	1.80	J
Benzo(a)anthracene	1.00	U	0.51	U	0.10	U	1.60	J
Benzo(a)pyrene	0.47	U	0.23	U	0.046	U	0.23	U
Benzo(b)flouranthene	0.88	U	0.35	U	0.07	U	0.35	U
Benzo(g,h,i)perylene	0.88	U	0.44	U	0.086	U	0.44	U
Benzo(k)flouranthene	1.00	U	0.51	U	0.10	U	0.51	U
Chrysene	0.98	U	0.49	U	0.96	U	3.50	J
Dibenz(a,h)anthracene	0.62	U	0.31	U	0.061	U	0.31	U
Flouranthene	0.43	U	0.22	U	0.043	U	0.22	U
Flourene	2.04		2.30	J	0.38	J	2.20	J
Indeno(1,2,3-cd)pyrene	0.72	U	0.36	U	0.071	U	0.36	U
1-Methylnaphthalene	9.33		17.0	J	1.50	J	10.0	J
2-Methylnaphthalene	12.33		29.0	J	1.70	J	12.0	J
Naphthalene	0.75	U	15.0	J	0.73	U	2.00	J
Phenanthrene	12.00		4.20	J	1.80	J	10.00	J
Pyrene	8.63		3.20	J	1.60	J	8.30	J
Sum of PAH Detections	44.34		70.70		7.71		51.40	
Percent Change in PAHs			59%		-83%		16%	
TPH-DRO (mg/Kg)	12,400		21,859		15,998		11,563	
Percent Change in TPH-DRO			76%		29%		-7%	

Notes:

mg/Kg - milligrams per kilogram

J - estimated value

U - Analyte was not detected in the sample at a level greater than the instrument detection. Value indicated is the Method Detection Limit (MDL).

PAH - petroleum aromatic hydrocarbon

TPH-DRO - total petroleum hydrocarbons, diesel range organics

TABLE 4-3
SOLVENT EXTRACTION TESTING - SATURATED SOILS
BENCH SCALE TESTING - SITE 4
NWIRP BETHPAGE, NY

Parameter	Untreated Sample		Diesel Extraction		Vertect Extraction		Hot Water Extraction	
Semi-Volatile Organic Compounds (mg/Kg)	S4-TN-3000-01, -02, -03		S4-TN3004A-01		S4-TN3004B-01		S4-TN3004C-01	
Acenaphthene	0.61	U	0.061	U	0.32	U	1.4	J
Acenaphthylene	0.54	U	0.055	U	0.29	U	0.27	U
Anthracene	0.44	U	0.044	U	0.23	U	2.00	J
Benzo(a)anthracene	1.00	U	0.10	U	0.54	U	1.50	J
Benzo(a)pyrene	0.47	U	0.047	U	0.24	U	0.23	U
Benzo(b)flouranthene	0.71	U	0.071	U	0.37	U	0.35	U
Benzo(g,h,i)perylene	0.88	U	0.088	U	0.46	U	0.44	U
Benzo(k)flouranthene	1.00	U	0.10	U	0.53	U	0.51	U
Chrysene	4.15	U	0.098	U	0.51	U	3.30	J
Dibenz(a,h)anthracene	0.62	U	0.063	U	0.33	U	0.31	U
Flouranthene	0.43	U	0.044	U	0.23	U	0.22	U
Flourene	2.04		3.20	J	1.70	J	2.60	J
Indeno(1,2,3-cd)pyrene	0.72	U	0.072	U	0.38	U	0.36	U
1-Methylnaphthalene	9.33		19.0	J	4.50	J	7.80	J
2-Methylnaphthalene	12.33		31.0	J	5.60	J	10.0	J
Naphthalene	0.75	U	14.0	J	1.40	J	1.90	J
Phenanthrene	12.00		3.80	J	6.90	J	10.0	J
Pyrene	8.63		2.80	J	0.27	U	7.50	J
Sum of PAH Detections	44.34		73.80		20.37		48.00	
Percent Change in PAHs			66%		-54%		8%	
TPH-DRO (mg/kg)	12,400		29,601		50,805		10,898	
Percent Change in TPH-DRO			139%		310%		-12%	

Notes:

mg/Kg - milligrams per kilogram

J - estimated value

U - Analyte was not detected in the sample at a level greater than the instrument detection. Value indicated is the Method Detection Limit (MDL).

PAH - petroleum aromatic hydrocarbon

TPH-DRO - total petroleum hydrocarbons, diesel range organics

TABLE 4-4
BIOSPARGE TEST RESULTS - NO PRETREATMENT
BENCH SCALE TESTING - SITE 4
NWIRP BETHPAGE, NEW YORK

Semi-Volatile Organic Compounds (mg/Kg)	Untreated Soil Sample (Average of S4-TN-3000-01, -02, and -03, see Table 4-1)		Biosparge Test - 2 months, with No Pretreatment, (S4-TN-3001-60DAYs)		Biosparge Test - 6 months, with No Pretreatment (S4-TN-3001-180DAYs)	
	mg/Kg	U	mg/Kg	U	mg/Kg	U
Acenaphthene*	0.61	U	0.31	U	0.05	U
Acenaphthylene	0.54	U	0.27	U	0.05	U
Anthracene*	0.44	U	0.23	U	0.05	U
Benzo(a)anthracene*	1.00	U	0.53	U	1.20	
Benzo(a)pyrene	0.47	U	0.24	U	0.69	
Benzo(b)flouranthene	0.88	U	0.36	U	0.48	
Benzo(g,h,i)perylene	0.88		0.45	U	0.37	
Benzo(k)flouranthene	1.00	U	0.52	U	0.05	U
Chrysene	0.98	U	1.90	J	2.40	J
Dibenz(a,h)anthracene	0.62	U	0.32	U	0.05	U
Flouranthene	0.43	U	0.22	U	0.93	
Flourene	2.04		0.42	U	0.80	
Indeno(1,2,3-cd)pyrene	0.72	U	0.37	U	0.12	
1-Methylnaphthalene	9.33		2.10	J	1.20	J
2-Methylnaphthalene	12.33		0.28	U	0.36	
Naphthalene	0.75	U	0.38	U	0.05	U
Phenanthrene	12.00		2.50	J	3.00	J
Pyrene	8.63		5.10	J	5.40	J
Sum of Detected PAHs	44.34		12.30		16.95	
TPH-DRO (mg/Kg)	12,400		4,562		3,566	

Percent Change in PAHs

-72.26%

-61.77%

Percent Change in TPH-DRO

-63.21%

-71.24%

Notes:

mg/Kg - milligrams per kilogram

J - estimated value

U - Value indicates that the analyte was not detected in the sample. Value is the method detection limit.

PAHs - petroleum aromatic hydrocarbons

TPH-DRO - total petroleum hydrocarbons, diesel range organics

TABLE 4-5
BIOSPARGE TEST RESULTS, WITH DIESEL PRETREATMENT (S4-TN3005A)
BENCH SCALE TESTING - SITE 4
NWIRP BETHPAGE, NEW YORK

Semi-Volatile Organic Compounds (mg/Kg)	Untreated Soil Sample (Average of S4-TN-3000-01, S4-TN-3000-02, S4-TN-3000-03)		Diesel Pretreatment of Unsaturated Soil Pre Biosparge Treatment (S4-TN-3003A)		Diesel Pretreatment of Saturated Soil Pre Biosparge Treatment (S4-TN-3004A)		Calculated Composite Diesel Pretreated Soils Pre Biosparge Treatment (S4-TN-3003A, S4-TN-3004A)		Biosparge - 2 months, from Diesel Pretreatment Composite (S4-TN-3005A-60DAYS)		Biosparge - 6 months, from Diesel Pretreatment Composite (S4-TN-3005A-	
Acenaphthene	0.61	U	0.30	U	0.061	U	0.30	U*	0.17	U	0.05	U
Acenaphthylene	0.54	U	0.27	U	0.055	U	0.27	U*	0.15	U	0.05	U
Anthracene	0.44	U	0.22	U	0.044	U	0.22	U*	0.12	U	0.05	U
Benzo(a)anthracene	1.00	U	0.51	U	0.10	U	0.51	U*	0.28	U	0.50	
Benzo(a)pyrene	0.47	U	0.23	U	0.047	U	0.23	U*	0.13	U	0.29	
Benzo(b)flouranthene	0.88	U	0.35	U	0.071	U	0.35	U*	0.19	U	0.17	
Benzo(g,h,i)perylene	0.88		0.44	U	0.088	U	0.44	U*	0.24	U	0.25	
Benzo(k)flouranthene	1.00	U	0.51	U	0.10	U	0.51	U*	0.28	U	0.05	U
Chrysene	0.98	U	0.49	U	0.098	U	0.49	U*	0.27	U	0.91	
Dibenz(a,h)anthracene	0.62	U	0.31	U	0.063	U	0.31	U*	0.17	U	0.061	J
Flouranthene	0.43	U	0.22	U	0.044	U	0.22	U*	0.12	U	0.38	
Flourene	2.04		2.30	J	3.20	J	1.95	J	1.50	J	0.05	U
Indeno(1,2,3-cd)pyrene	0.72	U	0.36	U	0.072	U	0.36	U*	0.20	U	0.081	J
1-Methylnaphthalene	9.33		17.0	J	19.0	J	18.0	J	5.90		6.20	
2-Methylnaphthalene	12.33		29.0	J	31.0	J	30.0	J	8.50		7.00	
Naphthalene	0.75	U	15.0	J	14.0	J	14.5	J	0.20	U	0.05	U
Phenanthrene	12.00		4.20	J	3.80	J	4.10	J	1.70	J	2.90	
Pyrene	8.63		3.20	J	2.80	J	2.95	J	1.90	J	3.00	
Sum of Detected PAHs	44.34		70.70		73.80		71.50		19.50		21.74	
TPH-DRO (mg/Kg)	12,400		21,859		29,601		25,750		7,600		15,057	

Percent Change in PAHs	59.46%	66.45%	61.27%	-56.02%	-50.96%
Percent Change in TPH-DRO	76.28%	138.72%	107.66%	-38.71%	21.43%

Notes:

mg/Kg - milligrams per kilogram

J - estimated value

U - Value indicates that the analyte was not detected in the sample at a level greater than the instrument detection. Value indicated is the method detection limit.

U* - Value indicated is the higher of the two method detection limits used for the composite sample (average).

PAHs - petroleum aromatic hydrocarbons

TPH-DRO - total petroleum hydrocarbons, diesel range organics

TABLE 4-6
BIOSPARGE TEST RESULTS, WITH VERTEC PRETREATMENT (S4-TN3005B)
BENCH SCALE TESTING - SITE 4
NWIRP BETHPAGE, NEW YORK

Semi-Volatile Organic Compounds (mg/Kg)	Untreated Soil Sample (Average of S4-TN-3000-01, S4-TN-3000-02, S4-TN-3000-03, see Table 4-1)		Vertec Pretreatment of Unsaturated Soil Pre Biosparge Treatment (S4-TN-3003B)		Vertec Pretreatment of Saturated Soil Pre Biosparge Treatment (S4-TN-3004B)		Calculated Composite Vertec Pretreated Soils Pre Biosparge Treatment (S4-TN-3003B, S4-TN-3004B)		Biosparge - 2 months, from Vertec Pretreatment Composite (S4-TN-3005B-60DAYs)		Biosparge - 6 months, from Vertec Pretreatment Composite (S4-TN-3005B-180DAYs)	
Acenaphthene	0.61	U	0.06	U	0.32	U	0.32	U*	0.32	U	0.06	U
Acenaphthylene	0.54	U	0.054	U	0.29	U	0.29	U*	0.28	U	0.06	U
Anthracene	0.44	U	0.36	J	0.23	U	0.30	J*	0.23	U	0.43	
Benzo(a)anthracene	1.00	U	0.10	U	0.54	U	0.54	U*	0.54	U	0.46	
Benzo(a)pyrene	0.47	U	0.046	U	0.24	U	0.24	U*	0.24	U	0.26	
Benzo(b)flouranthene	0.88	U	0.07	U	0.37	U	0.37	U*	0.37	U	0.16	
Benzo(g,h,i)perylene	0.88		0.086	U	0.46	U	0.46	U*	0.46	U	0.21	
Benzo(k)flouranthene	1.00	U	0.10	U	0.53	U	0.53	U*	0.53	U	0.06	U
Chrysene	0.98	U	0.096	U	0.51	U	0.51	U*	0.51	U	0.87	
Dibenz(a,h)anthracene	0.62	U	0.061	U	0.33	U	0.33	U*	0.32	U	0.06	U
Flouranthene	0.43	U	0.043	U	0.23	U	0.23	U*	0.23	U	0.06	U
Flourene	2.04		0.38	J	1.70	J	1.04	J	0.43	U	0.66	
Indeno(1,2,3-cd)pyrene	0.72	U	0.071	U	0.38	U	0.38	U*	0.37	U	0.082	J
1-Methylnaphthalene	9.33		1.50	J	4.50	J	3.00	J	1.80	J	1.20	
2-Methylnaphthalene	12.33		1.70	J	5.60	J	3.65	J	1.80	J	1.30	
Naphthalene	0.75	U	0.73	U	1.40	J	0.88	J*	0.39	U	0.15	
Phenanthrene	12.00		1.80	J	6.90	J	4.35	J	2.80	J	2.30	
Pyrene	8.63		1.60	J	0.27	U	0.94	J	2.90	J	2.20	
Sum of Detected PAHs	44.34		7.34		20.10		14.15		9.30		10.28	
TPH-DRO (mg/Kg)	12,400		15,998		50,805		33,400		9,543		15,773	

Percent Change in PAHs	-83.44%	-54.67%	-68.08%	-79.02%	-76.81%
Percent Change in TPH-DRO	29.02%	309.72%	169.35%	-23.04%	27.20%

Notes:

mg/Kg - milligrams per kilogram

J - estimated value

U - Value indicates that the analyte was not detected in the sample at a level greater than the instrument detection. Value indicated is the method detection limit.

U* - Value indicated is the higher of the two method detection limits used for the composite sample (average).

J* - Value of 1/2 of the method detection limit was used in the calculation of the composite sample.

PAHs - petroleum aromatic hydrocarbons

TPH-DRO - total petroleum hydrocarbons, diesel range organics

**TABLE 4-7
BIOSPARGE TEST RESULTS, WITH HOT WATER PRETREATMENT (S4-TN3005C)
BENCH SCALE TESTING - SITE 4
NWIRP BETHPAGE, NEW YORK**

Semi-Volatile Organic Compounds (mg/Kg)	Untreated Soil Sample (Average of S4-TN-3000-01, -02, and -03, see Table 4-1)		Hot Water Recirculation Test with Unsaturated Soil Residual - Pre Biosparge Treatment (S4-TN-3003C)		Hot Water Recirculation Test with Saturated Soil Residual - Pre Biosparge Treatment (S4-TN-3004C)		Calculated Residual Composite from Hot Water Pretreatment (S4-TN-3003C and -3004C)		Biosparge Test - 2 months, with Hot Water Pretreatment Composite (S4-TN-3005C-60DAYs)		Biosparge Test - 6 months, with Hot Water Pretreatment Composite (S4-TN-3005C-180DAYs)	
Acenaphthene*	0.61	U	0.31	U	1.40	J	0.86	J	0.32	U	0.70	
Anthracene*	0.44	U	1.80	J	2.00	J	1.90	J	0.23	U	0.84	
Benzo(a)anthracene*	1.00	U	1.60	J	1.50	J	1.55	J	0.55	U	1.00	
Benzo(a)pyrene	0.47	U	0.23	U	0.23	U	0.23	U	0.25	U	0.66	
Benzo(b)flouranthene	0.88	U	0.35	U	0.35	U	0.35	U	0.37	U	0.37	
Benzo(g,h,i)perylene	0.88		0.44	U	0.44	U	0.44	U	0.46	U	0.51	
Benzo(k)flouranthene	1.00	U	0.51	U	0.51	U	0.51	U	0.54	U	0.05	U
Chrysene	0.98	U	3.50	J	3.30	J	3.50	J	1.90	J	2.00	
Dibenz(a,h)anthracene	0.62	U	0.31	U	0.31	U	0.31	U	0.33	U	0.13	
Flouranthene	0.43	U	0.22	U	0.22	U	0.22	U	0.23	U	0.81	
Flourene	2.04		2.20	J	2.60	J	2.40	J	1.80	J	1.10	
Indeno(1,2,3-cd)pyrene	0.72	U	0.36	U	0.36	U	0.36	U	0.38	U	0.15	
1-Methylnaphthalene	9.33		10.0	J	7.80	J	8.90	J	3.50	J	1.10	
2-Methylnaphthalene	12.33		12.0	J	10.0	J	11.0	J	3.80	J	0.90	
Naphthalene	0.75	U	2.00	J	1.90	J	1.95	J	0.39	U	0.05	U
Phenanthrene	12.00		10.0	J	10.0	J	10.0	J	5.30	J	3.50	
Pyrene	8.63		8.30	J	7.50	J	7.90	J	6.50	J	4.70	
Sum of Detected PAHs	44.34		51.40		48.00		49.70		22.80		18.47	
TPH-DRO (mg/Kg)	12,400		11,563		10,898		11,231		3,128		3,901	

Percent Change in PAHs	15.93%	8.26%	12.10%	-48.58%	-58.34%
Percent Change in TPH-DRO	-6.75%	-12.11%	-9.43%	-74.77%	-68.54%

Notes:

mg/Kg - milligrams per kilogram

J - estimated value

U - Value indicates that the analyte was not detected in the sample at a level greater than the instrument detection. Value indicated is the method detection limit.

PAHs - petroleum aromatic hydrocarbons

TPH-DRO - total petroleum hydrocarbons, diesel range organics

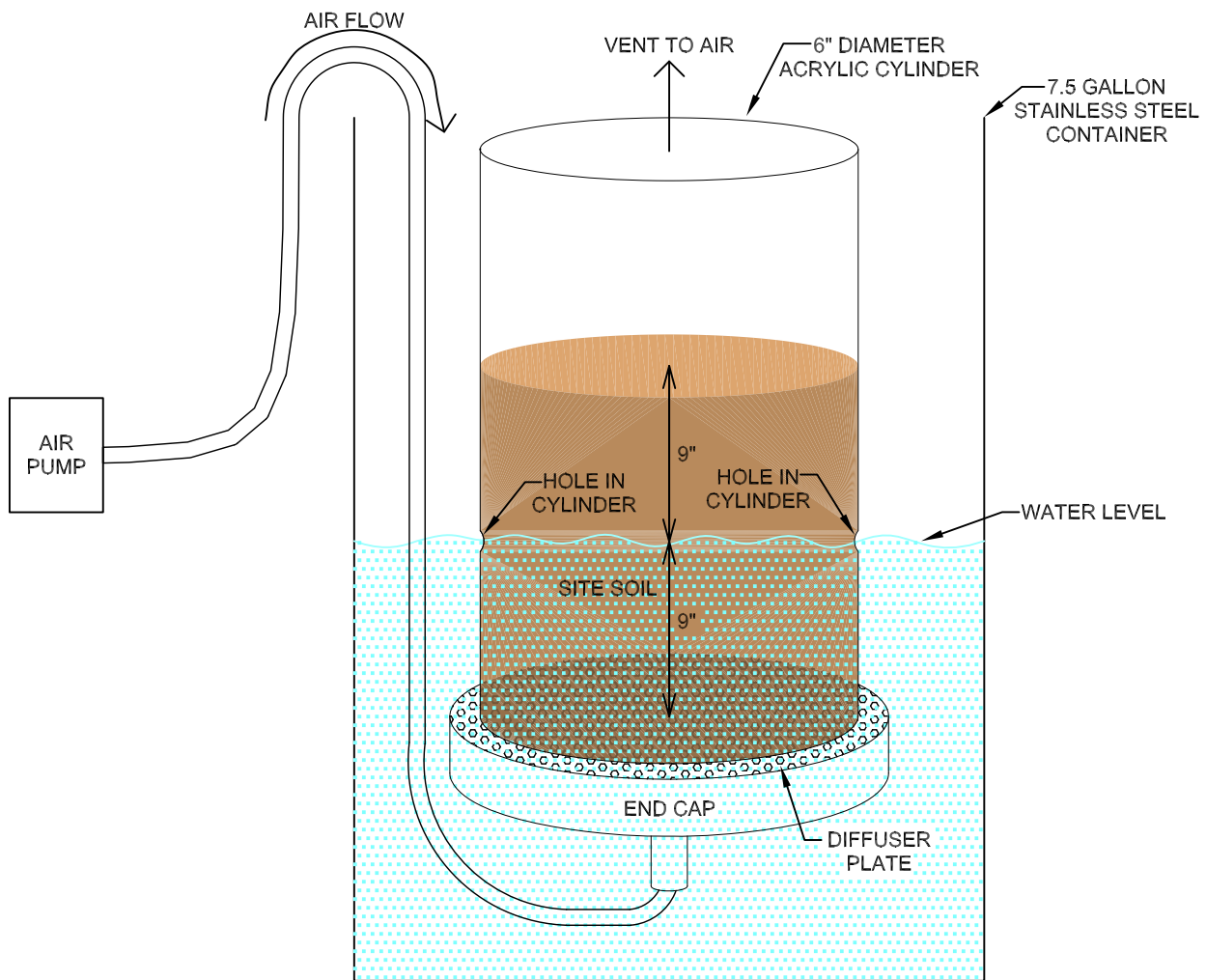

TETRA TECHNUS, INC.

BIOSPARGE TESTS TN3001, TN3005A,
 TN3005B, AND TN3005C
 SITE 4 – BENCH SCALE STUDY
 NWIRP BETHPAGE
 BETHPAGE, NEW YORK

B-17

SCALE AS NOTED	
FILE 112G02019PF01-1	
REV 0	DATE 06/13/11
FIGURE 3-NUMBER FIGURE 3-1	

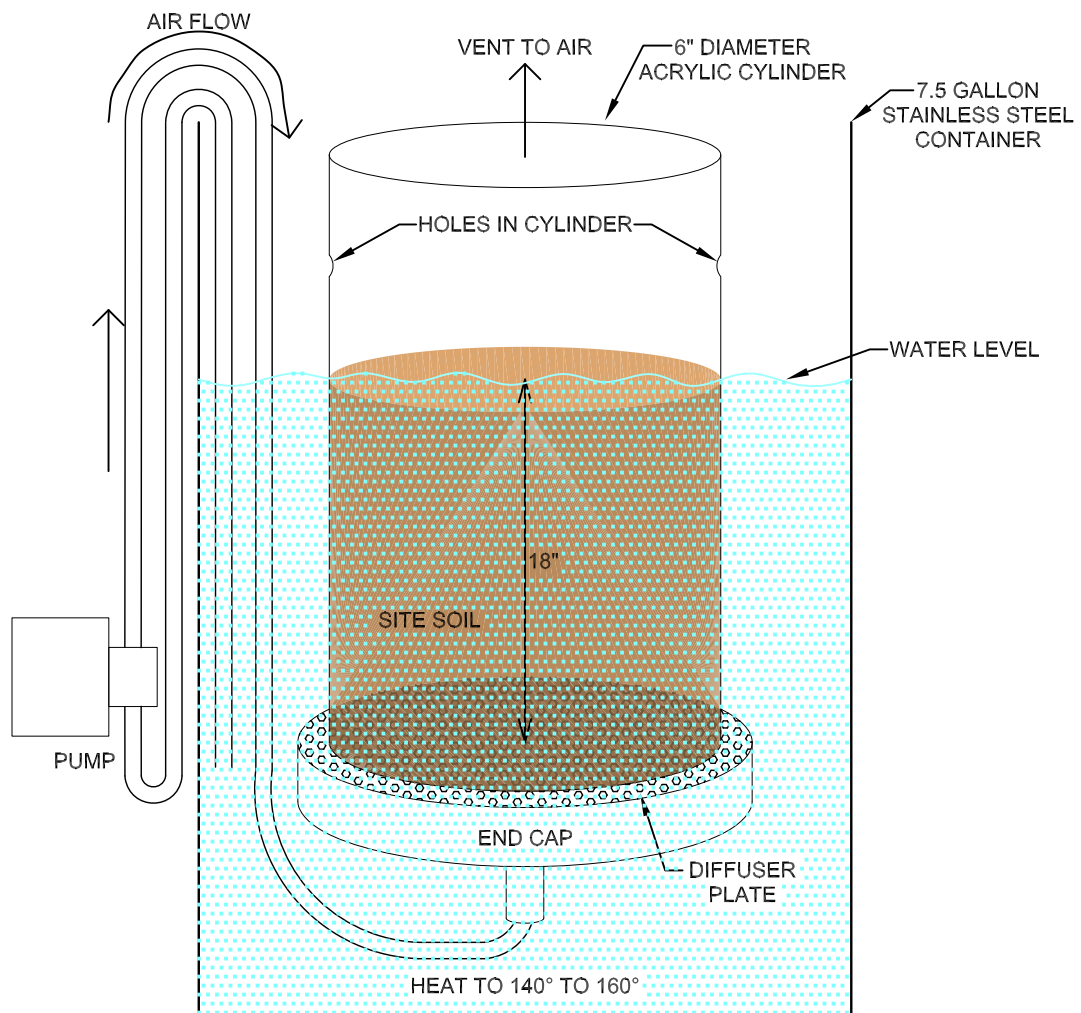

HOT WATER RECIRCULATION TEST TN3002
 SITE 4 – BENCH SCALE STUDY
 NWIRP BETHPAGE
 BETHPAGE, NEW YORK

SCALE AS NOTED	
FILE 112G02019PF01-2	
REV 0	DATE 06/13/11
FIGURE 3-NUMBER FIGURE 3-2	

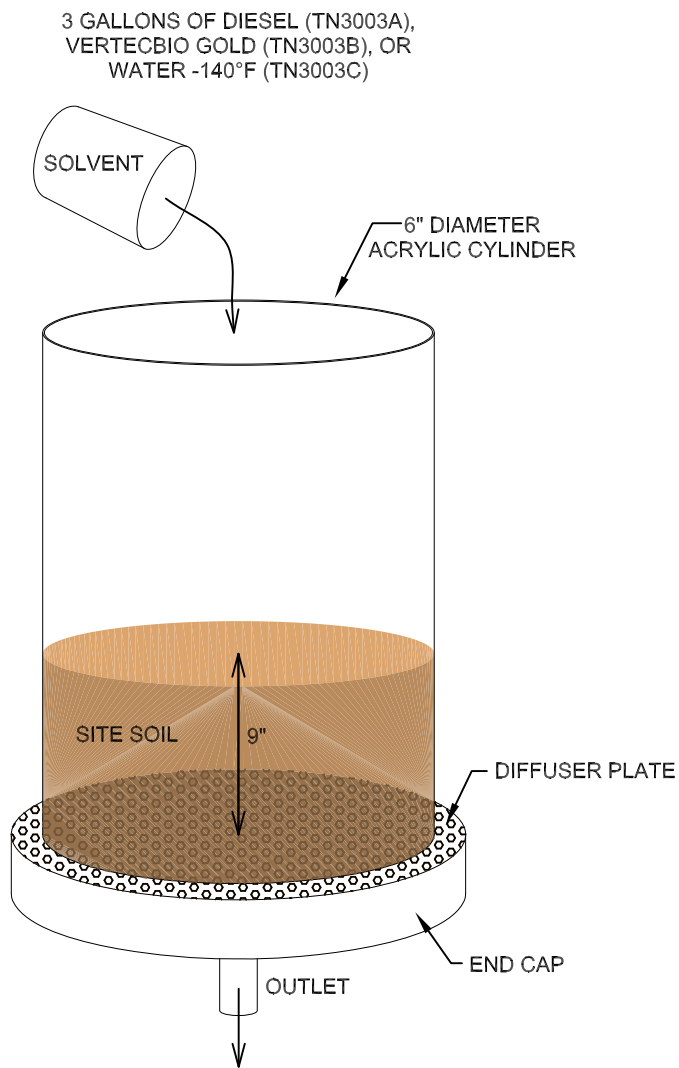

TETRA TECHNUS, INC.

UNSATURATED SOIL SOLVENT EXTRACTION TESTS
 TN3003A, TN 3003B, AND TN3003C
 SITE 4 – BENCH SCALE STUDY
 NWIRP BETHPAGE
 BETHPAGE, NEW YORK

B-19

SCALE
AS NOTED

FILE
112G02019PF01-3

REV DATE
0 06/13/11

FIGURE 3-NUMBER
FIGURE 3-3

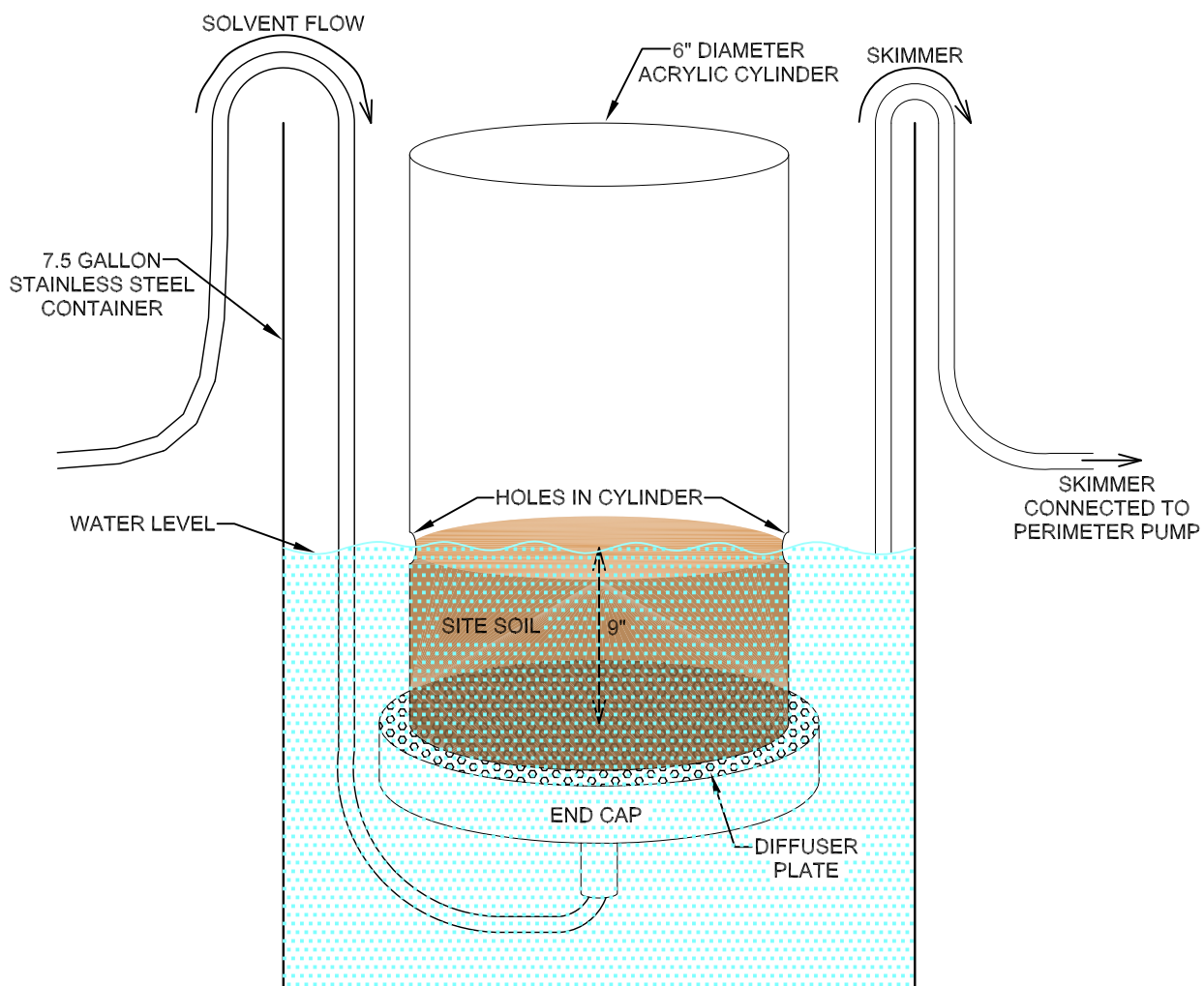

TETRA TECHNUS, INC.

SATURATED SOIL SOLVENT EXTRACTION TESTS
 TN3004A, TN 3004B, AND TN3004C
 SITE 4 – BENCH SCALE STUDY
 NWIRP BETHPAGE
 BETHPAGE, NEW YORK

B-20

SCALE
 AS NOTED

FILE
 112G02019PF01-4

REV	DATE
0	06/13/11

FIGURE 3-NUMBER
 FIGURE 3-4

ATTACHMENT A
VERTECBIO GOLD #4 TECHNICAL DATA SHEET



Methyl Soyate
BioBased Solvent
Soybean Derived

VertecBio Gold EG (economy grade) has similar properties as Gold #4 but is less costly. Gold #4EG has a deep amber color and a slightly stronger vegetable oil odor than Gold #4. This grade of methyl soyate is ideal for formulating mastic and adhesive removers, asphalt release agents and industrial cleaners. This VertecBio Gold #4EG is 100% methyl soyate.

Flash point over 200 F, and less than 5% VOCs

- Low Cost
- Ideal for Formulating Heavy Duty Cleaners, Asphalt Release Agents
- Low VOC
- Very Low Vapor Pressure
- 100% Biodegradable
- Excellent Degreaser
- Flash Point Above 200° F
- Safe, Non-Toxic, Non-Carcinogenic
- Sustainable Chemistry---Small Carbon Footprint
- 93% Biobased Content, Made from Renewable Resources
- EPA Approved SNAP Solvent---No Ozone Depleting Chemicals
- No HAP's---No Hazardous Air Pollutants
- No Global Warming Compounds
- EPA Approved SNAP Solvent
- Non SARA 313 Reportable
- Non-Hazardous Under RCRA



Recognized as Environmentally

Preferable Chemistry

TECHNICAL DATA

Flash Point...>200 F ASTM D93 closed cup
Vapor Pressure.....<1 mmHg @ 68 F
pH of Water Dispersion.....4.3
Specific Gravity.....0.88
Evaporation Rate.....<0.1
Vapor Density.....>4
Boiling Point.....> 600 F
CAS No:67784-80-9

01/21/10

Vertec BioSolvents Inc. 1441 Branding Lane, Suite 100 Downers Grove, IL 60515 USA
☎ 630.960.0600 • 630.960.0660 (fax) • www.vertecbiosolvents.com

ATTACHMENT B
PHOTOLOG

Photo 1 - Side view of column of unsaturated soil after hot water was added in Test TN-3003.



Photo 2 - View of film of product that formed on top of the hot water in Test TN-3003.



B-1

B-27

Photo 3 - Addition of diesel to unsaturated soil in Test TN-3003



Photo 4 - Side view of column of unsaturated soil after Vertec was added in Test TN-3003.



Photo 5 - Side view of column of unsaturated soil after diesel was added in Test TN-3003.



Photo 6 - View of product seeping out of side holes in the cylinder in Test TN-3004.



ATTACHMENT C
ANALYTICAL RESULTS



TO: D. BRAYACK DATE: OCTOBER 20, 2011

FROM: MICHELLE L. ALLEN COPIES: DV FILE

SUBJECT: ORGANIC DATA VALIDATION – PAH/PCB/DRO
 NAVAL WEAPONS INDUSTRIAL RESERVE PLANT (NWIRP), BETHPAGE
 CTO 066
 SAMPLE DELIVERY GROUP (SDG) C2745

SAMPLES: 9/Soil/PAH/DRO/

SN-TN3000-01	SN-TN3000-02	SN-TN3000-03
SN-TN3003A-01	SN-TN3003B-01	SN-TN3003C-01
SN-TN3004A-01	SN-TN3004B-01	SN-TN3004C-01

3/Soil/PCB/

BP-S1-D	BP-S1-UNTREATED	BP-S1-VTBG-4
---------	-----------------	--------------

Overview

The sample set for NWIRP Bethpage, SDG C2745 consisted of twelve (12) soil environmental samples. Nine (9) soil samples were analyzed for polynuclear aromatic hydrocarbons (PAH) and diesel range organics (DRO). Three (3) environmental soil samples were analyzed for polychlorinated biphenyls (PCB). No field duplicate sample pair was associated with this sample data group (SDG).

The samples were collected by Tetra Tech on June 14, 15, and 16, 2011 and analyzed by Chemtech. All analyses were conducted in accordance with SW 846 Method 8270C, 8082, and 8015B analytical and reporting protocols. The data contained in this SDG was validated with regard to the following parameters:

- * • Data Completeness
- * • Hold Times
- * • GC/MS System Tuning and Performance
- Initial and Continuing Calibrations
- Laboratory Method Blank Results
- Surrogate Spike Recoveries
- Internal Standard Results
- * • Laboratory Control Sample/Laboratory Control Sample Duplicate Results
- * • Compound Identification
- Compound Quantitation
- * • Detection Limits

The symbol (*) indicates that all quality control criteria were met for this parameter. Qualified analytical results are presented in Appendix A, results as reported by the laboratory are presented in Appendix B, Region II data validation forms are presented in Appendix C, and documentation supporting these findings is presented in Appendix D.

PAH

The cooler temperature for the PAH soil samples was recorded at 25°C. This temperature exceeds the

recommended preservation temperature of 6°C. The positive and non-detected results reported for the PAHs in all the samples were qualified as estimated, (J) and (UJ), respectively, due to sample preservation noncompliance.

A calibration standard was not performed for the compound 1-methylnaphthalene. The initial calibration Relative Response Factor (RRF) for 2-methylnaphthalene was used to quantify the results reported for 1-methylnaphthalene. All samples were affected. Only positive results were reported for 1-methylnaphthalene in the affected samples and these positive results were qualified as estimated, (J).

The internal standard areas for naphthalene-d8 and acenaphthene-d10 were below the lower quality control limit in sample SN-TN3004A-01. The 5X dilution of this sample yielded acceptable internal standard areas. The results from the undiluted analysis were used in the data validation, with the exception of 1-methylnaphthalene and 2-methylnaphthalene. The positive and non-detected results reported for the PAH compounds associated with these internal standards are qualified as estimated, (J) and (UJ), respectively.

PCB

The cooler temperature for the PCB soil samples was recorded at 25°C. This temperature exceeds the Region II recommended preservation temperature of >10°C. The positive and non-detected results reported for the PCBs in all the samples were qualified as estimated, (J) and (UJ), respectively, due to sample preservation noncompliance.

The surrogate spike compound, decachlorobiphenyl, had %Rs below the lower quality control limit in samples, BP-S1-D, BP-S1-UNTREATED, and BP-S1-VTBG-4. Decachlorobiphenyl and tetrachloro-m-xylene were diluted out in the diluted analyses of samples BP-S1-D and BP-S1-UNTREATED. The surrogates were acceptable in the diluted analysis of BP-S1-VTBG-4. The non-detected PCB results reported from the undiluted analyses of these samples were qualified as estimated, (UJ). No action was taken for the positive results reported for Aroclor 1242 because these results were taken from the diluted analyses.

DRO

The cooler temperature for the DRO soil samples was recorded at 25°C. This temperature exceeds the recommended preservation temperature of 6°C. The positive results reported for DRO in all the samples were qualified as estimated, (J), due to sample preservation noncompliance.

Additional Comments

The PAH surrogate spike compound, nitrobenzene-d5, had a Percent Recovery (%R) above the upper quality control limit in sample SN-TN3004A-01. No action was taken because only one surrogate was noncompliant.

The DRO surrogate spike compound was not detected in the environmental samples due to the dilutions of these samples.

The samples below were diluted prior to analysis for the following fractions:

<u>Sample</u>	<u>Fraction</u>	<u>Dilution Factor</u>
SN-TN3000-01	PAH	10X
	DRO	100X

SN-TN3000-02	PAH	10X
	DRO	100X
SN-TN3000-03	PAH	10X
	DRO	200X
SN-TN3003A-01	PAH	5X
	DRO	200X
SN-TN3003B-01	DRO	200X
SN-TN3003C-01	PAH	5X
	DRO	100X
SN-TN3004A-01	DRO	500X
SN-TN3004B-01	PAH	5X
	DRO	500X
SN-TN3004C-01	PAH	5X
	DRO	100X

1-Methylnaphthalene and 2-methylnaphthalene exceeded the instrument's linear calibration range in the undiluted analysis of sample, TN-3004A-01. The sample was reanalyzed at a 5X dilution. The results from the dilution for these compounds were used in the data validation.

Aroclor 1242 exceeded the instrument's linear calibration range for samples analyzed for PCBs. The samples were reanalyzed at 5X, 20X, and 5X dilutions, respectively. The results for Aroclor 1242 from the diluted analyses were used in the data validation.

Positive PCB results were reported from GC column RTX-CLPest I.

The Region II Data Validation Standard Operating Procedures (SOPs) for PAH and DRO analyses were not present on the EPA Region II internet site; therefore, EPA Region II worksheets are not included for these fractions in the data validation letter.

Non-detected results are reported to the Limit of Detection (LOD).

EXECUTIVE SUMMARY

Laboratory Performance Issues: A calibration standard was not analyzed for 1-methylnaphthalene.

Other Factors Affecting Data Quality: The sample coolers were received at room temperature. Many samples required dilutions. Surrogate spike compounds were diluted out in the PCB and DRO fractions. Internal standard areas were low in one sample.

TO: D. BRAYACK
SDG: C2745

PAGE: 4

The data for these analyses were reviewed with reference to the SOP #HW-45, Revision 1.0, USEPA Region II Hazardous Waste Support Branch Validating PCB Compounds PCBs by Gas Chromatography SW-846 Method 8082A (October 2006), SW846 8270C, 8082, and 8015B analytical and reporting protocols, and the Department of Defense (DoD) document entitled "Quality Systems Manual (QSM) for Environmental Laboratories" (January 2006).



TetraTech NUS
Michelle L. Allen
Chemist/Data Validator

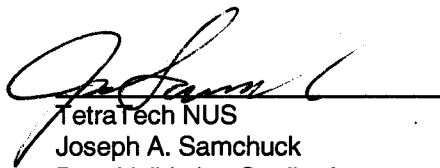

Tetra Tech NUS
Joseph A. Samchuck
Data Validation Quality Assurance Officer

Attachments:

1. Appendix A - Qualified Analytical Results
2. Appendix B - Results as Reported by the Laboratory
3. Appendix C - Region II Data Validation Forms
4. Appendix D - Support Documentation

Appendix A

Qualified Analytical Results

Data Validation Qualifier Codes:

- A = Lab Blank Contamination
- B = Field Blank Contamination
- C = Calibration Noncompliance (e.g. % RSDs, %Ds, ICVs, CCVs, RRFs, etc.)
- C01 = GC/MS Tuning Noncompliance
- D = MS/MSD Recovery Noncompliance
- E = LCS/LCSD Recovery Noncompliance
- F = Lab Duplicate Imprecision
- G = Field Duplicate Imprecision
- H = Holding Time Exceedance
- I = ICP Serial Dilution Noncompliance
- J = GFAA PDS - GFAA MSA's $r < 0.995$ / ICP PDS Recovery Noncompliance
- K = ICP Interference - includes ICS % R Noncompliance
- L = Instrument Calibration Range Exceedance
- M = Sample Preservation Noncompliance
- N = Internal Standard Noncompliance
- N01 = Internal Standard Recovery Noncompliance Dioxins
- N02 = Recovery Standard Noncompliance Dioxins
- N03 = Clean-up Standard Noncompliance Dioxins
- O = Poor Instrument Performance (e.g. base-line drifting)
- P = Uncertainty near detection limit ($< 2 \times$ IDL for inorganics and $< CRQL$ for organics)
- Q = Other problems (can encompass a number of issues; e.g. chromatography, interferences, etc.)
- R = Surrogates Recovery Noncompliance
- S = Pesticide/PCB Resolution
- T = % Breakdown Noncompliance for DDT and Endrin
- U = % Difference between columns/detectors $> 25\%$ for positive results determined via GC/HPLC
- V = Non-linear calibrations; correlation coefficient $r < 0.995$
- W = EMPC result
- X = Signal to noise response drop
- Y = Percent solids $< 30\%$
- Z = Uncertainty at 2 sigma deviation is greater than sample activity

PROJ_NO: 02019	NSAMPLE	SN-TN3000-01		SN-TN3000-02		SN-TN3000-03		SN-TN3003A-01	
		LAB_ID	C2745-01	C2745-02	C2745-03	C2745-04	SAMP_DATE	6/14/2011	6/15/2011
SDG: C2745	QC_TYPE	NM	NM	NM	NM	UG/KG	UG/KG	UG/KG	UG/KG
FRACTION: PAH	PCT_SOLIDS	92.0	92.0	92.0	92.0	92.0	92.0	92.0	92.0
MEDIA: SOIL	DUP_OF								
PARAMETER	RESULT	VQL	QLCD	RESULT	VQL	QLCD	RESULT	VQL	QLCD
1-METHYLNAPHTHALENE	9600 J	9300 J	CMP	9300 J	9300 J	CMP	17000 J	17000 J	CM
2-METHYLNAPHTHALENE	13000 J	12000 J	PM	12000 J	12000 J	MP	29000 J	29000 J	M
ACENAPHTHENE	10500 UJ	10500 UJ	M	10500 UJ	10500 UJ	M	5500 UJ	5500 UJ	M
ACENAPHTHYLENE	10500 UJ	10500 UJ	M	10500 UJ	10500 UJ	M	5500 UJ	5500 UJ	M
ANTHRACENE	10500 UJ	10500 UJ	M	10500 UJ	10500 UJ	M	5500 UJ	5500 UJ	M
BENZO(A)ANTHRACENE	10500 UJ	10500 UJ	M	10500 UJ	10500 UJ	M	5500 UJ	5500 UJ	M
BENZO(A)PYRENE	10500 UJ	10500 UJ	M	10500 UJ	10500 UJ	M	5500 UJ	5500 UJ	M
BENZO(B)FLUORANTHENE	10500 UJ	10500 UJ	M	10500 UJ	10500 UJ	M	5500 UJ	5500 UJ	M
BENZO(G,H,I)PERYLENE	10500 UJ	10500 UJ	M	10500 UJ	10500 UJ	M	5500 UJ	5500 UJ	M
BENZO(K)FLUORANTHENE	10500 UJ	10500 UJ	M	10500 UJ	10500 UJ	M	5500 UJ	5500 UJ	M
CHRYSENE	10500 UJ	10500 UJ	M	10500 UJ	10500 UJ	M	5500 UJ	5500 UJ	M
DIBENZO(A,H)ANTHRACENE	10500 UJ	10500 UJ	M	10500 UJ	10500 UJ	M	5500 UJ	5500 UJ	M
FLUORANTHENE	10500 UJ	10500 UJ	M	10500 UJ	10500 UJ	M	5500 UJ	5500 UJ	M
FLUORENE	2900 J	2800 J	MP	2800 J	2800 J	MP	2300 J	2300 J	MP
INDENO(1,2,3-CD)PYRENE	10500 UJ	10500 UJ	M	10500 UJ	10500 UJ	M	5500 UJ	5500 UJ	M
NAPHTHALENE	10500 UJ	10500 UJ	M	10500 UJ	10500 UJ	M	15000 J	15000 J	M
PHENANTHRENE	13000 J	12000 J	MP	12000 J	11000 J	MP	4200 J	4200 J	MP
PYRENE	9300 J	8100 J	MP	8100 J	8500 J	MP	3200 J	3200 J	MP

PROJ_NO: 02019	NSAMPLE	SN-TN3004B-01	SN-TN3004C-01
SDG: C2745	LAB_ID	C2745-08	C2745-09
FRACTION: PAH	SAMP_DATE	6/16/2011	6/16/2011
MEDIA: SOIL	QC_TYPE	NM	NM
	UNITS	UG/KG	UG/KG
	PCT_SOLIDS	88.0	92.0
	DUP_OF		
PARAMETER	RESULT	VQL	QLCD
1-METHYLNAPHTHALENE	4500 J	CMP	CMP
2-METHYLNAPHTHALENE	5600 J	MP	MP
ACENAPHTHENE	5500 UJ	M	MP
ACENAPHTHYLENE	5500 UJ	M	M
ANTHRACENE	5500 UJ	M	MP
BENZO(A)ANTHRACENE	5500 UJ	M	MP
BENZO(A)PYRENE	5500 UJ	M	M
BENZO(B)FLUORANTHENE	5500 UJ	M	M
BENZO(G,H,I)PERYLENE	5500 UJ	M	M
BENZO(K)FLUORANTHENE	5500 UJ	M	M
CHRYSENE	5500 UJ	M	MP
DIBENZO(A,H)ANTHRACENE	5500 UJ	M	M
FLUORANTHENE	5500 UJ	M	M
FLUORENE	1700 J	MP	MP
INDENO(1,2,3-CD)PYRENE	5500 UJ	M	M
NAPHTHALENE	1400 J	MP	MP
PHENANTHRENE	6900 J	MP	MP
PYRENE	5500 UJ	M	MP
	RESULT	VQL	QLCD
	7800 J	CMP	CMP
	10000 J	MP	MP
	1400 J	MP	MP
	5500 UJ	M	M
	2000 J	MP	MP
	1500 J	MP	MP
	5500 UJ	M	M
	5500 UJ	M	M
	5500 UJ	M	M
	5500 UJ	M	M
	3300 J	MP	MP
	5500 UJ	M	M
	5500 UJ	M	M
	2600 J	MP	MP
	5500 UJ	M	M
	1900 J	MP	MP
	10000 J	MP	MP
	7500 J	MP	MP

PROJ_NO: 02019	NSAMPLE	BP-S1-D	BP-S1-D-DL	BP-S1-UNTREATED	BP-S1-UNTREATED-DL				
SDG: C2745	LAB_ID	C2745-11	C2745-11DL	C2745-10	C2745-10DL				
FRACTION: PCB	SAMP_DATE	6/16/2011	6/16/2011	6/16/2011	6/16/2011				
MEDIA: SOIL	QC_TYPE	NM	NM	NM	NM				
	UNITS	UG/KG	UG/KG	UG/KG	UG/KG				
	PCT_SOLIDS	93.0	93.0	98.0	98.0				
	DUP_OF								
PARAMETER	RESULT	VQL	QLCD	RESULT	VQL	QLCD	RESULT	VQL	QLCD
AROC-LOR-1016		9 UJ	MR		8.5 UJ	MR			
AROC-LOR-1221		9 UJ	MR		8.5 UJ	MR			
AROC-LOR-1232		9 UJ	MR		8.5 UJ	MR			
AROC-LOR-1242				930 J		M		4800 J	M
AROC-LOR-1248		9 UJ	MR		8.5 UJ	MR			
AROC-LOR-1254		9 UJ	MR		8.5 UJ	MR			
AROC-LOR-1260		9 UJ	MR		8.5 UJ	MR			

PROJ_NO: 02019	NSAMPLE	SN-TN3000-01	SN-TN3000-02	SN-TN3000-03	SN-TN3003A-01
SDG: C2745	LAB_ID	C2745-01	C2745-02	C2745-03	C2745-04
FRACTION: PET	SAMP_DATE	6/14/2011	6/14/2011	6/14/2011	6/15/2011
MEDIA: SOIL	QC_TYPE	NM	NM	NM	NM
	UNITS	UG/KG	UG/KG	UG/KG	UG/KG
	PCT_SOLIDS	92.1	92.2	92.4	92.4
	DUP_OF				
PARAMETER	RESULT	VQL	QLCD	RESULT	VQL
DIESEL RANGE ORGANICS	10576586	J	M	12686983	J
	13929439	J	M	21859754	J
					M
					M
					M

PROJ_NO: 02019	NSAMPLE	SN-TN3003B-01	SN-TN3003C-01	SN-TN3004A-01	SN-TN3004B-01
SDG: C2745	LAB_ID	C2745-05	C2745-06	C2745-07	C2745-08
FRACTION: PET	SAMP_DATE	6/15/2011	6/15/2011	6/16/2011	6/16/2011
MEDIA: SOIL	QC_TYPE	NM	NM	NM	NM
	UNITS	UG/KG	UG/KG	UG/KG	UG/KG
	PCT_SOLIDS	93.7	92.4	91.8	88.4
	DUP_OF				
PARAMETER	RESULT	VQL	QLCD	RESULT	VQL
DIESEL RANGE ORGANICS	15998013	J	M	29601212	J
	11563779	J	M	50805359	J
					M
					M
					M

PROJ_NO: 02019	NSAMPLE	SN-TN3004C-01	
SDG: C2745	LAB_ID	C2745-09	
FRACTION: PET	SAMP_DATE	6/16/2011	
MEDIA: SOIL	QC_TYPE	NM	
	UNITS	UG/KG	
	PCT_SOLIDS	92.3	
	DUP_OF		
PARAMETER	RESULT	VQL	QLCD
DIESEL RANGE ORGANICS	10898218	J	M

TO: D. Brayack
FROM: A. Cognetti
DATE: September 30, 2011
SDG: C3384

PAGE: 2

DRO concentration was greater than 14X the spike concentration. No action was taken.

The DRO surrogate spike compound was not detected in the environmental samples due to the dilutions of the samples.

Samples were diluted in the PAH/DRO fraction as shown below.

<u>Sample</u>	<u>Dilution Factor (PAH/DRO)</u>
S4-TN-3001-60 DAYS	10/100
S4-TN-3005A-60DAYS	5/200
S4-TN-3005B-60DAYS	10/200
S4-TN-3005C-60DAYS	10/100

Non-detected results are reported to the Limit of Detection (LOD).

EXECUTIVE SUMMARY

Laboratory Performance Issues: None.

Other Factors Affecting Data Quality: None.

The data for these analyses were reviewed with reference to the SOP #HW-22, Revision #4, USEPA Region II Hazardous Waste Support Branch Validating Semivolatile Organic Compounds by Gas Chromatography/Mass Spectrometry SW-846 Method 8270D (August 2008), and the Department of Defense (DoD) document entitled "Quality Systems Manual (QSM) for Environmental Laboratories" (April 2009).

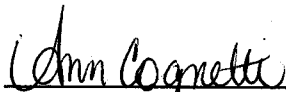

TetraTech NUS
Ann Cognetti
Chemist/Data Validator

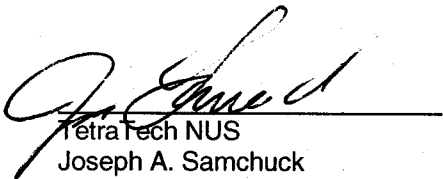

TetraTech NUS
Joseph A. Samchuck
Data Validation Quality Assurance Officer

Attachments:

1. Appendix A - Qualified Analytical Results
2. Appendix B - Results as Reported by the Laboratory
3. Appendix C - Region II Data Validation Forms
4. Appendix D - Support Documentation

Appendix A

Qualified Analytical Results

Data Validation Qualifier Codes:

- A = Lab Blank Contamination
- B = Field Blank Contamination
- C = Calibration Noncompliance (e.g. % RSDs, %Ds, ICVs, CCVs, RRFs, etc.)
- C01 = GC/MS Tuning Noncompliance
- D = MS/MSD Recovery Noncompliance
- E = LCS/LCSD Recovery Noncompliance
- F = Lab Duplicate Imprecision
- G = Field Duplicate Imprecision
- H = Holding Time Exceedance
- I = ICP Serial Dilution Noncompliance
- J = GFAA PDS - GFAA MSA's $r < 0.995$
- K = ICP Interference - includes ICS % R Noncompliance
- L = Instrument Calibration Range Exceedance
- M = Sample Preservation Noncompliance
- N = Internal Standard Noncompliance
- N01 = Internal Standard Recovery Noncompliance Dioxins
- N02 = Recovery Standard Noncompliance Dioxins
- N03 = Clean-up Standard Noncompliance Dioxins
- O = Poor Instrument Performance (e.g. base-line drifting)
- P = Uncertainty near detection limit ($< 2 \times$ IDL for inorganics and $< CRQL$ for organics)
- Q = Other problems (can be any number of issues; e.g. poor chromatography,interferences, etc.)
- R = Surrogates Recovery Noncompliance
- S = Pesticide/PCB Resolution
- T = % Breakdown Noncompliance for DDT and Endrin
- U = % Difference between columns/detectors $>25\%$ for positive results determined via GC/HPLC
- V = Non-linear calibrations; correlation coefficient $r < 0.995$
- W = EMPC result
- X = Signal to noise response drop
- Y = Percent solids $<30\%$
- Z = Uncertainty at 2 sigma deviation is greater than sample activity

PROJ_NO: 02019 SDG: C3384 FRACTION: PAH MEDIA: SOIL	NSAMPLE		S4-TN-3001-60DAYS		S4-TN-3005A-60DAYS		S4-TN-3005B-60DAYS		S4-TN-3005C-60DAYS		
	LAB_ID	C3384-01	RESULT	VQL	QLCD	RESULT	VQL	QLCD	RESULT	VQL	QLCD
	SAMP_DATE	8/10/2011	2100 J	5900	1800 J	1800 J	1800 J	1800 J	3500 J	3500 J	P
	QC_TYPE	NM	5500 U	8500	1800 J	1800 J	1800 J	1800 J	3800 J	3800 J	P
	UNITS	UG/KG	5500 U	2950 U	5500 U	5500 U	5500 U	5500 U	5500 U	5500 U	
	PCT_SOLIDS	90.0	5500 U	2950 U	5500 U	5500 U	5500 U	5500 U	5500 U	5500 U	
	DUP_OF		5500 U	2950 U	5500 U	5500 U	5500 U	5500 U	5500 U	5500 U	
	PARAMETER		5500 U	2950 U	5500 U	5500 U	5500 U	5500 U	5500 U	5500 U	
	1-METHYLNAPHTHALENE		5500 U	2950 U	5500 U	5500 U	5500 U	5500 U	5500 U	5500 U	
	2-METHYLNAPHTHALENE		5500 U	2950 U	5500 U	5500 U	5500 U	5500 U	5500 U	5500 U	
	ACENAPHTHENE		5500 U	2950 U	5500 U	5500 U	5500 U	5500 U	5500 U	5500 U	
	ACENAPHTHYLENE		5500 U	2950 U	5500 U	5500 U	5500 U	5500 U	5500 U	5500 U	
	ANTHRACENE		5500 U	2950 U	5500 U	5500 U	5500 U	5500 U	5500 U	5500 U	
	BENZO(A)ANTHRACENE		5500 U	2950 U	5500 U	5500 U	5500 U	5500 U	5500 U	5500 U	
	BENZO(A)PYRENE		5500 U	2950 U	5500 U	5500 U	5500 U	5500 U	5500 U	5500 U	
	BENZO(B)FLUORANTHENE		5500 U	2950 U	5500 U	5500 U	5500 U	5500 U	5500 U	5500 U	
	BENZO(G,H,I)PERYLENE		5500 U	2950 U	5500 U	5500 U	5500 U	5500 U	5500 U	5500 U	
	BENZO(K)FLUORANTHENE		5500 U	2950 U	5500 U	5500 U	5500 U	5500 U	5500 U	5500 U	
	CHRYSENE		1900 J	2950 U	5500 U	5500 U	5500 U	1900 J	1900 J	1900 J	P
	DIBENZO(A,H)ANTHRACENE		5500 U	2950 U	5500 U	5500 U	5500 U	5500 U	5500 U	5500 U	
	FLUORANTHENE		5500 U	2950 U	5500 U	5500 U	5500 U	5500 U	5500 U	5500 U	
	FLUORENE		5500 U	1500 J	5500 U	5500 U	5500 U	1800 J	1800 J	1800 J	P
	INDENO(1,2,3-CD)PYRENE		5500 U	2950 U	5500 U	5500 U	5500 U	5500 U	5500 U	5500 U	
	NAPHTHALENE		5500 U	2950 U	5500 U	5500 U	5500 U	5500 U	5500 U	5500 U	
	PHENANTHRENE		2500 J	1700 J	5500 U	5500 U	5500 U	2800 J	2800 J	2800 J	P
	PYRENE		5100 J	1900 J	5500 U	5500 U	5500 U	2900 J	2900 J	2900 J	P

051

PROJ_NO: 02019	NSAMPLE	S4-TN-3001-60DAYS	S4-TN-3005A-60DAYS	S4-TN-3005B-60DAYS	S4-TN-3005C-60DAYS
SDG: C3384	LAB_ID	C3384-01	C3384-02	C3384-03	C3384-04
FRACTION: PET	SAMP_DATE	8/10/2011	8/10/2011	8/10/2011	8/10/2011
MEDIA: SOIL	QC_TYPE	NM	NM	NM	NM
	UNITS	UG/KG	UG/KG	UG/KG	UG/KG
	PCT_SOLIDS	89.6	84.3	87.6	86.6
	DUP_OF				
PARAMETER	RESULT	VOL	QLCD	RESULT	VOL
DIESEL RANGE ORGANICS	4562206			7600457	9543379
					3128364

percent differences (RPDs) were greater than the quality control limit for all PAHs for the spiked sample BP-S4-3001-180DAY.

Action: The positive phenanthrene, pyrene, chrysene, and 1-methylnaphthalene results for the sample were qualified estimated, (J). The remainder of the sample PAH analytes were not qualified as analyte results are not qualified based on RPD quality control limit non-compliances alone.

DRO

No issues were identified.

Additional Comments

All samples analyzed for PAHs were diluted 10X resulting in elevated concentrations reported for non-detected analytes. The laboratory narrative stated that samples were diluted in part due to sample matrix affects.

All samples were diluted for the DRO analysis as listed below.

<u>Sample</u>	<u>Dilution</u>
BP-S4-3001-180DAY	100X
BP-S4-3005A-180DAY	200X
BP-S4-3005B-180DAY	200X
BP-S4-3005C-180DAY	100X

The DRO matrix spike (MS) and MS duplicate (MSD) as well as the DRO results MS/MSD relative percent difference (RPD) were non-compliant for spiked sample BP-S4-3005A-180DAY. No validation action was taken as the sample DRO concentration was >5X the DRO spike added to the sample

All samples analyzed for DRO had non-compliant surrogate %Rs. As all samples were analyzed at dilutions this resulted in the diluting out of the surrogates. No validation action was necessary for this issue.

Sample non-detected PAH analyte results were reported to the Limit of Detection (LOD).

Positive results below the Limit of Quantitation (LOQ) and above the Method Detection Limit (MDL) were qualified as estimated, (J), due to uncertainty near the detection limit.

EXECUTIVE SUMMARY

Laboratory Performance Issues: None.

Other Factors Affecting Data Quality: Positive results below the Limit of Quantitation (LOQ) and above the Method Detection Limit (MDL) were qualified as estimated, (J), due to uncertainty near the detection limit. Sample BP-S4-3001-180DAY positive phenanthrene, pyrene, chrysene, and 1-methylnaphthalene results were qualified for MS %R and RPD quality control limit non-compliances.

TO: D. BRAYACK
SDG: C4912

PAGE: 3

The data for these analyses were reviewed with reference to the U.S. EPA Region II SOP HW-22 Revision 4 – August 2008 Validating Semi-volatile Organic Compounds by SW-846 Method 8270D and the Department of Defense (DoD) document entitled “Quality Systems Manual (QSM) for Environmental Laboratories” (April 2009).

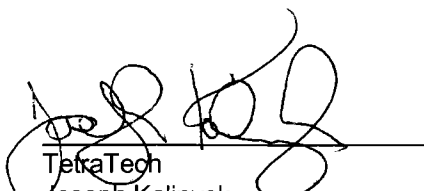

TetraTech
Joseph Kalinyak
Chemist/Data Validator

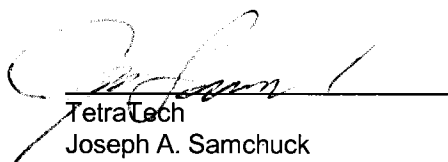

TetraTech
Joseph A. Samchuck
Data Validation Quality Assurance Officer

Attachments:

- Appendix A - Qualified Analytical Results
- Appendix B - Results as Reported by the Laboratory
- Appendix C – Region II Data Validation Forms
- Appendix D - Support Documentation

Appendix A

Qualified Analytical Results

Value Qualifier Key (Val Qual)

J – The result is an estimated quantity. The associated numerical value is the approximate concentration of the analyte in the sample.

UJ – The result is an estimated non-detected quantity. The associated numerical value is the approximate concentration of the analyte in the sample.

U - Value is a non-detect as reported by the laboratory.

UR – Non-detected result is considered rejected, (UR), as a result of technical non-compliances.

DATA QUALIFICATION CODE (QUAL CODE)

Qualifier Codes:

- A = Lab Blank Contamination
- B = Field Blank Contamination
- C = Calibration Noncompliance (i.e., % RSDs, %Ds, ICVs, CCVs, RRFs, etc.)
- C01 = GC/MS Tuning Noncompliance
- D = MS/MSD Recovery Noncompliance
- E = LCS/LCSD Recovery Noncompliance
- F = Lab Duplicate Imprecision
- G = Field Duplicate Imprecision
- H = Holding Time Exceedance
- I = ICP Serial Dilution Noncompliance
- J = ICP PDS Recovery Noncompliance; MSA's $r < 0.995$
- K = ICP Interference - includes ICS % R Noncompliance
- L = Instrument Calibration Range Exceedance
- M = Sample Preservation Noncompliance
- N = Internal Standard Noncompliance
- N01 = Internal Standard Recovery Noncompliance Dioxins
- N02 = Recovery Standard Noncompliance Dioxins
- N03 = Clean-up Standard Noncompliance Dioxins
- O = Poor Instrument Performance (i.e., base-time drifting)
- P = Uncertainty near detection limit ($< 2 \times$ IDL for inorganics and $<$ CRQL for organics)
- Q = Other problems (can encompass a number of issues; i.e.chromatography,interferences, etc.)
- R = Surrogates Recovery Noncompliance
- S = Pesticide/PCB Resolution
- T = % Breakdown Noncompliance for DDT and Endrin
- U = RPD between columns/detectors $>40\%$ for positive results determined via GC/HPLC
- V = Non-linear calibrations; correlation coefficient $r < 0.995$
- W = EMPC result
- X = Signal to noise response drop
- Y = Percent solids $<30\%$
- Z = Uncertainty at 2 sigma deviation is less than sample activity
- Z1 = Tentatively Identified Compound considered presumptively present
- Z2 = Tentatively Identified Compound column bleed

PROJ_NO: 02019 SDG: C4912 FRACTION: PAH MEDIA: SOIL	NSAMPLE		BP-S4-3001-180DAY		BP-S4-3005A-180DAY		BP-S4-3005B-180DAY		BP-S4-3005C-180DAY						
	LAB_ID	SAMP_DATE	QC_TYPE	UNITS	PCT_SOLIDS	DUP_OF	RESULT	VQL	QLCD	RESULT	VQL	QLCD	RESULT	VQL	QLCD
	C4912-04	12/6/2011	NM	UG/KG	98.7		1200 J	6200		1200			1100		
							360	7000		1300			900		
							50 U	50 U		60 U			700		
							50 U	50 U		60 U			50 U		
							50 U	50 U		430			840		
							1200	500		460			1000		
							690	290		260			660		
							480	170		160			370		
							370	250		210			510		
							50 U	50 U		60 U			50 U		
							2400 J	910		870			2000		
							50 U	61 J	P	60 U			130		
							930	380		60 U			810		
							800	50 U		660			1100		
							120	81 J	P	82 J			150		
							50 U	50 U		150			50 U		
							3000 J	2900		2300			3500		
							5400 J	3000		2200			4700		

APPENDIX C
CALCULATIONS

Tetra Tech, Inc.		STANDARD CALCULATION SHEET	
CLIENT:	FILE No:	BY: SK	PAGE: 1 of 12
SUBJECT: Area, Volume, Concentration, and Mass Calculations NWIRP Bethpage, New York		CHECKED BY: DB	DATE: 6/27/2012

1. PURPOSE:

Determine characteristics of total petroleum hydrocarbon (TPH) contamination present in site soils at NWIRP Bethpage, New York. Characteristics include area, volume, concentration, and mass estimates of petroleum bound in isoconcentration contours 1,000 milligrams per kilogram (mg/Kg) to 10,000 mg/Kg TPH and >10,000 mg/Kg TPH.

2. APPROACH:

Use isoconcentration contour mapping as the basis to determine the extent of contamination. Divide the extent of soil contamination into two contours, 1,000 mg/Kg - 10,000 mg/Kg and >10,000 mg/Kg to calculate area, volume, mean concentration within the contour, and mass of petroleum contamination.

Existing data shows the majority of the contamination mass is present at 50 to 70 feet below ground surface (bgs). Figures A-1 to A-7 show an aerial overview of the current extent of contamination based on depth, as used to calculate the 7 depth ranges. See Figure 2-2 and Figures A-8 and A-9 to show outlines of current contamination boundaries.

3. OVERVIEW OF ANALYTICAL DATA AT DEPTH INTERVALS:

0 - 20 feet bgs:

Contamination is limited at this depth. The identified contamination at this depth is defined by soil boring SB103, with a detection of 2,100 mg/Kg. Figure A-1 shows an aerial overview of contamination at this depth.

20 - 30 feet bgs:

Contamination at this depth is in the range of 1,000 mg/Kg to 14,000 mg/Kg, as identified in boring SB101 with a maximum detection of 14,000 mg/Kg at 30 feet bgs. Figure A-2 shows an aerial overview of contamination at this depth.

30 - 40 feet bgs:

Contamination at this depth is in the range of 1,000 mg/Kg to 14,000 mg/Kg, as identified in boring SB101 with a maximum detection of 14,000 mg/Kg at 30 feet bgs. Figure A-3 shows an aerial overview of contamination at this depth.

40 - 50 feet bgs:

Contamination at this depth is in the range of 1,000 mg/Kg to 36,000 mg/Kg, as identified in SB101 with a maximum detection of 36,000 mg/Kg at a depth of 50 feet bgs. This is the most recent maximum detection in site soils. Figure A-4 shows an aerial overview of contamination at this depth.

50 - 60 feet bgs:

Contamination at this depth is mostly greater than 10,000 mg/Kg. It is defined by borings SB101 (36,000 mg/Kg at 50 feet bgs), SB102 (16,000 mg/Kg at 60 feet bgs), and SB103 (23,000 mg/Kg at 60 feet bgs). Figure A-5 shows an aerial overview of contamination at this depth.

60 - 70 feet bgs:

Contamination at this depth is in the range of 1,000 mg/Kg to greater than 10,000 mg/Kg. Peak concentrations are in borings SB101 (25,000 mg/Kg at 60 feet bgs) and SB103 (23,000 mg/Kg at 60 feet bgs). Figure A-6 shows an aerial overview of contamination at this depth.

70 - 80 feet bgs:

Contamination at this depth is limited. Clean soils were detected at approximately 73 feet bgs. Figure A-7 shows an aerial overview of contamination at this depth.

Tetra Tech, Inc.		STANDARD CALCULATION SHEET	
CLIENT:	FILE No:	BY: SK	PAGE: 2 of 12
SUBJECT: Area, Volume, Concentration, and Mass Calculations NWIRP Bethpage, New York		CHECKED BY: DB	DATE: 6/27/2012

4.0 ASSUMPTIONS AND CONVERSION FACTORS:

The following values will be used as constant values or conversion factors in the calculations:

*Average soil density of sandy soils:	1,800 Kg/m ³	=	112 lb/ft ³
*Typical soil porosity of sandy soils:	25 %		
1 m ³	=	35.32 ft ³	
1 yd ³	=	27 ft ³	
1 Kg	=	1,000,000 mg	
1 Kg	=	2.205 lbm	
*Specific gravity (SG) of fuel oil	=	1 $\frac{\text{lbm TPH/ft}^3}{\text{lbm water/ft}^3}$	
density water	=	62.4 lbm/ft ³	
1 gallon	=	0.1337 ft ³	
SG	=	1 = $\frac{\text{X lb contaminant/ft}^3}{62.4 \text{ lb water/ft}^3}$	
Therefore density TPH	=	62.4 lb TPH/ft ³	= 8.34 lb/gallon

Reference of soil density and porosity:

Watts, Richard J. Hazardous Wastes: Sources, Pathways, and Receptors. Page 264.

Reference of specific gravity:

Tetra Tech, 2012. *Technical Memorandum Site 4 Bench Scale Studies*. July.

Tetra Tech, Inc.		STANDARD CALCULATION SHEET	
CLIENT:	FILE No:	BY: SK	PAGE: 3 of 12
SUBJECT: Area, Volume, Concentration, and Mass Calculations NWIRP Bethpage, New York		CHECKED BY: DB	DATE: 6/27/2012

5.0 FOR THE DEPTH OF 0 TO 20 FEET BGS, CALCULATE THE VOLUME OF CONTAMINATED SOIL, MEAN CONCENTRATION WITHIN THE 1,000 - 10,000 mg/Kg TPH and >10,000 mg/Kg TPH ISOCONCENTRATION (ISOCONC.) CONTOURS, AND CALCULATE THE MASS OF TPH.

[See Figure A-1, A-8, and A-9]

5.1 CALCULATE VOLUME

>1,000 mg/Kg TPH Contour

Individual TPH Isoconc. Contour	Length of Isoconc. Contour (feet)	Width of Isoconc. Contour (feet)	Area of Isoconc. Contour (square feet (ft ²))	Contaminant Thickness (feet)	Volume of Isoconc. Contour (cubic feet (ft ³))	Depth of Contamination (feet below ground surface (feet bgs))
A-1	15	15	225	3	675	17-20
A-2	17	15	255	3	765	17-20
A-3	10	5	50	3	150	17-20
SUM					1,600	

>10,000 mg/Kg TPH Contour⁽¹⁾

Individual TPH Isoconc. Contour	Length of Isoconc. Contour (feet)	Width of Isoconc. Contour (feet)	Area of Isoconc. Contour (ft ²)	Contaminant Thickness (feet)	Volume of Isoconc. Contour (ft ³)	Depth of Contamination (feet bgs)
>10,000	0	0	0	0	0	0

⁽¹⁾ No detection greater than 10,000 mg/Kg TPH in this depth range.

5.2 CALCULATE MEAN CONCENTRATION

Isoconc. Contour	Volume of Isoconc. Contour (ft ³)	Volume of Isoconc. Contour (cubic yards (yd ³))	Minimum TPH Concentration Within Contour (mg/Kg)	Maximum TPH Concentration Within Contour (mg/Kg)	Geometric Mean Concentration of TPH Within Contour (mg/Kg) ⁽²⁾
1,000 - 10,000	1,600	60	1,000	2,100	1,400
>10,000	0	0	0	0	0

⁽²⁾ Mean concentration is equal to the geometric mean and calculated as follows:

$$\begin{aligned} \text{Mean Concentration} &= (1,000 \text{ mg/Kg} * 2,100 \text{ mg/Kg})^{(1/2)} \\ &= 1,400 \text{ mg/Kg} \end{aligned}$$

Total Volume Contaminated Soil in Contour 1,000 - 10,000 TPH:	1,600 ft ³	=	60 yd ³
Total Volume Contaminated Soil in Contour >10,000 TPH:	0 ft ³	=	0 yd ³

Tetra Tech, Inc.		STANDARD CALCULATION SHEET	
CLIENT:	FILE No:	BY: SK	PAGE: 4 of 12
SUBJECT: Area, Volume, Concentration, and Mass Calculations NWIRP Bethpage, New York		CHECKED BY: DB	DATE: 6/27/2012

5.3 ESTIMATE MASS OF TPH FOR THE DEPTH OF 0 TO 20 FEET.

Isoconc. Contour	Geometric Mean Concentration of TPH Within Contour (mg/Kg)	Volume of Isoconc. Contour (ft ³)	Volume of Isoconc. Contour (yd ³)	Mass TPH (pounds) ⁽³⁾	Mass TPH (gallons) ⁽³⁾
1,000 - 10,000	1,400	1,600	60	250	30
>10,000	0	0	0	0	0

⁽³⁾ Example calculation for mass of TPH:

$$\begin{array}{rcl}
 \text{Mass} = & 1,600 \text{ ft}^3 \times & \frac{112 \text{ lb soil}}{\text{ft}^3} \times \frac{1,400 \text{ mg TPH}}{1,000,000 \text{ mg soil}} = & 250 \text{ lbs TPH} \\
 & 250 \text{ lbs TPH} \times \frac{1 \text{ gallon}}{8.34 \text{ lbs TPH}} & = & 30 \text{ gallons TPH}
 \end{array}$$

Tetra Tech, Inc.		STANDARD CALCULATION SHEET	
CLIENT:	FILE No:	BY: SK	PAGE: 6 of 12
SUBJECT: Area, Volume, Concentration, and Mass Calculations NWIRP Bethpage, New York		CHECKED BY: DB	DATE: 6/27/2012

7.0. FOR THE DEPTH INTERVAL OF 30 TO 40 FEET BGS, CALCULATE THE VOLUME OF CONTAMINATED SOIL, MEAN CONCENTRATION WITHIN THE 1,000 - 10,000 mg/Kg TPH and >10,000 mg/Kg TPH ISOCONCENTRATION (ISOCONC.) CONTOURS, AND CALCULATE THE MASS OF TPH.

[See Figure A-3, A-8, and A-9]

7.1 CALCULATE VOLUME

>1,000 mg/Kg TPH Contour

Individual TPH Isoconc. Contour	Length of Isoconc. Contour (feet)	Width of Isoconc. Contour (feet)	Area of Isoconc. Contour (square feet (ft ²))	Contaminant Thickness (feet)	Volume of Isoconc. Contour (cubic feet (ft ³))	Depth of Contamination (feet below ground surface (feet bgs))
A ₁	80	40	3,200	10	32,000	30-40
SUM					32,000	

>10,000 mg/Kg TPH Contour

Individual TPH Isoconc. Contour	Length of Isoconc. Contour (feet)	Width of Isoconc. Contour (feet)	Area of Isoconc. Contour (ft ²)	Contaminant Thickness (feet)	Volume of Isoconc. Contour (ft ³)	Depth of Contamination (feet bgs)
A ₁	15	10	150	5	750	30-37
SUM					750	

7.2 CALCULATE MEAN CONCENTRATION

Isoconc. Contour	Volume of Isoconc. Contour (ft ³)	Volume of Isoconc. Contour (cubic yards (yd ³))	Minimum TPH Concentration Within Contour (mg/Kg)	Maximum TPH Concentration Within Contour (mg/Kg)	Geometric Mean Concentration of TPH Within Contour (mg/Kg)
1,000 - 10,000	31,000	1,100	1,000	6,100	2,500
>10,000	750	30	10,000	14,000	12,000

Total Volume Contaminated Soil in Contour 1,000 - 10,000 TPH: 31,000 ft³ = 1,100 yd³

Total Volume Contaminated Soil in Contour >10,000 TPH: 750 ft³ = 30 yd³

7.3 ESTIMATE MASS OF TPH FOR THE DEPTH OF 30 TO 40 FEET.

Isoconc. Contour	Geometric Mean Concentration of TPH Within Contour (mg/Kg)	Volume of Isoconc. Contour (ft ³)	Volume of Isoconc. Contour (yd ³)	Mass TPH (pounds)	Mass TPH (gallons)
1,000 - 10,000	2,500	31,000	1,100	8,700	1,043
>10,000	12,000	750	30	1,000	120

Tetra Tech, Inc.		STANDARD CALCULATION SHEET	
CLIENT:	FILE No:	BY: SK	PAGE: 7 of 12
SUBJECT: Area, Volume, Concentration, and Mass Calculations NWIRP Bethpage, New York		CHECKED BY: DB	DATE: 6/27/2012

8.0 FOR THE DEPTH OF 40 TO 50 FEET BGS, CALCULATE THE VOLUME OF CONTAMINATED SOIL, MEAN CONCENTRATION WITHIN THE 1,000 - 10,000 mg/Kg TPH and >10,000 mg/Kg TPH ISOCONCENTRATION (ISOCONC.) CONTOURS, AND CALCULATE THE MASS OF TPH.

[See Figure A-4, A-8, and A-9]

8.1 CALCULATE VOLUME

>1,000 mg/Kg TPH Contour

Individual TPH Isoconc. Contour	Length of Isoconc. Contour (feet)	Width of Isoconc. Contour (feet)	Area of Isoconc. Contour (square feet (ft ²))	Contaminant Thickness (feet)	Volume of Isoconc. Contour (cubic feet (ft ³))	Depth of Contamination (feet below ground surface (feet bgs))
A ₁	84	55	4,600	10	46,000	40-50

SUM

46,000

>10,000 mg/Kg TPH Contour

Individual TPH Isoconc. Contour	Length of Isoconc. Contour (feet)	Width of Isoconc. Contour (feet)	Area of Isoconc. Contour (ft ²)	Contaminant Thickness (feet)	Volume of Isoconc. Contour (ft ³)	Depth of Contamination (feet bgs)
A ₁	20	13	260	7	1,800	40-48

SUM

1,800

8.2 CALCULATE MEAN CONCENTRATION

Isoconc. Contour	Volume of Isoconc. Contour (ft ³)	Volume of Isoconc. Contour (cubic yards (yd ³))	Minimum TPH Concentration Within Contour (mg/Kg)	Maximum TPH Concentration Within Contour (mg/Kg)	Geometric Mean Concentration of TPH Within Contour (mg/Kg)
1,000 - 10,000	44,000	1,600	1,000	6,100	2,500
>10,000	1,800	70	10,000	36,000	19,000

Total Volume Contaminated Soil in Contour
1,000 - 10,000 TPH:

44,000 ft³

=

1,600 yd³

Total Volume Contaminated Soil in Contour
>10,000 TPH:

1,800 ft³

=

70 yd³

8.3 ESTIMATE MASS OF TPH FOR THE DEPTH OF 40 TO 50 FEET.

Isoconc. Contour	Geometric Mean Concentration of TPH Within Contour (mg/Kg)	Volume of Isoconc. Contour (ft ³)	Volume of Isoconc. Contour (yd ³)	Mass TPH (pounds)	Mass TPH (gallons)
1,000 - 10,000	2,500	44,000	1,600	12,000	1,439
>10,000	19,000	1,800	70	3,800	456

Tetra Tech, Inc.		STANDARD CALCULATION SHEET	
CLIENT:	FILE No:	BY: SK	PAGE: 8 of 12
SUBJECT: Area, Volume, Concentration, and Mass Calculations NWIRP Bethpage, New York		CHECKED BY: DB	DATE: 6/27/2012

9.0 FOR THE DEPTH OF 50 TO 60 FEET BGS, CALCULATE THE VOLUME OF CONTAMINATED SOIL, MEAN CONCENTRATION WITHIN THE 1,000 - 10,000 mg/Kg TPH and >10,000 mg/Kg TPH ISOCONCENTRATION (ISOCONC.) CONTOURS, AND CALCULATE THE MASS OF TPH.

[See Figure A-5, A-8, and A-9]

9.1 CALCULATE VOLUME

>1,000 mg/Kg TPH Contour

Individual TPH Isoconc. Contour	Length of Isoconc. Contour (feet)	Width of Isoconc. Contour (feet)	Area of Isoconc. Contour (square feet (ft ²))	Contaminant Thickness (feet)	Volume of Isoconc. Contour (cubic feet (ft ³))	Depth of Contamination (feet below ground surface (feet bgs))
A ₁	80	75	6,000	10	60,000	50-60

SUM

60,000

>10,000 mg/Kg TPH Contour

Individual TPH Isoconc. Contour	Length of Isoconc. Contour (feet)	Width of Isoconc. Contour (feet)	Area of Isoconc. Contour (ft ²)	Contaminant Thickness (feet)	Volume of Isoconc. Contour (ft ³)	Depth of Contamination (feet bgs)
A ₁	60	60	3,600	8	29,000	50-58

SUM

29,000

9.2 CALCULATE MEAN CONCENTRATION

Isoconc. Contour	Volume of Isoconc. Contour (ft ³)	Volume of Isoconc. Contour (cubic yards (yd ³))	Minimum TPH Concentration Within Contour (mg/Kg)	Maximum TPH Concentration Within Contour (mg/Kg)	Geometric Mean Concentration of TPH Within Contour (mg/Kg)
1,000 - 10,000	31,000	1,100	1,000	3,400	1,800
>10,000	29,000	1,100	10,000	23,000	15,000

Total Volume Contaminated Soil in Contour

1,000 - 10,000 TPH:

31,000 ft³

=

1,100 yd³

Total Volume Contaminated Soil in Contour

>10,000 TPH:

29,000 ft³

=

1,100 yd³

9.3 ESTIMATE MASS OF TPH FOR THE DEPTH OF 50 TO 60 FEET.

Isoconc. Contour	Geometric Mean Concentration of TPH Within Contour (mg/Kg)	Volume of Isoconc. Contour (ft ³)	Volume of Isoconc. Contour (yd ³)	Mass TPH (pounds)	Mass TPH (gallons)
1,000 - 10,000	1,800	31,000	1,100	6,000	719
>10,000	15,000	29,000	1,100	49,000	5,875

CLIENT:	FILE No:	BY: SK	PAGE: 10 of 12
SUBJECT: Area, Volume, Concentration, and Mass Calculations NWIRP Bethpage, New York		CHECKED BY: DB	DATE: 6/27/2012

10.3 ESTIMATE MASS OF TPH FOR THE DEPTH OF 60 TO 70 FEET.

Isoconc. Contour	Geometric Mean Concentration of TPH Within Contour (mg/Kg)	Volume of Isoconc. Contour (ft ³)	Volume of Isoconc. Contour (yd ³)	Mass TPH (pounds)	Mass TPH (gallons)
1,000 - 10,000	1,600	26,000	960	4,700	564
>10,000	13,000	2,800	100	4,100	492

Tetra Tech, Inc.		STANDARD CALCULATION SHEET	
CLIENT:	FILE No:	BY: SK	PAGE: 11 of 12
SUBJECT: Area, Volume, Concentration, and Mass Calculations NWIRP Bethpage, New York		CHECKED BY: DB	DATE: 6/27/2012

11.0 FOR THE DEPTH OF 70 TO 80 FEET BGS, CALCULATE THE VOLUME OF CONTAMINATED SOIL, MEAN CONCENTRATION WITHIN THE 1,000 -10,000 mg/Kg TPH and >10,000 mg/Kg TPH ISOCONCENTRATION (ISOCONC.) CONTOURS, AND CALCULATE THE MASS OF TPH.

[See Figure A-7, A-8, and A-9]

11.1 CALCULATE VOLUME

>1,000 mg/Kg TPH Contour

Individual TPH Isoconc. Contour	Length of Isoconc. Contour (feet)	Width of Isoconc. Contour (feet)	Area of Isoconc. Contour (square feet (ft ²))	Contaminant Thickness (feet)	Volume of Isoconc. Contour (cubic feet (ft ³))	Depth of Contamination (feet below ground surface (feet bgs))
A ₁	10	8	80	2	160	70-72
A ₂	10	10	100	2	200	70-72
SUM					360	

>10,000 mg/Kg TPH Contour*

Individual TPH Isoconc. Contour	Length of Isoconc. Contour (feet)	Width of Isoconc. Contour (feet)	Area of Isoconc. Contour (ft ²)	Contaminant Thickness (feet)	Volume of Isoconc. Contour (ft ³)	Depth of Contamination (feet bgs)
>10,000	0	0	0	0	0	0

*No detection greater than 10,000 mg/Kg TPH in this depth range.

11.2 CALCULATE MEAN CONCENTRATION

Isoconc. Contour	Volume of Isoconc. Contour (ft ³)	Volume of Isoconc. Contour (cubic yards (yd ³))	Minimum TPH Concentration Within Contour (mg/Kg)	Maximum TPH Concentration Within Contour (mg/Kg)	Geometric Mean Concentration of TPH Within Contour (mg/Kg)
1,000 - 10,000	360	10	1,000	5,100	2,300
>10,000	0	0	0	0	0

Total Volume Contaminated Soil in Contour 1,000 - 10,000 TPH: $360 \text{ ft}^3 = 10 \text{ yd}^3$

Total Volume Contaminated Soil in Contour >10,000 TPH: $0 \text{ ft}^3 = 0 \text{ yd}^3$

11.3 ESTIMATE MASS OF TPH FOR THE DEPTH OF 70 TO 80 FEET.

Isoconc. Contour	Geometric Mean Concentration of TPH Within Contour (mg/Kg)	Volume of Isoconc. Contour (ft ³)	Volume of Isoconc. Contour (yd ³)	Mass TPH (pounds)	Mass TPH (gallons)
1,000 - 10,000	2,300	360	10	90	11
>10,000	0	0	0	0	0

Tetra Tech, Inc.		STANDARD CALCULATION SHEET	
CLIENT:	FILE No:	BY: SK	PAGE: 12 of 12
SUBJECT: Area, Volume, Concentration, and Mass Calculations NWIRP Bethpage, New York		CHECKED BY: DB	DATE: 11/12/2012

12.0 ESTIMATE TOTAL MASS IN AOC 22

UNSATURATED SOILS (0 to 50 feet bgs)

Isoconc. Contour	Volume of Isoconc. Contour (ft ³)	Volume of Isoconc. Contour (yd ³)	Mass TPH (pounds)	Mass TPH (gallons)
1,000 - 10,000	94,000	3,400	24,000	2,860
>10,000	3,300	130	5,800	696
SUM	97,000	3,500	30,000	3,600
% OF TOTAL	51	51	32	32

SATURATED SOILS (50 to 80 feet bgs)

Isoconc. Contour	Volume of Isoconc. Contour (ft ³)	Volume of Isoconc. Contour (yd ³)	Mass TPH (pounds)	Mass TPH (gallons)
1,000 - 10,000	57,000	2,100	11,000	1,300
>10,000	32,000	1,200	53,000	6,400
SUM	89,000	3,300	64,000	7,700
% OF TOTAL	47	49	68	68

TOTAL MASS

Isoconc. Contour	Volume of Isoconc. Contour (ft ³)	Volume of Isoconc. Contour (yd ³)	Mass TPH (pounds)	Mass TPH (gallons)
1,000 - 10,000	150,000	5,500	35,000	4,200
>10,000	35,000	1,300	59,000	7,100
SUM	190,000	6,800	94,000	11,300

12.1 ESTIMATE AMOUNT OF RECOVERABLE FREE PRODUCT

Isoconc. Contour	Mass TPH (gallons)	Recoverable Free Product (gallons) ⁽¹⁾	Mass TPH (tons)
1,000 - 10,000	4,200	3,360	20
>10,000	7,100	5,700	30
SUM	11,300	9,100	47

⁽¹⁾ Assume 80% of existing free product (equal to the mass of TPH in gallons) is recoverable for Alternative 3 Steam Injection.

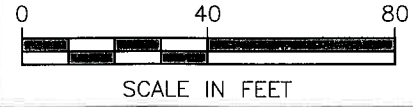
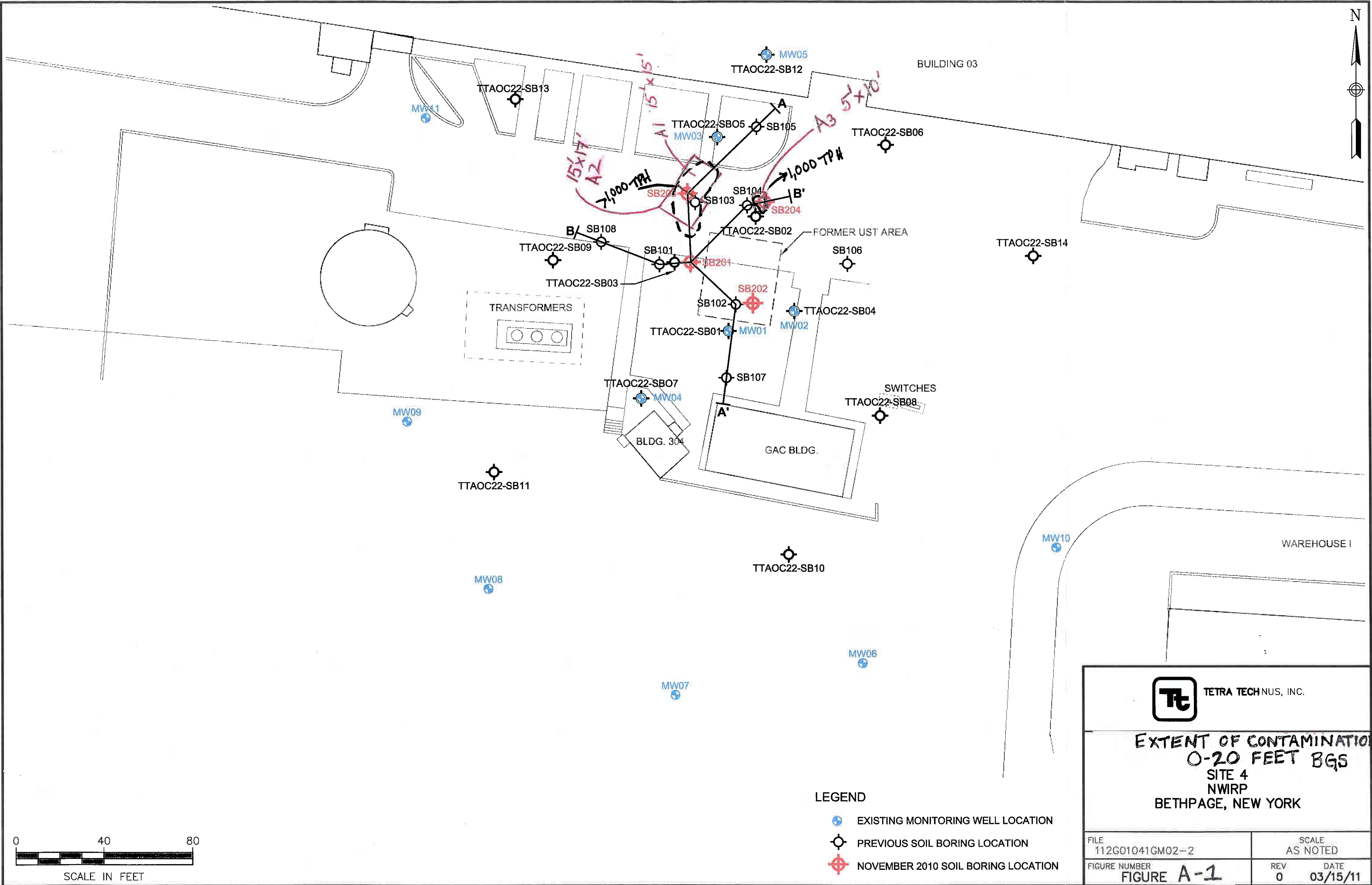
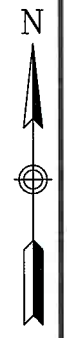

- LEGEND
- EXISTING MONITORING WELL LOCATION
 - PREVIOUS SOIL BORING LOCATION
 - NOVEMBER 2010 SOIL BORING LOCATION

TETRA TECHNUS, INC.	
EXTENT OF CONTAMINATION 0-20 FEET BGS SITE 4 NWIRP BETHPAGE, NEW YORK	
FILE 112G01041GM02-2	SCALE AS NOTED
FIGURE NUMBER FIGURE A-1	REV DATE 0 03/15/11

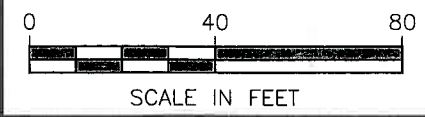
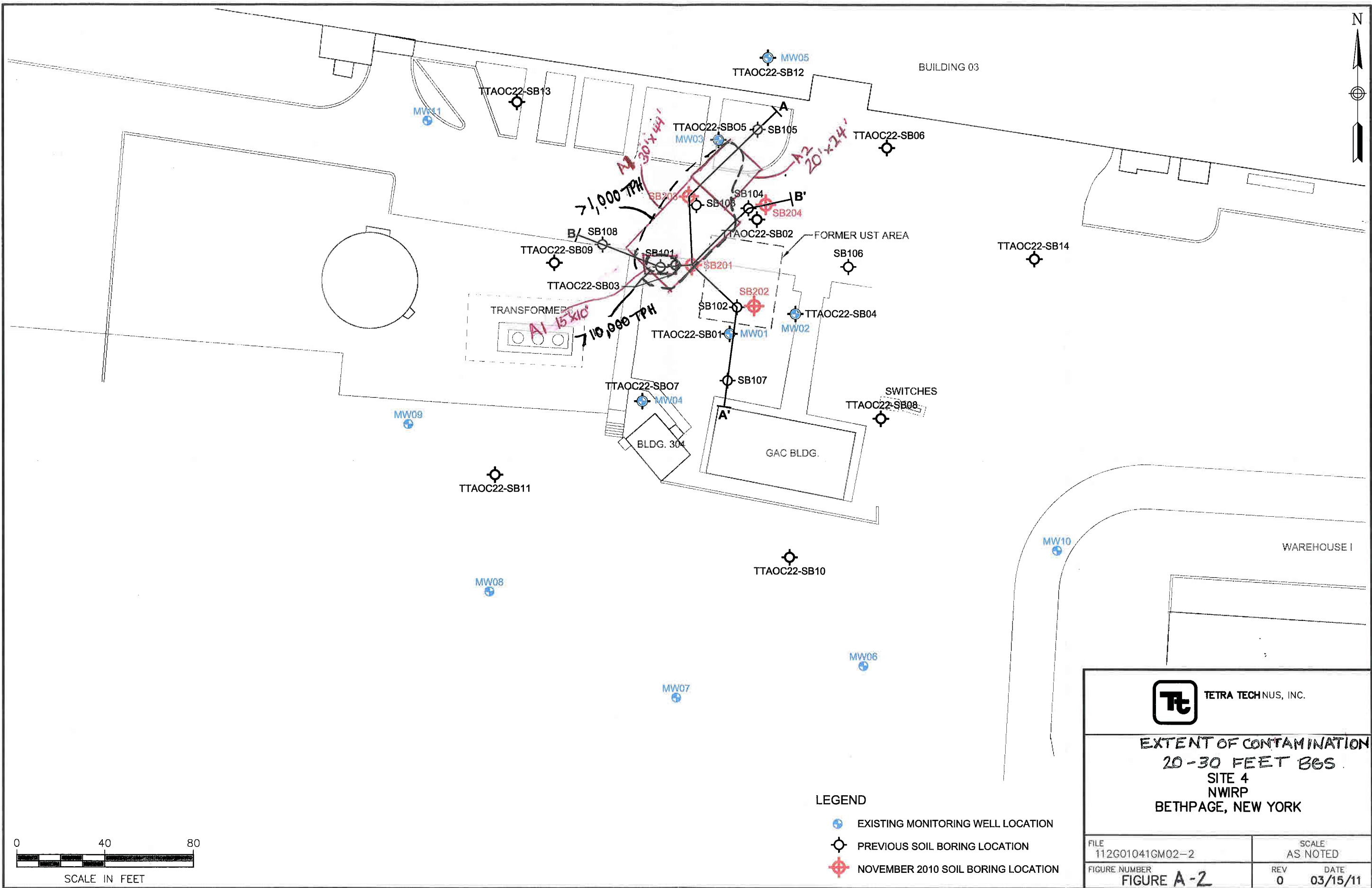

- LEGEND
- EXISTING MONITORING WELL LOCATION
 - PREVIOUS SOIL BORING LOCATION
 - NOVEMBER 2010 SOIL BORING LOCATION

TETRA TECHNUS, INC.	
EXTENT OF CONTAMINATION 20-30 FEET BGS SITE 4 NWIRP BETHPAGE, NEW YORK	
FILE 112G01041GM02-2	SCALE AS NOTED
FIGURE NUMBER FIGURE A-2	REV DATE 0 03/15/11

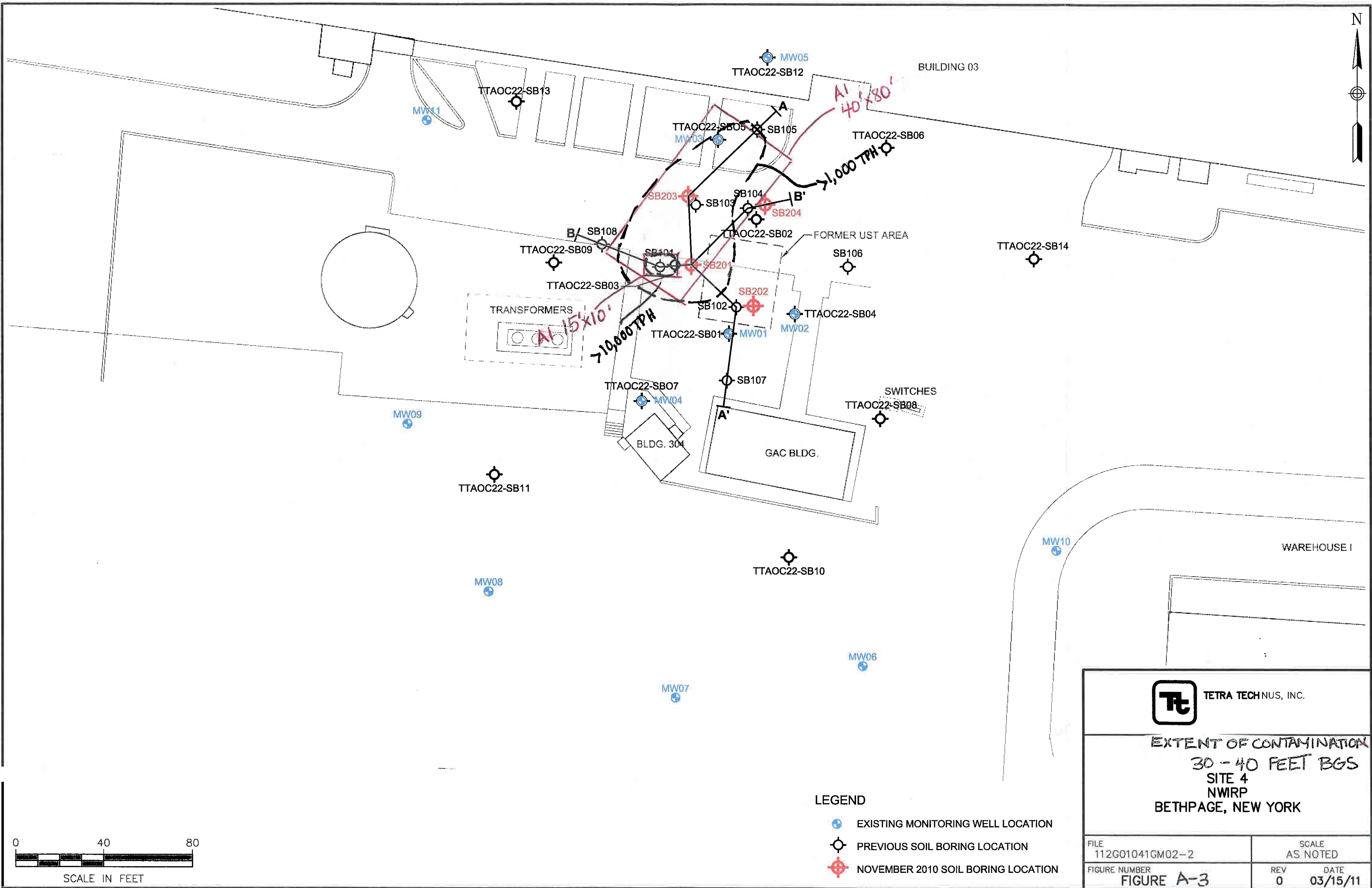

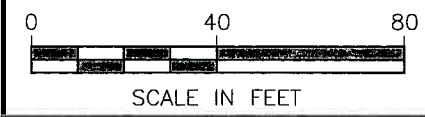
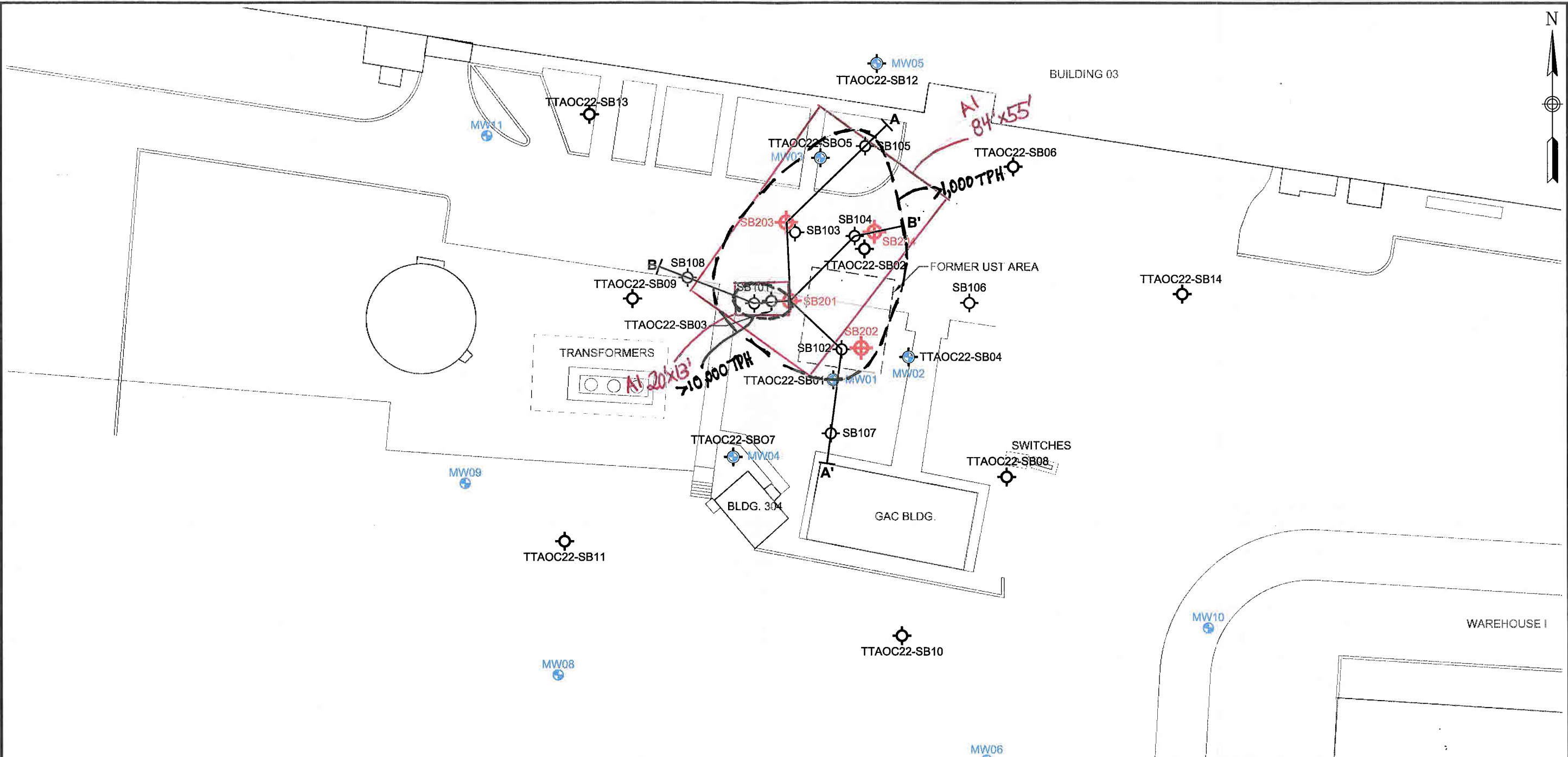

- LEGEND**
- EXISTING MONITORING WELL LOCATION
 - PREVIOUS SOIL BORING LOCATION
 - NOVEMBER 2010 SOIL BORING LOCATION

TETRA TECHNUS, INC.	
EXTENT OF CONTAMINATION 40-50 FEET BGS SITE 4 NWIRP BETHPAGE, NEW YORK	
FILE 112G01041GM02-2	SCALE AS NOTED
FIGURE NUMBER FIGURE A-4	REV DATE 0 03/15/11

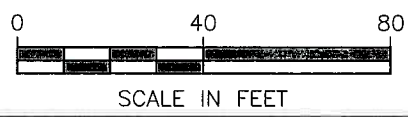
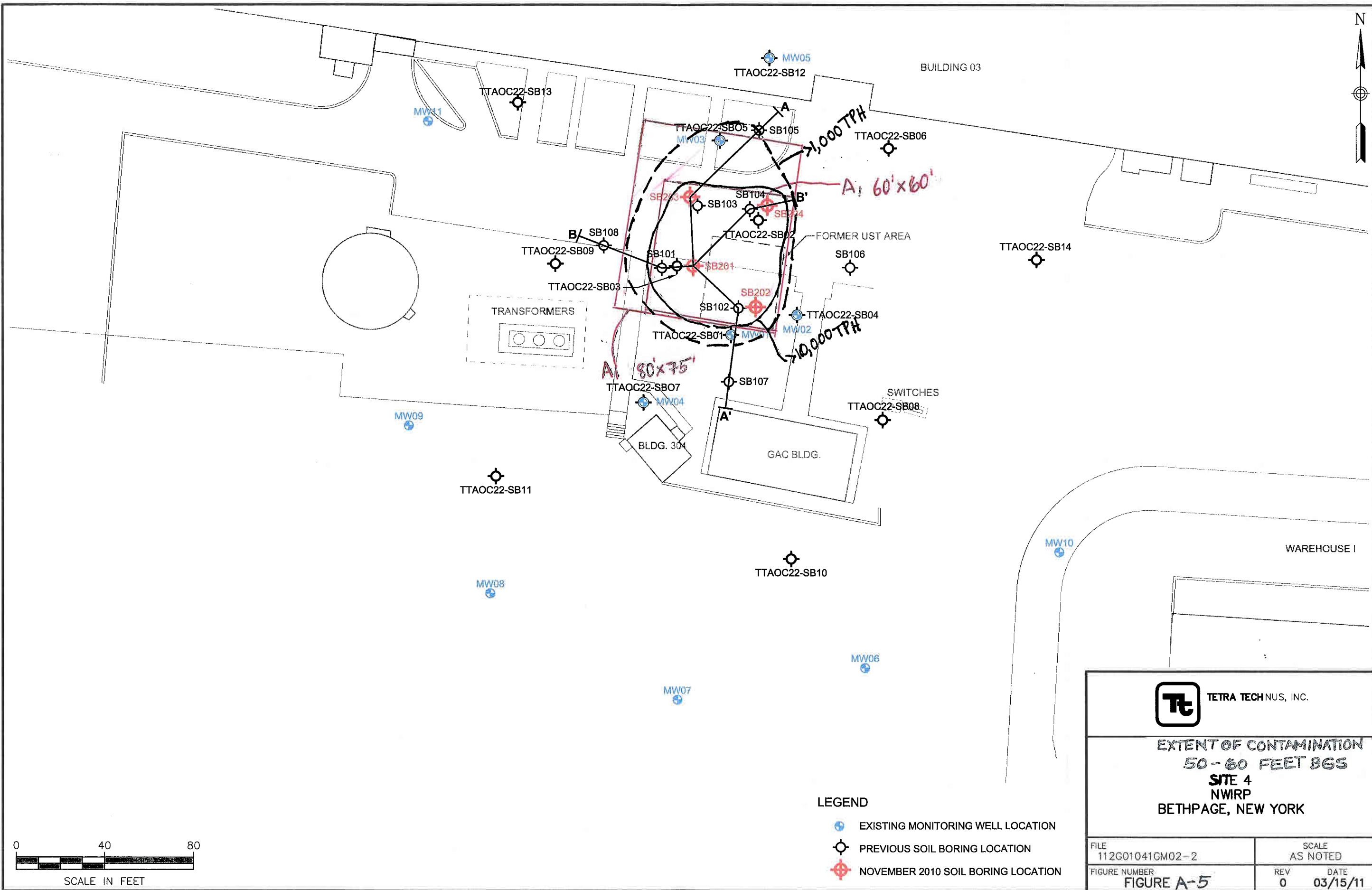

- LEGEND
- EXISTING MONITORING WELL LOCATION
 - PREVIOUS SOIL BORING LOCATION
 - NOVEMBER 2010 SOIL BORING LOCATION

TETRA TECHNUS, INC.	
EXTENT OF CONTAMINATION 50-60 FEET BGS SITE 4 NWIRP BETHPAGE, NEW YORK	
FILE 112G01041GM02-2	SCALE AS NOTED
FIGURE NUMBER FIGURE A-5	REV DATE 0 03/15/11

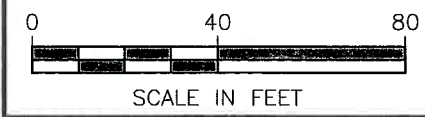

- LEGEND**
- EXISTING MONITORING WELL LOCATION
 - PREVIOUS SOIL BORING LOCATION
 - NOVEMBER 2010 SOIL BORING LOCATION

TETRA TECHNUS, INC.	
EXTENT OF CONTAMINATION 60 - 70 FEET BGS SITE 4 NWIRP BETHPAGE, NEW YORK	
FILE 112G01041GM02-2	SCALE AS NOTED
FIGURE NUMBER FIGURE A-6	REV DATE 0 03/15/11

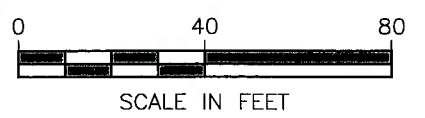
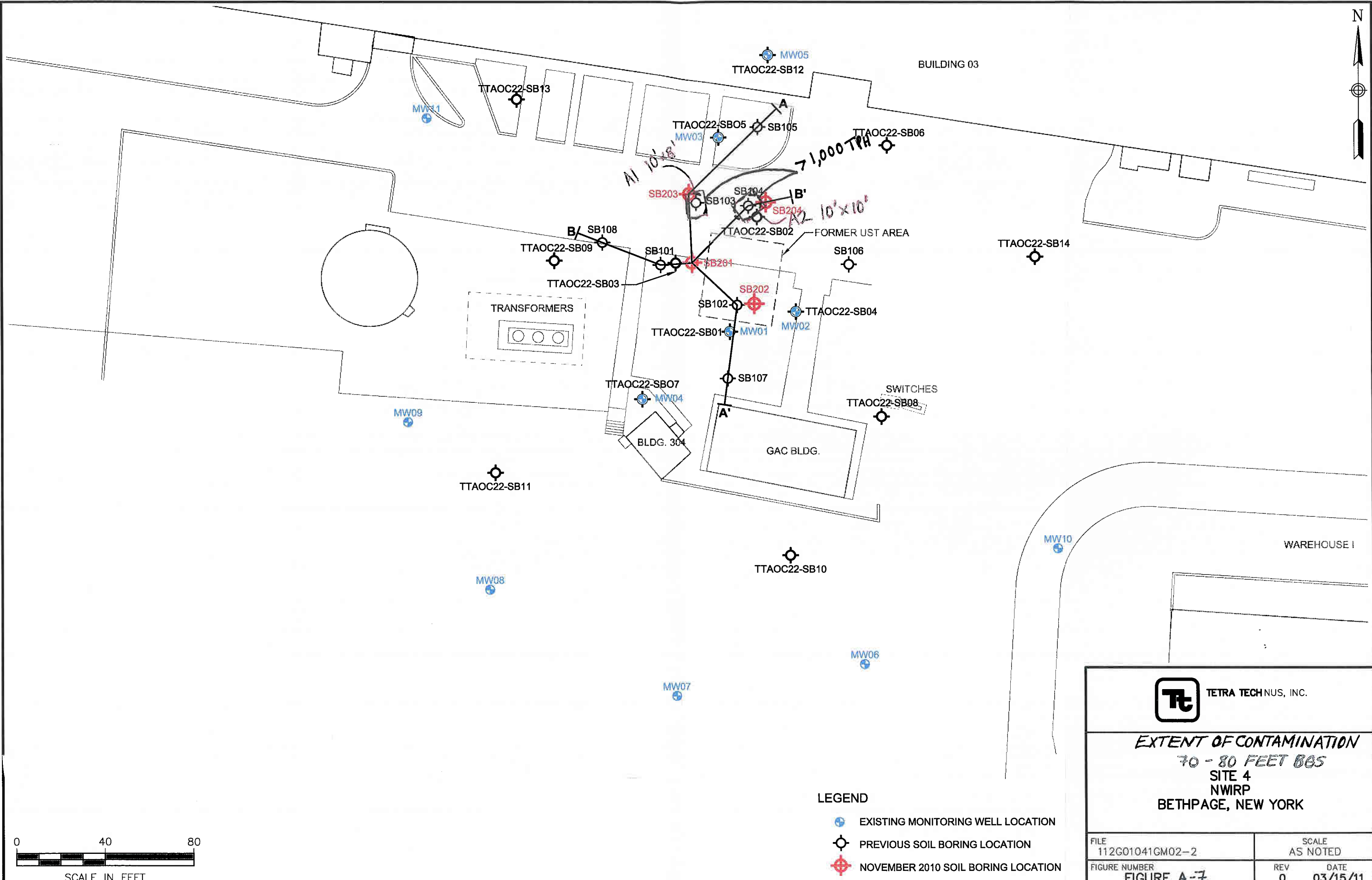

- LEGEND**
- EXISTING MONITORING WELL LOCATION
 - PREVIOUS SOIL BORING LOCATION
 - NOVEMBER 2010 SOIL BORING LOCATION

 TETRA TECHNUS, INC.	
EXTENT OF CONTAMINATION 70 - 80 FEET BOS SITE 4 NWIRP BETHPAGE, NEW YORK	
FILE 112G01041GM02-2	SCALE AS NOTED
FIGURE NUMBER FIGURE A-7	REV DATE 0 03/15/11

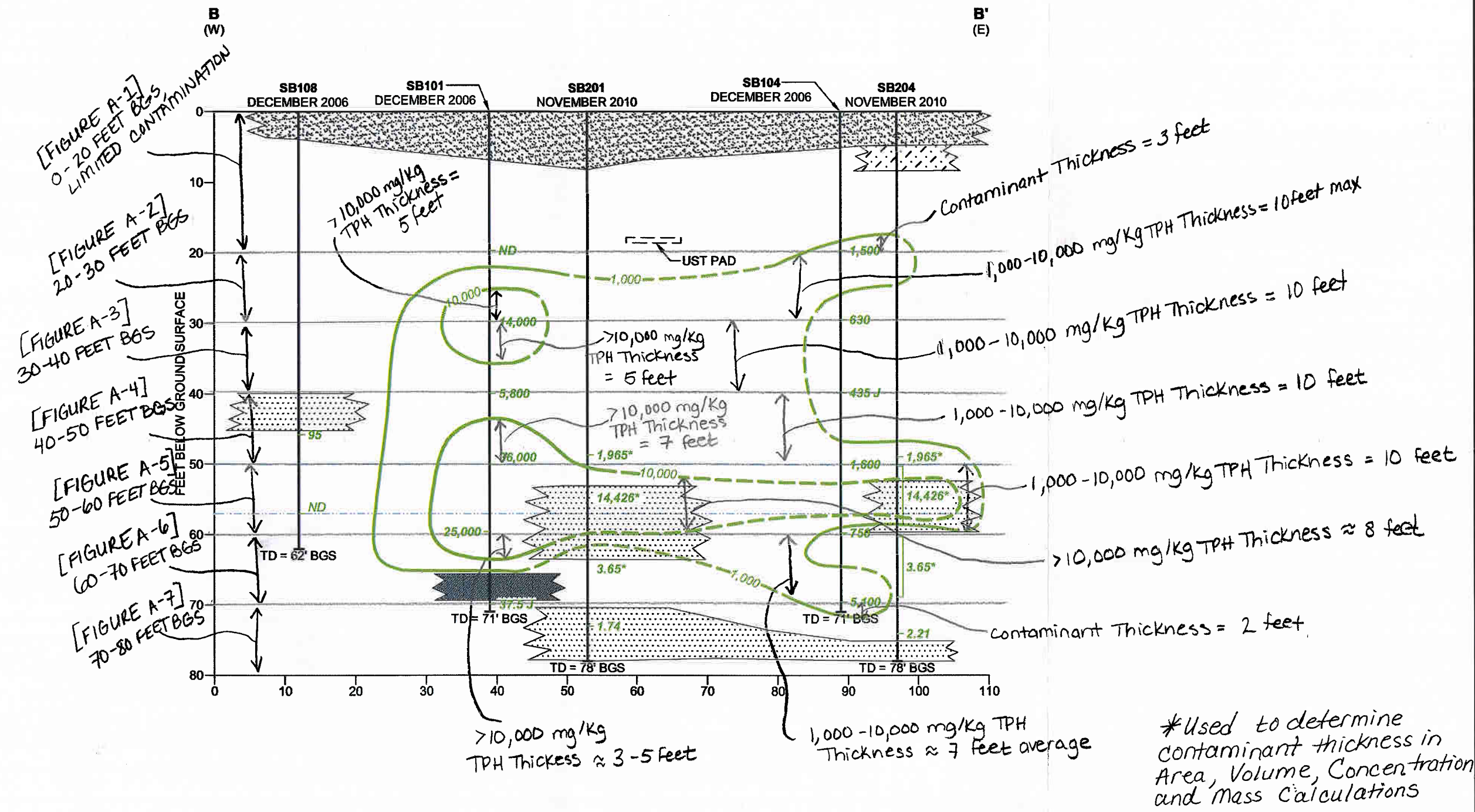

- LEGEND**
- SAND WITH GRAVEL/ASPHALT/CONCRETE
 - F-C SAND WITH TRACE CLAY, GRAVEL AND SILT
 - SILTY SAND
 - CLAYEY SILT
 - CLAYEY SAND
 - TPH (1,000 mg/kg CONTOUR LINE) (DASHED WHERE INFERRED)

- TPH (10,000 mg/kg CONTOUR LINE) (DASHED WHERE INFERRED)
- SB102 SOIL BORING
- * COMPOSITE OF SB201 AND SB204
- 5,300 TPH RESULT IN mg/kg
- TD = 58' BGS TOTAL DEPTH (BGS) BELOW GROUND SURFACE
- ND TPH NOT DETECTED

*Used to determine contaminant thickness in Area, Volume, Concentration, and Mass Calculations



CROSS SECTION B - B'
SITE 4
NWIRP
BETHPAGE, NEW YORK

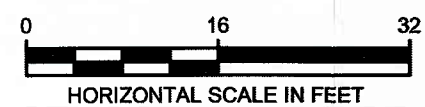

FILE 112G02751GS02	SCALE AS NOTED
FIGURE NUMBER FIGURE A-9	REV 0
	DATE 05/21/12

Tetra Tech, Inc.		STANDARD CALCULATION SHEET	
CLIENT:	FILE No:	BY: SK	PAGE: 1 of 4
SUBJECT: Alternative 3 Steam Injection Heat Requirements NWIRP Bethpage Site 4 FS		CHECKED BY: DB	DATE: 7/10/2012

1. PURPOSE:

To calculate heat required to increase temperature of Site 4 NWIRP Bethpage soils to facilitate free product recovery. Characteristics include the total mass of unsaturated and saturated soils to be heated, total heat required to heat site soils, rate of heat loss due to groundwater flow, and rate of heat application to site soils.

2. APPROACH:

Existing data show intervals of varying contamination levels, as seen in Figures 2-2 to 2-4. For these calculations, the top 20 feet of soils were ignored because they contained limited contamination. Soils were then split by area into unsaturated and saturated and used to calculate the total mass of soil to be heated. These masses were then used to calculate the total heat required to raise soil temperature from 50 to 100 degrees Fahrenheit, and the time it would take to heat site soils and maintain the 100 degree temperature. For saturated soils, groundwater flow was calculated to estimate heat loss over time.

3. DATA INTERVALS:

20 - 50 feet below ground surface (bgs):

Soil at this depth is located above the water table.

50 - 70 feet bgs:

Soil at this depth is located below the water table and is considered saturated. Heat loss due to groundwater flow is considered for this depth interval.

4. ASSUMPTIONS:

The following values will be used as constant values or conversion factors in the calculations:

Average soil density of sandy soils:	1,800 Kg/m ³		
Typical soil porosity sandy soils:	25 %	OR	0.25
Soil density of saturated sandy soils:	2,050 Kg/m ³		
1 m ³	=	35.3198 ft ³	
1 Kg	=	2.2046 lbm	
2,000 pounds	=	1 ton	
C _{p, unsaturated sandy soil}	=	0.191 BTU/lbm*F	
C _{p, saturated sandy soil}	=	0.23 BTU/lbm*F	
C _{p, water at 50°F}	=	1 BTU/lbm*F	
Kh	=	55 ft/day	
gradient	=	0.001 ft/ft	
water density	=	62.4 lbm/ft ³	

References:

Watts, Richard J. Hazardous Wastes: Sources, Pathways, and Receptors. Page 264.
 Kaminski, Jensen. Introduction to Thermals and Fluids Engineering, 2005.

Tetra Tech, Inc.		STANDARD CALCULATION SHEET	
CLIENT:	FILE No:	BY: SK	PAGE: 2 of 4
SUBJECT: Alternative 3 Steam Injection Heat Requirements NWIRP Bethpage Site 4 FS		CHECKED BY: DB	DATE: 7/10/2012

5. CALCULATE TOTAL MASS OF SOIL TO BE HEATED:

Total mass of unsaturated soil to be heated:
Area width: 80 ft
Area length: 100 ft
Total Area 8,000 ft²
Contaminant Thickness: 30 ft
Volume contaminated soil: 240,000 ft³
Volume X Soil Density (unsaturated)
Mass of unsaturated soil = 27,000,000 lbm
Total mass of saturated soil to be heated:
Area width: 80 ft
Area length: 100 ft
Total Area 8,000 ft²
Contaminant Thickness: 20 ft
Volume contaminated soil: 160,000 ft³
Volume X Soil Density (saturated)
Mass of saturated soil = 18,000,000 lbm

6. CALCULATE TOTAL HEAT REQUIRED TO HEAT SOILS FROM 50 TO 100 DEGREES FAHRENHEIT:

Total heat required for unsaturated soil:
 $C_{p, \text{unsaturated sandy soil}} = \Delta Q/m\Delta T$
 $C_{p, \text{unsaturated sandy soil}} = 0.191 \text{ BTU/lbm}^{\circ}\text{F}$
mass unsaturated soil = 27,000,000 lbm
 $\Delta T = 50 \text{ degrees}$
 $\Delta Q = 260,000,000 \text{ BTU}$

Total heat required for saturated soil:
 $C_{p, \text{saturated sandy soil}} = \Delta Q/m\Delta T$
 $C_{p, \text{saturated sandy soil}} = 0.23 \text{ BTU/lbm}^{\circ}\text{F}$
mass saturated soil = 18,000,000 lbm
 $\Delta T = 50 \text{ degrees}$
 $\Delta Q = 210,000,000 \text{ BTU}$

Total heat required:
 $\Delta Q = 470,000,000 \text{ BTU}$

Estimate time required to heat soils to size heater unit: 12 months
= 8,640 hours
BTU/hr = 50,000

Tetra Tech, Inc.		STANDARD CALCULATION SHEET	
CLIENT:	FILE No:	BY: SK	PAGE: 3 of 4
SUBJECT: Alternative 3 Steam Injection Heat Requirements NWIRP Bethpage Site 4 FS		CHECKED BY: DB	DATE: 7/10/2012

7. CALCULATE HEAT LOSS DUE TO GROUNDWATER FLOW:

Groundwater Flow:

Area width:		80 ft
Contaminant Thickness:		20 ft
Area:		1,600 ft ²
Kh	=	55 ft/day
gradient	=	0.001 ft/ft
water density	=	62.4 lbm/ft ³
mass flow (m)	=	5,500 lb/day

Rate of heat loss due to groundwater flow:

Q	=	$C_{p, \text{water at } 50^{\circ}\text{F}} \times m \times \Delta T$
$C_{p, \text{water at } 50^{\circ}\text{F}}$	=	1 BTU/lbm*F
mass flow (m)	=	5,500 lb/day
ΔT	=	50 degrees
Q	=	275,000 BTU/day
Q	=	11,500 BTU/hr

Tetra Tech, Inc.		STANDARD CALCULATION SHEET	
CLIENT:	FILE No:	BY: SK	PAGE: 4 of 4
SUBJECT: Alternative 3 Steam Injection Energy Requirements and Steam Generation NWIRP Bethpage Site 4 FS		CHECKED BY: DB	DATE: 8/1/2012

8. CALCULATE STEAM OUTPUT IN POUNDS PER HOUR

Assumptions and/or conversion factors:

Saturated Steam		Saturated Liquid	
P=	30 lb/in ²	P=	0.95 lb/in ²
T=	250 °F	T=	100 °F

$$Q = m(h_2 - h_1) = m (h_g - h_L)$$

$$Q = 50,000 \text{ BTU/hr (from required heat calculation)}$$

$$50,000 = m(h_g - h_L)$$

$$h_L (100^\circ\text{F, saturated liquid, 0.95 psi})^{(1)} = 68.05 \text{ BTU/lbm}$$

$$h_g (250^\circ\text{F, saturated steam, 30 psi})^{(1)} = 1,164.2 \text{ BTU/lbm}$$

⁽¹⁾ Kaminski, Jensen. Introduction to Thermals and Fluids Engineering, 2005.

$$m = 46 \text{ lb steam/hr}$$

9. ESTIMATE ENERGY REQUIREMENT IN KILOWATTS

$$Q = 50,000 \text{ BTU/hr (from required heat calculation)}$$

*Assume operation is 24 hours per day, for 1 year, or 8,640 hours of operation.

$$1 \text{ KW} = 3,412 \text{ BTU/hr}$$

$$\text{Energy (KW)} = 15 \text{ KW}$$

10. ESTIMATE COST OF ELECTRIC CONSUMPTION

*Assume operation is 24 hours per day, for 1 year, or 8,640 hours of operation.

$$\text{Cost per kilowatt hour}^{(1)}: 0.144 \text{ \$/KW hr}$$

⁽¹⁾ Value from April 2012 value for electricity cost for New York State. [Http://www.eia.gov](http://www.eia.gov).

$$\text{Cost} = \text{KW} \times \text{hours of operation/year} \times \text{Cost per kilowatt hour}$$

$$\text{Cost} = 19,000 \text{ dollars/year}$$

11. ESTIMATE WATER CONSUMPTION:

$$\text{Water Used} = \text{Blower Horsepower (BHP)} \times 4.2 \text{ gallons/hour}$$

*From 100,000 BTU/hr unit specs (Reimers Electra Steam Package Specifications, see attached): 2 BHP

$$\text{Water Used} = 8.4 \text{ gallons/hour}$$

*Assume this amount will also be needed for blowdown, so double the value:

$$\text{Total Water Used} = 17 \text{ gallons/hour}$$

CLIENT:	FILE No:	BY: SK	PAGE: 1 of 1
SUBJECT: Alternative 3 Steam Injection Pipe Sizing, NWIRP BETHPAGE, NEW YORK		CHECKED BY:	DATE: 8/1/2012

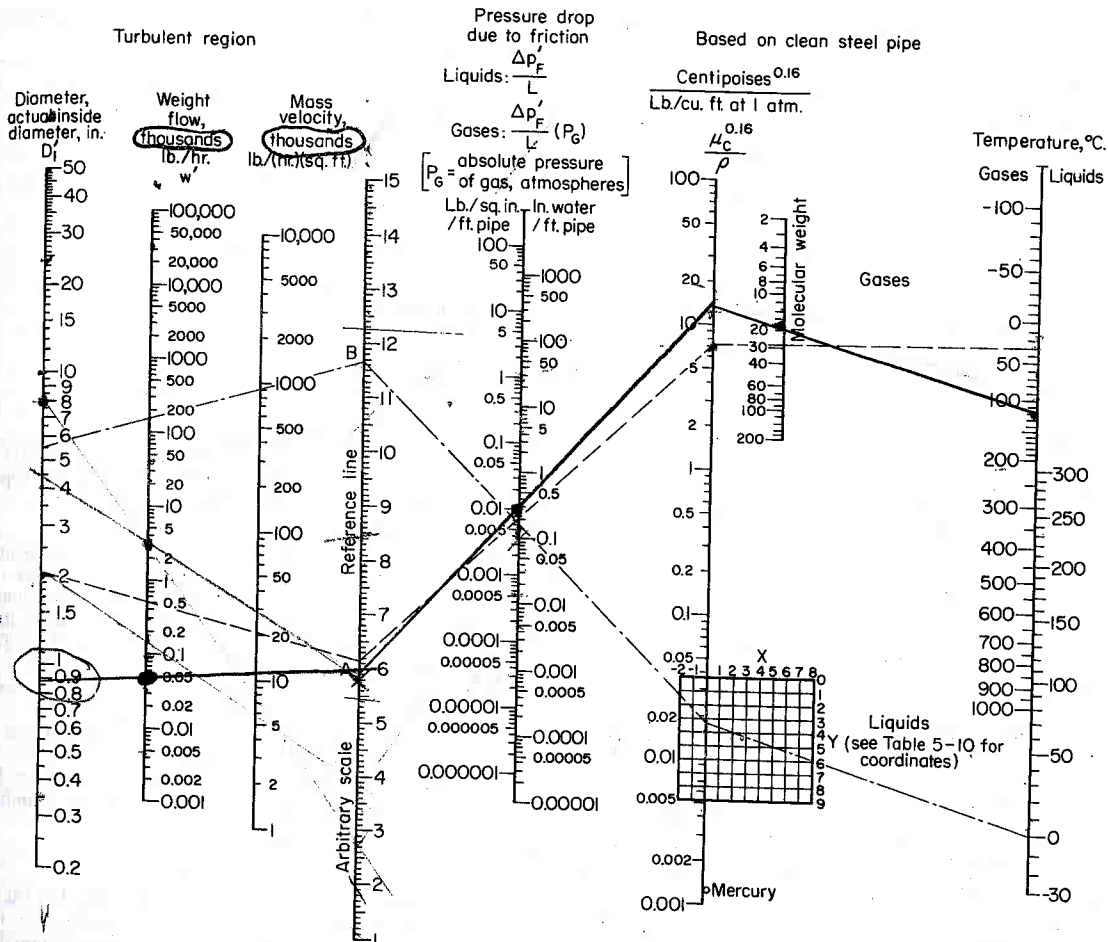

Fig. 5-27. Pipe-flow chart. [Genereaux, Chem. Met. Eng., 44, 241 (1937).]

T °C, gas (steam @ 250 °F) = 121 °C
 Molecular weight (steam) = 18.02

$$\frac{\mu_c^{0.16}}{\rho} = \frac{0.012^{0.16}}{0.0368} = 13.4$$

$$\rho \text{ (steam, 212 °F)} = 0.0368 \frac{\text{lbm}}{\text{ft}^3}$$

$$\mu = 0.808 \times 10^{-5} \frac{\text{lbm}}{\text{ft} \cdot \text{s}}$$

$$1 \text{ centipoise} = 0.001 \frac{\text{N} \cdot \text{s}}{\text{m}^2}$$

$$= 0.808 \times 10^{-5} \frac{\text{lbm}}{\text{ft} \cdot \text{s}} \times \frac{3,600 \text{ s}}{\text{h}}$$

$$1 \frac{\text{N} \cdot \text{s}}{\text{m}^2} = 2419.1 \frac{\text{lbm}}{\text{ft} \cdot \text{h}}$$

$$\mu_c = 0.029088 \frac{\text{lbm}}{\text{ft} \cdot \text{h}} = 1.2 \times 10^{-5} \frac{\text{N} \cdot \text{s}}{\text{m}^2} = 0.0262 \text{ cent.}$$

Weight flow, steam = 46.2 lb/hr

Pressure drop due to friction:

$$\frac{\Delta P_F}{L} (P_G) = \text{Assume } \frac{1 \text{ psi}}{70 \text{ ft pipe}} = 0.01$$

Pipe Diameter ≈ 0.9 in or 1"

From: RogerLBurkhart <Rburkhart@reimersinc.com>
Sent: Tuesday, July 17, 2012 2:32 PM
To:
Subject: Reimers Model #RBHC30E3F
Attachments: RB_Brochure.pdf

Our Model #RBHC30E3F will provide 30 KW (90+ lbs/hr saturated steam/100,000 btu/hr) on 240V/3P. Set pressure up to 85 psig with 100 psig safety valve. Includes pump & condensate return tank. \$5,870.00 F.O.B. Clear Brook, VA

Allow three working days for shipment after receipt of order.

Note this similar model is used to get equipment price estimate. Actual model will be

Reimers Boilers are Designed & constructed to
Section I, Parts PMB & PEB of the A.S.M.E. Boiler Code;
inspected/registered by a commissioned National Board Boiler Inspector;
cULus listed to U.L. Standard #834;
& compliant with A.S.M.E. CSD-1 (Controls Safety Devices).

#RBHC30M3A.
A 15psi safety valve will be used, and a maximum of 600 Volts will be used.

Roger L. Burkhart, President

REIMERS ELECTRA STEAM, INC.
4407 Martinsburg Pike; P.O. Box 37
Clear Brook, VA 22624 U.S.A.
PH: 540-662-3811 FAX: 540-665-8101
Rburkhart@reimersinc.com

A safety factor of approximately 25% was applied to cost, so a cost of \$7,500 will be used for the equipment price estimate.

QUESTION: Where is this boiler to be installed?

Sincerely,
Roger

On Jul 17, 2012, at 2:15 PM, wrote:

I am interested in a steam generator that will produce 50,000 BTU/HR for an environmental remediation project. I think that model RBHC30E3F will suffice.

RB10 – RB30 Steam Boiler Series

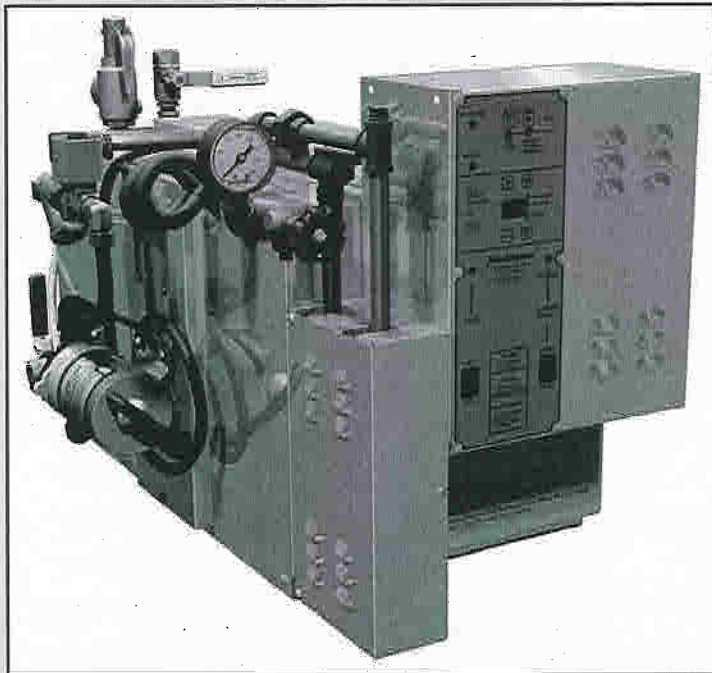

Features

- Miniature boiler max. vessel volume 1.5ft³
- Maximum safety valve setting 100psi
- All boilers are manufactured in accordance with the requirements of the A.S.M.E. Boiler and Pressure Vessel Code and A.S.M.E. CSD-1. Each boiler bears the National Board Stamp "M".
- High quality saturated steam, operating pressure range 0 – 85psig
- Very compact design, all controls accessible from boiler front, very suitable for installation in tight spaces such as autoclaves
- Heavy duty carbon steel pressure vessel. Vessel jacket and electrical enclosure 304 stainless steel
- Large selection of optional equipment

Applications

- Autoclaves
- Air Humidification
- Steam Cleaning
- Dry cleaning
- Food service
- Laboratories

Standard equipment of each boiler includes: Low water cutoff control with manual reset, high pressure cutoff control with manual reset, one (1) operating pressure control, high water cut-off control with automatic or manual reset, pressure gauge and safety valve.

HEATING POWER kW	STEAM CAPACITY lbs/hr (kg/hr)	BHP	VOLTAGE ⁽¹⁾	PHASE	SHIP WT. ⁽³⁾ lbs (kg)	OP. PRESS. RANGE psi (bar)	Steam Outlet (NPT)	
							LP	HP
10 KW	34 (15.4)	1.0	208/240/380/415/480/600	3 ⁽²⁾	179 (81.1)	0 - 85 (0 - 5.86)	½"	½"
18 KW	61 (27.6)	1.8	208/240/380/415/480/600	3 ⁽²⁾	179 (81.1)	0 - 85 (0 - 5.86)	½"	½"
20 KW	69 (31.2)	2.0	208/240/380/415/480/600	3 ⁽²⁾	179 (81.1)	0 - 85 (0 - 5.86)	½"	½"
30 KW	104 (47.1)	3.0	208/240/380/415/480/600	3 ⁽²⁾	179 (81.1)	0 - 85 (0 - 5.86)	½"	½"

⁽¹⁾ Each boiler model requires two (2) power supplies: Primary heating power and secondary control voltage.

Nominal control voltage is 120V, 50/60Hz. When boiler is equipped with transformer option, only heating power supply is required

⁽²⁾ Also available in 240V 1PH

⁽³⁾ On boilers equipped with condensate tanks, add 60lbs (27.2kg) to the shipping weight

Model Number Key

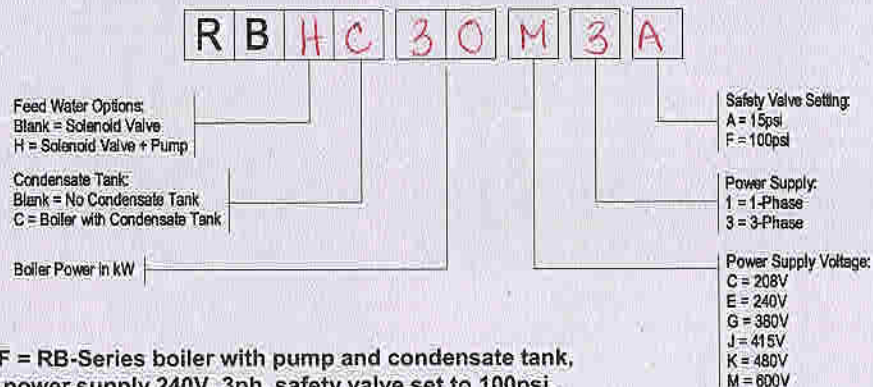

Example: RBHC20E3F = RB-Series boiler with pump and condensate tank, 20kW heating power, power supply 240V, 3ph, safety valve set to 100psi.

Electrical Specifications

HEATING POWER	VOLTAGE	PHASE	AMP DRAW	MIN REQUIRED N.E.C. SERVICE	INTERNAL POWER FUSING	NUMBER & SIZES OF CONTACTORS	NUMBER & SIZE OF ELEMENTS	ELEMENT STRAPING	GAGE OF POWER ENTRY WIRE
KW	V		A	A					AWG (mm ²)
10	208	3	27.8	35.0	NO	1 x 50A res.	1 x 10kW, 208V	Δ	8 (8.35)
18	208	3	50.0	62.0	NO	1 x 75A, res.	2 x 9kW, 208V	Δ	6 (13.3)
20	208	3	55.5	70.0	NO	1 x 75A, res.	2 x 10kW, 208V	Δ	4
30	208	3	83.3	104.0	NO	2 x 50A res.	2 x 15kW, 208V	Δ	2
10	240	1	41.7	52.0	NO	1 x 50A res.	1 x 10kW, 240V	3P	6 (13.3)
18	240	1	75.0	94.0	NO	2 X 50A, res.	2 x 9kW, 240V	3 X 2 rods parallel	3
20	240	1	83.3	104.0	NO	2 X 50A, res.	2 x 10kW, 240V	3 X 2 rods parallel	2
30	240	1	125.0	156.0	6 X 50A, 300V	2 X 50A, res.	2 x 15kW, 240V	3 X 2 rods parallel	2/0
10	240	3	24.1	30.0	NO	1 x 50A res.	1 x 10kW, 240V	Δ	10
18	240	3	43.3	54.0	NO	1 x 50A res.	2 x 9kW, 240V	Δ	6 (13.3)
20	240	3	48.1	60.0	NO	1 x 75A, res.	2 x 10kW, 240V	Δ	6 (13.3)
30	240	3	72.2	90.0	NO	1 x 75A, res.	2 x 15kW, 240V	Δ	3
10	380	3	14.4	18.0	NO	1 x 50A res.	1 x 15kW, 480V	Y	12
20	380	3	31.9	40.0	NO	1 x 50A res.	1 x 10kW, 240V + 1 x 15kW, 240V	Y	8 (8.35)
30	380	3	45.6	57.0	NO	1 x 75A, res.	2 x 15kW, 380V	Y	6 (13.3)
10	415	3	13.9	17.0	NO	1 x 50A res.	1 x 10kW, 415V	Y	12
20	415	3	27.8	35.0	NO	1 x 50A res.	2 x 10kW, 415V	Y	8
30	415	3	41.7	52.0	NO	1 x 50A res.	2 x 15kW, 415V	Y	6 (13.3)
10	480	3	12.0	15.0	NO	1 x 50A res.	1 x 10kW, 480V	Y	12
18	480	3	21.7	27.0	NO	1 x 50A res.	2 x 9kW, 480V	Δ	10
20	480	3	24.1	30.0	NO	1 x 50A res.	2 x 10kW, 480V	Y	8 (8.35)
30	480	3	36.1	45.0	NO	1 x 50A res.	2 x 15kW, 480V	Y	8 (8.35)
10.4	600	3	10.0	13.0	NO	1 x 50A res.	2 x 10kW, 240V	Double Y	14
17.9	600	3	17.2	22.0	NO	1 x 50A res.	1 x 15kW, 208V + 1 x 15kW, 240V	Double Y	10
20.8	600	3	20.0	25.0	NO	1 x 50A res.	2 x 15kW, 208V	Double Y	10
25	600	3	24.1	30.0	NO	1 x 50A res.	1 x 15kW, 240V + 1 x 10kW, 240V	Y-Δ	8 (8.35)

Construction

<p>PRESSURE GAUGE</p> <p>ELECTRONIC BOILER CONTROLLER</p> <p>ALL CONTROLS AND INDICATORS ARE ACCESSIBLE FROM THE FRONT OF THE BOILER:</p> <p>PRESSURE CONTROLS</p> <p>INCOLOY[®] SHEATH HEATING ELEMENTS WITH 2.5" X 2.5" SQUARE FLANGES</p>		<p>SAFETY RELIEF VALVE</p> <p>STEAM OUTLET BALL VALVE 1/2"</p> <p>WATER LEVEL PROBES: - LOW WATER CUTOFF - AUTOMATIC REFILL - HIGH WATER LEVEL</p> <p>HIGH DENSITY MINERAL WOOL THERMAL INSULATION</p> <p>ALL STAINLESS STEEL CABINET WITH WIRE BRUSH FINISH</p>
---	--	--

Dimensional Drawings

$$= (2.105 + 2.25 + 1) \text{ ft} \times (4 \text{ ft})$$

$$= 6 \text{ ft} \times 4 \text{ ft min.}$$

RB10 – RB30 Models

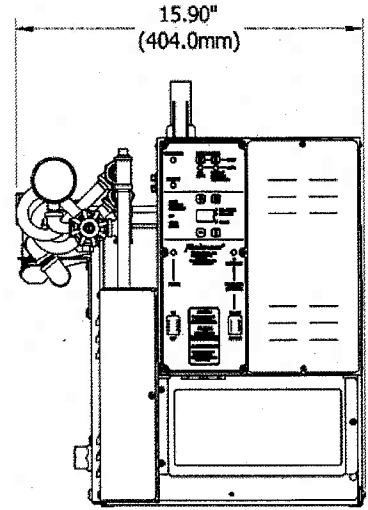
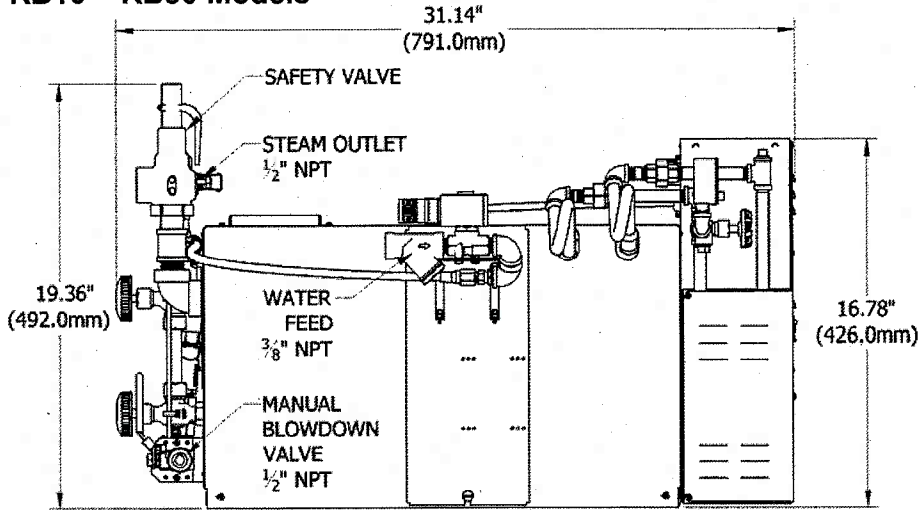

RBH10 – RBH30 Models

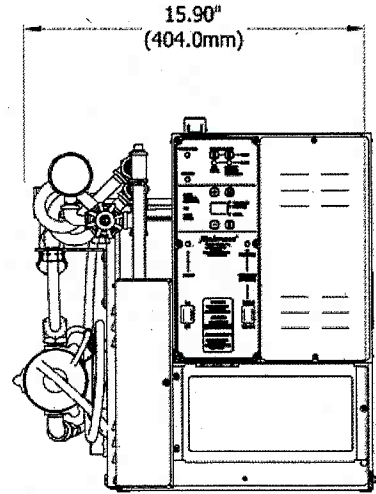
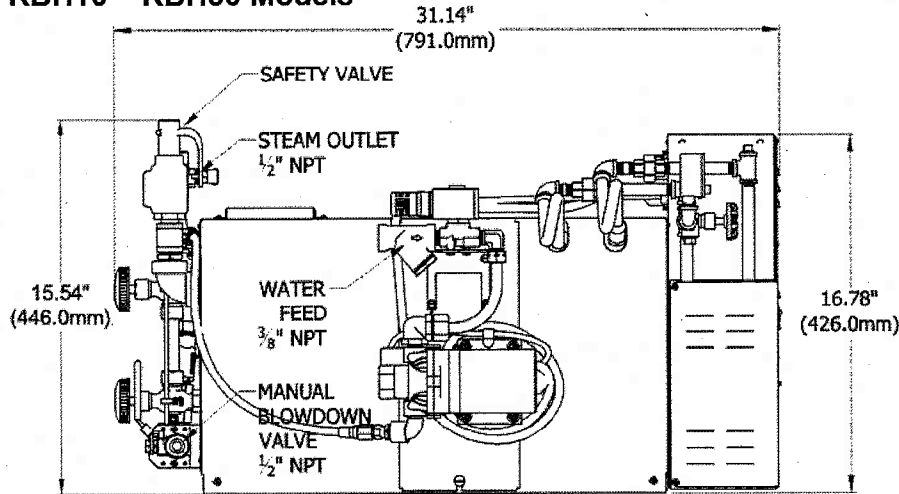

RBHC10 – RBHC30

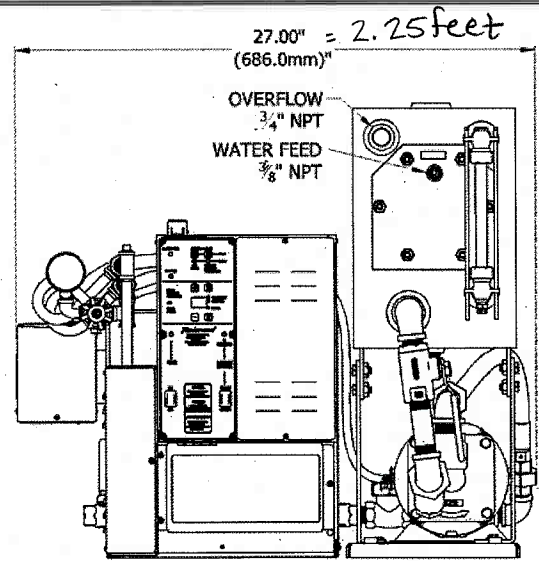
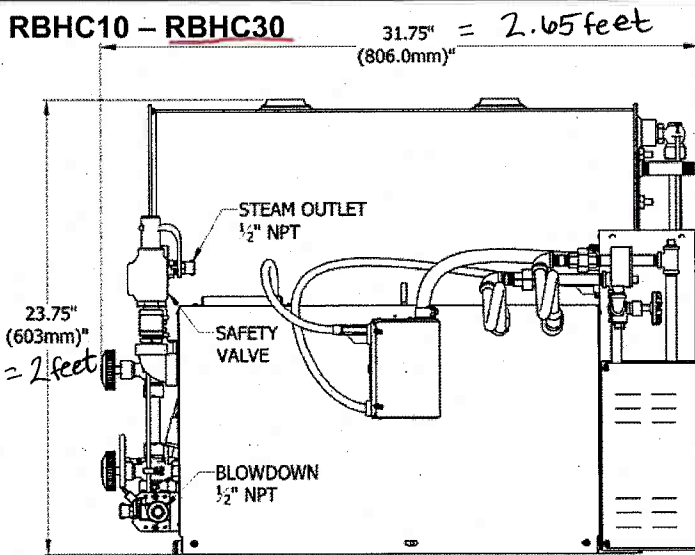

Optional Equipment And Accessories

Pressure Controlled Boiler Blowoff System Automatic Flush & Drain
(Not suitable for 24/7 operation) # OPT1016:

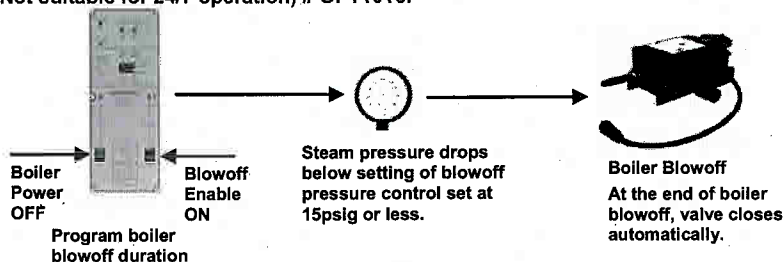

Auxiliary Low Water Cut-Off with McDonnell & Miller Model MM150, # OPTMM150:

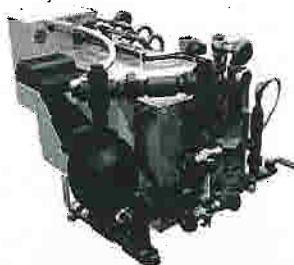

Timer Controlled Boiler Blowoff System (Suitable for 24/7 operation), # OPT1001:

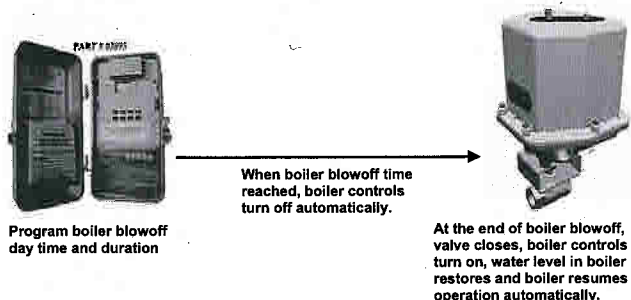

Auxiliary Low Water Cut-Off with Warrick Probe Fitting in External Water Column, # OPT1012

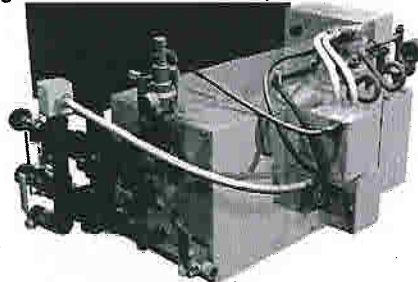

Boiler Blowoff Tank, # BTANK-10:
Boiler blowoff ensures long trouble free boiler operation. The safest means for boiler blowoff is a blowoff tank. Many State and local codes require the use of blowoff tanks.

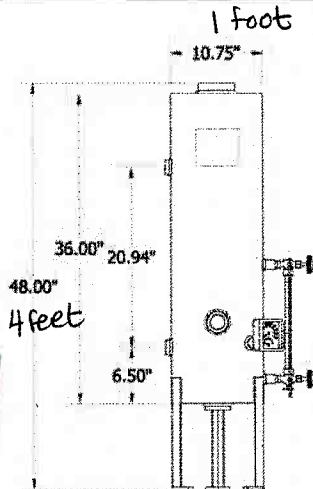
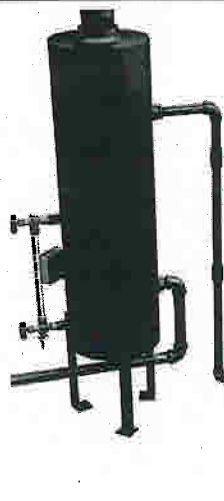

Automatic Boiler ON/OFF, # OPT1017



Program timer to turn boiler ON/OFF automatically

Control Voltage Transformer Options: When using this option, only main power supply is required to operate boiler.

Boiler Voltage	Transformer Option Part Number	
	RB - Series	RBH- and RBHC- Series
208V	OPT1009 - 208	OPT1011- 208RB
240V	OPT1009 - 240	OPT1011- 240RB
380V	OPT1009 - 380	OPT1011- 380RB
415V	OPT1009 - 415	OPT1011- 415RB
480V	OPT1009 - 480	OPT1011- 480RB
600V	OPT1009 - 600	OPT1011- 600RB

Boiler Wheel Set and Steam Wand for Cleaning Applications.



Wheel Set:
OPT1019
Steam Wand:
PART # 20651

Steam Jet Station # 20845

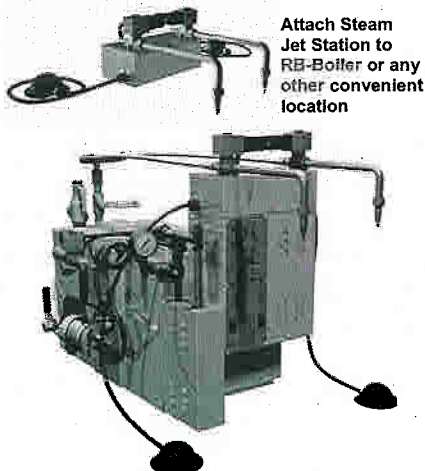

Attach Steam Jet Station to RB-Boiler or any other convenient location

Brass and Bronze Free Boiler Trim, # OPT1030-RB

RB-Steam boiler models fitted with carbon/stainless steel boiler trim for steam generation with very low lead concentrations. Use this option in food service and other applications where lead concentrations are a concern.

Reimers®
Electra Steam, Inc.

P.O. Box 37
4407 Martinsburg Pike
Clear Brook, VA 22624
USA

Phone: 540-662-3811
Fax: 540-665-8101
email: Sales@reimersinc.com
web: www.reimersinc.com

Toll Free: 800-872-7562

[E-mail Us Click Here](#)

[Home](#) | [Contact](#) | [Site Map](#)

Search

[Download Complete Details](#)
[CLICK HERE](#)

- [About Reimers](#)
- [Steam Applications](#)
- [Steam Boilers & Steam Generators](#)
- [New Design JR Boiler](#)
- [Hot Water Boilers](#)
- [Stainless Steel Boilers](#)
- [Industrial & Commercial Boilers](#)
- [Specifications & Dimensions](#)
- [Manuals](#)
- [Repair Center](#)
- [Product Videos](#)
- [Steam Tips: News and Information](#)
- [Frequently Asked Questions](#)
- [Press Release](#)
- [Contact Reimers](#)
- [Home](#)

Specifications and Dimensions

Model RBH30



Click HERE to view RB30 Boiler Overview

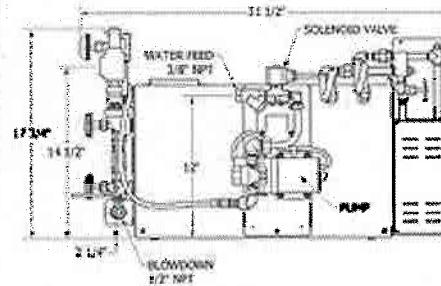
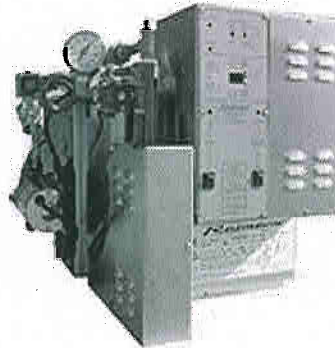

CLICK ON THE DIAGRAM TO ENLARGE

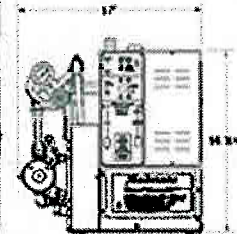

MBTU = 1,000 BTU
MMBTU = 1,000,000 BTU

RB SERIES LOW & HIGH PRESSURE STEAM									
AVAILABLE WITH PUMP AND CONDENSATE TANK									
KW	*# HR	BHP	VOLTAGE	PHASE	SHIP WT.	PSIG	*MBTU/HR	STEAM OUTLET (NPT)	
								LP	HP
10 KW	34	1.0	240/380/415/480	1.3	172	0-85 PSIG	34	3/8	3/8
18 KW	62	1.8	208/240/380/415/480	1.3	172	0-85 PSIG	60	3/8	3/8
20 KW	69	2.0	208/240/380/415/480	1-3	172	0-85 PSIG	60	3/8	3/8
30 KW	104	3.0	208/240/380/415/480	1-3	172	0-85 PSIG	101	3/8	3/8

ALL MODELS AVAILABLE WITH PUMP AND CONDENSATE TANKS

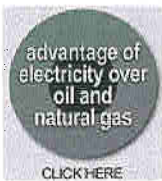

MANUFACTURING

QUALITY STEAM
PRODUCTS FOR 100
YEARS

Reimers 100th
Winchester Star
Article
[CLICK HERE](#)



0

Convenient Location

Place our electric boiler adjacent to the application. Oil or gas fired boilers require a separate boiler room.

Dryer Steam

Our electric boilers provide dry, saturated steam. Oil or gas fired boilers often require long steam lines which result in excessive condensation.

Economical Installation

Electrical wiring is less expensive to run than steam piping. Not having a separate boiler room or vented exhaust saves money.

Safer Operation

Electric boilers are flameless and safer. This eliminates the risk of flareback, firebox explosions and smoke damage.

Quality Excellence

- cULus Listed
- Bears National Board Boiler Stamp
- Built in accordance with ASME code
- A.S.M.E. CSD-1
- C.R.N. Available for Canada

Factory Assurance

- 1 Year Parts Warranty
- Easy Installation
- 3 Day Shipment on RB Models
- Sizes ranging from 10 to 30 KW (1 to 3 BHP)
- USA Voltages (208, 240, 480, 600 Volts)
- Foreign Voltages (220, 380, 415 Volts)

Customer Options

- Condensate return Systems
- Blowdown Systems
- **Stainless Steel Models Available**

Reimers Electra Steam
P.O. Box 37
4407 Martinsburg Pike
Clear Brook, Virginia 22624

Phone: 540-662-3811 · Fax: 540-665-8101
Toll Free: 1-800-872-7562
Fax-Free: 1-800-726-4215
E-mail: sales@reimersinc.com



Can't talk now.
Live Chat

Live chat by LivePerson

[About Reimers](#) | [Steam Applications](#) | [Steam Boilers & Steam Generators](#) | [Hot Water Boilers](#) | [Specifications & Dimensions](#)
[Steam Tips: News and Information](#) | [Stainless Steel Boilers](#) | [Frequently Asked Questions](#) | [Contact Reimers](#) | [Product Videos](#)
[Manuals](#) | [Home](#) | [Site Map](#)

• 14 Injection wells
 * 5 Product Recovery
 outer rectangle: 80' x 100'

Vertical
 horizontal drop = $\frac{\text{foot}}{\text{foot}}$

GW Elevation: ft MSL
 SURVEY TDC - WL (ft below TDC or bgs)
 AS OF 3/31/2011 GW values

CALCULATION OF FLOW GRADIENT (VERIFY)

USE MW11, MW06
 (FLOW SOUTH, SOUTHEAST)

$$72.5 - 72.13 = \frac{0.37 \text{ feet}}{320 \text{ feet}}$$

$$= 0.0011 \frac{\text{foot}}{\text{foot}}$$

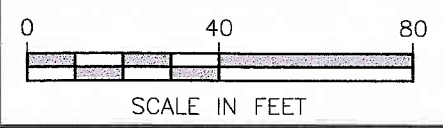

NOTE: mg/kg = MILLIGRAMS PER KILOGRAM

LEGEND

- EXISTING MONITORING WELL LOCATION
- PREVIOUS SOIL BORING LOCATION
- NOVEMBER 2010 SOIL BORING LOCATION
- SOIL CONTAMINATION IN mg/kg.

CALCULATION OF FLOW GRADIENT AERIAL EXTENT OF CONTAMINATION SITE 4 NWRP BETHPAGE, NEW YORK	
FILE 112602751GM01-5	SCALE AS NOTED
FIGURE NUMBER FIGURE B-1	REV 0 DATE 07/16/12

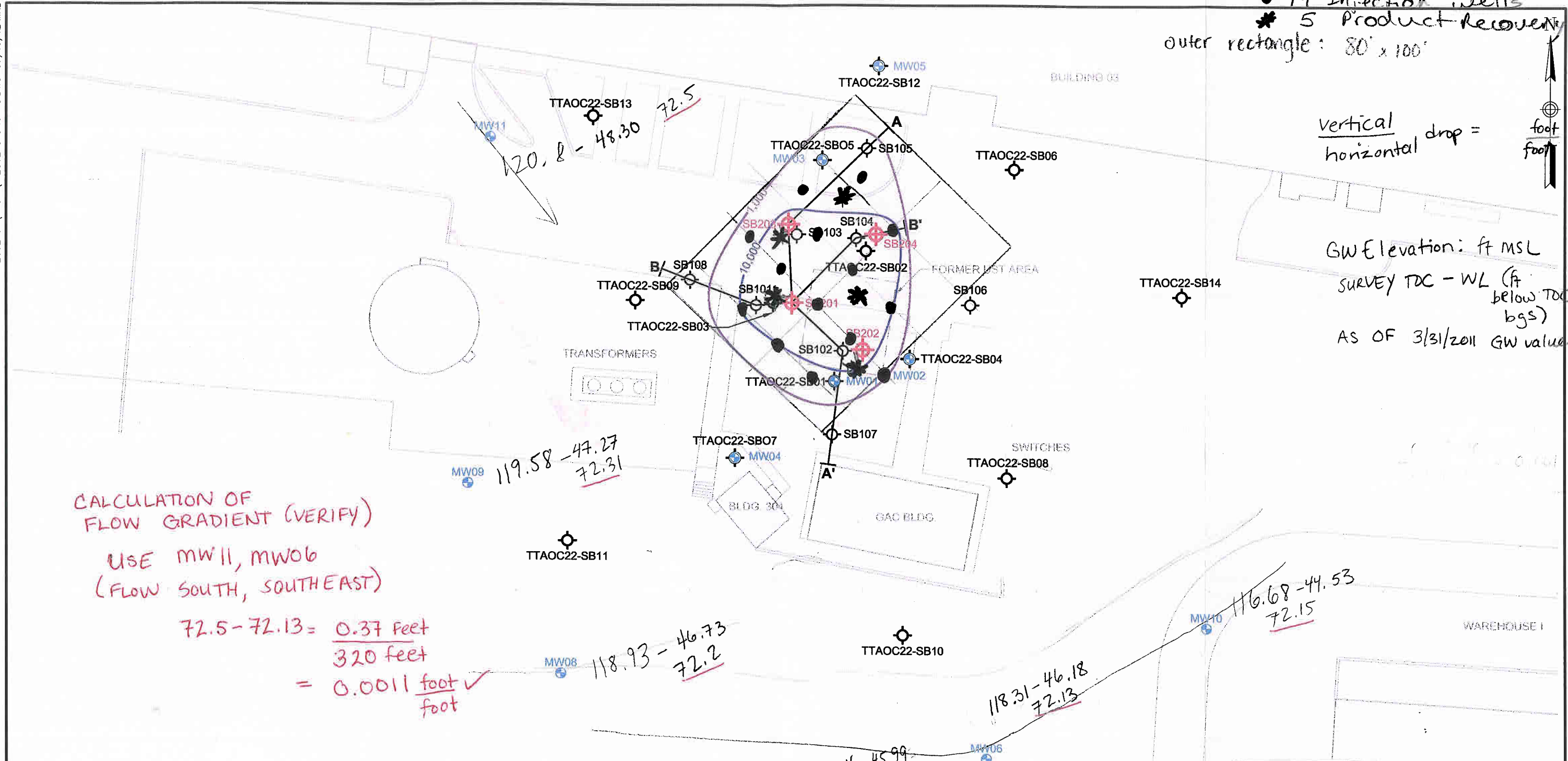

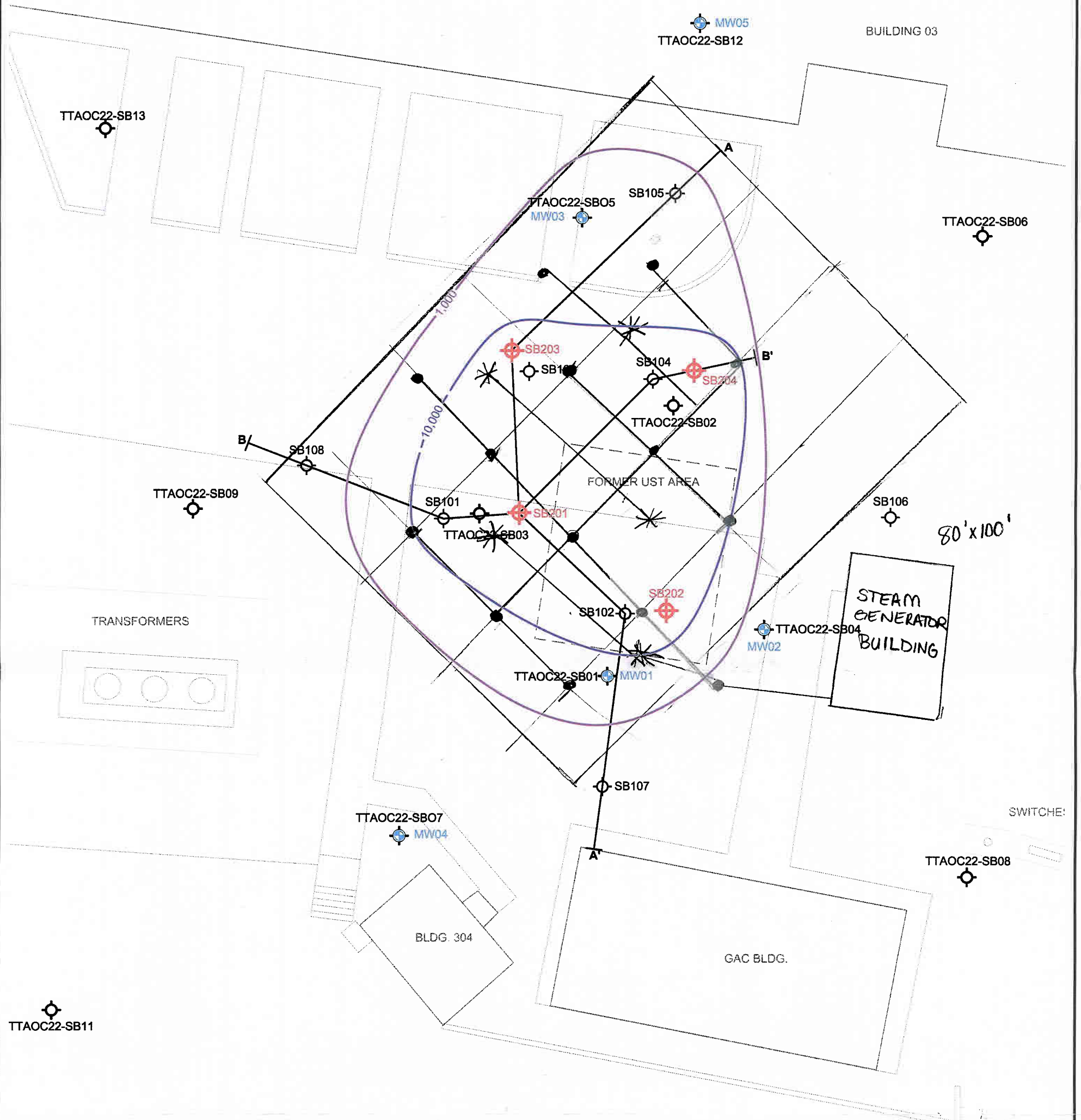

Piping Estimate:
 - Steam Piping: $40 + 80 + 40 + 25 + 70 + 25 = 280'$
 - Free Product Recovery: $20 + 40 + 35 + 50 + 20 = 165'$

• = Steam Injection
 * = Free Product Recovery Well

- LEGEND**
- EXISTING MONITORING WELL LOCATION
 - PREVIOUS SOIL BORING LOCATION
 - NOVEMBER 2010 SOIL BORING LOCATION
 - SOIL CONTAMINATION IN mg/kg.

NOTE: mg/kg = MILLIGRAMS PER KILOGRAM

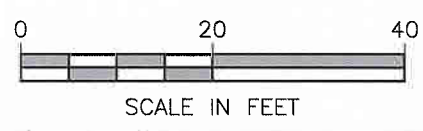

Alternative 3: Steam Injection and Free Product Recovery Well GRID
 SITE 4
 NWRP
 BETHPAGE, NEW YORK

FILE 112G02751GM02	SCALE AS NOTED
FIGURE NUMBER FIGURE B-2	REV DATE 0 07/18/12

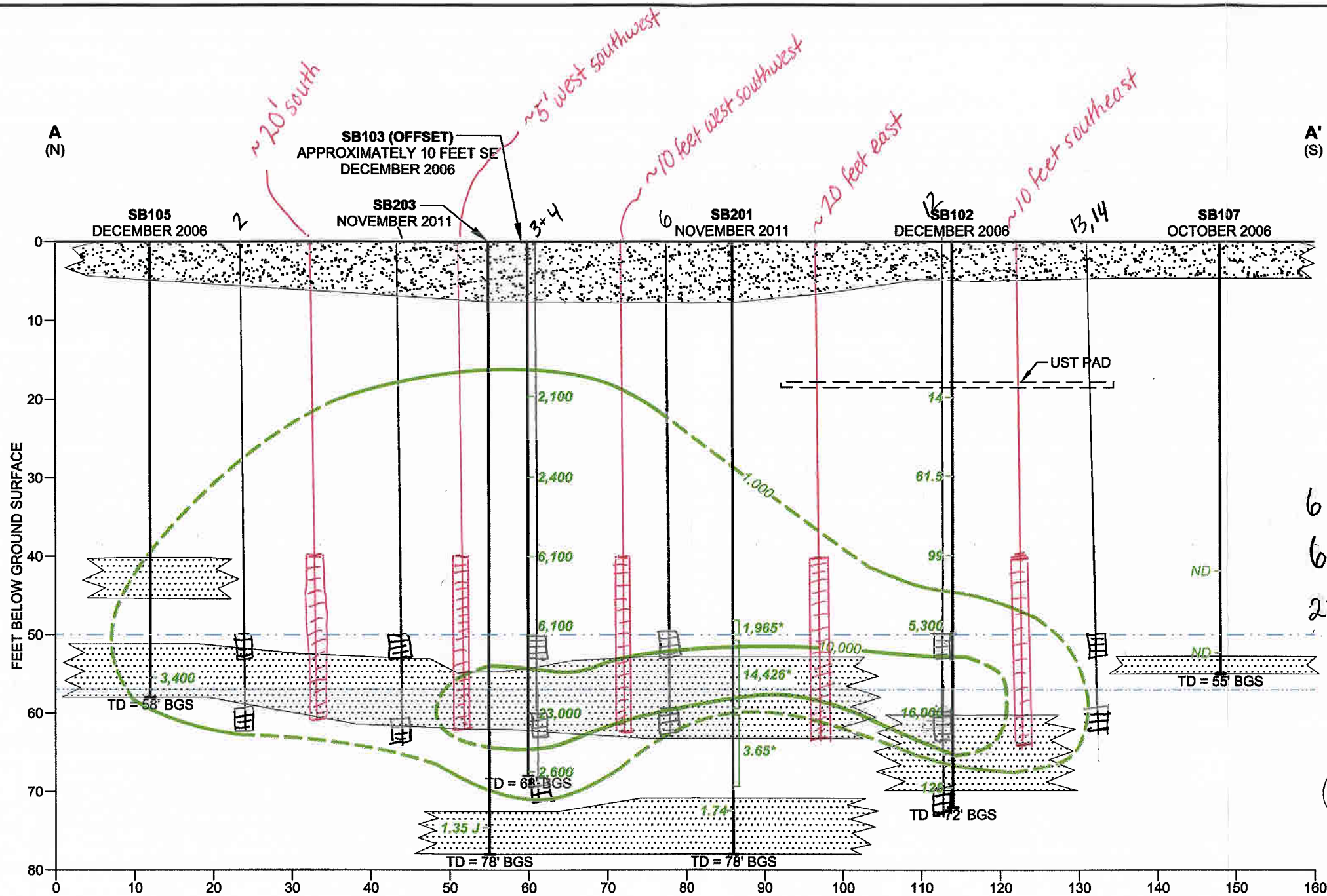

6 @ 50' TDH
 6 @ 60' TDH
 2 @ 70' TDH
 5 @ 40'-60' TDH

Note that some clusters (i.e. 3, 4, 13, 14) overlap on this figure. Clusters may contain 1-3 wells each. Well depths are approximate.

LEGEND

	GRAVEL/ASPHALT		TPH (10,000 mg/kg CONTOUR LINE) (DASHED WHERE INFERRED)
	F-C SAND WITH TRACE CLAY, GRAVEL AND SILT	SB102	SOIL BORING
	SILTY SAND	*	COMPOSITE OF SB201 AND SB204
	1999 WATER TABLE ~57 FEET BGS		TPH RESULT IN mg/kg
	2011 WATER TABLE ~50 FEET BGS	TD = 58' BGS	TOTAL DEPTH (BGS) BELOW GROUND SURFACE
	TPH (1,000 mg/kg CONTOUR LINE) (DASHED WHERE INFERRED)	ND	TPH NOT DETECTED

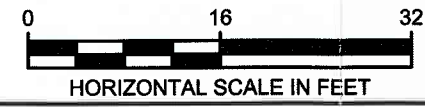

TETRA TECH

Alternative 3: Steam Injection
 3 Free Product Recovery
CROSS SECTION Well GRID
SITE 4
NWIRP
BETHPAGE, NEW YORK

FILE 112G02751GS02	SCALE AS NOTED
FIGURE NUMBER FIGURE B-3	REV DATE 0 08/01/12

112G02751\FS\DR\112G02751GS02.DWG 08/01/12 MKS

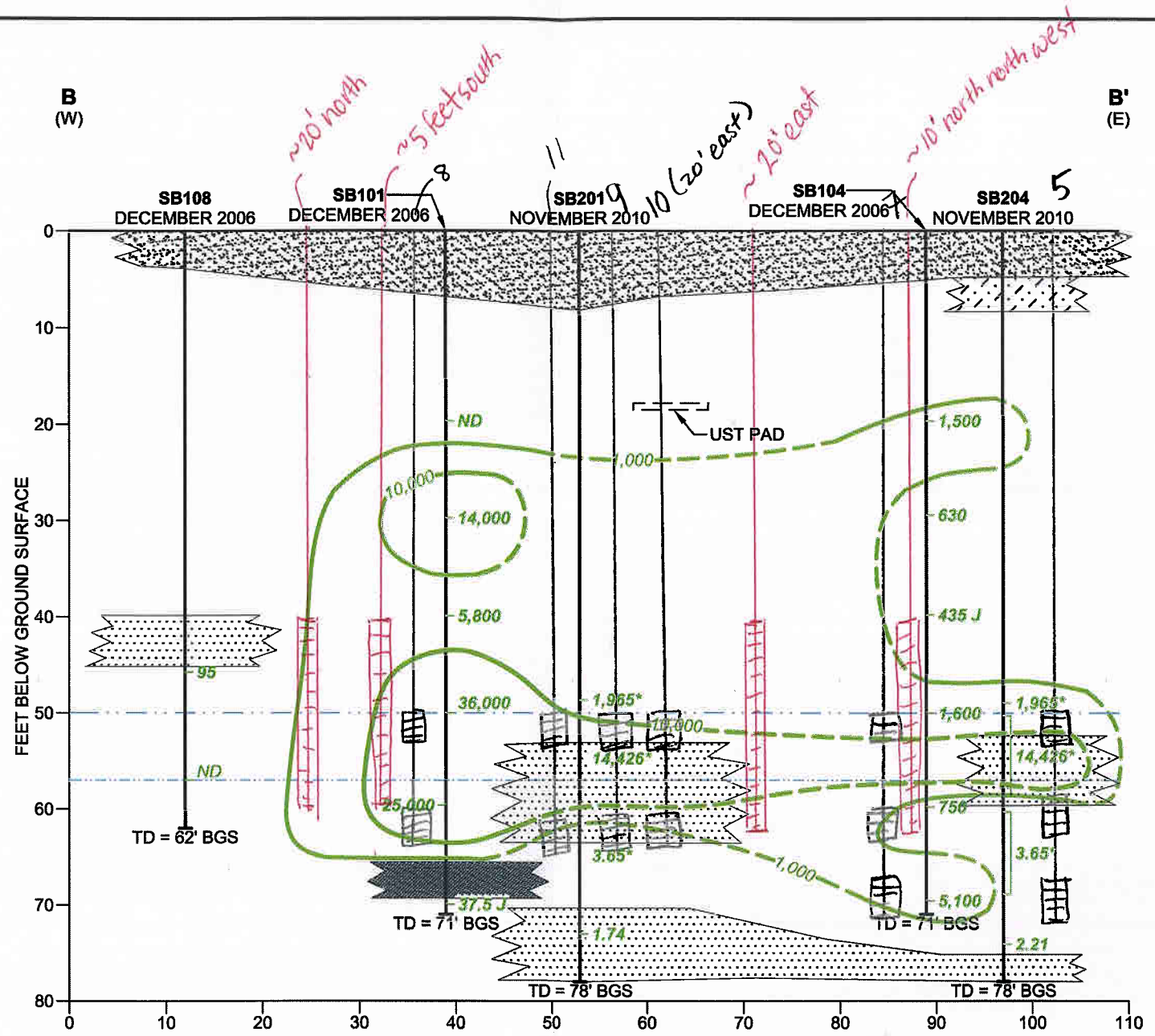

6 @ 50' TDH
 6 @ 60' TDH
 2 @ 70' TDH
 5 @ 40'-60' [1 not on this X-section]

LEGEND

- SAND WITH GRAVEL/ASPHALT/CONCRETE
- F-C SAND WITH TRACE CLAY, GRAVEL AND SILT
- SILTY SAND
- CLAYEY SILT
- CLAYEY SAND
- 1999 WATER TABLE ~57 FEET BGS
- 2011 WATER TABLE ~50 FEET BGS

- 1,000 TPH (1,000 mg/kg CONTOUR LINE) (DASHED WHERE INFERRED)
- 10,000 TPH (10,000 mg/kg CONTOUR LINE) (DASHED WHERE INFERRED)
- SB102 SOIL BORING
- * COMPOSITE OF SB201 AND SB204
- 5,300 TPH RESULT IN mg/kg
- TD = 58' BGS TOTAL DEPTH (BGS) BELOW GROUND SURFACE
- ND TPH NOT DETECTED

C-37

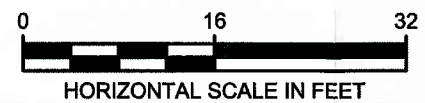

Alternative 3: Steam Injection
 3 Free Product Recovery
 CROSS SECTION Well GRID
 SITE 4
 NWIRP
 BETHPAGE, NEW YORK

FILE 112G02751GS02	SCALE AS NOTED
FIGURE NUMBER FIGURE B-4	REV 0 DATE 08/01/12

Tetra Tech, Inc.		STANDARD CALCULATION SHEET	
CLIENT:	FILE No:	BY: SK	PAGE: 1 of 4
SUBJECT: Alternative 4 Steam Injection Heat Requirements NWIRP Bethpage Site 4 FS		CHECKED BY: DB	DATE: 7/17/2012

1. PURPOSE:

To calculate heat required to increase temperature of Site 4 NWIRP Bethpage soils to facilitate free product recovery. Characteristics include the total mass of unsaturated soils to be heated, total heat required to heat site soils, and rate of heat application to site soils.

2. APPROACH:

Existing data show intervals of varying contamination levels, as seen in Figures 2-2 to 2-4. The top 20 feet of soils were ignored because they contained limited contamination. Soils were then split by area into unsaturated and saturated and used to calculate the total mass of soil to be heated. These masses were then used to calculate the total heat required to raise soil temperature from 50 to 100 degrees Fahrenheit, and the time it would take to heat site soils and maintain the 100 degree temperature. For Alternative 4, saturated soils were not included because the free product recovery system for this alternative was scaled down.

3. DATA INTERVALS:

20 - 50 feet below ground surface (bgs):

Soil at this depth is located above the water table.

4. ASSUMPTIONS:

The following values will be used as constant values or conversion factors in the calculations:

Average soil density of sandy soils:	1,800 Kg/m ³		
Typical soil porosity sandy soils:	25 %	OR	0.25
1 m ³	=	35.3198 ft ³	
1 Kg	=	2.2046 lbm	
2,000 pounds	=	1 ton	
C _{p, unsaturated sandy soil}	=	0.191 BTU/lbm*F	

References:

Watts, Richard J. Hazardous Wastes: Sources, Pathways, and Receptors. Page 264.

Kaminski, Jensen. Introduction to Thermals and Fluids Engineering, 2005.

CLIENT:	FILE No:	BY: SK	PAGE: 2 of 4
SUBJECT: Alternative 4 Steam Injection Heat Requirements NWIRP Bethpage Site 4 FS		CHECKED BY: DB	DATE: 7/17/2012

5. CALCULATE TOTAL MASS OF SOIL TO BE HEATED:

Total mass of unsaturated soil to be heated:
 Area width: 80 ft
 Area length: 100 ft
 Total Area 8,000 ft²
 Contaminant Thickness: 30 ft
 Volume contaminated soil: 240,000 ft³
 Volume X Soil Density (unsaturated)
Mass of unsaturated soil = 27,000,000 lbm

6. CALCULATE TOTAL HEAT REQUIRED TO HEAT SOILS FROM 50 TO 100 DEGREES FAHRENHEIT:

Total heat required for unsaturated soil:

$C_{p, \text{unsaturated sandy soil}}$	=	$\Delta Q/m\Delta T$
$C_{p, \text{unsaturated sandy soil}}$	=	0.191 BTU/lbm*F
mass unsaturated soil	=	27,000,000 lbm
ΔT	=	50 degrees
ΔQ	=	260,000,000 BTU

Estimate time required to heat soils to size heater unit: 12 months
 = 8,640 hours
BTU/hr = 30,000

Tetra Tech, Inc.		STANDARD CALCULATION SHEET	
CLIENT:	FILE No:	BY: SK	PAGE: 3 of 4
SUBJECT: Alternative 4 Steam Injection Energy Requirements and Steam Generation NWIRP Bethpage Site 4 FS		CHECKED BY: DB	DATE: 8/1/2012

7. CALCULATE STEAM OUTPUT IN POUNDS PER HOUR

Assumptions and/or conversion factors:

Saturated Steam		Saturated Liquid	
P=	30 lb/in ²	P=	0.95 lb/in ²
T=	250 °F	T=	100 °F

$$Q = m(h_2 - h_1) = m (h_g - h_L)$$

$$Q = 30,000 \text{ BTU/hr (from required heat calculation)}$$

$$30,000 = m(h_g - h_L)$$

$$h_L (100^\circ\text{F, saturated liquid, 0.95 psi})^{(1)} = 68.05 \text{ BTU/lbm}$$

$$h_g (250^\circ\text{F, saturated steam, 30 psi})^{(1)} = 1,164.2 \text{ BTU/lbm}$$

⁽¹⁾ Kaminski, Jensen. Introduction to Thermals and Fluids Engineering, 2005.

$$m = 27 \text{ lb steam/hr}$$

8. ESTIMATE ENERGY REQUIREMENT IN KILOWATTS

$$Q = 30,000 \text{ BTU/hr (from required heat calculation)}$$

*Assume operation is 24 hours per day, for 1 year, or 8,640 hours of operation.

$$1 \text{ KW} = 3,412 \text{ BTU/hr}$$

$$\text{Energy (KW)} = 9 \text{ KW}$$

9. ESTIMATE COST OF ELECTRIC CONSUMPTION

*Assume operation is 24 hours per day, for 1 year, or 8,640 hours of operation.

$$\text{Cost per kilowatt hour}^{(2)}: 0.144 \text{ \$/KW hr}$$

⁽²⁾ Value from April 2012 value for electricity cost for New York State. [Http://www.eia.gov](http://www.eia.gov).

$$\text{Cost} = \text{KW} \times \text{hours of operation/year} \times \text{Cost per kilowatt hour}$$

$$\text{Cost (Steam Generator)} = 11,000 \text{ dollars/year}$$

$$\text{Total Cost (Blower \& Steam Generator)} = 15,000 \text{ dollars/year}$$

10. ESTIMATE WATER CONSUMPTION:

$$\text{Water Used} = \text{Blower Horsepower (BHP)} \times 4.2 \text{ gallons/hour}$$

*From 100,000 BTU/hr unit specs (Reimers Electra Steam Package Specifications, see attached): 1.8 BHP

$$\text{Water Used} = 7.6 \text{ gallons/hour}$$

*Assume this amount will also be needed for blowdown, so double the value:

$$\text{Total Water Used} = 15 \text{ gallons/hour}$$

11. ESTIMATE FREE PRODUCT RECOVERY:

*Assume that 70% of free product can be removed with combined biosparging, steam injection, and free product removal. See results of the bench scale testing in the Technical Memorandum for Site 4 soils.

$$\text{Free Product Recovery} = 0.7 \times 11,300 \text{ gallons}^{(3)} = 7,900 \text{ gallons}$$

⁽³⁾Value from the Mass Calculations of TPH in gallons. Value is total gallons in >1,000 mg/Kg TPH contour.

Tetra Tech, Inc.		STANDARD CALCULATION SHEET	
CLIENT:	FILE No:	BY: SK	PAGE: 4 of 4
SUBJECT: Alternative 4 Biosparging Design Calculations for Air Compressor Sizing and Electrical Costs NWIRP Bethpage Site 4 FS		CHECKED BY: DB	DATE: 7/17/2012

1. PURPOSE:

To calculate design parameters for the initial design of air sparge systems for Site 4 soils.

2. APPROACH:

Use the number of wells and total dynamic head to calculate pressure, flow, and horsepower required.

3. CALCULATE PARAMETERS FOR VERTICAL AIR SPARGE WELL SYSTEM:

Use the equation for adiabatic blower horsepower (this equation assumes an approximate 70% efficiency):

$$\text{Blower HP} = (0.31)(V_s)[(P_d/P_a)^{0.283} - 1]$$

V_s = inlet acfm

P_d = discharge pressure

P_a = inlet pressure = 14.7 psi

# wells	14	$h =$	P/γ
tdh	70 feet	$\gamma =$	62.4 lb/ft ³
height (h)	20 feet		
Q_{well}	5 cfm ⁽¹⁾		
Q_{total}	70 cfm		
minimum pressure (P)	8.7 psi		
pressure (P)	11 psi ⁽²⁾		
power use (HP)	4 ⁽³⁾		

1 = Typical air flow ranges from 3 to 25 standard cubic feet per minute (cfm) as referenced by the EPA: (October 1994). Chapter 7: Air Sparging. <http://www.epa.gov>. Retrieved July 11, 2012 from http://www.epa.gov/oust/pubs/tum_ch7.pdf.

2 = Pressure is calculated by dividing the height (in feet of water) by the specific weight of water (approximately 1 psi required per every 2.3 feet of hydraulic head). A safety factor of approximately 2 psi is applied.

3 = Horsepower (hp) is calculated by multiplying the theoretical power required to compress one cfm of air by the total cfm to produce the total horsepower required. An atmospheric pressure of 14.7 psi was used as the inlet pressure.

4. ESTIMATE COST OF ELECTRIC CONSUMPTION

Power Requirement From Air Blower = $P(\text{KW}) = \text{HP} * 0.75 \text{ KW/HP} = 3 \text{ KW}$

*1HP = 0.75 KW

*Assume operation is 24 hours per day, for 1 year, or 8,640 hours of operation.

Cost per kilowatt hour⁽⁴⁾: 0.144 \$/KW hr

⁽⁴⁾ Value from April 2012 value for electricity cost for New York State. [Http://www.eia.gov](http://www.eia.gov).

Cost = KW X hours of operation/year X Cost per kilowatt hour

Cost (Blower) = 3,700 dollars/year

Panther WA 3032-3300D

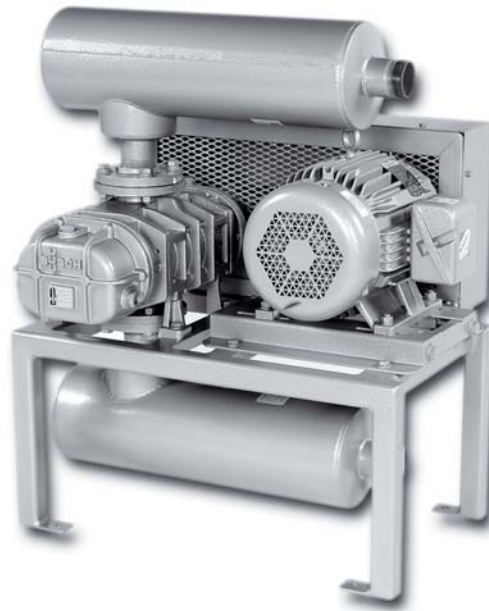

Panther WA 3065 D

Description

The Busch Panther blower is a rotary lobe, positive displacement blower that is designed for either pressure or vacuum applications. Vacuum or pressure is produced by two non-contacting rotors in an oil-free pumping chamber creating a clean, efficient and wear free environment.

Wearing parts, such as bearings and gears, are separated from the

pumping chamber by labyrinth seals yielding a long service life. Heavy duty construction and oil lubricated bearings on both the gear end and drive end of the blower ensure reliable operation.

The Panther blower features a tri-lobe design that increases efficiency and decreases sound levels.

Features

- Low maintenance
- High efficiency
- Tri-lobe design
- Dry, non-contacting pumping chamber
- Oil lubricated bearings on both ends
- Labyrinth seals
- Heavy duty construction

Operating Principle

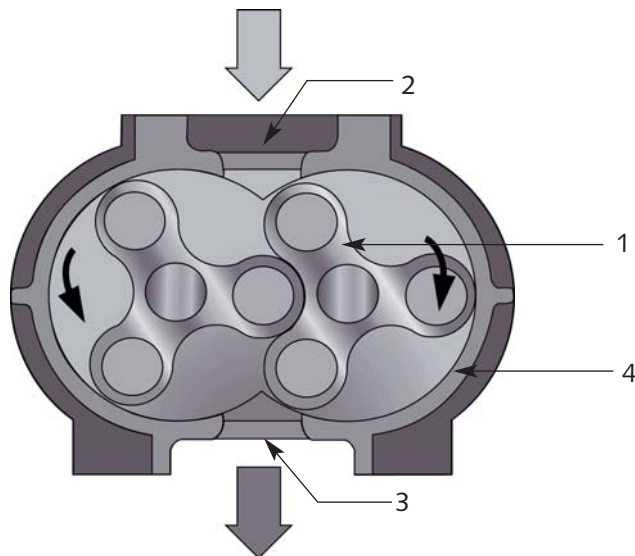

1. Rotor
2. Inlet
3. Outlet
4. Cylinder

Operating Principle

The tri-lobe Panther by Busch, works according to the proven rotary lobe principle. Operation is both simple and effective. Two rotors with identical profiles rotate in opposite directions within a casing. As they rotate, air is drawn into the space between each rotor and the casing where it is trapped, transported and discharged by the rotation. This occurs with each revolution of each rotor and therefore six times for each revolution of the drive shaft. There is no mechanical contact between the rotors and cylinder. Therefore no oil lubrication is required in the pumping chamber.

Standard Equipment

- Rotary lobe blower on base frame
- Discharge silencer
- Inlet side silencer
- Motor mounting assembly incl. V-belt drive
- Motor
- Belt guard

Application

The blower speed and motor size can be selected specifically to suit the exact needs of the following applications:

- Food processing
- Hold down applications
- Lifting and transport systems
- Milking
- Pneumatic conveying
- Soil remediation
- Textile applications
- Waste treatment aeration
- Wood routers



Technical Data

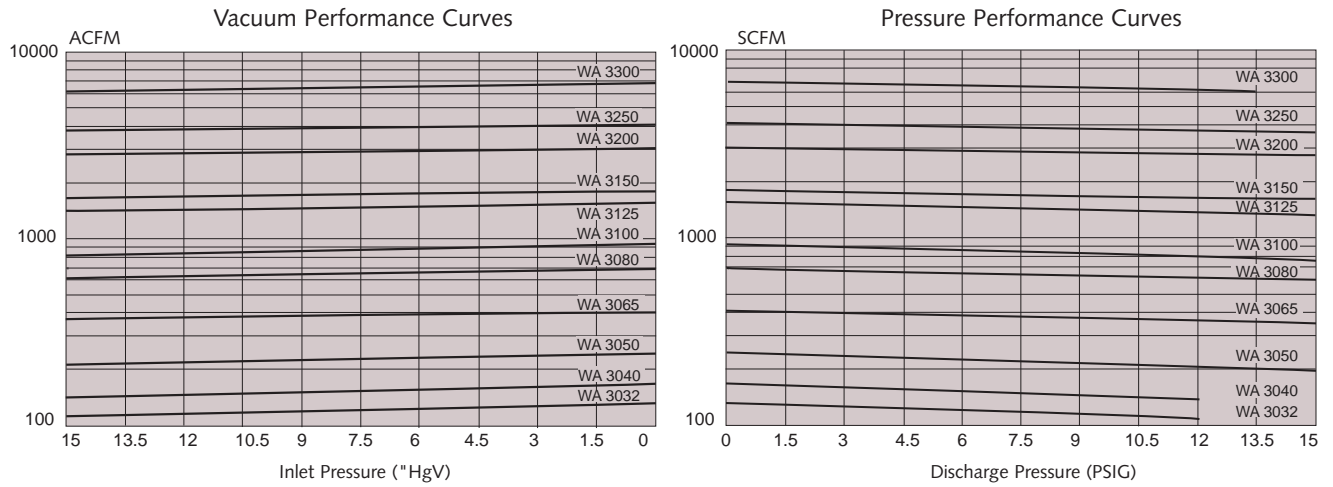

Maximum curve shown (actual capacity depends on motor speed and power selected).

Technical Data		WA 3032 D	WA 3040 D	WA 3050 D	WA 3065 D	WA 3080 D	WA 3100 D
Panther Model							
Nominal pumping speed	CFM	35-131	53-166	57-243	109-407	170-687	205-931
Maximum vacuum	"HgV	15	15	15	15	15	15
Ultimate pressure	PSIG	12	12	15	15	15	15
Motor power range	HP	1-10	1-15	1-25	1-40	3-60	3-75
Blower speed range	RPM	1500-3750	1500-3750	1150-3550	1150-3550	1150-3550	850-3250
Bare shaft blower weight	Lbs	110	121	165	198	330	440

Technical Data		WA 3125 D	WA 3150 D	WA 3200 D	WA 3250 D	WA 3300 D
Panther Model						
Nominal pumping speed	CFM	360-1571	470-1796	604-3030	978-4080	2564-6829
Maximum vacuum	"HgV	15	15	15	15	15
Ultimate pressure	PSIG	15	15	15	15	13.5
Motor power range	HP	5-125	5-150	10-270	15-350	30-450
Blower speed range	RPM	750-2850	750-2550	600-2400	600-2100	600-1500
Bare shaft blower weight	Lbs	858	990	1650	2200	3080

Performance data based on ambient conditions of 14.7 PSIG and 70° F, and have a tolerance of +/- 10%.

Rotary Lobe, Positive Displacement Blower



Dimensions

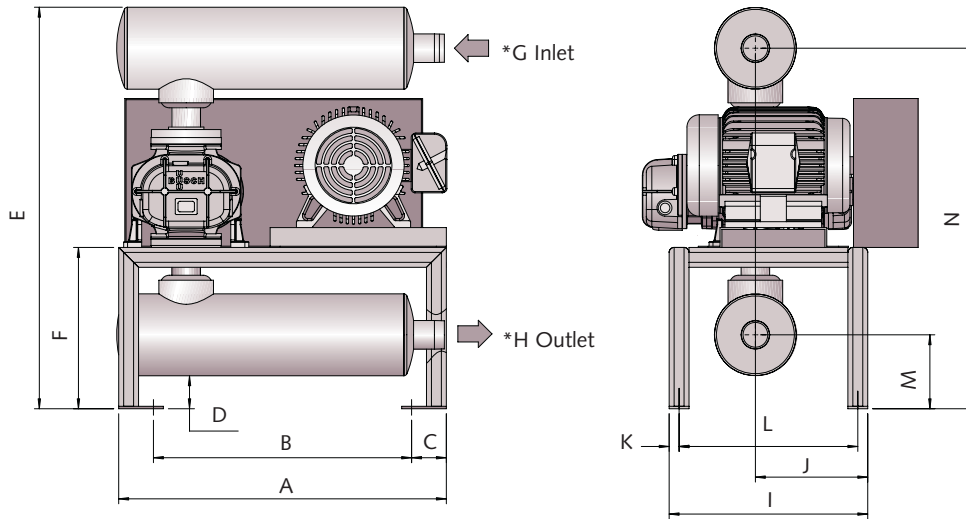

Dimensions	A	B	C	D	E	F	G	H	I	J	K	L	M	N
WA 3050 D	33	26	3 ¹ / ₂	2 ³ / ₄	41	16 ¹ / ₄	2 ¹ / ₂	2 ¹ / ₂	20	10 ¹ / ₄	1	18	6 ⁷ / ₈	36 ⁷ / ₈
WA 3065 D	33	26	3 ¹ / ₂	2 ¹ / ₈	41 ³ / ₄	16 ¹ / ₄	3	3	20	11 ³ / ₈	1	18	6 ¹ / ₄	37 ⁵ / ₈
WA 3080 D	36	29	3 ¹ / ₂	4 ³ / ₄	54 ¹ / ₂	22 ¹ / ₄	4	4	22	12 ³ / ₄	1	20	9 ⁷ / ₈	49 ¹ / ₈
WA 3100 D	42	33	4 ¹ / ₂	5 ⁷ / ₈	55 ³ / ₈	23 ³ / ₈	4	4	28	15 ³ / ₈	1 ¹ / ₂	25	11	50 ¹ / ₄
WA 3125 D	48	39	4 ¹ / ₂	5 ³ / ₈	71	29 ³ / ₈	6	6	32	16 ¹ / ₂	1 ¹ / ₂	29	12 ¹ / ₂	63 ⁷ / ₈

All dimensions in inches unless otherwise noted.
 Dimensions of specific units depend on motor speed and application type selected.
 Dimensions of additional sizes are available by request.
 *3" & smaller is MNPT, 4" & larger is flanged.

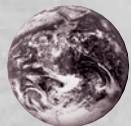

Busch - all over the world in industry

ISO 9001-2000 Registered Company

**Busch LLC 516 Viking Drive Virginia Beach, VA 23452
 Phone (757) 463-7800 FAX (757) 463-7407**

**www.buschusa.com
 1-800-USA-PUMP**

Amsterdam Barcelona Birmingham Basel Brussels Dublin Göteborg Helsinki Istanbul Copenhagen Kuala Lumpur Milan Maulburg Melbourne Montreal Moscow
 New York New Plymouth Oslo Paris San Jose São Paulo Seoul Singapore Taipei Tokyo Vienna
 C-45

12-B1/22-B1

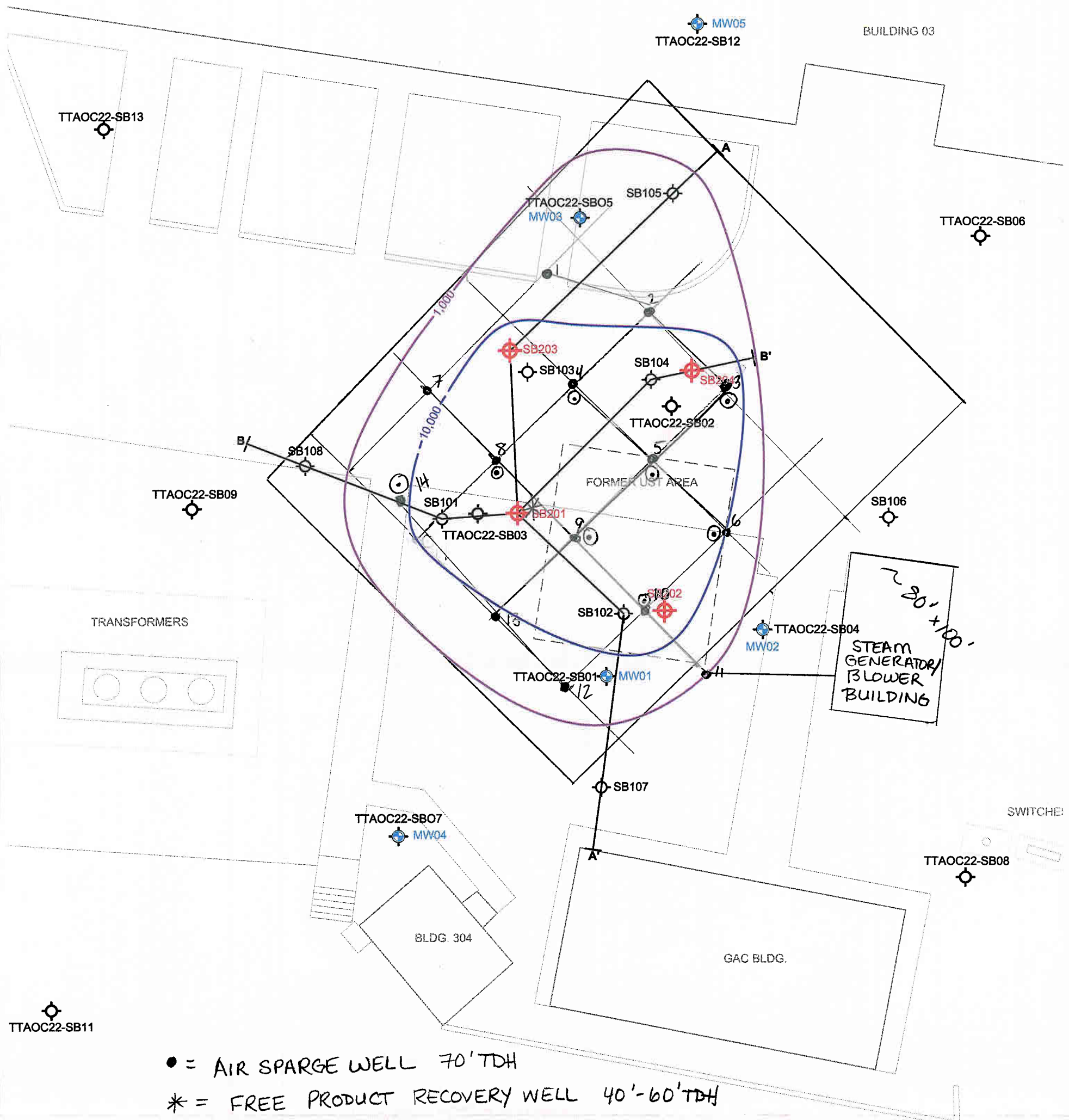

- = AIR SPARGE WELL 70' TDH
- * = FREE PRODUCT RECOVERY WELL 40'-60' TDH
- ⊙ = STEAM INJECTION WELL 50' TDH (>10,000 mg/kg concentration)

Piping Estimate = 527' ±

- DUAL AIR/STEAM INJECTION: $40 + 20 + 40 + 40 + 40 = 180'$
- AIR INJECTION: $180' + 40' + 20' + 20' + 20' = 280'$
- FREE PRODUCT RECOVERY: $5 + 50 + 25 = 80'$

LEGEND

	EXISTING MONITORING WELL LOCATION
	PREVIOUS SOIL BORING LOCATION
	NOVEMBER 2010 SOIL BORING LOCATION
	SOIL CONTAMINATION IN mg/kg.

NOTE: mg/kg = MILLIGRAMS PER KILOGRAM



TETRA TECH	
Alternative 4: BIOSPARGING WITH LIMITED STEAM INJECTION WELL GRID SITE 4 NWRP BETHPAGE, NEW YORK	
FILE: 112G02751GM02	SCALE: AS NOTED
FIGURE NUMBER: FIGURE C-1	REV: 0 DATE: 07/18/12

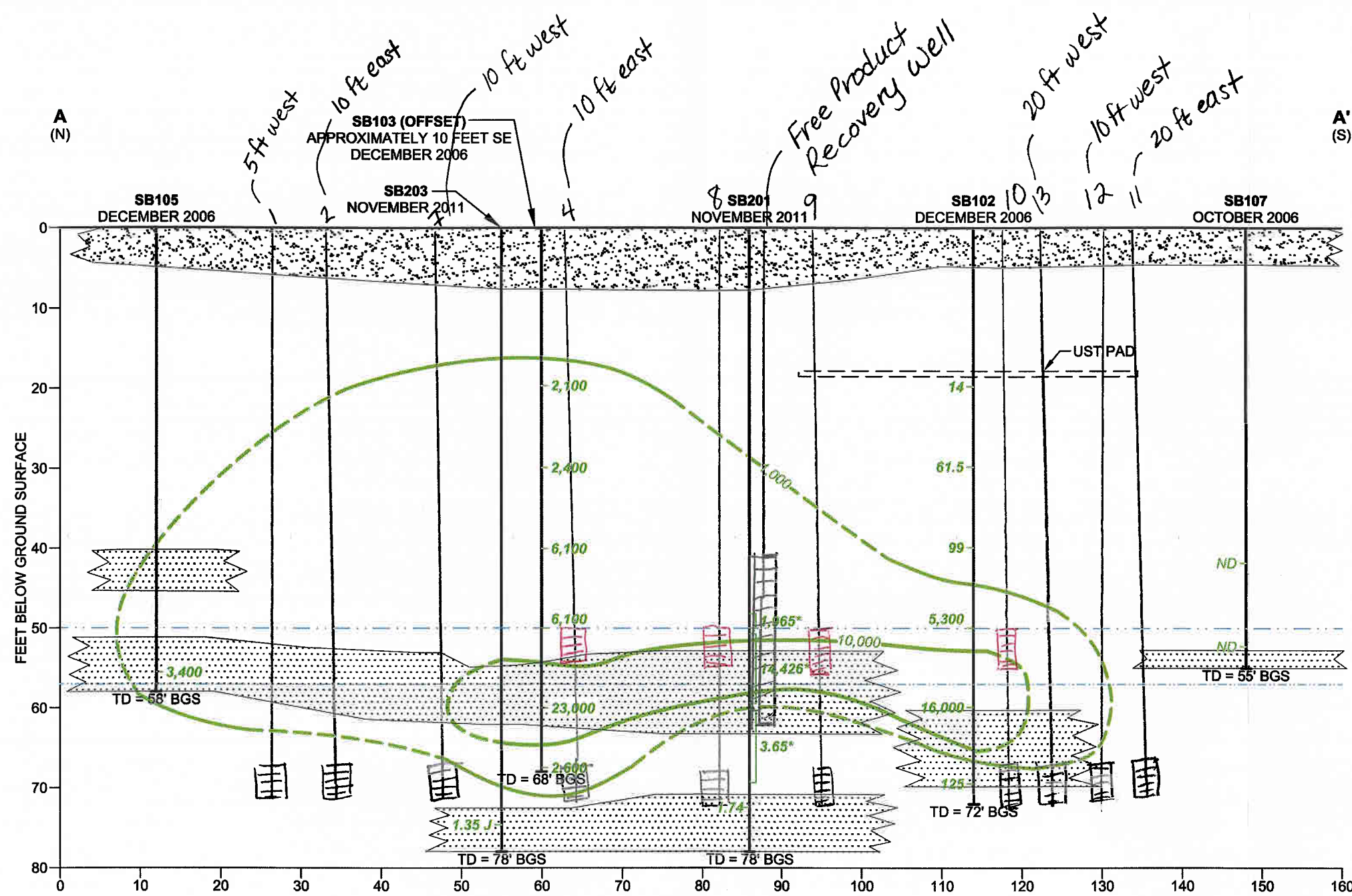

1, 2, 4, 7, 8, 9, 10, 11, 12, 13

14 Biosparging @ 70'
 8 Steam Injection @ 50'
 1 Free Product Recovery 40'-60' screen

☒ = Steam Injection
 ☒ = Biosparging

LEGEND	
	GRAVEL/ASPHALT
	F-C SAND WITH TRACE CLAY, GRAVEL AND SILT
	SILTY SAND
	1999 WATER TABLE ~57 FEET BGS
	2011 WATER TABLE ~50 FEET BGS
	TPH (1,000 mg/kg CONTOUR LINE) (DASHED WHERE INFERRED)
	TPH (10,000 mg/kg CONTOUR LINE) (DASHED WHERE INFERRED)
	SB102 SOIL BORING
	* COMPOSITE OF SB201 AND SB204
	5,300 TPH RESULT IN mg/kg
	TD = 58' BGS TOTAL DEPTH (BGS) BELOW GROUND SURFACE
	ND TPH NOT DETECTED

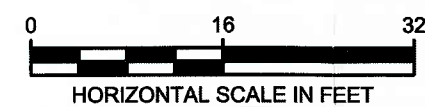

TETRA TECH

Alternative 4: Biosparging with Limited Steam Injection

CROSS SECTION SITE 4 NWIRP BETHPAGE, NEW YORK

FILE 112G02751GS02	SCALE AS NOTED
FIGURE NUMBER FIGURE C-2	REV DATE 0 08/01/12

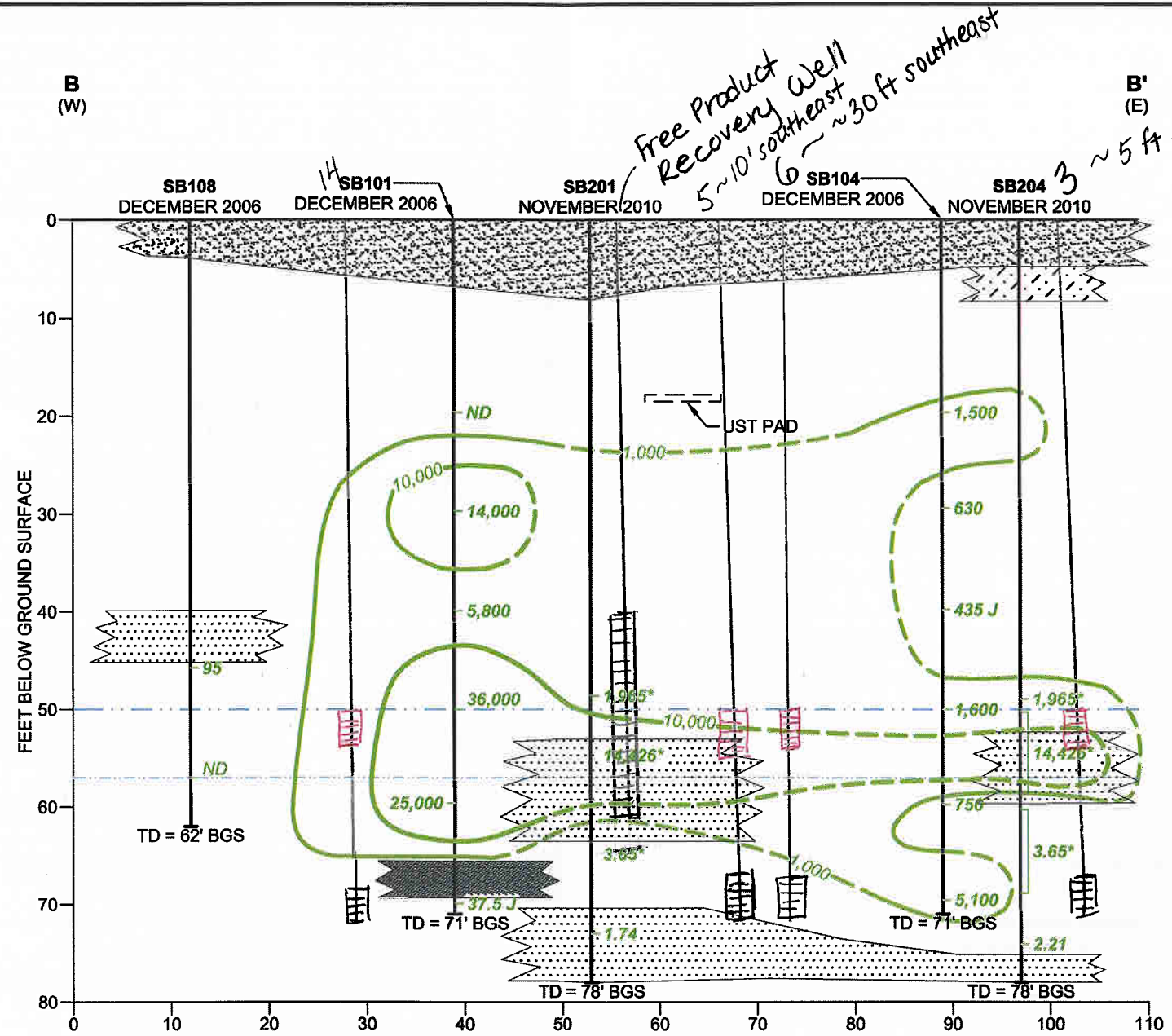

LEGEND

- SAND WITH GRAVEL/ASPHALT/CONCRETE
- F-C SAND WITH TRACE CLAY, GRAVEL AND SILT
- SILTY SAND
- CLAYEY SILT
- CLAYEY SAND
- 1999 WATER TABLE ~57 FEET BGS
- 2011 WATER TABLE ~50 FEET BGS

- 1,000 TPH (1,000 mg/kg CONTOUR LINE) (DASHED WHERE INFERRED)
- 10,000 TPH (10,000 mg/kg CONTOUR LINE) (DASHED WHERE INFERRED)
- SB102** SOIL BORING
- * COMPOSITE OF SB201 AND SB204
- 5,300 TPH RESULT IN mg/kg
- TD = 58' BGS** TOTAL DEPTH (BGS) BELOW GROUND SURFACE
- ND** TPH NOT DETECTED

= Steam Injection

= Biosparging



TETRA TECH	
Alternative 4: Biosparging with Limited steam injection CROSS SECTION WELL & R ID SITE 4 NWIRP BETHPAGE, NEW YORK	
FILE 112G02751GS02	SCALE AS NOTED
FIGURE NUMBER FIGURE C-3	REV DATE 0 08/01/12

Tetra Tech, Inc.		STANDARD CALCULATION SHEET	
CLIENT:	FILE No:	BY: SK	PAGE: 1 of 3
SUBJECT: Alternative 5 Biosparging Design Calculations for Air Compressor Sizing and Piping Layout NWIRP Bethpage Site 4 FS		CHECKED BY: DB	DATE: 7/17/2012

1. PURPOSE:

To calculate design parameters for the initial design of air sparge systems for Site 4 soils.

2. APPROACH:

Use the number of wells and total dynamic head to calculate pressure, flow, and horsepower required.

3. CALCULATE PARAMETERS FOR VERTICAL AIR SPARGE WELL SYSTEM:

Use the equation for adiabatic blower horsepower (this equation assumes an approximate 70% efficiency):

$$\text{Blower HP} = (0.31)(V_s)[(P_d/P_a)^{0.283} - 1]$$

V_s = inlet acfm
 P_d = discharge pressure
 P_a = inlet pressure = 14.7 psi

# wells	12	$h =$	P/γ
tdh	70 feet	$\gamma =$	62.4 lb/ft ³
height (h)	20 feet		
Q_{well}	5 cfm ⁽¹⁾		
Q_{total}	60 cfm		
minimum pressure (P)	8.7 psi		
pressure (P)	11 psi ⁽²⁾		
power use (HP)	3 ⁽³⁾		

1 = Typical air flow ranges from 3 to 25 standard cubic feet per minute (cfm) as referenced by the EPA: (October 1994). Chapter 7: Air Sparging. <http://www.epa.gov>. Retrieved July 11, 2012 from http://www.epa.gov/oust/pubs/tum_ch7.pdf.

2 = Pressure is calculated by dividing the height (in feet of water) by the specific weight of water (approximately 1 psi required per every 2.3 feet of hydraulic head). A safety factor of approximately 2 psi is applied.

3 = Horsepower (hp) is calculated by multiplying the theoretical power required to compress one cfm of air by the total cfm to produce the total horsepower required. An atmospheric pressure of 14.7 psi was used as the inlet pressure.

4. ESTIMATE COST OF ELECTRIC CONSUMPTION

Power Requirement From Air Blower = $P(\text{KW}) = \text{HP} \times 0.75 \text{ KW/HP} = 2 \text{ KW}$

*1HP = 0.75 KW

*Assume operation is 24 hours per day, for 1 year, or 8,640 hours of operation.

Cost per kilowatt hour⁽⁴⁾: 0.144 \$/KW hr

⁽⁴⁾ Value from April 2012 value for electricity cost for New York State. [Http://www.eia.gov](http://www.eia.gov).

Cost = KW X hours of operation/year X Cost per kilowatt hour

Cost (Blower) = 2,800 dollars/year

Tetra Tech, Inc.		STANDARD CALCULATION SHEET	
CLIENT:	FILE No:	BY: SK	PAGE: 2 of 3
SUBJECT: Alternative 5 Volume Estimation of Vertec BioGold #4 NWIRP Bethpage Site 4 FS		CHECKED BY: DB	DATE: 7/17/2012

5. ESTIMATE VOLUME OF VERTECBIO GOLD #4 NEEDED FOR SOLVENT EXTRACTION OF SITE 4 SOILS:

*Assume a 10 foot radius of injection.

$$\text{Specific Gravity (SG)}^{(1)} = 0.88 \frac{\text{lbm VertecBio Gold \#4 / ft}^3}{\text{lbm water / ft}^3}$$

⁽¹⁾ Value from VertecBio Gold #4 Data Sheet.

$$\begin{aligned} \text{density of water} &= 62.4 \text{ lbm/ft}^3 \\ 1 \text{ gallon} &= 0.1337 \text{ ft}^3 \\ \text{SG} &= 0.88 = \frac{\text{lb VertecBio Gold \#4/ft}^3}{62.4 \text{ lb water/ft}^3} \\ \text{density of VertecBio Gold \#4} &= 55 \frac{\text{lb VertecBio Gold \#4}}{\text{ft}^3} \\ &= 7.4 \frac{\text{lb VertecBio Gold \#4}}{\text{gallon}} \\ \text{density of soil} &= 112 \frac{\text{lb soil}}{\text{ft}^3} \end{aligned}$$

*Assume volume of contaminated soils (>10,000 mg/Kg TPH, from Volume Calculations) =

*Assume volume of soil is multiplied by a factor of 3 for safety:

$$\begin{aligned} A_{1(\text{unsaturated soils})} &= 3,300 \text{ ft}^3 = 9,900 \text{ ft}^3 \\ A_{2(\text{saturated soils})} &= 32,000 \text{ ft}^3 = 96,000 \text{ ft}^3 \end{aligned}$$

Unsaturated soils:

$$\begin{aligned} \text{Saturation concentration} &= 16,000 \text{ mg/Kg} = 0.016 \\ \text{Volume} &= \text{saturation concentration} \times \text{volume unsaturated soils} \times \text{density VertecBio Gold \#4} \\ &= 18,000 \text{ lb VertecBio Gold \#4} \\ \text{Volume needed in unsaturated soils} &= 2,400 \text{ gallons} \end{aligned}$$

Saturated soils:

$$\begin{aligned} \text{Saturation concentration} &= 16,000 \text{ mg/Kg} = 0.016 \\ \text{Volume} &= \text{saturation concentration} \times \text{volume saturated soils} \times \text{density VertecBio Gold \#4} \\ &= 170,000 \text{ lb VertecBio Gold \#4} \\ \text{Volume needed in saturated soils} &= 23,000 \text{ gallons} \end{aligned}$$

$$\text{Volume VertecBio Gold \#4 needed for saturation} = 25,400 \text{ gallons}$$

$$\text{*Assume a factor of safety of 1.1 is applied} = 28,000 \text{ gallons}$$

Total Volume of VertecBio Gold #4 needed = Saturation volume + 3 rinse volumes

$$1 \text{ rinse volume} = 28,000$$

$$\text{Volume VertecBio Gold \#4 needed} = 112,000 \text{ gallons}$$

Total Volume of VertecBio Gold #4 Needed for Solvent Extraction:

$$\text{*Assume a factor of safety of 1.1 is applied} = 120,000 \text{ gallons}$$

Tetra Tech, Inc.		STANDARD CALCULATION SHEET	
CLIENT:	FILE No:	BY: SK	PAGE: 3 of 3
SUBJECT: Alternative 5 Volume Estimation of Vertec BioGold #4 NWIRP Bethpage Site 4 FS		CHECKED BY: DB	DATE: 7/17/2012

6. CALCULATE THE VOLUME OF TPH REMOVED (AS WASTE OIL):

*Assume 3 passes with VertecBio Gold #4 needed for removal, with 50% removal with each pass:

$$\begin{aligned} \text{\%Removal} &= 1 - (0.5^3) = 0.875 \\ \text{Volume TPH} &= 0.875 * \text{Total Volume of TPH (From Volume Calculations)} \\ &= 9,888 \text{ gallons} = 9,800 \text{ gallons} \end{aligned}$$

7. CALCULATE THE TOTAL VOLUME OF VERTECBIO GOLD #4 TO BE DISPOSED:

$$\begin{aligned} \text{Volume} &= \text{Total Volume VertecBio Gold #4} - \text{Saturation Volume VertecBio Gold #4} \\ \text{Volume} &= 90,000 \text{ gallons} \end{aligned}$$

Note that some values were rounded down to be conservative of the actual volume that can be removed.

Panther WA 3032-3300D

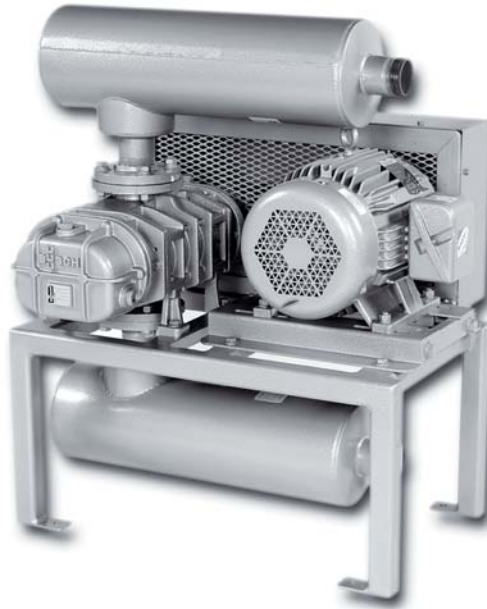

Panther WA 3065 D

Description

The Busch Panther blower is a rotary lobe, positive displacement blower that is designed for either pressure or vacuum applications. Vacuum or pressure is produced by two non-contacting rotors in an oil-free pumping chamber creating a clean, efficient and wear free environment.

Wearing parts, such as bearings and gears, are separated from the

pumping chamber by labyrinth seals yielding a long service life. Heavy duty construction and oil lubricated bearings on both the gear end and drive end of the blower ensure reliable operation.

The Panther blower features a tri-lobe design that increases efficiency and decreases sound levels.

Features

- Low maintenance
- High efficiency
- Tri-lobe design
- Dry, non-contacting pumping chamber
- Oil lubricated bearings on both ends
- Labyrinth seals
- Heavy duty construction

Operating Principle

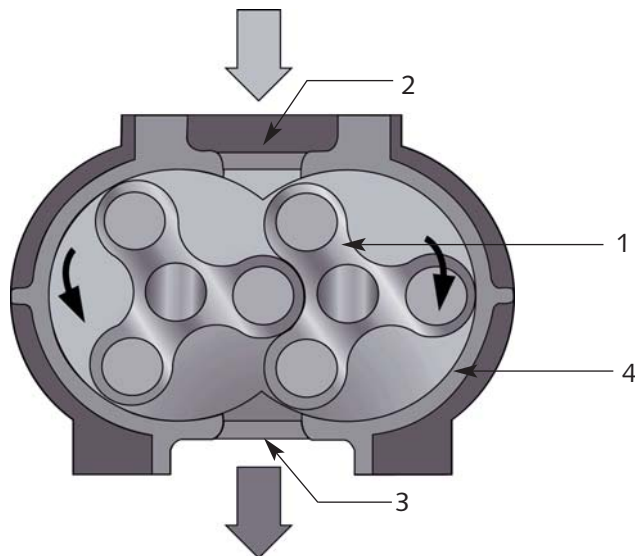

1. Rotor
2. Inlet
3. Outlet
4. Cylinder

Operating Principle

The tri-lobe Panther by Busch, works according to the proven rotary lobe principle. Operation is both simple and effective. Two rotors with identical profiles rotate in opposite directions within a casing. As they rotate, air is drawn into the space between each rotor and the casing where it is trapped, transported and discharged by the rotation. This occurs with each revolution of each rotor and therefore six times for each revolution of the drive shaft. There is no mechanical contact between the rotors and cylinder. Therefore no oil lubrication is required in the pumping chamber.

Standard Equipment

- Rotary lobe blower on base frame
- Discharge silencer
- Inlet side silencer
- Motor mounting assembly incl. V-belt drive
- Motor
- Belt guard

Application

The blower speed and motor size can be selected specifically to suit the exact needs of the following applications:

- Food processing
- Hold down applications
- Lifting and transport systems
- Milking
- Pneumatic conveying
- Soil remediation
- Textile applications
- Waste treatment aeration
- Wood routers



Technical Data

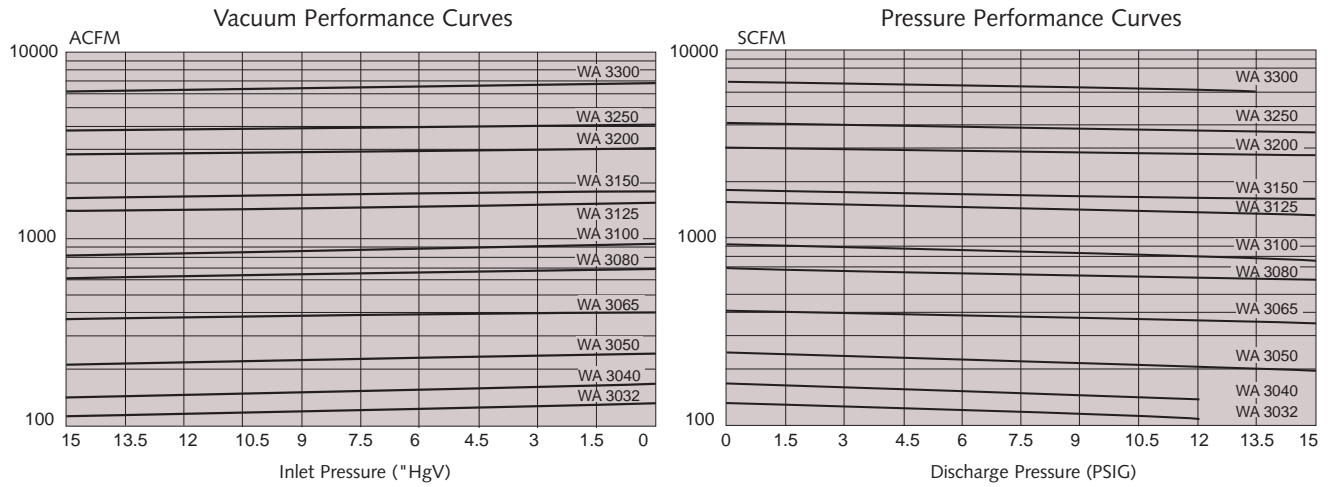

Maximum curve shown (actual capacity depends on motor speed and power selected).

Technical Data		WA 3032 D	WA 3040 D	WA 3050 D	WA 3065 D	WA 3080 D	WA 3100 D
Panther Model							
Nominal pumping speed	CFM	35-131	53-166	57-243	109-407	170-687	205-931
Maximum vacuum	"HgV	15	15	15	15	15	15
Ultimate pressure	PSIG	12	12	15	15	15	15
Motor power range	HP	1-10	1-15	1-25	1-40	3-60	3-75
Blower speed range	RPM	1500-3750	1500-3750	1150-3550	1150-3550	1150-3550	850-3250
Bare shaft blower weight	Lbs	110	121	165	198	330	440

Technical Data		WA 3125 D	WA 3150 D	WA 3200 D	WA 3250 D	WA 3300 D
Panther Model						
Nominal pumping speed	CFM	360-1571	470-1796	604-3030	978-4080	2564-6829
Maximum vacuum	"HgV	15	15	15	15	15
Ultimate pressure	PSIG	15	15	15	15	13.5
Motor power range	HP	5-125	5-150	10-270	15-350	30-450
Blower speed range	RPM	750-2850	750-2550	600-2400	600-2100	600-1500
Bare shaft blower weight	Lbs	858	990	1650	2200	3080

Performance data based on ambient conditions of 14.7 PSIG and 70° F, and have a tolerance of +/- 10%.

Rotary Lobe, Positive Displacement Blower



Dimensions

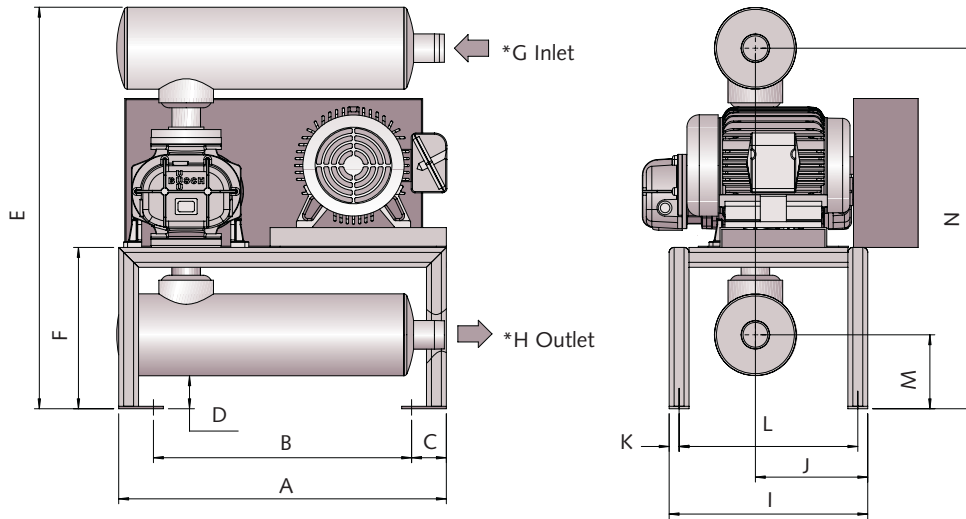

Dimensions	A	B	C	D	E	F	G	H	I	J	K	L	M	N
WA 3050 D	33	26	3 ¹ / ₂	2 ³ / ₄	41	16 ¹ / ₄	2 ¹ / ₂	2 ¹ / ₂	20	10 ¹ / ₄	1	18	6 ⁷ / ₈	36 ⁷ / ₈
WA 3065 D	33	26	3 ¹ / ₂	2 ¹ / ₈	41 ³ / ₄	16 ¹ / ₄	3	3	20	11 ³ / ₈	1	18	6 ¹ / ₄	37 ⁵ / ₈
WA 3080 D	36	29	3 ¹ / ₂	4 ³ / ₄	54 ¹ / ₂	22 ¹ / ₄	4	4	22	12 ³ / ₄	1	20	9 ⁷ / ₈	49 ¹ / ₈
WA 3100 D	42	33	4 ¹ / ₂	5 ⁷ / ₈	55 ³ / ₈	23 ³ / ₈	4	4	28	15 ³ / ₈	1 ¹ / ₂	25	11	50 ¹ / ₄
WA 3125 D	48	39	4 ¹ / ₂	5 ³ / ₈	71	29 ³ / ₈	6	6	32	16 ¹ / ₂	1 ¹ / ₂	29	12 ¹ / ₂	63 ⁷ / ₈

All dimensions in inches unless otherwise noted.
 Dimensions of specific units depend on motor speed and application type selected.
 Dimensions of additional sizes are available by request.
 *3" & smaller is MNPT, 4" & larger is flanged.

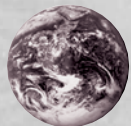

Busch - all over the world in industry

ISO 9001-2000 Registered Company

Busch LLC 516 Viking Drive Virginia Beach, VA 23452
Phone (757) 463-7800 FAX (757) 463-7407

www.buschusa.com
1-800-USA-PUMP

Amsterdam Barcelona Birmingham Basel Brussels Dublin Göteborg Helsinki Istanbul Copenhagen Kuala Lumpur Milan Maulburg Melbourne Montreal Moscow
 New York New Plymouth Oslo Paris San Jose São Paulo Seoul Singapore Taipei Tokyo Vienna
 C-55

12-B1/22-B1

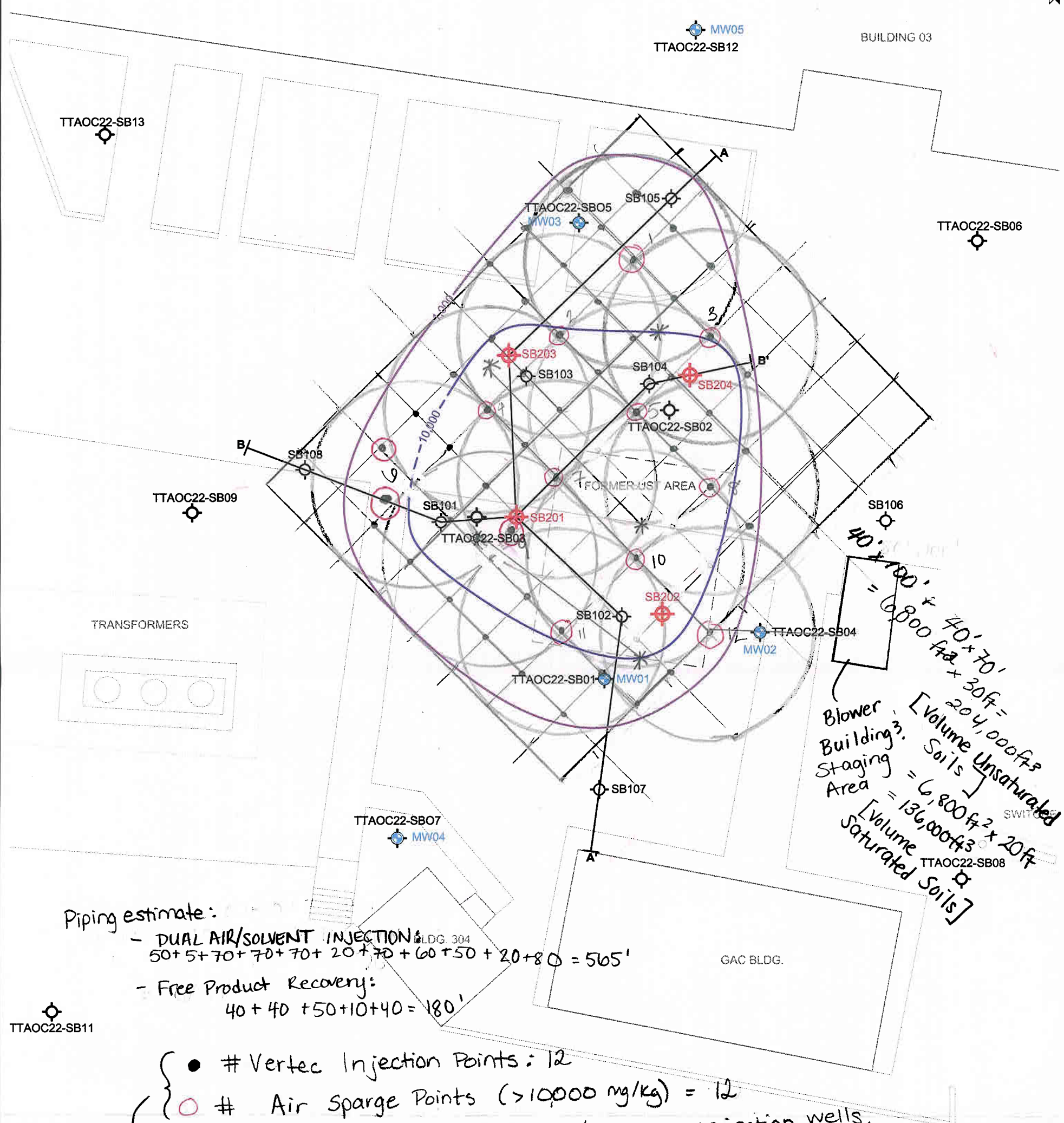

Blower Building Staging Area = 40' x 100' + 40' x 70' = 6,800 ft² x 30ft = 204,000 ft³ [Volume Unsaturated Soils]
 = 6,800 ft² x 20ft = 136,000 ft³ [Volume Saturated Soils]

Piping estimate:

- DUAL AIR/SOLVENT INJECTION: 50 + 5 + 70 + 70 + 70 + 20 + 70 + 60 + 50 + 20 + 80 = 565'
- Free Product Recovery: 40 + 40 + 50 + 10 + 40 = 180'

- # Vertec Injection Points: 12
- # Air Sparge Points (>10,000 mg/kg) = 12
- ⊙* Note: Wells are DUAL AIR/SOLVENT injection wells.
- * = Free Product Recovery well, 5
- = Shallow (20'TDH) vertec Injection Point, 38
- Total Vertec Injection: 38 + 12 = 50

LEGEND

- EXISTING MONITORING WELL LOCATION
- PREVIOUS SOIL BORING LOCATION
- ⊙ NOVEMBER 2010 SOIL BORING LOCATION
- SOIL CONTAMINATION IN mg/kg.

NOTE: mg/kg = MILLIGRAMS PER KILOGRAM

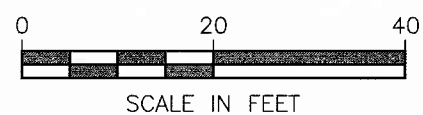

TETRA TECH

Alternative 5: solvent Extraction with WELLGRID + Biosparging

SITE 4
NWRP
BETHPAGE, NEW YORK

FILE 112G02751GM02	SCALE AS NOTED
FIGURE NUMBER FIGURE D-1	REV 0
	DATE 07/18/12

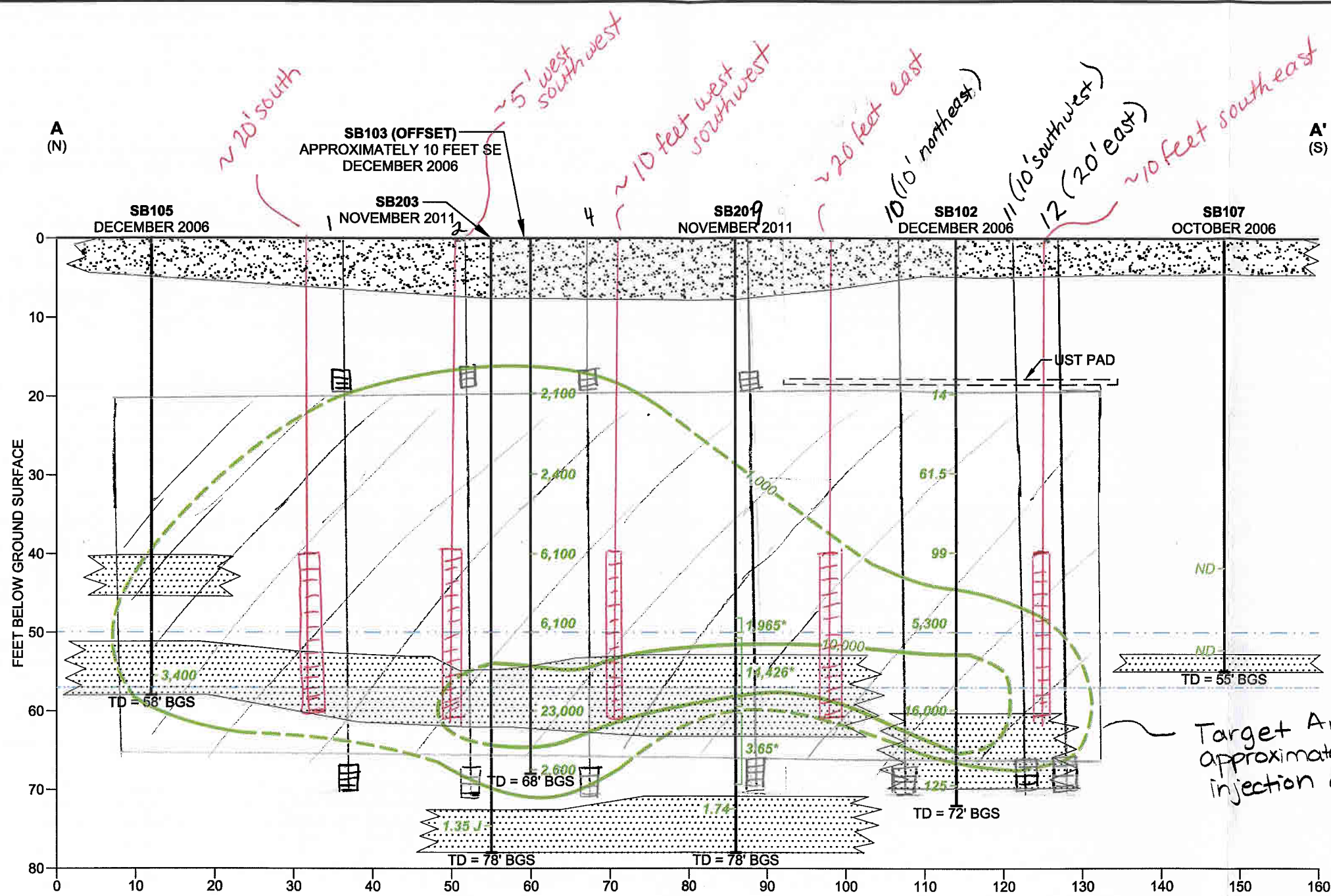

* Additional shallow wells not shown.

Wells screened to 70'.
Dual air/solvent injection wells.

Wells shown: 1, 2, 4, 9, 10, 11, 12

Total wells: 7
on this cross-section

Target Area for solvent extraction approximately 45' thick. Solvent injection occurs below water table.

Free Product Recovery Well
5 @ 40'-60' bgs

LEGEND

- GRAVEL/ASPHALT
- F-C SAND WITH TRACE CLAY, GRAVEL AND SILT
- SILTY SAND
- 1999 WATER TABLE ~57 FEET BGS
- 2011 WATER TABLE ~50 FEET BGS
- 10,000 TPH (10,000 mg/kg CONTOUR LINE) (DASHED WHERE INFERRED)
- 1,000 TPH (1,000 mg/kg CONTOUR LINE) (DASHED WHERE INFERRED)

- SB102 SOIL BORING
- * COMPOSITE OF SB201 AND SB204
- 5,300 TPH RESULT IN mg/kg
- TD = 58' BGS TOTAL DEPTH (BGS) BELOW GROUND SURFACE
- ND TPH NOT DETECTED

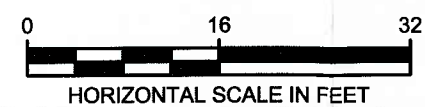

Alternative 5: Solvent Extraction with Biosparging Well Grid

CROSS SECTION
SITE 4
NWIRP
BETHPAGE, NEW YORK

FILE 112G02751GS02	SCALE AS NOTED
FIGURE NUMBER FIGURE D-2	REV 0
	DATE 08/01/12

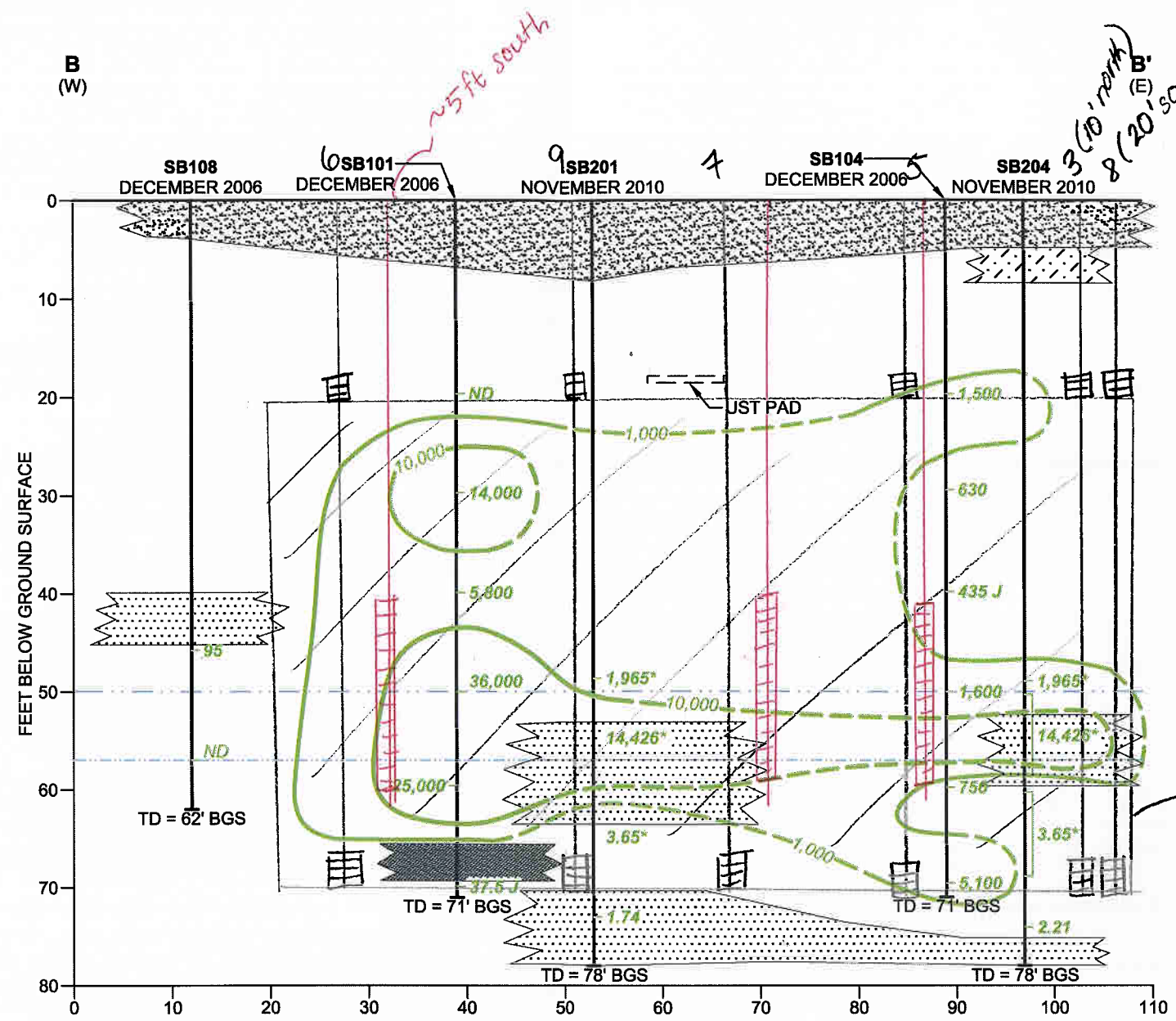

* Additional shallow wells not shown.

Wells screened to 70'
 Dual air/solvent injection wells.
 Wells shown: 3, 5, 6, 7, 8, 9
 Total wells on this cross section: 6

Target Area for solvent extraction approximately 50' thick. Solvent injection occurs below water table.

= Free Product Recovery Well
 40'-60' TDH
 (2 not pictured)

LEGEND

	SAND WITH GRAVEL/ASPHALT/CONCRETE
	F-C SAND WITH TRACE CLAY, GRAVEL AND SILT
	SILTY SAND
	CLAYEY SILT
	CLAYEY SAND
	1999 WATER TABLE ~57 FEET BGS
	2011 WATER TABLE ~50 FEET BGS

	TPH (1,000 mg/kg CONTOUR LINE) (DASHED WHERE INFERRED)
	TPH (10,000 mg/kg CONTOUR LINE) (DASHED WHERE INFERRED)
	SB102 SOIL BORING
	* COMPOSITE OF SB201 AND SB204
	TPH RESULT IN mg/kg
	TOTAL DEPTH (BGS) BELOW GROUND SURFACE
	TPH NOT DETECTED

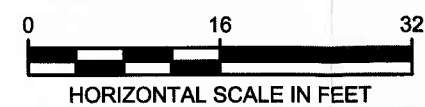

TETRA TECH	
Alternative 5: Solvent Extraction with Biosparging CROSS SECTION WELL GRID SITE 4 NWIRP BETHPAGE, NEW YORK	
FILE 112G02751GS02	SCALE AS NOTED
FIGURE NUMBER FIGURE D-3	REV 0 DATE 08/01/12

Tetra Tech, Inc.		STANDARD CALCULATION SHEET	
CLIENT:	FILE No:	BY: SK	PAGE: 1 of 4
SUBJECT: Alternative 6A, 6B Mass Calculations for Excavation NWIRP Bethpage Site 4 FS		CHECKED BY: DB	DATE: 7/17/2012

1. PURPOSE:

Calculate the volume of soil to be excavated at the site if a full scale excavation is conducted for all contaminated soils greater than 1,000 mg/Kg (Alternative 6A) and if a partial excavation is conducted for all contaminated soils greater than 10,000 mg/Kg (Alternative 6B).

2. APPROACH:

Existing data show intervals of varying contamination levels, as seen in Figures 2-2 to 2-4. The top 20 feet of soils contain limited to no contamination, and therefore can be used as backfill. Soils are split by area into unsaturated and saturated and used to calculate the total mass of soil to be excavated. The mass of backfill soil included the top 20 feet of clean soils and any soils that are below the target level of contamination.

3. DATA INTERVALS:

0 - 20 feet below ground surface (bgs):

Soil at this depth is considered clean for backfill.

20 - 50 feet bgs:

Soil at this depth is located above the water table.

50 - 70 feet bgs:

Soil at this depth is located below the water table and is considered saturated.

4. CONVERSION FACTORS:

$$1 \text{ yd}^3 = 27 \text{ ft}^3$$

Tetra Tech, Inc.		STANDARD CALCULATION SHEET	
CLIENT:	FILE No:	BY: SK	PAGE: 2 of 4
SUBJECT: Alternative 6A Mass Calculations for Excavation NWIRP Bethpage Site 4 FS		CHECKED BY: DB	DATE: 7/17/2012

See Figure E-1 for boundaries drawn to calculate soil masses. Not that the boundary boxes were drawn to estimate the approximate soil mass, where the actual excavation will more directly follow the given contamination boundary lines (oblong oval boundary lines). Figures E-2 and E-3 show cross section views of the planned excavation.

5. CALCULATE THE TOTAL VOLUME OF MATERIAL TO BE EXCAVATED:

Unsaturated soils (0 - 50 feet bgs):

$$V_{\text{unsaturated}} = A_1 (\text{contamination thickness} = 50 \text{ feet}) + A_2 (\text{contamination thickness} = 50 \text{ feet})$$

$$A_1 = 40 \quad X \quad 130 = 5,200$$

$$A_2 = 40 \quad X \quad 75 = 3,000$$

$$V_{\text{unsaturated}} = 410,000 \text{ ft}^3 = 15,000 \text{ yd}^3$$

Saturated soils (50 - 70 feet bgs):

$$V_{\text{saturated}} = A_1 (\text{contamination thickness} = 20 \text{ feet}) + A_2 (\text{contamination thickness} = 20 \text{ feet})$$

$$A_1 = 40 \quad X \quad 130 = 5,200$$

$$A_2 = 40 \quad X \quad 75 = 3,000$$

$$V_{\text{saturated}} = 164,000 \text{ ft}^3 = 6,000 \text{ yd}^3$$

$$V_{\text{total}} = V_{\text{unsaturated}} + V_{\text{saturated}}$$

$$V_{\text{total}} = 21,000 \text{ yd}^3$$

6. CALCULATE THE TOTAL UNCONTAMINATED SOIL TO BE USED FOR BACKFILL:

Backfill (clean soils to be reused):

$$V_{\text{backfill}} = V_{\text{total}} - [V_{\text{contaminated}}^{(1)} \times 1.1^{(2)}]$$

$$V_{\text{backfill}} = 14,000 \text{ yd}^3$$

⁽¹⁾ $V_{\text{contaminated}}$ is from the total volume of contaminated soils for >1,000 mg/Kg TPH from the volume and mass calculations appendix.

⁽²⁾ A factor of 1.1 was applied to the existing calculation of contaminated soil to provide a factor of safety for disposal estimates.

7. CALCULATE THE TOTAL VOLUME OF CONTAMINATED SOILS FOR DISPOSAL:

$$V_{\text{disposal}} = 7,000 \text{ yd}^3$$

Tetra Tech, Inc.		STANDARD CALCULATION SHEET	
CLIENT:	FILE No:	BY: SK	PAGE: 3 of 4
SUBJECT: Alternative 6B Mass Calculations for Excavation NWIRP Bethpage Site 4 FS		CHECKED BY: DB	DATE: 7/17/2012

See Figure E-1 for boundaries drawn to calculate soil masses. Not that the boundary boxes were drawn to estimate the approximate soil mass, where the actual excavation will more directly follow the given contamination boundary lines (oblong oval boundary lines). Figures E-2 and E-3 show cross section views of the planned excavation.

8. CALCULATE THE TOTAL VOLUME OF MATERIAL TO BE EXCAVATED:

Unsaturated soils (0 - 50 feet bgs):

$$V_{\text{unsaturated}} = A_1 \text{ (contamination thickness = 50 feet)}$$

$$A_1 = 60 \times 55 = 3,300$$

$$V_{\text{unsaturated}} = 165,000 \text{ ft}^3 = 6,000 \text{ yd}^3$$

Saturated soils (50 - 65 feet bgs):

$$V_{\text{saturated}} = A_1 \text{ (contamination thickness = 15 feet)}$$

$$A_1 = 60 \times 55 = 3,300$$

$$V_{\text{saturated}} = 49,500 \text{ ft}^3 = 2,000 \text{ yd}^3$$

$$V_{\text{total}} = V_{\text{unsaturated}} + V_{\text{saturated}}$$

$$V_{\text{total}} = 8,000 \text{ yd}^3$$

9. CALCULATE THE TOTAL UNCONTAMINATED SOIL TO BE USED FOR BACKFILL:

$$V_{\text{backfill}} = V_{\text{total}} - [V_{\text{contaminated}}^{(1)} \times 1.1^{(2)}]$$

$$V_{\text{backfill}} = 6,600 \text{ yd}^3$$

⁽¹⁾ $V_{\text{contaminated}}$ is from the total volume of contaminated soils for >1,000 mg/Kg TPH from the volume and mass calculations appendix.

⁽²⁾ A factor of 1.1 was applied to the existing calculation of contaminated soil to provide a factor of safety for disposal estimates.

10. CALCULATE THE TOTAL VOLUME OF CONTAMINATED SOILS FOR DISPOSAL:

$$V_{\text{disposal}} = 1,400 \text{ yd}^3$$

Tetra Tech, Inc.		STANDARD CALCULATION SHEET	
CLIENT:	FILE No:	BY: SK	PAGE: 4 of 4
SUBJECT: Alternative 6A/6B Mass Calculations for Off-site Disposal NWIRP Bethpage Site 4 FS		CHECKED BY: DB	DATE: 7/17/2012

11. CALCULATE THE AMOUNT OF CONTAMINATED SOIL TO BE REMOVED DURING EXCAVATION (TRUCKING REMOVAL ESTIMATES):

*Assume that a factor of 1.3 will be applied to existing estimates of total soil to be removed (from Sections 7 and 10 of calculations) to account for the difference between loose versus impacted soils.

* Assume soil density = 112 lb/ft³

Alternative 6A:

Total soils to be removed = total contaminated soils X density of soils X 1.3

Total soils to be removed = 14,000 tons

Alternative 6B:

Total soils to be removed = total contaminated soils X density of soils X 1.3

Total soils to be removed = 2,800 tons

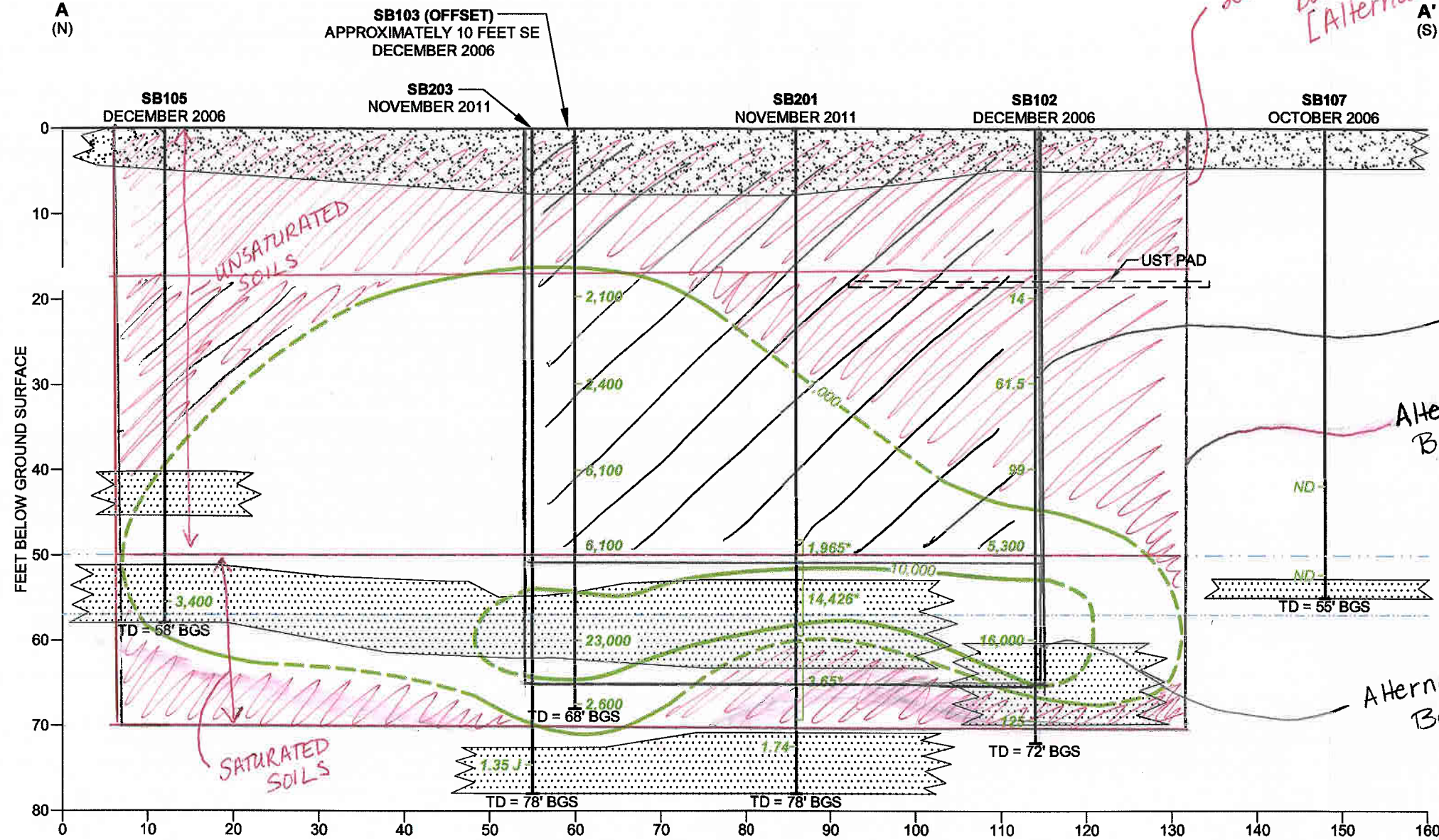

LEGEND	
	GRAVEL/ASPHALT
	F-C SAND WITH TRACE CLAY, GRAVEL AND SILT
	SILTY SAND
	1999 WATER TABLE ~57 FEET BGS
	2011 WATER TABLE ~50 FEET BGS
	TPH (1,000 mg/kg CONTOUR LINE) (DASHED WHERE INFERRED)
	TPH (10,000 mg/kg CONTOUR LINE) (DASHED WHERE INFERRED)
	SB102 SOIL BORING
	* COMPOSITE OF SB201 AND SB204
	5,300 TPH RESULT IN mg/kg
	TD = 58' BGS TOTAL DEPTH (BGS) BELOW GROUND SURFACE
	ND TPH NOT DETECTED

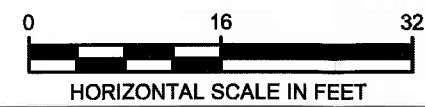

TETRA TECH

Alternative 6A & 6B EXCAVATION
 CROSS SECTION A - A'
 SITE 4
 NWIRP
 BETHPAGE, NEW YORK

FILE 112G02751GS02	SCALE AS NOTED
FIGURE NUMBER FIGURE E-2	REV DATE 0 05/21/12

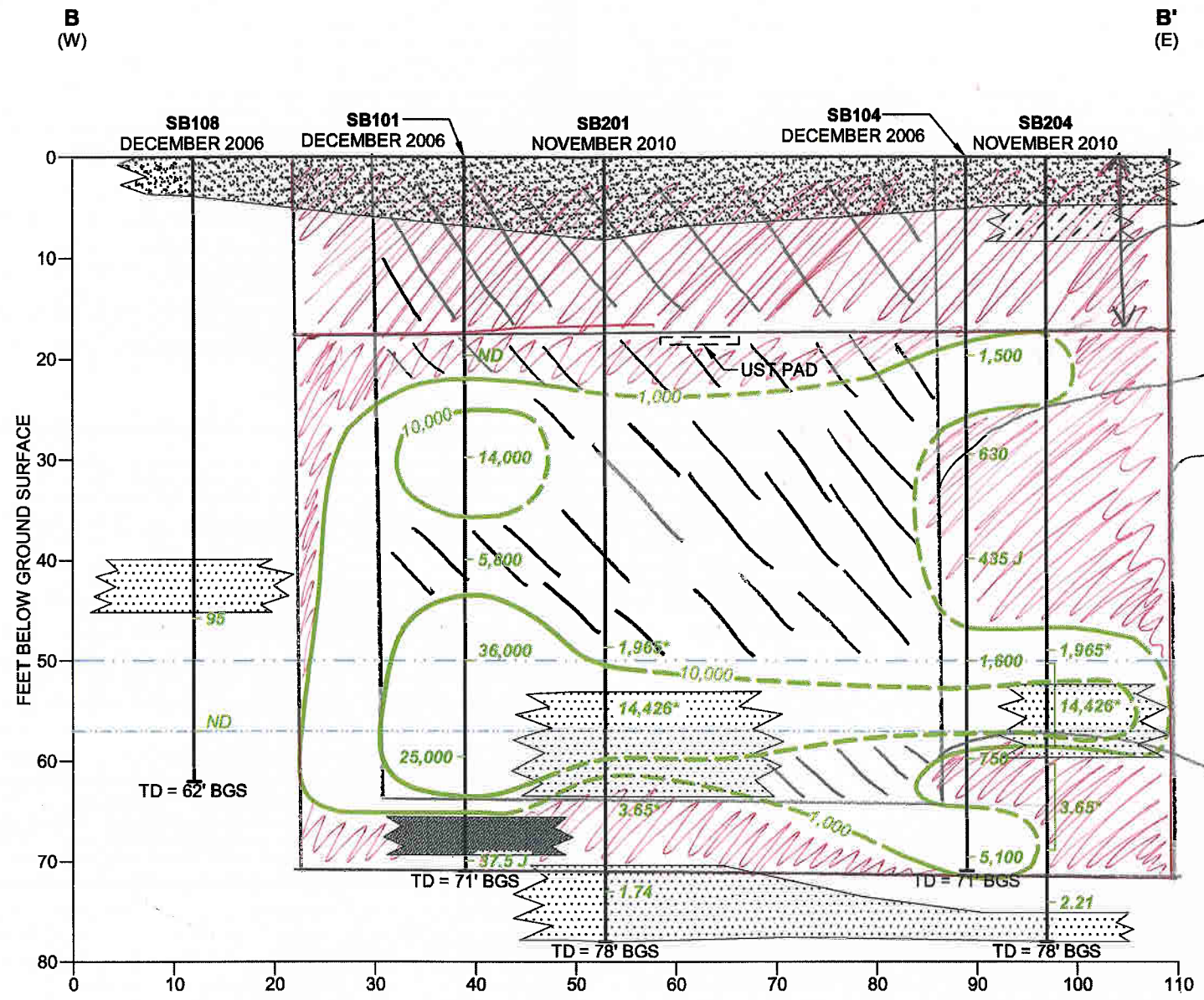

Alternative 6A
20 feet deep x 80 feet deep
backfill soils

Alternative 6B backfill =
(20 feet x 55 feet) + Soils (1,000-10,000
mg/kg TPH)

Alternative 6A - Full Excavation
Boundary
[Length: 80 feet
Depth: 70 feet]

Alternative 6B - Partial Excavation
Boundary
[Length: 55 feet
Depth: 65 feet]

LEGEND

- SAND WITH GRAVEL/ASPHALT/CONCRETE
- F-C SAND WITH TRACE CLAY, GRAVEL AND SILT
- SILTY SAND
- CLAYEY SILT
- CLAYEY SAND
- TPH (1,000 mg/kg CONTOUR LINE)
(DASHED WHERE INFERRED)

- TPH (10,000 mg/kg CONTOUR LINE)
(DASHED WHERE INFERRED)
- SB102 SOIL BORING
- * COMPOSITE OF SB201 AND SB204
- 5,300 TPH RESULT IN mg/kg
- TD = 58' BGS TOTAL DEPTH (BGS) BELOW GROUND SURFACE
- ND TPH NOT DETECTED

C-65

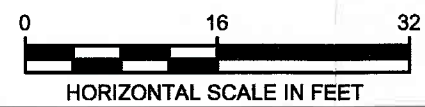

TETRA TECH	
Alternative 6A & 6B EXCAVATION CROSS SECTION B - B' SITE 4 NWIRP BETHPAGE, NEW YORK	
FILE 112G02751GS02	SCALE AS NOTED
FIGURE NUMBER FIGURE E-3	REV DATE 0 05/21/12

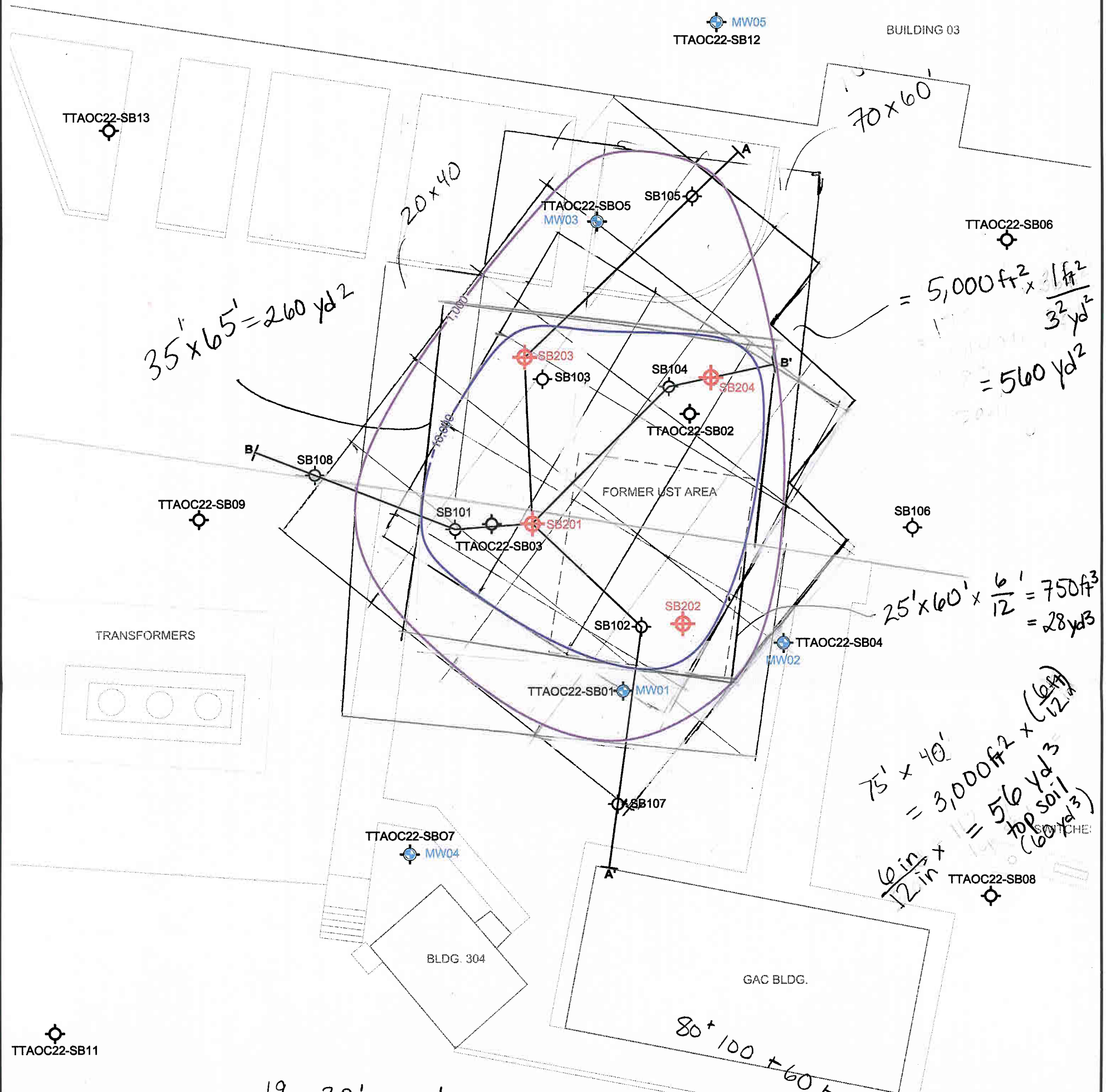

19 20' x 20' grids 6A (shoring) - 65+65+60+60+50+15+20+20+15 = 360ft P
 10 20' x 20' grids 6B (shoring) - 65+65+60+60 = 250ft P

6A : 60yd³ soil
 560yd² paving

6B : 30yd³ soil
 260yd² paving

- LEGEND**
- EXISTING MONITORING WELL LOCATION
 - PREVIOUS SOIL BORING LOCATION
 - NOVEMBER 2010 SOIL BORING LOCATION
 - SOIL CONTAMINATION IN mg/kg.

NOTE: mg/kg = MILLIGRAMS PER KILOGRAM

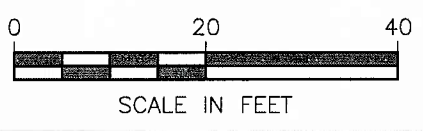

TT TETRA TECH

ESTIMATES FOR EXCAVATION
GRIDS, TOP SOIL AND PAVING VOLUMES
SITE 4
NWRP
BETHPAGE, NEW YORK

FILE 112G02751GM02	SCALE AS NOTED
FIGURE NUMBER FIGURE E-4	REV 0
	DATE 07/18/12

APPENDIX D
COST ESTIMATES

Alternative 1 - No Action

Capital Cost:	\$0
O&M:	\$0
NPV:	\$0

Alternative 2 - Limited Action And Monitored Natural Attenuation

Capital Cost

Item	Description	Quantity	Units	Unit Cost	Extended Cost
1	Reporting				
1.1	UPF-SAP/Work Plan for long term monitoring	1	Each	\$30,000	\$30,000
	Subtotal (Item 1)				\$30,000
	Total Construction Cost				\$30,000

Annual O&M Cost (2)

Item	Description	Quantity	Units	Unit Cost	Extended Cost
1.	5-Year Review/LUCs	1	each	\$30,000	\$30,000
2.	Annual GW sampling, analysis, and reporting				
2.1	Laboratory Analysis (VOCs, SVOCs, and Metals)	11	Each	\$400	\$4,400
2.2	Field Labor	4	Day	\$1,200	\$4,800
2.5	Annual Reporting	1	Each	\$20,000	\$20,000
2.6	Contingency (20%)				\$5,840
	Subtotal (Item 2)				\$35,040
3.	10 yr soil sampling, analysis, and reporting				
3.1	Laboratory Analysis (TPH and PAHs)	20	Each	\$200	\$4,000
3.2	Field Labor	3	Day	\$1,200	\$3,600
3.3	Drilling/Split Spoon to 70 ft (4 borings)	4	each	\$3,500	\$14,000
3.4	Reporting	1	Each	\$20,000	\$20,000
3.5	Contingency (20%)				\$8,320
	Subtotal (Item 3)				\$49,920

Cost Summary (without discount factor).

	Capital	O&M	Duration (year)	Total Cost
1 UPF-SAP/Work Plan for long term monitoring	\$30,000	\$0	0	\$30,000
2 5-year Review/LUC	\$0	\$30,000	6	\$180,000
3 Annual GW sampling, analysis, and reporting	\$0	\$35,040	30	\$1,051,200
4 10 Year soil sampling, analysis, and reporting	\$0	\$49,920	3	\$149,760
Total Alternative 2	\$30,000	\$114,960		\$1,410,960

Present Value Calculation

As of	Dec-13	interest rate (OBM)	2.00%	
	Cost	NPW	DF	
2013	\$ 30,000	\$ 30,000		
2014	\$ 65,040		63,765	0.980
2015	\$ 35,040		33,679	0.961
2016	\$ 35,040		33,019	0.942
2017	\$ 35,040		32,372	0.924
2018	\$ 35,040		31,737	0.906
2019	\$ 65,040		57,754	0.888
2020	\$ 35,040		30,504	0.871
2021	\$ 35,040		29,906	0.853
2022	\$ 35,040		29,320	0.837
2023	\$ 84,960		69,697	0.820
2024	\$ 65,040		52,309	0.804
2025	\$ 35,040		27,629	0.788
2026	\$ 35,040		27,087	0.773
2027	\$ 35,040		26,556	0.758
2028	\$ 35,040		26,035	0.743
2029	\$ 65,040		47,378	0.728
2030	\$ 35,040		25,024	0.714
2031	\$ 35,040		24,534	0.700
2032	\$ 35,040		24,053	0.686
2033	\$ 84,960		57,176	0.673
2034	\$ 65,040		42,912	0.660
2035	\$ 35,040		22,665	0.647
2036	\$ 35,040		22,221	0.634
2037	\$ 35,040		21,785	0.622
2038	\$ 35,040		21,358	0.610
2039	\$ 65,040		38,867	0.598
2040	\$ 35,040		20,529	0.586
2041	\$ 35,040		20,126	0.574
2042	\$ 35,040		19,731	0.563
2043	\$ 84,960		46,904	0.552
	\$ 1,410,960	\$	1,056,631	\$ 22

Alternative 3 - Steam Injection/Free Product Recovery

Capital Cost

Item	Description	Quantity	Units	Unit Cost	Extended Cost
1.	Baseline GW Sampling and analysis				
1.1	Laboratory Analysis (VOCs, SVOCs, and Metals)	11	Each	\$400	\$4,400
1.2	Field Labor	4	Day	\$1,200	\$4,800
1.3	UPF-SAP/Work Plan for long term monitoring	1	Each	\$30,000	\$30,000
1.4	Reporting	1	Each	\$20,000	\$20,000
	Subtotal (Item 1)				\$59,200
2.	General Mobilization/Demobilization				
2.1	Construction Facilities (trailer, utilities) - 6 months	6	month	\$2,000	\$12,000
2.2	Decon Pad Construction	1	LS	\$800	\$800
2.3	Utility Clearance	1	LS	\$2,000	\$2,000
2.4	Construction Oversight Start-Up (Supervisor, QC/H&S)	2	Month	\$40,000	\$80,000
	Subtotal (Item 2)				\$94,800
3.	Building and Utilities				
3.1	Building	600	SQ FT	\$300	\$180,000
3.2	Water Supply	1	Each	\$20,000	\$20,000
3.3	Sewer Connection	1	Each	\$10,000	\$10,000
3.4	Electricity Connection	1	Each	\$50,000	\$50,000
3.4	Construction Oversight (Supervisor, QC/H&S)	2	Month	\$40,000	\$80,000
	Subtotal (Item 3)				\$340,000
4.	Steam Injection				
4.1	1" Injection Wells (14 Clusters - 12 at 50 and 60, 4 at 70 feet)	1,580	FT	\$80	\$126,400
4.2	Steam Generator/blowdown pump (50,000 BTU per Hour)	1	LS	\$15,000	\$15,000
4.3	Water Supply Connection	1	LS	\$5,000	\$5,000
4.4	Steam Injection Piping (2 inch steel - underground)	280	FT	\$50	\$14,000
4.5	Piping Misc.	1	LS	\$20,000	\$20,000
4.6	Power and Controls	1	LS	\$50,000	\$50,000
4.7	Condensate Recovery	0	LS	\$20,000	\$0
4.8	Underground Utility Protection	1	LS	\$25,000	\$25,000
4.9	Construction Oversight (Supervisor, QC/H&S, Geologist)	2	Month	\$60,000	\$120,000
4.10	Craft Labor (2 People)	2	Month	\$32,000	\$64,000
	Subtotal (Item 4)				\$439,400

5.	Product Recovery				
5.1	6" Product Recovery Wells (5 at 60 feet)	300	LF	\$100	\$30,000
5.2	Product Recovery Piping	165	LF	\$50	\$8,250
5.3	Piping Misc.	1	LS	\$20,000	\$20,000
5.4	Vacuum Recovery System (Tank and Blower)	1	LS	\$50,000	\$50,000
5.5	Pump to Oil Water Separator (2 gpm)	1	LS	\$10,000	\$10,000
5.6	Oil Water Separator w/ Secondary Containment	1	LS	\$30,000	\$30,000
5.7	Water Treatment System	1	LS	\$30,000	\$30,000
5.8	Air Treatment	1	LS	\$15,000	\$15,000
5.9	Power and controls	1	LS	\$10,000	\$10,000
5.10	Construction Oversight (Supervisor, QC/H&S, Geologist)	1	Month	\$60,000	\$60,000
5.11	Craft Labor (2 People)	1	Month	\$32,000	\$32,000
	Subtotal (Item 5)				\$295,250
6.	Construction Completion Report/O&M Manual	1	LS	\$30,000	\$30,000
7.	System Removal and Disposal	1	LS	\$100,000	\$100,000
	Contingency (20%)				\$271,730
	Design & Engineering (13%)				\$176,625
	Total Construction Cost				\$1,807,005

Annual O&M Cost (3)

Item	Description	Quantity	Units	Unit Cost	Extended Cost
1.	5-Year Review/LUCs	1	Each	\$30,000	\$30,000
2	GW sampling, analysis, and reporting				
2.1	Laboratory Analysis (VOCs, SVOCs, and Metals)	11	Each	\$400	\$4,400
2.2	Field Labor	4	Day	\$1,200	\$4,800
2.3	Annual Reporting	1	Each	\$20,000	\$20,000
	Contingency (20%)				\$5,840
	Subtotal (Item 2)				\$35,040
3.	Soil sampling, analysis, and reporting				
3.1	Laboratory Analysis (TPH and PAHs)	20	Each	\$200	\$4,000
3.2	Field Labor	4	day	\$1,200	\$4,800
3.3	Drilling/Split Spoon to 70 ft (4 borings)	4	each	\$3,500	\$14,000
3.4	Reporting	1	Each	\$20,000	\$20,000
	Contingency (20%)				\$8,560
	Subtotal (Item 3)				\$51,360
4.	Steam Injection				
4.1	Water	12	Month	\$150	\$1,800.00
4.2	Electrical (Steam: 15 kw, Blowers, Other: 5 KW)	175,200	KW-Hrs	\$0.18	\$31,536
4.3	System Maintenance	1	LS	\$6,000	\$6,000
4.4	Operator (1 day per week)	52	day	\$750	\$39,000
	Contingency (20%)				\$15,667
	Subtotal (Item 4)				\$94,003
5.	Product Recovery				
5.1	Electrical (30 KW - 40 hours per month)	14400	KW-Hrs	\$0.18	\$2,592
5.2	System Maintenance	1	LS	\$2,400	\$2,400
5.3	Product Transportation and Disposal	2,275	Gallons	\$3	\$6,825
5.4	GAC Treatment	5,000	lb	\$3	\$15,000
5.5	Water and Air monitoring	12	month	\$2,500	\$30,000
5.6	Operator (4 days per month)	48	days	\$750	\$36,000
	Contingency (20%)				\$18,563
	Subtotal (Item 5)				\$111,380
6.	O&M Reporting and Management	1	Each	\$30,000	\$30,000

Cost Summary (without discount factor).

	Capital	O&M	Duration (year)	Total Cost	
1	Baseline and Annual GW Sampling, and analysis	\$59,200	\$35,040	16	\$619,840
2	General Mobilization/Demobilization	\$94,800	\$0	1	\$94,800
3	Building & Utilities	\$340,000	\$0	1	\$340,000
2	Steam Injection	\$439,400	\$94,003	4	\$815,413
3	Product Recovery	\$295,250	\$111,380	4	\$740,772
4	Construction Completion Report	\$30,000	\$0	1	\$30,000
5	Capital Cost Contingency (20%)	\$271,730	\$0	1	\$271,730.00
6	Design & Engineering (13%)	\$176,625	\$0	1	\$176,625
7	5-Year Review/LUCs	\$0	\$30,000	4	\$120,000
8	Soil sampling, analysis, and reporting	\$0	\$51,360	2	\$102,720
9	O&M Reporting and Management	\$0	\$30,000	4	\$120,000
10	System Removal	\$100,000		1	\$100,000
	Total Alternative 3	\$1,807,005			\$3,531,899

Present Value Calculation (32 years) (3)

As of	Dec-13	interest rate (OBM)	2.00%	
	Cost	NPW	DF	
2013	\$ 1,807,005	\$ 1,807,005		
2014	\$ 300,424	294,533	0.980	
2015	\$ 270,424	259,923	0.961	
2016	\$ 270,424	254,826	0.942	
2017	\$ 321,784	297,278	0.924	
2018	\$ 35,040	31,737	0.906	
2019	\$ 65,040	57,754	0.888	
2020	\$ 35,040	30,504	0.871	
2021	\$ 35,040	29,906	0.853	
2022	\$ 35,040	29,320	0.837	
2023	\$ 35,040	28,745	0.820	
2024	\$ 65,040	52,309	0.804	
2025	\$ 35,040	27,629	0.788	
2026	\$ 86,400	66,790	0.773	
2027	\$ 35,040	26,556	0.758	
2028	\$ 35,040	26,035	0.743	
2029	\$ 65,040	47,378	0.728	
2030	\$ -	-	0.714	
2031	\$ -	-	0.700	
2032	\$ -	-	0.686	
2033	\$ -	-	0.673	
2034	\$ -	-	0.660	
2035	\$ -	-	0.647	
2036	\$ -	-	0.634	
2037	\$ -	-	0.622	
2038	\$ -	-	0.610	
2039	\$ -	-	0.598	
2040	\$ -	-	0.586	
2041	\$ -	-	0.574	
2042	\$ -	-	0.563	
2043	\$ -	-	0.552	
2044	\$ -	-	0.541	
2045	\$ -	-	0.531	
	\$ 3,531,899	\$ 3,368,228	\$ 23	

Alternative 4 - Biosparge Treatment with Limited Free Product Recovery

Capital Cost

Item	Description	Quantity	Units	Unit Cost	Extended Cost
1.	Baseline GW Sampling, analysis and reporting				
1.1	Laboratory Analysis (VOCs, SVOCs, and Metals)	11	Each	\$400	\$4,400
1.2	Field Labor	4	Day	\$1,200	\$4,800
1.3	UPF-SAP/Work Plan for long term monitoring	1	Each	\$30,000	\$30,000
1.4	Reporting	1	Each	\$20,000	\$20,000
	Subtotal (Item 1)				\$59,200
2.	General Mobilization/Demobilization				
2.1	Construction Facilities (trailer, utilities) - 6 months	6	month	\$2,000	\$12,000
2.2	Decon Pad Construction	1	LS	\$800	\$800
2.3	Utility Clearance	1	LS	\$2,000	\$2,000
2.4	Construction Oversight & Start-Up (Supervisor, QC/H&S, Geologist)	2	Month	\$40,000	\$80,000
	Subtotal (Item 2)				\$94,800
3.	Building Utilities				
3.1	Building	600	SQ FT	\$300	\$180,000
3.2	Water Supply	1	Each	\$20,000	\$20,000
3.3	Sewer Connection	1	Each	\$10,000	\$10,000
3.4	Electricity Connection	1	Each	\$50,000	\$50,000
3.5	Construction Oversight Start-Up (Supervisor, QC/H&S)	2	Month	\$40,000	\$80,000
	Subtotal (Item 4)				\$340,000
4.	Air Injection				
4.1	Air Injection Wells (1 inch diameter) 14 at 70 ft	980	FT	\$80	\$78,400
4.2	Air Injection Piping (1 inch steel)	100	FT	\$50	\$5,000
4.3	Piping Misc	1	LS	\$10,000	\$10,000
4.4	Blower	1	Each	\$15,000	\$15,000
4.5	Power and controls	1	LS	\$25,000	\$25,000
4.6	Construction Oversight (Supervisor, QC/H&S, Geologist)	1	Month	\$60,000	\$60,000
4.7	Craft Labor	1	Month	\$32,000	\$32,000
	Subtotal (Item 4)				\$225,400
5.	Limited Steam Injection				
5.1	Steam Injection Wells (1 inch diameter) 6 at 50 ft	300	FT	\$80	\$24,000
5.2	Steam Generator/blowdown pump	1	LS	\$14,000	\$14,000
5.3	Water Supply Connection	1	LS	\$5,000	\$5,000
5.4	Steam Injection Piping - (1 inch steel - underground)	180	FT	\$50	\$9,000
5.5	Piping Misc.	1	LS	\$15,000	\$15,000
5.6	Power and Controls	1	LS	\$50,000	\$50,000
5.7	Condensate Recovery	0	LS	\$20,000	\$0
5.8	Underground Utility Protection	1	LS	\$20,000	\$20,000
5.9	Construction Oversight (Supervisor, QC/H&S, Geologist)	1	Month	\$60,000	\$60,000
5.10	Craft Labor	1	Month	\$32,000	\$32,000
	Subtotal (Item 5)				\$229,000

6.	Free Product Recovery				
6.1	Product Recovery Well (6 inch diameter) 1 at 60 ft	60	FT	\$100	\$6,000
6.2	Product Recovery Piping	80	LF	\$50	\$4,000
6.3	Piping Misc.	1	LS	\$20,000	\$20,000
6.4	Vacuum Recovery System (Tank and Blower)	1	LS	\$45,000	\$45,000
6.5	Pump to Oil Water Separator (2 gpm)	1	LS	\$10,000	\$10,000
6.6	Oil Water Separator w/ Secondary Containment	1	LS	\$30,000	\$30,000
6.7	Water Treatment System	1	LS	\$30,000	\$30,000
6.8	Air Treatment	1	LS	\$15,000	\$15,000
6.9	Power and controls	1	LS	\$10,000	\$10,000
6.10	Construction Oversight (Supervisor, QC/H&S)	1	Month	\$40,000	\$40,000
6.11	Craft Labor	1	Month	\$32,000	\$32,000
	Subtotal (Item 6)				\$242,000
7.	Construction Completion Report/O&M Manual	1	LS	\$30,000	\$30,000
8.	System Removal and Disposal	1	LS	\$100,000	\$100,000
	Contingency (20%)				\$264,080
	Design & Engineering (13%)				\$171,652
	Total Construction Cost				\$1,756,132

Annual O&M Cost (4)

Item	Description	Quantity	Units	Unit Cost	Extended Cost
1.	5-Year Review/LUCs	1	Each	\$30,000	\$30,000
2.	GW Sampling, Analysis, and Reporting				
2.1	Laboratory Analysis (VOCs, SVOCs, and Metals)	11	Each	\$400	\$4,400
2.2	Field Labor	4	Day	\$1,200	\$4,800
2.3	Annual Reporting	1	Each	\$20,000	\$20,000
	Contingency (20%)				\$5,840
	Subtotal (Item 2)				\$35,040
3.	Soil Sampling, Analysis, and Reporting				
3.1	Laboratory Analysis (TPH and PAHs)	20	Each	\$200	\$4,000
3.2	Field Labor	4	Day	\$1,200	\$4,800
3.3	Drilling/Split Spoon to 70 ft (4 borings)	4	each	\$3,500	\$14,000
3.4	Reporting	1	Each	\$20,000	\$20,000
	Contingency (20%)				\$8,560
	Subtotal (Item 3)				\$51,360
4.	Air Injection				
4.1	Electrical (4 kw, 2 other)	52560	KW-Hrs	\$0.18	\$9,461
4.2	System Maintenance	1	LS	\$3,200	\$3,200
4.3	Operator	26	days	\$750	\$19,500
	Contingency (20%)				\$6,432
	Subtotal (Item 4)				\$38,593
5.	Limited Steam Injection				
5.1	Water	12	Month	\$120	\$1,440
5.2	Electrical (Steam 9 KW, 2 other)	96360	KW-Hrs	\$0.18	\$17,345
5.3	System Maintenance	1	LS	\$6,000	\$6,000
5.4	Operator	52	day	\$750	\$39,000
5.5	Contingency (20%)				\$12,757
	Subtotal (Item 5)				\$76,542
6.	Limited Free Product Recovery				
6.1	Electrical (30 KW 40 hours per month)	14400	KW-Hrs	\$0.18	\$2,592
6.2	System Maintenance	1	LS	\$2,400	\$2,400
6.3	Product Transportation and Disposal	3,950	Gallons	\$3	\$11,850
6.4	GAC Treatment	5,000	lb	\$3	\$15,000
6.5	Water and Air monitoring	12	month	\$2,500	\$30,000
6.6	Operator (4 days per month)	48	day	\$750	\$36,000
6.7	Contingency (20%)				\$19,568
	Subtotal (Item 6)				\$117,410
7.	O&M Reporting and Management	1	Each	\$30,000	\$30,000
					\$0

Cost Summary (without discount factor).

	Capital	O&M	Duration (year)	Total Cost	
1	Baseline and Annual GW Sampling, analysis and reporting	\$59,200	\$35,040	10	\$409,600
2	General Mobilization/Demobilization	\$94,800	\$0	1	\$94,800
3	Building Utilities	\$340,000	\$0	1	\$340,000
4	Air Injection	\$225,400	\$38,593	4	\$379,772
5	Limited Steam Injection	\$229,000	\$76,542	2	\$382,084
6	Limited Free Product Recovery	\$242,000	\$117,410	2	\$476,821
7	Construction Completion Report/O&M Manual	\$30,000	\$0	1	\$30,000
8	Contingency (20%)	\$264,080	\$0	1	\$264,080
9	Design & Engineering (13%)	\$171,652	\$0	1	\$171,652
10	5-Year Review/LUCs	\$0	\$30,000	3	\$90,000
11	Soil Sampling, Analysis, and Reporting	\$0	\$51,360	2	\$102,720
12	O&M Reporting and Management	\$0	\$30,000	4	\$120,000
13	System Removal	\$100,000		1	\$100,000
	Total Alternative 4	\$1,756,132			\$2,961,528

Present Value Calculation

As of	Dec-13	interest rate (OBM)	2.00%	
	Cost	NPW	DF	
2013	\$ 1,756,132	\$ 1,756,132		
2014	\$ 327,585	321,162	0.980	
2015	\$ 348,945	335,395	0.961	
2016	\$ 103,633	97,656	0.942	
2017	\$ 154,993	143,190	0.924	
2018	\$ 35,040	31,737	0.906	
2019	\$ 65,040	57,754	0.888	
2020	\$ 35,040	30,504	0.871	
2021	\$ 35,040	29,906	0.853	
2022	\$ 35,040	29,320	0.837	
2023	\$ 35,040	28,745	0.820	
2024	\$ 30,000	24,128	0.804	
2025	\$ -	-		
2026	\$ -	-		
	\$ -	-		
	\$ -	-		
	\$ 2,961,528	\$ 2,885,628	\$	10

Alternative 5 - Solvent Extraction and Biosparging

Capital Cost

Item	Description	Quantity	Units	Unit Cost	Extended Cost
1.	Baseline GW Sampling, analysis and reporting				
1.1	Laboratory Analysis (VOCs, SVOCs, and Metals)	11	Each	\$400	\$4,400
1.2	Field Labor	4	Day	\$1,200	\$4,800
1.3	UPF-SAP/Work Plan for long term monitoring	1	Each	\$30,000	\$30,000
1.4	Annual Reporting	1	Each	\$20,000	\$20,000
	Subtotal (Item 1)				\$59,200
2.	General Mobilization/Demobilization				
2.1	Construction Facilities (trailer, utilities) - 6 months	6	month	\$2,000	\$12,000
2.2	Decon Pad Construction	1	LS	\$800	\$800
2.3	Utility Clearance	1	LS	\$2,000	\$2,000
2.4	Construction Oversight & Start-Up (Supervisor, QC/H&S)	2	Month	\$40,000	\$80,000
	Subtotal (Item 2)				\$94,800
3	Building Utilities				
3.1	Building	160	SQ FT	\$300	\$48,000
3.2	Water Supply	1	Each	\$20,000	\$20,000
3.3	Sewer Connection	1	Each	\$10,000	\$10,000
3.4	Electricity Connection	1	Each	\$50,000	\$50,000
3.5	Construction Oversight Start-Up (Supervisor, QC/H&S, Geologist)	2	Month	\$40,000	\$80,000
	Subtotal (Item 3)				\$208,000
4	Solvent Injection				
4.1	Deep Injection Wells (12 at 70 ft and 32 at 20 ft)	1,960	FT	\$65	\$127,400
4.2	Piping	700	FT	\$25	\$17,500
4.3	Piping Misc	1	LS	\$10,000	\$10,000
4.4	Solvent (Vertec)	20,000	Gallon	\$5.00	\$100,000
4.5	Construction Oversight (Supervisor, QC/H&S, Geologist)	2	Month	\$60,000	\$120,000
4.6	Craft Labor	2	Month	\$32,000	\$64,000
	Subtotal (Item 4)				\$438,900
5	Product/Solvent Extraction				
5.1	Product Recovery Wells (5 at 60 ft)	300	FT	\$65	\$19,500
5.2	Product Recovery Pumps	5	Each	\$2,500	\$12,500
5.3	Piping	180	FT	\$25	\$4,500
5.4	Piping Misc	1	LS	\$10,000	\$10,000
5.5	Raw/Waste Oil Tank (10,000 gal)	2	Each	\$50,000	\$100,000
5.6	Power and Controls	1	LS	\$20,000	\$20,000
5.8	Construction Oversight (Supervisor, QC/H&S)	1	Month	\$40,000	\$40,000
5.9	Craft Labor	1	Month	\$32,000	\$32,000
	Subtotal (Item 5)				\$238,500

6	Biosparge				
6.1	Blower	1	Each	\$15,000	\$15,000
6.2	Piping Misc	1	LS	\$5,000	\$5,000
6.3	Power and Controls	1	LS	\$15,000	\$15,000
6.4	Construction Oversight (Supervisor, QC/H&S)	0.5	Month	\$40,000	\$20,000
6.4	Craft Labor	0.5	Month	\$32,000	\$16,000
	Subtotal (Item 6)				\$71,000
7.	System Removal and Disposal	1	Each	\$100,000	\$100,000
	Contingency (20%)				\$242,080
	Design & Engineering (13%)				\$157,352
	Total Construction Cost				\$1,609,832

Annual O&M Cost (5)

Item	Description	Quantity	Units	Unit Cost	Extended Cost
1.	5-Year Review/LUCs	1	Each	\$30,000	\$30,000
2.	GW Sampling, Analysis, and Reporting				
2.1	Laboratory Analysis (VOCs, SVOCs, and Metals)	11	Each	\$400	\$4,400
2.2	Field Labor	4	Day	\$1,200	\$4,800
2.3	Annual Reporting	1	Each	\$20,000	\$20,000
2.4	Contingency (20%)				\$5,840
	Subtotal (Item 2)				\$35,040
3.	Soil Sampling, Analysis, and Reporting				
3.1	Laboratory Analysis (TPH and PAHs)	20	Each	\$200	\$4,000
3.2	Field Labor	4	Day	\$1,200	\$4,800
3.3	Drilling/Split Spoon to 70 ft (4 borings)	4	Each	\$3,500	\$14,000
3.4	Reporting	1	Each	\$20,000	\$20,000
3.5	Contingency (20%)				\$8,560
	Subtotal (Item 3)				\$51,360
4.	Solvent Injection/Extraction				
4.1	Electrical	6	Month	\$500	\$3,000
4.2	Fresh Solvent(Per year)	50,000	Gallon	\$5	\$250,000
4.2	Solvent/Product Transportation and Disposal (Per year)	55,000	Gallon	\$3	\$165,000
4.3	Operator (40 weeks per year)	200	day	\$750	\$150,000
4.4	Contingency (20%)				\$113,600
	Subtotal (Item 4)				\$681,600
5.	Biosparge				
5.1	Electrical (3 kw, 2 other)	43800	KW-Hrs	\$0.18	\$7,884
5.2	System Maintenance	1	LS	\$5,000	\$5,000
5.4	Operator	26	day	\$750	\$19,500
	Contingency (20%)				\$6,477
	Subtotal (Item 5)				\$38,861
6.	O&M Reporting and Management	1	Each	\$30,000	\$30,000

Cost Summary (without discount factor).

	Capital	O&M	Duration (year)	Total Cost	
1	Baseline GW Sampling, analysis and reporting	\$59,200	\$35,040	10	\$409,600
2	General Mobilization/Demobilization	\$94,800	\$0	1	\$94,800
3	Building Utilities	\$208,000	\$0	1	\$208,000
4	Solvent Injection	\$438,900	\$0	2	\$438,900
5	Product/Solvent Extraction	\$238,500	\$681,600	2	\$1,601,700
6	Biosparge	\$71,000	\$38,861	4	\$226,443
7	Contingency (20%)	\$242,080	\$0	1	\$242,080
8	Design & Engineering (13%)	\$157,352	\$0	1	\$157,352
9	5-Year Review/LUCs	\$0	\$30,000	3	\$90,000
10	Soil Sampling, Analysis, and Reporting	\$0	\$51,360	2	\$102,720
11	O&M Reporting and Management	\$0	\$30,000	4	\$120,000
12	System Removal	\$100,000		1	\$100,000
	Total Alternative 5	\$1,609,832			\$3,791,595

Present Value Calculation

As of	Dec-13	interest rate (OBM)	2.00%	
	Cost	NPW	DF	
2013	\$ 1,609,832	\$ 1,609,832		
2014	\$ 815,501	799,511	0.980	
2015	\$ 785,501	754,999	0.961	
2016	\$ 73,901	69,638	0.942	
2017	\$ 155,261	143,437	0.924	
2018	\$ 65,040	58,909	0.906	
2019	\$ 65,040	57,754	0.888	
2020	\$ 35,040	30,504	0.871	
2021	\$ 35,040	29,906	0.853	
2022	\$ 35,040	29,320	0.837	
2023	\$ 35,040	28,745	0.820	
2024	\$ 81,360	65,435	0.804	
2025	\$ -	-	0.788	
2026	\$ -	-	0.773	
2027	\$ -	-	0.758	
	\$ -			
	\$ 3,791,595	\$ 3,677,990	\$	12

Alternative 6A - Excavation >1,000 mg/kg Soils

Capital Cost

Item	Description	Quantity	Units	Unit Cost	Extended Cost
1.	Baseline GW Sampling, analysis and reporting				
1.1	Laboratory Analysis (VOCs, SVOCs, and Metals)	11	Each	\$400	\$4,400
1.2	Field Labor	4	Day	\$1,200	\$4,800
1.3	UPF-SAP/Work Plan for long term monitoring	1	Each	\$30,000	\$30,000
1.4	Reporting	1	Each	\$20,000	\$20,000
	Subtotal (Item 1)				\$59,200
2.	Site Delineation				
2.1	Drilling/Split Spoon	30	Each	\$2,500	\$75,000
2.2	Decon Pad Construction	1	Each	\$2,000	\$2,000
2.3	Laboratory Analysis (TPH and PAHs)	240	Each	\$200	\$48,000
2.5	Geologist	20	Day	\$1,200	\$24,000
2.6	Reporting/Work Plan	1	LS	\$30,000	\$30,000
	Subtotal (Item 2)				\$179,000
3.	Waste-Characterization				
3.1	Drilling/Split Spoon	0	Each	\$2,000	\$0
3.2	Decon Pad Construction	0	Each	\$800	\$0
3.3	Pre-characterization Analysis (TCLP)	14	Each	\$700	\$9,800
3.4	Monitoring Well Removal	2	Each	\$300	\$600
3.5	Geologist	0	Day	\$1,200	\$0
	Subtotal (Item 3)				\$10,400
4.	General Mobilization/Demobilization				
4.1	Construction Facilities (trailer, utilities)	18	month	\$3,000	\$54,000
4.2	Utility Clearance	1	LS	\$3,000	\$3,000
4.3	Site Prep (high vis fence, traffic control, E&S controls)	10	days	\$2,000	\$20,000
4.4	Construction Entrance	10	days	\$2,000	\$20,000
4.5	Material staging area (10 ml poly/hay bales 160 ft X 120 ft)	6	Areas	\$8,400	\$50,400
4.6	Construction Oversight (Supervisor, QC/H&S)	2	Month	\$40,000	\$80,000
4.7	Heavy Equipment mob/demob	6	Each	\$6,000	\$36,000
	Subtotal (Item 4)				\$263,400

5.	Excavation				
5.1	Asphalt Removal and Disposal (560 Sq Yds)	1	Month	\$15,000	\$15,000
5.2	Sheet Pile Drive and Equipment	21,000	CY	\$75	\$1,575,000
5.3	Excavation (21,000 Cu Yds) - Inhole & Lift	10	Month	\$44,000	\$440,000
5.4	Management of Reuse Soil (14,000 Cu Yds)	12	Month	\$66,000	\$792,000
5.5	Load, Transport, and Dispose	10,500	Tons	\$85	\$892,500
5.6	Confirmation Sampling	23	Each	\$210	\$4,830
5.7	De-Watering/Treatment and Discharge to Basins	6	Month	\$25,000	\$150,000
5.8	Product (handling and disposal)	1	LS	\$10,000	\$10,000
5.9	Misc Construction Supplies	24	Month	\$500	\$12,000
5.10	Concrete UST Pad Removal and Disposal	46	CU YDs	\$50	\$2,300
5.11	Backfill of Soils for Reuse (14,000 Cu Yds)	2	Month	\$51,000	\$102,000
5.12	Backfill (off-site Source)	10,500	Tons	\$30	\$315,000
5.13	Fuel (500 gallons a week)	35,000	Gallons	\$4	\$140,000
5.14	Construction Oversight (Supervisor, QC/H&S)	16	Month	\$40,000	\$640,000
	Subtotal (Item 5)				\$5,090,630
6.	Site Restoration				
6.1	Top Soil	60	CU YDs	\$30	\$1,800
6.2	Grading	0.5	Month	\$18,000	\$9,000
6.3	Stone/Asphalt	560	SQ YDs	\$15	\$8,400
6.4	Seeding	1	LS	\$5,000	\$5,000
6.5	Material Staging Area Removal	1	Month	\$18,000	\$18,000
6.6	Decon of Equipment	6	Each	\$5,000	\$30,000
6.7	General Construction Debris Removal	1	LS	\$10,000	\$10,000
6.8	Monitoring Well Installation (Geologist)	2	Each	\$5,000	\$10,000
6.9	Construction Oversight (Supervisor, QC/H&S)	2	Month	\$60,000	\$120,000
	Subtotal (Item 6)				\$212,200
7.	Construction Close Out Reporting	1	LS	\$50,000	\$50,000
	Contingency (20%)				\$1,172,966
	Design & Engineering (13%)				\$762,428
	Total Construction Cost				\$7,800,224

Annual O&M Cost (6A)

Item	Description	Quantity	Units	Unit Cost	Extended Cost
1.	5-Year Review/LUCs	1	Each	\$30,000	\$30,000
2.	GW Sampling, Analysis, and Reporting				
2.1	Laboratory Analysis (VOCs, SVOCs, and Metals)	11	Each	\$400	\$4,400
2.2	Field Labor	4	Day	\$1,200	\$4,800
2.3	Annual Reporting	1	Each	\$20,000	\$20,000
2.4	Contingency (20%)				\$5,840
	Subtotal (Item 2)				\$35,040

Cost Summary (without discount factor).

		Capital	O&M	Duration (year)	Total Cost
1	GW Sampling, analysis and reporting	\$59,200	\$35,040	4	\$199,360
2	Site Delineation	\$179,000	\$0	1	\$179,000
3	Pre-Characterization	\$10,400	\$0	1	\$10,400
4	General Mobilization/Demobilization	\$263,400	\$0	1	\$263,400
5	Excavation	\$5,090,630	\$0	1	\$5,090,630
6	Site Restoration	\$212,200	\$0	1	\$212,200
7	Construction Close Out Reporting	\$50,000	\$0	1	\$50,000
8	Contingency (20%)	\$1,172,966	\$0	1	\$1,172,966
9	Design & Engineering (13%)	\$762,428	\$0	1	\$762,427.90
10	5-Year Review/LUCs	\$0	\$30,000	1	\$30,000
	Total Alternative 6A	\$7,800,224			\$7,970,384

Present Value Calculation

	Cost	NPW	DF
As of Dec-13			
interest rate (OBM)		2.00%	
2013	\$ 7,800,224	\$ 7,800,224	
2014	\$ 35,040	34,353	0.980
2015	\$ 35,040	33,679	0.961
2016	\$ 35,040	33,019	0.942
2017	\$ 65,040	60,087	0.924
2018	\$ -	-	0.906
2019	\$ -	-	0.888
2020	\$ -	-	0.871
	\$ 7,970,384	\$ 7,961,362	

Alternative 6B - Excavation Of >10,000 mg/kg Soils

Capital Cost

Item	Description	Quantity	Units	Unit Cost	Extended Cost
1.	Baseline GW Sampling, analysis and reporting				
1.1	Laboratory Analysis (VOCs, SVOCs, and Metals)	11	Each	\$400	\$4,400
1.2	Field Labor	4	Day	\$1,200	\$4,800
1.3	UPF-SAP/Work Plan for long term monitoring	1	Each	\$30,000	\$30,000
1.4	Reporting	1	Each	\$20,000	\$20,000
	Subtotal (Item 1)				\$59,200
2.	Site Delineation				
2.1	Drilling/Split Spoon	30	Each	\$2,500	\$75,000
2.2	Decon Pad Construction	1	Each	\$2,000	\$2,000
2.3	Laboratory Analysis (TPH and PAHs)	240	Each	\$200	\$48,000
2.5	Geologist	20	Day	\$1,200	\$24,000
2.6	Reporting/Work Plan	1	LS	\$30,000	\$30,000
	Subtotal (Item 2)				\$179,000
3.	Waste-Characterization				
3.1	Drilling/Split Spoon	0	Each	\$2,000	\$0
3.2	Decon Pad Construction	0	Each	\$800	\$0
3.3	Pre-characterization Analysis (TCLP)	14	Each	\$700	\$9,800
3.4	Monitoring Well Removal	2	Each	\$300	\$600
3.5	Geologist	0	Day	\$1,200	\$0
	Subtotal (Item 3)				\$10,400
4.	General Mobilization/Demobilization				
4.1	Construction Facilities (trailer, utilities)	10	month	\$3,000	\$30,000
4.2	Utility Clearance	1	LS	\$3,000	\$3,000
4.3	Site Prep (high vis fence, traffic control, E&S controls)	10	Day	\$2,000	\$20,000
4.4	Construction Entrance	10	Day	\$4,000	\$40,000
4.5	Material staging area (10 ml poly/hay bales)	4	Areas	\$8,400	\$33,600
4.6	Construction Oversight (Supervisor, QC/H&S)	2	Month	\$40,000	\$80,000
4.7	Heavy Equipment mob/demob	6	Each	\$6,000	\$36,000
	Subtotal (Item 4)				\$242,600

5.	Excavation				
5.1	Asphalt Removal and Disposal (260 Sq Yds)	1	Month	\$15,000	\$15,000
5.2	Sheet Pile Drive and Equipment	8,000	CY	\$75	\$600,000
5.3	Excavation (8,000 Cu Yds) - Inhole and Lift	4	Month	\$44,000	\$176,000
5.4	Staging of Soils for Reuse (1400 Cu Yds)	6	Month	\$66,000	\$396,000
5.5	Load, Transport, and Dispose	2,100	Tons	\$85	\$178,500
5.6	Confirmation Sampling (composite every 100 ft)	23	Each	\$210	\$4,830
5.7	De-Watering/Treatment and Discharge to Basins	4	Month	\$25,000	\$100,000
5.8	Product (handling and disposal)	1	LS	\$10,000	\$10,000
5.9	Misc Construction Supplies	14	Month	\$500	\$7,000
5.10	Concrete UST Pad Removal and Disposal	46	CU YDs	\$50	\$2,300
5.11	Backfill of Soils for Reuse (6,600 Cu Yds)	1	Month	\$51,000	\$51,000
5.12	Backfill (off-site Source)	10,500	Tons	\$30	\$315,000
5.13	Fuel (500 gallons a week)	20,000	Gallons	\$4	\$80,000
5.14	Construction Oversight (Supervisor, QC/H&S)	10	Month	\$40,000	\$400,000
	Subtotal (Item 5)				\$2,335,630
6.	Site Restoration				
6.1	Top Soil	30	CU YDs	\$30	\$900
6.2	Grading	0.5	Month	\$18,000	\$9,000
6.3	Stone/Asphalt	260	SQ YDs	\$15	\$3,900
6.4	Seeding	1	LS	\$5,000	\$5,000
6.5	Material Staging Area Removal	1	Month	\$18,000	\$18,000
6.6	Decon of Equipment	6	Each	\$5,000	\$30,000
6.7	General Construction Debris Removal	1	LS	\$10,000	\$10,000
6.8	Monitoring Well Installation (Geologist)	2	Each	\$5,000	\$10,000
6.9	Construction Oversight (Supervisor, QC/H&S)	2	Month	\$60,000	\$120,000
	Subtotal (Item 6)				\$206,800
7.	Construction Close Out Reporting	1	LS	\$50,000	\$50,000
	Contingency (20%)				\$616,726
	Design & Engineering (13%)				\$400,872
	Total Construction Cost				\$4,101,228

Annual O&M Cost (6B)

Item	Description	Quantity	Units	Unit Cost	Extended Cost
1.	5-Year Review/LUCs	1	Each	\$30,000	\$30,000
2.	GW Sampling, Analysis, and Reporting				
2.1	Laboratory Analysis (VOCs, SVOCs, and Metals)	11	Each	\$400	\$4,400
2.2	Field Labor	4	Day	\$1,200	\$4,800
2.3	Annual Reporting	1	Each	\$20,000	\$20,000
2.4	Contingency (20%)				\$5,840
	Subtotal (Item 2)				\$35,040

Cost Summary (without discount factor).

		Capital	O&M	Duration (year)	Total Cost
1	GW Sampling, analysis and reporting	\$59,200	\$35,040	12	\$479,680
2	Site Delineation	\$179,000	\$0	1	\$179,000
3	Pre-Characterization	\$10,400	\$0	1	\$10,400
4	General Mobilization/Demobilization	\$242,600	\$0	1	\$242,600
5	Excavation	\$2,335,630	\$0	1	\$2,335,630
6	Site Restoration	\$206,800	\$0	1	\$206,800
7	Construction Close Out Reporting	\$50,000	\$0	1	\$50,000
8	Contingency (20%)	\$616,726	\$0	1	\$616,726
9	Design & Engineering (13%)	\$400,872	\$0	1	\$400,872
10	5-Year Review/LUCs	\$0	\$30,000	3	\$90,000
	Total Alternative 6B	\$4,101,228			\$4,611,708

Present Value Calculation

	Dec-12			
As of	interest rate (OBM)		2.00%	
	Cost	NPW	DF	
2013	\$ 4,101,228	\$ 4,101,228		
2014	\$ 35,040	34,353	0.980	
2015	\$ 35,040	33,679	0.961	
2016	\$ 65,040	61,289	0.942	
2017	\$ 35,040	32,372	0.924	
2018	\$ 35,040	31,737	0.906	
2019	\$ 35,040	31,115	0.888	
2020	\$ 35,040	30,504	0.871	
2021	\$ 65,040	55,511	0.853	
2022	\$ 35,040	29,320	0.837	
2023	\$ 35,040	28,745	0.820	
2024	\$ 35,040	28,181	0.804	
2025	\$ 35,040	27,629	0.788	
2026	\$ 30,000	23,191	0.773	
	\$ 4,611,708	\$ 4,548,853	\$	11

APPENDIX E ENVIRONMENTAL FOOTPRINT EVALUATION

APPENDIX E-1 ENVIRONMENTAL FOOTPRINT REPORT

APPENDIX E

Environmental Footprint Evaluation Feasibility Study/Corrective Measures Study Site 4 (Area of Concern 22) – Former Underground Storage Tanks Naval Weapons Industrial Reserve Plant Bethpage, New York January 2013

OBJECTIVE

This Environmental Footprint Evaluation of remedial alternatives is provided as an Appendix to the Feasibility Study (FS)/Corrective Measures Study for Site 4 (Area of Concern 22) – Former Underground Storage Tanks located at the Naval Weapons Industrial Reserve Plant located in Bethpage, NY. The purpose of the footprint evaluation is to assess the environmental impacts of the six remedial alternatives using the metrics of greenhouse gas (GHG) and criteria pollutant emissions, energy use, water consumption, and worker safety. The results of this footprint evaluation are intended to provide additional information for consideration during remedy selection, design, and to enhance the understanding of the environmental impacts throughout the remedy life-cycle for each of the proposed alternatives.

POLICY BACKGROUND

Department of Defense (DOD) and Navy policies require continual optimization of remedies in every phase from remedy selection through site closeout (NAVFAC, 2010a).

In January 2007, Executive Order 13423 set targets for sustainable practices for (i) energy efficiency, greenhouse gas emissions avoidance or reduction, and petroleum products use reduction, (ii) renewable energy, including bioenergy, (iii) water conservation, (iv) acquisition, (v) pollution and waste prevention and recycling, etc. In October 2009, Executive Order 13514 was issued, which reinforced these sustainability requirements and established specific goals for federal agencies to meet by 2020.

In August 2009 DOD issued a policy for “Consideration of Green and Sustainable Remediation Practices in the Defense Environmental Restoration Program.” The DOD policy and related Navy guidance state that opportunities to increase sustainability should be considered throughout all phases of remediation (i.e., site investigation, remedy selection, remedy design and construction, operation, monitoring, and site closeout). In response to this policy, the Department of the Navy (DON) issued an updated Navy

Guidance for “Optimizing Remedy Evaluation, Selection, and Design” (NAVFAC, 2010), which includes environmental footprint evaluations as part of the traditional DON optimization review process for remedy selection, design, and remedial action operation. In August 2010, the Naval Facilities Engineering Command (NAVFAC) issued policy requiring use of the SiteWise™ tool to perform environmental impact reviews as part of all Feasibility Studies. As such, this environmental footprint evaluation of remedial alternatives is being performed to estimate the environmental footprint associated with each alternative in the interest of reducing the environmental impact of remedial action at the Naval Weapons Industrial Reserve Plant.

Applying the DON optimization concepts with an environmental footprint evaluation within the remedy selection and design phases allows for the following benefits:

- Determining factors in each remedial alternative with the greatest environmental impacts and gathering insight into how to reduce these impacts;
- Evaluating remedial alternatives with optimized or reduced environmental footprints in conjunction with other selection criteria;
- Designing and implementing a more robust remedy while balancing the impact to the environment; and
- Ensuring efficient, cost-effective and sustainable site closeout.

EVALUATION TOOLS

This evaluation was performed using a hybrid model of the Navy’s SiteWise™ tool supplemented with Tetra Tech developed model as appropriate for some site-specific items.

SiteWise™ is a life-cycle footprint assessment tool developed jointly by the U.S. Navy, U.S. Army Corps of Engineers (USACE), and Battelle. SiteWise™ assesses the environmental footprint of a remedial alternative/technology using a consistent set of metrics. The assessment is conducted using a building block approach, where each remedial alternative is first broken down into modules that follow the phases for most remedial actions, including remedial investigation (RI), remedial action construction (RA-C), remedial action operation (RA-O), and long-term monitoring (LTM). Once broken down by remedial phase, the footprint of each phase is calculated. The phase-specific footprints are then combined to estimate the overall footprint of the remedial alternative. This building block approach reduces redundancy in the footprint assessment and facilitates the identification of specific impact drivers that contribute to the environmental footprint. The inputs that need to be considered include (1) production of material required by the activity; (2) transportation of the required materials to the site, transportation of personnel; (3) all site activities to be performed; and (4) management of the waste produced by the activity.

GSRx builds off of SiteWise™ and allows for a flexible, detailed analysis, particularly for materials and equipment use. GSRx was used to account for materials and activities not readily input into SiteWise™ and where equipment usage assumptions built into SiteWise™ were not consistent with site-specific requirements.

ENVIRONMENTAL FOOTPRINT EVALUATION FRAMEWORK AND LIMITATIONS

The environmental footprint evaluation performed for the FS/Corrective Measures Study for Site 4 (Area of Concern 22) – Former Underground Storage Tanks considered life-cycle quantitative metrics for global warming potential (through greenhouse gas emissions), criteria air pollutant emissions (through NO_x, SO_x and PM₁₀ emissions), energy consumption, water usage, and worker safety.

Life cycle impacts were calculated for energy consumption, emissions of GHG (carbon dioxide [CO₂], methane [CH₄], and nitrous oxide [N₂O]) and criteria pollutants (nitrogen oxides [NO_x], sulfur oxides [SO_x] and particulate matter [PM₁₀]), water usage, and energy consumption, and worker safety.

Life cycle inventory inputs in SiteWise™ were divided into four categories – 1) materials production; 2) transportation of personnel, materials and equipment; 3) equipment use and miscellaneous; and 4) residual handling and disposal. Cost estimates from the RI/FS and design calculations were used as a basis for inventory quantities and related assumptions. Emission factors, energy consumption, and water usage data were correlated to material quantities, equipment, transportation distances, and installation time frames in order to calculate life-cycle emissions, energy consumption, water usage, and worker safety. Default SiteWise™ emission, energy usage, water consumption, and worker fatality and accident risk factors were utilized.

Although GSRx was used to minimize limitations resulting within SiteWise™, elimination of all limitations was not possible while using a hybrid model of SiteWise™ and GSRx. For example, several materials and construction equipment inventoried were input into GSRx and these impacts were incorporated into SiteWise™ within the “Equipment Use and Miscellaneous” sector. This sector in SiteWise™ does not differentiate into the specific equipment usage or material consumption items that are input in GSRx, but rather are considered miscellaneous items. However, impact drivers for items input in GSRx can be identified and evaluated directly within the respective GSRx evaluation and output summary sheets. In addition, worker safety results in general do not include worker safety related to equipment usage that was input within GSRx because GSRx was not developed to evaluate worker safety.

EVALUATION RESULTS

The following are the alternatives that were analyzed with SiteWise™ and GSRx for the FS/Corrective Measures Study:

- Alternative 2: Monitored Natural Attenuation and Land Use Controls
- Alternative 3: Steam Injection and Free Product Recovery
- Alternative 4: Biosparging with Steam Injection and Free Product Recovery
- Alternative 5: Solvent Extraction and Free Product Recovery with Biosparging
- Alternative 6A: Excavation and Disposal of Soils (Soil TPH greater than 1,000 mg/Kg)
- Alternative 6B: Excavation and Disposal of Soils (Soil TPH greater than 10,000 mg/Kg)

The following sections summarize the relative environmental impacts and primary impact drivers for the six alternatives and their respective metrics. In addition, the attachment includes the inventory and output sheets that were used for the SiteWise™/GSRx hybrid model. An evaluation of SiteWise™ and GSRx output summary sheets and related figures included in the footprint evaluation attachments (Appendix E-2 and E-3), provides detailed information on the contribution to each metric from each phase of the remedial process (RI, RAC, RAO, and LTM) and for each respective input category (materials production, transportation, equipment usage, etc). Further inspection of related inventory sheets provide information on the specific contribution to a metric from each item of material, transportation, equipment, etc. This level of detail also helps clarify results that could be misinterpreted based on SiteWise™ data entry limitations mentioned previously. The environmental impacts of the alternatives analyzed are summarized quantitatively in Table E1.

Greenhouse Gas Emissions

Emissions of CO₂, CH₄, and N₂O were normalized to CO₂ equivalents (CO₂e), which is a cumulative method of weighing GHG emissions relative to global warming potential. Figure E1 shows the overall GHG emissions of each of the alternatives analyzed; the x-axis represents the six alternatives evaluated and the y-axis represents the GHG emissions in metric ton of CO₂e. Figure E2 shows the breakdown of the percent that each of the main activities of each alternative (x-axis) contributes to the GHG emissions (y-axis).

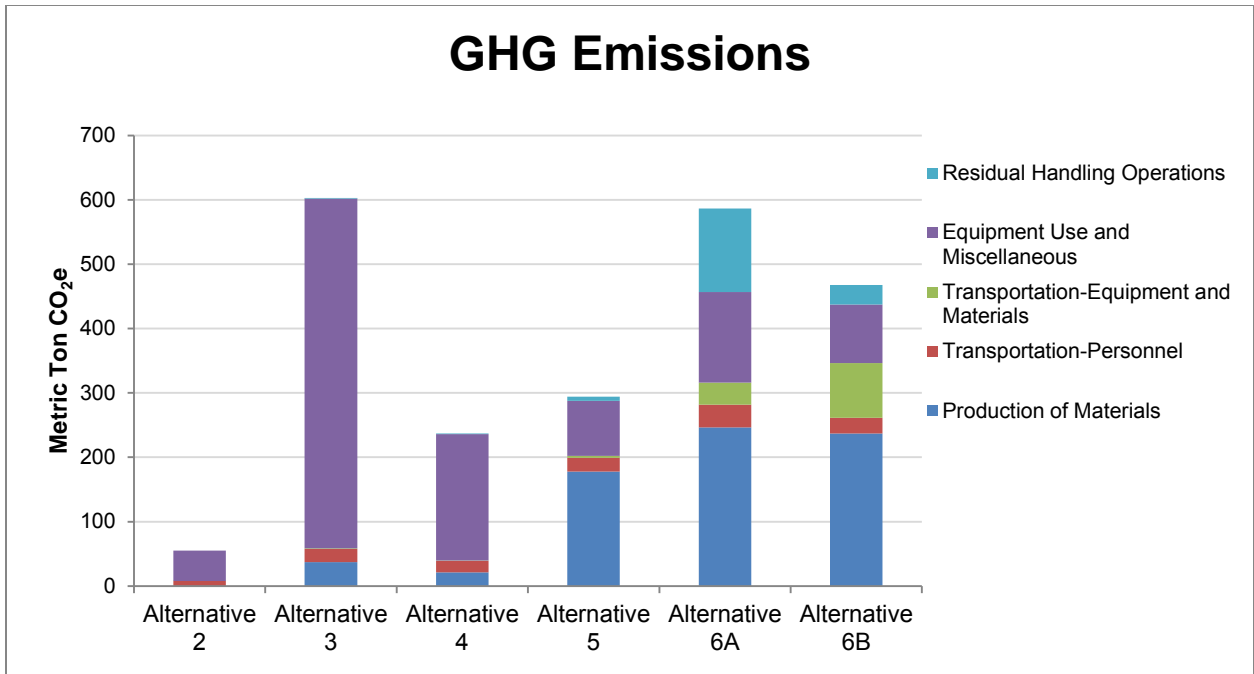

Figure E1: GHG Emissions for Alternatives at the Naval Weapons Industrial Reserve Plant in Bethpage, NY

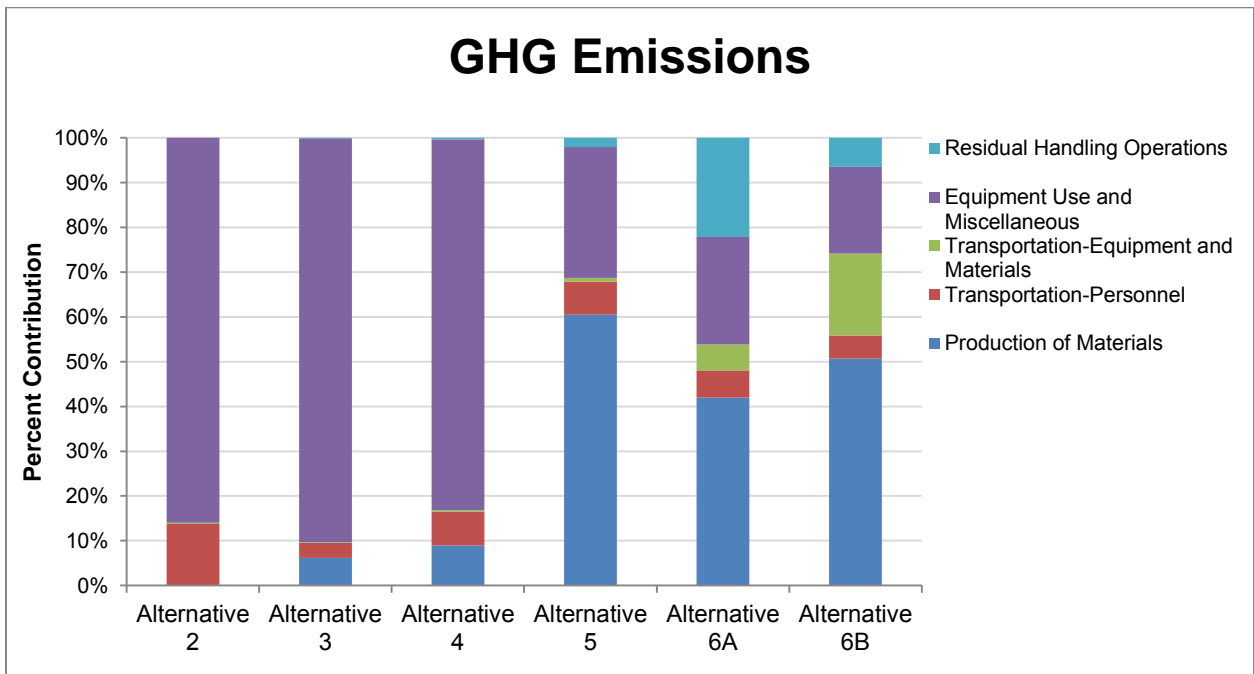

Figure E2: GHG Emissions percentage breakdown for Alternatives at the Naval Weapons Industrial Reserve Plant in Bethpage, NY

The total amount of GHG emissions from Alternative 2 is 55.9 metric ton of CO₂e. The main contributor the GHG emissions is laboratory and analytical services and the amount of emissions resulting from this activity is 46.0 metric ton of CO₂e, corresponding to 84 percent of the total GHG emissions. Transportation of personnel is the activity with the second highest contribution to GHG emissions with 7.5 metric ton of CO₂e released to the atmosphere through the lifetime of the project, corresponding to approximately 14 percent of the total GHG emissions. Use of DPT equipment is the activity with the third highest contribution to the CO₂e emissions, with 1.2 metric ton being released corresponding to approximately less than one percent of the total emissions.

The total amount of GHG emissions from Alternative 3 is 603 metric ton of CO₂e. The main contributor the GHG emissions is electricity use for steam injection and the amount of emissions resulting from this activity is 443.3 metric ton of CO₂e, corresponding to 73.5 percent of the total GHG emissions. Laboratory and analytical services is the activity with the second highest contribution to GHG emissions with 60.7 metric ton of CO₂e released to the atmosphere through the lifetime of the project, corresponding to approximately 10 percent of the total GHG emissions. Electricity use for product recovery is the activity with the third highest contribution to the CO₂e emissions, with 36.4 metric ton being released corresponding to 3.3 percent of the total emissions.

The total amount of GHG emissions from Alternative 4 is 236.9 metric ton of CO₂e. The main contributor the GHG emissions is electricity use for air injection and the amount of emissions resulting from this activity is 76.8 metric ton of CO₂e, corresponding to 32.4 percent of the total GHG emissions. Electricity use for steam injection is the activity with the second highest contribution to GHG emissions with 70.4 metric ton of CO₂e released to the atmosphere through the lifetime of the project, corresponding to 29.7 percent of the total GHG emissions. Laboratory and analytical services is the activity with the third highest contribution to the CO₂e emissions, with 36.0 metric ton being released corresponding to 15.2 percent of the total emissions.

The total amount of GHG emissions from Alternative 5 is 294.12 metric ton of CO₂e. The main contributor the GHG emissions is the production of Vertec (vegetable oil was used as a surrogate) for injection and the amount of emissions resulting from this activity is 154.28 metric ton of CO₂e, corresponding to 52 percent of the total GHG emissions. Electricity use for biosparging is the activity with the second highest contribution to GHG emissions with 64 metric ton of CO₂e released to the atmosphere through the lifetime of the project, corresponding to 22 percent of the total GHG emissions. Transportation of personnel is the activity with the third highest contribution to the CO₂e emissions, with 21.6 metric ton being released corresponding to approximately seven percent of the total emissions.

The total amount of GHG emissions from Alternative 6A is 587 metric ton of CO₂e. The main contributor the GHG emissions is the use of new soil as backfill and the amount of emissions resulting from this

activity is 220.9 metric ton of CO₂e, corresponding to 37.7 percent of the total GHG emissions. Residual Handling and Transport is the activity with the second highest contribution to GHG emissions with 129.9 metric ton of CO₂e released to the atmosphere through the lifetime of the project, corresponding to 22.2 percent of the total GHG emissions. Laboratory and analytical services is the activity with the third highest contribution to the CO₂e emissions, with 46.9 metric ton being released corresponding to 8.0 percent of the total emissions.

The total amount of GHG emissions from Alternative 6B is 468 metric ton of CO₂e. The main contributor the GHG emissions is the use of new soil as backfill and the amount of emissions resulting from this activity is 219.9 metric ton of CO₂e, corresponding to 47 percent of the total GHG emissions. Transportation of materials is the activity with the second highest contribution to GHG emissions with 84.4 metric ton of CO₂e released to the atmosphere through the lifetime of the project, corresponding to 18 percent of the total GHG emissions. Laboratory and analytical services is the activity with the third highest contribution to the CO₂e emissions, with 46.9 metric ton being released corresponding to 10 percent of the total emissions.

Criteria Pollutant Emissions

NO_x

Figure E3 shows the overall NO_x emissions of each of the alternatives analyzed; the x-axis represents the six alternatives evaluated and the y-axis represents the NO_x emissions in metric ton of NO_x. Figure E4 shows the breakdown of the percent that each of main activities of each alternative (x-axis) contributes to the NO_x emissions (y-axis).

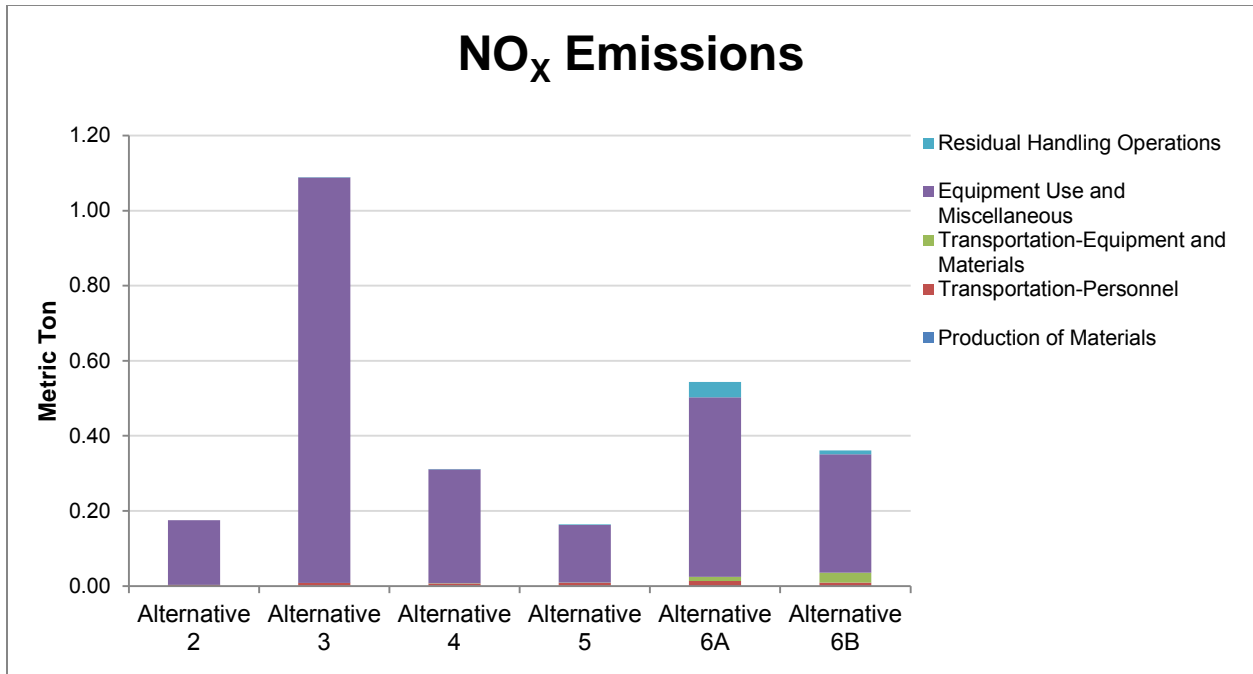

Figure E3 NO_x Emissions for Alternatives at the Naval Weapons Industrial Reserve Plant in Bethpage, NY

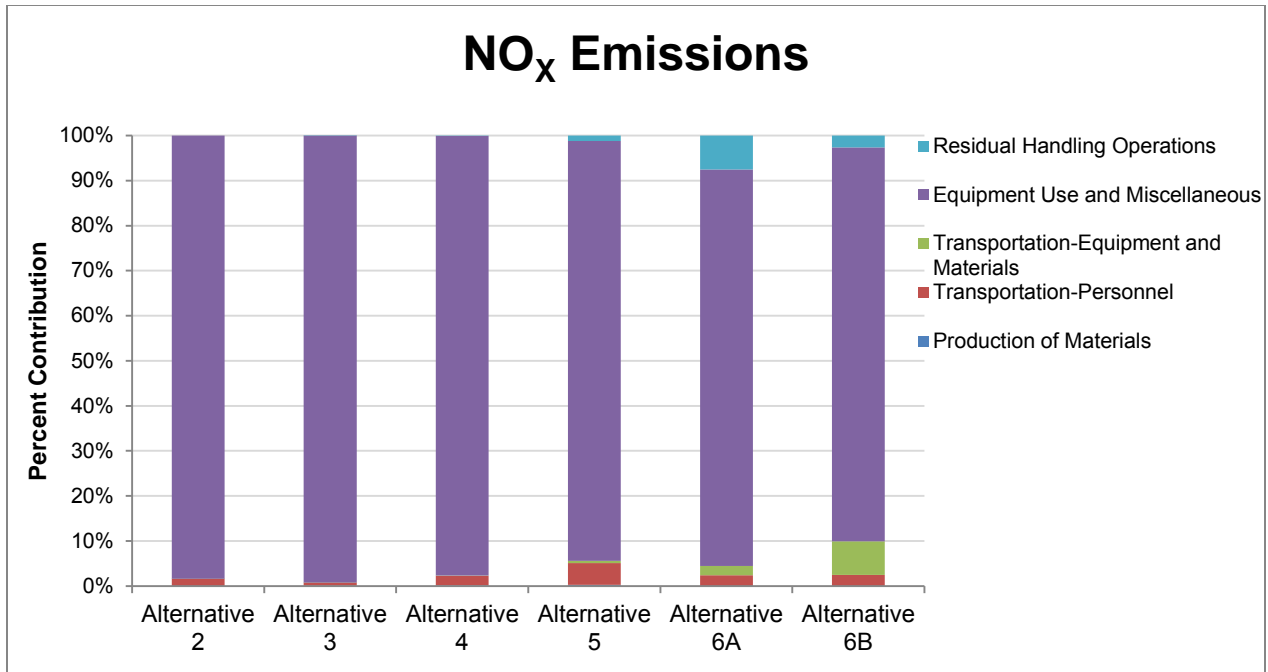

Figure E4: NO_x Emissions percentage breakdown for Alternatives at the Naval Weapons Industrial Reserve Plant in Bethpage, NY

The total amount of NO_x emissions from Alternative 2 is 1.75×10^{-1} metric ton. The activity with the highest contribution to NO_x emissions is the use of laboratory analytical services, emitting 1.6×10^{-1} metric ton of NO_x, corresponding to approximately 91 percent of the total NO_x emissions. Use of DPT equipment is the activity with the second highest contribution to NO_x emissions with 1.3×10^{-2} metric ton of NO_x released to the atmosphere through the lifetime of the project, corresponding to 7.4 percent of the total NO_x emissions. Transportation of personnel is the activity with the third highest contribution to the NO_x emissions, with 2.8×10^{-3} metric ton being released corresponding to 1.6 percent of the total emissions.

The total amount of NO_x emissions from Alternative 3 is 1.09 metric ton. The activity with the highest contribution to NO_x emissions is the use of electricity for steam injection, emitting 7.9×10^{-1} metric ton of NO_x, corresponding to approximately 72.5 percent of the total NO_x emissions. Laboratory analytical services is the activity with the second highest contribution to NO_x emissions with 2.1×10^{-1} metric ton of NO_x released to the atmosphere through the lifetime of the project, corresponding to 19.2 percent of the total NO_x emissions. Electricity used for product recovery is the activity with the third highest contribution to the NO_x emissions, with 6.5×10^{-2} metric ton being released corresponding to 5.9 percent of the total emissions.

The total amount of NO_x emissions from Alternative 4 is 3.1 x10⁻¹ metric ton. The activity with the highest contribution to NO_x emissions is laboratory analytical services, emitting 1.3x10⁻¹ metric ton of NO_x, corresponding to approximately 39.8 percent of the total NO_x emissions. Electricity used for air injection is the activity with the second highest contribution to NO_x emissions with 7.9x10⁻² metric ton of NO_x released to the atmosphere through the lifetime of the project, corresponding to 25.4 percent of the total NO_x emissions. Electricity used for steam injection is the activity with the third highest contribution to the NO_x emissions, with 7.3 x10⁻² metric ton being released corresponding to 23.2 percent of the total emissions.

The total amount of NO_x emissions from Alternative 5 is 1.64 x10⁻¹ metric ton. The activity with the highest contribution to NO_x emissions is electricity used for biosparging, emitting 6.61x10⁻² metric ton of NO_x, corresponding to approximately 40 percent of the total NO_x emissions. Laboratory analytical services is the activity with the second highest contribution to NO_x emissions with 6.57x10⁻² metric ton of NO_x released to the atmosphere through the lifetime of the project, corresponding to 40 percent of the total NO_x emissions. Use of DPT equipment is the activity with the third highest contribution to the NO_x emissions, with 1.2 x10⁻² metric ton being released corresponding to approximately seven percent of the total emissions.

The total amount of NO_x emissions from Alternative 6A is 5.43 x10⁻¹ metric ton. The activity with the highest contribution to NO_x emissions is excavator use, emitting 2.30x10⁻¹ metric ton of NO_x, corresponding to approximately 42.2 percent of the total NO_x emissions. Laboratory analytical services is the activity with the second highest contribution to NO_x emissions with 1.6x10⁻¹ metric ton of NO_x released to the atmosphere through the lifetime of the project, corresponding to 29.9 percent of the total NO_x emissions. Use of vibrator equipment for driving sheet piling is the activity with the third highest contribution to the NO_x emissions, with 7.5 x10⁻² metric ton being released corresponding to 13.9 percent of the total emissions.

The total amount of NO_x emissions from Alternative 6B is 3.61 x10⁻¹ metric ton. The activity with the highest contribution to NO_x emissions is laboratory analytical services, emitting 1.62x10⁻¹ metric ton of NO_x, corresponding to approximately 45 percent of the total NO_x emissions. Excavator use is the activity with the second highest contribution to NO_x emissions with 9.4x10⁻² metric ton of NO_x released to the atmosphere through the lifetime of the project, corresponding to 26.2 percent of the total NO_x emissions. Use of vibrator equipment for driving sheet piling is the activity with the third highest contribution to the NO_x emissions, with 5.0x10⁻² metric ton being released corresponding to 13.9 percent of the total emissions.

SO_x

Figure E5 shows the overall SO_x emissions of each of the alternatives analyzed; the x-axis represents the six alternatives evaluated and the y-axis represents the SO_x emissions in metric ton of SO_x. Figure E6 shows the breakdown of the percent that each of main activities of each alternative (x-axis) contributes to the SO_x emissions (y-axis).

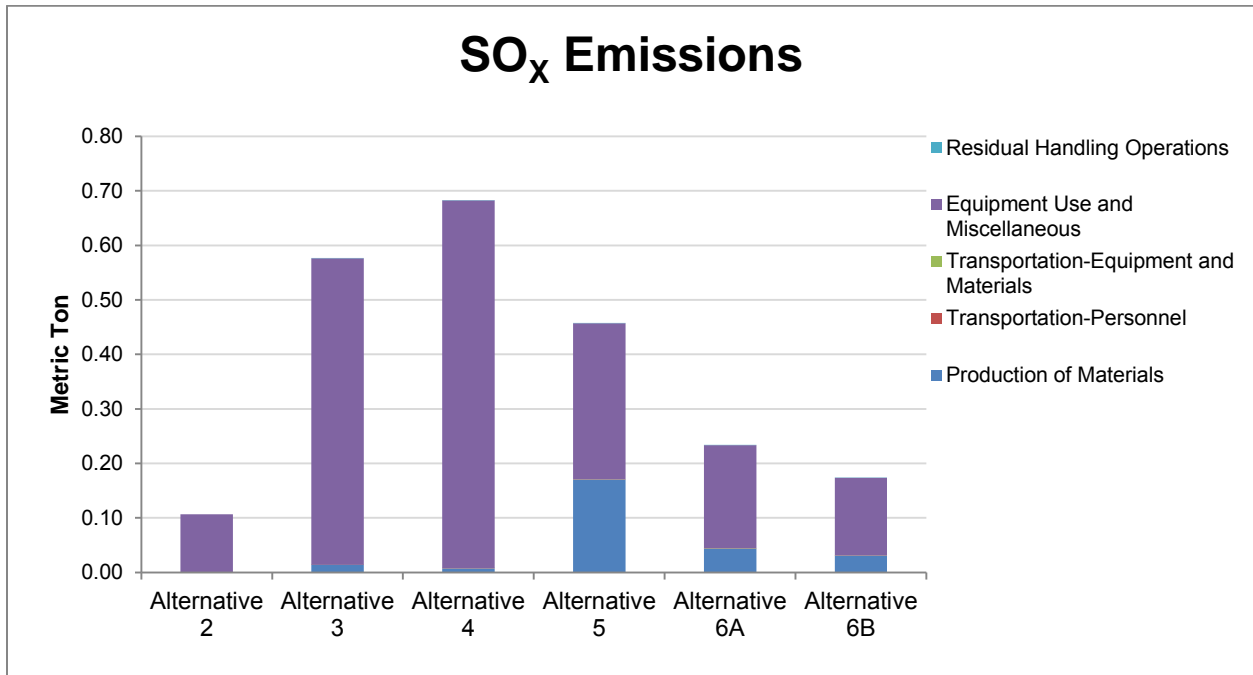

Figure E5: SO_x Emissions for Alternatives at the Naval Weapons Industrial Reserve Plant in Bethpage, NY

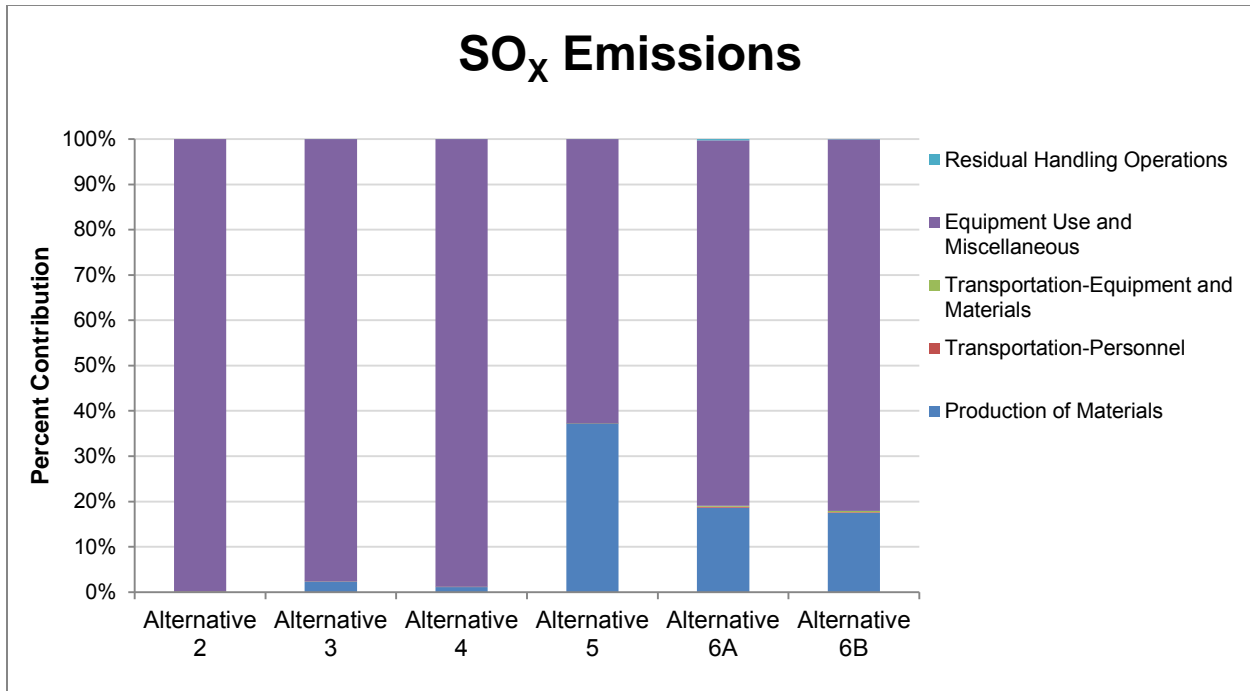

Figure E6: SO_x Emissions percentage breakdown for Alternatives at the Naval Weapons Industrial Reserve Plant in Bethpage, NY

The total amount of SO_x emissions from Alternative 2 is 1.06x10⁻¹ metric ton. The activity with the highest contribution to SO_x emissions is laboratory analytical services, emitting 1.06x10⁻¹ metric ton of SO_x, corresponding to approximately 99.7 percent of the total SO_x emissions. Use of DPT equipment is the activity with the second highest contribution and emits 2.6x10⁻² metric ton of SO_x, corresponding to approximately 0.24 percent of the total emissions. The activity with the third highest contribution to SO_x emissions is transportation of personnel, emitting 1.88x10⁻⁶ metric ton of SO_x corresponding to 0.09 percent of the total SO_x emissions.

The total amount of SO_x emissions from Alternative 3 is 0.58 metric ton. The activity with the highest contribution to SO_x emissions is electricity use for steam injection, emitting 3.86 x10⁻¹ metric ton of SO_x, corresponding to approximately 67 percent of the total SO_x emissions. Laboratory analytical services is the activity with the second highest contribution and emits 1.4x10⁻¹ metric ton of SO_x, corresponding to approximately 24.3 percent of the total emissions. The activity with the third highest contribution to SO_x emissions is electricity use for product recovery, emitting 3.17x10⁻² metric ton of SO_x corresponding to 5.5 percent of the total SO_x emissions.

The total amount of SO_x emissions from Alternative 4 is 0.68 metric ton. The activity with the highest contribution to SO_x emissions is electricity use for air injection, emitting 2.86 x10⁻¹ metric ton of SO_x, corresponding to approximately 41.9 percent of the total SO_x emissions. Electricity use for steam

injection is the activity with the second highest contribution and emits 2.62×10^{-1} metric ton of SO_x , corresponding to approximately 38.4 percent of the total emissions. The activity with the third highest contribution to SO_x emissions is laboratory analytical services, emitting 8.30×10^{-2} metric ton of SO_x corresponding to 12.16 percent of the total SO_x emissions.

The total amount of SO_x emissions from Alternative 5 is 4.57×10^{-1} metric ton. Electricity use for biosparging is the activity with the highest contribution to SO_x emissions, and emits 2.38×10^{-1} metric ton of SO_x , corresponding to 52 percent of the total emissions. The activity with the second highest contribution to SO_x emissions is the production of Vertec for injection, emitting 1.53×10^{-1} metric ton of SO_x , corresponding to approximately 34 percent of the total SO_x emissions. The activity with the third highest contribution to SO_x emissions is laboratory analytical services, emitting 4.38×10^{-2} metric ton of SO_x corresponding to approximately 10 percent of the total SO_x emissions.

The total amount of SO_x emissions from Alternative 6A is 0.23 metric ton. The activity with the highest contribution to SO_x emissions is laboratory analytical services, emitting 1.08×10^{-1} metric ton of SO_x , corresponding to approximately 46.7 percent of the total SO_x emissions. Excavator use is the activity with the second highest contribution and emits 6.77×10^{-2} metric ton of SO_x , corresponding to approximately 29.2 percent of the total emissions. The activity with the third highest contribution to SO_x emissions is the production of HDPE, emitting 4.30×10^{-2} metric ton of SO_x corresponding to 18.5 percent of the total SO_x emissions.

The total amount of SO_x emissions from Alternative 6B is 0.17 metric ton. The activity with the highest contribution to SO_x emissions is laboratory analytical services, emitting 1.08×10^{-1} metric ton of SO_x , corresponding to approximately 62.4 percent of the total SO_x emissions. Use and production of HDPE is the activity with the second highest contribution and emits 2.98×10^{-2} metric ton of SO_x , corresponding to approximately 17.1 percent of the total emissions. The activity with the third highest contribution to SO_x emissions is excavator use, emitting 2.79×10^{-2} metric ton of SO_x corresponding to 16 percent of the total SO_x emissions.

PM₁₀

Figure E7 shows the overall PM₁₀ emissions of each of the alternatives analyzed; the x-axis represents the six alternatives evaluated and the y-axis represents the PM₁₀ emissions in metric ton of PM₁₀. Figure E8 shows the breakdown of the percent that each of main activities of each alternative (x-axis) contributes to the PM₁₀ emissions (y-axis).

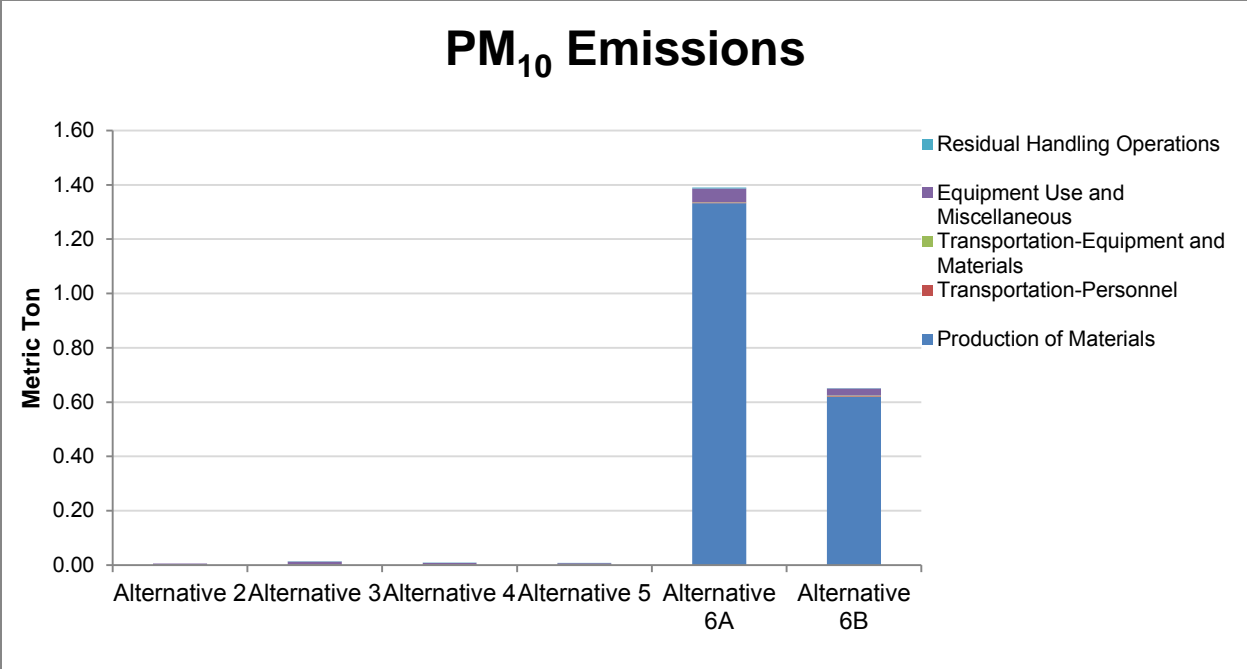

Figure E7: PM₁₀ Emissions for Alternatives at the Naval Weapons Industrial Reserve Plant in Bethpage, NY

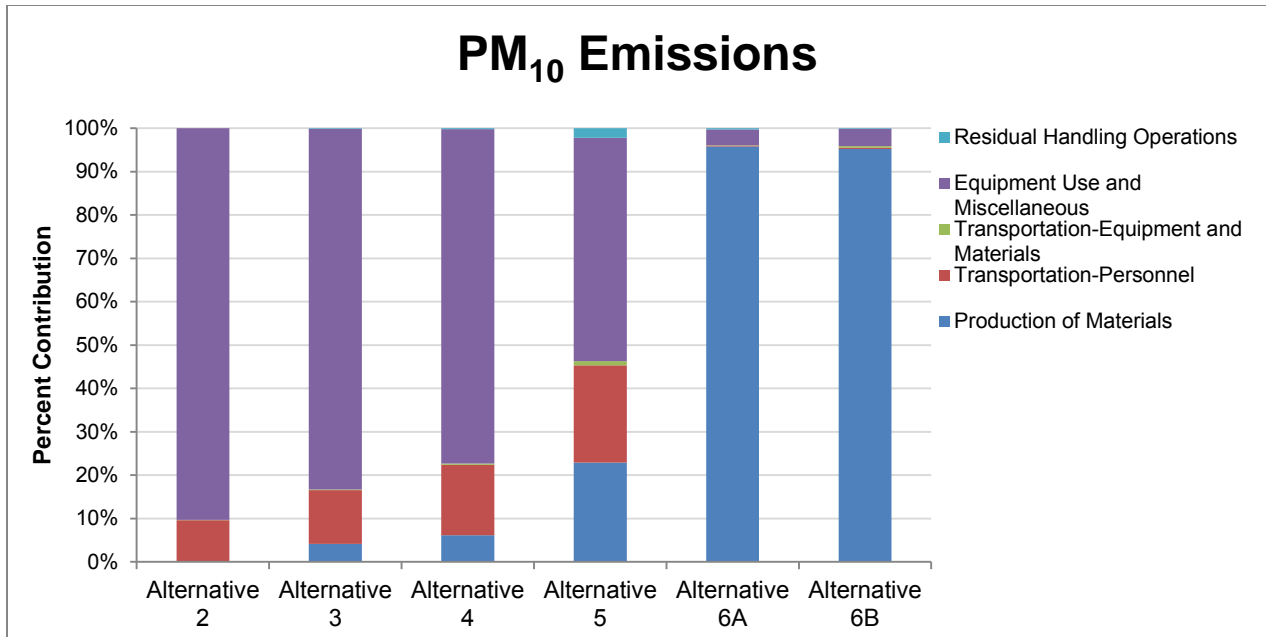

Figure E8: PM₁₀ Emissions percentage breakdown for Alternatives at the Naval Weapons Industrial Reserve Plant in Bethpage, NY

The total PM₁₀ emissions resulting from Alternative 2 is 5.98×10^{-3} metric ton. The activity with the highest contribution to these emissions is laboratory analytical services, emitting 4.03×10^{-3} metric ton of PM₁₀, approximately 68.5 percent of the total PM₁₀ emissions. DPT equipment use is the activity with the second highest contribution and emits 1.29×10^{-3} metric ton of PM₁₀, corresponding to approximately 22 percent of the total emissions. The activity with the third highest contribution to PM₁₀ emissions is transportation of personnel, emitting 5.66×10^{-4} metric ton of PM₁₀ corresponding to approximately 10 percent of the total PM₁₀ emissions.

The total PM₁₀ emissions resulting from Alternative 3 is 1.22×10^{-2} metric ton. The activity with the highest contribution to these emissions is laboratory analytical services, emitting 5.33×10^{-3} metric ton of PM₁₀, approximately 43.7 percent of the total PM₁₀ emissions. Municipal water used for steam injection is the activity with the second highest contribution and emits 3.48×10^{-3} metric ton of PM₁₀, corresponding to approximately 28.5 percent of the total emissions. The activity with the third highest contribution to PM₁₀ emissions is transportation of personnel, emitting 1.51×10^{-3} metric ton of PM₁₀ corresponding to 12.4 percent of the total PM₁₀ emissions.

The total PM₁₀ emissions resulting from Alternative 4 is 8.22×10^{-3} metric ton. The activity with the highest contribution to these emissions is laboratory analytical services, emitting 3.15×10^{-3} metric ton of PM₁₀, approximately 38.4 percent of the total PM₁₀ emissions. Municipal water used for steam injection is the

activity with the second highest contribution and emits 1.74×10^{-3} metric ton of PM_{10} , corresponding to approximately 21.2 percent of the total emissions. The activity with the third highest contribution to PM_{10} emissions is transportation of personnel, emitting 1.33×10^{-3} metric ton of PM_{10} corresponding to 16.2 percent of the total PM_{10} emissions.

The total PM_{10} emissions resulting from Alternative 5 is 7.21×10^{-3} metric ton. The activity with the highest contribution to PM_{10} emissions is laboratory analytical services, emitting 1.67×10^{-3} metric ton of PM_{10} corresponding to 23 percent of the total PM_{10} emissions. The activity with the second highest contribution to these emissions is the transportation of personnel, emitting 1.62×10^{-3} metric ton of PM_{10} , approximately 22 percent of the total PM_{10} emissions. The use of the DPT drill rig is the activity with the third highest contribution and emits 1.22×10^{-3} metric ton of PM_{10} , corresponding to approximately 17 percent of the total emissions.

The total PM_{10} emissions resulting from Alternative 6A is 1.39 metric ton. The activity with the highest contribution to these emissions is the use of asphalt, emitting 1.33 metric ton of PM_{10} , approximately 95.27 percent of the total PM_{10} emissions. Excavator use is the activity with the second highest contribution and emits 2.18×10^{-2} metric ton of PM_{10} , corresponding to approximately 1.57 percent of the total emissions. The activity with the third highest contribution to PM_{10} emissions is crane use, emitting 1.86×10^{-2} metric ton of PM_{10} corresponding to 1.34 percent of the total PM_{10} emissions.

The total PM_{10} emissions resulting from Alternative 6B is 0.65 metric ton. The activity with the highest contribution to these emissions is the use of asphalt, emitting 0.62 metric ton of PM_{10} , approximately 94.6 percent of the total PM_{10} emissions. Excavator use is the activity with the second highest contribution and emits 8.98×10^{-3} metric ton of PM_{10} , corresponding to approximately 1.38 percent of the total emissions. The activity with the third highest contribution to PM_{10} emissions is crane use, emitting 8.57×10^{-3} metric ton of PM_{10} corresponding to 1.32 percent of the total PM_{10} emissions.

Energy Consumption

Figure E9 shows the energy consumption of each of the alternatives analyzed; the x-axis represents the six alternatives evaluated and the y-axis represents the amount of energy consumed in units of million British Thermal Units (MMBTU). Figure E10 shows the percentage breakdown contribution of energy consumption from the different activity groups

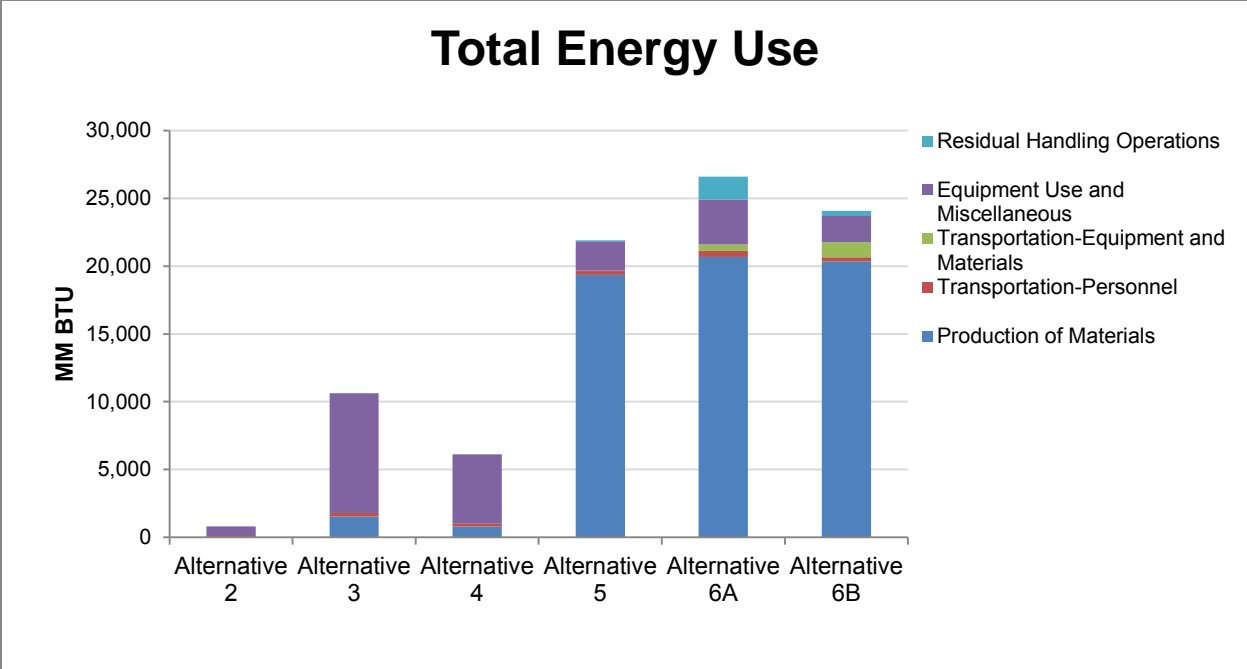

Figure E9: Energy Consumption for Alternatives at the Naval Weapons Industrial Reserve Plant in Bethpage, NY

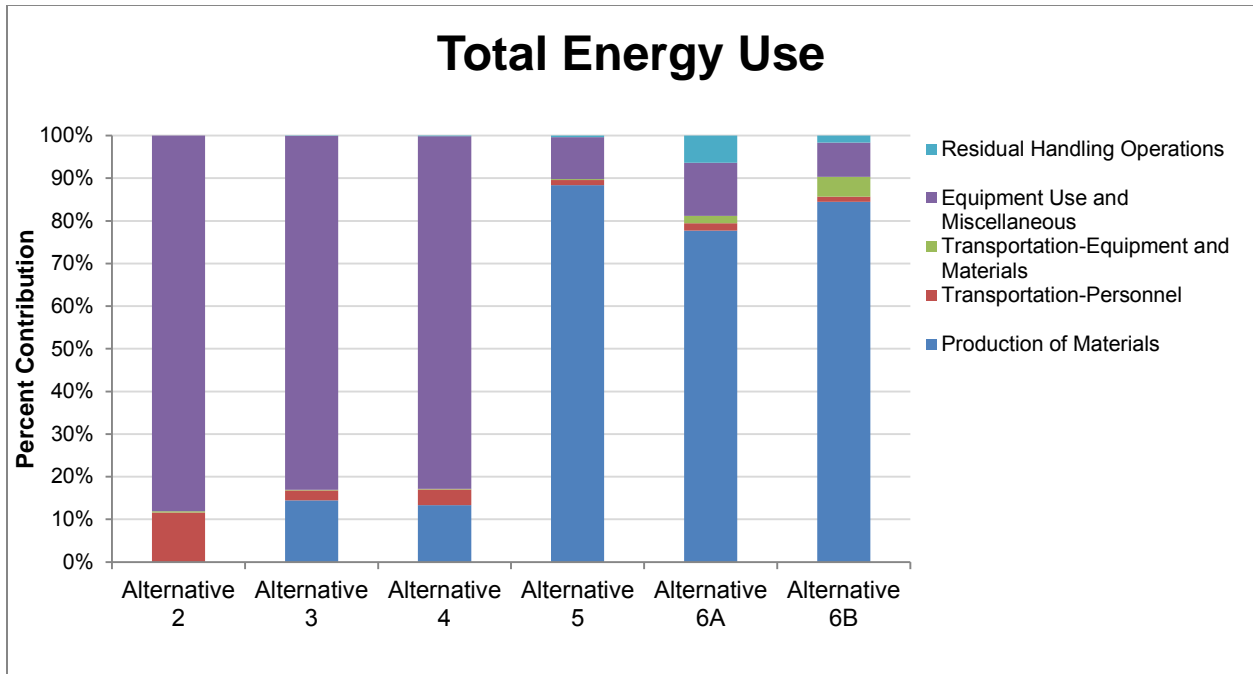

Figure E10: Energy Consumption percentage breakdown for Alternatives at the Naval Weapons Industrial Reserve Plant in Bethpage, NY

The total amount of energy consumed by Alternative 2 is 815.3 MMBTU. The activity with the highest energy consumption is laboratory analytical services, utilizing 686.4 MMBTU, corresponding to approximately 84.2 percent of the total energy consumption. The activity with the second highest energy use is the transportation of personnel, consuming 94.91 MMBTU, approximately 11.6 percent of the total energy consumption of this alternative. The third highest activity consuming energy corresponds to the use of DPT equipment, where 32 MMBTUs are consumed, approximately 0.24 percent of the total energy used during this alternative.

The total amount of energy consumed by Alternative 3 is 10,630 MMBTU. The activity with the highest energy consumption is electricity required for steam injection, utilizing 7,240 MMBTU, corresponding to approximately 68.2 percent of the total energy consumption. The activity with the second highest energy use is laboratory analytical services, consuming 906 MMBTU, approximately 8.52 percent of the total energy consumption of this alternative. The third highest activity consuming energy corresponds to the production of steel pipe, where 718 MMBTUs are consumed, approximately 6.75 percent of the total energy used during this alternative.

The total amount of energy consumed by Alternative 4 is 6,120 MMBTU. The activity with the highest energy consumption is electricity required for air injection, utilizing 2,170 MMBTU, corresponding to

approximately 35.5 percent of the total energy consumption. The activity with the second highest energy use is electricity required for steam injection, consuming 1,990 MMBTU, approximately 32.6 percent of the total energy consumption of this alternative. The third highest activity consuming energy corresponds to laboratory analytical services, where 537 MMBTUs are consumed, approximately 8.8 percent of the total energy used during this alternative.

The total amount of energy consumed by Alternative 5 is 21,916.50 MMBTU. The activity with the highest energy consumption is the production of Vertec for injection, utilizing 18,312 MMBTU, corresponding to 85 percent of the total energy consumption. The activity with the second highest energy use is electricity required for biosparging, consuming 1,810 MMBTU, approximately eight percent of the total energy consumption of this alternative. The third highest activity consuming energy corresponds to the production of steel pipe, where 410 MMBTUs are consumed, approximately two percent of the total energy used during this alternative.

The total amount of energy consumed by Alternative 6A is 26,600 MMBTU. The activity with the highest energy consumption is the use of new soil as backfill, utilizing 19,900 MMBTU, corresponding to approximately 74.9 percent of the total energy consumption. The activity with the second highest energy use is crane use, consuming 1,790 MMBTU, approximately 6.7 percent of the total energy consumption of this alternative. The third highest activity consuming energy corresponds to residual handling and transportation, where 1,696 MMBTUs are consumed, approximately 6.4 percent of the total energy used during this alternative.

The total amount of energy consumed by Alternative 6B is 24,090 MMBTU. The activity with the highest energy consumption is the use of new soil as backfill, utilizing 19,900 MMBTU, corresponding to approximately 82.3 percent of the total energy consumption. The activity with the second highest energy use is transportation of material, consuming 1,100 MMBTU, approximately 4.6 percent of the total energy consumption of this alternative. The third highest activity consuming energy corresponds to crane use, where 830 MMBTUs are consumed, approximately 3.4 percent of the total energy used during this alternative.

Water Usage

The water consumption of the evaluated alternatives is shown in Figure E11. The x-axis shows the six evaluated alternatives, and the y-axis show the amount of water consumed in thousands of gallons. Figure E12 shows the percentage breakdown contribution of the different sectors of the water use through the lifetime of the alternatives.

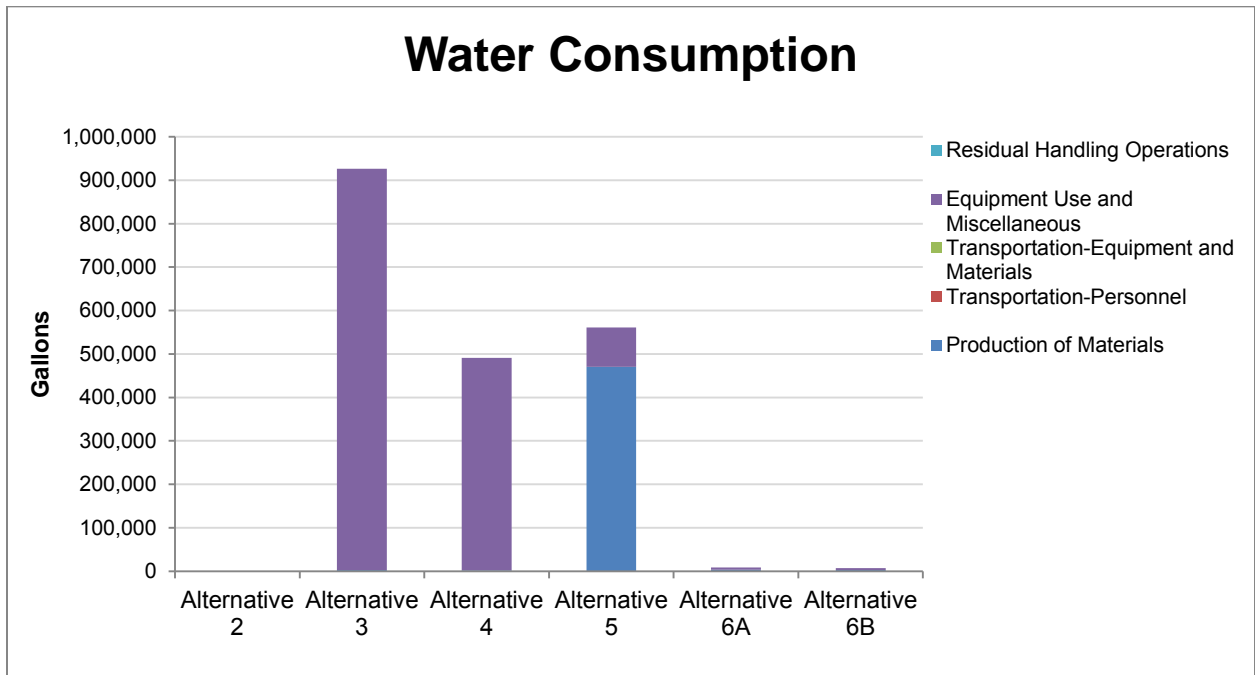

Figure E11: Water Consumption for Alternatives at the Naval Weapons Industrial Reserve Plant in Bethpage, NY

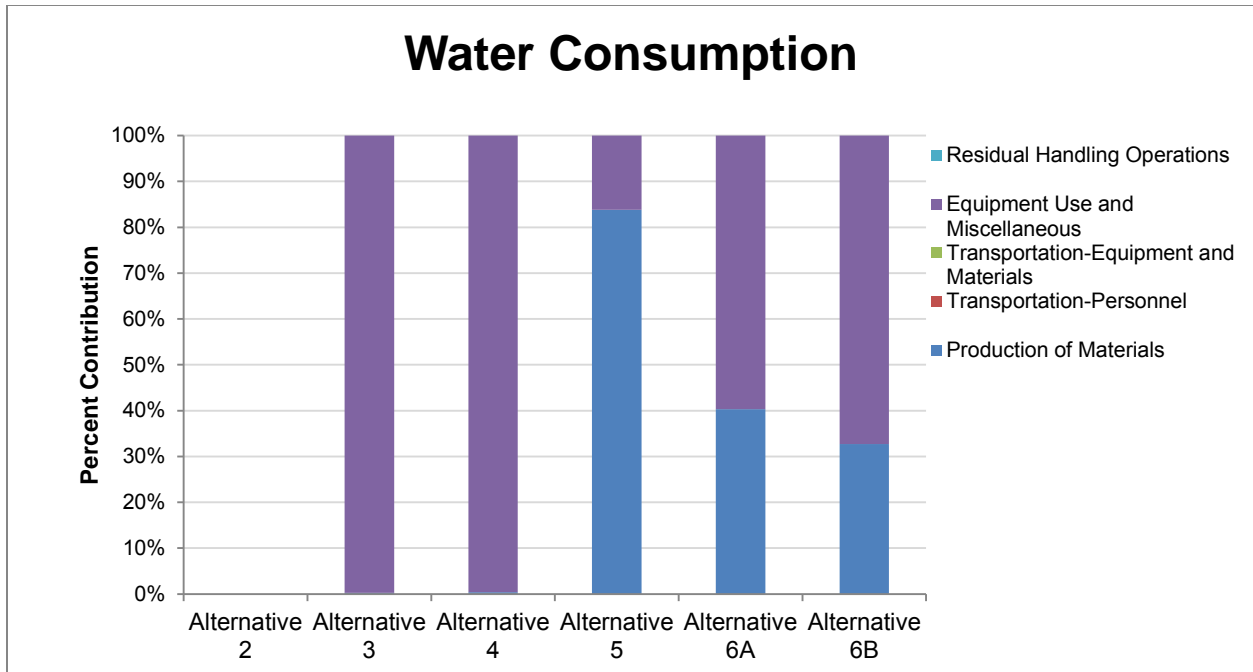

Figure E12: Water Consumption percentage breakdown for Alternatives at the Naval Weapons Industrial Reserve Plant in Bethpage, NY

Alternative 2 consists of long term monitoring and no water is considered consumed in this alternative.

The total water consumption for Alternative 3 is 926,600 gallons of water. The activity with the highest water usage is municipal water usage for steam injection, utilizing 536,000 gallons of water, corresponding to approximately 57.9 percent of water consumed. The activity with the second highest water usage is electricity generation for steam injection, consuming 357,400 gallons of water, approximately 38.6 percent of water consumed. The third highest water usage activity is electricity generation for free product recovery, consuming 29,400 gallons of water, approximately 3.2 percent of water consumed.

The total water consumption for Alternative 4 is 491,200 gallons of water. The activity with the highest water usage is municipal water usage for steam injection, utilizing 268,000 gallons of water, corresponding to approximately 54.6 percent of water consumed. The activity with the second highest water usage is electricity generation for air injection, consuming 107,200 gallons of water, approximately 21.8 percent of water consumed. The third highest water usage activity is electricity generation for steam injection, consuming 98,300 gallons of water, approximately 20 percent of water consumed.

The total water consumption for Alternative 5 is 561,105 gallons of water. The activity with the highest water usage is the production of Vertec, utilizing 465,640 gallons of water, corresponding to

approximately 83 percent of water consumed. The activity with the second highest water usage is electricity generation for biosparging, consuming 89,400 gallons of water, approximately 16 percent of water consumed. The third highest water usage activity corresponds to the production of PVC pipe, consuming 4,100 gallons of water, approximately less than one percent of water consumed.

The total water consumption for Alternative 6A is 8,400 gallons of water. The activity with the highest water usage is water required for decontamination of equipment, utilizing 5,000 gallons of water, corresponding to approximately 60 percent of water consumed. The activity with the second highest water usage corresponds to the production of HDPE, consuming 3,100 gallons of water, approximately 37 percent of water consumed. The third highest water usage activity corresponds to the production of PVC pipe, consuming 275 gallons of water, approximately three percent of water consumed.

The total water consumption for Alternative 6B is 7,400 gallons of water. The activity with the highest water usage is water required for decontamination of equipment, utilizing 5,000 gallons of water, corresponding to approximately 67 percent of water consumed. The activity with the second highest water usage corresponds to the production of HDPE, consuming 2,100 gallons of water, approximately 29 percent of water consumed. The third highest water usage activity corresponds to the production of PVC pipe, consuming 275 gallons of water, approximately four percent of water consumed.

Accident Risk

Accident Risk Fatality

Figure E13 shows the risk of fatality between the evaluated alternatives. The x-axis represents the six alternatives evaluated, and the y-axis represents the risk of fatality.

For all Alternatives, the activity with the highest risk of fatality is the transportation of personnel followed by the transportation of equipment and materials.

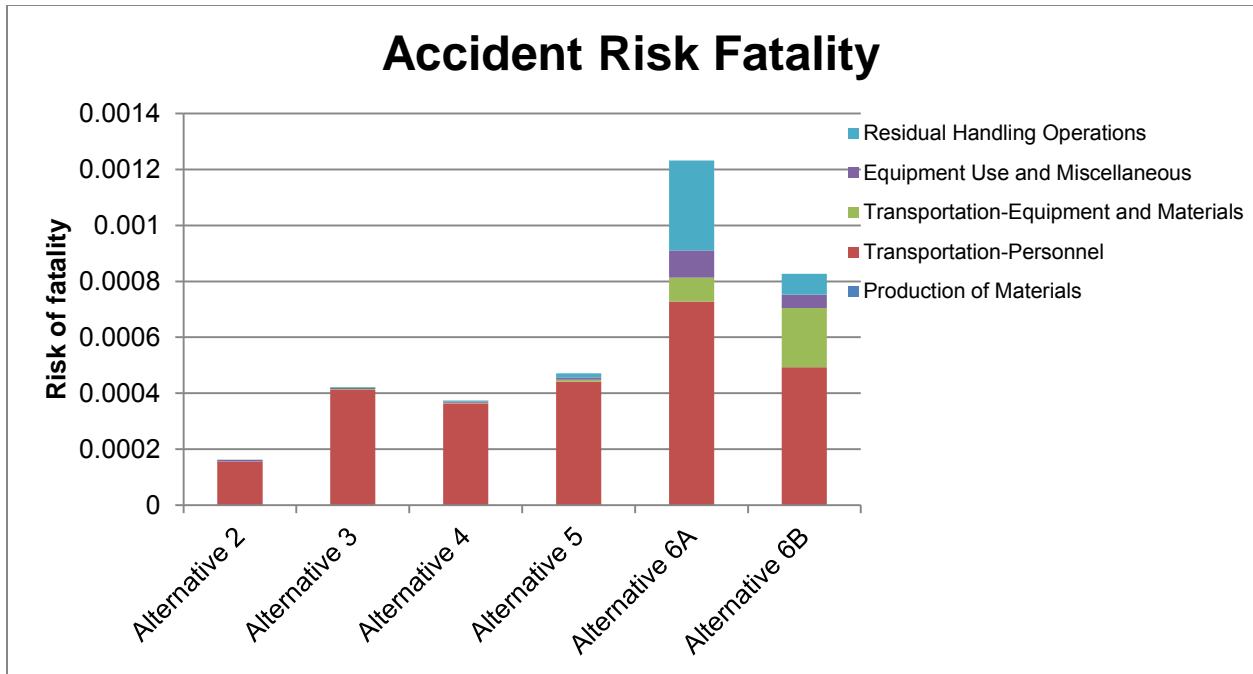

Figure E13 Risk of Fatality for Alternatives at the Naval Weapons Industrial Reserve Plant in Bethpage, NY

Accident Risk Injury

Figure E14 shows the risk of injury between the evaluated alternatives. The x-axis represents the six alternatives evaluated, and the y-axis represents the risk of injury.

For all Alternatives, the activity with the highest risk of injury is the transportation of personnel; the activity with the second highest risk of injury is the equipment use.

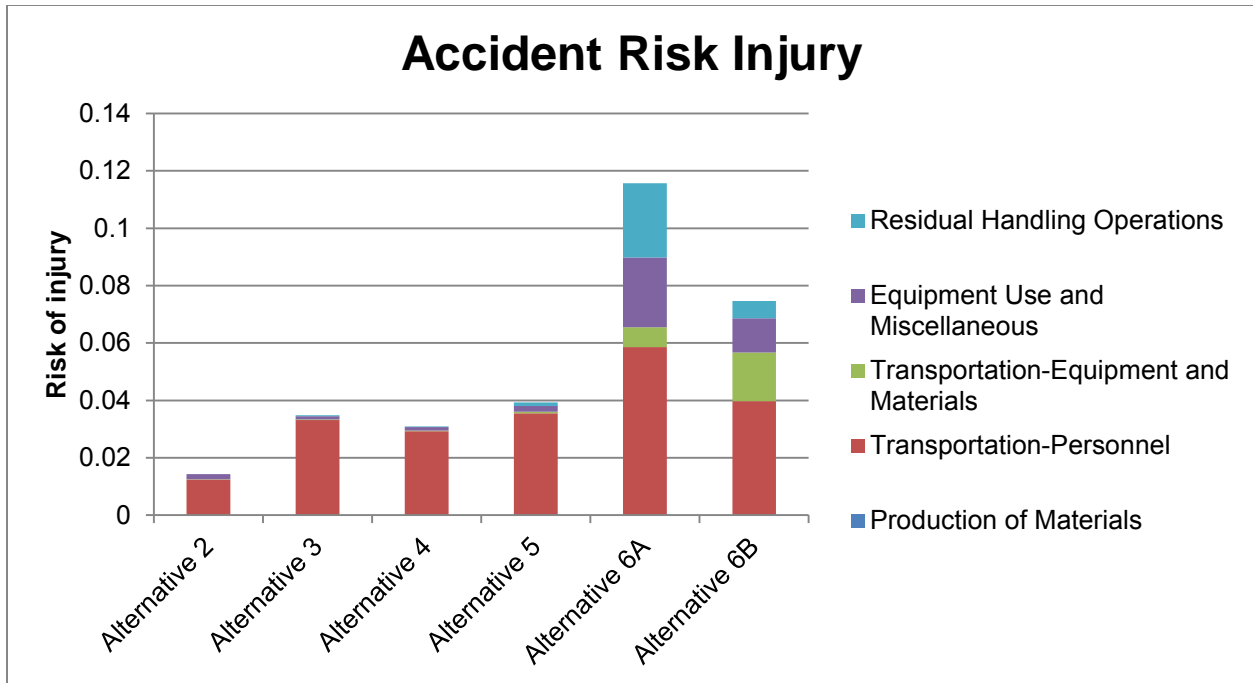

Figure E14 Risk of Injury for Alternatives at the Naval Weapons Industrial Reserve Plant in Bethpage, NY

CONCLUSIONS AND RECOMMENDATIONS

During selection and design of the remedy, a sensitivity analysis considering elements of the remedy that have the greatest impact on remedy effectiveness, life-cycle cost, and environmental footprint metrics may provide additional insight into appropriate optimization. To aid in the sensitivity analysis, an impact analysis summary was created to qualitatively highlight the relative impact of respective metrics for the two alternatives and to identify the primary drivers of emissions, energy consumption, and water usage for each alternative (see Table E2 for details).

Figures E2, E4, E6, E8, E10 and E12 show the percentage breakdown of each of the sectors that take place during the remedial alternatives. In these graphs, it is easy to identify the sector whose contribution is largest from all other sectors to that impact category. Identifying where the large contributions occur optimizes the process for potentially lowering the environmental impacts of each of the alternatives evaluated. Considering this, the following recommendations could noticeably reduce the environmental footprint of the alternatives listed below.

- Alternative 2: Consider further optimization and reducing the number of samples analyzed as the laboratory analytical services are the major driver in most of the impact categories.

- Alternative 3: Consider further optimization and reducing the use of steam injection during the treatment stage. The environmental impact of electricity production for steam injection has the most influence in most of the impact categories evaluated.
- Alternative 4: Consider further optimization and reducing the use of steam and air injection activities during the treatment stage. The environmental impact of electricity production for steam and air injection activities has the most influence in most of the impact categories evaluated.
- Alternative 5: Consider if the volume of Vertec used during the treatment stage could be reduced. Reducing the volume would significantly reduce the amount of GHG, NO_x, SO_x and PM₁₀ emissions released to the atmosphere as well as the amount of energy utilized.
- Alternatives 6A and 6B: Consider alternative means to acquire clean backfill. Acquiring clean fill that has been processed off-site is the major contributor in the impact categories of GHG and energy utilized for both of these alternatives.
- All Alternatives: Optimize the number of samples analyzed as the laboratory analytical services are one of the major drivers in some of the impact categories.
- All Alternatives: Consider ways to reduce vehicle mileage to reduce worker risk as well as energy use and emissions. Encourage site workers to carpool daily to the site to reduce total vehicle mileage.
- All Alternatives: Some reduction of the environmental footprint, particularly GHG emissions and energy consumption, could be realized for all alternatives through the possible use of emission control measures such as alternate fuel sources (e.g. biodiesel), equipment exhaust controls (e.g. diesel), and equipment idle reduction.

REFERENCES

- (a) NAVFAC, DON Guidance for Optimizing Remedy Evaluation, Selection, and Design, March 2010
- (b) NAVFAC, DON Policy on SiteWise™ Optimization/GSR Tool Usage, email received from Brian Harrison/NAVFAC HQ dated 10 AUG 2010

Table E-1
Environmental Footprint Evaluation Results
Site 4, Naval Weapons Industrial Reserve Plant
Bethpage, NY
Page 1 of 1

Alternative	Activities	GHG Emissions	Total Energy Used	Water Impacts	NO _x Emissions	SO _x Emissions	PM ₁₀ Emissions	Accident Risk Fatality	Accident Risk Injury
		Metric Ton CO ₂ e	MMBTU	Gallons	Metric Ton	Metric Ton	Metric Ton		
Alternative 2	Materials Production	0.00	0.00	0.00	0.00E+00	0.00E+00	0.00E+00	NA	NA
	Transportation-Personnel	7.55	94.91	NA	2.79E-03	9.83E-05	5.66E-04	1.54E-04	1.24E-02
	Transportation-Equipment	0.14	1.96	NA	4.61E-05	1.88E-06	3.74E-06	7.80E-07	6.28E-05
	Equipment Use and Misc	47.23	718.42	0.00	1.72E-01	1.06E-01	5.32E-03	7.05E-06	1.77E-03
	Residual Handling	0.00	0.00	NA	0.00E+00	0.00E+00	0.00E+00	0.00E+00	0.00E+00
	Total	54.91	815.30	0.00	1.75E-01	1.06E-01	5.89E-03	1.62E-04	1.43E-02
Alternative 3	Materials Production	37.33	1,534.56	2,344.67	7.53E-04	1.39E-02	5.08E-04	NA	NA
	Transportation-Personnel	20.12	253.10	NA	7.44E-03	2.62E-04	1.51E-03	4.12E-04	3.31E-02
	Transportation-Equipment	0.82	10.78	NA	2.59E-04	5.17E-06	2.28E-05	2.75E-06	2.21E-04
	Equipment Use and Misc	543.92	8,824.23	924,261.09	1.08E+00	5.62E-01	1.01E-02	4.60E-06	1.16E-03
	Residual Handling	0.79	10.44	NA	2.50E-04	6.19E-06	2.16E-05	3.12E-06	2.51E-04
	Total	602.99	10,633.12	926,605.77	1.09E+00	5.76E-01	1.22E-02	4.22E-04	3.48E-02
Alternative 4	Materials Production	21.22	815.94	1,783.02	3.74E-04	7.72E-03	5.08E-04	NA	NA
	Transportation-Personnel	17.76	223.38	NA	6.57E-03	2.31E-04	1.33E-03	3.63E-04	2.93E-02
	Transportation-Equipment	0.80	11.01	NA	2.59E-04	1.06E-05	2.10E-05	2.76E-06	2.22E-04
	Equipment Use and Misc	196.31	5,058.94	489,436.15	3.04E-01	6.75E-01	6.34E-03	4.69E-06	1.18E-03
	Residual Handling	0.79	10.72	NA	2.54E-04	8.72E-06	2.11E-05	3.51E-06	2.83E-04
	Total	236.89	6,119.99	491,219.17	3.11E-01	6.83E-01	8.22E-03	3.74E-04	3.09E-02
Alternative 5	Materials Production	177.92	19,368.34	470,224.54	3.78E-04	1.70E-01	1.65E-03	NA	NA
	Transportation-Personnel	21.57	271.32	NA	7.98E-03	2.81E-04	1.62E-03	4.41E-04	3.55E-02
	Transportation-Equipment	2.60	35.46	NA	8.37E-04	3.18E-05	6.85E-05	7.01E-06	5.64E-04
	Equipment Use and Misc	85.89	2,157.34	90,879.36	1.53E-01	2.87E-01	3.71E-03	7.98E-06	2.01E-03
	Residual Handling	6.13	84.04	NA	1.98E-03	8.05E-05	1.60E-04	1.60E-05	1.29E-03
	Total	294.12	21,916.50	561,103.90	1.64E-01	4.57E-01	7.21E-03	4.72E-04	3.94E-02
Alternative 6A	Materials Production	246.40	20,683.79	3,381.85	0.00E+00	4.37E-02	1.33E+00	NA	NA
	Transportation-Personnel	35.54	447.01	NA	1.31E-02	4.63E-04	2.67E-03	7.27E-04	5.85E-02
	Transportation-Equipment	33.97	464.73	NA	1.09E-02	4.38E-04	8.89E-04	8.62E-05	6.94E-03
	Equipment Use and Misc	140.88	3,310.35	5,000.00	4.78E-01	1.89E-01	5.09E-02	9.69E-05	2.44E-02
	Residual Handling	129.95	1,696.03	NA	4.08E-02	7.22E-04	3.63E-03	3.22E-04	2.59E-02
	Total	586.74	26,601.90	8,381.85	5.43E-01	2.34E-01	1.39E+00	1.23E-03	1.16E-01
Alternative 6B	Materials Production	237.07	20,343.38	2,432.88	0.00E+00	3.04E-02	1.33E+00	NA	NA
	Transportation-Personnel	24.10	303.20	NA	8.92E-03	3.14E-04	2.67E-03	4.93E-04	3.97E-02
	Transportation-Equipment	85.45	1,115.27	NA	2.69E-02	4.75E-04	8.89E-04	2.12E-04	1.70E-02
	Equipment Use and Misc	90.89	1,932.46	5,000.00	3.16E-01	1.43E-01	5.09E-02	4.75E-05	1.19E-02
	Residual Handling	30.24	394.71	NA	9.50E-03	1.68E-04	3.63E-03	7.49E-05	6.03E-03
	Total	467.76	24,089.02	7,432.88	3.61E-01	1.74E-01	1.39E+00	8.27E-04	7.47E-02

Table E-2
Environmental Impact Drivers
Site 4, Naval Weapons Industrial Reserve Plant
Bethpage, NY
Page 1 of 1

Alternatives	GHG Emissions	Energy Use	Water Consumption	NO _x Emissions	SO _x Emissions	PM ₁₀ Emissions	Risk of injury	Risk of fatality
Alternative 2	Low	Low	Low	Low	Low	Low	Low	Low
	Laboratory & Analytical Services	Laboratory & Analytical Services	Laboratory & Analytical Services	Laboratory & Analytical Services	Laboratory & Analytical Services	Laboratory & Analytical Services	Transportation-Personnel	Transportation-Personnel
Alternative 3	High	Low to moderate	High	High	High	Low	Low to moderate	Low to moderate
	Electricity for Steam Injection	Electricity for Steam Injection	Water Use for Steam Injection	Electricity for Steam Injection	Electricity for Steam Injection	Laboratory & Analytical Services	Transportation-Personnel	Transportation-Personnel
Alternative 4	Low to moderate	Low to moderate	Moderate	Low to moderate	High	Low	Low to moderate	Low to moderate
	Electricity for Air Injection	Electricity for Air Injection	Water Use for Steam Injection	Laboratory Services	Electricity for Air Injection	Laboratory & Analytical Services	Transportation-Personnel	Transportation-Personnel
Alternative 5	Moderate	High	Moderate to high	Low	Moderate to high	Low	Low to moderate	Low to moderate
	Solvent (Vertec)	Solvent (Vertec)	Solvent (Vertec)	Electricity used for Biosparge	Electricity used for Biosparge	Laboratory & Analytical Services	Transportation-Personnel	Transportation-Personnel
Alternative 6A	High	High	Low	Moderate	Low to moderate	High	High	High
	Backfill (soil)	Backfill (soil)	Decon Water Supply	Excavator Use	Laboratory & Analytical Services	Asphalt	Transportation-Personnel	Transportation-Personnel
Alternative 6B	Moderate to high	High	Low	Low to moderate	Low to moderate	Moderate	Moderate to high	Moderate to high
	Backfill (soil)	Backfill (soil)	Decon Water Supply	Laboratory & Analytical Services	Laboratory & Analytical Services	Asphalt	Transportation-Personnel	Transportation-Personnel

APPENDIX E-2 INPUT INVENTORIES AND ASSUMPTIONS

Input Inventory Alternative 2
 Site 4, Naval Weapons Industrial Reserve Plant
 Bethpage, New York
 Page 1 of 20

Alternative 2: Monitored Natural Attenuation and Land Use Controls

LTM			
Transportation-Personnel			
Item	Quantity	Units	Comments
Field Labor (GW sampling)	18,000.00	Miles	3 people, 4 day/year, 30 years
Field Labor (soil sampling)	1,350.00	Miles	3 people, 3 days/10 years, 30 years
Transportation-equipment			
Item	Quantity	Units	Comments
Drilling/Split Spoon to 70 ft (4 borings)	3.00	Ton	Assume 3 Tons
Equipment Use			
Item	Quantity	Units	Comments
Drilling/Split Spoon to 70 ft (4 borings)	15.36	hours	4 borings every 10 years, 3 events, 80% usage, 5 borings/day, 8 hours/day
Laboratory Analytical Services			
Item	Quantity	Units	Comments
Laboratory Analysis (VOCs, SVOCs, and Metals)	66,000.00	\$	11 GW samples/year, 30 years, \$200/sample
Laboratory Analysis (TPH and PAHs)	12,000.00	\$	20 soil samples/10 years, 3 events

Input Inventory Alternative 3
 Site 4, Naval Weapons Industrial Reserve Plant
 Bethpage, New York
 Page 2 of 20

Alternative 3: Steam Injection and Free Product Recovery

RI
RAC

Materials

Item	Quantity	Units	Comments
Temporary Equipment Decon Pad Liner	700.47	lb	assume HDPE, Assume 30ftx40ft, 3 mm thick, 0.95 g/cm3
Temporary Equipment Decon Pad Frame	514.68	lb	Assume wood, 4x4 in, (30ftx40ft pad) 140 ft of timber, density for pine 530 kg/m3
Decon Water	1,000.00	gallons	Typical use
Building & Footing (Concrete)	45,960.00	lb	assume block building with foundation, 600 ft2, Consider only concrete, weight of 0.5 ft of poured concrete 145 lb/ft2, 41 bags of cement Assume 12 ft high walls at 100 LF. 1350 blocks (40 lb/ea),
Building & Footing	54,000.00	lb	
Building & Footing	9,440.00	lb	4.72 tons of sand
1" Injection Wells (14 Clusters - 12 at 50 and 60, 4 at 70 feet)	2,654.40	lb	1 inch carbon steel pipe, 1580 LF, 1.68 lbs/ft
Steam Injection Piping (2 inch steel - underground)	1,022.00	lb	2 inch carbon steel pipe, 280 LF, 3.65 lbs/ft
6" Product Recovery Wells (5 at 60 feet)	5,691.00	lb	6 inch carbon steel pipe, 300 LF, 18.97 lbs/ft
Product Recovery Piping	602.25	lb	2 inch carbon steel pipe, 165 LF, 3.65 lbs/ft

Transportation-Personnel

Item	Quantity	Units	Comments
Field Labor (baseline sampling)	200.00	Miles	4 days, 50 miles/day, 1 person
Construction Oversight Start-Up (Supervisor, QC/H&S)	4,000.00	Miles	5 days/week, 2 months, 2 people, 50 miles/day
Construction Oversight (Supervisor, QC/H&S)	4,000.00	Miles	5 days/week, 2 months, 2 people, 50 miles/day
Construction Oversight (Supervisor, QC/H&S, Geologist)	6,000.00	Miles	5 days/week, 2 months, 3 people, 50 miles/day
Craft Labor (2 People)	4,000.00	Miles	5 days/week, 2 months, 2 people, 50 miles/day
Construction Oversight (Supervisor, QC/H&S, Geologist)	3,000.00	Miles	5 days/week, 1 months, 2 people, 50 miles/day
Craft Labor (2 People)	2,000.00	Miles	5 days/week, 1 months, 2 people, 50 miles/day

Transportation-equipment

Item	Quantity	Units	Comments
Construction Facilities (trailer, utilities) - 6 months	6.00	Ton	Assume 3 tons, 2 trips
Excavator (building construction), 2.5 CY	20.00	ton	1 excavator, 20 ton per excavator, 100 miles round trip
DPT Drill Rig	3.05	Ton	1 drill rig, 6100 lb, 100 miles round trip
Steam Generator/blowdown pump (50,000 BTU per Hour)	2.00	Ton	Assume 2 ton
Vacuum Recovery System (Tank and Blower)	1.00	Ton	Assume 1 ton
Pump to Oil Water Separator (2 gpm)	0.13	Ton	Assume 250 lbs

Input Inventory Alternative 3
 Site 4, Naval Weapons Industrial Reserve Plant
 Bethpage, New York
 Page 3 of 20

Water Treatment System	1.50 Ton	Assume 2 1000 lbs capacity GAC Vessels (500 lb/each) Assume 1000 lbs w/ carbon/vessel
Air Treatment	1.50 Ton	Assume 2 1000 lbs capacity GAC Vessels (500 lb/each) Assume 1000 lbs w/ carbon/vessel

Transportation-materials

Item	Quantity	Units	Comments
Temporary Equipment Decon Pad Liner	0.35	Ton	assume HDPE, Assume 30ftx40ft, 3 mm thick, 0.95 g/cm3
Temporary Equipment Decon Pad Frame	0.26	Ton	Assume wood, 4x4 in, (30ftx40ft pad) 140 ft of timber, density for pine 530 kg/m3
Building & Footing	76.45	ton	assume block building with foundation, 600 ft2, Consider only concrete and block materials, weight of 0.5 ft of poured concrete 145 lb/ft2, Assume 12 ft high walls at 100 LF. 1350 blocks, 41 bags of cement, 4.72 tons of sand
1" Injection Wells (14 Clusters - 12 at 50 and 60, 4 at 70 feet)	1.33	Ton	1 inch carbon steel pipe, 1580 LF, 1.68 lbs/ft
Steam Injection Piping (2 inch steel - underground)	0.51	Ton	2 inch carbon steel pipe, 280 LF, 3.65 lbs/ft
6" Product Recovery Wells (5 at 60 feet)	2.85	Ton	6 inch carbon steel pipe, 300 LF, 18.97 lbs/ft
Product Recovery Piping	0.30	Ton	2 inch carbon steel pipe, 165 LF, 3.65 lbs/ft

Equipment Use

Item	Quantity	Units	Comments
Excavator (building construction), 2.5 CY	14.21	Hours	excavate 600 ft2, 1 ft deep, 600 ft3/27cy= 22.2 cy, Assume 10 cy/day, 8 hrs/day, 80% utility
DPT Drill Rig (Air & Steam Injection wells)	25.60	Hours	20 wells, 5 wells/day, 8 hrs, 80% utility

Residual Handling

Item	Quantity	Units	Comments
Decon Water	4.17	Tons	1000 gallons, 8.34 lbs/gal

Transportation-residual handling

Item	Quantity	Units	Comments
Decon Water	100.00	miles	100 miles

Laboratory Analytical Services

Item	Quantity	Units	Comments
Laboratory Analysis (VOCs, SVOCs, and Metals)	2,200.00	\$	11 baseline samples, assume \$200/sample

RAO

Materials

Item	Quantity	Units	Comments
Water	536,112.00	gallons	Steam generator uses 17 gal/hr. 4 years operation, 90 % usage, Water usage is from municipal supply
GAC (Liquid & Vapor)	20,000.00	lbs	5000 lbs/year, 4 years operation, assume reactivated GAC

Input Inventory Alternative 3
 Site 4, Naval Weapons Industrial Reserve Plant
 Bethpage, New York
 Page 4 of 20

Transportation-Personnel

Item	Quantity	Units	Comments
Field Labor	6,400.00	Miles	4 days/year, 16 years, 2 people, 50 miles/day
Field Labor	1,600.00	Miles	4 days/year, 2 years, 2 people, 50 miles/day
Drilling/Split Spoon to 70 ft (4 borings)	1,600.00	Miles	4 days/year, 2 years, 2 people, 50 miles/day
Operator (1 day per week)	10,400.00	Miles	1 day/week, 4 years, 1 people, 50 miles/day
Operator (4 days per month)	9,600.00	Miles	2 day/week, 4 years, 1 people, 50 miles/day

Transportation-equipment

Item	Quantity	Units	Comments
Drilling/Split Spoon to 70 ft (4 borings)	3.05	Tons	1 drill rig, 6100 lb, 100 miles round trip, 4 years

Transportation-materials

Item	Quantity	Units	Comments
GAC (Liquid & Vapor)	10.00	tons	5000 lbs/year, 4 years operation, assume reactivated GAC, 50 mile trip

Equipment Use

Item	Quantity	Units	Comments
Drilling/Split Spoon to 70 ft (4 borings)	10.24	hours	4 soil samples. 5 samples per day. 2 events. 8 hour/day, 80 % utility
Steam Injection (20 KW)	700,800.00	Kw-hrs	Electricity Steam generator, 175,200 Kw-hrs/year
Product Recovery (30 KW)	57,600.00	Kw-hrs	Product Recovery, 14400 Kw-hrs/year
Pump to Oil Water Separator (2 gpm)	1,920.00	hours	2 gpm transfer pump, 5 days a month, 4 years, 8 hours/day, Assume 0.5 HP

Residual Handling

Item	Quantity	Units	Comments
Free Product Recovered	34.15	Tons	2275 gal/year, 0.9 SG, 4 years operation
GAC (Liquid & Vapor)	10.00	Tons	5000 lbs/year, 4 years operation

Transportation-residual handling

Item	Quantity	Units	Comments
Free Product Recovered	150.00	Miles	2275 gal/year, 0.9 SG, 4 years operation
GAC (Liquid & Vapor)	150.00	Miles	5000 lbs/year, 4 years operation

Laboratory Analytical Services

Item	Quantity	Units	Comments
Laboratory Analysis (VOCs, SVOCs, and Metals)	35,200.00	\$	11 samples, 16 years, assume \$200/sample
Laboratory Analysis (TPH and PAHs)	8,000.00	\$	20 samples, 2 years, assume \$200/sample Assume 4 liquid samples/month, Assume 2 vapor samples/month. Sampling for 4 years \$200 samples/month.
Water and Air monitoring	57,600.00	\$	

Input Inventory Alternative 4
 Site 4, Naval Weapons Industrial Reserve Plant
 Bethpage, New York
 Page 5 of 20

Alternative 4 - Biosparging with Steam Injection and Free Product Recovery

RI			
RAC			
Materials			
Item	Quantity	Units	Comments
Temporary Equipment Decon Pad Liner	700.47	lb	assume HDPE, Assume 30ftx40ft, 3 mm thick, 0.95 g/cm3
Temporary Equipment Decon Pad Frame	514.68	lb	Assume wood, 4x4 in, (30ftx40ft pad) 140 ft of timber, density for pine 530 kg/m3
Decon Water	1,000.00	gallons	Assumed use
Building & Footing (Concrete)	45,960.00	lb	assume block building with foundation, 600 ft2, Consider only concrete, wieght of 0.5 ft of poured concrete 145 lb/ft2, 41 bags of cement
Building & Footing	54,000.00	lb	Assume 12 ft high walls at 100 LF. 1350 blocks (40 lb/ea),
Building & Footing	9,440.00	lb	4.72 tons of sand
Air Injection Wells (1 inch diameter) 14 at 70 ft	1,646.40	lb	1 inch carbon steel pipe, 14 wells at 70 ft , 1.68 lbs/ft
Air Injection Wells (1 inch diameter) 100 ft	168.00	lb	1 inch carbon steel pipe, 100 ft , 1.68 lbs/ft
1" Injection Wells (14 Clusters - 12 at 50 and 60, 4 at 70 feet)	504.00	lb	1 inch carbon steel pipe, 300 LF, 1.68 lbs/ft
Steam Injection Piping (1 inch steel - underground)	302.40	lb	1 inch carbon steel pipe, 180 LF, 1.68 lbs/ft
6" Product Recovery Wells (1 at 60 feet)	1,138.20	lb	6 inch carbon steel pipe,60 LF, 18.97 lbs/ft
Product Recovery Piping	292.00	lb	2 inch carbon steel pipe,80 LF, 3.65 lbs/ft
Transportation-Personnel			
Item	Quantity	Units	Comments
Field Labor (baseline sampling)	200.00	Miles	4 days, 50 miles/day, 1 person
Construction Oversight Start-Up (Supervisor, QC/H&S)	6,000.00	Miles	5 days/week, 2 months, 3 people, 50 miles/day
Construction Oversight (Supervisor, QC/H&S)	4,000.00	Miles	5 days/week, 2 months, 2 people, 50 miles/day
Construction Oversight (Supervisor, QC/H&S, Geologist)	3,000.00	Miles	5 days/week, 1 months, 3 people, 50 miles/day
Craft Labor (2 People)	2,000.00	Miles	5 days/week, 1 months, 2 people, 50 miles/day
Construction Oversight (Supervisor, QC/H&S, Geologist)	3,000.00	Miles	5 days/week, 1 months, 3 people, 50 miles/day
Craft Labor (2 People)	2,000.00	Miles	5 days/week, 1 months, 2 people, 50 miles/day
Construction Oversight (Supervisor, QC/H&S, Geologist)	2,000.00	Miles	5 days/week, 1 months, 2 people, 50 miles/day
Craft Labor (2 People)	2,000.00	Miles	5 days/week, 1 months, 2 people, 50 miles/day
Transportation-equipment			
Item	Quantity	Units	Comments
Construction Facilities (trailer, utilities) - 6 months	6.00	Ton	Assume 3 tons, 2 trips

Input Inventory Alternative 4
 Site 4, Naval Weapons Industrial Reserve Plant
 Bethpage, New York
 Page 6 of 20

Excavator (building construction), 2.5 CY	20.00 ton	1 excavator, 20 ton per excavator, 100 miles round trip
Blower, 7 HP	0.20 ton	Assume 400 lb
DPT Drill Rig	3.05 Ton	1 drill rig, 6100 lb, 100 miles round trip
Steam Generator/blowdown pump (50,000 BTU per Hour)	2.00 Ton	Assume 2 ton
Vacuum Recovery System (Tank and Blower)	1.00 Ton	Assume 1 ton
Pump to Oil Water Separator (2 gpm)	0.13 Ton	Assume 250 lbs
Water Treatment System	1.50 Ton	Assume 2 1000 lbs capacity GAC Vessels (500 lb/each) Assume 1000 lbs w/ carbon/vessel
Air Treatment	1.50 Ton	Assume 2 1000 lbs capacity GAC Vessels (500 lb/each) Assume 1000 lbs w/ carbon/vessel

Transportation-materials

Item	Quantity	Units	Comments
Temporary Equipment Decon Pad Liner	0.35	Ton	assume HDPE, Assume 30ftx40ft, 3 mm thick, 0.95 g/cm3
Temporary Equipment Decon Pad Frame	0.26	Ton	Assume wood, 4x4 in, (30ftx40ft pad) 140 ft of timber, density for pine 530 kg/m3
Building & Footing	76.45	Ton	assume block building with foundation, 600 ft2, Consider only concrete and block materials, weight of 0.5 ft of poured concrete 145 lb/ft2, Assume 12 ft high walls at 100 LF. 1350 blocks, 41 bags of cement, 4.72 tons of sand
Air Injection Wells (1 inch diameter) 14 at 70 ft	0.82	Ton	1 inch carbon steel pipe, 14 wells at 70 ft , 1.68 lbs/ft
Air Injection Wells (1 inch diameter) 100 ft	0.08	Ton	1 inch carbon steel pipe, 100 ft , 1.68 lbs/ft
1" Injection Wells (14 Clusters - 12 at 50 and 60, 4 at 70 feet)	1.33	Ton	1 inch carbon steel pipe, 1580 LF, 1.68 lbs/ft
Steam Injection Piping (2 inch steel - underground)	0.51	Ton	2 inch carbon steel pipe, 280 LF, 3.65 lbs/ft
6" Product Recovery Wells (5 at 60 feet)	2.85	Ton	6 inch carbon steel pipe, 300 LF, 18.97 lbs/ft
Product Recovery Piping	0.30	Ton	2 inch carbon steel pipe, 165 LF, 3.65 lbs/ft

Equipment Use

Item	Quantity	Units	Comments
Excavator (building construction), 2.5 CY	14.21	Hours	excavate 600 ft2, 1 ft deep, 600 ft3/27cy= 22.2 cy, Assume 10 cy/day, 8 hrs/day, 80% utility
DPT Drill Rig (Air, Steam, Recovery wells)	26.88	Hours	21 wells, 5 wells/day, 8 hrs, 80% utility

Residual Handling

Item	Quantity	Units	Comments
Decon Water	4.17	Tons	1000 gallons, 8.34 lbs/gal

Transportation-residual handling

Item	Quantity	Units	Comments
Decon Water	100.00	miles	150 miles

Input Inventory Alternative 4
 Site 4, Naval Weapons Industrial Reserve Plant
 Bethpage, New York
 Page 7 of 20

Laboratory Analytical Services

Item	Quantity	Units	Comments
Laboratory Analysis (VOCs, SVOCs, and Metals)	2,200.00	\$	11 baseline samples, assume \$200/sample

RAO

Materials

Item	Quantity	Units	Comments
Water	268,056.00	gallons	Steam generator uses 17 gal/hr. 2 years operation, 90 % usage, assume water supply is from municipality
GAC (Liquid & Vapor)	10,000.00	lbs	5000 lbs/year, 2 years operation, assume reactivated GAC

Transportation-Personnel

Item	Quantity	Units	Comments
Field Labor	4,000.00	Miles	4 days/year, 10 years, 2 people, 50 miles/day
Field Labor	1,600.00	Miles	4 days/year, 2 years, 2 people, 50 miles/day
Drilling/Split Spoon to 70 ft (4 borings)	1,600.00	Miles	4 days/year, 2 years, 2 people, 50 miles/day
Air Injection Operator (26 days per year)	5,200.00	Miles	26 day/year, 4 years, 1 people, 50 miles/day
Steam Injection Operator (1 day per week)	5,200.00	Miles	1 day/week, 2 years, 1 people, 50 miles/day
Free Product Operator (4 days per month)	4,800.00	Miles	4 day/month, 2 years, 1 people, 50 miles/day

Transportation-equipment

Item	Quantity	Units	Comments
Drilling/Split Spoon to 70 ft (4 borings)	3.05	Tons	1 drill rig, 6100 lb, 100 miles round trip, 2 years

Transportation-materials

Item	Quantity	Units	Comments
GAC (Liquid & Vapor)	5.00	tons	5000 lbs/year, 2 years operation, assume reactivated GAC

Equipment Use

Item	Quantity	Units	Comments
Drilling/Split Spoon to 70 ft (4 borings)	10.24	hours	4 soil samples. 5 samples per day. 2 events. 8 hour/day, 80 % utility
Air Injection (6 KW)	210,240.00	Kw-hrs	52560 Kw-hrs/year. 4 years
Steam Injection (11 KW)	192,720.00	Kw-hrs	96360 Kw-hrs/year. 2 years
Product Recovery (30 KW)	28,800.00	Kw-hrs	14400 Kw-hrs/year, 2 years
Pump to Oil Water Separator (2 gpm)	960.00	hours	2 gpm transfer pump, 5 days a month, 2 years, 8 hours/day, Assume 0.5 HP

Residual Handling

Item	Quantity	Units	Comments
Free Product Recovered	29.65	tons	3950 gal/year, 0.9 SG, 2 years operation
GAC (Liquid & Vapor)	5.00	tons	5000 lbs/year, 2 years operation

Input Inventory Alternative 4
 Site 4, Naval Weapons Industrial Reserve Plant
 Bethpage, New York
 Page 8 of 20

Transportation-residual handling

Item	Quantity	Units	Comments
Free Product Recovered	150.00	Miles	3950 gal/year, 0.9 SG, 2 years operation
GAC (Liquid & Vapor)	150.00	Miles	5000 lbs/year, 2 years operation

Laboratory Analytical Services

Item	Quantity	Units	Comments
Laboratory Analysis (VOCs, SVOCs, and Metals)	22,000.00	\$	11 samples, 10 years, assume \$200/sample
Laboratory Analysis (TPH and PAHs)	8,000.00	\$	20 samples, 2 years, assume \$200/sample Assume 4 liquid samples/month, Assume 2 vapor samples/month. Sampling for 2 years \$200
Water and Air monitoring	28,800.00	\$	samples/month.

Input Inventory Alternative 5
 Site 4, Naval Weapons Industrial Reserve Plant
 Bethpage, New York
 Page 9 of 20

Alternative 5: Solvent Extraction and Free Product Recovery with Biosparging

RAC			
Materials			
Item	Quantity	Units	Comments
Temporary Equipment Decon Pad Liner	700.47	lb	assume HDPE, Assume 30ftx40ft, 3 mm thick, 0.95 g/cm ³
Temporary Equipment Decon Pad Frame	514.68	lb	Assume wood, 4x4 in, (30ftx40ft pad) 140 ft of timber, density for pine 530 kg/m ³
Decon Water	1,000.00	gallons	Assumed Use
Building & Footing (Concrete)	12,860.00	lb	assume block building with foundation, 160ft ² , Consider only concrete, wieght of 0.5 ft of poured concrete 145 lb/ft ² , 21 bags of cement
Building & Footing	28,080.00	lb	Assume 12 ft high walls at 52 LF. 702 blocks (40 lb/ea),
Building & Footing	4,920.00	lb	2.46 tons of sand
Solvent Injection Wells (12 at 70 ft and 32 at 20 ft)	1,065.60	lb	Assume 2 inch schedule 40 PVC pipe, 1480 LF,0.72 lbs/ft
Solvent Injection Piping	504.00	lb	Assume 2 inch schedule 40 PVC pipe, 700 LF,0.72 lbs/ft
Solvent (Vertec)	178,400.00	lb	20,000 gallons of Vertec, SG of 1.03, Vertec EL is technical grade ethyl lactate, carbon neutral formula. Used Vegetable Oil as closest chemical in GSRx. Assume density of vegetable oil 8.92 ppg
6" Product Recovery Wells (5 at 60 feet)	5,691.00	lb	6 inch carbon steel pipe, 300 LF, 18.97 lbs/ft
Product Piping	129.60	lb	Assume 2 inch schedule 40 PVC pipe,180 LF,0.72 lbs/ft
Transportation-Personnel			
Item	Quantity	Units	Comments
Field Labor (baseline sampling)	200.00	Miles	4 days, 50 miles/day, 1 person
Construction Oversight Start-Up (Supervisor, QC/H&S)	4,000.00	Miles	5 days/week, 2 months, 2 people, 50 miles/day
Construction Oversight (Supervisor, QC/H&S)	4,000.00	Miles	5 days/week, 2 months, 2 people, 50 miles/day
Construction Oversight (Supervisor, QC/H&S, Geologist)	6,000.00	Miles	5 days/week, 2 months, 3 people, 50 miles/day
Craft Labor (2 People)	4,000.00	Miles	5 days/week, 2 months, 2 people, 50 miles/day
Construction Oversight (Supervisor, QC/H&S)	2,000.00	Miles	5 days/week, 1 months, 2 people, 50 miles/day
Craft Labor (2 People)	2,000.00	Miles	5 days/week, 1 months, 2 people, 50 miles/day
Construction Oversight (Supervisor, QC/H&S)	1,000.00	Miles	5 days/week, 0.5months, 2 people, 50 miles/day
Craft Labor (2 People)	1,000.00	Miles	5 days/week, 0.5 months, 2 people, 50 miles/day
Transportation-equipment			
Item	Quantity	Units	Comments
Construction Facilities (trailer, utilities) - 6 months	6.00	Ton	Assume 3 tons, 2 trips

Input Inventory Alternative 5
 Site 4, Naval Weapons Industrial Reserve Plant
 Bethpage, New York
 Page 10 of 20

Excavator (building construction), 2.5 CY	20.00 ton	1 excavator, 20 ton per excavator, 100 miles round trip
DPT Drill Rig	3.05 Ton	1 drill rig, 6100 lb, 100 miles round trip
Product Recovery Pumps	0.08 ton	5 submersible pumps. Assume 1/3 HP. 30 lbs/each
Raw/Waste Oil Tank (10,000 gallon)	10.40 ton	2 - 10,000 gallon steel tanks. 10,400 lbs/each
Blower, 6 HP	0.20 ton	Assume 400 lb

Transportation-materials

Item	Quantity	Units	Comments
Temporary Equipment Decon Pad Liner	0.35	Ton	assume HDPE, Assume 30ftx40ft, 3 mm thick, 0.95 g/cm3
Temporary Equipment Decon Pad Frame	0.26	Ton	Assume wood, 4x4 in, (30ftx40ft pad) 140 ft of timber, density for pine 530 kg/m3
Building & Footing	28.73	Ton	assume block building with foundation, 160 ft2, Consider only concrete and block materials, weight of 0.5 ft of poured concrete 145 lb/ft2, Assume 12 ft high walls at 52 LF. 702 blocks (40 lb/ea), 21 bags of cement, 2.46 tons of sand
Solvent Injection Wells (12 at 70 ft and 32 at 20 ft)	0.53	Ton	Assume 2 inch schedule 40 PVC pipe, 1480 LF, 0.72 lbs/ft
Solvent Injection Piping	0.25	Ton	Assume 2 inch schedule 40 PVC pipe, 700 LF, 0.72 lbs/ft
Solvent (Vertec)	85.90	Ton	20,000 gallons of Vertec, SG of 1.03, Vertec EL is technical grade ethyl lactate, carbon neutral formula. Used Vegetable Oil as closest chemical in GSRx. Assume density of vegetable oil 8.92 ppg
6" Product Recovery Wells (5 at 60 feet)	2.85	Ton	6 inch carbon steel pipe, 300 LF, 18.97 lbs/ft
Product Piping	0.06	Ton	Assume 2 inch schedule 40 PVC pipe, 180 LF, 0.72 lbs/ft
Raw/Waste Oil Tank (10,000 gallon)	10.40	Ton	2 - 10,000 gallon steel tanks. 10,400 lbs/each

Equipment Use

Item	Quantity	Units	Comments
Excavator (building construction), 2.5 CY	14.21	Hours	excavate 600 ft2, 1 ft deep, 600 ft3/27cy= 22.2 cy, Assume 10 cy/day, 8 hrs/day, 80% utility
DPT Drill Rig (solvent injection wells)	56.32	Hours	44 solvent injection wells, 5 wells/day, 8 hrs, 80% utility
DPT Drill Rig (solvent extraction wells)	6.40	Hours	5 solvent injection wells, 5 wells/day, 8 hrs, 80% utility

Residual Handling

Item	Quantity	Units	Comments
Decon Water	4.17	Tons	1000 gallons, 8.34 lbs/gal

Transportation-residual handling

Item	Quantity	Units	Comments
Decon Water	100.00	miles	100 miles

Input Inventory Alternative 5
 Site 4, Naval Weapons Industrial Reserve Plant
 Bethpage, New York
 Page 11 of 20

Laboratory Analytical Services

Item	Quantity	Units	Comments
Laboratory Analysis (VOCs, SVOCs, and Metals)	2,200.00	\$	11 baseline samples, assume \$200/sample

RAO

Materials

Item	Quantity	Units	Comments
Solvent (Vertec)	859,020.00	lb	50,000 gallons of Vertec/year, SG of 1.03, Vertec EL is technical grade ethyl lactate, carbon neutral formula. Used Vegetable Oil as closest chemical in GSRx. Assume density of vegetable oil 8.92 ppg, 5000 lbs/year, 2 years operation, assume reactivated
GAC (Liquid & Vapor)	10,000.00	lbs	GAC

Transportation-Personnel

Item	Quantity	Units	Comments
Field Labor (GW Sampling)	4,000.00	Miles	4 days/year, 10 years, 2 people, 50 miles/day
Field Labor (soil Sampling)	1,600.00	Miles	4 days/year, 2 years, 2 people, 50 miles/day
Drilling/Split Spoon to 70 ft (4 borings)	1,600.00	Miles	4 days/year, 2 years, 2 people, 50 miles/day
Free Product Operator (200 days/year)	20,000.00	Miles	200 day/year, 2 years, 1 people, 50 miles/day
Biosparge Operator (26 days per year)	5,200.00	Miles	26 day/year, 4 years, 1 people, 50 miles/day

Transportation-equipment

Item	Quantity	Units	Comments
Drilling/Split Spoon to 70 ft (4 borings)	3.05	Tons	1 drill rig, 6100 lb, 100 miles round trip, 2 years

Transportation-materials

Item	Quantity	Units	Comments
Solvent (Vertec)	429.51	tons	50,000 gallons of Vertec/year, SG of 1.03, Vertec EL is technical grade ethyl lactate, carbon neutral formula. Assume 500 miles to deliver to site.

Equipment Use

Item	Quantity	Units	Comments
Drilling/Split Spoon to 70 ft (4 borings)	10.24	hours	4 soil samples. 5 samples per day. 2 events. 8 hour/day, 80 % utility
Product Recovery Pumps	4,160.00	hours	hours to operate 5 submersible pumps. Assume 1/3 HP. Assume 8 hurs/week for two years
Biosparge (5 KW)	175,200.00	Kw-hrs	43800 Kw-hrs/year. 4 years

Residual Handling

Item	Quantity	Units	Comments
Solvent/Product Transportation and Disposal	490.60	tons	55,000 gallons of Solvent and Product. Assume density of (mixed) liquid to be 8.92 ppg

Input Inventory Alternative 5
 Site 4, Naval Weapons Industrial Reserve Plant
 Bethpage, New York
 Page 12 of 20

Transportation-residual handling			
Item	Quantity	Units	Comments
Solvent/Product Transportation and Disposal	150.00	Miles	55,000 gallons of Solvent and Product. Assume density of (mixed) liquid to be 8.92 ppg

Laboratory Analytical Services			
Item	Quantity	Units	Comments
Laboratory Analysis (VOCs, SVOCs, and Metals)	22,000.00	\$	11 samples, 10 years, assume \$200/sample
Laboratory Analysis (TPH and PAHs)	8,000.00	\$	20 samples, 2 years, assume \$200/sample

Input Inventory Alternative 6B
 Site 4, Naval Weapons Industrial Reserve Plant
 Bethpage, New York
 Page 13 of 20

Alternative 6A: Excavation and Disposal of Soils (Soil TPH greater than 1,000 mg/Kg)

RAC			
Materials			
Item	Quantity	Units	Comments
Temporary Equipment Decon Pad Liner	700.47	lb	assume HDPE, Assume 30ftx40ft, 3 mm thick, 0.95 g/cm3
Temporary Equipment Decon Pad Frame	514.68	lb	Assume wood, 4x4 in, (30ftx40ft pad) 140 ft of timber, density for pine 530 kg/m3
Decon Water	5,000.00	gallons	Increased volume of water needed due to due numerous equipment required for alternative
Construction Entrance	166,666.67	lb	Assume 100 yd2 is needed for extrance, Assume 1 ft thick of gravel, 2.5 tons/CY
Material staging area (10 ml poly/hay bales 160 ft X 120 ft)	7,920.00	lb	Used the following Material handling pad info to develop wieght. HDPE Liner, 5000 sf, 10 oz/sy, 16 oz/lb, 343.75 lbs
Backfill (off-site Source)	21,000,000.00	lbs	
Top Soil	180,000.00	lbs	60 yd3, Assume 1.5 ton/cy, 2000 lb/ton
Repaving (Stone)	365,400.00	lbs	560 yd2, Assume 6 inches thick, 145 lbs/ft3
Repaving (Asphalt)	182,700.00	lbs	560 yd2, Assume 3 inches thick, 145lbs/ft3
Revegetation seed	10.00	lb	
Monitoring Well Installation	115.20	lb	2 wells, Assume 80 ft depth, Assume 2 inch schedule 40 PVC pipe, 160 LF,0.72 lbs/ft

Transportation-Personnel			
Item	Quantity	Units	Comments
Field Labor (baseline sampling)	200.00	Miles	4 days, 50 miles/day, 1 person
Geologist	1,000.00	Miles	20 days, 50 miles/day
Construction Oversight (Supervisor, QC/H&S)	4,000.00	Miles	5 days/week, 2 months, 2 people, 50 miles/day
Operator and laborers (Assume 1 operators and 2 laboreres)	48,000.00	Miles	5 days/week, 16 months, 3 people, 50 miles/day
Construction Oversight (Supervisor, QC/H&S)	32,000.00	Miles	5 days/week, 16 months, 2 people, 50 miles/day
Well Installation (Geologist)	50.00	Miles	1 days, 50 miles/day, 1 person
Construction Oversight (Supervisor, QC/H&S)	4,000.00	Miles	5 days/week, 2 months, 2 people, 50 miles/day

Transportation-equipment			
Item	Quantity	Units	Comments
Drilling/Split Spoon	3.05	Ton	1 drill rig, 6100 lb, 100 miles round trip
Construction Facilities (trailer, utilities) - 18 months	6.00	Ton	Assume 3 tons, 2 trips
Site Prep (high vis fence, traffic control, E&S controls)	1.17	Ton	Assume 3 times the perimeter of excavation. Fence, 6 ft high chain link, 108 lb per 50 ft long, galvanized steel
Excavator 2.5 CY	20.00	ton	1 excavator, 20 ton per excavator, 100 miles round trip
Front End Loader	20.00	ton	1 Front End Loader, 20 ton , 100 miles round trip
Clamshell Crane (Excavation lifting)	40.00	ton	1 clamshell Crane, 20 ton , 100 miles round trip

Input Inventory Alternative 6B
 Site 4, Naval Weapons Industrial Reserve Plant
 Bethpage, New York
 Page 14 of 20

Crawler Crane (Sheet Piling) Vibrator Hammer & Generator (Sheet Piling)	40.00 ton 5.00 ton	1 crawler crane, 20 ton , 100 miles round trip 5 ton , 100 miles round trip
---	-----------------------	--

Transportation-materials

Item	Quantity	Units	Comments
Temporary Equipment Decon Pad Liner	0.35	Ton	assume HDPE, Assume 30ftx40ft, 3 mm thick, 0.95 g/cm3
Temporary Equipment Decon Pad Frame	0.26	Ton	Assume wood, 4x4 in, (30ftx40ft pad) 140 ft of timber, density for pine 530 kg/m3
Site Prep (high vis fence, traffic control, E&S controls) Construction Entrance	1.17 83.33	Ton Tons	Assume 3 times the perimeter of excavation. Fence, 100 yd2, Assume 1 ft thick of gravel, 2.5 tons/CY
Material staging area (10 ml poly/hay bales 160 ft X 120 ft)	3.30	Tons	Used the following Material handling pad info to develop wieght. HDPE Liner, 5000 sf, 10 oz/sy, 16 oz/lb, 343.75 lbs
Backfill (off-site Source)	10,500.00	Tons	
Fuel (500 gallons a week)	131.36	Tons	35,000 gallons of fuel, SG of 0.9, 8.34 lbs/gallon
Repaving (Stone)	182.70	Tons	560 yd2, Assume 6 inches thick, 145 lbs/ft3
Repaving (Asphalt)	91.35	Tons	560 yd2, Assume 3 inches thick, 145lbs/ft3
Revegetation seed	0.01	Tons	Assume 3 lb of seed per 1.2 msf
Monitoring Well Installation	0.06	Tons	2 wells, Assume 80 ft depth, Assume 2 inch schedule 40 PVC pipe, 160 LF,0.72 lbs/ft

Equipment Use

Item	Quantity	Units	Comments
Drilling/Split Spoon	38.40	Hours	30 borings, 5 borings /day, 8 hrs, 80% utility
Asphalt Removal (Excavator)	8.00	Hours	560 yd2, Assume 690 yd2/day,
Asphalt Removal (Loader)	8.00	Hours	560 yd2, Assume 690 yd2/day,
Sheet Piling (Crawler Crane)	138.66	Hours	Use FT2 of sheet piling needed. 360 ft perimiter. 71 ft bgs. 25 ft depth installation described in RS Means. Daily Output = 553 ft2/day. Multiply hours by 3 due complexity in driving to 71 bgs
Sheet Piling (Vibrator Hammer & Generator)	138.66	Hours	Consider time needed is same as above
Excavation (2.5 CY Excavator)	175.69	hours	21,000 CY, 765 CY/day, 80 utility
Excavation (Clamshell Crane)	175.69	hours	21,000 CY, 765 CY/day, 80 utility
Concrete UST Pad Removal and Disposal (2.5 CY Excavator)	1.15	hours	46 CY, 255 CY/day, 80 utility
Backfill of Soils for Reuse (14,000 Cu Yds) Excavator	117.12	hours	14,000 CY, 765 CY/day, 80 utility
Backfill of Soils for Reuse (14,000 Cu Yds) Clamshell Crane	117.12	hours	14,000 CY, 765 CY/day, 80 utility
Backfill (off-site Source) Excavator	58.56	hours	7,000 CY, 765 CY/day, 80 utility
Backfill (off-site Source) Clamshell Crane	58.56	hours	7,000 CY, 765 CY/day, 80 utility
Grading (top soil)	6.25	Hours	Use 150ft X 150ft for Grading. Daily output 400 YD2

Input Inventory Alternative 6B
 Site 4, Naval Weapons Industrial Reserve Plant
 Bethpage, New York
 Page 15 of 20

Asphalt Paving	0.73 Hours	560 yd2. Assume 3 inches. Daily output 4905 YD2
Material Staging Area Removal (Excavator)	8.00 Hours	Assume 1 day
General Construction Debris Removal (Excavator)	8.00 Hours	Assume 1 day

Residual Handling

Item	Quantity	Units	Comments
Decon Water	20.85	Tons	5000 gallons, 8.34 lbs/gal Assume 2 inch schedule 40 PVC pipe, 150 LF, 0.72 lbs/ft
Well Removal	0.05	Tons	
Asphalt Removal	91.35	Tons	560 yd2, Assume 3 inches thick, 145lbs/ft3
Load, Transport, and Dispose	10,500.00	Tons	
Concrete UST Pad Removal and Disposal (2.5 CY Excavator)	115.00	Tons	46 yd3, Assume 2.5 ton/cy, 2000 lb/ton
Repaving (Stone)	182.70	Tons	560 yd2, Assume 6 inches thick, 145 lbs/ft3
Repaving (Asphalt)	91.35	Tons	560 yd2, Assume 3 inches thick, 145lbs/ft3
Material Staging Area Removal	3.30	Tons	Used the following Material handling pad info to develop wieght. HDPE Liner, 5000 sf, 10 oz/sy, 16 oz/lb, 343.75 lbs
General Construction Debris Removal	1.00	Tons	Assume 2000 lbs of General Construction Debris

Transportation-residual handling

Item	Quantity	Units	Comments
Decon Water	150.00	miles	100 miles Assume 2 inch schedule 40 PVC pipe, 150 LF, 0.72 lbs/ft
Well Removal	150.00	miles	
Asphalt Removal	150.00	miles	560 yd2, Assume 3 inches thick, 145lbs/ft3
Load, Transport, and Dispose	150.00	miles	
Concrete UST Pad Removal and Disposal (2.5 CY Excavator)	150.00	miles	
Material Staging Area Removal	150.00	miles	Used the following Material handling pad info to develop wieght. HDPE Liner, 5000 sf, 10 oz/sy, 16 oz/lb, 343.75 lbs
General Construction Debris Removal	150.00	miles	Assume 2000 lbs of General Construction Debris

Laboratory Analytical Services

Item	Quantity	Units	Comments
Laboratory Analysis (VOCs, SVOCs, and Metals)	2,200.00	\$	11 baseline samples, assume \$200/sample
Laboratory Analysis (TPH and PAHs)	48,000.00	\$	240 samples, assume \$200/sample
Pre-characterization Analysis (TCLP)	2,800.00	\$	14 samples, assume \$200/sample
Confirmation Sampling	4,600.00	\$	23 samples, assume \$200/sample

RAO

Input Inventory Alternative 6B
 Site 4, Naval Weapons Industrial Reserve Plant
 Bethpage, New York
 Page 16 of 20

Transportation-Personnel			
Item	Quantity	Units	Comments
Field Labor (GW Sampling)	4,000.00	Miles	4 days/year, 10 years, 2 people, 50 miles/day

Laboratory Analytical Services			
Item	Quantity	Units	Comments
Laboratory Analysis (VOCs, SVOCs, and Metals)	22,000.00	\$	11 samples, 10 years, assume \$200/sample

Input Inventory Alternative 6B
 Site 4, Naval Weapons Industrial Reserve Plant
 Bethpage, New York
 Page 17 of 20

Alternative 6b:Excavation and Disposal of Soils (Soil TPH greater than 10,000 mg/Kg)

RI RAC			
Materials			
Item	Quantity	Units	Comments
Temporary Equipment Decon Pad Liner	700.47	lb	assume HDPE, Assume 30ftx40ft, 3 mm thick, 0.95 g/cm3
Temporary Equipment Decon Pad Frame	514.68	lb	Assume wood, 4x4 in, (30ftx40ft pad) 140 ft of timber, density for pine 530 kg/m3
Decon Water	5,000.00	gallons	Increased volume of water needed due to due numerous equipment required for alternative
Construction Entrance	166,666.67	lb	Assume 100 yd2 is needed for extrance, Assume 1 ft thick of gravel, 2.5 tons/CY
4 Material staging areas (10 ml poly/hay bales) ft)	5,280.00	lb	Used the following Material handling pad info to develop wieght. HDPE Liner, 5000 sf, 10 oz/sy, 16 oz/lb, 343.75 lbs
Backfill (off-site Source)	21,000,000.00	lbs	
Top Soil	90,000.00	lbs	30 yd3, Assume 1.5 ton/cy, 2000 lb/ton
Repaving (Stone)	169,650.00	lbs	260 yd2, Assume 6 inches thick, 145 lbs/ft3
Repaving (Asphalt)	84,825.00	lbs	260 yd2, Assume 3 inches thick, 145lbs/ft3
Revegetation seed	10.00	lb	
Monitoring Well Installation	115.20	lb	2 wells, Assume 80 ft depth, Assume 2 inch schedule 40 PVC pipe, 160 LF,0.72 lbs/ft

Transportation-Personnel			
Item	Quantity	Units	Comments
Field Labor (baseline sampling)	200.00	Miles	4 days, 50 miles/day, 1 person
Geologist	1,000.00	Miles	20 days, 50 miles/day
Construction Oversight (Supervisor, QC/H&S)	4,000.00	Miles	5 days/week, 2 months, 2 people, 50 miles/day
Operator and laborers (Assume 1 operators and 2 laboreres)	30,000.00	Miles	5 days/week, 10 months, 3 people, 50 miles/day
Construction Oversight (Supervisor, QC/H&S)	20,000.00	Miles	5 days/week, 10 months, 2 people, 50 miles/day
Well Installation (Geologist)	50.00	Miles	1 days, 50 miles/day, 1 person
Construction Oversight (Supervisor, QC/H&S)	4,000.00	Miles	5 days/week, 2 months, 2 people, 50 miles/day

Transportation-equipment			
Item	Quantity	Units	Comments
Drilling/Split Spoon	3.05	Ton	1 drill rig, 6100 lb, 100 miles round trip
Construction Facilities (trailer, utilities) - 10 months	6.00	Ton	Assume 3 tons, 2 trips
Site Prep (high vis fence, traffic control, E&S controls)	1.17	Ton	Assume 3 times the perimeter of excavation. Fence, 6 ft high chain link, 108 lb per 50 ft long, galvanized steel
Excavator 2.5 CY	20.00	ton	1 excavator, 20 ton per excavator, 100 miles round trip
Front End Loader	20.00	ton	1 Front End Loader, 20 ton , 100 miles round trip

Input Inventory Alternative 6B
 Site 4, Naval Weapons Industrial Reserve Plant
 Bethpage, New York
 Page 18 of 20

Clamshell Crane (Excavation lifting)	40.00 ton	1 clamshell Crane, 20 ton , 100 miles round trip
Crawler Crane (Sheet Piling)	40.00 ton	1 crawler crane, 20 ton , 100 miles round trip
Vibrator Hammer & Generator (Sheet Piling)	5.00 ton	5 ton , 100 miles round trip

Transportation-materials

Item	Quantity	Units	Comments
Temporary Equipment Decon Pad Liner	0.35 Ton		assume HDPE, Assume 30ftx40ft, 3 mm thick, 0.95 g/cm3
Temporary Equipment Decon Pad Frame	0.26 Ton		Assume wood, 4x4 in, (30ftx40ft pad) 140 ft of timber, density for pine 530 kg/m3
Site Prep (high vis fence, traffic control, E&S controls)	1.17 Ton		Assume 3 times the perimeter of excavation. Fence
Construction Entrance	83.33 Tons		100 yd2, Assume 1 ft thick of gravel, 2.5 tons/CY
Material staging area (10 ml poly/hay bales 160 ft X 120 ft)	2.64 Tons		Used the following Material handling pad info to develop wieght. HDPE Liner, 5000 sf, 10 oz/sy, 16 oz/lb, 343.75 lbs
Backfill (off-site Source)	10,500.00 Tons		
Repaving (Stone)	84.83 Tons		260 yd2, Assume 6 inches thick, 145 lbs/ft3
Repaving (Asphalt)	42.41 Tons		260 yd2, Assume 3 inches thick, 145lbs/ft3
Revegetation seed	0.01 Tons		
Monitoring Well Installation	0.06 Tons		2 wells, Assume 80 ft depth, Assume 2 inch schedule 40 PVC pipe, 160 LF,0.72 lbs/ft

Equipment Use

Item	Quantity	Units	Comments
Drilling/Split Spoon	38.40 Hours		30 borings, 5 borings /day, 8 hrs, 80% utility
Asphalt Removal (Excavator)	4.00 Hours		260 yd2, Assume 690 yd2/day,
Asphalt Removal (Loader)	4.00 Hours		260 yd2, Assume 690 yd2/day,
Sheet Piling (Crawler Crane)	92.44 Hours		Use FT2 of sheet piling needed. Assume 240 ft perimter. 71 ft bgs. 25 ft depth installation described in RS Means. Daily Output = 553 ft2/day. Multiply hours by 3 due complexity in driving to 71 bgs
Sheet Piling (Vibrator Hammer & Generator)	92.44 Hours		Consider time needed is same as above
Excavation (2.5 CY Excavator)	66.93 hours		8,000 CY, 765 CY/day, 80 utility
Excavation (Clamshell Crane)	66.93 hours		8,000 CY, 765 CY/day, 80 utility
Concrete UST Pad Removal and Disposal (2.5 CY Excavator)	1.15 hours		46 CY, 255 CY/day, 80 utility
Backfill of Soils for Reuse (6600 Cu Yds) Excavator	55.22 hours		6,600 CY, 765 CY/day, 80 utility
Backfill of Soils for Reuse (6600 Cu Yds) Clamshell Crane	55.22 hours		6,600 CY, 765 CY/day, 80 utility
Backfill (off-site Source) Excavator	11.71 hours		1400 CY, 765 CY/day, 80 utility
Backfill (off-site Source) Clamshell Crane	11.71 hours		1400 CY, 765 CY/day, 80 utility

Input Inventory Alternative 6B
 Site 4, Naval Weapons Industrial Reserve Plant
 Bethpage, New York
 Page 19 of 20

Grading (top soil)	2.08 Hours	Use 150ft X 150ft for Grading. Daily output 400 YD2
Asphalt Paving	0.73 Hours	560 yd2. Assume 3 inches. Daily output 4905 YD2
Material Staging Area Removal (Excavator)	8.00 Hours	Assume 1 day
General Construction Debris Removal (Excavator)	8.00 Hours	Assume 1 day

Residual Handling			
Item	Quantity	Units	Comments
Decon Water	20.85	Tons	5000 gallons, 8.34 lbs/gal Assume 2 inch schedule 40 PVC pipe, 150 LF, 0.72 lbs/ft
Well Removal	0.05	Tons	
Asphalt Removal	42.41	Tons	260 yd2, Assume 3 inches thick, 145lbs/ft3
Load, Transport, and Dispose	2,100.00	Tons	
Concrete UST Pad Removal and Disposal (2.5 CY Excavator)	115.00	Tons	46 yd3, Assume 2.5 ton/cy, 2000 lb/ton
Repaving (Stone)	182.70	Tons	560 yd2, Assume 6 inches thick, 145 lbs/ft3
Repaving (Asphalt)	91.35	Tons	560 yd2, Assume 3 inches thick, 145lbs/ft3
Material Staging Area Removal	2.64	Tons	Used the following Material handling pad info to develop wieght. HDPE Liner, 5000 sf, 10 oz/sy, 16 oz/lb, 343.75 lbs
General Construction Debris Removal	1.00	Tons	Assume 2000 lbs of General Construction Debris

Transportation-residual handling			
Item	Quantity	Units	Comments
Decon Water	150.00	miles	100 miles Assume 2 inch schedule 40 PVC pipe, 150 LF, 0.72 lbs/ft
Well Removal	150.00	miles	
Asphalt Removal	150.00	miles	260 yd2, Assume 3 inches thick, 145lbs/ft3
Load, Transport, and Dispose	150.00	miles	
Concrete UST Pad Removal and Disposal (2.5 CY Excavator)	150.00	miles	
Material Staging Area Removal	150.00	miles	Used the following Material handling pad info to develop wieght. HDPE Liner, 5000 sf, 10 oz/sy, 16 oz/lb, 343.75 lbs
General Construction Debris Removal	150.00	miles	Assume 2000 lbs of General Construction Debris

Laboratory Analytical Services			
Item	Quantity	Units	Comments
Laboratory Analysis (VOCs, SVOCs, and Metals)	2,200.00	\$	11 baseline samples, assume \$200/sample
Laboratory Analysis (TPH and PAHs)	48,000.00	\$	240 samples, assume \$200/sample
Pre-characterization Analysis (TCLP)	2,800.00	\$	14 samples, assume \$200/sample
Confirmation Sampling	4,600.00	\$	23 samples, assume \$200/sample

Input Inventory Alternative 6B
Site 4, Naval Weapons Industrial Reserve Plant
Bethpage, New York
Page 20 of 20

RAO

Transportation-Personnel

Item	Quantity	Units	Comments
Field Labor (GW Sampling)	4,000.00	Miles	4 days/year, 10 years, 2 people, 50 miles/day

Laboratory Analytical Services

Item	Quantity	Units	Comments
Laboratory Analysis (VOCs, SVOCs, and Metals)	22,000.00	\$	11 samples, 10 years, assume \$200/sample

APPENDIX E-3 SITEWISE™ RESULTS

**Sustainable Remediation - Environmental Footprint Summary
 Alternative 2**

Phase	Activities	GHG Emissions	Total energy Used	Water Consumption	NOx emissions	SOx Emissions	PM10 Emissions	Accident Risk Fatality	Accident Risk Injury
		metric ton	MMBTU	gallons	metric ton	metric ton	metric ton		
Remedial Investigation	Consumables	0.00	0.0E+00	NA	NA	NA	NA	NA	NA
	Transportation-Personnel	0.00	0.0E+00	NA	0.0E+00	0.0E+00	0.0E+00	0.0E+00	0.0E+00
	Transportation-Equipment	0.00	0.0E+00	NA	0.0E+00	0.0E+00	0.0E+00	0.0E+00	0.0E+00
	Equipment Use and Misc	0.00	0.0E+00	0.0E+00	0.0E+00	0.0E+00	0.0E+00	0.0E+00	0.0E+00
	Residual Handling	0.00	0.0E+00	NA	0.0E+00	0.0E+00	0.0E+00	0.0E+00	0.0E+00
	Sub-Total	0.00	0.00E+00	0.00E+00	0.00E+00	0.00E+00	0.00E+00	0.00E+00	0.00E+00
Remedial Action Construction	Consumables	0.00	0.0E+00	NA	NA	NA	NA	NA	NA
	Transportation-Personnel	0.00	0.0E+00	NA	0.0E+00	0.0E+00	0.0E+00	0.0E+00	0.0E+00
	Transportation-Equipment	0.00	0.0E+00	NA	0.0E+00	0.0E+00	0.0E+00	0.0E+00	0.0E+00
	Equipment Use and Misc	0.00	0.0E+00	0.0E+00	0.0E+00	0.0E+00	0.0E+00	0.0E+00	0.0E+00
	Residual Handling	0.00	0.0E+00	NA	0.0E+00	0.0E+00	0.0E+00	0.0E+00	0.0E+00
	Sub-Total	0.00	0.00E+00	0.00E+00	0.00E+00	0.00E+00	0.00E+00	0.00E+00	0.00E+00
Remedial Action Operations	Consumables	0.00	0.0E+00	NA	NA	NA	NA	NA	NA
	Transportation-Personnel	0.00	0.0E+00	NA	0.0E+00	0.0E+00	0.0E+00	0.0E+00	0.0E+00
	Transportation-Equipment	0.00	0.0E+00	NA	0.0E+00	0.0E+00	0.0E+00	0.0E+00	0.0E+00
	Equipment Use and Misc	0.00	0.0E+00	0.0E+00	0.0E+00	0.0E+00	0.0E+00	0.0E+00	0.0E+00
	Residual Handling	0.00	0.0E+00	NA	0.0E+00	0.0E+00	0.0E+00	0.0E+00	0.0E+00
	Sub-Total	0.00	0.00E+00	0.00E+00	0.00E+00	0.00E+00	0.00E+00	0.00E+00	0.00E+00
Longterm Monitoring	Consumables	0.00	0.0E+00	NA	NA	NA	NA	NA	NA
	Transportation-Personnel	7.55	9.5E+01	NA	2.8E-03	9.8E-05	5.7E-04	1.5E-04	1.2E-02
	Transportation-Equipment	0.14	2.0E+00	NA	4.6E-05	1.9E-06	3.7E-06	7.8E-07	6.3E-05
	Equipment Use and Misc	47.23	7.2E+02	0.0E+00	1.7E-01	1.1E-01	5.3E-03	7.0E-06	1.8E-03
	Residual Handling	0.00	0.0E+00	NA	0.0E+00	0.0E+00	0.0E+00	0.0E+00	0.0E+00
	Sub-Total	54.91	8.15E+02	0.00E+00	1.75E-01	1.06E-01	5.89E-03	1.62E-04	1.43E-02
Total		5.5E+01	8.2E+02	0.0E+00	1.7E-01	1.1E-01	5.9E-03	1.6E-04	1.4E-02

Remedial Alternative Phase	Non-Hazardous Waste Landfill Space	Hazardous Waste Landfill Space	Topsoil Consumption	Costing	Lost Hours - Injury
	tons	tons	cubic yards	\$	
Remedial Investigation	0.0E+00	0.0E+00	0.0E+00	0	0.0E+00
Remedial Action Construction	0.0E+00	0.0E+00	0.0E+00	0	0.0E+00
Remedial Action Operations	0.0E+00	0.0E+00	0.0E+00	0	0.0E+00
Longterm Monitoring	0.0E+00	0.0E+00	0.0E+00	0	1.1E-01
Total	0.0E+00	0.0E+00	0.0E+00	\$0	1.1E-01

Total Cost with Footprint Reduction
\$0

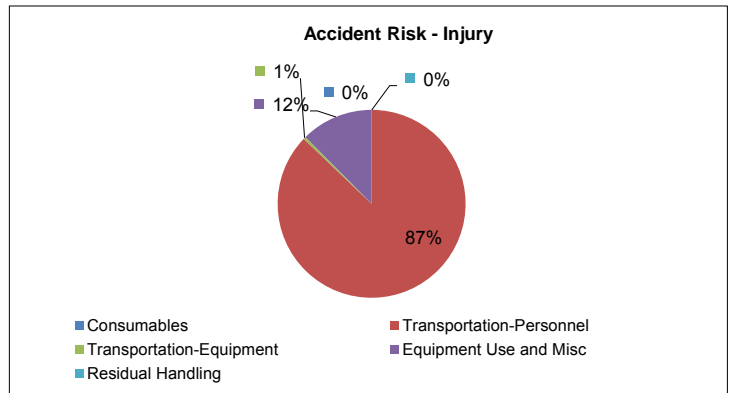
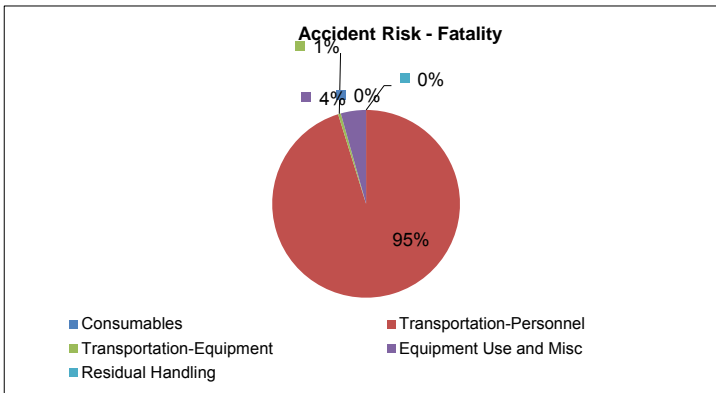
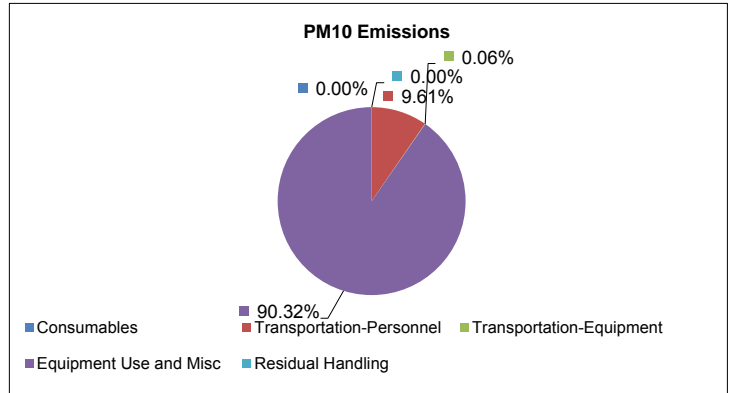
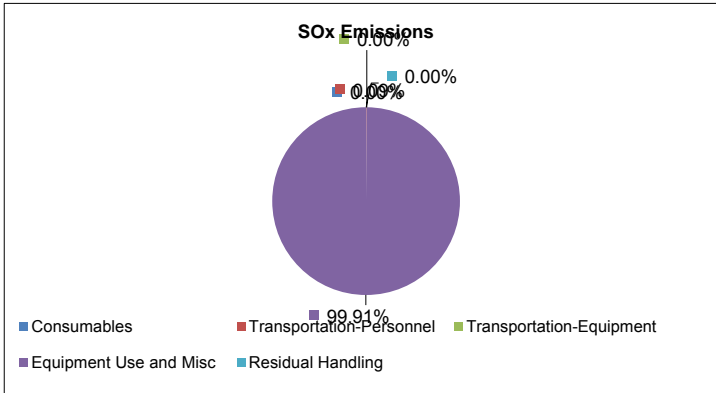
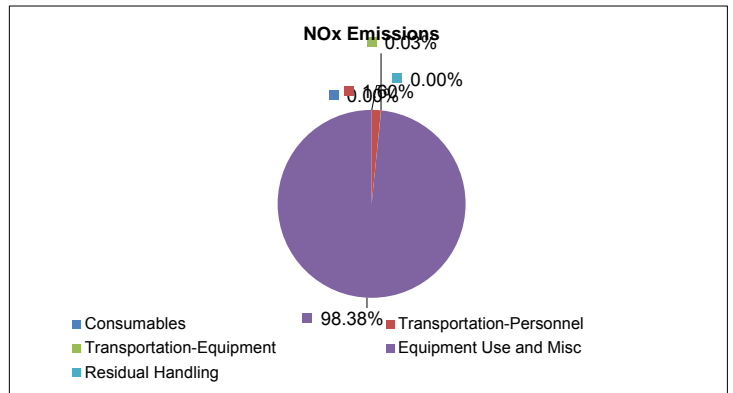
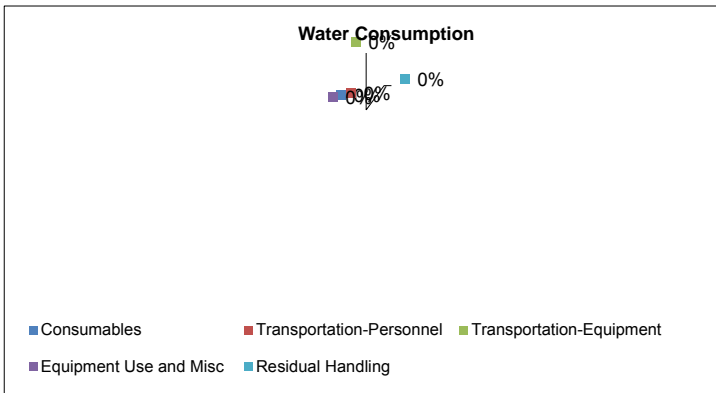
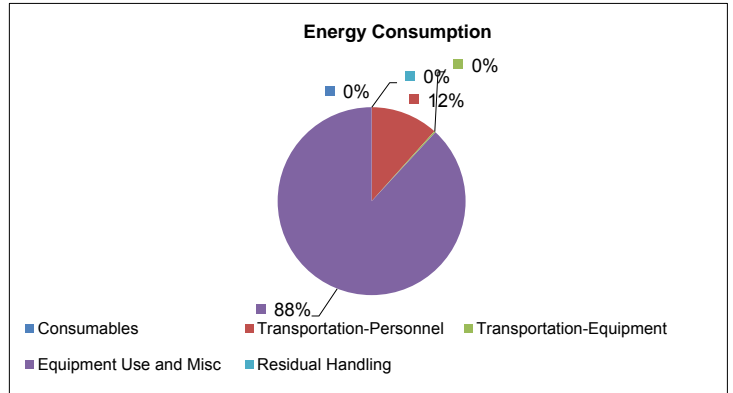
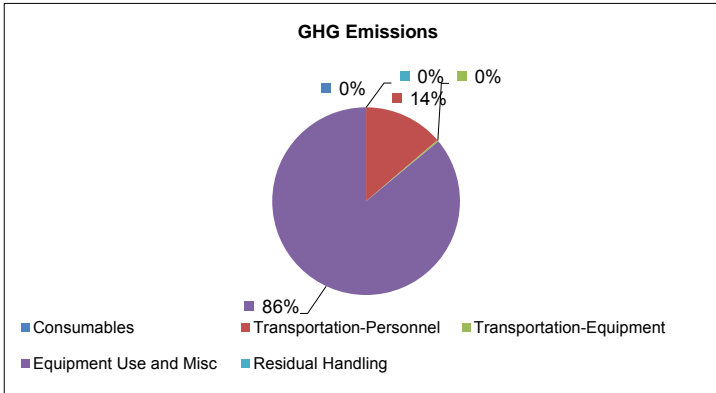

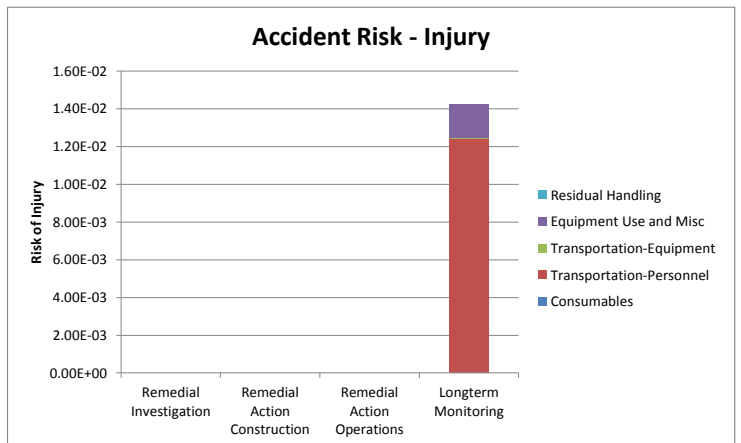
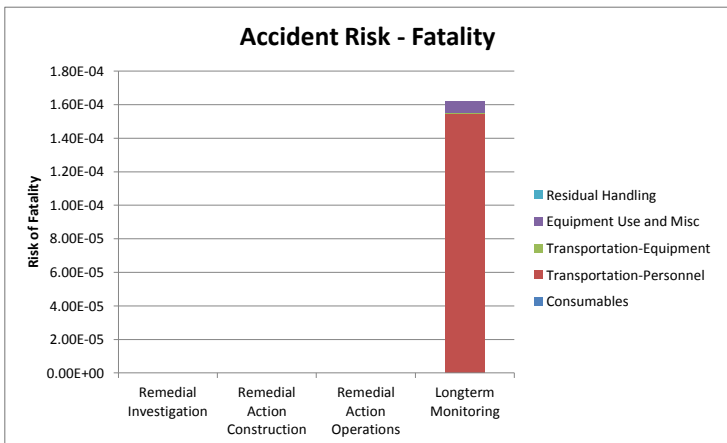
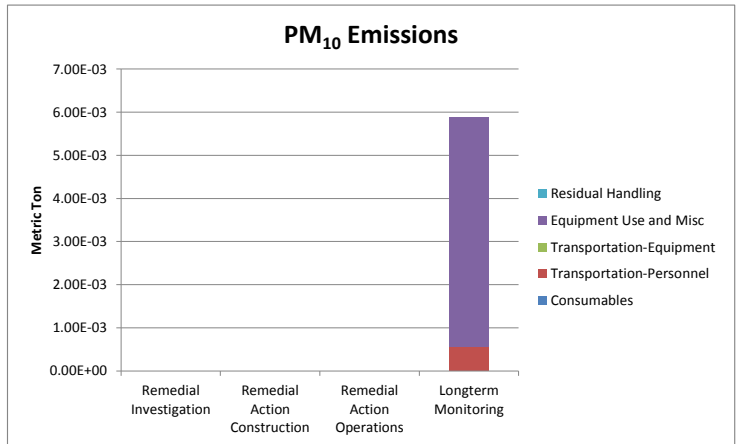
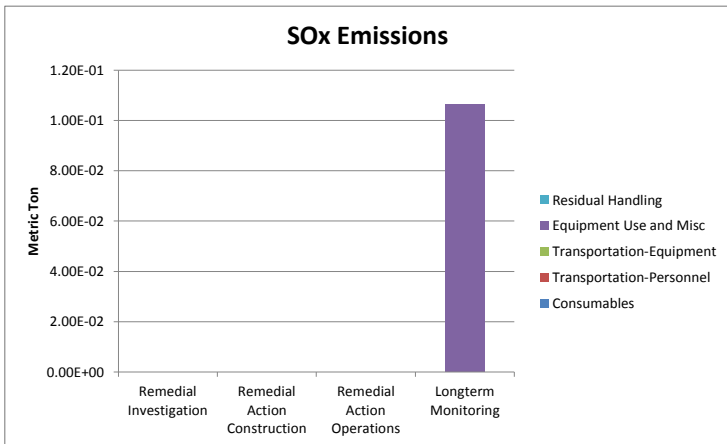
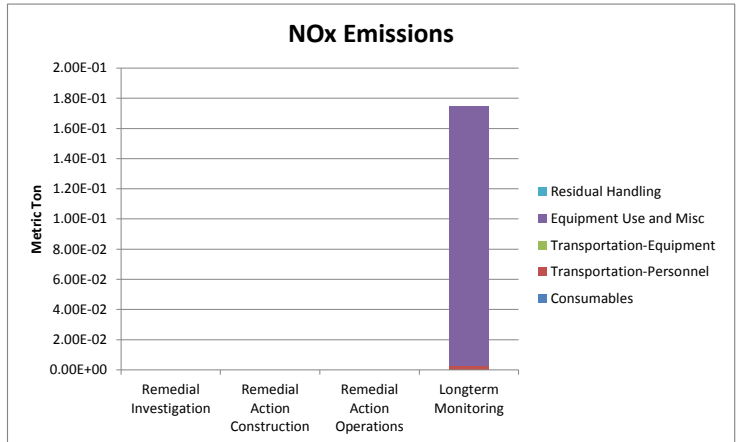
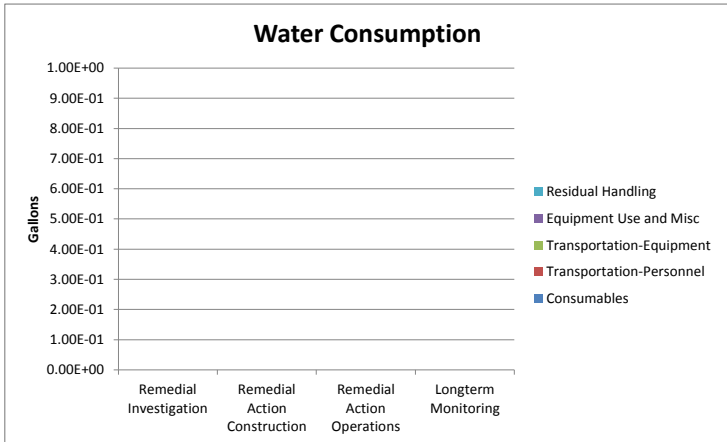
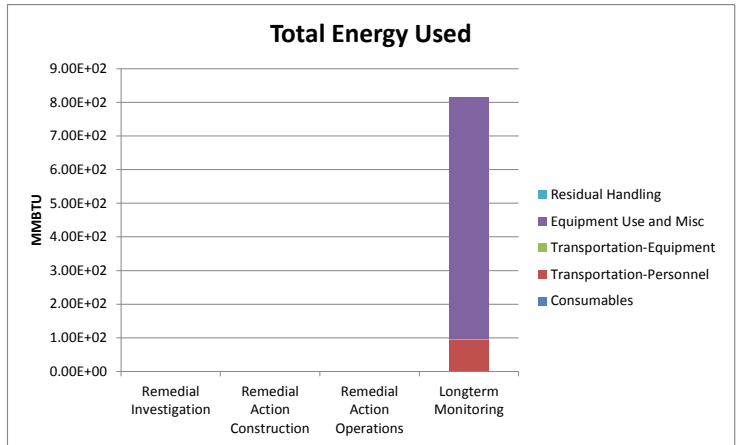
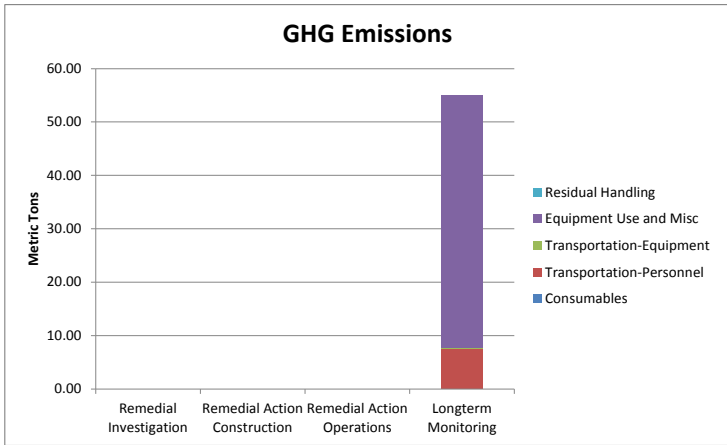

Technology Module / Phase	Module Components	Comments / Assumptions	Quantity	(Units)	Greenhouse Gas Emissions				Criteria Pollutant Emission			Energy Consumption	Water Consumption	
					CO ₂ e	CO ₂	N ₂ O	CH ₄	NO _x	SO _x	PM ₁₀	MW hr	gal x 1000	
Stage Materials												MW hr	gal x 1000	
Subtotal					0.00	0.00	0.00	0.00	0.00	0.00	0.00	0.00	0	
Construction Equipment												MW hr	gal x 1000	
LTM	Drilling/Split Spoon to 70 ft (4 borings)	Drill Rig, DPT (diesel)	4 days every 10 years, 3 events, 80% usage	76.8	hrs	1.23	1.20	0.00	0.00	0.01	0.00	0.00	9.39	
Subtotal					1.23	1.20	0.00	0.00	0.01	0.00	0.00	9.39	0	
Total					1	1	0.00	0.00	0.01	0.00	0.00	9	0	



Alternative 1
 Values Input into SiteWise as "Other"

Module	Greenhouse Gas Emissions				Criteria Pollutant Emission			Energy Consumption	Water Consumption
	CO ₂ e	CO ₂	N ₂ O (CO ₂ e)	CH ₄ (CO ₂ e)	NO _x	SO _x	PM ₁₀	MMBTU	gal
RI	-	-	-	-	-	-	-	-	-
RAC	-	-	-	-	-	-	-	-	-
RAO	-	-	-	-	-	-	-	-	-
LTM	1.23	1.20	-	0.03	0.01	0.00	0.00	32.02	-

Note: 1 MW hr = 3412141.4799 BTU, 1MMBTU = 10*6 BTU

**Sustainable Remediation - Environmental Footprint Summary
 Alternative 3**

Phase	Activities	GHG Emissions	Total energy Used	Water Consumption	NOx emissions	SOx Emissions	PM10 Emissions	Accident Risk Fatality	Accident Risk Injury
		metric ton	MMBTU	gallons	metric ton	metric ton	metric ton		
Remedial Investigation	Consumables	0.00	0.0E+00	NA	NA	NA	NA	NA	NA
	Transportation-Personnel	0.00	0.0E+00	NA	0.0E+00	0.0E+00	0.0E+00	0.0E+00	0.0E+00
	Transportation-Equipment	0.00	0.0E+00	NA	0.0E+00	0.0E+00	0.0E+00	0.0E+00	0.0E+00
	Equipment Use and Misc	0.00	0.0E+00	0.0E+00	0.0E+00	0.0E+00	0.0E+00	0.0E+00	0.0E+00
	Residual Handling	0.00	0.0E+00	NA	0.0E+00	0.0E+00	0.0E+00	0.0E+00	0.0E+00
	Sub-Total	0.00	0.00E+00	0.00E+00	0.00E+00	0.00E+00	0.00E+00	0.00E+00	0.00E+00
Remedial Action Construction	Consumables	0.00	0.0E+00	NA	NA	NA	NA	NA	NA
	Transportation-Personnel	8.84	1.1E+02	NA	3.3E-03	1.2E-04	6.6E-04	1.8E-04	1.5E-02
	Transportation-Equipment	0.60	7.8E+00	NA	1.9E-04	3.3E-06	1.7E-05	1.6E-06	1.3E-04
	Equipment Use and Misc	23.27	1.0E+03	3.3E+03	1.7E-02	2.0E-02	1.9E-03	3.7E-06	9.2E-04
	Residual Handling	0.15	1.9E+00	NA	4.7E-05	8.3E-07	4.2E-06	7.8E-07	6.3E-05
	Sub-Total	32.86	1.12E+03	3.34E+03	2.10E-02	1.96E-02	2.56E-03	1.87E-04	1.57E-02
Remedial Action Operations	Consumables	0.00	0.0E+00	NA	NA	NA	NA	NA	NA
	Transportation-Personnel	11.28	1.4E+02	NA	4.2E-03	1.5E-04	8.5E-04	2.3E-04	1.9E-02
	Transportation-Equipment	0.23	3.0E+00	NA	7.2E-05	1.9E-06	6.2E-06	1.2E-06	9.4E-05
	Equipment Use and Misc	557.98	9.4E+03	9.2E+05	1.1E+00	5.6E-01	8.8E-03	9.4E-07	2.4E-04
	Residual Handling	0.64	8.5E+00	NA	2.0E-04	5.4E-06	1.7E-05	2.3E-06	1.9E-04
	Sub-Total	570.13	9.51E+03	9.23E+05	1.07E+00	5.56E-01	9.64E-03	2.35E-04	1.91E-02
Longterm Monitoring	Consumables	0.00	0.0E+00	NA	NA	NA	NA	NA	NA
	Transportation-Personnel	0.00	0.0E+00	NA	0.0E+00	0.0E+00	0.0E+00	0.0E+00	0.0E+00
	Transportation-Equipment	0.00	0.0E+00	NA	0.0E+00	0.0E+00	0.0E+00	0.0E+00	0.0E+00
	Equipment Use and Misc	0.00	0.0E+00	0.0E+00	0.0E+00	0.0E+00	0.0E+00	0.0E+00	0.0E+00
	Residual Handling	0.00	0.0E+00	NA	0.0E+00	0.0E+00	0.0E+00	0.0E+00	0.0E+00
	Sub-Total	0.00	0.00E+00	0.00E+00	0.00E+00	0.00E+00	0.00E+00	0.00E+00	0.00E+00
Total		6.0E+02	1.1E+04	9.3E+05	1.1E+00	5.8E-01	1.2E-02	4.2E-04	3.5E-02

Remedial Alternative Phase	Non-Hazardous Waste Landfill Space	Hazardous Waste Landfill Space	Topsoil Consumption	Costing	Lost Hours - Injury
	tons	tons	cubic yards	\$	
Remedial Investigation	0.0E+00	0.0E+00	0.0E+00	0	0.0E+00
Remedial Action Construction	0.0E+00	0.0E+00	0.0E+00	0	1.3E-01
Remedial Action Operations	0.0E+00	0.0E+00	0.0E+00	0	1.5E-01
Longterm Monitoring	0.0E+00	0.0E+00	0.0E+00	0	0.0E+00
Total	0.0E+00	0.0E+00	0.0E+00	\$0	2.8E-01

Total Cost with Footprint Reduction
\$0

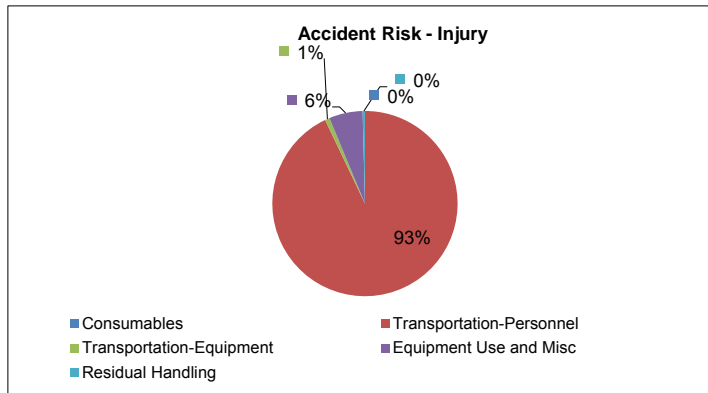
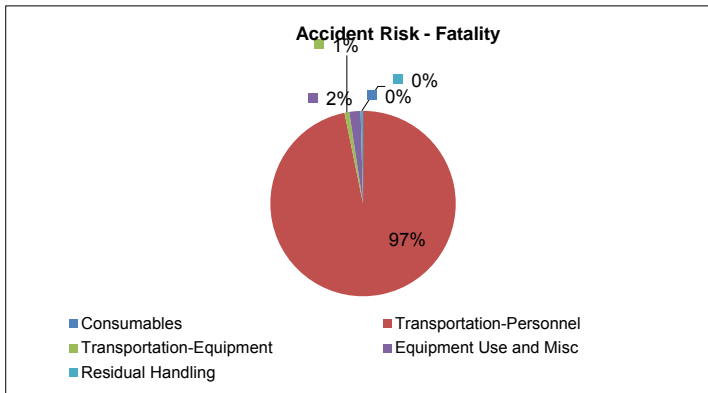
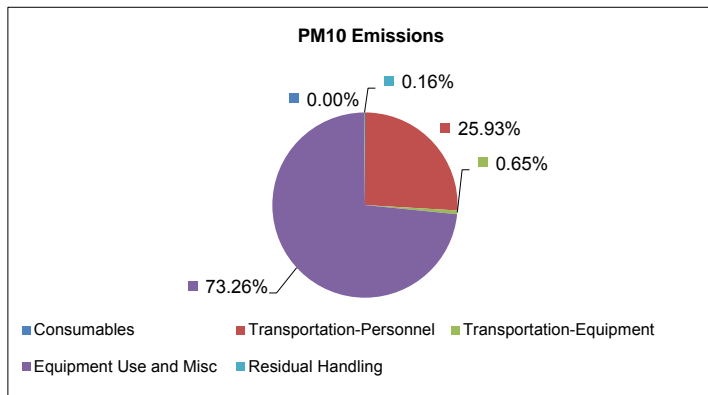
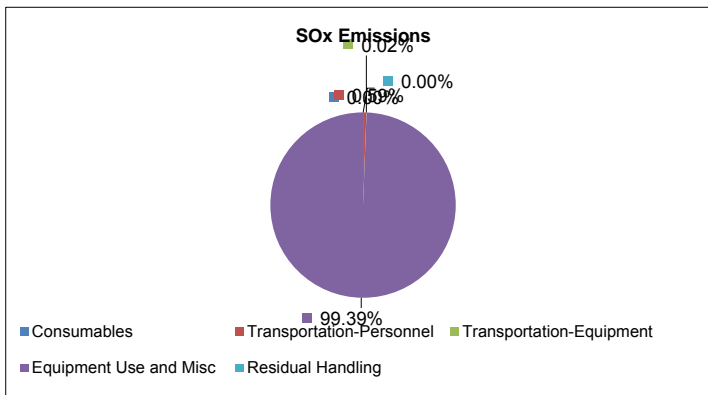
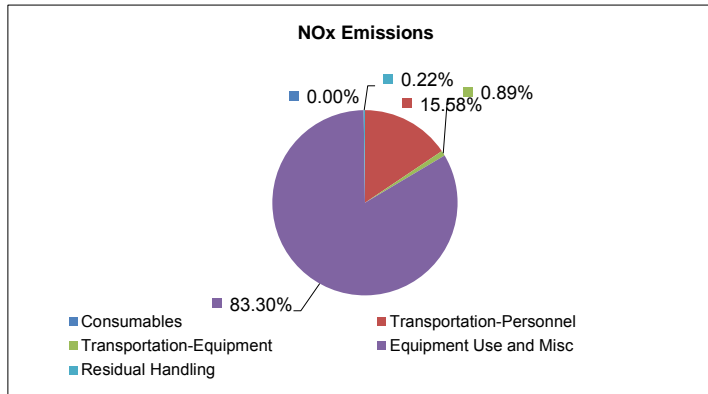
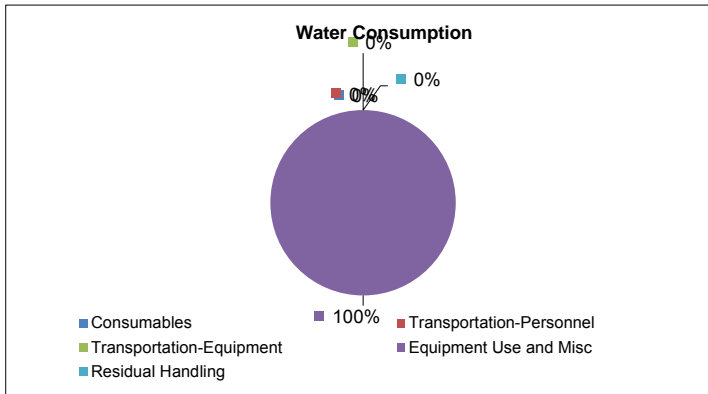
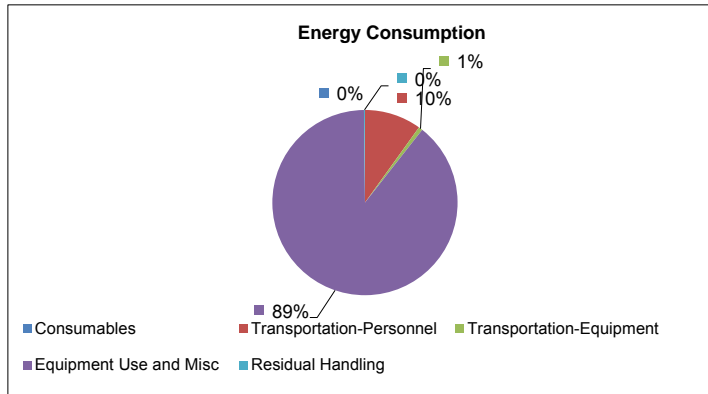
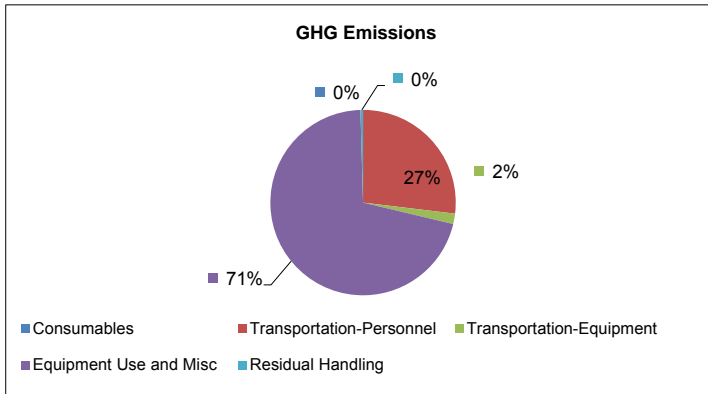

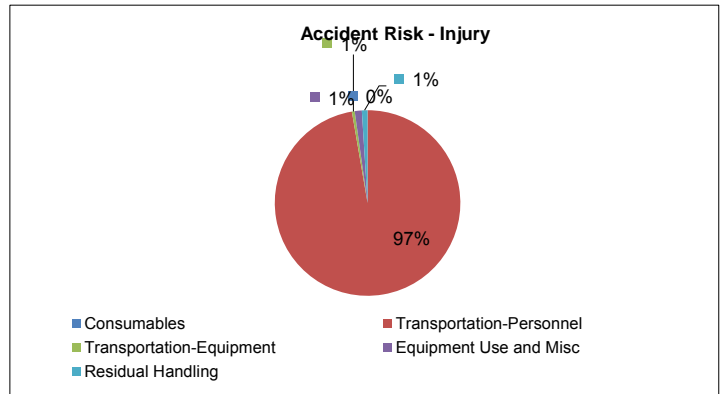
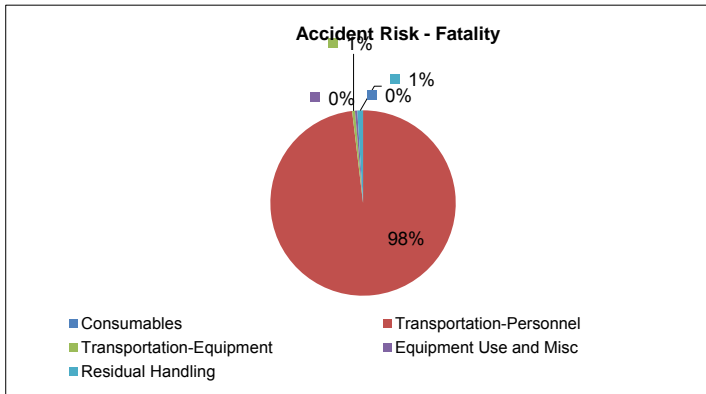
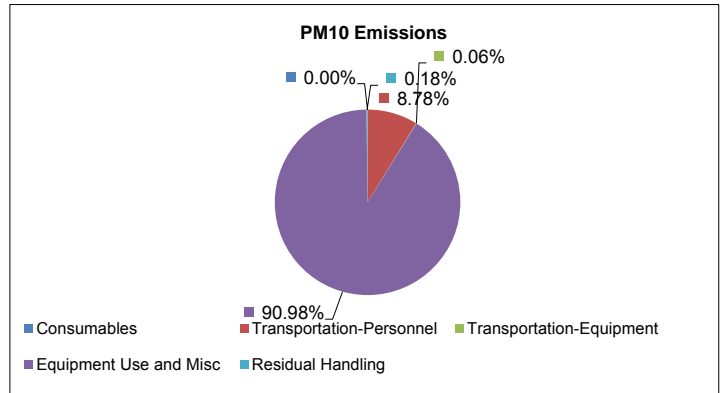
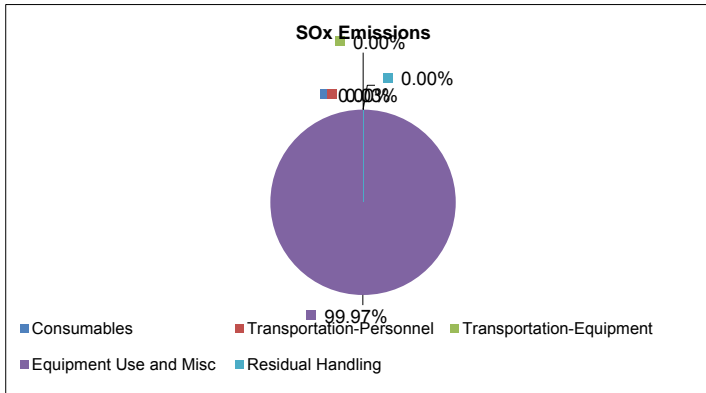
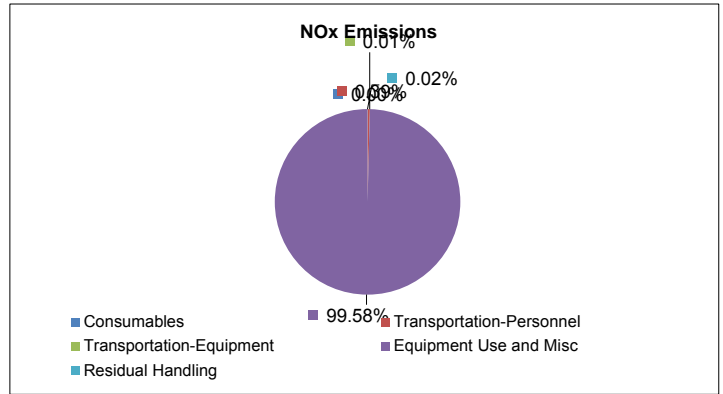
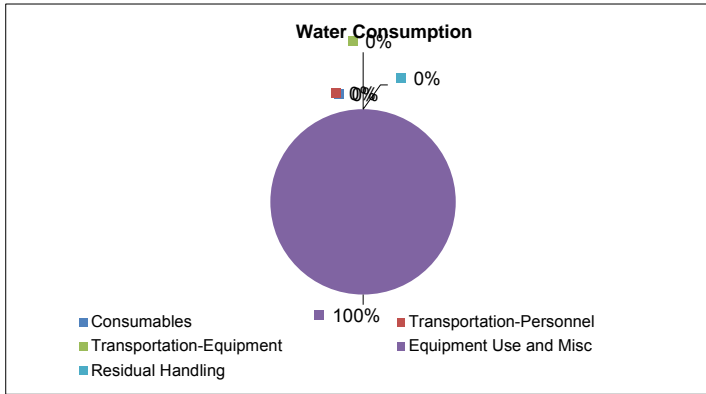
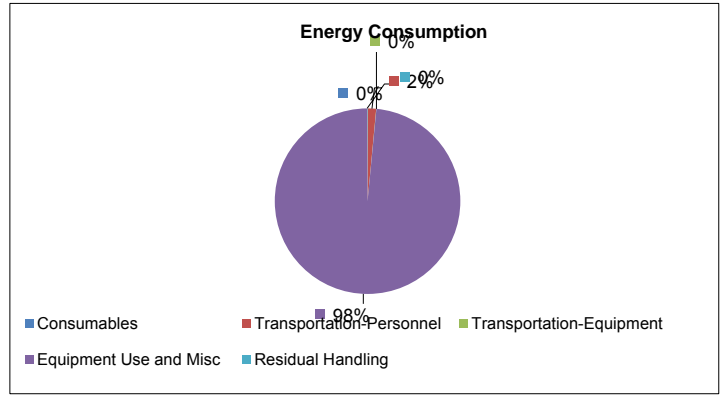
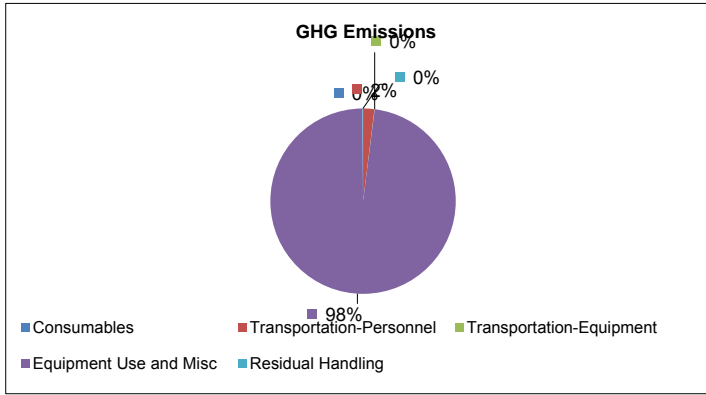

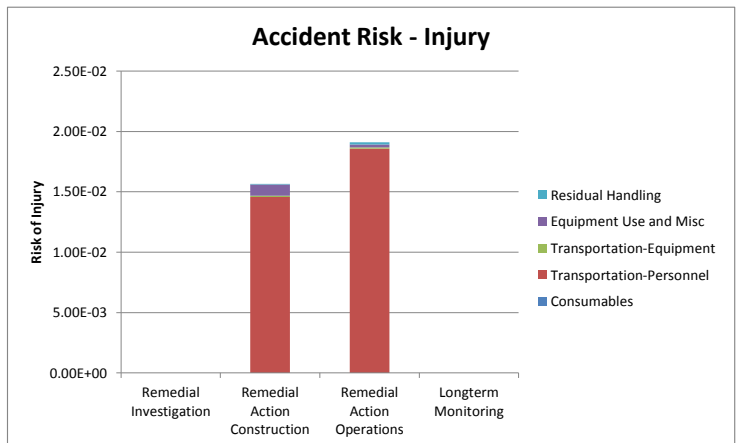
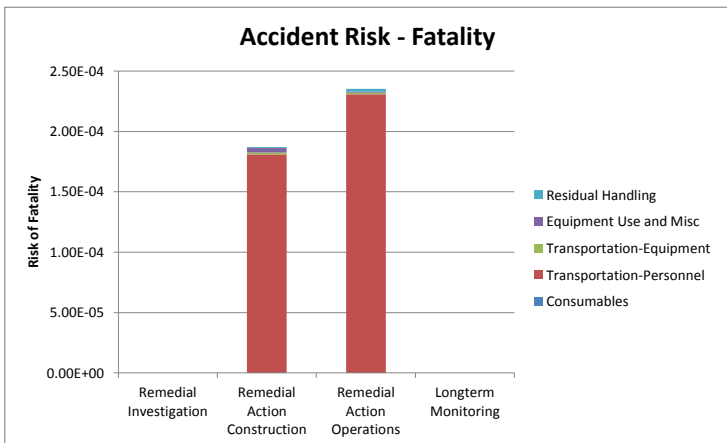
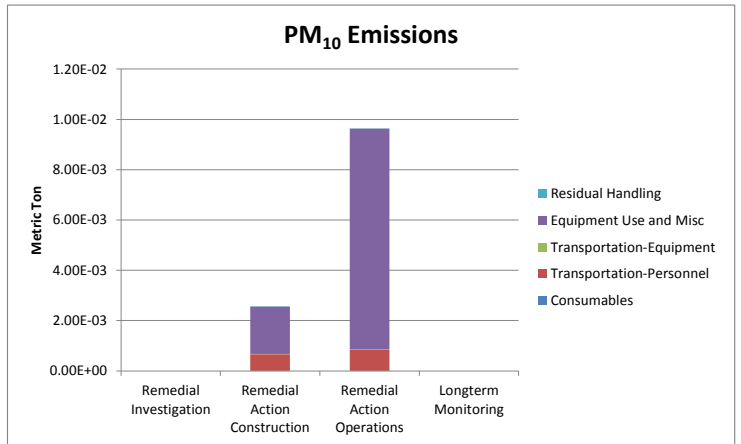
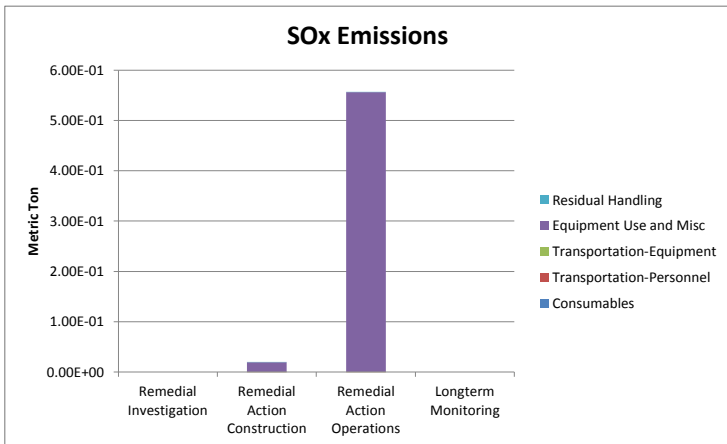
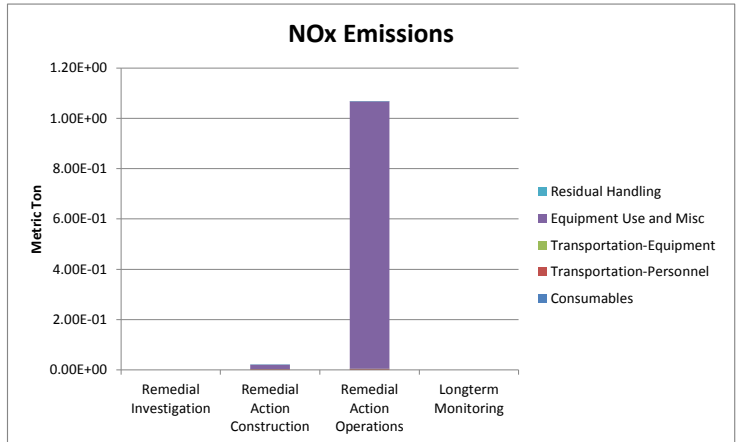
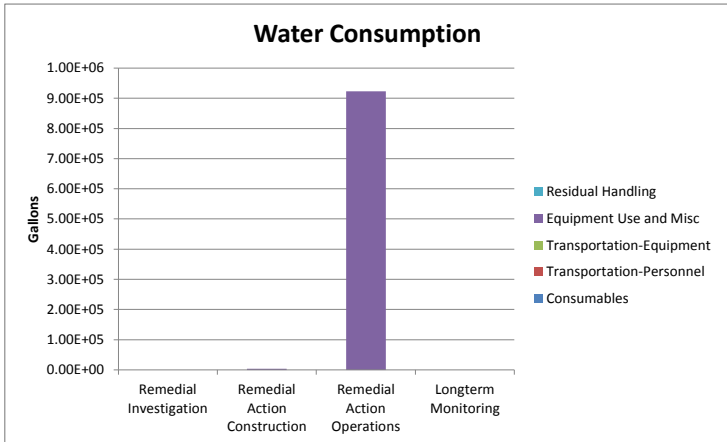
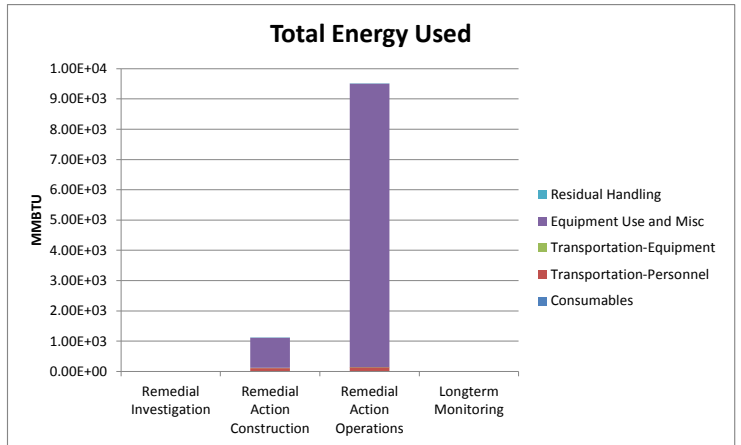
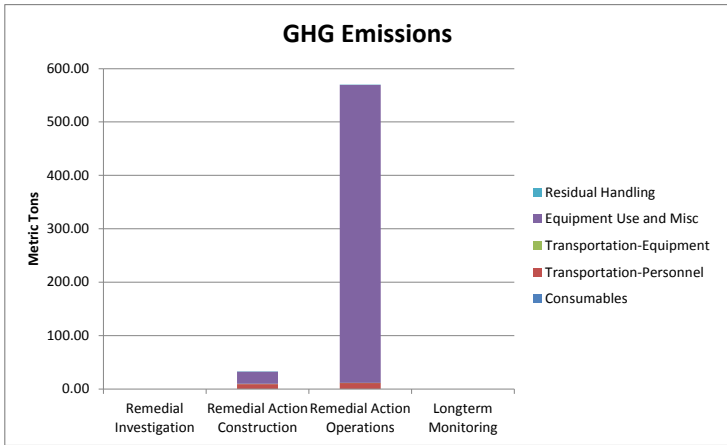

Stage	Technology Module / Phase	Module Components	Comments / Assumptions	Quantity	(Units)	Greenhouse Gas Emissions				Criteria Pollutant Emission			Energy Consumption	Water Consumption
						CO ₂ e	CO ₂	N ₂ O	CH ₄	NO _x	SO _x	PM ₁₀		
						Tonnes								
												MWhr	gal x 1000	
	Materials													
RAC	1" Injection Wells (14 Clusters - 12 at 50 and 60, 4 at 70 feet)	Steel	1 inch carbon steel pipe, 1580 LF, 1.68 lbs/ft	1,580.00	lft	3.38	3.25	0.00	0.00	0.00	0.00	0.00	56.00	1.42
RAC	Steam Injection Piping (2 inch steel - underground)	Steel	2 inch carbon steel pipe, 280 LF, 3.65 lbs/ft	280.00	lft	1.30	1.25	0.00	0.00	0.00	0.00	0.00	21.56	0.25
RAC	6" Product Recovery Wells (5 at 60 feet)	Steel	6 inch carbon steel pipe, 300 LF, 18.97 lbs/ft	300.00	lft	7.25	6.97	0.00	0.00	0.00	0.01	0.00	120.06	0.27
RAC	Product Recovery Piping	Steel	2 inch carbon steel pipe, 165 LF, 3.65 lbs/ft	165.00	lft	0.77	0.74	0.00	0.00	0.00	0.00	0.00	12.71	0.15
RAC	Temporary Equipment Decon Pad Liner	HDPE	assume HDPE, Assume 30ftx40ft, 3 mm thick, 0.95 g/cm3	700.47	lbs	1.56	0.83	0.00	0.01	0.00	0.00	0.00	9.17	0.25
RAC	Temporary Equipment Decon Pad Frame	Wood	Assume wood, 4x4 in, (30ftx40ft pad) 140 ft of timber, density for pine 530 kg/m3	514.68	lbs	0.01	0.01	0.00	0.00	0.00	0.00	0.00	0.01	0.00
RAC	Building & Footing	General Concrete	assume block building with foundation, 600 ft2, Consider only concrete, weight of 0.5 ft of poured concrete 145 lb/ft2, 41 bags of cement	45,960.00	lbs	2.71	2.71	0.00	0.00	0.00	0.00	0.00	26.75	0.00
RAC	Building & Footing	General Concrete	Assume 12 ft high walls at 100 LF. 1350 blocks (40 lb/ea),	54,000.00	lbs	3.18	3.18	0.00	0.00	0.00	0.00	0.00	31.42	0.00
RAC	Building & Footing	Sand	4.72 tons of sand	9,440.00	lbs	0.02	0.02	0.00	0.00	0.00	0.00	0.00	0.58	0.00
RAO	GAC (Liquid & Vapor)	Regenerated GAC	5000 lbs/year, 4 years operation, assume reactivated GAC	20,000.00	lbs	17.14	17.14	0.00	0.00	0.00	0.00	0.00	171.51	0.00
						37.33	36.10	0.00	0.01	7.53E-04	0.01	5.08E-04	449.76	2.34
	Subtotal													
													MWhr	gal x 1000
	Construction Equipment													
RAC	Excavator (building construction), 2.5 CY	Excavator, Hydraulic, 2 CY (diesel)	excavate 600 ft2, 1 ft deep, 600 ft3/27cy= 22.2 cy, Assume 10 cy/day, 8 hrs/day, 80% utility	14.21	hrs	1.38	1.38	0.00	0.00	0.01	0.00	0.00	6.25	
RAC	DPT Drill Rig (Air & Steam Injection wells)	Drill Rig, DPT (diesel)	20 wells, 5 wells/day, 8 hrs, 80% utility	25.60	hrs	0.41	0.40	0.00	0.00	0.00	0.00	0.00	3.13	
RAO	Drilling/Split Spoon to 70 ft (4 borings)	Drill Rig, DPT (diesel)	Assume 0.5 day	5.00	hrs	0.08	0.08	0.00	0.00	0.00	0.00	0.00	0.61	
	Subtotal					1.87	1.86	0.00	0.00	0.01	0.00	0.00	9.99	0
						39	38	0.00	0.01	0.01	0.02	0.00	460	2



Alternative 1
 Values Input into SiteWise as "Other"

Module	Greenhouse Gas Emissions				Criteria Pollutant Emission			Energy Consumption	Water Consumption
	CO ₂ e	CO ₂	N ₂ O (CO ₂ e)	CH ₄ (CO ₂ e)	NO _x	SO _x	PM ₁₀		
								MMBTU	gal
RI	-	-	-	-	-	-	-	-	-
RAC	21.97	20.73	1.03	0.21	0.01	0.02	0.00	981.36	2,344.67
RAO	17.22	17.22	-	0.00	0.00	0.00	0.00	587.29	-
LTM	-	-	-	-	-	-	-	-	-

Note: 1 MWhr = 3412141.4799 BTU, 1MMBTU = 10⁶ BTU

**Sustainable Remediation - Environmental Footprint Summary
 Alternative 4**

Phase	Activities	GHG Emissions	Total energy Used	Water Consumption	NOx emissions	SOx Emissions	PM10 Emissions	Accident Risk Fatality	Accident Risk Injury
		metric ton	MMBTU	gallons	metric ton	metric ton	metric ton		
Remedial Investigation	Consumables	0.00	0.0E+00	NA	NA	NA	NA	NA	NA
	Transportation-Personnel	0.00	0.0E+00	NA	0.0E+00	0.0E+00	0.0E+00	0.0E+00	0.0E+00
	Transportation-Equipment	0.00	0.0E+00	NA	0.0E+00	0.0E+00	0.0E+00	0.0E+00	0.0E+00
	Equipment Use and Misc	0.00	0.0E+00	0.0E+00	0.0E+00	0.0E+00	0.0E+00	0.0E+00	0.0E+00
	Residual Handling	0.00	0.0E+00	NA	0.0E+00	0.0E+00	0.0E+00	0.0E+00	0.0E+00
	Sub-Total	0.00	0.00E+00	0.00E+00	0.00E+00	0.00E+00	0.00E+00	0.00E+00	0.00E+00
Remedial Action Construction	Consumables	0.00	0.0E+00	NA	NA	NA	NA	NA	NA
	Transportation-Personnel	9.22	1.2E+02	NA	3.4E-03	1.2E-04	6.9E-04	1.9E-04	1.5E-02
	Transportation-Equipment	0.59	8.0E+00	NA	1.9E-04	7.7E-06	1.5E-05	1.6E-06	1.3E-04
	Equipment Use and Misc	15.75	5.8E+02	2.8E+03	1.8E-02	1.3E-02	1.9E-03	3.8E-06	9.4E-04
	Residual Handling	0.22	2.9E+00	NA	7.0E-05	1.2E-06	6.3E-06	1.2E-06	9.4E-05
	Sub-Total	25.78	7.02E+02	2.78E+03	2.14E-02	1.35E-02	2.61E-03	1.95E-04	1.64E-02
Remedial Action Operations	Consumables	0.00	0.0E+00	NA	NA	NA	NA	NA	NA
	Transportation-Personnel	8.54	1.1E+02	NA	3.2E-03	1.1E-04	6.4E-04	1.7E-04	1.4E-02
	Transportation-Equipment	0.22	3.0E+00	NA	7.0E-05	2.8E-06	5.7E-06	1.2E-06	9.4E-05
	Equipment Use and Misc	201.78	5.3E+03	4.9E+05	2.9E-01	6.7E-01	5.0E-03	9.4E-07	2.4E-04
	Residual Handling	0.57	7.8E+00	NA	1.8E-04	7.5E-06	1.5E-05	2.3E-06	1.9E-04
	Sub-Total	211.10	5.42E+03	4.88E+05	2.90E-01	6.69E-01	5.61E-03	1.79E-04	1.46E-02
Longterm Monitoring	Consumables	0.00	0.0E+00	NA	NA	NA	NA	NA	NA
	Transportation-Personnel	0.00	0.0E+00	NA	0.0E+00	0.0E+00	0.0E+00	0.0E+00	0.0E+00
	Transportation-Equipment	0.00	0.0E+00	NA	0.0E+00	0.0E+00	0.0E+00	0.0E+00	0.0E+00
	Equipment Use and Misc	0.00	0.0E+00	0.0E+00	0.0E+00	0.0E+00	0.0E+00	0.0E+00	0.0E+00
	Residual Handling	0.00	0.0E+00	NA	0.0E+00	0.0E+00	0.0E+00	0.0E+00	0.0E+00
	Sub-Total	0.00	0.00E+00	0.00E+00	0.00E+00	0.00E+00	0.00E+00	0.00E+00	0.00E+00
Total		2.4E+02	6.1E+03	4.9E+05	3.1E-01	6.8E-01	8.2E-03	3.7E-04	3.1E-02

Remedial Alternative Phase	Non-Hazardous Waste Landfill Space	Hazardous Waste Landfill Space	Topsoil Consumption	Costing	Lost Hours - Injury
	tons	tons	cubic yards	\$	
Remedial Investigation	0.0E+00	0.0E+00	0.0E+00	0	0.0E+00
Remedial Action Construction	0.0E+00	0.0E+00	0.0E+00	0	1.3E-01
Remedial Action Operations	0.0E+00	0.0E+00	0.0E+00	0	1.2E-01
Longterm Monitoring	0.0E+00	0.0E+00	0.0E+00	0	0.0E+00
Total	0.0E+00	0.0E+00	0.0E+00	\$0	2.5E-01

Total Cost with Footprint Reduction
\$0

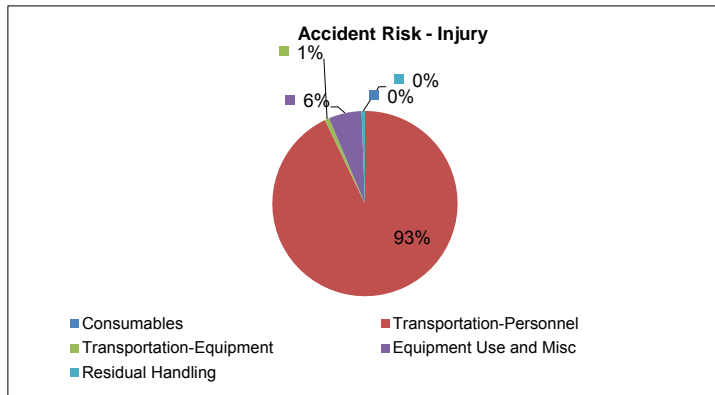
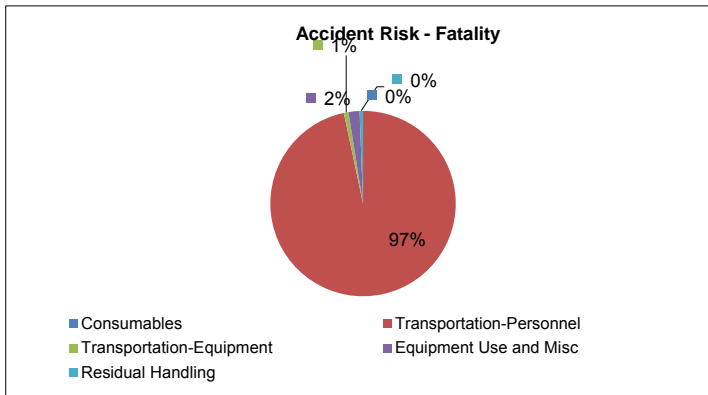
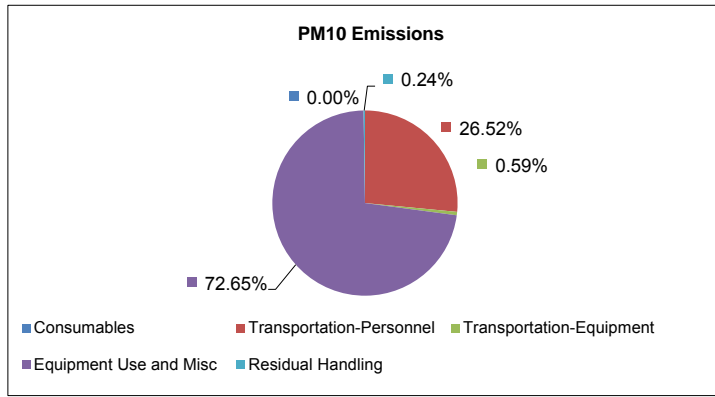
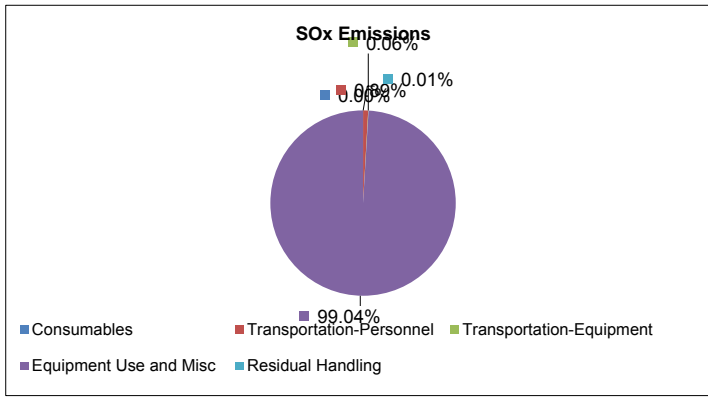
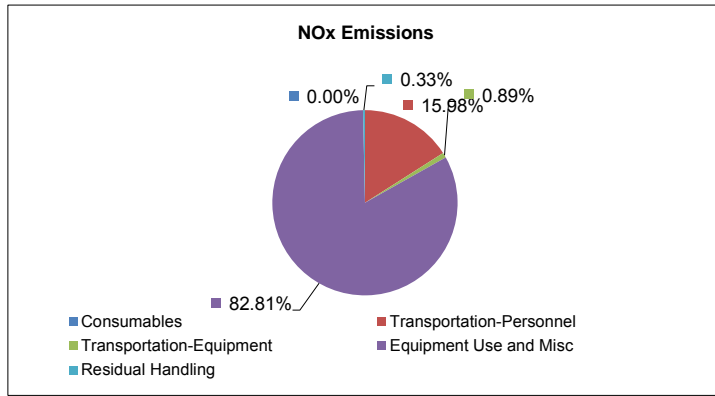
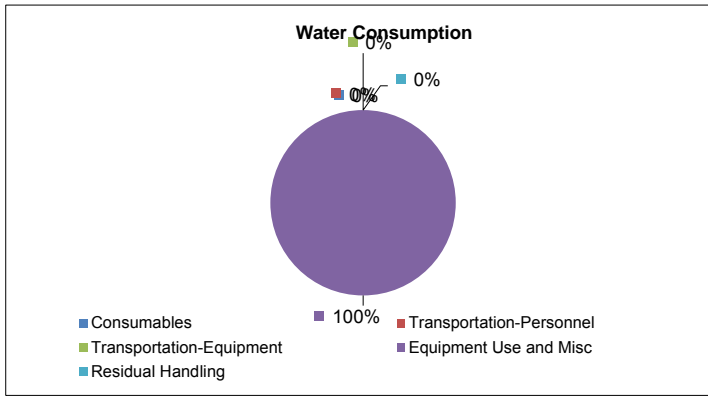
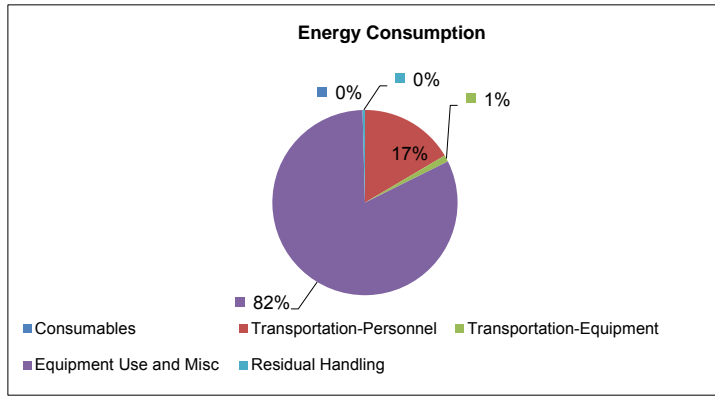
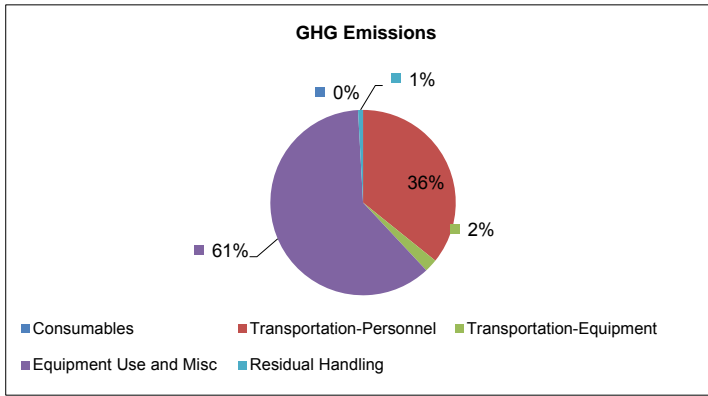

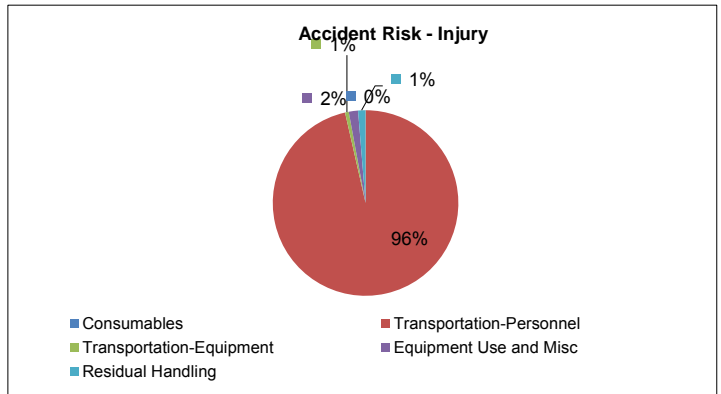
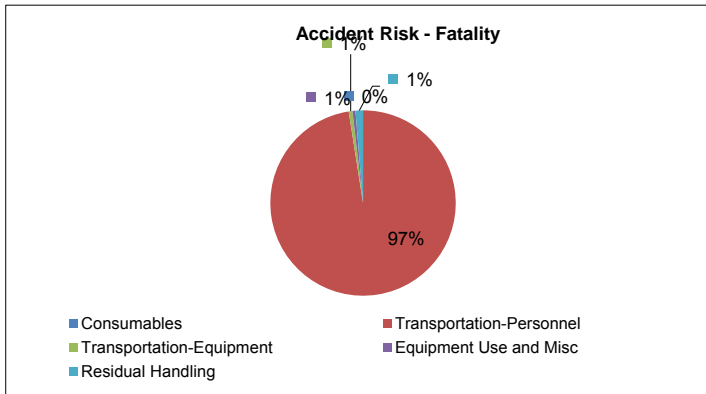
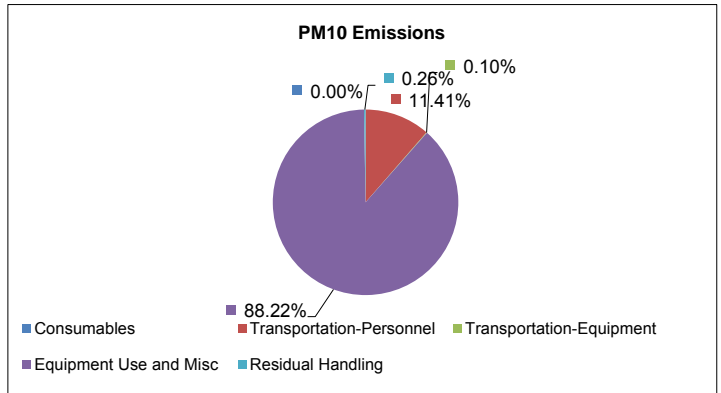
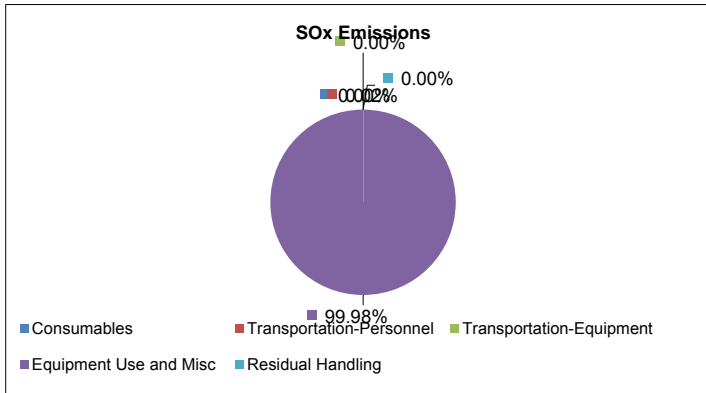
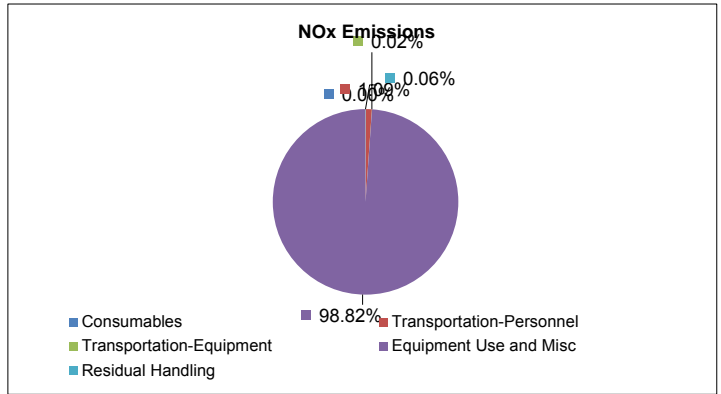
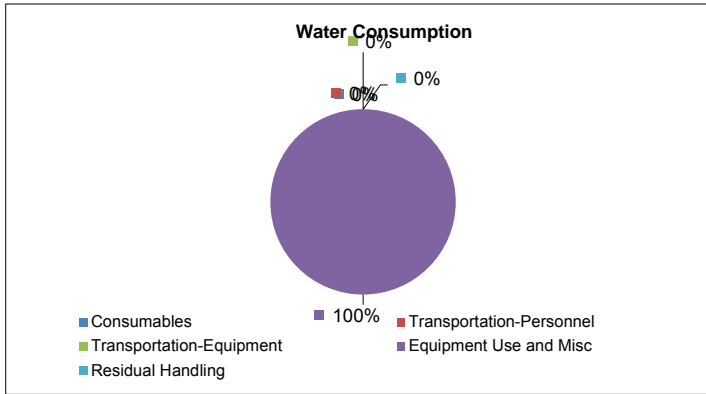
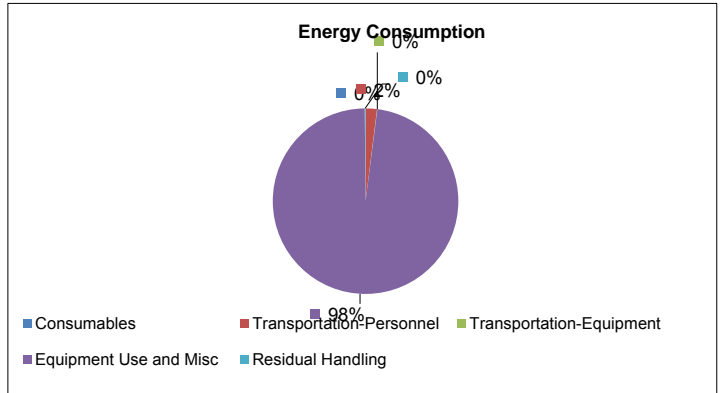
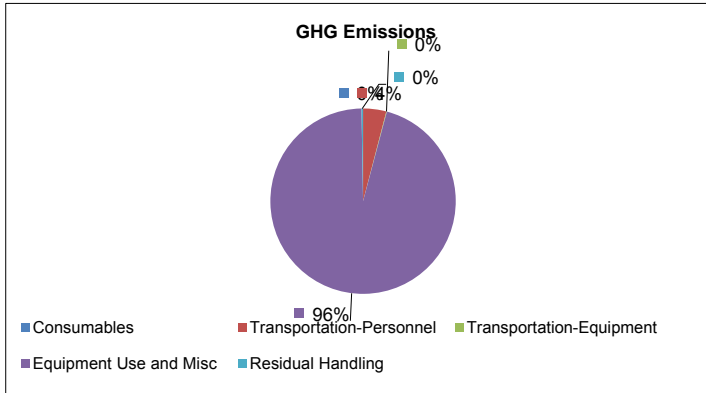

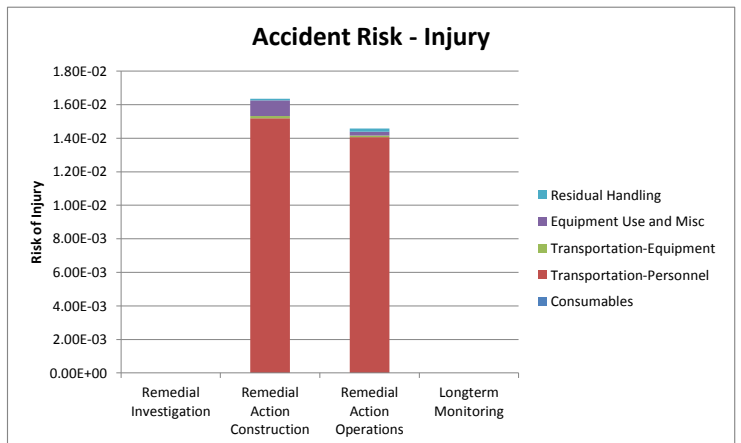
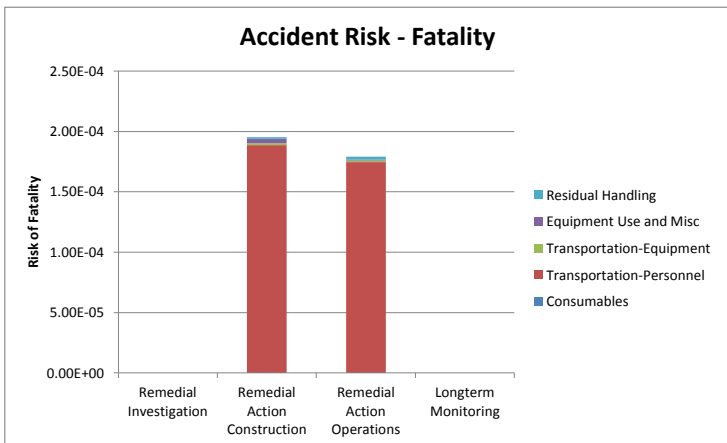
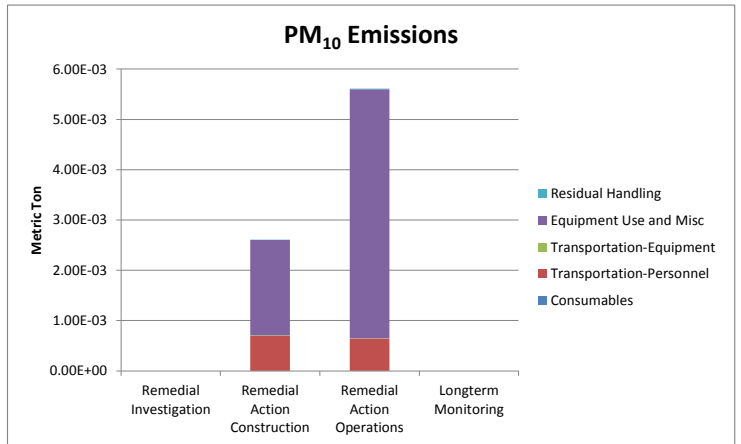
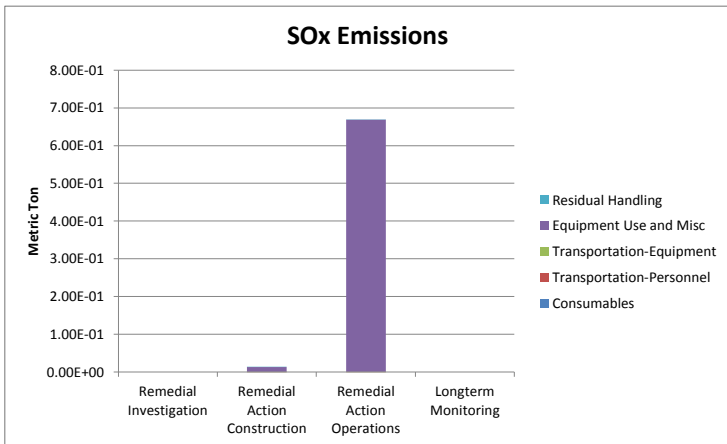
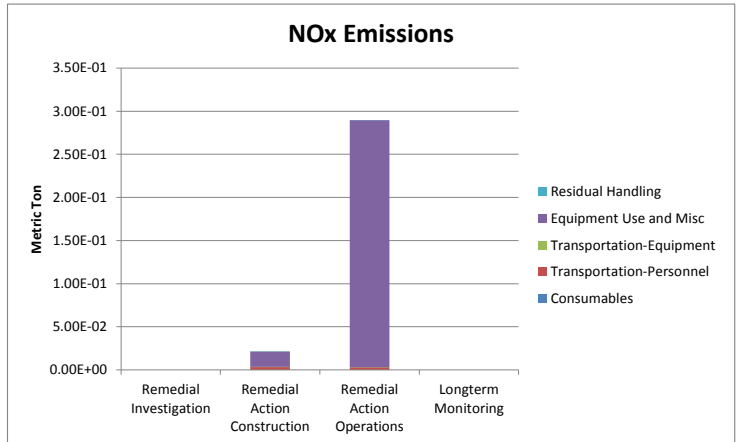
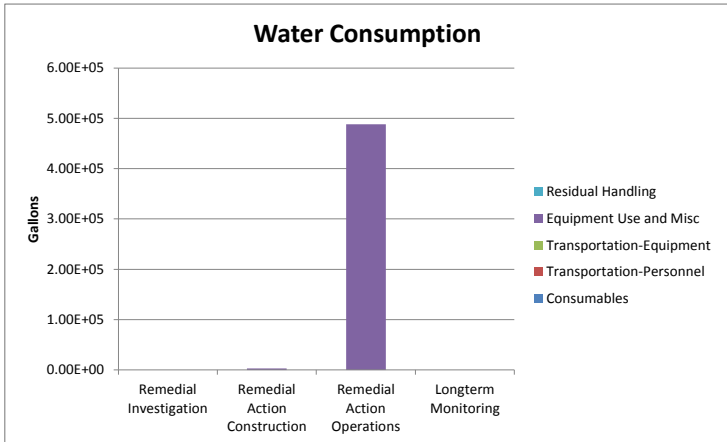
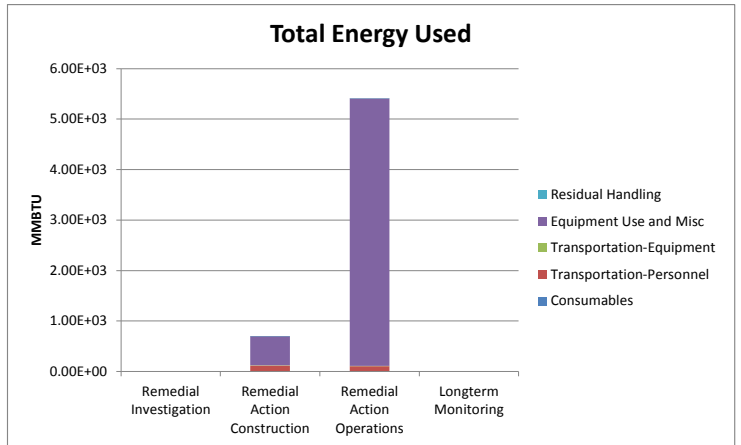
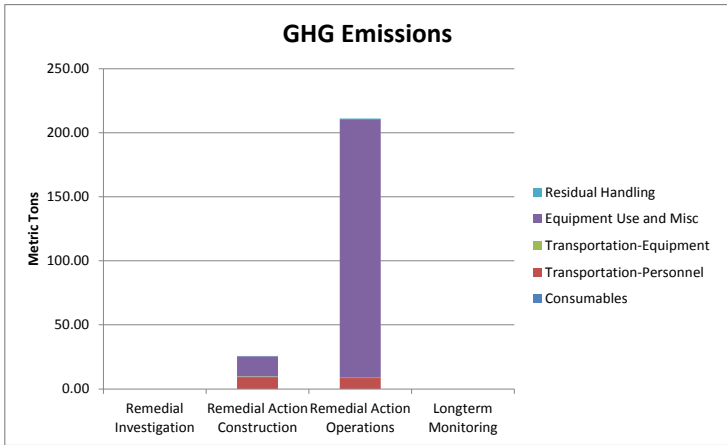

Stage	Technology Module / Phase	Module Components	Comments / Assumptions	Quantity	(Units)	Greenhouse Gas Emissions				Criteria Pollutant Emission			Energy Consumption	Water Consumption
						CO ₂ e	CO ₂	N ₂ O	CH ₄	NO _x	SO _x	PM ₁₀		
						Tonnes				MWhr	gal x 1000			
RAC	Air Injection Wells (1 inch diameter) 14 at 70 ft	Steel	1 inch carbon steel pipe, 14 wells at 70 ft , 1.68 lbs/ft	980.00	lft	2.10	2.02	0.00	0.00	0.00	0.00	0.00	34.73	0.88
RAC	Air Injection Wells (1 inch diameter) 100 ft	Steel	1 inch carbon steel pipe, 100 ft , 1.68 lbs/ft	100.00	lft	0.21	0.21	0.00	0.00	0.00	0.00	0.00	3.54	0.09
RAC	1" Injection Wells (14 Clusters - 12 at 50 and 60, 4 at 70 feet)	Steel	1 inch carbon steel pipe, 300 LF, 1.68 lbs/ft	300.00	lft	0.64	0.62	0.00	0.00	0.00	0.00	0.00	10.63	0.27
RAC	Steam Injection Piping (1 inch steel - underground)	Steel	1 inch carbon steel pipe, 180 LF, 1.68 lbs/ft	180.00	lft	0.39	0.37	0.00	0.00	0.00	0.00	0.00	6.38	0.16
RAC	6" Product Recovery Wells (1 at 60 feet)	Steel	6 inch carbon steel pipe, 60 LF, 18.97 lbs/ft	60.00	lft	1.45	1.39	0.00	0.00	0.00	0.00	0.00	24.01	0.05
RAC	Product Recovery Piping	Steel	2 inch carbon steel pipe, 80 LF, 3.65 lbs/ft	80.00	lft	0.37	0.36	0.00	0.00	0.00	0.00	0.00	6.16	0.07
RAC	Building & Footing (Concrete)	General Concrete	assume block building with foundation, 600 ft2, Consider only concrete, weight of 0.5 ft of poured concrete 145 lb/ft2, 41 bags of cement	45,960.00	lbs	2.71	2.71	0.00	0.00	0.00	0.00	0.00	26.75	0.00
RAC	Building & Footing	General Concrete	Assume 12 ft high walls at 100 LF. 1350 blocks (40 lb/ea),	54,000.00	lbs	3.18	3.18	0.00	0.00	0.00	0.00	0.00	31.42	0.00
RAC	Building & Footing	Sand	4.72 tons of sand	9,440.00	lbs	0.02	0.02	0.00	0.00	0.00	0.00	0.00	0.58	0.00
RAC	Temporary Equipment Decon Pad Frame	Wood	Assume wood, 4x4 in, (30ftx40ft pad) 140 ft of timber, density for pine 530 kg/m3	514.68	lbs	0.01	0.01	0.00	0.00	0.00	0.00	0.00	0.01	0.00
RAC	Temporary Equipment Decon Pad Liner	HDPE	assume HDPE, Assume 30ftx40ft, 3 mm thick, 0.95 g/cm3	700.47	lbs	1.56	0.83	0.00	0.01	0.00	0.00	0.00	9.17	0.25
RAO	GAC (Liquid & Vapor)	Regenerated GAC	5000 lbs/year, 2 years operation, assume reactivated GAC	10,000.00	lbs	8.57	8.57	0.00	0.00	0.00	0.00	0.00	85.76	0.00
Subtotal						21.22	20.28	0.00	0.01	0.00	0.01	0.00	239.14	1.78
Construction Equipment						Tonnes				MWhr	gal x 1000			
RAC	Excavator (building construction), 2.5 CY (diesel)	Excavator, Hydraulic, 2 CY (diesel)	excavate 600 ft2, 1 ft deep, 600 ft3/27cy= 22.2 cy, Assume 10 cy/day, 8 hrs/day, 80% utility	14.21	hrs	1.38	1.38	0.00	0.00	0.01	0.00	0.00	6.25	
RAC	DPT Drill Rig (Air, Steam, Recovery wells)	Drill Rig, DPT (diesel)	21 wells, 5 wells/day, 8 hrs, 80% utility	26.88	hrs	0.43	0.42	0.00	0.00	0.00	0.00	0.00	3.29	
RAO	Drilling/Split Spoon to 70 ft (4 borings)	Drill Rig, DPT (diesel)	4 soil samples. 5 samples per day. 2 events. 8 hour/day, 80 % utility	10.24	hrs	0.16	0.16	0.00	0.00	0.00	0.00	0.00	1.25	
Subtotal						1.97	1.96	0.00	0.00	0.01	0.00	0.00	10.79	0
Total						23	22	0.00	0.01	0.02	0.01	0.00	250	2



Alternative 1
 Values Input into SiteWise as "Other"

Module	Greenhouse Gas Emissions				Criteria Pollutant Emission			Energy Consumption	Water Consumption		
	CO ₂ e	CO ₂	N ₂ O (CO ₂ e)	CH ₄ (CO ₂ e)	NO _x	SO _x	PM ₁₀				
						Tonnes				MMBTU	gal
RI	-	-	-	-	-	-	-	-	-	-	-
RAC	14.45	13.50	0.78	0.17	0.01	0.01	0.00	555.87	1,783.02		
RAO	8.74	8.73	-	0.00	0.00	0.00	0.00	296.87	-		
LTM	-	-	-	-	-	-	-	-	-		

Note: 1 MWhr = 3412141.4799 BTU, 1MMTBU = 10⁶ BTU

**Sustainable Remediation - Environmental Footprint Summary
 Alternative 5**

Phase	Activities	GHG Emissions	Total energy Used	Water Consumption	NOx emissions	SOx Emissions	PM10 Emissions	Accident Risk Fatality	Accident Risk Injury
		metric ton	MMBTU	gallons	metric ton	metric ton	metric ton		
Remedial Investigation	Consumables	0.00	0.0E+00	NA	NA	NA	NA	NA	NA
	Transportation-Personnel	0.00	0.0E+00	NA	0.0E+00	0.0E+00	0.0E+00	0.0E+00	0.0E+00
	Transportation-Equipment	0.00	0.0E+00	NA	0.0E+00	0.0E+00	0.0E+00	0.0E+00	0.0E+00
	Equipment Use and Misc	0.00	0.0E+00	0.0E+00	0.0E+00	0.0E+00	0.0E+00	0.0E+00	0.0E+00
	Residual Handling	0.00	0.0E+00	NA	0.0E+00	0.0E+00	0.0E+00	0.0E+00	0.0E+00
	Sub-Total	0.00	0.00E+00	0.00E+00	0.00E+00	0.00E+00	0.00E+00	0.00E+00	0.00E+00
Remedial Action Construction	Consumables	0.00	0.0E+00	NA	NA	NA	NA	NA	NA
	Transportation-Personnel	9.22	1.2E+02	NA	3.4E-03	1.2E-04	6.9E-04	1.9E-04	1.5E-02
	Transportation-Equipment	0.81	1.1E+01	NA	2.6E-04	8.3E-06	2.2E-05	2.0E-06	1.6E-04
	Equipment Use and Misc	44.47	3.9E+03	8.3E+04	2.4E-02	4.8E-02	3.6E-03	7.0E-06	1.8E-03
	Residual Handling	0.15	2.0E+00	NA	4.7E-05	1.9E-06	3.8E-06	7.8E-07	6.3E-05
	Sub-Total	54.65	4.01E+03	8.32E+04	2.74E-02	4.84E-02	4.30E-03	1.99E-04	1.72E-02
Remedial Action Operations	Consumables	0.00	0.0E+00	NA	NA	NA	NA	NA	NA
	Transportation-Personnel	12.35	1.6E+02	NA	4.6E-03	1.6E-04	9.3E-04	2.5E-04	2.0E-02
	Transportation-Equipment	1.79	2.5E+01	NA	5.8E-04	2.4E-05	4.7E-05	5.0E-06	4.0E-04
	Equipment Use and Misc	219.34	1.8E+04	4.8E+05	1.3E-01	4.1E-01	1.8E-03	9.4E-07	2.4E-04
	Residual Handling	5.99	8.2E+01	NA	1.9E-03	7.9E-05	1.6E-04	1.5E-05	1.2E-03
	Sub-Total	239.47	1.79E+04	4.78E+05	1.37E-01	4.09E-01	2.90E-03	2.74E-04	2.22E-02
Longterm Monitoring	Consumables	0.00	0.0E+00	NA	NA	NA	NA	NA	NA
	Transportation-Personnel	0.00	0.0E+00	NA	0.0E+00	0.0E+00	0.0E+00	0.0E+00	0.0E+00
	Transportation-Equipment	0.00	0.0E+00	NA	0.0E+00	0.0E+00	0.0E+00	0.0E+00	0.0E+00
	Equipment Use and Misc	0.00	0.0E+00	0.0E+00	0.0E+00	0.0E+00	0.0E+00	0.0E+00	0.0E+00
	Residual Handling	0.00	0.0E+00	NA	0.0E+00	0.0E+00	0.0E+00	0.0E+00	0.0E+00
	Sub-Total	0.00	0.00E+00	0.00E+00	0.00E+00	0.00E+00	0.00E+00	0.00E+00	0.00E+00
Total		2.9E+02	2.2E+04	5.6E+05	1.6E-01	4.6E-01	7.2E-03	4.7E-04	3.9E-02

Remedial Alternative Phase	Non-Hazardous Waste Landfill Space	Hazardous Waste Landfill Space	Topsoil Consumption	Costing	Lost Hours - Injury
	tons	tons	cubic yards	\$	
Remedial Investigation	0.0E+00	0.0E+00	0.0E+00	0	0.0E+00
Remedial Action Construction	0.0E+00	0.0E+00	0.0E+00	0	1.4E-01
Remedial Action Operations	0.0E+00	0.0E+00	0.0E+00	0	1.8E-01
Longterm Monitoring	0.0E+00	0.0E+00	0.0E+00	0	0.0E+00
Total	0.0E+00	0.0E+00	0.0E+00	\$0	3.2E-01

Total Cost with Footprint Reduction
\$0

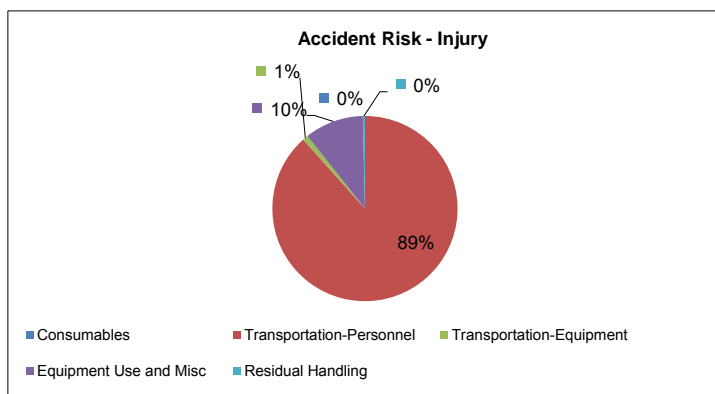
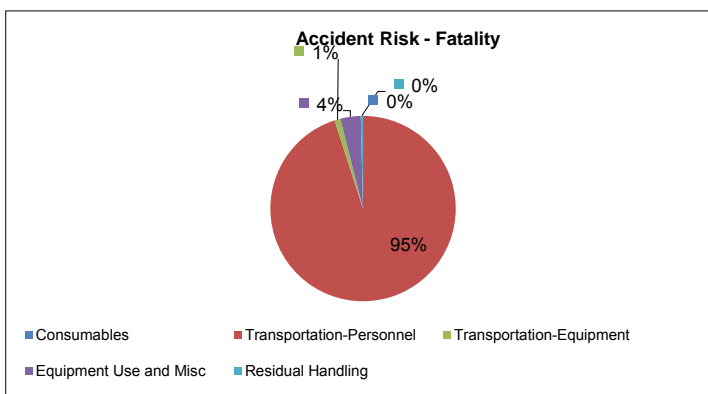
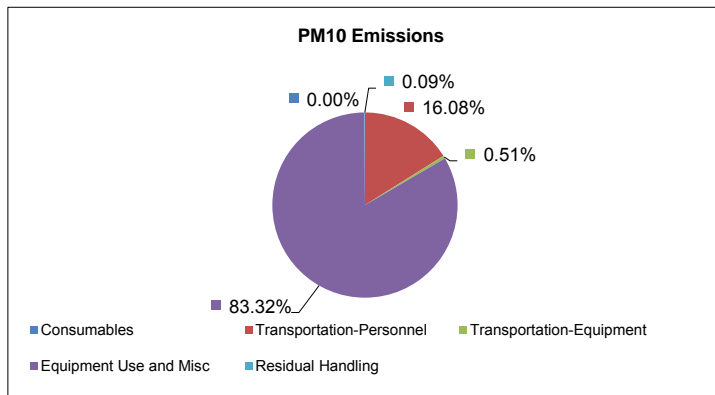
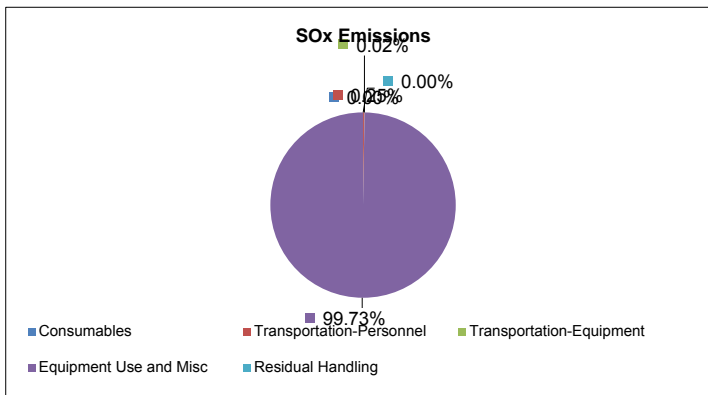
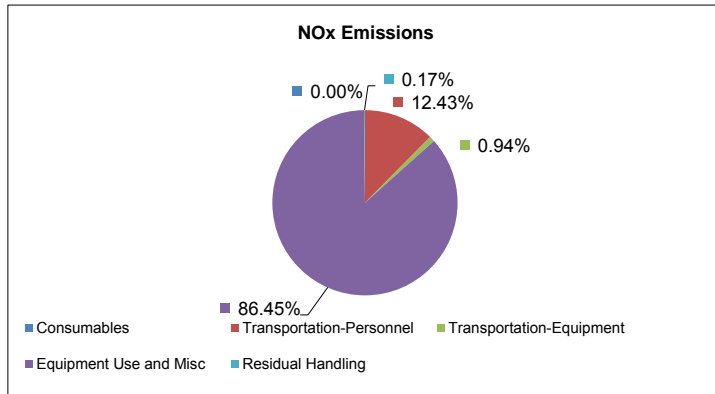
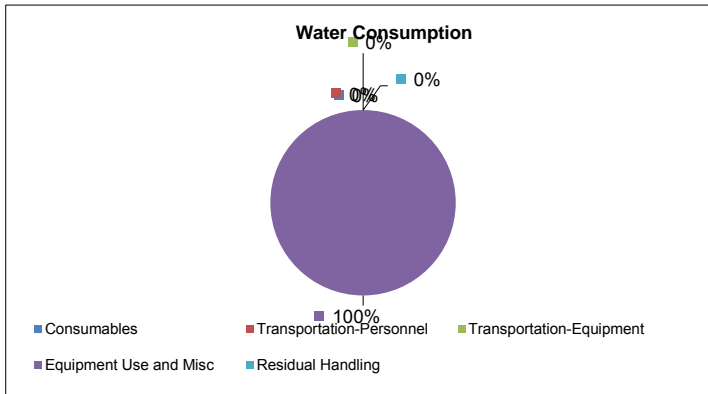
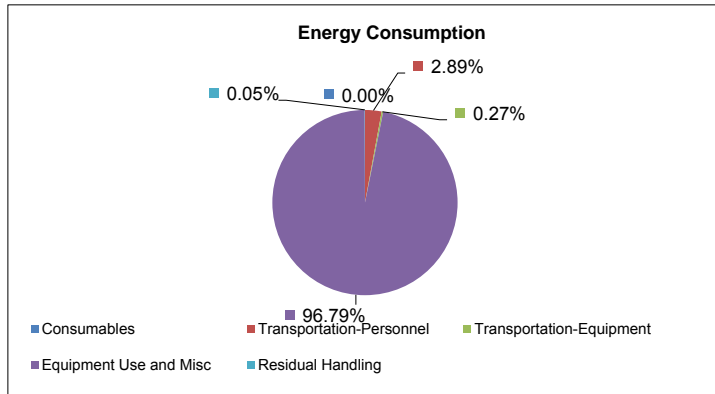
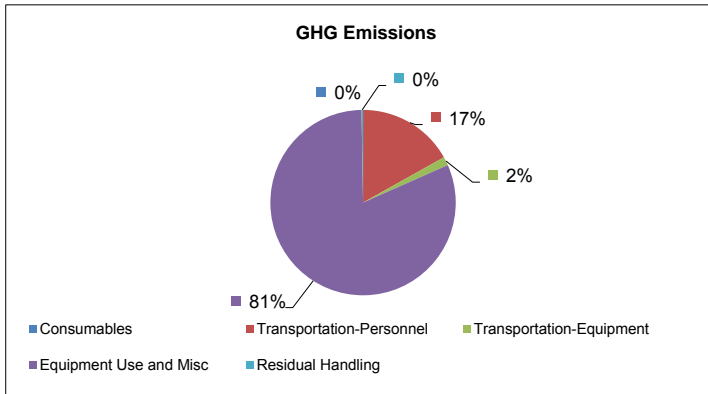

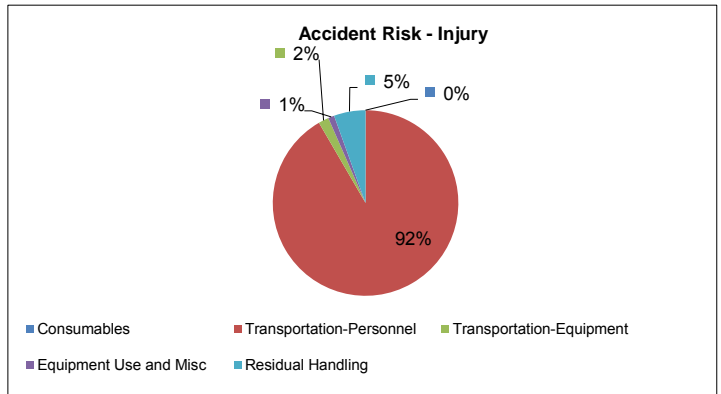
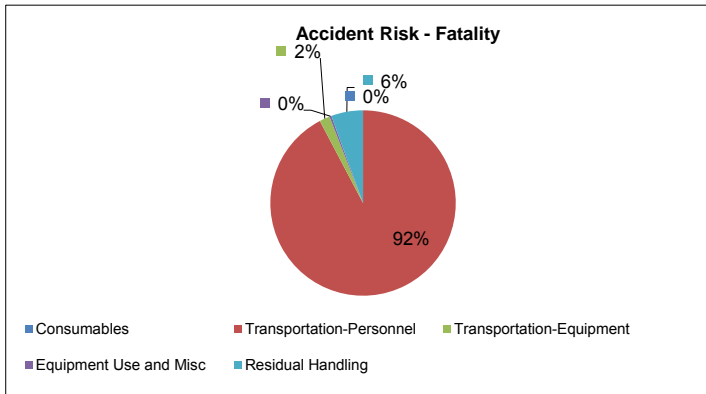
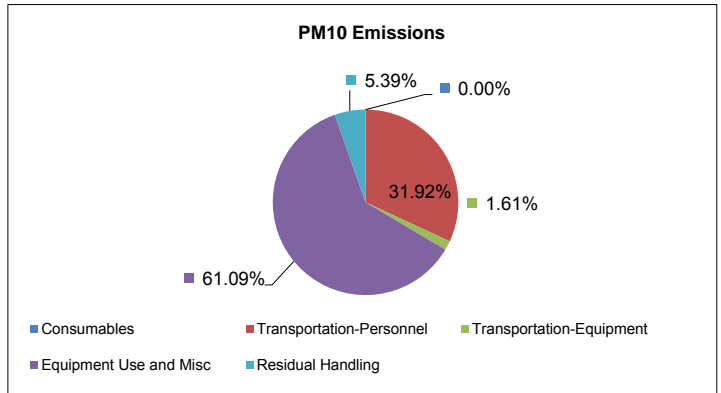
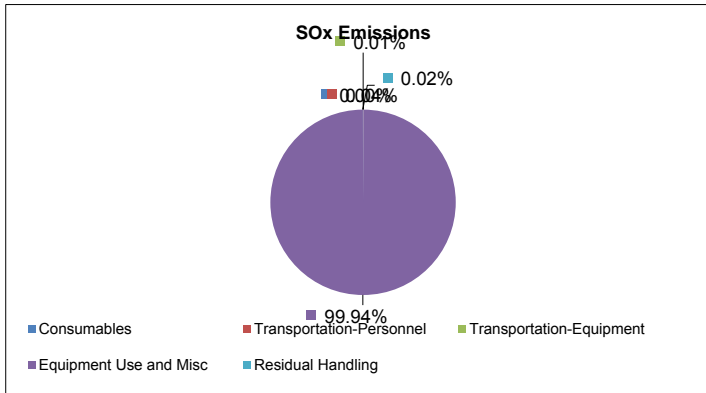
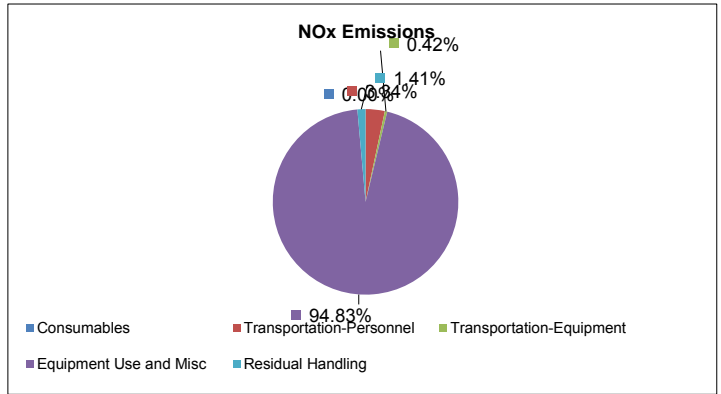
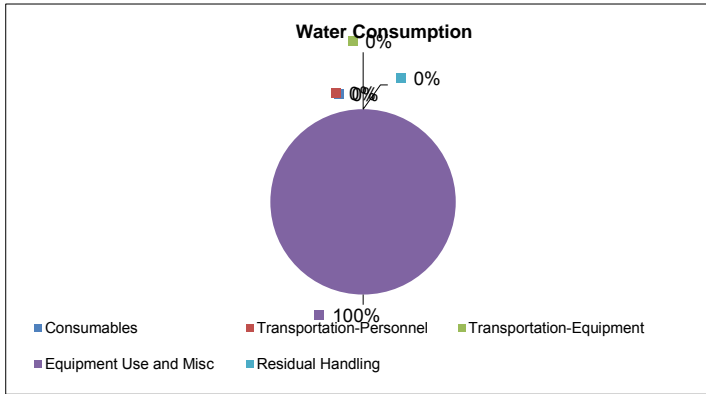
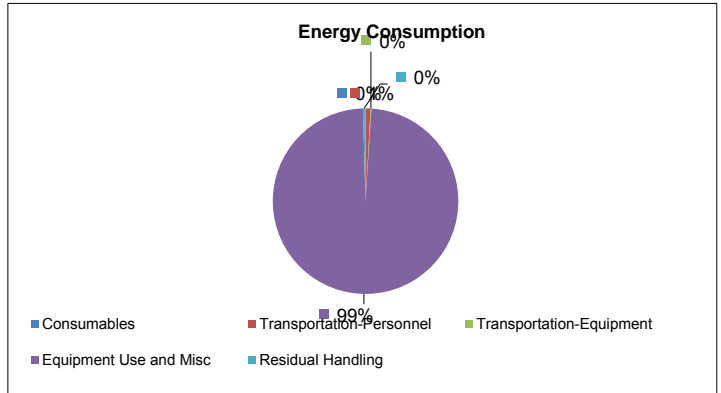
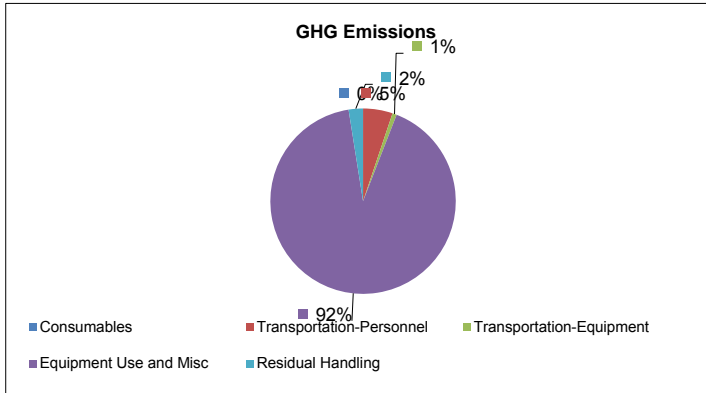

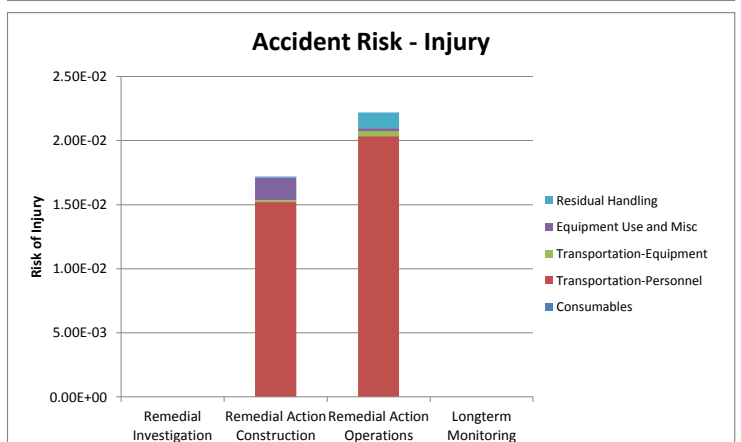
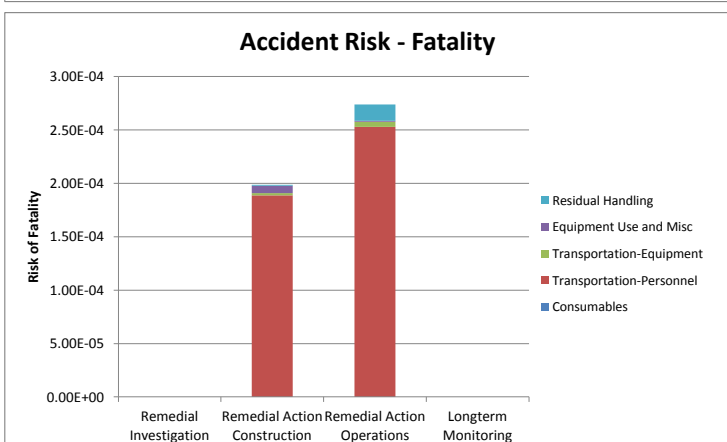
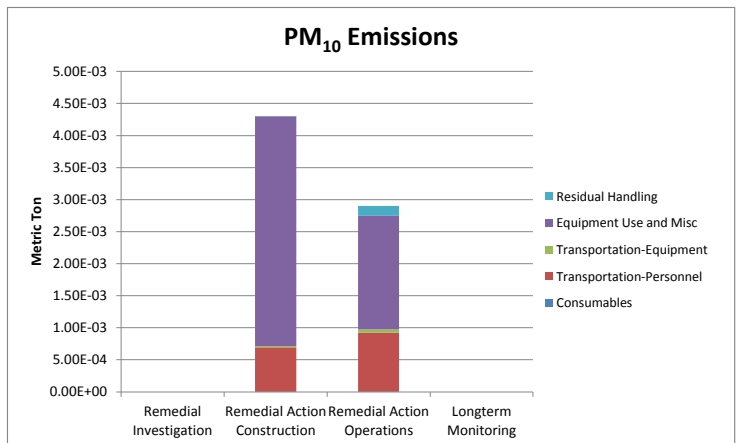
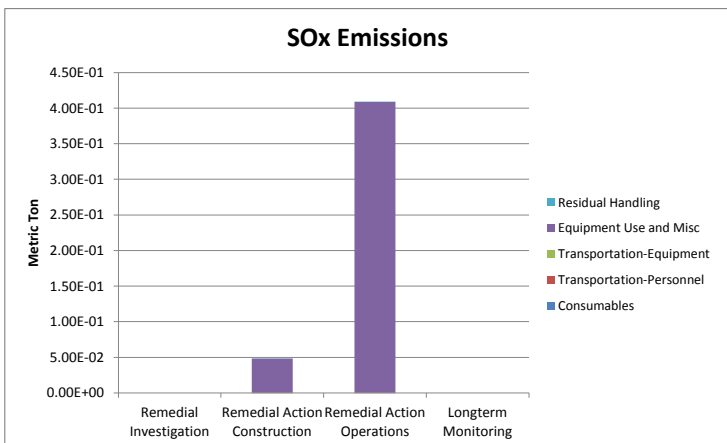
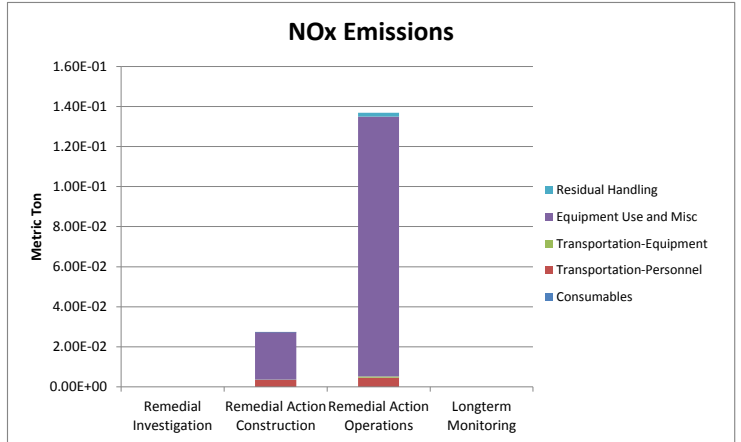
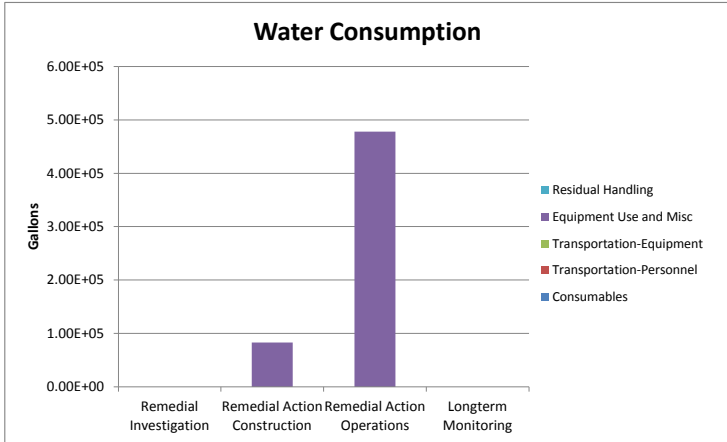
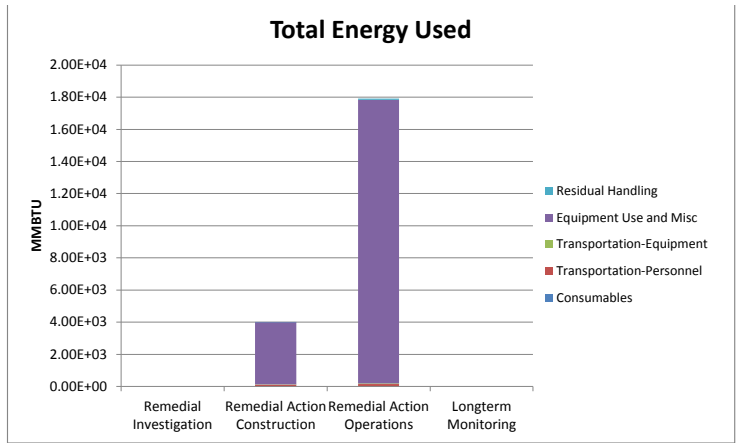
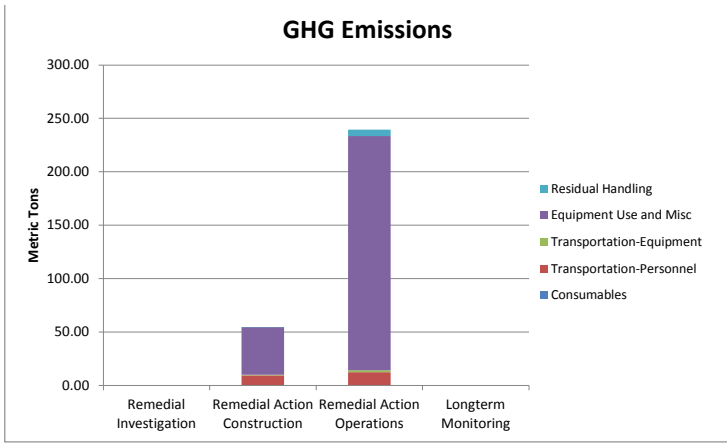

Stage	Technology Module / Phase	Module Components	Comments / Assumptions	Quantity	(Units)	Greenhouse Gas Emissions				Criteria Pollutant Emission			Energy Consumption	Water Consumption
						CO ₂ e	CO ₂	N ₂ O	CH ₄	NO _x	SO _x	PM ₁₀		
						Tonnes				MWhr	gal x 1000			
RAC	Solvent Injection Wells (12 at 70 ft and 32 at 20 ft)	PVC	Assume 2 inch schedule 40 PVC pipe, 1480 LF, 0.72 lbs/ft	1,480.00	lft	2.40	1.21	0.00	0.01	0.00	0.00	0.00	44.06	2.54
RAC	Solvent Injection Piping	PVC	Assume 2 inch schedule 40 PVC pipe, 700 LF, 0.72 lbs/ft	700.47	lft	1.14	0.57	0.00	0.01	0.00	0.00	0.00	20.85	1.20
RAC	6" Product Recovery Wells (5 at 60 feet)	Steel	6 inch carbon steel pipe, 300 LF, 18.97 lbs/ft	300.00	lft	7.25	6.97	0.00	0.00	0.00	0.01	0.00	120.06	0.27
RAC	Product Piping	PVC	Assume 2 inch schedule 40 PVC pipe, 180 LF, 0.72 lbs/ft	180.00	lft	0.29	0.15	0.00	0.00	0.00	0.00	0.00	5.36	0.31
RAC	Temporary Equipment Decon Pad Liner	HDPE	assume HDPE, Assume 30ftx40ft, 3 mm thick, 0.95 g/cm3	700.00	lbs	1.56	0.83	0.00	0.01	0.00	0.00	0.00	9.16	0.25
RAC	Temporary Equipment Decon Pad Frame	Wood	Assume wood, 4x4 in, (30ftx40ft pad) 140 ft of timber, density for pine 530 kg/m3	514.68	lbs	0.01	0.01	0.00	0.00	0.00	0.00	0.00	0.01	0.00
RAC	Building & Footing (Concrete)	General Concrete	assume block building with foundation, 160ft2, Consider only concrete, weight of 0.5 ft of poured concrete 145 lb/ft2, 21 bags of cement	12,860.00	lbs	0.76	0.76	0.00	0.00	0.00	0.00	0.00	7.48	0.00
RAC	Building & Footing	General Concrete	Assume 12 ft high walls at 52 LF. 702 blocks (40 lb/ea),	28,080.00	lbs	1.66	1.66	0.00	0.00	0.00	0.00	0.00	16.34	0.00
RAC	Building & Footing	Sand	2.46 tons of sand	4,920.00	lbs	0.01	0.01	0.00	0.00	0.00	0.00	0.00	0.30	0.00
RAC	Solvent (Vertec)	Vegetable Oil	20,000 gallons of Vertec, SG of 1.03, Vertec EL is technical grade ethyl lactate, carbon neutral formula.	171,804.00	lbs	25.71	25.71	0.00	0.00	0.00	0.03	0.00	894.53	77.61
RAO	Solvent (Vertec)	Vegetable Oil	50,000 gallons of Vertec/year, SG of 1.03, Vertec EL is technical grade ethyl lactate, carbon neutral formula.	859,020.00	lbs	128.56	128.56	0.00	0.00	0.00	0.13	0.00	4472.63	388.03
RAO	GAC (Liquid & Vapor)	Regenerated GAC	5000 lbs/year, 2 years operation, assume reactivated GAC	10,000.00	lbs	8.57	8.57	0.00	0.00	0.00	0.00	0.00	85.76	0.00
Subtotal						177.92	175.00	0.01	0.03	3.78E-04	0.17	0.00	5676.53	470.22
Construction Equipment						Tonnes				MWhr	gal x 1000			
RAC	Excavator (building construction), 2.5 CY (diesel)	Excavator, Hydraulic, 2 CY (diesel)	excavate 600 ft2, 1 ft deep, 600 ft3/27cy= 22.2 cy, Assume 10 cy/day, 8 hrs/day, 80% utility	14.21	hrs	1.38	1.38	0.00	0.00	0.01	0.00	0.00	6.25	
RAC	DPT Drill Rig (solvent injection wells)	Drill Rig, DPT (diesel)	44 solvent injection wells, 5 wells/day, 8 hrs, 80% utility	56.32	hrs	0.90	0.88	0.00	0.00	0.01	0.00	0.00	6.88	
RAC	DPT Drill Rig (solvent extraction wells)	Drill Rig, DPT (diesel)	5 solvent injection wells, 5 wells/day, 8 hrs, 80% utility	6.40	hrs	0.10	0.10	0.00	0.00	0.00	0.00	0.00	0.78	
RAO	Drilling/Split Spoon to 70 ft (4 borings)	Drill Rig, DPT (diesel)	4 soil samples. 5 samples per day. 2 events. 8 hour/day, 80 % utility	10.24	hrs	0.16	0.16	0.00	0.00	0.00	0.00	0.00	1.25	
Subtotal						2.55	2.52	0.00	0.00	0.02	0.00	0.00	15.17	0
Total						180	178	0.01	0.03	0.02	0.17	0.00	5,692	470



Alternative 1
 Values Input into SiteWise as "Other"

Module	Greenhouse Gas Emissions				Criteria Pollutant Emission			Energy Consumption	Water Consumption
	CO ₂ e	CO ₂	N ₂ O (CO ₂ e)	CH ₄ (CO ₂ e)	NO _x	SO _x	PM ₁₀		
					Tonnes			MMBTU	gal
RI	-	-	-	-	-	-	-	-	-
RAC	43.17	40.22	2.28	0.66	0.02	0.05	0.00	3,862.60	82,190.22
RAO	137.30	137.29	0.00	0.00	0.00	0.13	0.00	15,557.49	388,034.33
LTM	-	-	-	-	-	-	-	-	-

Note: 1 MWhr = 3412141.4799 BTU, 1MMBTU = 10⁶ BTU

**Sustainable Remediation - Environmental Footprint Summary
 Alternative 6A**

Phase	Activities	GHG Emissions	Total energy Used	Water Consumption	NOx emissions	SOx Emissions	PM10 Emissions	Accident Risk Fatality	Accident Risk Injury
		metric ton	MMBTU	gallons	metric ton	metric ton	metric ton		
Remedial Investigation	Consumables	0.00	0.0E+00	NA	NA	NA	NA	NA	NA
	Transportation-Personnel	0.00	0.0E+00	NA	0.0E+00	0.0E+00	0.0E+00	0.0E+00	0.0E+00
	Transportation-Equipment	0.00	0.0E+00	NA	0.0E+00	0.0E+00	0.0E+00	0.0E+00	0.0E+00
	Equipment Use and Misc	0.00	0.0E+00	0.0E+00	0.0E+00	0.0E+00	0.0E+00	0.0E+00	0.0E+00
	Residual Handling	0.00	0.0E+00	NA	0.0E+00	0.0E+00	0.0E+00	0.0E+00	0.0E+00
	Sub-Total	0.00	0.00E+00	0.00E+00	0.00E+00	0.00E+00	0.00E+00	0.00E+00	0.00E+00
Remedial Action Construction	Consumables	0.00	0.0E+00	NA	NA	NA	NA	NA	NA
	Transportation-Personnel	34.01	4.3E+02	NA	1.3E-02	4.4E-04	2.6E-03	7.0E-04	5.6E-02
	Transportation-Equipment	33.97	4.6E+02	NA	1.1E-02	4.4E-04	8.9E-04	8.6E-05	6.9E-03
	Equipment Use and Misc	374.31	2.4E+04	8.4E+03	4.3E-01	2.0E-01	1.4E+00	9.7E-05	2.4E-02
	Residual Handling	129.95	1.7E+03	NA	4.1E-02	7.2E-04	3.6E-03	3.2E-04	2.6E-02
	Sub-Total	572.24	2.64E+04	8.38E+03	4.98E-01	2.04E-01	1.39E+00	1.20E-03	1.13E-01
Remedial Action Operations	Consumables	0.00	0.0E+00	NA	NA	NA	NA	NA	NA
	Transportation-Personnel	1.52	1.9E+01	NA	5.6E-04	2.0E-05	1.1E-04	3.1E-05	2.5E-03
	Transportation-Equipment	0.00	0.0E+00	NA	0.0E+00	0.0E+00	0.0E+00	0.0E+00	0.0E+00
	Equipment Use and Misc	12.97	1.9E+02	0.0E+00	4.5E-02	3.0E-02	1.1E-03	0.0E+00	0.0E+00
	Residual Handling	0.00	0.0E+00	NA	0.0E+00	0.0E+00	0.0E+00	0.0E+00	0.0E+00
	Sub-Total	14.50	2.13E+02	0.00E+00	4.55E-02	3.00E-02	1.25E-03	3.12E-05	2.51E-03
Longterm Monitoring	Consumables	0.00	0.0E+00	NA	NA	NA	NA	NA	NA
	Transportation-Personnel	0.00	0.0E+00	NA	0.0E+00	0.0E+00	0.0E+00	0.0E+00	0.0E+00
	Transportation-Equipment	0.00	0.0E+00	NA	0.0E+00	0.0E+00	0.0E+00	0.0E+00	0.0E+00
	Equipment Use and Misc	0.00	0.0E+00	0.0E+00	0.0E+00	0.0E+00	0.0E+00	0.0E+00	0.0E+00
	Residual Handling	0.00	0.0E+00	NA	0.0E+00	0.0E+00	0.0E+00	0.0E+00	0.0E+00
	Sub-Total	0.00	0.00E+00	0.00E+00	0.00E+00	0.00E+00	0.00E+00	0.00E+00	0.00E+00
Total		5.9E+02	2.7E+04	8.4E+03	5.4E-01	2.3E-01	1.4E+00	1.2E-03	1.2E-01

Remedial Alternative Phase	Non-Hazardous Waste Landfill Space	Hazardous Waste Landfill Space	Topsoil Consumption	Costing	Lost Hours - Injury
	tons	tons	cubic yards	\$	
Remedial Investigation	0.0E+00	0.0E+00	0.0E+00	0	0.0E+00
Remedial Action Construction	0.0E+00	0.0E+00	0.0E+00	0	9.1E-01
Remedial Action Operations	0.0E+00	0.0E+00	0.0E+00	0	2.0E-02
Longterm Monitoring	0.0E+00	0.0E+00	0.0E+00	0	0.0E+00
Total	0.0E+00	0.0E+00	0.0E+00	\$0	9.3E-01

Total Cost with Footprint Reduction
\$0

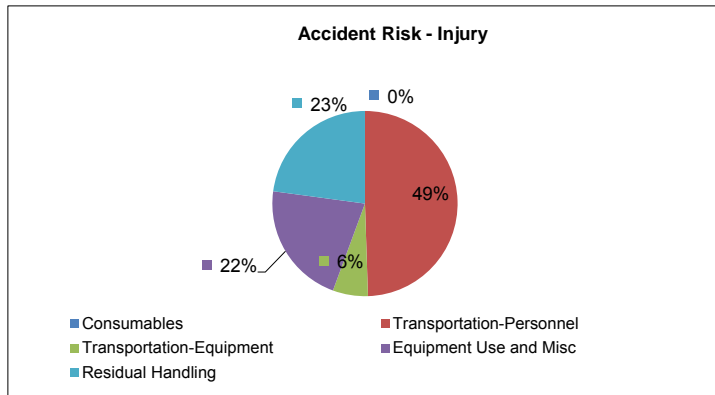
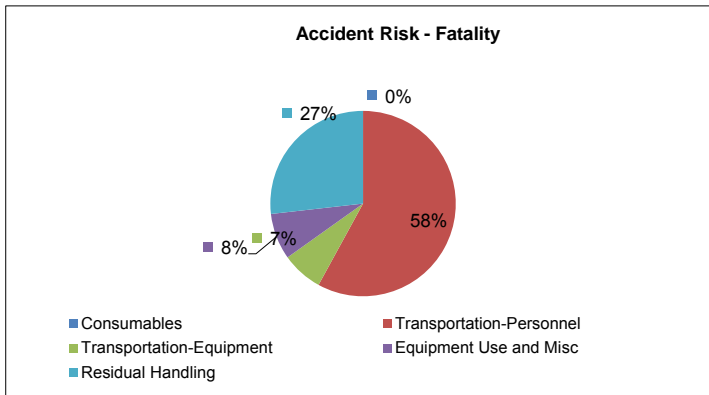
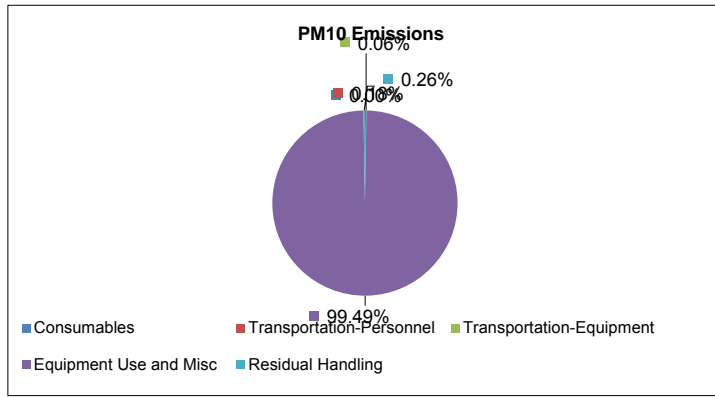
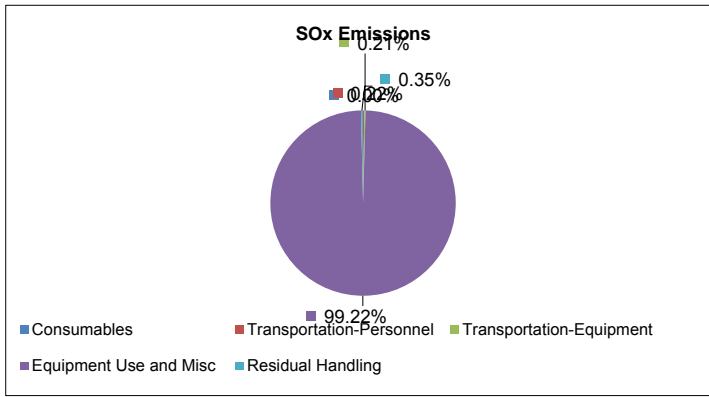
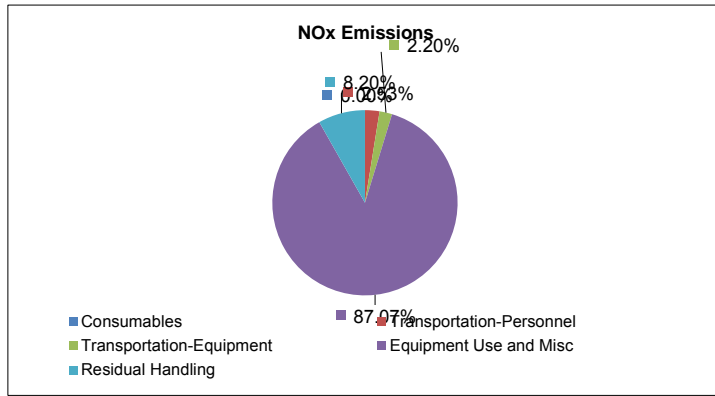
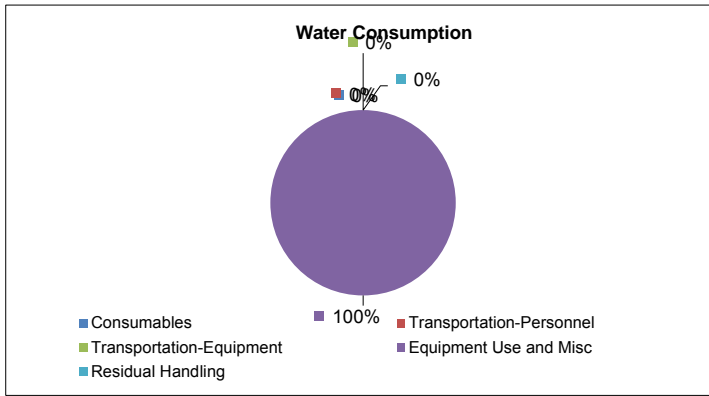
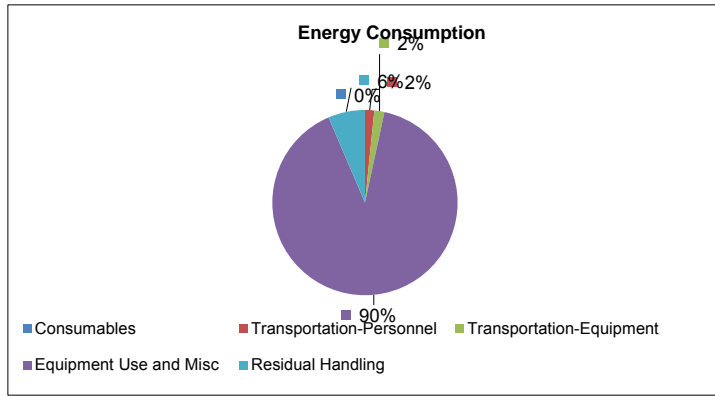
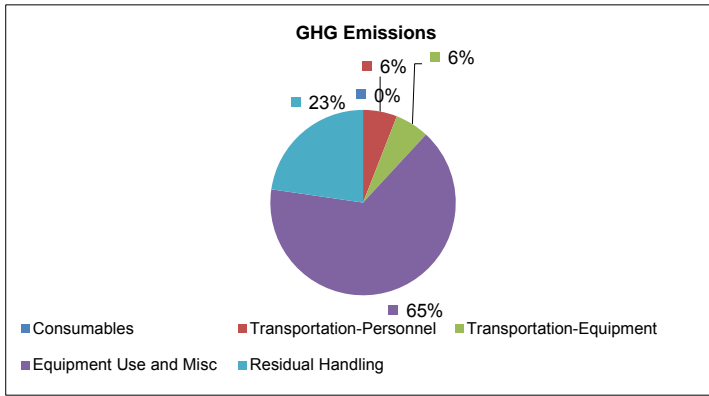

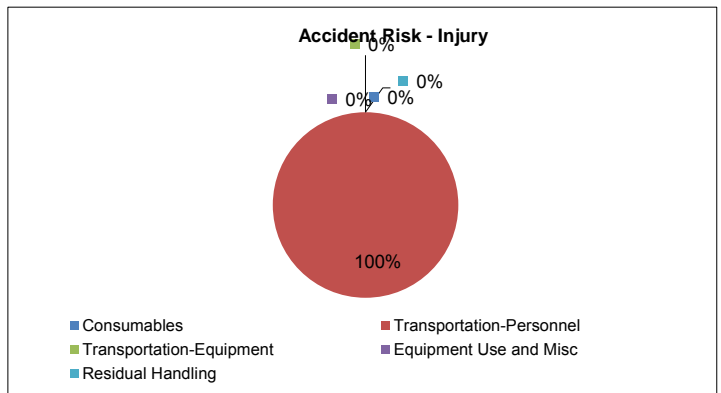
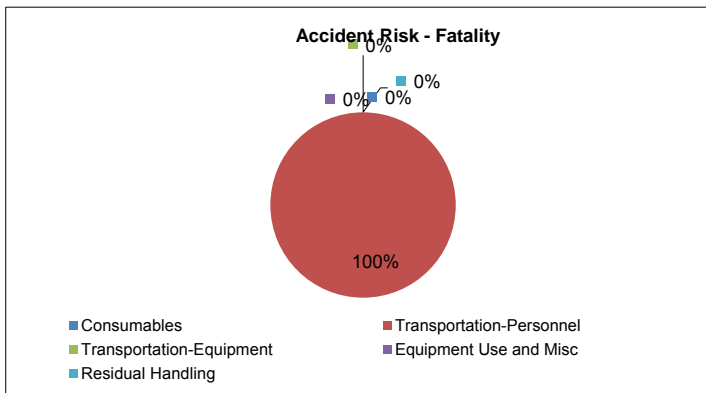
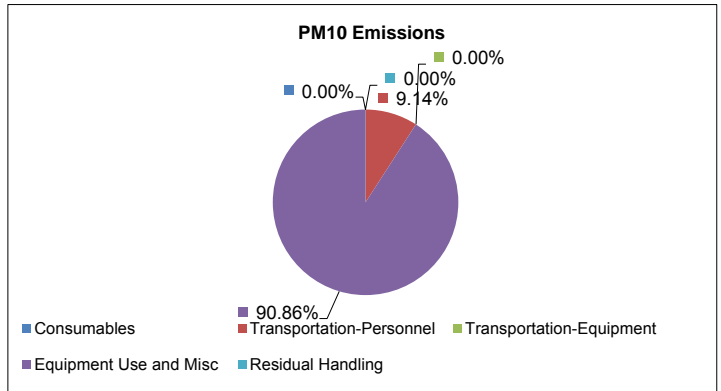
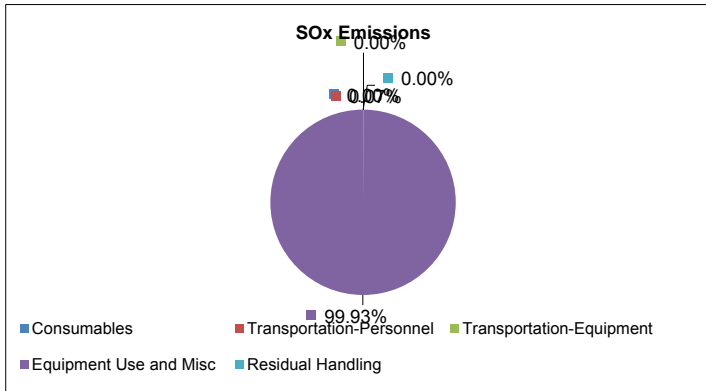
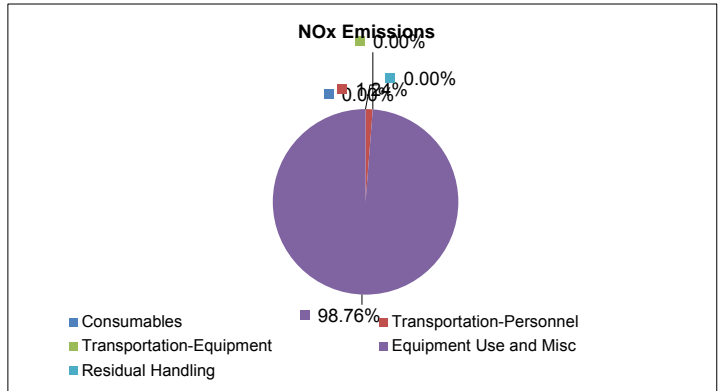
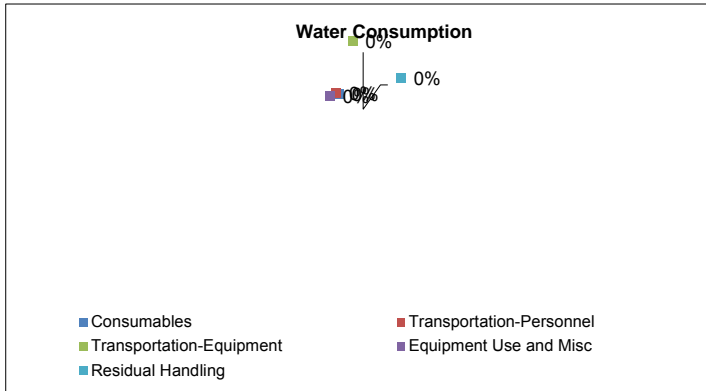
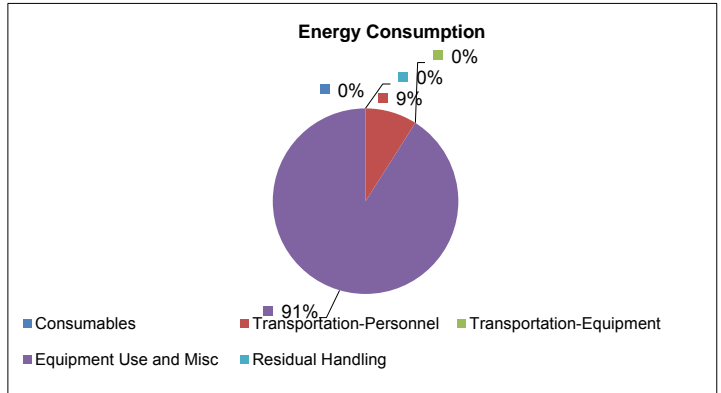
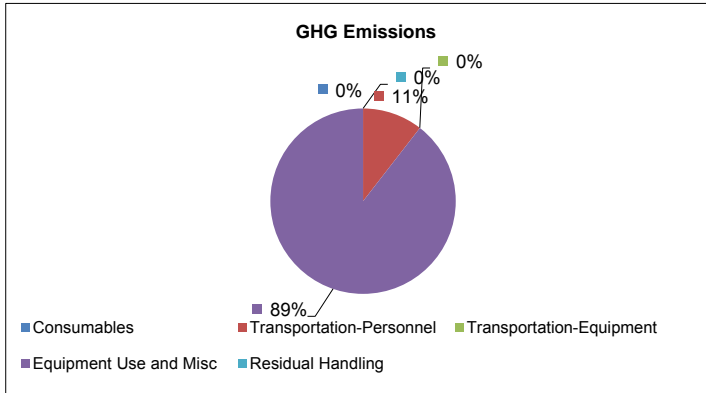

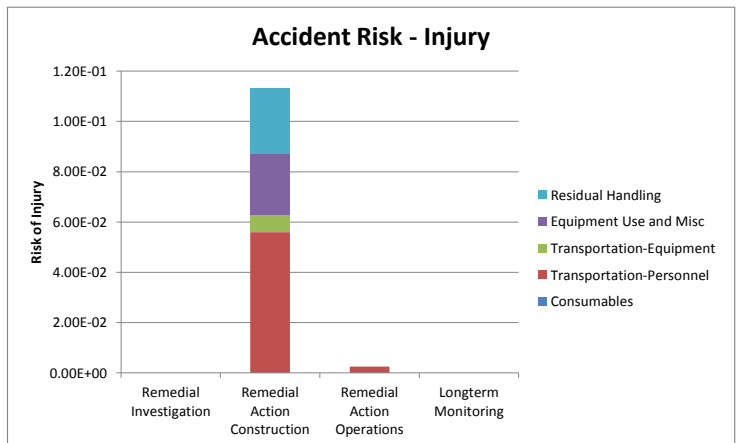
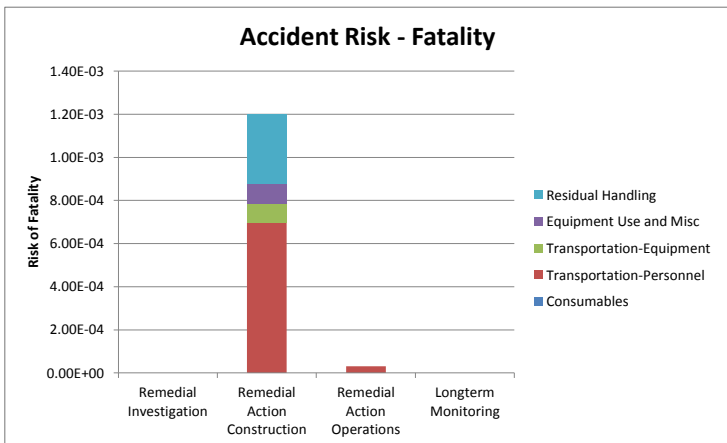
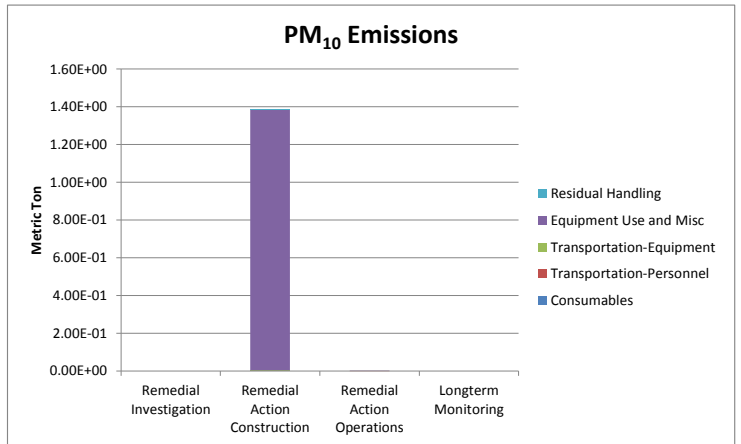
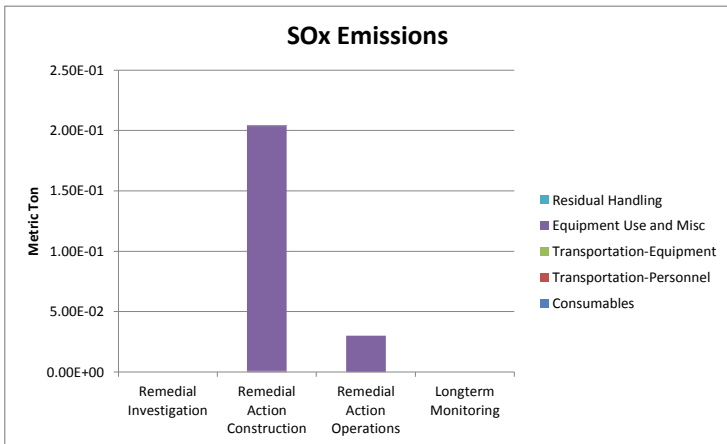
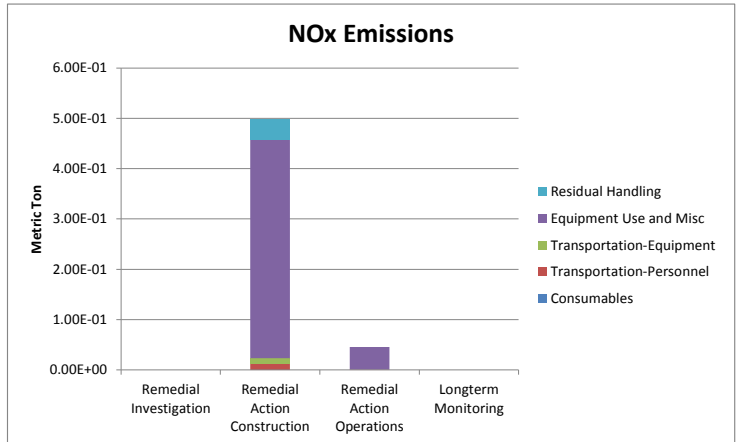
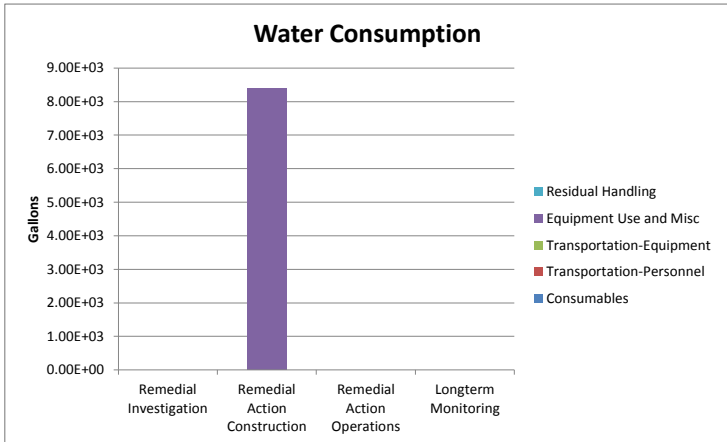
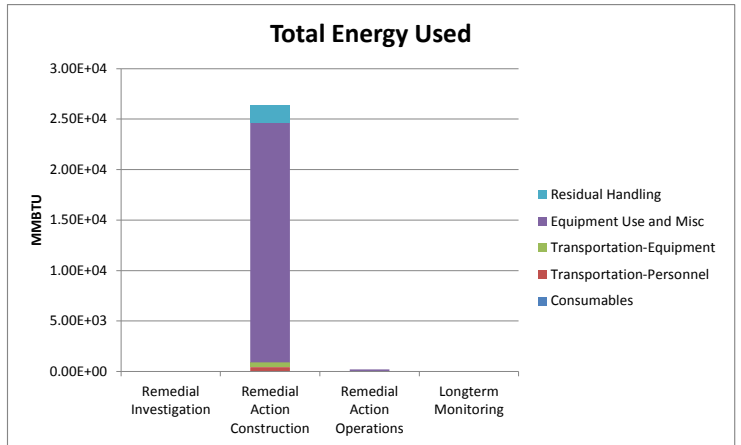
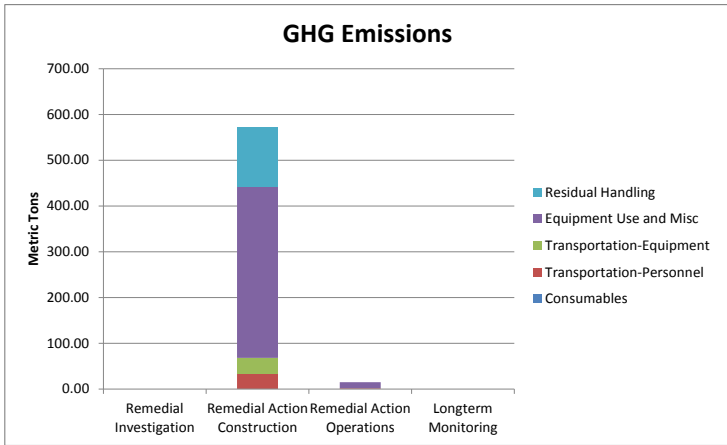

Stage	Technology Module / Phase	Module Components	Comments / Assumptions	Quantity	(Units)	Greenhouse Gas Emissions				Criteria Pollutant Emission			Energy	Water
						CO ₂ e	CO ₂	N ₂ O	CH ₄	NO _x	SO _x	PM ₁₀	Consumptio MWhr	Consumptio gal x 1000
RAC	Monitoring Well Installation	PVC	Pipe Input	160.00	lft	0.26	0.13	0.00	0.00	0.00	0.00	0.00	4.76	0.28
RAC	Temporary Equipment Decon Pad Liner	HDPE	assume HDPE, Assume 30ftx40ft, 3 mm thick, 0.95 g/cm3	700.47	lbs	1.56	0.83	0.00	0.01	0.00	0.00	0.00	9.17	0.25
RAC	Temporary Equipment Decon Pad Frame	Wood	Assume wood, 4x4 in, (30ftx40ft pad) 140 ft of timber, density for pine 530 kg/m3	514.68	lbs	0.01	0.01	0.00	0.00	0.00	0.00	0.00	0.01	0.00
RAC	Construction Entrance	Gravel	Assume 100 yd2 is needed for entrance, Assume 1 ft thick of gravel, 2.5 tons/CY	166,666.67	lbs	1.28	1.28	0.00	0.00	0.00	0.00	0.00	30.63	0.00
RAC	Material staging area (10 ml poly/hay bales 160 ft X 120 ft)	HDPE	Used the following Material handling pad info to develop wieght. HDPE Liner, 5000 sf, 10 oz/sy, 16 oz/lb, 343.75 lbs	7,920.00	lbs	17.68	9.34	0.02	0.07	0.00	0.04	0.01	103.64	2.85
RAC	Backfill (off-site Source)	Soil		21,000,000.00	lbs	219.05	219.05	0.00	0.00	0.00	0.00	0.00	5788.59	0.00
RAC	Top Soil	Soil	60 yd3, Assume 1.5 ton/cy, 2000 lb/ton	180,000.00	lbs	1.88	1.88	0.00	0.00	0.00	0.00	0.00	49.62	0.00
RAC	Repaving (Stone)	Gravel	560 yd2, Assume 6 inches thick, 145 lbs/ft3	365,400.00	lbs	2.82	2.82	0.00	0.00	0.00	0.00	0.00	67.15	0.00
RAC	Repaving (Asphalt)	Asphalt	560 yd2, Assume 3 inches thick, 145lbs/ft3	182,700.00	lbs	1.86	1.53	0.00	0.00	0.00	0.00	1.33	8.29	0.00
RAC	Revegetation seed	Fertilizer	Revegation Seed	10.00	lbs	0.01	0.01	0.00	0.00	0.00	0.00	0.00	0.23	0.00
Subtotal						246.40	236.87	0.03	0.08	0.00	0.04	1.33	6062.07	3.38
Construction Equipment						Tonnes				MWhr			gal x 1000	
RAC	Drilling/Split Spoon	Drill Rig, DPT (diesel)	30 borings, 5 borings /day, 8 hrs, 80% utility	38.40	hrs	0.62	0.60	0.00	0.00	0.01	0.00	0.00	4.69	
RAC	Asphalt Removal (Excavator)	Excavator, Hydraulic, 2 CY (diesel)	560 yd2, Assume 690 yd2/day,	8.00	hrs	0.78	0.78	0.00	0.00	0.00	0.00	0.00	3.52	
RAC	Asphalt Removal (Loader)	Loader, 155 HP, 3 CY (diesel)	561 yd2, Assume 690 yd2/day,	8.00	hrs	0.16	0.16	0.00	0.00	0.00	0.00	0.00	0.68	
RAC	Sheet Piling (Crawler Crane)	Crane, 500 hp, diesel	Use FT2 of sheet piling needed. 360 ft perimter. 71 ft bgs. 25 ft depth installation described in RS Means. Daily Output = 553 ft2/day. Multiply hours by 3 due complexity in driving to 71 bgs	138.66	hrs	13.02	13.02	0.00	0.00	0.00	0.00	0.01	148.39	
RAC	Sheet Piling (Vibrator Hammer & Generator)	Vibratory Hammer, 250 hp	Consider time needed is same as above	138.66	hrs	10.24	10.24	0.00	0.00	0.08	0.00	0.01	67.35	
RAC	Excavation (2.5 CY Excavator)	Excavator, Hydraulic, 2 CY (diesel)	21,000 CY, 765 CY/day, 80 utility	175.69	hrs	17.03	17.03	0.00	0.00	0.11	0.03	0.01	77.29	
RAC	Excavation (Clamshell Crane)	Crane, 500 hp, diesel	21,000 CY, 765 CY/day, 80 utility	175.69	hrs	16.50	16.50	0.00	0.00	0.00	0.00	0.01	188.02	
RAC	Concrete UST Pad Removal and Disposal (2.5 CY Excavator)	Excavator, Hydraulic, 2 CY (diesel)	46 CY, 255 CY/day, 80 utility	1.15	hrs	0.11	0.11	0.00	0.00	0.00	0.00	0.00	0.51	
RAC	Backfill of Soils for Reuse (14,000 Cu Yds)	Excavator, Hydraulic, 2 CY (diesel)	14,000 CY, 765 CY/day, 80 utility	117.12	hrs	11.35	11.35	0.00	0.00	0.07	0.02	0.01	51.53	
RAC	Backfill of Soils for Reuse (14,000 Cu Yds)	Crane, 500 hp, diesel	14,000 CY, 765 CY/day, 80 utility	117.12	hrs	11.00	11.00	0.00	0.00	0.00	0.00	0.00	125.34	
RAC	Backfill (off-site Source)	Excavator, Hydraulic, 2 CY (diesel)	7,000 CY, 765 CY/day, 80 utility	58.56	hrs	5.68	5.68	0.00	0.00	0.04	0.01	0.00	25.76	
RAC	Backfill (off-site Source)	Crane, 500 hp, diesel	7,000 CY, 765 CY/day, 80 utility	58.56	hrs	5.50	5.50	0.00	0.00	0.00	0.00	0.00	62.67	
RAC	Grading (top soil)	Dozer, 140 HP (D6) w/A Blade (diesel)	Use 150ft X 150ft for Grading. Daily output 400 YD2	6.25	hrs	0.37	0.37	0.00	0.00	0.00	0.00	0.00	2.01	
RAC	Asphalt Paving	Paver, 100 HP (diesel)	560 yd2. Assume 3 inches. Daily output 4905 YD2	0.73	hrs	0.03	0.03	0.00	0.00	0.00	0.00	0.00	0.09	
RAC	Material Staging Area Removal (Excavator)	Excavator, Hydraulic, 2 CY (diesel)	Assume 1 day	8.00	hrs	0.78	0.78	0.00	0.00	0.00	0.00	0.00	3.52	
RAC	General Construction Debris Removal (Excavator)	Excavator, Hydraulic, 2 CY (diesel)	Assume 1 day	8.00	hrs	0.78	0.78	0.00	0.00	0.00	0.00	0.00	3.52	
Subtotal						93.94	93.93	0.00	0.00	0.32	0.08	0.05	764.91	0
Total						340	331	0.03	0.08	0.32	0.12	1.38	6,827	3



Alternative 1
Values Input into SiteWise as "Other"

Module	Greenhouse Gas Emissions				Criteria Pollutant Emission			Energy Consumption	Water Consumption
	CO ₂ e	CO ₂	N ₂ O (CO ₂ e)	CH ₄ (CO ₂ e)	NO _x	SO _x	PM ₁₀	MMBTU	gal
	Tonnes								
RI	-	-	-	-	-	-	-	-	-
RAC	340.34	330.80	7.93	1.61	0.32	0.12	1.38	23,293.66	3,381.85
RAO	-	-	-	-	-	-	-	-	-
LTM	-	-	-	-	-	-	-	-	-

Note: 1 MWhr = 3412141.4799 BTU, 1MMTBU = 10⁶ BTU

**Sustainable Remediation - Environmental Footprint Summary
 Alternative 6B**

Phase	Activities	GHG Emissions	Total energy Used	Water Consumption	NOx emissions	SOx Emissions	PM10 Emissions	Accident Risk Fatality	Accident Risk Injury
		metric ton	MMBTU	gallons	metric ton	metric ton	metric ton		
Remedial Investigation	Consumables	0.00	0.0E+00	NA	NA	NA	NA	NA	NA
	Transportation-Personnel	0.00	0.0E+00	NA	0.0E+00	0.0E+00	0.0E+00	0.0E+00	0.0E+00
	Transportation-Equipment	0.00	0.0E+00	NA	0.0E+00	0.0E+00	0.0E+00	0.0E+00	0.0E+00
	Equipment Use and Misc	0.00	0.0E+00	0.0E+00	0.0E+00	0.0E+00	0.0E+00	0.0E+00	0.0E+00
	Residual Handling	0.00	0.0E+00	NA	0.0E+00	0.0E+00	0.0E+00	0.0E+00	0.0E+00
	Sub-Total	0.00	0.00E+00	0.00E+00	0.00E+00	0.00E+00	0.00E+00	0.00E+00	0.00E+00
Remedial Action Construction	Consumables	0.00	0.0E+00	NA	NA	NA	NA	NA	NA
	Transportation-Personnel	22.58	2.8E+02	NA	8.4E-03	2.9E-04	1.7E-03	4.6E-04	3.7E-02
	Transportation-Equipment	85.45	1.1E+03	NA	2.7E-02	4.8E-04	2.4E-03	2.1E-04	1.7E-02
	Equipment Use and Misc	314.99	2.2E+04	7.4E+03	2.7E-01	1.4E-01	6.4E-01	4.7E-05	1.2E-02
	Residual Handling	30.24	3.9E+02	NA	9.5E-03	1.7E-04	8.4E-04	7.5E-05	6.0E-03
	Sub-Total	453.26	2.39E+04	7.43E+03	3.15E-01	1.44E-01	6.50E-01	7.96E-04	7.22E-02
Remedial Action Operations	Consumables	0.00	0.0E+00	NA	NA	NA	NA	NA	NA
	Transportation-Personnel	1.52	1.9E+01	NA	5.6E-04	2.0E-05	1.1E-04	3.1E-05	2.5E-03
	Transportation-Equipment	0.00	0.0E+00	NA	0.0E+00	0.0E+00	0.0E+00	0.0E+00	0.0E+00
	Equipment Use and Misc	12.97	1.9E+02	0.0E+00	4.5E-02	3.0E-02	1.1E-03	0.0E+00	0.0E+00
	Residual Handling	0.00	0.0E+00	NA	0.0E+00	0.0E+00	0.0E+00	0.0E+00	0.0E+00
	Sub-Total	14.50	2.13E+02	0.00E+00	4.55E-02	3.00E-02	1.25E-03	3.12E-05	2.51E-03
Longterm Monitoring	Consumables	0.00	0.0E+00	NA	NA	NA	NA	NA	NA
	Transportation-Personnel	0.00	0.0E+00	NA	0.0E+00	0.0E+00	0.0E+00	0.0E+00	0.0E+00
	Transportation-Equipment	0.00	0.0E+00	NA	0.0E+00	0.0E+00	0.0E+00	0.0E+00	0.0E+00
	Equipment Use and Misc	0.00	0.0E+00	0.0E+00	0.0E+00	0.0E+00	0.0E+00	0.0E+00	0.0E+00
	Residual Handling	0.00	0.0E+00	NA	0.0E+00	0.0E+00	0.0E+00	0.0E+00	0.0E+00
	Sub-Total	0.00	0.00E+00	0.00E+00	0.00E+00	0.00E+00	0.00E+00	0.00E+00	0.00E+00
Total		4.7E+02	2.4E+04	7.4E+03	3.6E-01	1.7E-01	6.5E-01	8.3E-04	7.5E-02

Remedial Alternative Phase	Non-Hazardous Waste Landfill Space	Hazardous Waste Landfill Space	Topsoil Consumption	Costing	Lost Hours - Injury
	tons	tons	cubic yards	\$	
Remedial Investigation	0.0E+00	0.0E+00	0.0E+00	0	0.0E+00
Remedial Action Construction	0.0E+00	0.0E+00	0.0E+00	0	5.8E-01
Remedial Action Operations	0.0E+00	0.0E+00	0.0E+00	0	2.0E-02
Longterm Monitoring	0.0E+00	0.0E+00	0.0E+00	0	0.0E+00
Total	0.0E+00	0.0E+00	0.0E+00	\$0	6.0E-01

Total Cost with Footprint Reduction
\$0

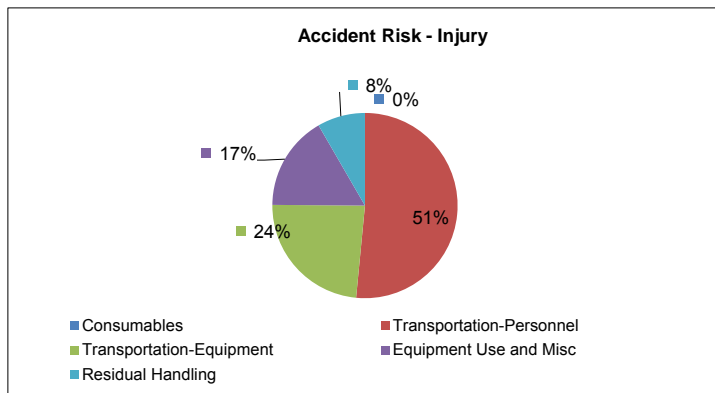
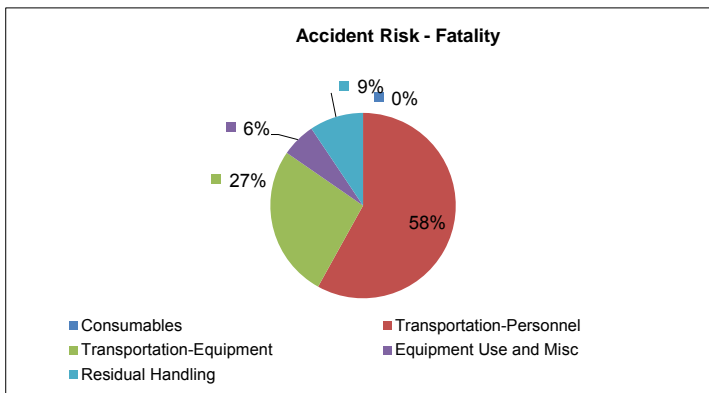
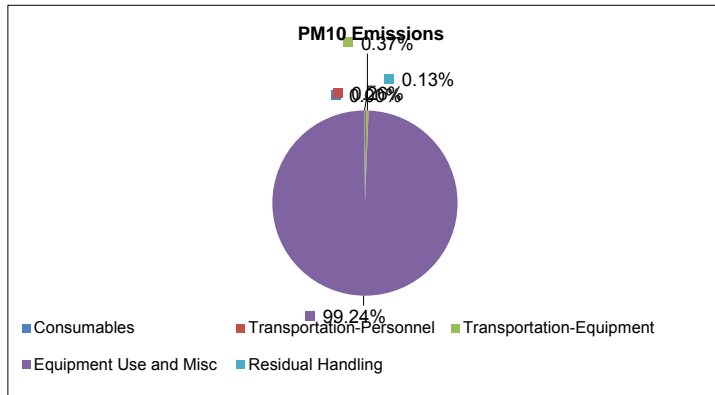
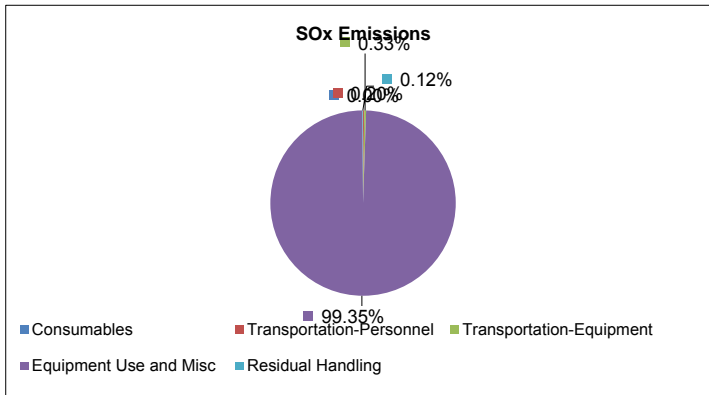
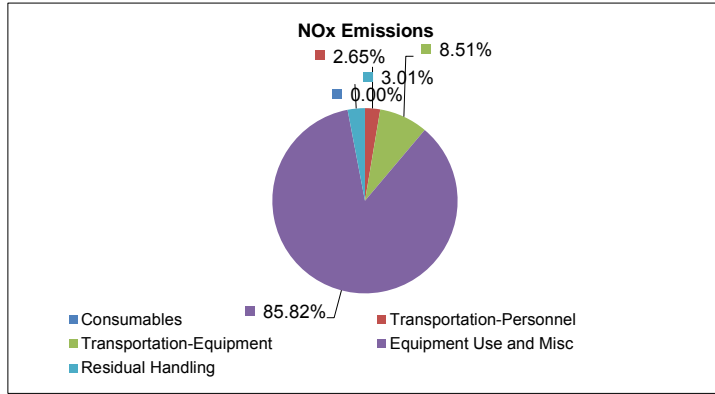
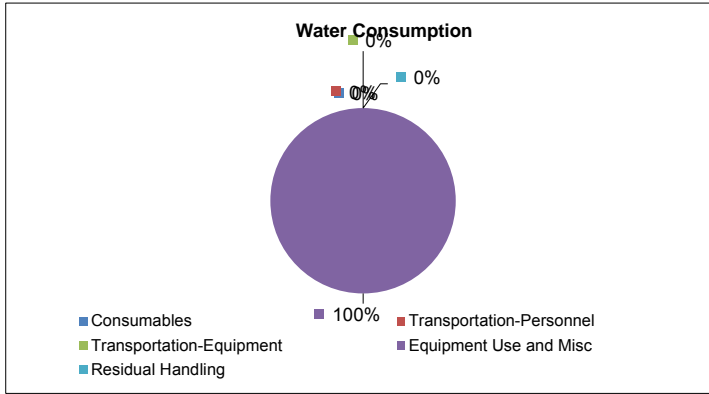
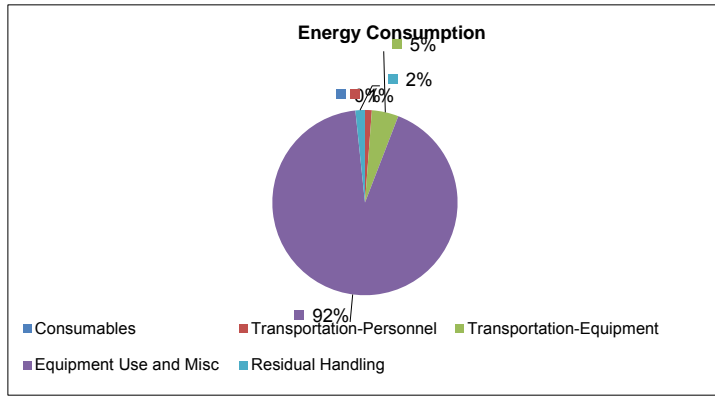
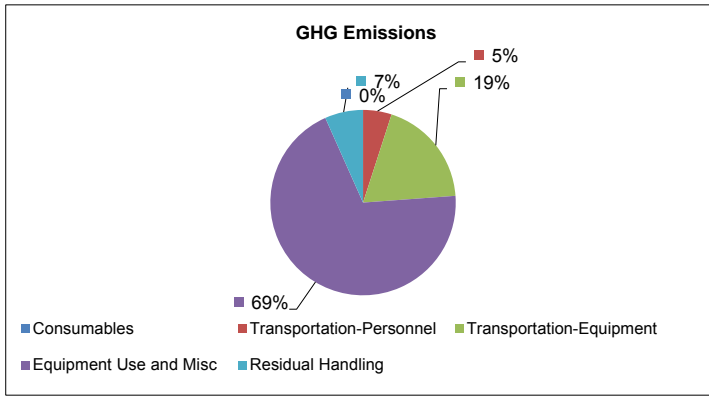

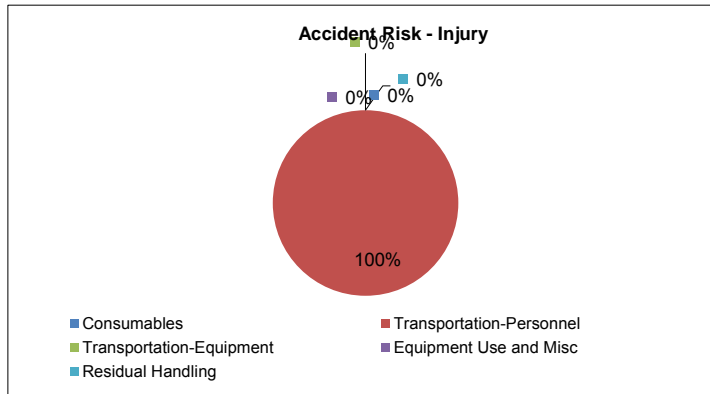
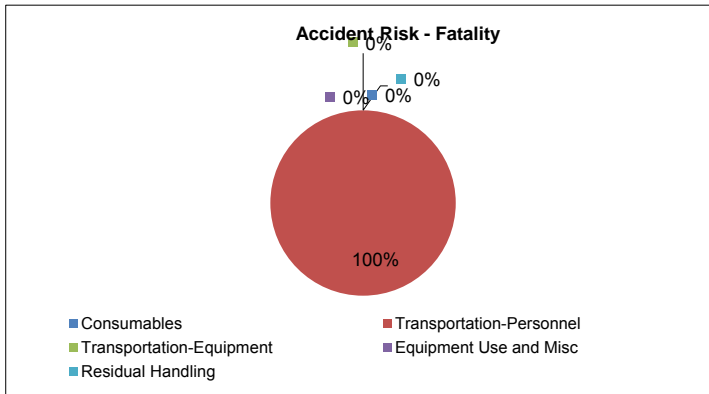
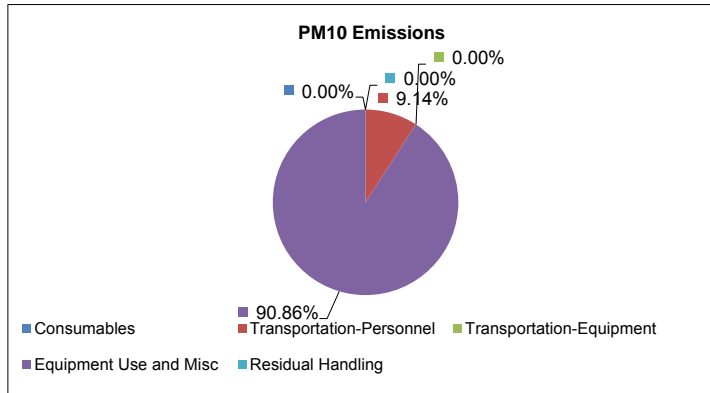
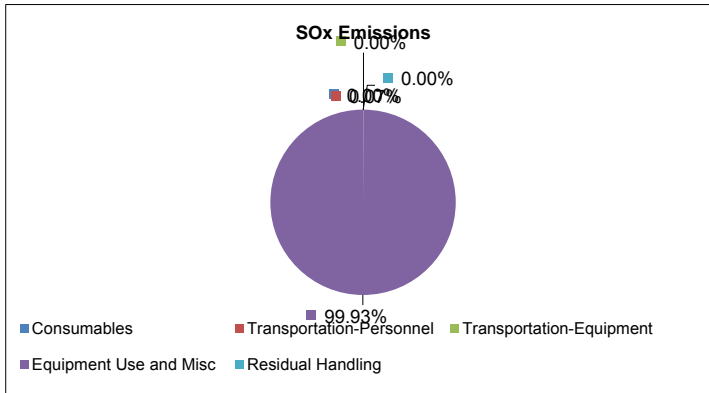
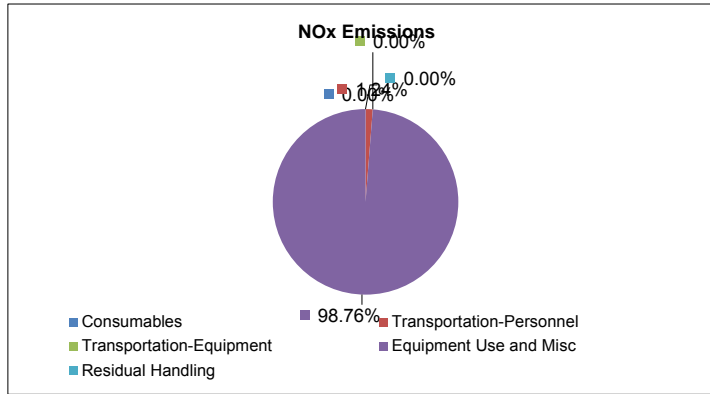
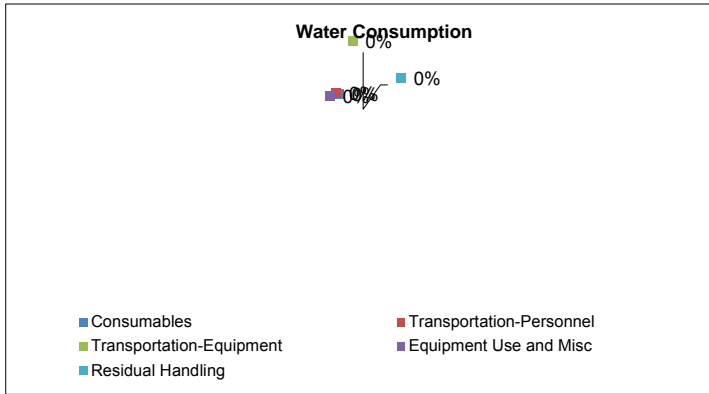
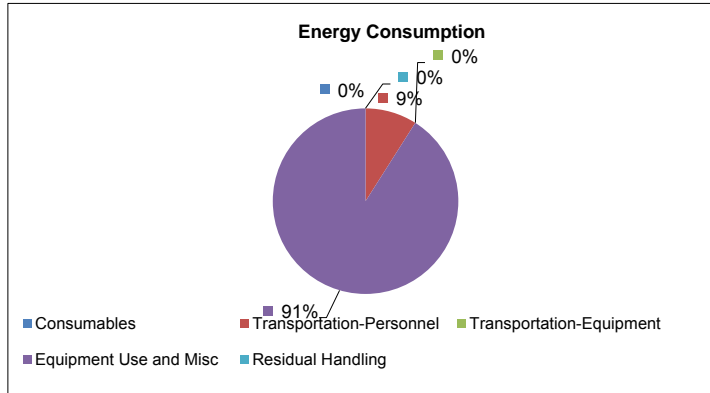
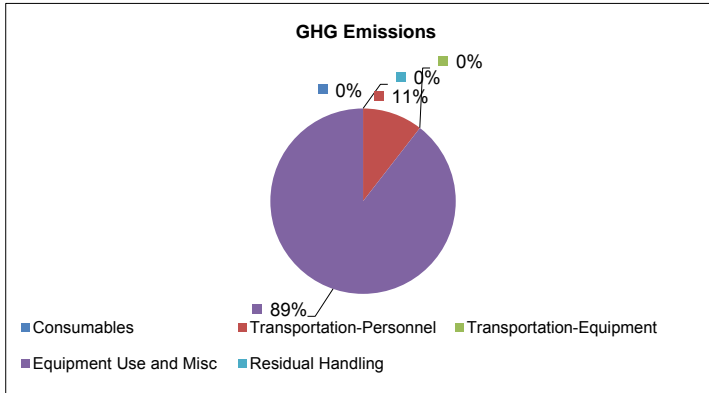

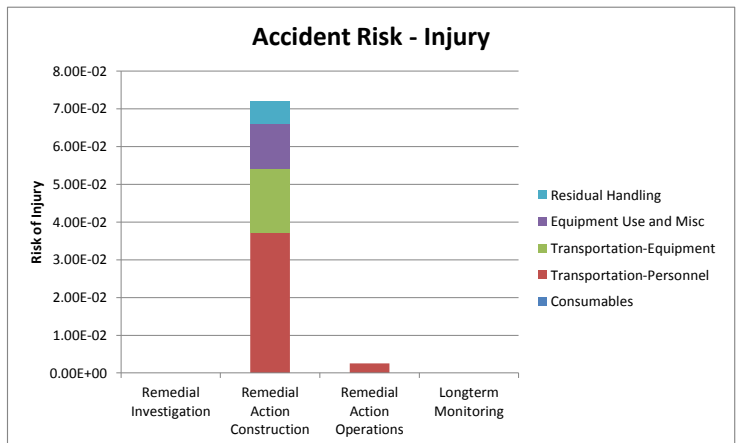
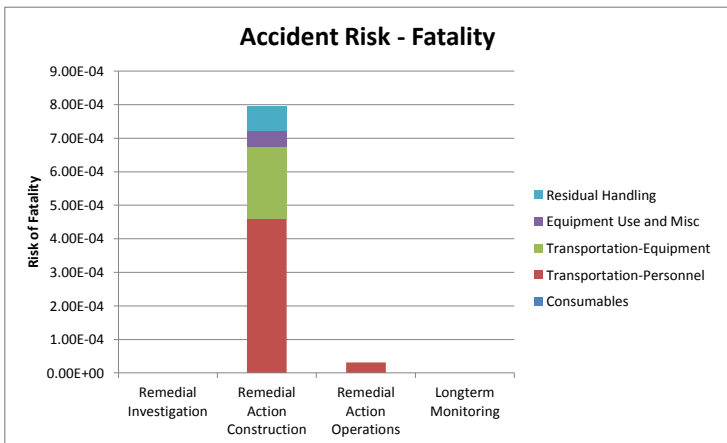
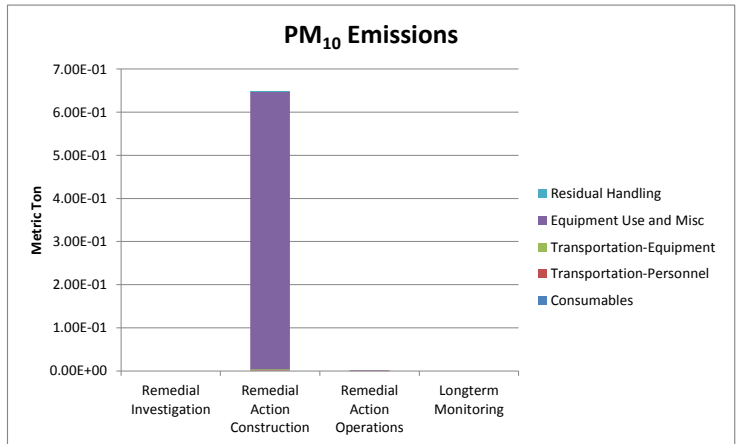
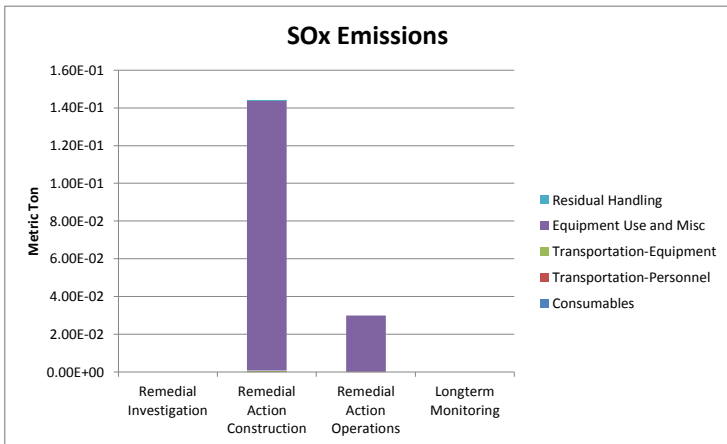
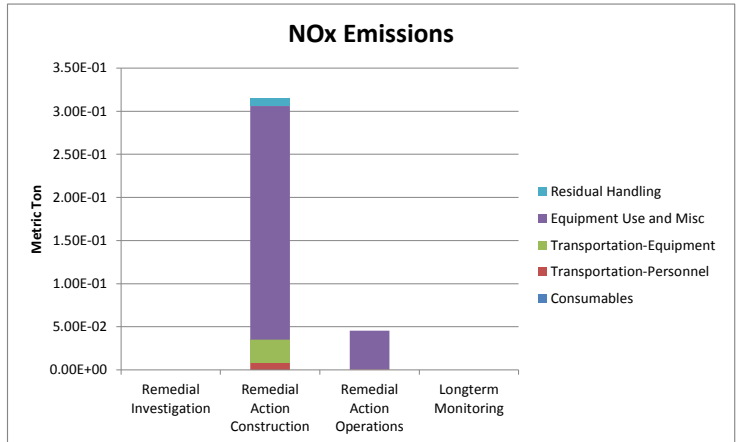
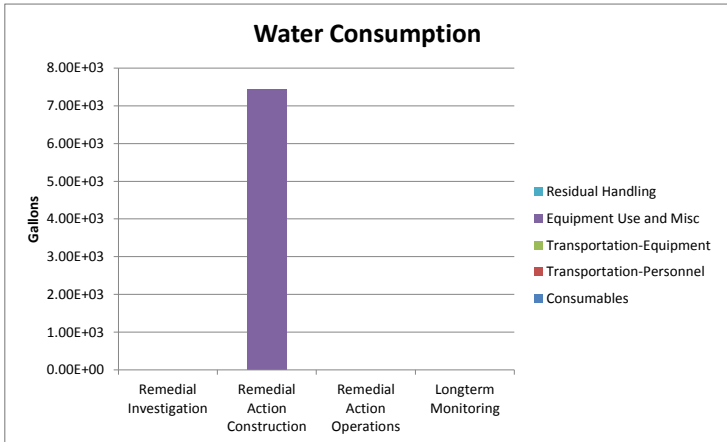
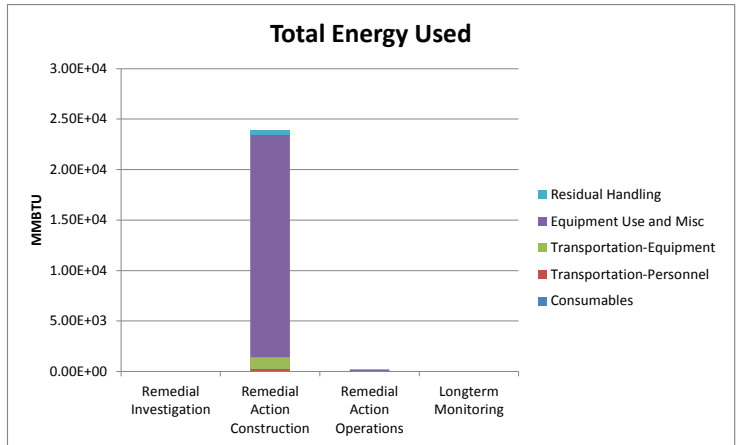
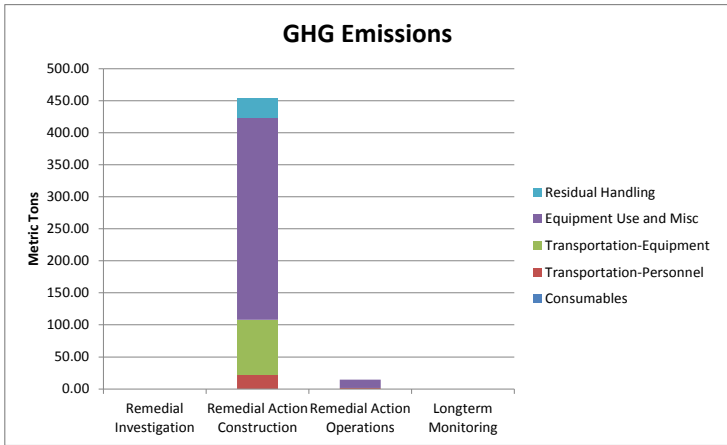

GSRx Results Alternative 6B
Site 4, Naval Weapons Industrial Reserve Plant
Bethpage, New York
Page 1 of 2

Stage	Technology Module / Phase	Module Components	Comments / Assumptions	Quantity	(Units)	Greenhouse Gas Emissions				Criteria Pollutant Emission			Energy	Water
						CO ₂ e	CO ₂	N ₂ O	CH ₄	NO _x	SO _x	PM ₁₀	Consumptio	Consumptio
						Tonnes							MW hr	gal x 1000
RAC	Monitoring Well Installation	PVC	Pipe Input	160.00	lft	0.26	0.13	0.00	0.00	0.00	0.00	0.00	4.76	0.28
RAC	Temporary Equipment Decon Pad Liner	HDPE	assume HDPE, Assume 30ftx40ft, 3 mm thick, 0.95 g/cm3	700.47	lbs	1.56	0.83	0.00	0.01	0.00	0.00	0.00	9.17	0.25
RAC	Temporary Equipment Decon Pad Frame	Wood	Assume wood, 4x4 in, (30ftx40ft pad) 140 ft of timber, density for pine 530 kg/m3	514.68	lbs	0.01	0.01	0.00	0.00	0.00	0.00	0.01	0.00	
RAC	Construction Entrance	Gravel	Assume 100 yd2 is needed for entrance, Assume 1 ft thick of gravel, 2.5 tons/CY	166,666.67	lbs	1.28	1.28	0.00	0.00	0.00	0.00	0.00	30.63	0.00
RAC	4 Material staging areas (10 ml poly/hay bales ft)	HDPE	Used the following Material handling pad info to develop wieght. HDPE Liner, 5000 sf, 10 oz/sy, 16 oz/lb, 343.75 lbs	5,280.00	lbs	11.78	6.23	0.01	0.05	0.00	0.03	0.00	69.10	1.90
RAC	Backfill (off-site Source)	Soil		21,000,000.00	lbs	219.05	219.05	0.00	0.00	0.00	0.00	0.00	5788.59	0.00
RAC	Top Soil	Soil	30 yd3, Assume 1.5 ton/cy, 2000 lb/ton	90,000.00	lbs	0.94	0.94	0.00	0.00	0.00	0.00	0.00	24.81	0.00
RAC	Repaving (Stone)	Gravel	260 yd2, Assume 6 inches thick, 145 lbs/ft3	169,650.00	lbs	1.31	1.31	0.00	0.00	0.00	0.00	0.00	31.18	0.00
RAC	Repaving (Asphalt)	Asphalt	260 yd2, Assume 3 inches thick, 145lbs/ft3	84,825.00	lbs	0.86	0.71	0.00	0.00	0.00	0.00	0.62	3.85	0.00
RAC	Revegetation seed	Fertilizer	Revegation Seed	10.00	lbs	0.01	0.01	0.00	0.00	0.00	0.00	0.00	0.23	0.00
Subtotal						237.07	230.49	0.02	0.05	0.00	0.03	0.62	5962.30	2.43
Construction Equipment						Tonnes							MW hr	gal x 1000
RAC	Drilling/Split Spoon	Drill Rig, DPT (diesel)	30 borings, 5 borings /day, 8 hrs, 80% utility	38.40	hrs	0.62	0.60	0.00	0.00	0.01	0.00	0.00	4.69	
RAC	Asphalt Removal (Excavator)	Excavator, Hydraulic, 2 CY (diesel)	260 yd2, Assume 690 yd2/day,	4.00	hrs	0.39	0.39	0.00	0.00	0.00	0.00	0.00	1.76	
RAC	Asphalt Removal (Loader)	Loader, 155 HP, 3 CY (diesel)	260 yd2, Assume 690 yd2/day,	4.00	hrs	0.08	0.08	0.00	0.00	0.00	0.00	0.00	0.34	
RAC	Sheet Piling (Crawler Crane)	Crane, 500 hp, diesel	Use FT2 of sheet piling needed. Assume 240 ft perimeter. 71 ft bgs. 25 ft depth installation described in RS Means. Daily Output = 553 ft2/day. Multiply hours by 3 due complexity in driving to 71 bgs	92.44	hrs	8.68	8.68	0.00	0.00	0.00	0.00	0.00	98.93	
RAC	Sheet Piling (Vibrator Hammer & Generator)	Vibratory Hammer, 250 hp	Consider time needed is same as above	92.44	hrs	6.83	6.83	0.00	0.00	0.05	0.00	0.00	44.90	
RAC	Excavation (2.5 CY Excavator)	Excavator, Hydraulic, 2 CY (diesel)	8,000 CY, 765 CY/day, 80 utility	66.93	hrs	6.49	6.49	0.00	0.00	0.04	0.01	0.00	29.45	
RAC	Excavation (Clamshell Crane)	Crane, 500 hp, diesel	8,000 CY, 765 CY/day, 80 utility	66.93	hrs	6.29	6.29	0.00	0.00	0.00	0.00	0.00	71.63	
RAC	Concrete UST Pad Removal and Disposal (2.5 CY Excavator)	Excavator, Hydraulic, 2 CY (diesel)	46 CY, 255 CY/day, 80 utility	1.15	hrs	0.11	0.11	0.00	0.00	0.00	0.00	0.00	0.51	
RAC	Backfill of Soils for Reuse (6600 Cu Yds) Excavator	Excavator, Hydraulic, 2 CY (diesel)	6,600 CY, 765 CY/day, 80 utility	55.22	hrs	5.35	5.35	0.00	0.00	0.03	0.01	0.00	24.29	
RAC	Backfill of Soils for Reuse (6600 Cu Yds) Clamshell Crane	Crane, 500 hp, diesel	6,600 CY, 765 CY/day, 80 utility	55.22	hrs	5.19	5.19	0.00	0.00	0.00	0.00	0.00	59.09	
RAC	Backfill (off-site Source) Excavator	Excavator, Hydraulic, 2 CY (diesel)	1400 CY, 765 CY/day, 80 utility	11.71	hrs	1.14	1.14	0.00	0.00	0.01	0.00	0.00	5.15	
RAC	Backfill (off-site Source) Clamshell Crane	Crane, 500 hp, diesel	1400 CY, 765 CY/day, 80 utility	11.71	hrs	1.10	1.10	0.00	0.00	0.00	0.00	0.00	12.53	
RAC	Grading (top soil)	Dozer, 140 HP (D6) w/A Blade (diesel)	Use 150ft X 150ft for Grading. Daily output 400 YD2	2.08	hrs	0.12	0.12	0.00	0.00	0.00	0.00	0.00	0.67	
RAC	Asphalt Paving	Paver, 100 HP (diesel)	560 yd2. Assume 3 inches. Daily output 4905 YD2	0.73	hrs	0.03	0.03	0.00	0.00	0.00	0.00	0.00	0.09	
RAC	Material Staging Area Removal (Excavator)	Excavator, Hydraulic, 2 CY (diesel)	Assume 1 day	8.00	hrs	0.78	0.78	0.00	0.00	0.00	0.00	0.00	3.52	
RAC	General Construction Debris Removal (Excavator)	Excavator, Hydraulic, 2 CY (diesel)	Assume 1 day	8.00	hrs	0.78	0.78	0.00	0.00	0.00	0.00	0.00	3.52	
Subtotal						43.96	43.94	0.00	0.00	0.15	0.03	0.02	361.07	0
Total						281	274	0.02	0.05	0.15	0.06	0.64	6,323	2



Alternative 1
Values Input into SiteWise as "Other"

Module	Greenhouse Gas Emissions				Criteria Pollutant Emission			Energy Consumption	Water Consumption
	CO ₂ e	CO ₂	N ₂ O (CO ₂ e)	CH ₄ (CO ₂ e)	NO _x	SO _x	PM ₁₀	MMBTU	gal
	Tonnes								
RI	-	-	-	-	-	-	-	-	-
RAC	281.02	274.43	5.46	1.13	0.15	0.06	0.64	21,575.36	2,432.88
RAO	-	-	-	-	-	-	-	-	-
LTM	-	-	-	-	-	-	-	-	-

Note: 1 MWhr = 3412141.4799 BTU, 1MMBTU = 10⁶ BTU