

FILE ON EDOC'S \_\_\_\_\_ YES \_\_\_\_\_ NO

SITE NAME \_\_\_\_\_

SITE # 130004

COUNTY \_\_\_\_\_ TOWN \_\_\_\_\_

FOILABLE \_\_\_\_\_ YES \_\_\_\_\_ NO

SC/PSA \_\_\_\_\_ RI/FS \_\_\_\_\_

RD \_\_\_\_\_ RA \_\_\_\_\_

SM \_\_\_\_\_ OTHER \_\_\_\_\_

NAME DESCRIPTION:

Report.hw 130004.2003-08-01. RCRA - RFI workplan

**Bayer Corporation  
Pittsburgh, Pennsylvania**

**RCRA Facility Assessment/RCRA  
Facility Investigation Work Plan  
Bayer Hicksville Facility  
Hicksville, New York**



**ENSR Corporation  
August 2003  
Document Number 04690-079**

## CONTENTS

<b>1.0 INTRODUCTION .....</b>	<b>1-1</b>
1.1 Purpose .....	1-1
1.2 Background .....	1-1
1.3 Physical Setting.....	1-2
1.4 Facility Regulatory Status.....	1-3
<b>2.0 SWMU AND AOC CHARACTERISTICS.....</b>	<b>2-1</b>
<b>3.0 WASTE CHARACTERISTICS.....</b>	<b>3-1</b>
3.1 Chemical Information.....	3-2
3.1.1 Organic Acids .....	3-2
3.1.2 Inorganic Acids.....	3-2
3.1.3 Alkalies.....	3-2
3.1.4 Amines.....	3-3
3.1.5 Catalysts .....	3-4
3.1.6 Glycols .....	3-4
3.1.7 Isocyanates .....	3-5
3.1.8 Metallic Compounds.....	3-5
3.1.9 Organic Oils.....	3-5
3.1.10 Plasticizers.....	3-6
3.1.11 Oxidizers.....	3-6
3.1.12 Phenols.....	3-6
3.1.13 Aqueous Polymer Emulsions.....	3-7
3.1.14 Resins .....	3-7
3.1.15 Solvents .....	3-7
3.1.16 Surfactants.....	3-8
3.1.17 Water Treatment Chemicals.....	3-8
3.1.18 Other Chemicals.....	3-8
3.2 Analytical Strategy .....	3-9
<b>4.0 WORK PLAN.....</b>	<b>4-1</b>

4.1 Data Quality Objectives .....	4-1
4.2 Sampling Strategy.....	4-2
4.2.1 Biased Sampling .....	4-2
4.2.2 Non-Biased Sampling .....	4-3
4.3 Field Sampling Techniques.....	4-3
4.3.1 Soil Investigation .....	4-4
4.3.1.1 Surface Soil Sampling Procedures .....	4-4
4.3.1.2 Soil Borings Using a Geoprobe .....	4-4
4.3.2 Sediment Investigation.....	4-5
4.3.3 Concrete Surfaces Investigation.....	4-5
4.3.4 Surface Water Investigation.....	4-5
4.3.5 Field Logbooks / Documentation .....	4-6
4.3.6 Chain of Custody Procedures.....	4-6
4.3.7 Equipment Decontamination .....	4-7
4.3.8 Field Equipment Calibration.....	4-7
4.4 Laboratory Analysis .....	4-7
4.4.1 Laboratory Qualifications .....	4-7
4.4.2 Sample Containers, Reagents, Preservation, and Holding Time Requirements .....	4-8
4.4.3 Analytical Methods .....	4-8
4.4.4 Quality Assurance/Quality Control .....	4-8
4.4.5 Laboratory Instrument Calibration .....	4-9
4.4.6 Data Deliverables .....	4-10
4.4.7 Data Verification and Validation .....	4-11
<b>5.0 SCHEDULE .....</b>	<b>5-1</b>
<b>6.0 RFA/RFI REPORT .....</b>	<b>6-1</b>

## LIST OF TABLES

Table 2-1	Summary of Baseline Investigation Program
Table 4-1	Summary of Sampling and Analysis Program
Table 4-2	Containers, Preservation and Holding Times for Solid Samples
Table 4-3	Analytical Methods for Solid Samples
Table 4-4	Containers, Preservation and Holding Times for Water Samples
Table 4-5	Analytical Methods for Water Samples

---

## LIST OF FIGURES

- Figure 1-1 Site Location Map
- Figure 1-2 Area of Concern Map
- Figure 2-1 Proposed Sampling Locations, AOC 1, AOC 2, AOC 27B, AOC 35B, AOC 35C & AOC 35D
- Figure 2-2 Proposed Sampling Locations, AOC 3, AOC 5, AOC 7 & AOC 27D
- Figure 2-3 Proposed Sampling Locations, AOC 4, AOC 8.1, AOC 12, AOC 13, AOC 14, AOC 27J & AOC 35F
- Figure 2-4 Proposed Sampling Locations, AOC 6, AOC 9, AOC 28, & AOC29
- Figure 2-5 Proposed Sampling Locations, AOC 16, AOC 17, AOC 18, AOC 19, AOC 27F, AOC 27I, AOC 31, AOC35E, AOC 37 & AOC 38
- Figure 2-6 Proposed Sampling Locations, AOC 17, AOC 22, AOC 24, AOC 27G, AOC 27H, AOC 31 & AOC 33
- Figure 2-7 Proposed Sampling Locations, AOC 20, AOC 21A, AOC 22 & AOC 23
- Figure 2-8 Proposed Sampling Locations, AOC 21B & AOC 27C
- Figure 2-9 Proposed Sampling Locations, AOC 27A, AOC 35A, AOC 35G & AOC 36
- Figure 2-10 Proposed Sampling Locations, AOC 30
- Figure 2-11 Proposed Sampling Locations, AOC 42, AOC 43, AOC 44, AOC 45, AOC 49
- Figure 5-1 Proposed RFI Schedule

---

## LIST OF APPENDICES

**Appendix A – Superfund Fact Sheet**

**Appendix B – SWMU/AOC Closure Documentation**

**Appendix C – Health & Safety Plan**

**Appendix D– ENSR SOPs**

SOP # 7110 Surface Soil Sampling

SOP # 7116 Subsurface Soil Sampling by Geoprobe® Methods

SOP # 7600 Decontamination of Field Equipment

Concrete Core Sampling

Sediment Sampling

**Appendix E – Method Detection Limits for Laboratory Analyses**

## 1.0 INTRODUCTION

### 1.1 Purpose

The purpose of this document is to present the Resource Conservation and Recovery Act (RCRA) Facility Assessment/RCRA Facility Investigation (RFA/RFI) Work Plan for the Bayer Corporation Facility, located in Hicksville, New York. The RFA/RFI Work Plan has been based on the correspondence between Ms. Alicia Barraza, New York State Department of Environmental Conservation (NYSDEC) and Mr. Joel E. Robinson, Bayer Corporation, dated January 8, 2003. In this correspondence the NYSDEC presented basic guidance on the completion of an RFI for the facility. Additional discussions have occurred which have modified the approach presented in the January 8, 2003 correspondence. Additional correspondence between Ms. Alicia Barraza and Mr. Joel Robinson, dated June 10, 2003, as well as notes recorded by Mr. Chris Gaule of ENSR during a May 1, 2003 site visit, and an e-mail from Ms. Katy Murphy of the NYSDEC, dated June 17, 2003, has been received regarding the draft RFA/RFI Work Plan initially submitted to the NYSDEC in March of 2003. As a result of these discussions and the referenced correspondence, ENSR International (ENSR) has prepared this RFA/RFI Work Plan on behalf of Bayer. This document is intended to fulfill the needs of both a RFA and a RFI Work Plan in an abbreviated form.

*The scope outlined in this document will be completed by ENSR on behalf of Bayer Corporation and will be completed in conjunction with other remedial actions currently underway at the facility, as part of the facility decommissioning.*

### 1.2 Background

The Bayer facility is located at 125 New South Road in Hicksville, New York (Figure 1-1). Property use surrounding the facility is primarily industrial. The facility was originally constructed in 1945, with additional construction occurring over a twenty-year period. In the early 1950s the facility produced rubber latex and poly-vinyl chloride (PVC) compounds, PVC film and sheet, plasticizers, and polyesters and around 1954 began polyvinyl chloride resin manufacturing. From 1966 through February 26, 1982, the land, buildings, machinery and equipment comprising this facility were owned and operated by the Hooker Chemical and Plastic Corporation/Occidental Chemical Company (HCPC/OCC). In the early 1980s, as a result of past practices, the HCPC/OCC Hicksville facility was declared a Superfund Site and placed on the National Priorities List (NPL) by the U.S. Environmental Protection Agency (USEPA). Under USEPA's supervision HCPC/OCC is carrying out remedial actions addressing both soils and groundwater. Further discussion of the Superfund activities at the Site is presented in Section 1.3 of this document and Appendix A.



On February 26, 1982, Ruco Polymer Corporation (Ruco), a newly formed company, purchased the facility from HCPC/OCC. As a part of the purchase agreement, HCPC/OCC agreed to indemnify Ruco for liabilities associated with any environmental issues arising out of the facility's operations conducted prior to February 26, 1982. Sybron Chemical Corporation of Birmingham, New Jersey purchased Ruco in 1998. Bayer Corporation became the owner of the facility in October 2000 as part of Bayer's acquisition of Sybron Chemicals Corporation. As the successor to Ruco, Bayer received the HCPC/OCC indemnification for liabilities associated with any environmental issues arising out of the facility's past operations. On January 1, 2003, as part of an overall corporate restructuring, the property was transferred from Bayer Corporation to Bayer Polymers LLC (Bayer).

Following acquisition of the Site, Bayer determined that the cost of continuing to operate the *manufacturing plant at Hicksville was too great proportionally to the potential return*. Bayer made the decision to transfer the Hicksville production operations to other Bayer facilities in West Virginia and Georgia. Consistent with Bayer practice to return Sites to beneficial reuse after the termination of all production operations at a Site, all the equipment, reactors, buildings, piping, tanks, and other appurtenances have been taken out of commission and closed pursuant to applicable regulations.

Figure 1-2 shows the approximately 14-acre facility layout prior to decommissioning activities. Plants 1 and 2 have been decommissioned and dismantled to their foundations. Plant 3 has been dismantled down to its structural steel. All raw materials, products and hazardous chemicals have been removed from the site.

The site is located on a 17 acre triangular shaped parcel in a light industrial setting. The property is bounded by industrial development to the north, on the east by a warehouse building owned by Northrop and to the south and west, the property is bounded by two active sidings of the Long Island Railroad as well as residential areas.

### 1.3 Physical Setting

Ground surface at the Site is relatively level, with a gentle slope toward the south. The geology underlying the Site includes a shallow Upper Glacial aquifer, consisting of glacial outwash sand and gravel deposits, and a deeper Magothy aquifer that consists of a heterogeneous deposit of sands and gravels. The sands and gravels in the Magothy aquifer are interbedded with discontinuous lenses of silty to solid clay. The Magothy aquifer is the primary source of water for municipal and industrial usage within the vicinity of the Site. Beneath the Magothy aquifer lies the Raritan confining unit, consisting of silty to solid clay with intermittent layers of sand. The Raritan confining unit represents the lower impermeable boundary of the groundwater flow system and is approximately 175 feet thick. The confining unit forms the upper member of the Raritan Formation. The fourth major hydrogeologic unit is the Lloyd aquifer, which forms the lower unit of the Raritan Formation. The Lloyd aquifer is composed of fine to coarse sand and is approximately 300 feet thick.

Precipitation recharge, stormwater runoff and industrial water discharge and recharge basins and sumps assist in sustaining the aquifers. The groundwater flow typically runs from north to south and is predominantly influenced by the effects of municipal and industrial pumping centers and recharge basins.

The Site is not known to have an impact on ecologically significant habitat, wetlands or agricultural land in the area.

#### **1.4 Facility Regulatory Status**

Past facility operations and known waste disposal methods are known to have contaminated the subsurface soils and groundwater at the Site. For instance, it has been established that from 1956 to 1975, plant wastewater containing volatile organic compounds (VOCs) and heavy metals was discharged into six on-site groundwater recharge basins, which led to contamination of the on-site groundwater. Also, from 1946 to 1978, a heat transfer fluid containing polychlorinated biphenyls (PCBs) was utilized as part of plant operations, which contributed to on-site PCB releases. As a result, the Hicksville facility, known as the Hooker/Ruco Site, is currently on the NPL, and is undergoing investigation and remediation in several areas under the guidance of the USEPA and NYSDEC. Under the Comprehensive Environmental Response, Compensation and Liability Act (CERCLA) investigations conducted at the facility, several Operable Units (OUs) have been identified and Records of Decision (RODs) issued, as follows:

- 00 Sitewide
- 01 On-Site Soil and Groundwater (EPA/ROD/R01-94/235, 1/28/1994, OU 01)
- 02 PCB Soil Removal (EPA/ROD/R02-90/121, 9/28/1990, OU 02)
- 03 Off-Site Groundwater

The areas previously and currently being addressed by Ruco under the above RODs are shown on Figure 1-2.

OU 01 for this Site covers the entire Ruco property and the soil and groundwater contamination from previous disposal activities. OU 02 addressed PCB-contaminated soils. A third operable unit, OU 03, consists of contaminated groundwater downgradient of the Ruco property boundary.

#### **R01-94/235 ROD for OU 01**

This ROD was issued for groundwater and soil contaminated with PVC, styrene/butadiene, vinyl chloride, vinyl acetate copolymer, polyurethane, trichloroethene, barium, cadmium, and organic acids.

From 1986 through 1988, several sampling programs were undertaken to further define the extent of contaminants in the shallow soils and groundwater around the plant. Remedial Investigation/Feasibility Study (RI/FS) field work commenced in 1989 and was completed in 1990 with a draft RI Report submitted in 1990 which summarized the investigation throughout the site to that date. Portions of the RI Report pertaining to the PCB contaminated areas were approved, in order to expedite the remediation of those areas. The complete RI report was approved in 1992. An FS outline for OU 01 was submitted in 1992 containing the preliminary groundwater and soil treatment alternatives. The USEPA regional administrator signed a Unilateral Administrative Order (UAO) in 1991. Notices of Intent to Comply with the order were submitted by both HCPC/OCC and Ruco (both dated July 16, 1991) and were received by the USEPA in 1991. The Remedial Design/Remedial Action (RD/RA) Work Plan Outline was received in 1991, followed by the RD/RA Work Plan later in 1991. Notice from HCPC/OCC for Final Inspection was received in 1992. An inspection visit was made in 1992 and final approval was issued in 1993.

OU 01 addresses the control (and remediation) of the groundwater beneath the Ruco property and the soils in the following areas:

- Soils beneath sump 1;
- Surficial soils in the former drum storage area;
- Soils beneath sump 2; and
- Surficial soils around monitoring well E (shown on Figure 1-2).

The selected remedial action for soils at the Site includes:

- additional soil testing to determine if contaminants are present in the deep soils and to compare the levels present to the soil cleanup criteria;
- soil flushing for the deep soils in sump 1 and possibly sump 2 (soil flushing by the discharge of treated groundwater and recapture by groundwater extraction wells);
- treatability studies (i.e., soil column tests) to evaluate the effectiveness of soil flushing on tentatively identified compounds (TICs);
- soil testing in the area around monitoring well E;

- excavation and off-site disposal of soils in the former drum storage area and possibly the area around monitoring well E;
- monitoring of the groundwater extraction system to assure adequate control is maintained;
- periodic sampling of the groundwater treatment system discharge; and
- use of institutional controls in the form of deed restrictions and groundwater use restrictions.

As stated above, on-site activities related to the above remedial measures for subsurface soil and groundwater contamination continue and are being handled by HCPC/OCC.

#### **R02-90/121 ROD for OU 02**

This ROD was issued for the soil and debris contaminated with organics and PCBs across the Site. Since 1984, Site investigations have identified four on-site areas of PCB contamination. These areas included:

- a direct spill area where releases of heat transfer fluid escaped through a relief valve at the pilot plant;
- a transport area contaminated by PCBs spread from the direct spill area by on-site truck traffic;
- the recharge basin that was contaminated by surface runoff; and
- soil contamination around an underground storage tank (UST) utilized for fuel storage, which was disposed of off-site in 1989.

Contaminated soil generated during the removal of the tank was stored on-site prior to its subsequent disposal off-site.

The major components of the selected remedy under this ROD were the following:

- Excavation of PCB-contaminated soils in excess of 10 ppm in the direct spill area and the transport areas surrounding the pilot plant. Soils at the bottom of the recharge basin (sump 3) were excavated to ten feet from the existing surface. Confirmatory sampling was performed to ensure soils that remained after the excavation did not have PCB concentrations above 10 ppm.

- Excavated soils with PCB concentrations between 10 ppm and 500 ppm (approximately 1,100 cubic yards) were shipped for disposal to an off-site chemical waste landfill permitted under the Toxic Substance Control Act (TSCA).
- Stockpiled soils, which were previously excavated during the removal of the underground fuel oil tank, were included in the disposal of PCB-contaminated soils at an off-site chemical waste landfill.
- Soils with PCB concentrations exceeding 500 ppm (approximately 36 cubic yards) were shipped off-site to a TSCA-permitted incineration facility. Residuals were disposed of, as appropriate, by the incineration facility.
- Excavated areas were backfilled with clean soil. These areas, excluding the recharge basin, have been paved with asphalt as appropriate.
- The PCB-contaminated soils in former sump 5 were left in-place due to the depth at which PCBs were detected (10 feet below ground surface) and the low concentration.

On-site activities for the OU 02 remedial actions started on December 3, 2001 and were completed by January 22, 2002 with the rehabilitation of the excavated area (i.e., fence replacement). The PCB immunoassay and preliminary laboratory results for the confirmatory soil samples were submitted on December 11, 2001, minor additional excavation was performed in the area of sample OP-4 on December 27, 2001. The PCB immunoassay and preliminary laboratory results for the confirmatory soil samples collected on December 27, 2001 show that compliance with the criteria of 10 ppm has been achieved. The initial excavation was backfilled on December 27, 2001.

#### **OU 03 – Off-Site Groundwater**

This operable unit consists of the off-site groundwater plume that impacted by VOCs. The off-site VOC plume has migrated off-site to the downgradient Grumman and Navy Facility. Investigation and remediation of this area of concern (AOC) is being completed by HCPC/OCC and is ongoing.

#### **Ruco Polymer Manufacturing Plant**

The subject facility has been undergoing decommissioning and demolition activities since August 2002. Activities have included:

- the removal of all on-site raw chemicals, products and non-hazardous and hazardous wastes to off-site vendors or other Bayer facilities
- identification and removal of asbestos from process equipment and buildings

- cleaning of the less than 90-day storage areas in Plant 1 and 3 (see below)
- obtaining the necessary permits to close the various aboveground storage tanks
- demolishing of Plants 1 and 2, the Pilot Plant and Tank farm (these structures have been demolished to the surface concrete slabs - no subsurface demolition was conducted)

The Ruco Polymer Manufacturing Plant was a large quantity generator pursuant to 6 NYCRR Part 370. Wastes were accumulated at or near the point of generation and then located to less than 90-day storage areas in Plant No. 1 and 3 for consolidation prior to shipment off-site. Pursuant to 6 NYCRR Part 373-1(d)(iv) the Site is located over a sole source aquifer as it is located in Nassau County and thus the area where the hazardous waste was consolidated prior to shipment must meet the closure requirements of 6 NYCRR Part 373-3.7 (a) through (f). The surface areas of these storage areas have been cleaned. As per subsequent discussions with the NYSDEC, it was agreed that additional investigative activities of these areas, if determined to be necessary, would be part of the subject RFI.

In addition to the hazardous waste storage areas discussed above, Bayer identified a number of other solid waste management units (SWMUs)/AOCs at the Site that need to be addressed as related to Ruco Site activities. These areas were identified to the NYSDEC in the document entitled "Comprehensive Site Closure Plan for the Hicksville Facility" dated October, 2002. In addition to these SWMUs/AOCs, the NYSDEC identified additional areas for consideration during its December 2002 Site visit, and subsequent May 1, 2003 site review.

The remainder of this document presents the combined RFA/RFI work plan to address the SWMU areas identified for this facility.

The following sections present a summary of the SWMUs/AOCs at the Site, the need to perform investigations at each of the SWMUs/AOCs and the methods to be implemented during the completion of the RFI. The focus of this RFI Work Plan will be to investigate the identified SWMUs/AOCs that Bayer has determined to be their responsibility. For the purpose of this investigation and previous understanding with the NYSDEC, this investigation is focused on the associated subsurface and near surface soils to a depth of approximately six feet. As stated earlier, subsurface soils below 6 feet and groundwater are being addressed in the ongoing Superfund activities being conducted by others. However, it is recognized that based on field conditions, visual and/or olfactory evidence, or equipment readings, additional sampling at depths greater than six feet may be necessary.

## 2.0 SWMU AND AOC CHARACTERISTICS

The closure of the facility, which includes plans for decommissioning and demolition of the facility, has been performed predominately by Bayer personnel. During the decommissioning process, Bayer and ENSR personnel completed reviews of historical reports and drawings and interviewed plant personnel to determine where Site contamination might have occurred while Bayer operated the facility. Additionally, field observations for stained soils or stressed vegetation were made to identify potential areas for further investigation prior to final Site closure. The Site has been divided into several areas. Forty eight potential SWMUs/AOCs have been identified within these areas as shown on Figure 1-2. Exterior SWMUs/AOCs were located with a global positioning system prior to demolition activities so that they could be relocated for RFA/RFI field activities.

Plant No. 1 includes the plant and the Warehouse attached via a walkway to the southwest end of Plant No. 1. Under Ruco, Plant No. 1 was used to produce polyester as polyurethane in water from 1982 onward. SWMUs/AOCs in the vicinity of Plant No. 1 are identified in Table 2-1 and on Figure 1-2.

Plant No. 2 includes the plant as well as the waste accumulation and compaction area southeast of the plant and the tanks located outside of the northeast wall of Plant No. 2. Under Ruco, Plant No. 2 was used to produce polyester as polyurethane in solvent and polyurethanes in water from 1982 onward. SWMUs/AOCs in the vicinity of Plant No. 2 are identified in Table 2-1 and on Figure 1-2.

Plant No. 3 includes the waste accumulation area in the plant as well as the adipic acid silos located outside of the southeast wall of Plant No. 3. SWMUs/AOCs in the vicinity of Plant No. 3 are identified in Table 2-1 and on Figure 1-2.

The Pilot Plant was used to produce solid polyurethane and polyesters from 1985 to about 2000. SWMUs/AOCs in the vicinity of the Pilot Plant are identified in Table 2-1 and on Figure 1-2.

The heating system (which includes the Cooling Tower Sump – AOC 31) contains the building/space heating sub-system and process heating sub-system. Asbestos containing material associated with the piping and valve insulation in the building/space heating system has been quantified and disposed of via a certified contractor. The process heating system in Plant No. 1 and the Pilot Plant may have originally contained PCB containing heat transfer fluid. This was replaced during Ruco ownership of the facility. The therminol system was drained and the heat transfer fluid was reclaimed. The heat transfer fluid was tested prior to reclamation and no PCBs were detected. As a result no further action is warranted for this AOC. Note that the cooling tower sump (AOC 34) will be investigated separately during the RFA/RFI investigation.

Due to the past manufacturing operations, some of the interior surfaces of the building and floors were coated with raw material and product dust. During the closure process removal of the dust and other deposits on surfaces was conducted and the materials were disposed of off-site. Additionally, as identified on Figure 1-2 some of the concrete floors in the plant areas (i.e., AOC ID Nos. 3, 4, 7, 12, 15, and 23) and the concrete pad south of the administration building (AOC 36) have suspected contamination. Cores of the concrete will be drilled to determine the depth of contaminate penetration, if any. Cores will be obtained within close proximity to cracks, if they exist. At all locations where concrete is sampled, the soils below will also be sampled in order to characterize the environmental conditions below the building slabs.

Table 2-1 presents a summary of each SWMU/AOC, including the rationale for the ongoing investigations for each of the areas and/or the rationale for no further action under the RFA/RFI by Bayer Corporation.

The following sub-sections identify each of the SWMUs/AOCs by area across the Site. Where available, specific information for each SWMU/AOC has been provided. Additional detail concerning the SWMUs/AOCs and the rationale for the completion of Site investigations is also presented in Table 2-1. Documentation pertaining to the closure of select SWMUs/AOCs is provided in Appendix B.



---

**SWMU/AOC 1: Less Than 90 Day Storage Area**

Photo of a portion of the former storage area.

- **Timeframe of Operation:** At least 1985 – 2002.
- **Material Handled and Type:** Solid and liquid hazardous and non-hazardous wastes.
- **AOC Dimensions/Volumes of Materials/Tank Size:** AOC dimensions and volume of material stored are ill-defined based on records review.
- **Brief Description:** This storage area was located inside Plant No. 1. Small amounts of hazardous wastes were stored in this area in secondary containment for less than 90 days before being shipped off site for disposal.
- **Flooring/Surface Type:** Concrete.
- **Current Condition :** All waste has been removed and the area has been cleaned. The adjacent walls have been demolished.

**SWMU/AOC 2: Laboratory Satellite Accumulation Area**

A portion of the laboratory satellite accumulation area.

- **Timeframe of Operation:** Unknown.
- **Material Handled and Type:** Flammable, hazardous solid and liquid wastes.
- **AOC Dimensions/Volumes of Materials/Tank Size:** Approximately two 55-gallon drums.
- **Brief Description:** The satellite accumulation area was located outside, south of the western corner of Plant No. 1. The area was used to temporarily store flammable waste containing solvents and polymers that were generated from laboratory research and development and quality control activities. These wastes were stored in secondary containment under a shed roof. The accumulation area was in use during the 1980s as indicated by various RCRA inspection reports. RCRA inspection documentation from 1984 indicated that the area consisted of two drums within a steel pan dike. Liquid wastes were reportedly poured into the drums through a funnel.
- **Flooring/Surface Type:** Concrete.
- **Current Condition:** No waste remains. The concrete pad is in place. The adjacent walls have been demolished.

---

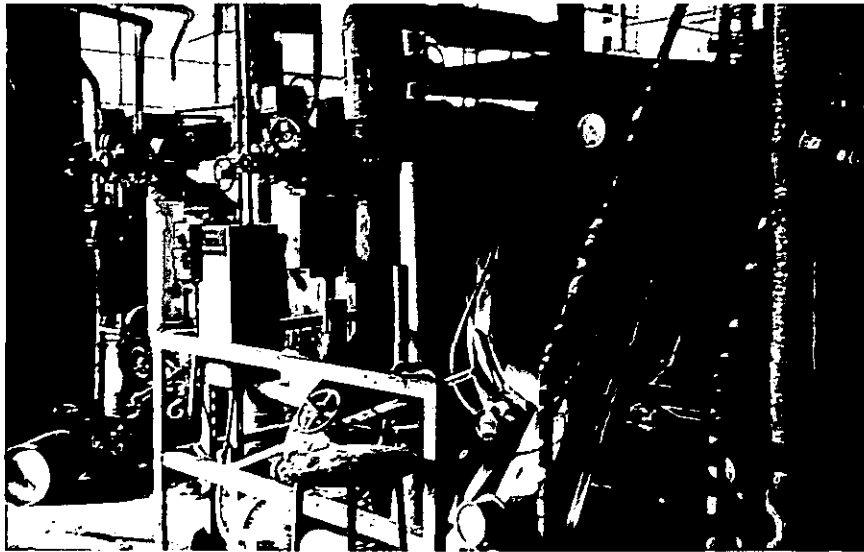
**SWMU/AOC 3: Wastewater Tanks 1, 11A, and 11B**

Some of the wastewater storage tanks and associated piping.

- **Timeframe of Operation:** Unknown to 2002. Primary use believed to be between 1982 and 2002.
- **Material Handled and Type:**
  - 1987: Propylene glycol (Tank 1) and wastewater associated with foam polyester production (Tanks 11A and 11B).
  - 1996: Distillate liquid wastewaters and low-ester liquids.
- **AOC Dimensions/Volumes of Materials/Tank Size:** Three 5,000-gallon ASTs.
- **Brief Description:** These storage tanks were located inside Plant No. 1, near the southern corner of the building. Facility documents from 1987 indicate that propylene glycol and foam polyester were stored in these tanks while documents from 1996 indicate that the tanks were used to store distillate wastewater. The distillate liquid wastes and low-ester liquids traveled via pipes to the storage tanks. From 1983 on, distillate wastewater was shipped off site to the Passaic Valley (NJ) Publicly-Owned Treatment Works (POTW) for treatment.
- **Flooring Type:** Concrete.
- **Current Condition:** The tanks have been removed and demolished. The concrete floor remains.

**SWMU/AOC 4: Former Liquid Incinerator**



View of the former liquid incinerator area.

- **Timeframe of Operation:** Late-1970s to approximately 1985.
- **Material Handled and Type:** Non-hazardous, low BTU, ester contaminated polyester-distillate waste liquids.
- **AOC Dimensions/Volumes of Materials/Tank Size:** An unknown volume of liquids were handled by the former liquid incinerator.
- **Brief Description:** Non-hazardous, low BTU, ester contaminated polyester-distillate waste was incinerated in this area using a Hirt Combustion Engineering incinerator. During this time, the distillate was sometimes shipped off site to commercial disposal facilities. Facility documents from 1996 indicate that a fume incinerator was present at this location.
- **Flooring/Surface Type:** Concrete.
- **Current Condition:** The incinerator was removed. The concrete floor of the boiler house remains, but the walls have been demolished.

## SWMU/AOC 5: Transfer Station and Associated Piping



A portion of the transfer station and piping behind Plant No. 1.

- **Timeframe of Operation:** 1950s – 2002.
- **Material Handled and Type:** Liquid raw materials.
- **AOC Dimensions/Volumes of Materials/Tank Size:** Unknown volume.
- **Brief Description:** This transfer station was where bulk liquid raw materials were unloaded and transferred into storage tanks in Plant No. 1. The area was not shown on the available historical facility maps.
- **Flooring/Surface Type:** Concrete and gravel.
- **Current Condition:** No wastes or raw materials remain.

---

**SWMU/AOC 6: Glycol Tanks #29 and #30 Transfer Station**

NO PHOTOGRAPH AVAILABLE

- **Timeframe of Operation:** At least 1975 – 2002.
- **Material Handled and Type:** Ethylene glycol/propylene glycol blend, diethylene glycol, and/or neopentyl glycol.
- **AOC Dimensions/Volumes of Materials/Tank Size:** Two 20,000-gallon tanks.
- **Brief Description:** The two 20,000-gallon ASTs were reportedly installed in 1975. The steel tanks are located within a concrete diked area to the southwest of the southern corner of Plant No. 1. Records from 1982 and 1987 indicate that the tanks were used to store ethylene glycol, propylene glycol, and diethylene glycol. Records from 1996 indicate that ethylene glycol and neopentyl glycol were stored in the tanks. A facility drawing from 1968 shows two tanks in that area, but numbered as Tank #22 and Tank #23.
- **Flooring/Surface Type:** Unlined, gravel.
- **Current Condition:** Tanks 29 and 30 have been removed. The dike walls have been removed, but the foundation remains in place.

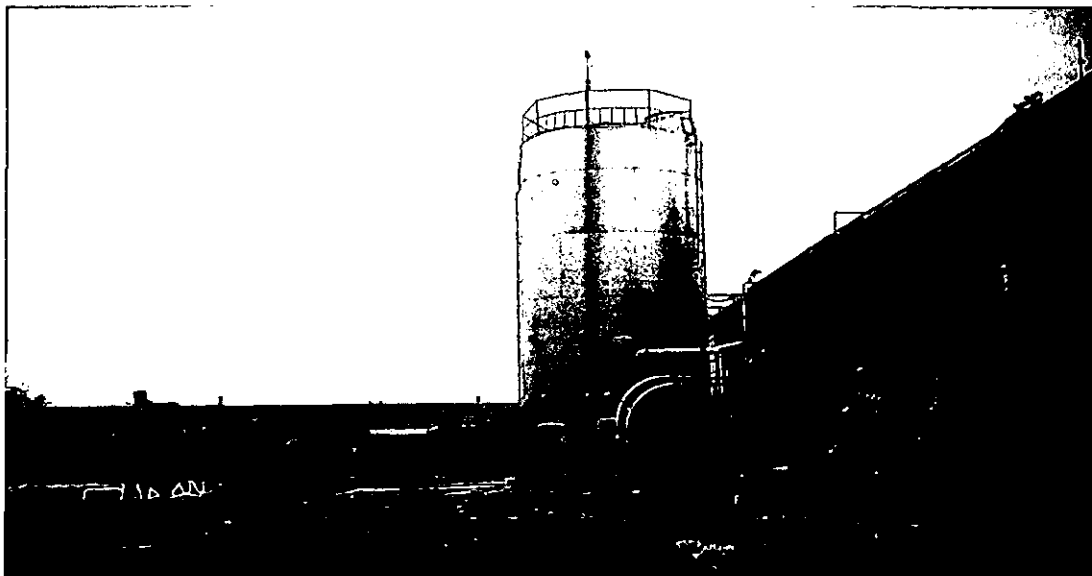
**SWMU/AOC 7: Adipic Acid Silos and Wastewater Area**

The adipic acid silos and wastewater transfer station.

- **Timeframe of Operation:**

Adipic acid storage: Early-1960s – 2002.

Wastewater Transfer Station: Mid-1980s – 2002.

- **Material Handled and Type:** Adipic acid and terephthalic acid powders, wastewaters transferred from the SWMU/AOC 3 tanks. .
- **AOC Dimensions/Volumes of Materials/Tank Size:** Two 4,000 cubic foot silos; volume of liquid handled at the wastewater transfer station is ill-defined.
- **Brief Description:** The two 4,000-cubic foot silos were located outside the southern corner of Plant No. 1. The silos were reportedly installed in 1975 and have been used to store adipic acid and terephthalic acid. The transfer station is immediately adjacent. The wastewater transfer station handled wastewater similar to that from SWMU/AOC 3 and SWMU/AOC 4.
- **Flooring/Surface Type:** The silos are constructed of steel and the surrounding ground surface is covered in concrete and asphalt.
- **Current Condition:** The adipic acid silos have been removed. The interior wastewater tanks and associated piping have also been removed. The transfer station concrete and asphalt remains in place.

**SWMU/AOC 8: Underground Storage Tanks**

Area with two fuel oil USTs that were closed in place in 1989.

- **Timeframe of Operation:** Unknown - 1989.
- **Material Handled and Type:** No. 6 Fuel Oil.
- **AOC Dimensions/Volumes of Materials/Tank Size:** Two 10,000 gallon tanks
- **Brief Description:** The date of installation of the tanks is not known; however, the tanks are shown on a 1968 facility drawing. Site records indicate the that tanks were used to store No. 6 fuel oil. The tanks were closed in place in 1989 by filling them with sand and paving over the area.
- **Flooring/Surface Type:** The tank construction is unknown; the ground surface is covered with asphalt and/or concrete.
- **Current Condition:** The USTs were closed in place.

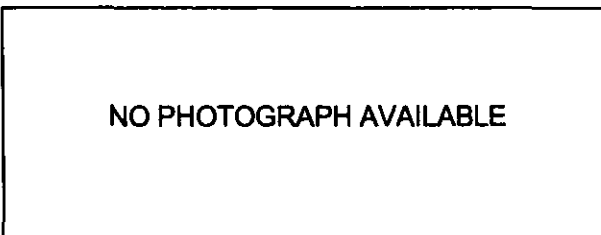

---

**SWMU/AOC 9: Underground Storage Tank Area**

- **Timeframe of Operation:** Unknown – late-1980s (prior to July 1987).
- **Material Handled and Type:**
  - 1960s: Plasticizers
  - 1980s: No. 2 Fuel Oil and No. 6 Fuel Oil
- **AOC Dimensions/Volumes of Materials/Tank Size:** Two 24,000-gallon tanks and two 25,000-gallon tanks. Note: The tanks may have been subdivided into two tanks with three 8,000-gallon sections and two tanks with two 12,500-gallon sections.
- **Brief Description:** This UST area was formerly located south of Plant No. 1. The installation date of the tanks is not known, but they are shown on a 1968 facility map. The tanks were closed in the late-1980s. Documents reviewed dated 1982 show two empty 24,000 gallon tanks and two 25,000 gallon tanks, one containing No. 2 Fuel Oil, the other containing No. 6 Fuel Oil. The tanks in this area previously contained plasticizers, including dioctylphthalate, diisooctylphthalate, diisodecylphthalate, and diisooctyl adipate.
- **Flooring/Surface Type:** Tank construction materials are unknown.
- **Current Condition:** These tanks were closed and removed as part of the Superfund activities in the area.

**SWMU/AOC 10: Underground Storage Tank**

The former location of fuel tank #3.

- **Timeframe of Operation:** The tank was installed between 1968 and 1982 and removed in 1993.
- **Material Handled and Type:** No. 2 Fuel Oil.
- **AOC Dimensions/Volumes of Materials/Tank Size:** One 3,000-gallon UST.
- **Brief Description:** This 3,000-gallon UST used to store fuel oil was located in the yard east of Plant No. 1. The UST was removed in 1993; removal of this UST generated the former soil pile designated as SWMU/AOC #25.
- **Flooring/Surface Type:** Tank construction unknown.
- **Current Condition:** The tank has been removed.

**SWMU/AOC 11: Boiler Condensate Run-Off**

Area where runoff of boiler condensate occurred.

- **Timeframe of Operation:** Unknown.
- **Material Handled and Type:** Boiler condensate and descaling solutions, possibly including sodium hydroxide, sodium salts of nitrilotriacetic acid, hexametaphosphate, hydrazine, and sulfite.
- **AOC Dimensions/Volumes of Materials/Tank Size:** Unknown volume of release.
- **Brief Description:** This was a release area adjacent to the boiler in Plant No. 1, between Plant No. 1 and the Pilot Plant. The released materials were boiler condensate with boiler treatment chemicals, primarily descaling solutions. According to a 1986 document, the following boiler treatment chemicals were used at the site: sodium hydroxide, sodium salts of nitrilotriacetic acid and hexametaphosphate, hydrazine, and sulfite.
- **Flooring/ Surface Type:** Concrete and asphalt.
- **Current Condition:** The origination point (the boilers) have been removed. The concrete and asphalt remains in place.

**SWMU/AOC 12: Non-Hazardous Waste Recyclables Accumulation Area**

Portion of the waste accumulation area.

- **Timeframe of Operation:** Unknown – 2002.
- **Material Handled and Type:** scrap metal and corrugated paper products.
- **AOC Dimensions/Volumes of Materials/Tank Size:** Unknown volume of material accumulated in area, dimensions of the AOC are ill-defined based on the records review.
- **Brief Description:** Scrap metal and corrugated paper wastes were accumulated in roll-offs and/or dumpster bins. These were non-hazardous materials that were removed when the roll-offs were filled, between once per week (for the corrugated paper products) and once per quarter (for the metals).
- **Flooring/ Surface Type:** Grass and gravel.
- **Current Condition:** No waste or recyclable materials remain.

---

**SWMU/AOC 13: Former RCRA Greater Than 90 Day Storage Area**

NO PHOTOGRAPH AVAILABLE

- **Timeframe of Operation:** Unknown – 1985.
- **Material Handled and Type:** Flammable waste containing solvents and polymers.
- **AOC Dimensions/Volumes of Materials/Tank Size:** Up to 700 55-gallon drums.
- **Brief Description:** The former greater than 90-day storage area was located on a concrete pad adjacent to Plant No. 2. Ruco closed this area shortly after purchasing the facility in order to obtain Small Quantity Generator status. Approximately 600 to 700 drums of material were removed from the area during closure. There were a number of damaged drums in the area (holes, dents) which were subsequently crushed prior to disposal.
- **Flooring/ Surface Type:** Concrete.
- **Current Condition:** No waste remains. The concrete pad is in place. The area was closed with NYSDEC oversight, pending future groundwater and subsurface investigations.

#### SWMU/AOC 14: Waste Compactor and Scrap Metal Area



The waste compactor and scrap metal area adjacent to Plant No. 2.

- **Timeframe of Operation:** Late-1950s to 2002.
- **Material Handled and Type:** Non-hazardous trash, bags, packing materials, etc.
- **AOC Dimensions/Volumes of Materials/Tank Size:** One or two waste compactors and one roll-off container.
- **Brief Description:** The waste compactor and roll-off accepted non-hazardous trash, bags, packing materials, etc. from the entire site. Waste was removed several times per week for off-site disposal.
- **Flooring/Surface Type:** Concrete
- **Current Condition:** No waste remains. The compactor has been removed. The concrete pad is in place. The adjacent walls have been demolished.

---

**SWMU/AOC 15: Distillate Wastewater Tank, Plant 2**

NO PHOTOGRAPH AVAILABLE

- **Timeframe of Operation:** At least 1955 – 2002.
- **Material Handled and Type:**
  - 1955: Unknown
  - 1987: Empty
  - 1996: Distillate wastewater
- **AOC Dimensions/Volumes of Materials/Tank Size:** One 3,750-gallon AST.
- **Brief Description:** The distillate wastewater tank in Plant No. 2 was located within Reactor No. 2 along the northeast wall of the plant. It is not clear from facility records what other materials may have been stored in the AST. Facility documentation from 1987 indicates that the reactor is empty while documentation from 1996 indicates that distillate wastewater is stored in it. Due to the similarity of operations between plants, it was inferred that the wastewater was similar to that generated in Plant No. 1.
- **Flooring/Surface Type:** Based on the location within Plant No. 2, it is inferred that the AST was on a concrete surface.
- **Current Condition:** The tank has been removed. The concrete foundation remains in place. The adjacent walls have been demolished.

**SWMU/AOC 16: Reactor 4 Knockout Tank**



The reactor 4 knockout tank adjacent to Plant No. 2.

- **Timeframe of Operation:** Mid-1980s – 2002.
- **Material Handled and Type:** Polyurethane in solvent blend.
- **AOC Dimensions/Volumes of Materials/Tank Size:** One 2,000 gallon AST.
- **Brief Description:** Facility records from 1987 indicate that the 2,000-gallon AST was an emergency vent tank for Reactor 4 and was normally empty. Reactor 4 is listed as containing polyurethane in solvent blend, so these materials could have entered into the knockout tank. The AST did not appear on the 1982 facility drawing.
- **Flooring/ Surface Type:** Concrete with a small dike.
- **Current Condition:** The tank has been removed. The concrete pad is in place. The adjacent walls have been demolished.
-



---

**SWMU/AOC 17: Pump Overflow of Dimethylformamide (DMF)**

Area where the DMF pump overflowed.

- **Timeframe of Operation:** Unknown
- **Material Handled and Type:** Dimethylformamide.
- **AOC Dimensions/Volumes of Materials/Tank Size:** AOC dimensions are ill-defined based on the records review.
- **Brief Description:** Not available.
- **Flooring/Surface Type:** Concrete/asphalt.
- **Current Condition:** The concrete/asphalt surface is in place. The adjacent walls have been demolished.

**SWMU/AOC 18: Plant 2 Hexanediol Tank Transfer Station**

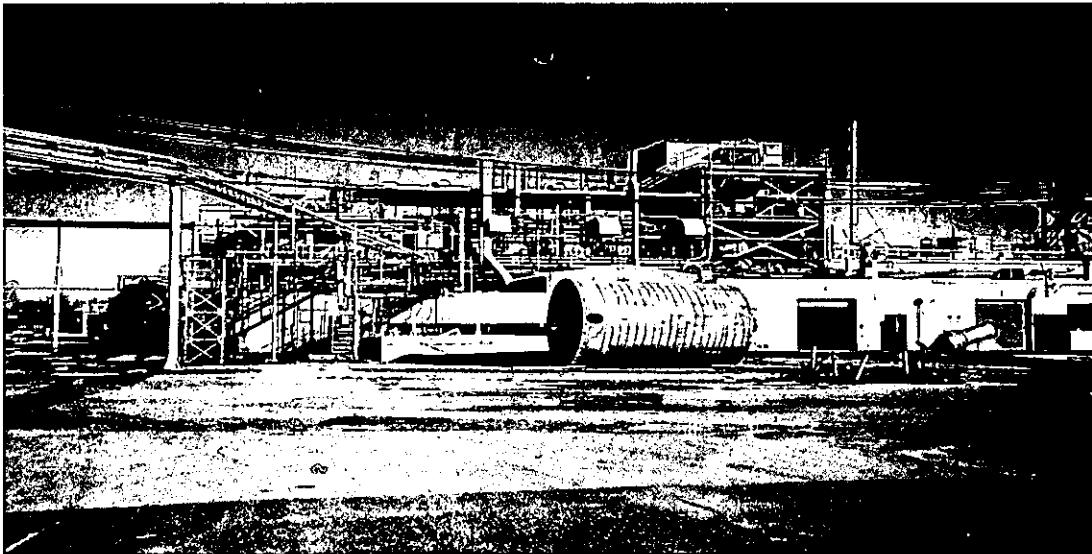

The hexanediol tank and transfer station.

- **Timeframe of Operation:** Late-1950s to 2002.
- **Material Handled and Type:**
  - 1968: Vinyl chloride
  - 1987: Polyurethane in inhibited styrene
  - 1996: Hexanediol
- **OC Dimensions/Volumes of Materials/Tank Size:**
  - 1968/1982: Two 5,000-gallon tanks
  - 1987/1996: One 12,000-gallon tank
- **Brief Description:** Documents from 1968 and 1982 indicate the presence of two 5,000-gallon tanks in this area. In 1968 the tanks were used to store vinyl chloride (pure and recycled). The tanks were reportedly empty in 1982. Facility records from 1987 and 1996 indicate the presence of a single 12,000-gallon tank. In 1987 the tank reportedly contained polyurethane in inhibited styrene; in 1996, the tank was used to store hexanediol.
- **Flooring/Surface Type:** Grass and gravel.
- **Current Condition:** The hexanediol tank, associated piping and diking has been removed.

**SWMU/AOC 19: Fume Incinerator**

The fume incinerator located along the northeastern wall of Plant No. 2.

- **Timeframe of Operation:** Late-1980s to 2002.
- **Material Handled and Type:** Gaseous by-products of production processes.
- **AOC Dimensions/Volumes of Materials/Tank Size:** Unknown.
- **Brief Description:** The incinerator was permitted under NYSDEC regulations (Permit to Operate an Air Pollution Source). Any releases from the incinerator would have been in the form of fumes and would have been to the atmosphere.
- **Flooring/Surface Type:** Concrete footer, grass and gravel.
- **Current Condition:** The fume incinerator has been removed and demolished. No waste remains. The adjacent walls have been demolished.

---

**SWMU/AOC 20: RCRA Less Than 90 Day Storage Unit**

View of a portion of the west side of the less than 90 day storage area.

- **Timeframe of Operation:** Mid-1980s to 2002.
- **Material Handled and Type:** Solid and liquid hazardous wastes.
- **AOC Dimensions/Volumes of Materials/Tank Size:** Approximately 18 feet by 24 feet.
- **Brief Description:** This less than 90 day storage area was located inside Plant No. 3, near the eastern corner of the building. Waste drums from the satellite accumulation areas were stored in 55-gallon drums. Drums containing hazardous wastes were staged in steel dike pans while in the area. Documentation from a RCRA inspection in 1984 indicated that approximately eight drums of hazardous materials were present in the area.
- **Flooring/ Surface Type:** Concrete.
- **Current Condition:** This SWMU/AOC was cleaned and closed in 2002/2003. No waste remains. The concrete foundation and cinder block walls are in place.

**SWMU/AOCs 21 A and B: Adipic Acid Silos -Transfer Stations**



Transfer station for adipic acid (AOC 21A).

- **Timeframe of Operation:** 1965 – 2002.
- **Material Handled and Type:** solid Adipic acid powder.
- **AOC Dimensions/Volumes of Materials/Tank size:** Five 4,500 cubic foot silos.
- **Brief description:** These transfer stations supported five 4,500 cubic foot silos (AOC 21B) which were located to the southeast of Plant No. 3. A review of facility documents indicated that the silos were used for adipic acid storage since they were installed in 1965. Facility records also suggest that no more than three of the silos were in use at any given time. The loading and unloading areas for the adipic acid silos (AOC 21A and 21 B) are located to the northeast and southwest of the silos.
- **Flooring/Surface type:** Asphalt, Concrete
- **Current Conditions:** The adipic acid silos have been cleaned and demolished. The transfer stations remain. The asphalt and concrete remain in place.

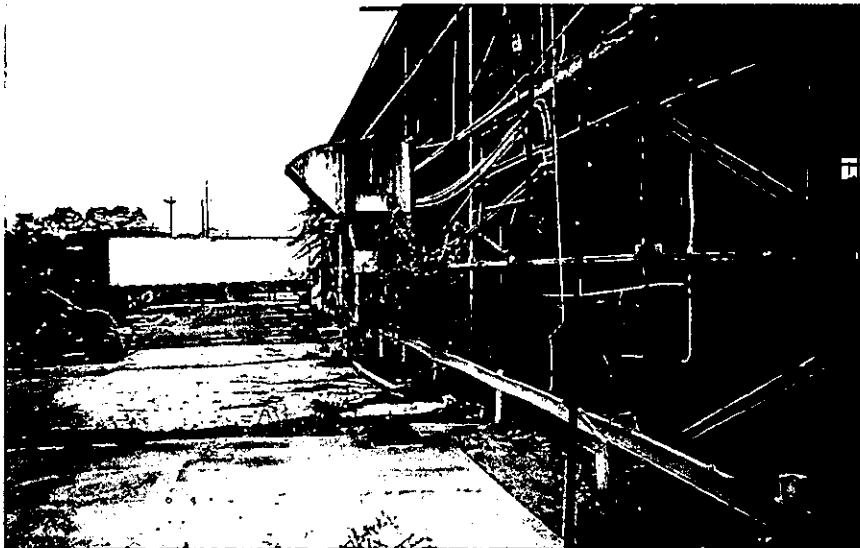
**SWMU/AOC 22: Tote Storage Area**

Tote storage area adjacent to Plant No. 3.  
A trailer storage area (AOC 27A) is shown in the background.

- **Timeframe of Operation:** Unknown.
- **Material Handled and Type:** Off-specification polyester reaction products and water.
- **AOC Dimensions/Volumes of Materials/Tank Size:** The number of 500-gallon totes is ill-defined based on the records review.
- **Brief Description:** Off-specification polyester reaction products and water that were to be reworked were stored in 500 gallon totes in this area.
- **Flooring/Surface Type:** Concrete and asphalt.
- **Current Conditions:** The totes have been removed, cleaned, and disposed. The concrete and asphalt remain.

---

**SWMU/AOC 23: Non-Hazardous Waste Accumulation Area, Plant 3**

NO PHOTOGRAPH AVAILABLE

- **Timeframe of Operation:** Unknown.
- **Material Handled and Type:** Non-hazardous off-spec products and raw materials.
- **AOC Dimensions/Volumes of Materials/Tank Size:** Unknown volume of material stored in area, AOC dimensions are ill-defined based on records review.
- **Brief Description:** This area was used to store mainly non-hazardous off-spec products and raw materials.
- **Flooring/Surface Type:** Concrete.
- **Current Conditions:** All of the wastes have been removed and disposed. The concrete foundation of Plant 3 remains. The pipe chase is still evident in the foundation.

**SWMU/AOC 24: Tank Farm and Transfer Station**

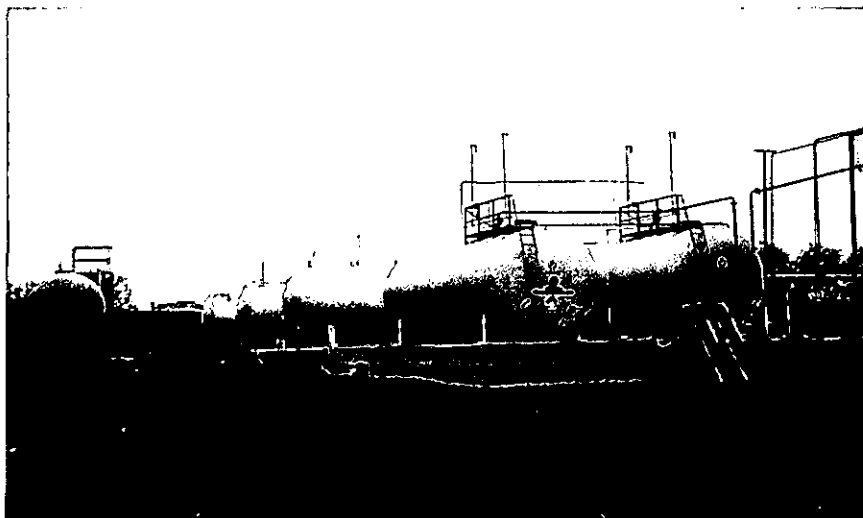

Some of the tanks in the tank farm.

- **Timeframe of Operation:** 1959 to 2002.
- **Material Handled and Type:** Based on facility documents, the following chemicals are known to have been stored in the tank farm:

Butadiene	Dimethylformamide	Isopropyl alcohol	Propylene glycol	Toluene
Diethylene glycol	Ethylene glycol	Methyl ethyl ketone	Styrene	Vinyl chloride

- **AOC Dimensions/Volumes of Materials/Tank Size:** Based on a review of facility documents, the tank sizes ranged from 6,500-gallons to 30,000-gallons, as detailed below.

Tank 31 – 30,000 gallons	Tank 33 – 25,000 gallons	Tank 35A – 8,000 gallons	Tank 36 – 15,000 gallons
Tank 32 – 25,000 gallons	Tank 34 – 10,000 gallons	Tank 35B – 6,500 gallons	

- **Brief Description:** This SWMU/AOC consists of the transfer station, the tank farm, the dispensing station, and the sump; the area of interest includes the tank farm and the area directly adjacent to the unloading area. Formerly, there were seven tanks located in the tank farm. Facility documents indicate that tanks were installed in this area in 1959.
- **Flooring/Surface Type:** ASTs were constructed of steel, the ground surface is covered with concrete.
- **Current Conditions:** As of October 15, 2002, the tanks had been emptied and inspected by the Nassau County Department of Health for closure. The tanks have been removed. The concrete bases remain, but the dike walls have been removed.



---

**SWMU/AOC 25: Former Soil Pile Area**

NO PHOTOGRAPH AVAILABLE

- **Timeframe of Operation:** 1988 – 2002.
- **Material Handled and Type:** Fuel oil- and PCB-contaminated soil.
- **AOC Dimensions/Volumes of Materials/Tank Size:** Unknown volume of soils stockpiled in area.
- **Brief Description:** Soil was stockpiled in this area after removal of the fuel oil UST that was removed from the southeast end of Plant No. 1 (AOC 10). The stockpiled soils were eventually removed and disposed off-site at a chemical waste landfill.
- **Flooring/Surface Type:** Soil/Grass

The area of the former stockpiled soil will not be investigated during this investigation since all soils formerly staged in this area were removed and disposed of off-site. The stockpiled soil was managed under the oversight of the Superfund program.

**SWMU/AOC 26: Historical Spills**

This AOC was deleted during the comments on the draft Work Plan.

Stained soil areas or areas where significant spills were known to have occurred have been identified, resulting in additional SWMUs being listed. These areas are associated with other SWMUs/AOCs and will be sampled in association with the completion of sampling at the listed SWMUs/AOCs.

---

**SWMU/AOC 27 A: Material Storage Area**

NO PHOTOGRAPH AVAILABLE

- **Timeframe of Operation:** Unknown.
- **Material Handled and Type:** Non-hazardous substances, off-specification product, spent product, damaged product, and/or raw materials.
- **AOC Dimensions/Volumes of Materials/Tank Size:** Unknown volume, AOC dimensions are ill-defined based on records review.
- **Brief Description:** It is known that non-hazardous substances, off-specification product, spent product, damaged product, and/or raw materials were stored here in drums and supersacks inside of truck trailers.
- **Flooring/ Surface Type:** Soil/Grass
- **Current Conditions:** All materials have been removed and no items are stored in this area.

---

**SWMU/AOC 27 B: Material Storage Area**

NO PHOTOGRAPH AVAILABLE

- **Timeframe of Operation:** Unknown.
- **Material Handled and Type:** Non-hazardous substances, off-specification product, spent product, damaged product, and/or raw materials.
- **AOC Dimensions/Volumes of Materials/Tank Size:** Unknown volume, AOC dimensions are ill-defined based on records review.
- **Brief Description:** It is known that non-hazardous substances, off-specification product, spent product, damaged product, and/or raw materials were stored in drums inside of truck trailers throughout the site; some exterior drum storage was also involved.
- **Flooring/ Surface Type:** Asphalt/Soil/Grass.
- **Current Conditions:** All materials have been removed and no items are stored in this area.

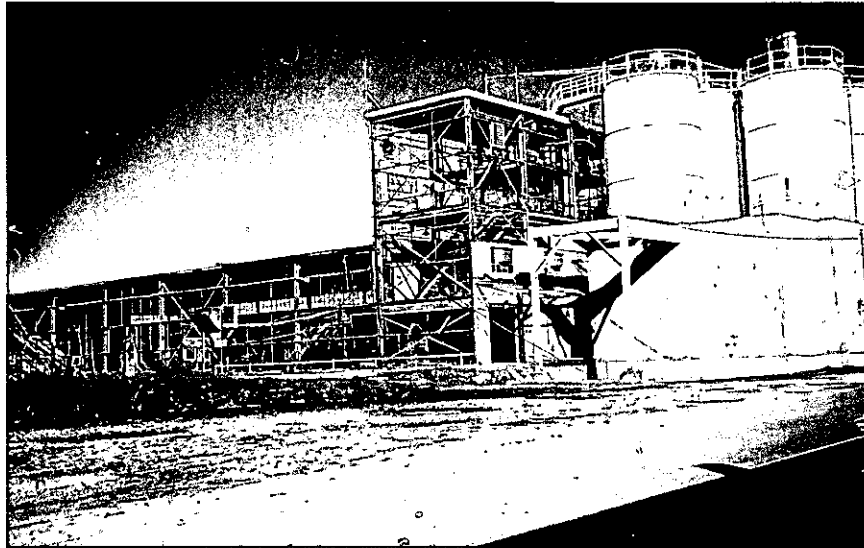
**SWMU/AOC 27 C: Material Storage Area**

- **Timeframe of Operation:** Unknown.
- **Material Handled and Type:** Non-hazardous substances, off-specification product, spent product, damaged product, and/or raw materials.
- **AOC Dimensions/Volumes of Materials/Tank Size:** Unknown volume, AOC dimensions are ill-defined based on records review.
- **Brief Description:** It is known that non-hazardous substances, off-specification product, spent product, damaged product, and/or raw materials were stored throughout the site in drums inside of truck trailers; some exterior drum storage was also involved.
- **Flooring/ Surface Type:** Asphalt/Soil/Grass.
- **Current Conditions:** All materials have been removed and no items are stored in this area.

---

**SWMU/AOC 27 D: Material Storage Area**

- **Material Handled and Type:** Bulk raw materials in rail car quantities.
- **AOC Dimensions/Volumes of Materials/Tank Size:** Up to two railcars were formerly stored in this area.
- **Brief Description:** It is known that non-hazardous substances, off-specification product, spent product, damaged product, and/or raw materials were stored in tank railcars in this area between Plant No.1 and the warehouse.
- **Flooring/Surface Type:** Gravel/Soil.
- **Current Conditions:** All materials have been removed and no items are stored in this area.

---

**SWMU/AOC 27 E: Material Storage Area**

NO PHOTOGRAPH AVAILABLE

- **Timeframe of Operation:** Unknown.
- **Material Handled and Type:** Non-hazardous substances, off-specification product, spent product, damaged product, and/or raw material.
- **AOC Dimensions/Volumes of Materials/Tank Size:** Unknown volume, AOC dimensions are ill-defined based on records review.
- **Brief Description:** It is known that non-hazardous substances, off-specification product, spent product, damaged product, and/or raw materials were stored throughout the site in drums inside of truck trailers; some exterior drum storage was also involved.
- **Flooring/Surface Type:** Asphalt and Soil
- **Current Conditions:** All materials have been removed and no items are stored in this area.

---

**SWMU/AOC 27 F: Material Storage Area**

NO PHOTOGRAPH AVAILABLE

- **Timeframe of Operation:** Unknown.
- **Material Handled and Type:** Non-hazardous substances, off-specification product, spent product, damaged product, and/or raw materials
- **AOC Dimensions/Volumes of Materials/Tank Size:** Unknown volume, AOC dimensions are ill-defined based on records review.
- **Brief Description:** It is known that non-hazardous substances, off-specification product, spent product, damaged product, and/or raw materials were stored in this area in up to two tank trailers.
- **Flooring/Surface Type:** Asphalt and soil
- **Current Conditions:** All materials have been removed and no items are stored in this area.

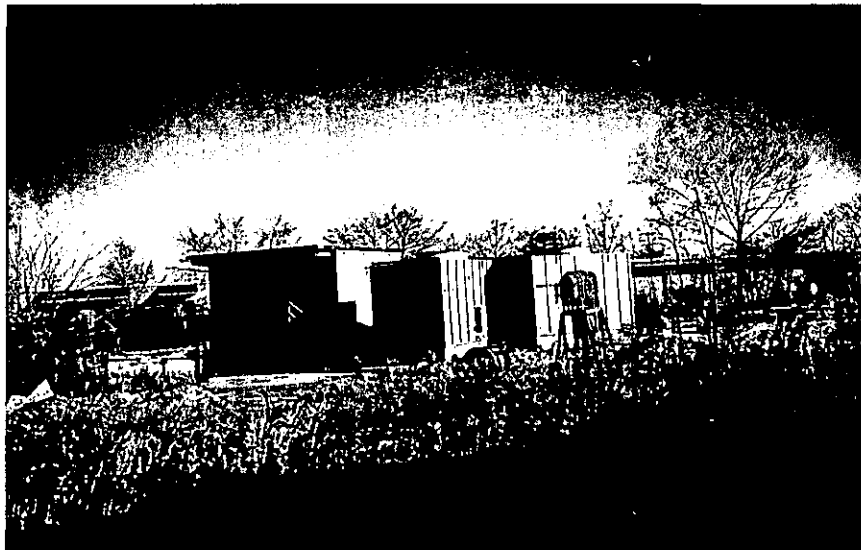

---

**SWMU/AOC 27 G: Material Storage Area**

Non-hazardous/off-spec/damaged product/raw material storage and the Cold Room.

- **Timeframe of Operation:** Unknown.
- **Material Handled and Type:** Non-hazardous substances, off-specification product, spent product, damaged product, and/or raw materials
- **AOC Dimensions/Volumes of Materials/Tank Size:** Unknown volume, AOC dimensions are ill-defined based on records review.
- **Brief Description:** It is known that non-hazardous substances, off-specification product, spent product, damaged product, and/or raw materials were stored throughout the site in drums inside of truck trailers; some exterior drum storage was also involved.
- **Flooring/ Surface Type:** Asphalt and soil.
- **Current Conditions:** All materials have been removed and no items are stored in this area.

---

**SWMU/AOC 27 H: Material Storage Area**

NO PHOTOGRAPH AVAILABLE

- **Timeframe of Operation:** Unknown.
- **Material Handled and Type:** Non-hazardous substances, off-specification product, spent product, damaged product, and/or raw materials
- **AOC Dimensions/Volumes of Materials/Tank Size:** Unknown volume, AOC dimensions are ill-defined based on records review.
- **Brief Description:** It is known that non-hazardous substances, off-specification product, spent product, damaged product, and/or raw materials were stored in drums inside of truck trailers; some exterior drum storage may also have been involved.
- **Flooring/Surface Type:** Asphalt and soil.
- **Current Conditions:** All materials have been removed and no items are stored in this area.

**SWMU/AOC 27 I: Material Storage Area**

- **Timeframe of Operation:** Unknown.
- **Material Handled and Type:** Non-hazardous substances, off-specification product, spent product, damaged product, and/or raw materials.
- **AOC Dimensions/Volumes of Materials/Tank Size:** Unknown volume; AOC dimensions are ill-defined based on record review.
- **Brief Description:** It is known that non-hazardous substances, off-specification product, spent product, damaged product, and/or raw materials were stored here inside of a single rail tank car.
- **Flooring/Surface Type:** Concrete/asphalt.
- **Current Conditions:** All materials have been removed and no items are stored in this area.

---

**SWMU/AOC 27 J: Material Storage Area**

NO PHOTOGRAPH AVAILABLE

- **Timeframe of Operation:** Unknown.
- **Material Handled and Type:** Non-hazardous substances, off-specification product, spent product, damaged product, and/or raw materials.
- **AOC Dimensions/Volumes of Materials/Tank size:** Unknown volume, dimensions of the AOC are ill-defined based on records review.
- **Brief description:** It is known that non-hazardous substances, off-specification product, spent product, damaged product, and/or raw materials were stored throughout the site in drums inside of truck trailers; some exterior drum storage was also involved.
- **Flooring/Surface Type:** Asphalt
- **Current Conditions:** All materials have been removed and no items are stored in this area.

---

**SWMU/AOC 28: Sump No. 1**

NO PHOTOGRAPH AVAILABLE

- **Timeframe of Operation:** Unknown - 1975.
- **Material Handled and Type:** Site wastewater including mixed glycols and alcohols, perchlorethylene, methanol, and organic acids (adipic, trimetallic, maleic, and phthalic).
- **AOC Dimensions/Volumes of Materials/Tank Size:** Unknown.
- **Brief Description:** The sump received wastewater from Plant No. 1 as well as site runoff. Any contamination of the Recharge Basin, Sump No. 1 has been addressed in the RI/FS conducted by HCPC/OCC and any required cleanup is being conducted by HCPC/OCC as part of the Superfund program. No further action is recommended.
- **Flooring/Surface Type:** Soil.
- **Current Conditions:** The sump is empty and is being remediated under the Superfund program.

---

**SWMU/AOC 29: Sump No. 2**

NO PHOTOGRAPH AVAILABLE

- **Timeframe of Operation:** Liquid wastewater streams up to 1975, storm water.
- **Material Handled and Type:** Site wastewaters and overflow from Sump 1. See materials above.
- **AOC Dimensions/Volumes of Materials/Tank Size:** Unknown.
- **Brief Description:** Any contamination of the Recharge Basin, Sump No. 2 has been addressed in the RI/FS conducted by HCPC/OCC and any required cleanup is being conducted by HCPC/OCC as part of the Superfund program. No further action is recommended.
- **Flooring/Surface Type:** Soil.
- **Current Conditions:** The sump is vegetated and is being remediated under the Superfund program.

---

**SWMU/AOC 30: Sump No. 3**

View of a portion of Sump #3

- **Timeframe of Operation:** Installed in 1968, still in use.
- **Material Handled and Type:** Non-contact cooling water, storm water.
- **AOC Dimensions/Volumes of Materials/Tank Size:** Unknown.
- **Brief Description:** Historical discharges to the sump included non-contact cooling water, cooling tower blowdown, and boiler blowdown. These discharges occurred between February 1982 and December 1983, when the facility was under the ownership of Ruco. The wastewater discharges to Sump No. 3 were diverted into to the Nassau County Sewer District in the fall of 1983. This sump continues to be the receiving area for storm water generated on site.
- **Flooring/Surface Type:** Soil.
- **Current Conditions:** This sump is open and partially vegetated.

---

**SWMU/AOC 31: Sump No. 4**

NO PHOTOGRAPH AVAILABLE

- **Timeframe of Operation:** Unknown start date, receives stormwater at the present time
- **Material Handled and Type:** Liquid wastewater streams up to 1975, stormwater and SPDES permitted discharge to April 3, 1998, only stormwater afterward.
- **AOC Dimensions/Volumes of Materials/Tank Size:** Unknown.
- **Brief Description:** Sumps 4 and 5 handled the wastewater stream overflow from Sump 6. Sump No. 4 received water for the SPDES discharge from the manufacturing facility until April 3, 1998. In 1998, discharge to the sump was discontinued and rerouted to the Nassau County Sewer District. The sump continues to receive stormwater.
- **Flooring/ Surface Type:** Soil.
- **Current Conditions:** This sump is open and partially vegetated.



---

**SWMU/AOC 32: Sump No. 5**

NO PHOTOGRAPH AVAILABLE

- **Timeframe of Operation:** Unknown start date, filled in between 1982 and 1984
- **Material Handled and Type:** Liquid wastewater streams up to 1975.
- **AOC Dimensions/Volumes of Materials/Tank Size:** Approximately 8,000 square feet and rectangular.
- **Brief Description:** Sumps 4 and 5 handled the wastewater stream overflow from Sump 6. Sump No. 5 is located north of the Recharge Basin, Sump No. 4, and was filled in with clean fill by RUCO between 1982 and 1984. Any contamination of the Recharge Basin, Sump No. 5 has been addressed in the RI/FS being conducted by HCPC/OCC and any required cleanup would be the responsibility of HCPC/OCC.
- **Flooring/ Surface Type:** Unknown, assumed earthen.

**Current Conditions:** This sump has been backfilled to grade. The former boundaries are unknown.

---

**SWMU/AOC 33: Sump No. 6**

NO PHOTOGRAPH AVAILABLE

- **Timeframe of Operation:** Unknown start date, filled in between 1982 and 1984
- **Material Handled and Type:** Liquid wastewater streams up to 1975.
- **AOC Dimensions/Volumes of Materials/Tank Size:** Approximately 5,000 square feet and square in shape.
- **Brief Description:** Sump No. 6 is located northeast of Plant 2 and west-northwest of the Recharge Basin, Sump No. 4 and was filled in by RUCO between 1982 and 1984. Any contamination of the Recharge Basin, Sump No. 6 has been addressed in the RI/FS being conducted by HCPC/OCC and any required cleanup would be the responsibility of HCPC/OCC.
- **Flooring/ Surface Type:** Earthen
- **Current Conditions:** This sump has been backfilled to grade. The former boundaries are unknown.

---

**SWMU/AOC 34: Cooling Tower Sump**

NO PHOTOGRAPH AVAILABLE

- **Timeframe of Operation:** Early 1960s to 2002
- **Material Handled and Type:** Cooling water with water treatment chemicals
- **AOC Dimensions/Volumes of Materials/Tank Size:** AOC Dimensions are ill-defined based on records review.
- **Brief Description:** The cooling tower sump was used for cooling water with water treatment chemicals. No wastes were disposed of to this sump.
- **Flooring/ Surface Type:** Unknown
- **Current Conditions:** The cooling tower has been removed. The sump and associated concrete remain in place.

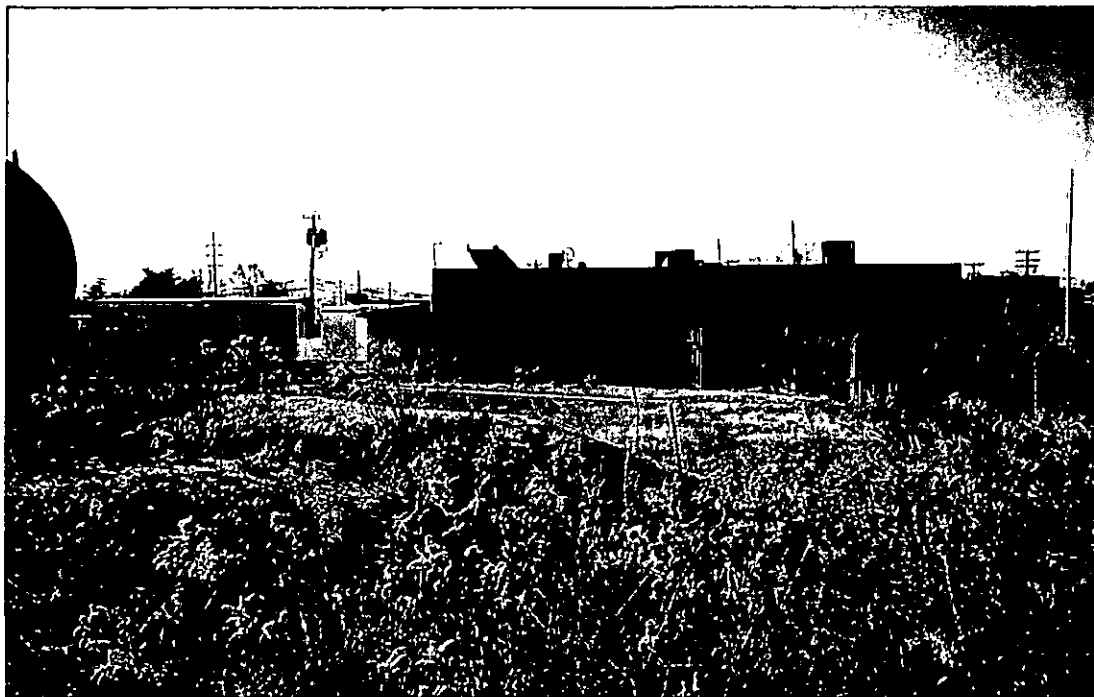
**SWMU/AOC 35A-G: Septic Tank/ French Drains/Cesspools in various locations**

View of surface above septic tank/french drains near Admin building (AOC 35A)

- **Timeframe of Operation:** Unknown start to the early 1980s.
- **Material Handled and Type:** liquid wastes and sanitary sewer
- **AOC Dimensions/Volumes of Materials/Tank Size:** Historical sanitary waste flows were estimated at 2,000 gallons per day in a document dated 1987.
- **Brief Description:** Since the manufacturing plant is over 60 years old, liquid wastes were disposed below grade prior to the facility connecting to the Nassau County Sewer District in the early 1980s. Historic drawings were investigated to determine the location of the disconnected discharges. These areas are identified on Figure 1-2 as areas 35A through 35G; additional detail on the proposed investigation is presented in Table 2-1.
- **Flooring/ Surface Type:** Not applicable.
- **Current Conditions:** These cesspools are no longer in use.

**SWMU/AOC 36: Administration Building Closed Laboratory Storage Area**

Photo of the closed laboratory storage area.

- **Timeframe of Operation:** Unknown time of operation.
- **Material Handled and Type:** Unknown
- **AOC Dimensions/Volumes of Materials/Tank Size:** AOC dimensions are ill-defined based on records review.
- **Brief Description:** Unknown
- **Flooring/ Surface Type:** Concrete pad
- **Current Conditions:** The area is no longer in use. No materials are stored in this area.

---

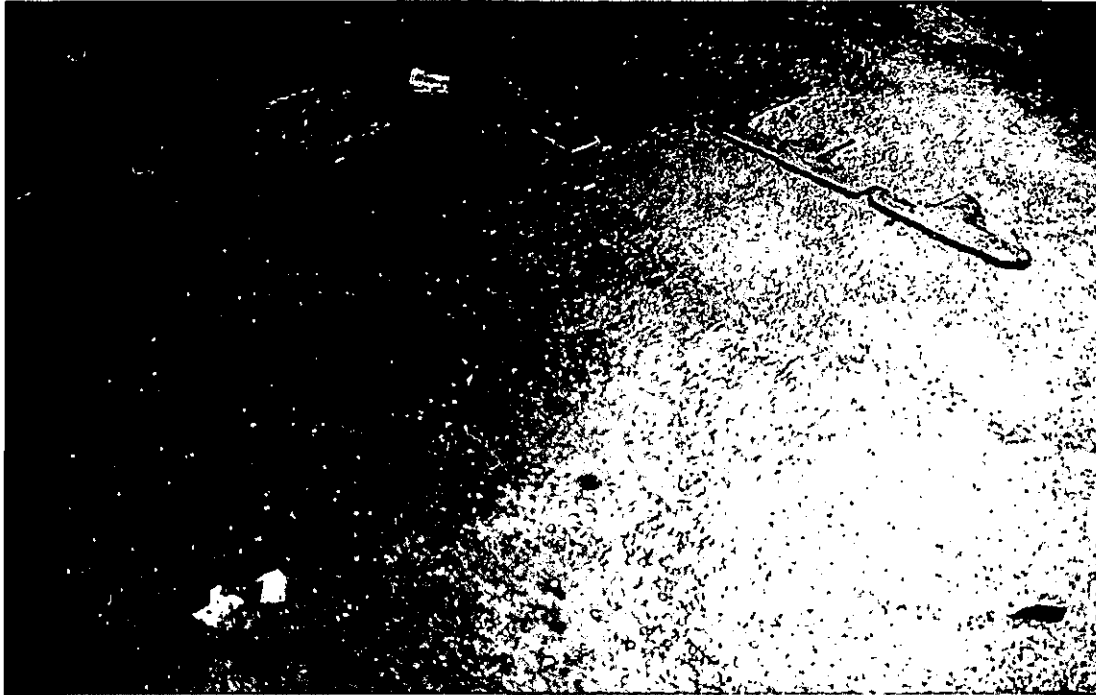
**SWMU/AOC 37: DOA Sump**

View of the DOA Sump in Plant 2.

- **Timeframe of Operation:** Unknown time of operation.
- **Material Handled and Type:** Unknown
- **AOC Dimensions/Volumes of Materials/Tank Size:** Unknown. This is a sump within the foundation of Plant 2.
- **Brief Description:** Unknown
- **Flooring/ Surface Type:** Concrete
- **Current Conditions:** The foundation in Plant 2 remains in place. The sump is no longer used.

---

**SWMU/AOC 38: Exterior Trench**

“Planter” trench behind Plant 2.

- ***Timeframe of Operation:*** Unknown time of operation.
- ***Material Handled and Type:*** Unknown
- ***AOC Dimensions/Volumes of Materials/Tank Size:*** Unknown
- ***Brief Description:*** Unknown
- ***Flooring/ Surface Type:*** Unknown

---

**SWMU/AOC 39: Electrical Transformers (former SWMU/AOC 8.1)**

Photo of former transformer location.

- **Timeframe of Operation:** Unknown installation date, removed from site in 2002/2003.
- **Material Handled and Type :** PCB fluid in transformers.
- **AOC Dimensions/Volumes of Materials/Tank Size:** AOC dimensions are ill-defined based on records review.
- **Brief Description:** The transformers have been removed from the Site. PCB contamination of the areas outside of the transformer area adjacent to Plant No. 1 were addressed in the RI/FS that was conducted by HCPC/OCC and the cleanup required in OU-2 was the responsibility of HCPC/OCC.
- **Flooring/ Surface Type:** Concrete
- **Current Conditions:** The transformers have been removed. The concrete pad is in place.



---

**SWMU/AOC 40: Trench System In Plant 3**

NO PHOTOGRAPH AVAILABLE

- **Timeframe of Operation:** Unknown.
- **Material Handled and Type:** Unknown.
- **AOC Dimensions/Volumes of Materials/Tank Size:** Unknown.
- **Brief Description:** These were the former pipe and electrical trenches within Plant 3. Most of the trenches appear to have been cemented in and/or covered.
- **Flooring/Surface Type:** Concrete.

---

**SWMU/AOC 41: Stained Concrete in Plant 1 Warehouse**

NO PHOTOGRAPH AVAILABLE

- ***Timeframe of Operation:*** Unknown.
- ***Material Handled and Type:*** Products and/or raw materials
- ***AOC Dimensions/Volumes of Materials/Tank Size:*** AOC dimensions are ill-defined based on records review.
- ***Brief Description:*** Stains from leakage of products and/or raw materials are present on the concrete floor of the warehouse. It is not known when the leakage occurred.
- ***Flooring/ Surface Type:*** Concrete
- ***Current Conditions:*** The concrete remains in place.

---

**SWMU/AOC 42: Plant 1 Trench**

View of the trench in Plant 1 foundation.

- **Timeframe of Operation:** Estimated time of operation is between 1955 and 1975.
- **Material Handled and Type:** Assumed to be similar to the wastewater discharged to Sump 1 (SWMU/AOC 28).
- **AOC Dimensions/Volumes of Materials/Tank Size:** Unknown
- **Brief Description:** Unknown
- **Flooring/ Surface Type:** Concrete.
- **Current Conditions:** The trench appears to be filled with concrete.

---

**SWMU/AOC 43: Unknown Sump at the northeast end of Plant 1**

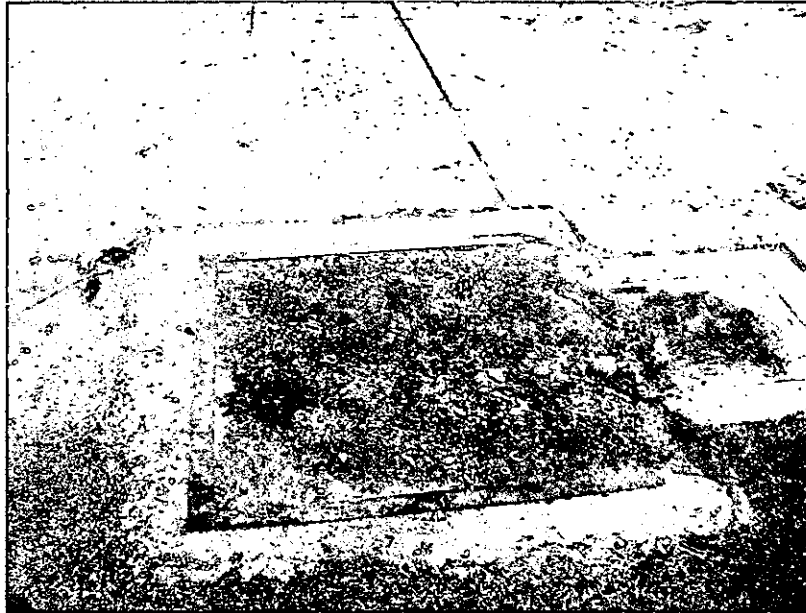

- ***Timeframe of Operation:*** Unknown time of operation.
- ***Material Handled and Type:*** Unknown
- ***AOC Dimensions/Volumes of Materials/Tank Size:*** Unknown
- ***Brief Description:*** Unknown
- ***Flooring/ Surface Type:*** Unknown

---

**SWMU/AOC 44: Unknown Sump at southeast end of Plant 1**

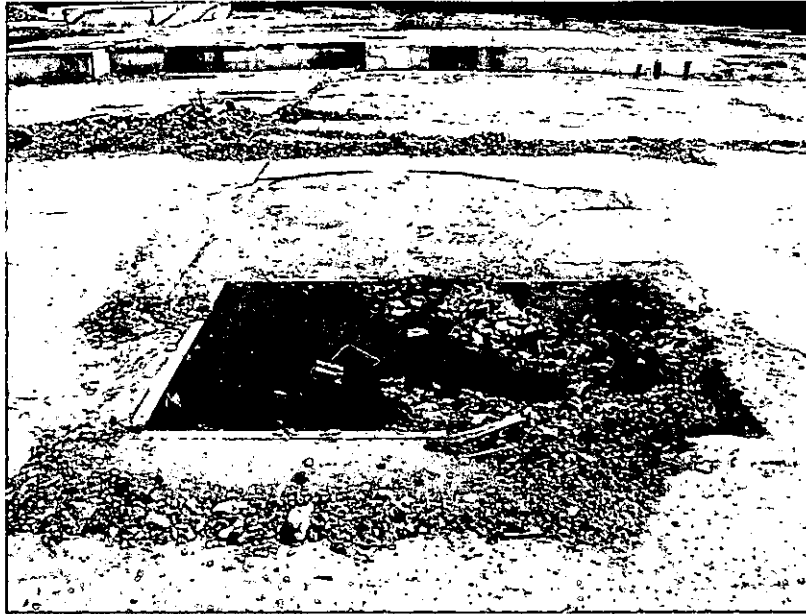

View of sump at southeast end of Plant 1.

- ***Timeframe of Operation:*** Unknown time of operation.
- ***Material Handled and Type:*** Unknown
- ***AOC Dimensions/Volumes of Materials/Tank Size:*** Unknown
- ***Brief Description:*** Unknown
- ***Flooring/ Surface Type:*** Unknown

---

**SWMU/AOC 45: Unknown Sump in the northwest corner of the Pilot Plant**

NO PHOTOGRAPH AVAILABLE

- ***Timeframe of Operation:*** Unknown time of operation.
- ***Material Handled and Type:*** Unknown
- ***AOC Dimensions/Volumes of Materials/Tank Size:*** Unknown
- ***Brief Description:*** Unknown
- ***Flooring/ Surface Type:*** Unknown

**SWMU/AOC 46: Scale and Circular Plate Areas**



The scale (below) and circular plate (above) areas in the foundation of Plant 2 will be investigated due to their unknown use.

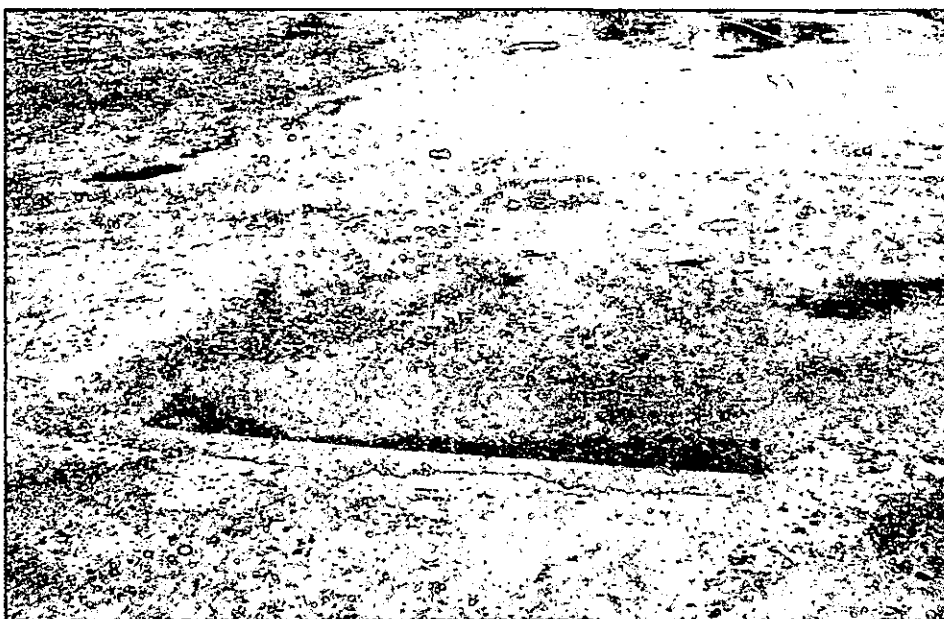

- ***Timeframe of Operation:*** Unknown
- ***Material Handled and Type:*** Unknown
- ***AOC Dimensions/Volumes of Materials/Tank Size:*** Unknown
- ***Brief Description:*** Unknown
- ***Flooring/ Surface Type:*** Unknown



---

**SWMU/AOC 47: Plant No. 2 Trench System and Sump discharging to Sump No. 4**

NO PHOTOGRAPH AVAILABLE

- **Timeframe of Operation:** The trench, sump, and piping to Sump No. 4 are shown on facility drawings from 1955.
- **Material Handled and Type:** Wastewater associated with the processes occurring in Plant No. 2.
- **AOC Dimensions/Volumes of Materials/Tank Size:** The trench runs approximately 100 feet from the northwestern wall of Plant No. 2 to the sump located along the northeastern wall. Piping connects the sump with the Recharge Basin via Sump No. 4.
- **Brief Description:** Trench system located in foundation of the northern portion of Plant No. 2. The trench system formerly transmitted wastes to the sump and from there to Sump No. 4 in the Recharge Basin.
- **Flooring/Surface Type:** Concrete.

---

**SWMU/AOC 48: Empty Drum Storage, exterior Plant 1 warehouse**

NO PHOTOGRAPH AVAILABLE

- ***Timeframe of Operation:*** Unknown
- ***Material Handled and Type:*** Unknown
- ***AOC Dimensions/Volumes of Materials/Tank Size:*** AOC Dimensions are ill-defined based on records review.
- ***Brief Description:*** The presence of empty drums was observed in this area.
- ***Flooring/ Surface Type:*** Asphalt

---

**SWMU/AOC 49: Trench around the east wall of the Pilot Plant**

NO PHOTOGRAPH AVAILABLE

- ***Timeframe of Operation:*** Unknown time of operation.
- ***Material Handled and Type:*** Unknown
- ***AOC Dimensions/Volumes of Materials/Tank Size:*** Unknown
- ***Brief Description:*** Unknown
- ***Flooring/ Surface Type:*** Unknown

### 3.0 WASTE CHARACTERISTICS

As previously discussed, the Site has been used since the early 1950s for the production of rubber latex and PVC compounds, PVC film and sheet, plasticizers and polyesters, and polyvinyl chloride resin. The production of plastics can involve the use of chemical additives to modify the characteristics of the plastic resins. There are several types of chemicals which can be added to plastics to modify their characteristics.

- Antioxidants inhibit the oxidation of plastic materials that are exposed to oxygen. These chemicals include alkylated phenols, amines, organic phosphates and phosphates, and esters.
- Antistats prevent electrostatic charge accumulation on the finished plastic product by imparting electrical conductivity to the plastic compound. These chemicals include quaternary ammonium compounds, anionics, and amines.
- Plasticizers increase the plastic's flexibility and workability. These chemicals include adipates, azelates, trimetallites, and di(2-ethylhexyl)phthalate/diisooctyl phthalate/diisodecyl phthalate.

These and other types of chemicals were historically used at the Site. These chemicals can generally be divided into several broad classes:

- Organic Acids
- Inorganic Acids
- Alkalies
- Amines
- Catalysts
- Glycols
- Isocyanates
- Metallic Compounds
- Organic Oils
- Plasticizers
- Oxidizers
- Phenols
- Aqueous Polymer Emulsions
- Resins
- Solvents
- Surfactants
- Water Treatment Chemicals
- Other Chemicals

The characteristics of these classes of chemicals are provided below.

Releases of these materials during the plastics manufacturing process can include spills, leaks, and fugitive emissions of raw materials; wastewater discharges; plastic pellet releases to the environment

prior to molding; and fugitive emissions from molding and extruding machines. The intent of this section is to briefly present the physical nature of the materials used during production, and present their potential environmental migration methods based on the physical characteristics. For several of the materials used at the Site limited information is available, due to the termination of operations at the Site.

### **3.1 Chemical Information**

#### **3.1.1 Organic Acids**

All organic acids contain the carboxyl group (-COOH). Acids with one carboxyl group are known as *monocarboxylic acids* and those with more than one are *polycarboxylic acids*. Organic acids represent the highest oxidation state an organic chemical can attain; further oxidation results in the formation of carbon dioxide and water, at which time the organic acid is considered completely destroyed.

Organic acids known to have been stored at the Site include adipic acid, azelaic acid, isophthalic acid, maleic anhydride, methane sulfonic acid, phthalic anhydride, terephthalic acid, toluene sulfonic acid, and trimetallic anhydride. Adipic acid was frequently used at the Site. These compounds are generally available in solid form. The organic acids range in solubility from insoluble (terephthalic acid) to highly soluble (azelaic acid).

If spilled under dry conditions, the organic acids would be released to soil and migrate primarily via wind. Soluble compounds could dissolve during precipitation events and potentially migrate to groundwater. Many of these compounds are readily biodegradable.

#### **3.1.2 Inorganic Acids**

Inorganic acids known to have been stored at the Site include phosphoric acid and sulfuric acid. Both compounds are corrosive liquids with a density greater than that of water. These acids are hygroscopic (i.e., absorb moisture from the atmosphere) and miscible in water.

If spilled, these liquid inorganic acids would be released to soil and migrate through the soil column to groundwater. Due to the acidic nature of these compounds, if released they could alter the geochemistry of the soil column and leach metals to groundwater.

#### **3.1.3 Alkalies**

Alkalies (also known as bases) are corrosive, caustic substances that dissociate in water and yield hydroxyl ions (OH<sup>-</sup>). Alkalies are not flammable and will not support combustion. However,

substantial heat can be generated when solid alkalis are dissolved in water. Alkalies may cause irritation of the eyes and respiratory tract and can cause severe burns.

Specific alkalies known to have been stored at the Site are aqueous ammonium hydroxide and anhydrous sodium hydroxide. Aqueous ammonium hydroxide is a liquid which is soluble in water and has a density lower than that of water. It has a strong, pungent ammonia odor detectable at relatively low levels and is considered an irritant that can cause tearing. Sodium hydroxide is a colorless, odorless solid that is highly soluble in water and has a density approximately twice that of water. This compound is hygroscopic.

If spilled, these compounds would be released to soil. The aqueous ammonium hydroxide could migrate through the soil column to groundwater. The sodium hydroxide would migrate primarily via wind, but could migrate to groundwater during precipitation events. Due to the basic nature of these compounds, they compounds may change the geochemistry of the soil column and leach metals to groundwater.

#### **3.1.4 Amines**

Amines are simple aliphatic compounds containing nitrogen. These compounds are ammonia derivatives with one or more alkyl groups attached. There are three types of amines, primary, secondary, and tertiary. These correspond to the number of hydrogen atoms that have been replaced by alkyl groups. Amines are basic, with the basicity increasing from primary to tertiary amines. Tertiary amines can combine with alkyl halides to form quaternary ammonium salts.

Specific amines known to have been stored at the Site include aminomethyl propanol, butylamine, diethylamine, hexamethylenediamine, isophoronediamine, Jeffamine® (polyoxyalkylamine), triethylamine, and Diazabicyclo (2.2.2) octane (DABCO). These compounds are generally available in both solid and liquid forms, depending on the compound. Many of the amines are water soluble to miscible.

If spilled, these compounds would be released to soil. Amines stored in solid form would migrate via wind while those in liquid form would migrate through the soil column to groundwater. Solid amines could migrate to groundwater during precipitation events. Free phase liquid amines would be expected to float on the water table as a light non-aqueous phase liquid (LNAPL) because they generally have densities lower than that of water.

### 3.1.5 Catalysts

Catalysts are substances that are used in the production of plastics products which increase the rate of chemical reaction. Several different catalysts have been used at the Site. Some of the catalysts include Cycat 600 (Ruco Catalyst 36), Fascat 2000 series catalysts, Fascat 4000 series catalysts, Fomrez, and tetraisopropyl titanate.

- Fascat 2000 series catalysts are stannous tin-based products that are primarily used in the manufacture of plasticizers and fatty acid esters. These catalysts are insoluble in water.
- Fascat 4000 series catalysts are organotin-based products that are used as transesterification catalysts for alkyd, polyester, and urethane coatings and resins. They are slightly soluble in water.
- Fomrez® UL-1 is a polyester polyol.
- Tetraisopropyl titanate is a transparent yellow liquid that is mainly used as a catalyst for the preparations of plasticizer and polyester. This compound is highly moisture sensitive.

If spilled, these compounds would be released to soil. Solid catalysts would migrate via wind while those in liquid form would migrate through the soil column to groundwater. Some of the solid catalysts could migrate to groundwater during precipitation events.

### 3.1.6 Glycols

Glycols are aliphatic dihydric alcohols. These compounds can be classified as primary, secondary, or tertiary, depending on the C-O-H groupings attached. These compounds are generally liquids that are readily soluble to miscible in water.

Glycols known to have been stored at the Site include 1,4-butanediol, 1,3-butylene glycol, Carbomax 400, cyclohex dimethanol, diethylene glycol, ethylene glycol, glycerine, glycol blends, 1,6-hexanediol, neopenyl glycol, NDG-90, propylene glycol, and trimethylol propane. The glycols stored at the Site have densities generally equivalent to or greater than that of water and are hygroscopic.

If spilled, these compounds would be released to soil and would migrate through the soil column to groundwater. Those glycols with densities greater than that of water would be expected to sink within the aquifer as DNAPLs.

### **3.1.7 Isocyanates**

Isocyanates are compounds containing one or more  $-N=C=O$  groups. Isocyanates react with compounds containing hydroxyl groups to produce polyurethane polymers.

Specific isocyanates known to have been stored at the Site include Desmodur W, diphenylmethane diisocyanate, toluene diisocyanate, and isophorone diisocyanate.

The isocyanates stored at the Site have densities generally greater than that of water and are insoluble to slightly soluble in water. Isocyanates are generally available in either solid or liquid form, depending on the specific compound (toluene diisocyanate is a liquid while diphenylmethane diisocyanate is a solid).

If spilled, these compounds would be released to soil. Those isocyanates in solid form would migrate primarily via wind; although during precipitation events the more soluble isocyanates could migrate to groundwater. Liquid isocyanates could migrate through the soil column to groundwater. The isocyanates would typically react with contact with moisture, either slowly or violently. They generally would react after contact with water and would not be a free product.

### **3.1.8 Metallic Compounds**

Aluminum Paste, Copper Sulfate, Martin Picard M-series compounds, Vinazene, and vanadium compounds were used at the Site. Limited information was available regarding Vinazene and the Martin Picard M-series compounds.

The aluminum paste and copper sulfate are generally available in solid form. Copper sulfate is hygroscopic and highly soluble in water. Vinazene is a cyanide-based monomer.

If spilled, these compounds would be released to soil. Those solid materials would migrate primarily via wind; although during precipitation events the more soluble compounds could migrate to groundwater. Liquid materials could also migrate through the soil column to groundwater.

### **3.1.9 Organic Oils**

Organic oils known to have been stored at the Site include Anderol and Therminol. Anderol is a synthetic lubricant. Therminol is a high temperature heat transfer fluid developed specifically for the indirect transfer of process heat. Therminol is also one of the trade names under which PCBs were sold. The chemical properties of these materials depend on the actual formulation used. Both oils



have over 20 commercially available formulations. It is not known which formulation(s) were stored at the Site.

### **3.1.10 Plasticizers**

Plasticizers known to have been stored at the Site include bis(2-ethylhexyl)phthalate (di(2-ethylhexyl)phthalate), dibutyl phthalate, and dibasic esters.

These compounds are generally colorless oily liquids with densities approximately equivalent to or greater than that of water. Plasticizers are generally insoluble to slightly soluble. They have a tendency to adhere to soil. They are generally biodegradable.

If spilled, these compounds would be released to soil and migrate through the soil column to groundwater. The phthalates have a tendency to adhere to soil; as such, these compounds may be attenuated before they reach groundwater. Free phase liquids would be classified as DNAPLs if the density is higher than that of water. Since these compounds are typically insoluble to slightly soluble, they would remain in NAPL form, slowly leaching constituents to groundwater.

### **3.1.11 Oxidizers**

Oxidizers known to have been stored at the Site were calcium hypochlorite and hydrogen peroxide (75% solution).

Calcium hypochlorite is generally available as a solid and is air sensitive and decomposes in water. Hydrogen peroxide is generally available as a liquid and is a strongly oxidizing material.

If spilled, these compounds would be released to soil. The calcium hypochlorite would primarily migrate via wind while the hydrogen peroxide would migrate through the soil column to groundwater.

### **3.1.12 Phenols**

Phenols known to have been stored at the Site were p-benzoquinone, bisphenol A, butylated hydrotoluene (BHT), tert-butylcatechol, hydroquinone, Irganox 1010, and Irganox 1035. Some of these compounds (e.g., Irganox) are used as antioxidants.

These compounds are available at the Site in solid form. They have densities generally greater than that of water and are slightly soluble to soluble in water.

If spilled, these compounds would be released to soil and primarily transported via wind. During precipitation events, the more soluble materials could migrate through the soil column to groundwater.

### **3.1.13 Aqueous Polymer Emulsions**

Aqueous polymer emulsions known to have been stored at the Site were Acrysol ASE-75, Cymel 370 Resin, and Rhoplex E-358.

Acrysol is an acrylic emulsion; Cymel 370 is a water-based cross-linking agent for hydroxyl and amide-containing polymers; this material is partly soluble in water. Rhoplex E-358 is a self-crosslinking acrylic emulsion. Cymel 370 is partly soluble in water; the solubilities of Acrysol and Rhoplex are not available.

These materials are generally available at the Site in liquid form. If spilled, these compounds would be released to soil and migrate through the soil column to groundwater.

### **3.1.14 Resins**

Resins specifically known to have been stored at the Site were polyvinyl alcohol and Firestone 4444R (PVC). In addition, resins were the principal products of the facility.

Polyvinyl alcohol consists of white to cream-colored granules or powder. It is a water-soluble synthetic polymer which can be used as a protective colloid in emulsion polymerization processes. It is a white-to cream-colored solid in granular or powder form with a density slightly higher than that of water. Information on Firestone 4444R was not available.

If spilled, the polyvinyl alcohol would be released to surface soils and migration would primarily occur via wind. During precipitation events, it could dissolve and migrate through the soil column to groundwater.

### **3.1.15 Solvents**

Solvents specifically known to have been stored at the Site include butyl cellosolve, cellosolve acetate, dimethylformamide, ethyl acetate, isopropyl alcohol, methyl cellosolve, methylene chloride, methyl ethyl ketone, methyl isoamyl ketone, methyl isobutyl ketone, PM acetate, n-propyl alcohol, prop glycol monomethyl ether, styrene, tetrahydrofuran, toluene, turpentine, and xylenes.

These compounds have a wide range of properties. Some are slightly soluble in water while others are miscible in water. Density also ranges from below that of water to above that of water. These compounds are generally available in liquid form.

If spilled, these materials would be released to soil. Most of the materials are VOCs and can evaporate if spilled. Most of the solvents were stored in liquid form; as such, they would migrate through the soil column to groundwater. Free phase liquid solvents would either be classified as LNAPLs if the density is lower than that of water or dense non-aqueous phase liquids (DNAPLs) if the density is higher than that of water. Those compounds that are miscible in water would be expected to dissolve more readily than those that are only slightly soluble.

### **3.1.16 Surfactants**

Surfactants known to have been stored at the Site include tetrasodium pyrophosphate, Alcasan QNA, Triton® X-405, and Tween 20. Most of these compounds are proprietary formulations with limited information available.

Tetrasodium pyrophosphate is a colorless or transparent solid in crystal or powder form. The Tween 20 and Triton® X-405 surfactants are liquids which, if spilled, could migrate through the soil column to groundwater. Both chemicals are miscible in water and have densities slightly above that of water. These surfactants could impact the migration and dispersion characteristics of other organic constituents by mobilizing compounds adhered to soils into groundwater.

### **3.1.17 Water Treatment Chemicals**

Water treatment chemicals known to have been stored at the Site include calcium hypochlorite, copper sulfate, Bond #24P (contains sodium hydroxide), Bond #33L (contains diethyl amino ethanol), Bond #47LX contains sodium salts of nitrilotriacetic and hexametaphosphate), Bond #96L6 (contains hydrazine and sulfite), Bond #96L8, Bond #96LS (contains sodium silicate) , and Bond #329L (contains poly-acrylate polymer) . Additional information about these materials was not available.

### **3.1.18 Other Chemicals**

Other chemicals known to have been stored at the Site include 2-butanone oxine, gasoline, diesel fuel, caprolactam, Stabaxol 1, Stabaxol M, Pyrol FR2, triphenyl phosphite (TPP), and tris-2- hydroxyethyl isocyanurate (THEIC).

Tris-2- hydroxyethyl isocyanurate and triphenyl phosphite are generally available on-site in solid form. Tris-2- hydroxyethyl isocyanurate) is a white crystalline powder that is soluble in water. It is a chemical intermediate that is used in the production of other chemicals, including polyesters and urethanes. Triphenyl phosphite is a colorless solid.

Most of the remaining chemicals are generally available on-site in liquid form. If spilled, the liquid chemicals would migrate through the soil column to groundwater. The solid chemicals would be released to soils and migrate primarily via wind. If soluble, these chemicals could migrate to groundwater during precipitation events.

### **3.2 Analytical Strategy**

Some of the materials known to have been used and/or stored at the Site are included on standard environmental analysis lists for VOCs or semi-volatile organic compounds (SVOCs) (e.g., bis(2-ethylhexyl)phthalate, toluene, methyl ethyl ketone, etc.). However, many of the materials historically stored on-site are not on the standard environmental analysis lists. In order to attempt to identify potential releases of these materials, a library search will be employed for both the VOC and SVOC scans to identify compounds that are not on the standard scans. Those compounds identified as part of the library search will be classified as TICs and the concentration will be considered an estimated value. The top 20 TICs will be included. In addition, where SVOCs will be analyzed, Method 8015 will also be requested in order to quantify concentrations of glycols.

The standard Target Analyte List of metals (aluminum, antimony, arsenic, barium, beryllium, cadmium, calcium, chromium, cobalt, copper, iron, lead, magnesium, manganese, mercury, nickel, potassium, selenium, silver, sodium, thallium, vanadium, zinc and cyanide) will be used. Due to the number of acidic and basic materials stored at the Site, soil pH will also be evaluated as an indicator for potential releases of these materials.

## 4.0 WORK PLAN

The project objectives are to evaluate environmental conditions of soil, sediment, and concrete surfaces at identified SWMUs/AOCs. The data collected during the RFA/RFI will be used for evaluating the need for further investigation, feasibility study, and risk evaluation purposes. Per prior agreements with the NYSDEC, RFA/RFI field activities will be conducted in accordance with the existing health and safety plans for the Site which have been previously submitted to the NYSDEC. For convenience, a copy of the Site Health and Safety Plan has been included as Appendix C.

### 4.1 Data Quality Objectives

The design of the RFA/RFI was based on the data quality objectives (DQO) process, a multi-step, iterative process that ensures that the type, quantity, and quality of environmental data used in decision making is appropriate for its intended application. Therefore, the sampling and analysis program has been based on:

- A sampling protocol designed to obtain sufficient data to evaluate the environmental conditions of the media of interest in the investigation areas;
- The use of sample collection and handling procedures that will ensure the representativeness and integrity of the samples; and
- An analytical program designed to generate definitive data of sufficient quality and sensitivity to meet the project objectives. Comprehensive data deliverables will allow validation of the data and reproduction of the reported results.

The study boundaries are limited to those AOCs related to Ruco/Bayer activities at the facility. AOCs which are included in HCPC/OCC investigation and remediation activities are excluded from this RFA/RFI.

If concentrations of constituents of interest are detected in surface soil, sediment, and concrete, the data will be compared to appropriate standards, criteria, and/or guidance values (SCGs). Results that exceed one or more SCGs may warrant further action.

The data will be considered acceptable if they are collected according to the RFA/RFI Work Plan and meet the appropriate data validation criteria.

These sampling activities included in this RFA/RFI Work Plan were designed to achieve the objectives discussed above. However, optimization of study design may be an iterative process. Field conditions

encountered during the RFA/RFI may entail changes to the proposed scope (e.g., relocation of sampling points). Reasons for changes to the proposed scope will be documented.

Information that will be used to evaluate environmental conditions include:

- Sample collection records and analytical results for soil, sediment, and concrete samples,
- Field measurements (e.g., soil VOC headspace), and
- Sample locations.

## **4.2 Sampling Strategy**

ENSR utilized available characterization data and recent and historical operational information as guidance in development of this RFA/RFI Work Plan. Where possible, a biased sampling approach will be utilized to supplement existing characterization data. For those portions of the Site where little to no data exists, a more non-biased/random sampling approach will be utilized.

Table 2-1 identifies each of the identified 48 SWMUs/AOCs that will be investigated to assess Site environmental conditions. When possible, existing information will be used to supplement the investigation.

### **4.2.1 Biased Sampling**

Many of the proposed sample locations were selected based on known past Site use. Key parameters used to focus the investigation included:

- Former waste handling/storage areas
- Former spill areas
- Former storage tank locations
- Former sewer lines and septic systems
- Former transformer areas
- Historic and recent plant operations

A number of known issues are being addressed by HCPC/OCC. The proposed investigation program takes into account the ongoing efforts for these areas, and was developed to address the remaining areas of concern. Table 2-1 also provides general sample locations selected based on one or more of

the key parameters identified above, the number and type of samples to be collected, the analyses to be performed, and the sample collection rationale.

#### **4.2.2 Non-Biased Sampling**

Areas of the facility where little to no data exist will be sampled using a more random approach. Sampling locations will be selected to provide areal coverage. Non-biased sampling will primarily be completed via soil samples collected through building slabs. Table 2-1 identifies the sample locations selected to provide areal coverage, along with the additional information described above.

#### **4.3 Field Sampling Techniques**

This section contains a brief description of the sampling and analyses techniques to be utilized to perform the RFA/RFI. The following media will be sampled and analyzed:

- Surface soil
- Subsurface soil
- Sediment
- Concrete
- Surface water

The proposed sampling locations are shown on Figures 2-1 through 2-10. The final locations for the sampling locations may be adjusted in the field based on access and utility clearance.

The media will be sampled and analyzed and then a corrective action plan will be developed for areas with elevated analytical detection limits. The estimated number of samples to be collected at each of the SWMU areas is identified in Table 4-1.

Quality Assurance/Quality Control (QA/QC) samples will be collected to ensure the data are accurate and meet the data quality objectives. Equipment rinsate blank, field blank, trip blank, method blank, and matrix spike samples will be collected and analyzed to assess the accuracy of the data resulting from the field sampling and analytical programs. The number and type of QA/QC samples to be collected for each media of interest are summarized in Table 4-1. ENSR's Standard Operating Procedures for various sampling methods and decontamination have been included as Appendix D.

### 4.3.1 Soil Investigation

Surface soil samples will be collected primarily using hand tools. Subsurface soil samples will be collected using direct-push technology (i.e., Geoprobe™). In areas where both surface and subsurface soil samples will be collected, the subsurface sampling methods will be used for all sample collection. In each sampling location undisturbed soil will be sampled. The focus of the soil investigation will be near surface soils in select AOCs; as such, soil borings will not exceed six feet in depth.

Soil samples that are to be taken beneath concrete slabs or asphalt pavement will have an approximately 2-inch diameter hole penetrated through the concrete with an air-hammer rock drill prior to sampling.

#### 4.3.1.1 Surface Soil Sampling Procedures

ENSR standard operating procedure (SOP) 7110 (Surface Soil Sampling) describes the methods for obtaining surface soil samples for chemical and physical analyses. Sampling equipment will consist primarily of shovels, trowels, and hand augers. Shovels will be used for loosening compacted soils or removing large rocks at the ground surface. Hand augers will be used to advance to the prescribed sample depth and to extract a sample. Hand trowels will be used to collect the sample from the auger and transfer it to the appropriate sampling jar.

Cuttings from the surface soil sampling program will be inspected for signs of contamination and screened with a photoionization detector (PID) equipped with a 10.6 eV lamp at the time of sample collection to detect for the presence of volatiles. Samples will be classified using the ASTM-D2488-84 "Standard Practice for Description and Identification of Soils (Visual-Manual Procedure). Field observations will be recorded in a field logbook (Section 4.3.4). Soil samples submitted for analysis will be collected from the soil interval with the highest PID reading, or other visual or olfactory evidence of impacts. The VOC sample will be collected directly from a one to two foot interval with the highest PID reading, or other visual or olfactory evidence of impacts. The remaining portions of the one to two-foot interval will be homogenized in stainless steel collection containers before being placed into sample containers for submission to the laboratory for analysis. Any remaining soil beyond what is necessary to fill the sample and quality control bottles will be returned to the sample location.

#### 4.3.1.2 Soil Borings Using a Geoprobe

ENSR SOP 7116 (Subsurface Soil Sampling by Geoprobe Methods) describes the methods for obtaining subsurface soil samples for analyses using direct push technology. ENSR proposes installing soil borings at specific areas on the Site as summarized in Table 2-1. In addition, Geoprobe samples will be collected under the building slabs at the same locations as the concrete core samples.



Geoprobe soil sampling techniques will involve driving a four-foot long hollow steel sampling tube into the subsurface using a hydraulic hammer. The sampling tubes will be fitted with dedicated acetate plastic liners for soil retention. Soil samples will be collected at varying depths based on the specific area investigated.

Cuttings from the subsurface soil sampling program will be inspected for signs of contamination and screened with a PID equipped with a 10.6 eV lamp at the time of sample collection to detect for the presence of volatiles. Samples will be classified using the ASTM-D2488-84 "Standard Practice for Description and Identification of Soils (Visual-Manual Procedure)". Field observations will be recorded in a field logbook (Section 4.3.4). Any remaining soil beyond what is necessary to fill the sample and quality control bottles will be returned to the sample location.

#### **4.3.2 Sediment Investigation**

A sediment investigation will be conducted to characterize conditions in several sumps, floor trenches, and drains. Figures 2-3, 2-5, 2-6, 2-7, 2-8, 2-9 and 2-11 show the approximate sediment sampling locations. Sediment samples from the sumps will consist of grab samples collected from the base of the sump.

#### **4.3.3 Concrete Surfaces Investigation**

A limited number of concrete samples from each building slab will be collected in order to characterize the concrete for either disposal and/or re-use. Concrete samples collected will be from the surface to a depth of four inches. Subsurface soil samples will be also collected to characterize the subsurface conditions present underneath of the building slabs. Core samples will be biased to locations of observed cracking and/or staining. Core samples of the concrete in these areas will be collected and submitted for laboratory analysis.

Concrete core sampling generally involves use of a diamond core to obtain representative concrete samples. A diamond tipped core barrel will be advanced through the concrete, to the desired depth and the material removed.

#### **4.3.4 Surface Water Investigation**

Two of the recharge basins/sumps receive surface water runoff from the site and exhibit standing water. Also, some of the sumps in the buildings exhibit standing water. Where present, surface water will be collected to characterize the water present. Surface water samples will be collected for laboratory analysis. Surface water sampling for the sumps will consist of grab samples to obtain representative surface water samples.

#### **4.3.5 Field Logbooks / Documentation**

Bound field logbooks will be used to record field activities. Entries will be described in as much detail as practical so that activities can be reconstructed for a particular situation. The following information should be recorded in the field logbook:

- Weather observations
- All field measurements and samples collected
- Equipment used to take measurements along with the date of calibration
- Date and time of sample collection
- Sample description, volume, type of preservative, and number of containers
- Equipment decontamination procedures
- Time of arrival at the Site and the time of departure from the Site

#### **4.3.6 Chain of Custody Procedures**

*Properly completed chain-of-custody (COC) forms will accompany the samples. When transferring the possession of samples, the individuals relinquishing and receiving the samples will sign, date, and note the time on the COC form.*

Samples will be packaged properly for shipment and dispatched to the laboratory for analysis with a separate signed COC record enclosed in each shipping container. Shipping containers will be secured with packaging tape and sealed with signed custody seals.

*Samples will be shipped from the field to the laboratory using a reputable courier or will be driven to the laboratory. To ensure that holding time requirements are met, the selected courier will provide dependable overnight delivery. Samples not shipped overnight, but otherwise properly preserved, will be valid for the maximum holding time period.*

All shipments will be accompanied by the COC record identifying the contents. The back copy will be detached and kept as part of the field records. The original COC record and remaining copies will accompany the shipment.

#### **4.3.7 Equipment Decontamination**

Procedures for equipment decontamination are described in ENSR SOP 7600 (Decontamination of Equipment). Equipment decontamination will be completed following standard procedures at each sampling location and following sample collection. In addition, general equipment conditions will be checked at the end of the day and decontaminated as appropriate. Decontaminated equipment will be stored when not in use within a secure area.

#### **4.3.8 Field Equipment Calibration**

Instruments used to gather, generate, or measure environmental data will be calibrated with sufficient frequency and in such a manner that accuracy and reproducibility of results are consistent with the manufacturer's specifications. Field instruments will be issued through a formal tracking system and operated by trained personnel, in accordance with the appropriate SOPs or manufacturer's specifications. Each instrument used in the field will be examined daily by the Field Team Leader or his/her designee to verify that it is operating properly. Field instruments for the field activities will include organic vapor monitors (e.g., PID).

The frequency of calibration for all instruments will be daily before initial use and at the end of each day. Calibration procedures will be documented in the field records. Documentation will include the date and time of calibration, the identity of the person performing the calibration, the reference standard used, the readings taken, and any corrective action taken.

### **4.4 Laboratory Analysis**

#### **4.4.1 Laboratory Qualifications**

Environmental samples will be analyzed at a commercial laboratory which has a current certificate of approval from New York State's Laboratory Approval Program (ELAP) to perform the required analyses.

The commercial laboratory must have a QC program in place to ensure the reliability and validity of the analysis performed at the laboratory. Analytical procedures should be documented in writing as SOPs; each SOP should include the minimum requirements for the procedure. The internal QC checks differ slightly for each individual procedure but in general the QC requirements include the following:

- Blanks (method, reagent/preparation, instrument)
- MS/MSDs

- Surrogate spikes
- Laboratory duplicates
- LCSs
- Internal standard areas (GC/MS analysis)
- Second column confirmations (GC/ECD analysis)
- Interference checks (ICP analysis)
- Serial dilutions (ICP analysis)

#### 4.4.2 Sample Containers, Reagents, Preservation, and Holding Time Requirements

Sample containers, reagents, preservation, and holding time requirements will be in accordance with SW-846 requirements. The requirements for solid media are summarized in Table 4-2. The requirements for water samples are summarized in Table 4-4.

#### 4.4.3 Analytical Methods

Chemical analysis will include Target Compound List (TCL) VOCs plus TICs, TCL SVOCs plus TICs, glycols, PCBs, TAL Metals plus cyanide, and pH. Concrete core samples will be analyzed by TCLP methods. Solid samples collected from field activities will be analyzed in accordance with the methods listed in Table 4-3. Water samples will be analyzed in accordance with the methods listed in Table 4-5. The method detection limits are provided in Appendix E.

#### 4.4.4 Quality Assurance/Quality Control

The overall QA objective is to develop and implement procedures for field sampling, chain-of-custody, laboratory analysis, and reporting that will provide results that are legally defensible in a court of law.

QA/QC samples will be collected to ensure the data are accurate and meet the data quality objectives. Equipment rinsate blank, field blank, trip blank, method blank, and matrix spike samples will be collected and analyzed to assess the accuracy of the data resulting from the field sampling and analytical programs. The number and type of QA/QC samples to be collected for each media of interest are summarized in Table 4-1.

**Equipment rinsate blanks** are obtained under representative field conditions by running analyte-free deionized/distilled water (provided by the laboratory) through/over sample collection equipment after decontamination and prior to use, and placing it in the appropriate sample

containers for analysis. These samples are used to assess the effectiveness of decontamination procedures. Rinsate blanks will be collected at a frequency of one for every 10 samples, or one per day, on each piece of decontaminated equipment, whichever is less. For disposable equipment, one equipment rinsate blank per sampling event will be collected by pouring analyte-free deionized/distilled water over the newly-unwrapped equipment. Equipment rinsate blanks should contain no target analytes above the quantitation limit.

**Matrix spikes** provide information about the effect of the sample matrix on the preparation and measurement methodology. Matrix spikes for organic analyses are performed in duplicate and are hereinafter referred to as MS/MSD samples. One MS/MSD sample will be collected for every 20 samples or one sample delivery group (SDG) per sample matrix, whichever is less. A single matrix spike (MS) analysis and a laboratory duplicate analysis will be performed for inorganic parameters at a frequency of one for every 20 samples or one SDG per sample matrix, whichever is less. Soil MS or MS/MSD samples require no extra volume as long as the containers are completely filled. Aqueous laboratory duplicate/MS or MS/MSD samples require triplicate volume. The laboratory may report MS/MSD, MS, and laboratory duplicate results for the analytical batch associated with the samples collected for engineering purposes.

**Field duplicate** results are used to assess the combined field and laboratory precision. The results are anticipated to exhibit more variability than laboratory duplicates, which measure only laboratory precision. Duplicate samples will be collected by alternately filling sample bottles from the source being sampled. Field duplicate samples will be collected at a frequency of one for every 20 samples collected or each SDG, whichever is less.

#### **4.4.5 Laboratory Instrument Calibration**

*Calibration is required to ensure that the analytical system is operating correctly and functioning at the proper sensitivity to meet the detection limits established for the method. The analytical methodologies listed in Table 4-3 will be used to analyze the samples collected for this project. These methodologies include specific instrument calibration procedures and frequencies that will be followed by the laboratory. If an instrument has not been properly calibrated and the quality of the data has been adversely affected, the corrective actions outlined in the methodologies will be implemented.*

Calibration procedures for laboratory instruments will consist of initial calibrations, initial calibration verifications, and continuing calibration verification. The SOP for each analysis performed in the laboratory describes the calibration procedures, their frequency, acceptance criteria, and the conditions that will require recalibration.

The laboratory maintains documentation for each instrument which includes the following information: instrument identification, serial number, date of calibration, analyst, calibration solutions, and the samples associated with these calibrations.

#### 4.4.6 Data Deliverables

Laboratory data reduction procedures will be performed according to the following protocol. All information related to analysis will be documented in controlled laboratory logbooks, instrument printouts, or other approved forms. All entries that are not generated by an automated data system will be made neatly and legibly in permanent, waterproof ink. Information will not be erased or obliterated. Corrections will be made by drawing a single line through the error and entering the correct information adjacent to the cross-out. All changes will be initialed, dated, and, if appropriate, accompanied by a brief explanation. Unused pages or portions of pages will be crossed out to prevent future data entry. Analytical laboratory records will be reviewed by the supervisory personnel on a regular basis, and by the Laboratory QA Manager periodically, to verify adherence to documentation requirements.

Data deliverables will be provided within standard turnaround time. The laboratory will provide at least one copy of a hard copy report and one copy of an electronic diskette deliverable (EDD). The EDD will be provided in a mutually-agreeable format. The hard copy data package will be equivalent to ASP Category B deliverable, i.e., consisting of all the information presented in a Category B package, including Category B-like summary forms. This information is summarized below:

- Case narrative (see description below)
- Cross reference of field sample IDs and laboratory IDs
- Method summary
- Chain-of-custody documentation
- Sample receipt checklist
- Dates of sample extraction and analysis
- Description of any data qualifiers used
- Sample results, including units
- Sample preparation information
- Raw data for initial and continuing calibrations
- GC/MS tuning results

- Run logs
- Results for MS/MSDs, method or preparation/calibration blanks, LCSs, internal standard areas, surrogate spikes, laboratory duplicates, ICP serial dilutions, and ICP interference check samples
- Raw data for samples and laboratory QC samples, including labeled and dated chromatograms/ spectra
- Soil and sediment samples will be reported on a dry weight basis. Reporting notes will conform to those stipulated by the method.

The case narrative will include the client name, project name and number, date of issuance, and a discussion of any deviations from analytical strategy, technical problems, and QC failures or non-conformances. The report will be signed by the Laboratory Project Manager.

#### **4.4.7 Data Verification and Validation**

All data will receive an internal review and verification by the laboratory prior to being released. An independent validation of the analytical data will be performed by the consultant or the consultant's contractor.

The consultant or the consultant's subcontractor will provide an independent validation of the laboratory data. A comprehensive validation (Tier III) will be based on USEPA Contract Laboratory Program National Functional Guidelines for Organic Data Review (USEPA 1999), the USEPA Region II Standard Operating Procedure HW-6 (March 2001) and *USEPA Contract Laboratory Program National Functional Guidelines for Inorganic Data Review* (February 1994), where applicable. Twenty-five percent of the data will be subjected to Tier III validation and the remaining will be evaluated using Tier II. If concerns are raised based on the 25-percent Tier III validation, the remaining data will be undergo Tier III validation. All engineering data will be reviewed according to Tier II.

The Tier II review will consist of the following, as appropriate to the method:

- *Completeness of deliverable;*
- Technical holding times;
- Laboratory and field blank contamination;
- Surrogate spike recoveries;
- Field duplicates;

- MS/MSD recoveries and relative percent differences (RPDs);
- Laboratory duplicate RPDs;
- LCS recoveries;
- Initial and continuing calibrations;
- Instrument tuning;
- Internal standard performance;
- ICP serial dilutions; and
- ICP interference check sample results.

Validation will be performed using the QC summary forms presented in the data package. The discovery of significant anomalies or discrepancies during validation of the summary forms may result in a Tier III review and the incorporation of additional review elements into the validation of all data.

The results of the validation will be summarized in validation reports, which will meet the requirements of NYSDEC's Guidance for the Development of Data Usability Summary Reports. Information to be included in the data validation reports will include:

- Samples and analytical parameters included in the validation;
- Validation guidelines used, including any project-specific modifications;
- Review elements;
- Data deficiencies, analytical protocol deviations, and quality control problems, and their impact on the data, and
- Recommendations on resampling/reanalysis.

Qualifiers used will be from the USEPA Region II validation guidelines.



## 5.0 SCHEDULE

The anticipated schedule for implementing the Baseline Investigation is presented on Figure 5-1.

## 6.0 RFA/RFI REPORT

Approximately six weeks after receipt of all final data, ENSR will provide a draft report that summarizes the information generated during implementation of this Work Plan. The report will include the following information and data pertaining to the Site:

- Boring logs.
- Analytical data tables presenting the analytical results for the soil and groundwater samples including comparisons to appropriate SCGs (e.g., NYSDEC Technical Administrative Guidance Memorandum [TAGM] 4046 Recommended Soil Cleanup Objectives [RSCOs]).
- A narrative that summarizes the results of the investigation including a discussion of the physical and analytical results, taking into account existing information and data.
- A graphical conceptual model of the Site in part or in whole.
- In addition, recommendations for future activities, if any, will be made based on the results of the data generated during execution of this RFA/RFI Work Plan.

**TABLES**

---

**Table 2-1  
Summary of RFA/RFI Environmental Investigation Program  
Bayer Hicksville Polymer Plant  
Hicksville, New York**

SWM/AOC Number	Area	Location	Detailed Concerns	Previous Investigation/ Remedial Action	Recommendation	Approximate Number and Depth of Samples	Sample Type	Method	Analyses	Notes
1	Plant 1	Less Than 90 Day Storage Unit	potential releases of hazardous materials	Closed pursuant to Closure Plan for Plants #3 and #1 (ENSR, October 2002). Area has been cleaned, rinsate results provided in Appendix C. No visible staining remains.	No Further Action	N/A	N/A	N/A	N/A	Sampling being conducted at adjacent AOC areas 2 and 39.
2	Plant 1	Laboratory Setafite Accumulation Area Walkway connecting Plant 1 and Warehouse	potential releases of hazardous materials	N/A	Assess Environmental Conditions	Four (4) discrete soil samples (AOC2-1 through AOC2-4) along western laboratory wall.	Subsurface Soil	Geoprobe™	VOCs SVOCs Glycols	See Figure 2-1 for sampling location(s).
3	Plant 1	Wastewater Tanks 1, 11A, and 11B	potential VOC and/or heavy metals impacts from plant wastewater	N/A	Assess Environmental Conditions	Two (2) concrete core samples (AOC3-1 and AOC3-2), and two subsurface soil samples (AOC3-3 and AOC 3-4), one each in south corner of Plant 1, the other pair in the middle of the southern wall of Plant 1.	Concrete and Soil	Core and Geoprobe™	TCLP- Concrete All-Soil	See Figure 2-2 for sampling location(s).
4	Plant 1	Former Liquid Incinerator Area	potential releases of hazardous materials	N/A	Assess Environmental Conditions	One (1) concrete core sample (AOC4-1) and one subsurface soil sample (AOC4-2) in the middle of AOC 4 located on the eastern wall inside of Plant 1.	Concrete and Soil	Core and Geoprobe™	TCLP	Additional sampling is being conducted in the vicinity of AOC 4. See Figure 2-3 for sampling location(s).
5	Plant 1	Transfer Station and Associated Piping	potential releases of hazardous materials	N/A	Assess Environmental Conditions	Two (2) discrete soil samples (AOC5-1 and AOC5-2) southwest of Plant 1 and east of Plant 1 Warehouse.	Subsurface Soil	Geoprobe™	VOCs SVOCs Glycols	Additional samples being collected in association with AOC 6. See Figures 2-2 and 2-4 for sampling location(s).
6	Plant 1 Transfer Station	Glycol Tanks 29 and 30	potential releases of glycols	N/A	Assess Environmental Conditions	One (1) discrete soil sample (AOC6-1) west of Glycol Tanks 29 and 30.	Subsurface Soil	Geoprobe™	VOCs SVOCs Glycols	Sample will be taken at location closest to transfer port. Additional samples being collected in association with AOC 6. See Figure 2-4 for sampling location(s).
7	Plant 1 Transfer Station	Station Adipic Acid Silos and Wastewater Area	potential releases of adipic acid  potential VOC and/or heavy metals impacts from plant wastewater	N/A	Assess Environmental Conditions	Two (2) discrete soil samples (AOC7-1 and AOC7-2) along eastern wall of Plant 1.	Subsurface Soil	Geoprobe™	VOCs SVOCs Glycols TAL Metals+ Cyanide	See Figures 2-2, 2-4, and 2-10 for sampling location(s).
8	Plant 1	Underground Storage Tank	potential releases from UST	UST was closed in place in 1989 by RUCO through Nassau County and NYSDOH.	No Further Action	N/A	N/A	N/A	N/A	
9	Plant 1	Underground Storage Tank	potential releases from UST	UST was removed in 1989 by RUCO through Nassau County and NYSDOH.	No Further Action	N/A	N/A	N/A	N/A	
10	Plant 2	Underground Storage Tank	potential releases from UST	UST was removed in 1993 by RUCO through Nassau County and NYSDOH.	No Further Action	N/A	N/A	N/A	N/A	
11	Plant 1	Boiler Condensate Run-Off	releases of condensate from boiler	N/A	Assess Environmental Conditions	Three (3) discrete soil samples (AOC11-1 through AOC11-3) east of Plant 1 and south of AOC 4.	Subsurface Soil Sediment	Geoprobe™ /Grab	VOCs SVOCs Glycols PCBs	Samples will be collected along the surface flowpath from the spill area to the sump adjacent to the Pilot Plant, and from the sump. See Figure 2-3 for sampling location(s).
12	Plant 2	Waste Accumulation Area	potential releases of wastes	N/A	Assess Environmental Conditions	One (1) discrete soil sample (AOC12-1) in the center of AOC 12.	Subsurface Soil	Geoprobe™	VOCs SVOCs Glycols	See Figure 2-3 for sampling location(s).
13	Plant 2	Former RCRA Greater than 90 Day Storage Area	potential releases of hazardous wastes	Closed pursuant to RCRA in 1985. No visible staining remains.	Confirm Environmental Conditions	One (1) discrete sub-surface soil sample (AOC 13-1) from the area where there was a potential for release during operation	Subsurface Soil	Geoprobe™	VOCs SVOCs Glycols TAL Metals+ Cyanide	See Figure 2-3 for Sampling Location.
14	Plant 2	Waste Compactor and Scrap Metal Area	potential releases of wastes	N/A	Assess Environmental Conditions	Two (2) discrete concrete samples (AOC14-1 and AOC14-2) east of Plant 2.	Concrete	Core	TCLP	See Figure 2-3 for sampling location(s).
15	Plant 2	Distillate Wastewater Tank 2	potential releases of distillate wastewater	N/A	Assess Environmental Conditions	One (1) discrete sediment sample (AOC15-1) in the center of AOC 15 plus one discrete concrete and one subsurface soil sample (AOC15-2 and AOC15-3)	Sediment, Concrete, and Subsurface Soil	Grab, Core and Geoprobe™	VOCs SVOCs Glycols PCBs TAL Metals+ Cyanide pH TCLP- Concrete	Sample AOC15-1 will be taken from the floor drain directly east of tank. See Figure 2-5 for sampling location(s).
16	Plant 2	Reactor 4 Knockout Tank	releases from tank staining observed on tank	N/A	Assess Environmental Conditions	One (1) discrete concrete sample (AOC16-1) and one discrete subsurface soil sample (AOC 16-2) in the center of AOC 16.	Concrete and Subsurface Soil	Core and Geoprobe™	TCLP	Sample will be taken below former tank location. See Figures 2-5 and 2-6 for sampling location(s).
17	Plant 2	Dimethylformamide (DMF) pump overflow	potential releases of dimethylformamide (DMF)	N/A	Assess Environmental Conditions	One (1) discrete soil sample (AOC17-1) in the center of AOC 17 which is outside of Plant 2 along the eastern wall and north of AOC 16.	Subsurface Soil	Geoprobe™	VOCs SVOCs Glycols	See Figures 2-5 and 2-6 for sampling location(s).
18	Plant 2 Transfer Station	Plant 2 Hexandiol Tank	potential releases of hexandiol	N/A	Assess Environmental Conditions	Three (3) discrete soil samples (AOC18-1 through AOC18-3) west of Plant 2.	Subsurface Soil	Geoprobe™	VOCs SVOCs Glycols	See Figure 2-5 for sampling location(s).

**Table 2-1**  
**Summary of RFA/RFI Environmental Investigation Program**  
**Bayer Hicksville Polymer Plant**  
**Hicksville, New York**

SWMU/AOC Number	Area	Location	Detailed Concerns	Previous Investigation/ Remedial Action	Recommendation	Approximate Number and Depth of Samples	Sample Type	Method	Analyses	Notes
19	Plant 2	Fume Incinerator	potential releases from incinerator	N/A	No Further Action	N/A	N/A	N/A	N/A	Any waste releases from the incinerator would have been in the form of fumes and would be to the air.
20	Plant 3 Warehouse	RCRA Less Than 90 Day Storage Unit	potential releases of hazardous wastes	Closed pursuant to Closure Plan for Plants #3 and #1 (ENSR, October 2002). Area has been cleaned, rinse results provided in Appendix C. No visible staining remains.	Confirm Environmental Conditions	One (1) discrete concrete sample (AOC20-1) and one discrete subsurface soil sample (AOC20-2) in the center of the AOC area.	Concrete and Subsurface Soil	Core and Geoprobe™	VOCs SVOCs Glycols TAL Metals+ Cyanide TCLP- Concrete	See Figure 2-7 for sampling location(s).
21A	Plant 3 Transfer Station	Adipic Acid Silos	potential releases of adipic acid	N/A	Assess Environmental Conditions	Two (2) discrete soil samples (AOC21A-1 and AOC21A-2) along eastern wall of Plant 3.	Subsurface Soil	Geoprobe™	VOCs SVOCs Glycols pH	See Figure 2-7 for sampling location(s).
21B	Plant 3 Transfer Station	Adipic Acid Silos	potential releases of adipic acid	N/A	Assess Environmental Conditions	One (1) discrete sediment sample (AOC21B-1) in storm drain of AOC 21B.	Sediment	Grab	VOCs SVOCs Glycols pH	See Figure 2-8 for sampling location(s).
22	Plant 3	Tote Storage Area	potential releases of wastes	N/A	Assess Environmental Conditions	Four (4) discrete soil samples (AOC22-1 through AOC22-4). Two samples will be collected through the asphalt, two samples will be collected off the edge of the asphalt, downslope.	Subsurface Soil	Geoprobe™	VOCs SVOCs Glycols	See Figure 2-7 for sampling location(s).
23	Plant 3 Warehouse	Non-hazardous Waste Accumulation	potential releases of non-hazardous wastes	N/A	Assess Environmental Conditions	Two (2) sediment samples (AOC23-1 and AOC23-2), southwest corner of Plant 3 and eastern wall of Plant 3. One concrete and one soil (AOC23-3 and AOC23-4) to be collected as well.	Sediment, Concrete, and Subsurface Soil	Grab, Core and Geoprobe™	VOCs SVOCs Glycols PCB TAL Metals+ Cyanide pH TCLP- Concrete	Sediment samples will be collected from the open pipe trenches located inside the building where wastes are assumed to have accumulated. See Figure 2-7 for sampling location(s). Concrete and soil samples will be collected within the AOC area.
24	Tank Farm	Transfer Station for the Tank Farm	potential releases from tank farm	N/A	Assess Environmental Conditions	Eight (8) discrete soil samples (AOC24-1 through AOC24-8) along the transfer station and inside the containment areas.	Subsurface Soil	Geoprobe™	VOCs SVOCs Glycols	Samples will be collected from below the intersecting expansion joints in the concrete and near cracks in containment. See Figure 2-6 for sampling location(s). Note that samples will be collected from both the surface (0.0-0.5 feet bgs) and the subsurface (0.5 to 2.0) feet bgs.
25	Pilot Plant	Former Soil Pile Area removed from AOC 10	PCB-impacted soils	Soil pile removed as part of remediation by HCPC/OCC for OU 02. Remediation was completed in 2002.	No Further Action	N/A	N/A	N/A	N/A	
26	Miscellaneous	Whole site	Historical Spills	N/A	No Further Action	N/A	N/A	N/A	N/A	Historical spills will be addressed as part of other AOCs. No actual delineated AOC area.
27A	Shipping/Receiving	Non-hazardous, off-Spec, damaged product and Raw Material Storage	potential releases from off-spec and/or damaged product and/or raw materials	N/A	Assess Environmental Conditions	Two (2) discrete surface soil samples (AOC27A-1 and AOC27A-2) northwestern side of Plant 3.	Surface Soil	Hand Tools	VOCs SVOCs Glycols	See Figure 2-9 for sampling location(s).
27B	Shipping/Receiving	Non-hazardous, off-Spec, damaged product and Raw Material Storage	potential releases from off-spec and/or damaged product and/or raw materials	N/A	Assess Environmental Conditions	Two (2) discrete surface soil samples (AOC27B-1 and AOC27B-2) north of Plant 1 Warehouse.	Surface Soil	Hand Tools	VOCs SVOCs Glycols	See Figure 2-1 for sampling location(s).
27C	Shipping/Receiving	Non-hazardous, off-Spec, damaged product and Raw Material Storage	potential releases from off-spec and/or damaged product and/or raw materials	N/A	Assess Environmental Conditions	Two (2) discrete surface soil samples (AOC27C-1 and AOC27C-2) north of Plant 1 Laboratory.	Surface Soil	Hand Tools	VOCs SVOCs Glycols	See Figure 2-8 for sampling location(s).
27D	Shipping/Receiving	Non-hazardous, off-Spec, damaged product and Raw Material Storage	potential releases from off-spec and/or damaged product and/or raw materials	N/A	Assess Environmental Conditions	One (1) discrete soil sample (AOC27D-1) west of Plant 1 and north of AOC 5.	Subsurface Soil	Geoprobe™	VOCs SVOCs Glycols	Additional samples being collected in the area associated with AOC-5. See Figure 2-2 for sampling location(s).
27E	Shipping/Receiving	Non-hazardous, off-Spec, damaged product and Raw Material Storage	potential releases from off-spec and/or damaged product and/or raw materials	Soil pile removed as part of remediation by HCPC/OCC for OU 02. Remediation was completed in 2002.	No Further Action	N/A	N/A	N/A	N/A	
27F	Shipping/Receiving	Non-hazardous, off-Spec, damaged product and Raw Material Storage	potential releases from off-spec and/or damaged product and/or raw materials	N/A	Assess Environmental Conditions	Two (2) discrete soil samples (AOC27F-1 and AOC27F-2) east of Plant 2.	Subsurface Soil	Geoprobe™	VOCs SVOCs Glycols	See Figures 2-5 and 2-6 for sampling location(s).
27G	Shipping/Receiving	Non-hazardous, off-Spec, damaged product and Raw Material Storage	potential releases from off-spec and/or damaged product and/or raw materials	N/A	Assess Environmental Conditions	Two (2) discrete soil samples (AOC27G-1 and AOC27G-2) northwest of Sump 4.	Subsurface Soil	Geoprobe™	VOCs SVOCs Glycols	See Figures 2-5 and 2-6 for sampling location(s).
27H	Shipping/Receiving	Non-hazardous, off-Spec, damaged product and Raw Material Storage	potential releases from off-spec and/or damaged product and/or raw materials	N/A	Assess Environmental Conditions	Two (2) discrete soil samples (AOC27H-1 and AOC27H-2) east of AOC 24.	Subsurface Soil	Geoprobe™	VOCs SVOCs Glycols	See Figure 2-6 for sampling location(s).

**Table 2-1**  
**Summary of RFA/RFI Environmental Investigation Program**  
**Bayer Hicksville Polymer Plant**  
**Hicksville, New York**

SWMU/AOC Number	Area	Location	Detailed Concerns	Previous Investigation/ Remedial Action	Recommendation	Approximate Number and Depth of Samples	Sample Type	Method	Analyses	Notes
27I	Shipping/ Receiving	Non-hazardous, off-Spec, damaged product and Raw Material Storage	potential releases from off-spec and/or damaged product and/or raw materials	N/A	Assess Environmental Conditions	Two (2) discrete soil samples (AOC27I-1 and AOC27I-2) north of Plant 2.	Subsurface Soil	Geoprobe™	VOCs SVOCs Glycols	See Figures 2-5 and 2-6 for sampling location(s).
27J	Shipping/ Receiving	Non-hazardous, off-Spec, damaged product and Raw Material Storage	potential releases from off-spec and/or damaged product and/or raw materials	N/A	Assess Environmental Conditions	Two (2) discrete soil samples (AOC27J-1 and AOC27J-2) through asphalt southwest of Plant 2.	Subsurface Soil	Geoprobe™	VOCs SVOCs Glycols	See Figure 2-3 for sampling location(s).
28	Recharge Basin	Sump #1	release of stormwater and plant wastewater to sump area	This AOC is addressed under HCPC/OCC consent order.	No Further Action	N/A	N/A	N/A	N/A	
29	Recharge Basin	Sump #2	release of stormwater and plant wastewater to sump area	This AOC is addressed under HCPC/OCC consent order.	No Further Action	N/A	N/A	N/A	N/A	
30	Recharge Basin	Sump #3 Stormwater	release of stormwater and plant wastewater to sump area	N/A	Assess Environmental Conditions	Three (3) discrete sediment samples (AOC30-1, AOC30-2, and AOC30-3) south of Pilot Plant.	Sediment	Grab	VOCs SVOCs Glycols PCBs	See Figure 2-9 for sampling location(s).
31	Recharge Basin	Sump #4 SPDES Discharge	release of stormwater and plant wastewater to sump area	N/A	Assess Environmental Conditions	Two (2) discrete sediment samples (AOC31-1 and AOC31-2) east of Plant 2.	Sediment	Grab	VOCs SVOCs Glycols PCBs	Even though the SPDES permit was terminated in the early 90's, it is believed that stormwater continues to discharge into sump #4. The samples will be collected near the outfall of the sump. See Figures 2-5 and 2-6 for sampling location(s).
32	Recharge Basin	Sump #5	release of stormwater and plant wastewater to sump area	Sump #5 was filled in by previous owners.	Confirm Environmental Conditions	One (1) discrete soil sample (AOC 32-1) north of Plant 2.	Subsurface Soil	Geoprobe™	PCBs	See Figure 2-6 for sampling location(s).
33	Recharge Basin	Sump #6	release of stormwater and plant wastewater to sump area	Sump #6 was filled in by previous owners.	Confirm Environmental Conditions	One (1) discrete soil sample (AOC 33-1) north of Plant 2.	Subsurface Soil	Geoprobe™	PCBs	See Figure 2-6 for sampling location(s).
34	Cooling Tower	Cooling Tower Sump	potential releases of cooling water	N/A	No Further Action	N/A	N/A	N/A	N/A	No known release of chemicals; non-contact cooling water.
35A	Admin	Septic Tank/French Drains East of Administration Building	releases of wastes	N/A	Assess Environmental Conditions	Two (2) discrete soil samples (AOC35A-1 and AOC35A-2) east of Administration Building.	Subsurface Soil	Geoprobe™	VOCs SVOCs Glycols TAL Metals+ Cyanide	Subsurface soil samples will be collected directly adjacent to the systems. One sample will be collected from the tank area and one sample will be collected from the drainfield. See Figure 2-9 for sampling location(s).
35B	Plant 1	Septic Tank/French Drains Northwest of Plant 1	releases of wastes	N/A	Assess Environmental Conditions	Two (2) discrete soil samples (AOC35B-1 and AOC35B-2) northwest of Plant 1.	Subsurface Soil	Geoprobe™	VOCs SVOCs Glycols TAL Metals+ Cyanide	Subsurface soil samples will be collected directly adjacent to the systems. One sample will be collected from the tank area and one sample will be collected from the drainfield. See Figure 2-8 for sampling location(s).
35C	Plant 1	Septic Tank/French Drains West of Plant 1	releases of wastes	N/A	Assess Environmental Conditions	Three (3) discrete soil samples (AOC35C-1, AOC35C-2 and AOC35C-3) west of Plant 1.	Subsurface Soil	Geoprobe™	VOCs SVOCs Glycols TAL Metals+ Cyanide	Subsurface soil samples will be collected directly adjacent to the systems. One sample will be collected from the tank area and one sample will be collected from the drainfield. See Figure 2-1 for sampling location(s).
35D	Plant 1	Septic Tank/French Drains Southwest of Plant 1	releases of wastes	N/A	Assess Environmental Conditions	Two (2) discrete soil samples (AOC35D-1 and AOC35D-2) southwest of Plant 1.	Subsurface Soil	Geoprobe™	VOCs SVOCs Glycols TAL Metals+ Cyanide	Subsurface soil samples will be collected directly adjacent to the systems. One sample will be collected from the tank area and one sample will be collected from the drainfield. See Figure 2-1 for sampling location(s).
35E	Plant 2	Septic Tank/French Drains Southwest of Plant 2	releases of wastes	N/A	Assess Environmental Conditions	Two (2) discrete soil samples (AOC35E-1 and AOC35E-2) southwest of Plant 2.	Subsurface Soil	Geoprobe™	VOCs SVOCs Glycols TAL Metals+ Cyanide	Subsurface soil samples will be collected directly adjacent to the systems. One sample will be collected from the tank area and one sample will be collected from the drainfield. See Figure 2-5 for sampling location(s).
35F	Pilot Plant	Septic Tank/French Drains Northwest of Pilot Plant	releases of wastes	N/A	Assess Environmental Conditions	Two (2) discrete soil samples (AOC35F-1 and AOC35F-2) northwest of Pilot Plant.	Subsurface Soil	Geoprobe™	VOCs SVOCs Glycols TAL Metals+ Cyanide	Subsurface soil samples will be collected directly adjacent to the systems. One sample will be collected from the tank area and one sample will be collected from the drainfield. See Figure 2-3 for sampling location(s).
35G	Admin	Septic Tank/French Drains South of Administration Building	releases of wastes	N/A	Assess Environmental Conditions	Two (2) discrete soil samples (AOC35G-1 and AOC35G-2) south of Administration Building.	Subsurface Soil	Geoprobe™	VOCs SVOCs Glycols TAL Metals+ Cyanide	Subsurface soil samples will be collected directly adjacent to the systems. One sample will be collected from the tank area and one sample will be collected from the drainfield. See Figure 2-9 for sampling location(s).
36	Admin	Admin Building Closed Laboratory Storage Area	potential releases of wastes	N/A	Assess Environmental Conditions	One (1) discrete concrete sample (AOC36-1) in the center of AOC 36 which is south of the Administration Building.	Concrete	Core	TCLP	See Figure 2-9 for sampling location(s).
37	Plant 2	DOA Sump	potential releases of wastes	N/A	Assess Environmental Conditions	One (1) sediment sample (AOC37-1) in the center of AOC 37, which is along the eastern wall of Plant 2. One concrete sample (AOC37-2) and one subsurface soil (AOC37-3) within the AOC for building slab evaluation.	Sediment, Concrete, and Subsurface Soil	Grab, Core and Geoprobe™	VOCs SVOCs Glycols TAL Metals+ Cyanide TCLP- Concrete	See Figure 2-5 for sampling location(s).

**Table 2-1**  
**Summary of RFA/RFI Environmental Investigation Program**  
**Bayer Hicksville Polymer Plant**  
**Hicksville, New York**

SWMU/AOC Number	Area	Location	Detailed Concerns	Previous Investigation/ Remedial Action	Recommendation	Approximate Number and Depth of Samples	Sample Type	Method	Analyses	Notes
38	Plant 2	Exterior Trench	potential releases of wastes	N/A	Assess Environmental Conditions	One (1) sediment sample (AOC38-1) northeast of Plant 2.	Sediment	Grab	VOCs SVOCs Glycols	See Figure 2-5 for sampling location(s).
39	Plant 1	Electrical Transformers	potential releases from transformers	N/A	Assess Environmental Conditions	Three (3) discrete soil samples (AOC39-1, AOC39-2 and AOC39-3) along eastern wall of Plant 1 in the former transformer bay area.	Subsurface Soil	Geoprobe™	SVOCs Glycols PCBs	See Figure 2-7 for sampling location(s).
40	Plant 3	Trench System	potential releases of wastes	N/A	Assess Environmental Conditions	Three (3) sediment samples (AOC40-1, AOC40-2, and AOC40-3) along length of trench.	Sediment	Grab	VOCs SVOCs Glycols TAL Metals+ Cyanide	See Figure 2-3 for sampling location(s).
41	Plant 1	Stained Concrete in Warehouse	stains from leakage of products and/or raw materials	N/A	Assess Environmental Conditions	Three (3) discrete concrete samples (AOC41-1 to AOC41-3) and three subsurface soil samples (AOC41-4 to AOC41-6) along eastern wall.	Concrete and Subsurface Soil	Core and Geoprobe™	TCLP- Concrete All-Soil	The concrete and soil samples for evaluation of the building slab are to be randomly distributed and collected within the Warehouse.
42	Plant 1	Center Trench	potential releases of wastes	N/A	Assess Environmental Conditions	Three (3) sediment samples (AOC42-1, AOC42-2, and AOC42-3) along length of trench.	Sediment	Grab	VOCs SVOCs Glycols TAL Metals+ Cyanide	
43	Plant 1	Sump in Foundation, NW End of Plant	potential releases of wastes	N/A	Assess Environmental Conditions	One (1) discrete sediment sample (AOC43-1) and one (1) grab water sample (AOC43-1W).	Sediment	Grab	VOCs SVOCs Glycols TAL Metals+ Cyanide	See Figure 2-3 for sampling location(s).
44	Plant 1	Sump in Foundation, SE End of Plant	potential releases of wastes	N/A	Assess Environmental Conditions	One (1) discrete sediment sample (AOC44-1) and one (1) grab water sample (AOC44-1W).	Sediment	Grab	VOCs SVOCs Glycols TAL Metals+ Cyanide	
45	Pilot Plant	Sump in NW Corner of Plant (interior and exterior)	potential releases of wastes	N/A	Assess Environmental Conditions	Two (2) discrete sediment samples (AOC45-1 and AOC45-2) from base of sump. One (1) water sample if water is present. One concrete and one subsurface soil (AOC45-3 and AOC45-4) as well.	Sediment, Water, Concrete and Subsurface Soil	Grab, Core and Geoprobe™	VOCs SVOCs Glycols TAL Metals+ Cyanide TCLP- Concrete	See Figure 2-3 for sampling location(s).
46	Plant 2	Scale Area and Circular Plate Area in Foundation	potential releases of wastes	N/A	Assess Environmental Conditions	Two (2) sediment samples (AOC 46-1 and AOC46-2), one sample from scale area and one circular plate area in foundation. Also, one concrete and one subsurface soil sample (AOC46-3 and AOC46-4) for building slab evaluation.	Sediment, Concrete, and Subsurface Soil	Grab, Core and Geoprobe™	VOCs SVOCs Glycols TAL Metals+ Cyanide TCLP- Concrete	See Figure 2-5 for sampling location(s).
47	Plant 2	Trench System and Sump Leading to Sump 4	potential releases of wastes	N/A	Assess Environmental Conditions	Three (3) discrete sediment samples (AOC47-1, AOC47-2, and AOC47-3) along trench.	Sediment	Core	VOCs SVOCs Glycols TAL Metals+ Cyanide	
48	Plant 1	Empty Drum Storage at NW End of Warehouse	potential releases of wastes	N/A	Assess Environmental Conditions	Two (2) discrete soil samples (AOC 48-1 and AOC48-2).	Soil	Geoprobe	VOCs SVOCs Glycols TAL Metals+ Cyanide	See Figure 2-1 for sampling location(s).
49	Pilot Plant	Trench around East Wall	potential releases of wastes	N/A	Assess Environmental Conditions	Two (2) discrete sediment samples (AOC 49-1 and AOC49-2) along trench. Also, one concrete and one subsurface soil sample (AOC49-3 and AOC49-4) for building slab evaluation.	Sediment, Concrete, and Subsurface Soil	Grab, Core and Geoprobe™	VOCs SVOCs Glycols TAL Metals+ Cyanide TCLP- Concrete	See Figure 2-3 for sampling location(s).

**Notes:**

TCLP includes VOCs, SVOCs, Glycols, TAL Metals, and Cyanide  
 Where subsurface soil samples are collected below concrete samples, the soil samples will be analyzed for the full list of parameters.  
 Only concrete samples will be analyzed by TCLP methods.

**Table 4-1**  
**Summary of Sampling and Analysis Program**  
**Bayer Hicksville Polymer Plant**  
**Hicksville, New York**

Sample Matrix	Laboratory Analyses	Number of Investigative Samples	Number of Field QC Samples		Number of MS/MSD <sup>(c)</sup> Samples	Number of MS/LD <sup>(d)</sup> Samples
			Duplicates <sup>(a)</sup>	Blanks <sup>(b)</sup>		
Soil	TCL <sup>(e)</sup> VOC + TICS <sup>(f)</sup>	87	5	9	5	0
	TCL SVOC + TICS GLYCOLS	90	5	9	5	0
	PCBs <sup>(g)</sup>	10	1	1	1	0
	TAL Metals <sup>(h)</sup>	48	3	5	0	3
	Cyanide	48	3	5	0	3
	pH	8	1	1	0	3
Sediment	TCL VOC + TICS	33	2	4	2	0
	TCL SVOC + TICS GLYCOLS	33	2	4	2	0
	PCBs	24	2	3	2	0
	TAL Metals <sup>(h)</sup>	10	1	1	0	1
	Cyanide	10	1	1	0	1
	pH	7	1	1	0	1
Water	TCL VOC + TICS	5	1	1	1	0
	TCL SVOC + TICS GLYCOLS	5	1	1	1	0
	PCBs	2	1	1	1	0
	TAL Metals <sup>(h)</sup>	3	1	1	0	1
	Cyanide	3	1	1	0	1
	pH	0	0	0	0	1
Concrete	TCLP	17	1	1	1	1

**Notes:**

- (a) Duplicate samples will be collected at a frequency of 1 duplicate per 20 environmental samples.
- (b) Field blanks will be collected at a frequency of 1 per 10 environmental samples.
- (c) MS/MSD - Matrix Spike/Matrix Spike Duplicates will be collected for organic analysis at a frequency of 1 MS/MSD per 20 environmental samples
- (d) MS/LD - Matrix Spike/Laboratory Duplicates will be collected for inorganic analysis at a frequency of 1 MS/LD per 20 environmental samples
- (e) TCL - Target Compound List excluding pesticides and herbicides.
- (f) TICS - Tentatively Identified Compounds
- (g) PCB -Polychlorinated biphenyls.
- (h) TAL Metals+ - Aluminum, Antimony, Arsenic, Barium, Beryllium, Cadmium, Calcium, Chromium, Cobalt, Copper, Iron, Lead, Magnesium, Manganese, Mercury, Nickel, Potassium, Selenium, Silver, Sodium, Thallium, Vanadium, and Zinc.
- (i) N/A - Not Applicable.
- (k) TCLP - VOCs, SVOCs, Glycols, TAL Metals plus Cyanide



**Table 4-2**  
**Containers, Preservation, and Holding Times for Solid Samples**  
**Bayer Hicksville Polymer Plant**  
**Hicksville, New York**

Parameter	Container	Preservation	Holding Time <sup>(a)</sup>
TCL VOC + TICS	1 - 2 ounce glass jar	Cool, 4°C, protect from light minimal headspace	48 hours
TCL SVOC + TICS (excluding Herbicides and Pesticides)	1 - 8 oz. amber glass bottle with teflon-lined cap	Cool, 4°C	14 days until extraction 40 days after extraction
Glycols	1 - 8 oz. glass bottle with teflon-lined cap	Cool, 4°C	14 days
PCBs	1 - 4 oz. amber glass bottle with teflon-lined cap	Cool, 4°C	14 days until extraction 40 days after extraction
Metals TAL + cyanide	1 - 8 oz. glass bottle with teflon-lined cap	Cool, 4°C	6 months to analyze 28 days for Hg
<b>Notes:</b>			
(a) Holding time is the maximum time that a sample may be held prior to analysis and still be considered valid. Holding times are calculated from the date of collection.			

**Table 4-3**  
**Analytical Methods for Solid Samples**  
**Bayer Hicksville Polymer Plant**  
**Hicksville, New York**

<b>Parameter</b>	<b>Analytical Methods</b>	<b>Reference<sup>(a)</sup></b>
VOCs + TICS	8260B	SW-846
SVOCs + TICS	8270D	SW-846
Glycols	8015B	SW-846
PCBs	8082	SW-846
Metals	6010a/6020	SW-846
Hg	7471	SW-846
pH	9045C	SW-846
Cyanide	9010B	SW-846
TCLP VOCs	8260B	SW-846
TCLP SVOCs	8270C	SW-846
TCLP Metals	6010B/7000A	SW-846
TCLP Extraction	1311	SW-846

Method Detection Limits are provided in Appendix E.

**Notes:**

(a) USEPA, Test Methods for Evaluating Solid Wastes. Physical/Chemical Methods, SW846, Third Edition including 1992, 1993, 1994, 1995 and 1996 updates.

**Table 4-4**  
**Containers, Preservation, and Holding Times for Water Samples**  
**Bayer Hicksville Polymer Plant**  
**Hicksville, New York**

Parameter	Container	Preservation	Holding Time <sup>(a)</sup>
TCL VOC + TICS	3 - 40 mL glass vial	HCl, Cool, 4°C, protect from light minimal headspace	14 days
TCL SVOC + TICS (excluding Herbicides and Pesticides)	2 - 1 liter amber glass bottle with teflon-lined cap	Cool, 4°C	14 days until extraction 40 days after extraction
Glycols	1 -1 liter amber glass bottle with teflon-lined cap	Cool, 4°C	14 days
PCBs	2 -1 liter amber glass bottle with teflon-lined cap	Cool, 4°C	14 days until extraction 40 days after extraction
Metals TAL + cyanide	1 - 8 oz. Plastic/250 mL bottle with teflon-lined Cap , Cn is 125 mL glass	HNO <sub>3</sub> , Cool, 4°C  Cn is NaOH	6 months to analyze 28 days for Hg
<b>Notes:</b>			
(a) Holding time is the maximum time that a sample may be held prior to analysis and still be considered valid. Holding times are calculated from the date of collection.			

**Table 4-5**  
**Analytical Methods for Liquid Samples**  
**Bayer Hicksville Polymer Plant**  
**Hicksville, New York**

<b>Parameter</b>	<b>Analytical Methods</b>	<b>Reference<sup>(a)</sup></b>
VOCs + TICS	8260B	SW-846
SVOCs + TICS	8270D	SW-846
Glycols	8015B	SW-846
PCBs	8082	SW-846
Metals	6010a/6020	SW-846
Hg	7471	SW-846
pH	9045C	SW-846
Cyanide	9010B	SW-846
TCLP VOCs	8260B	SW-846
TCLP SVOCs	8270C	SW-846
TCLP Metals	6010B/7000A	SW-846
TCLP Extraction	1311	SW-846

Method Detection Limits are provided in Appendix E.

**Notes:**

(a) USEPA, Test Methods for Evaluating Solid Wastes. Physical/Chemical Methods, SW846, Third Edition including 1992, 1993, 1994, 1995 and 1996 updates.

**FIGURES**



Source: USGS  
 Hicksville, NY  
 Topographic Quad

Scale 1" = 2,000'

**Bayer Hicksville Polymer Plant**  
**Site Location**  
*RFA/RFI Work Plan*

Hicksville, New York

August 2003

Job No. 04690-079-0005

**FIGURE 1-1**



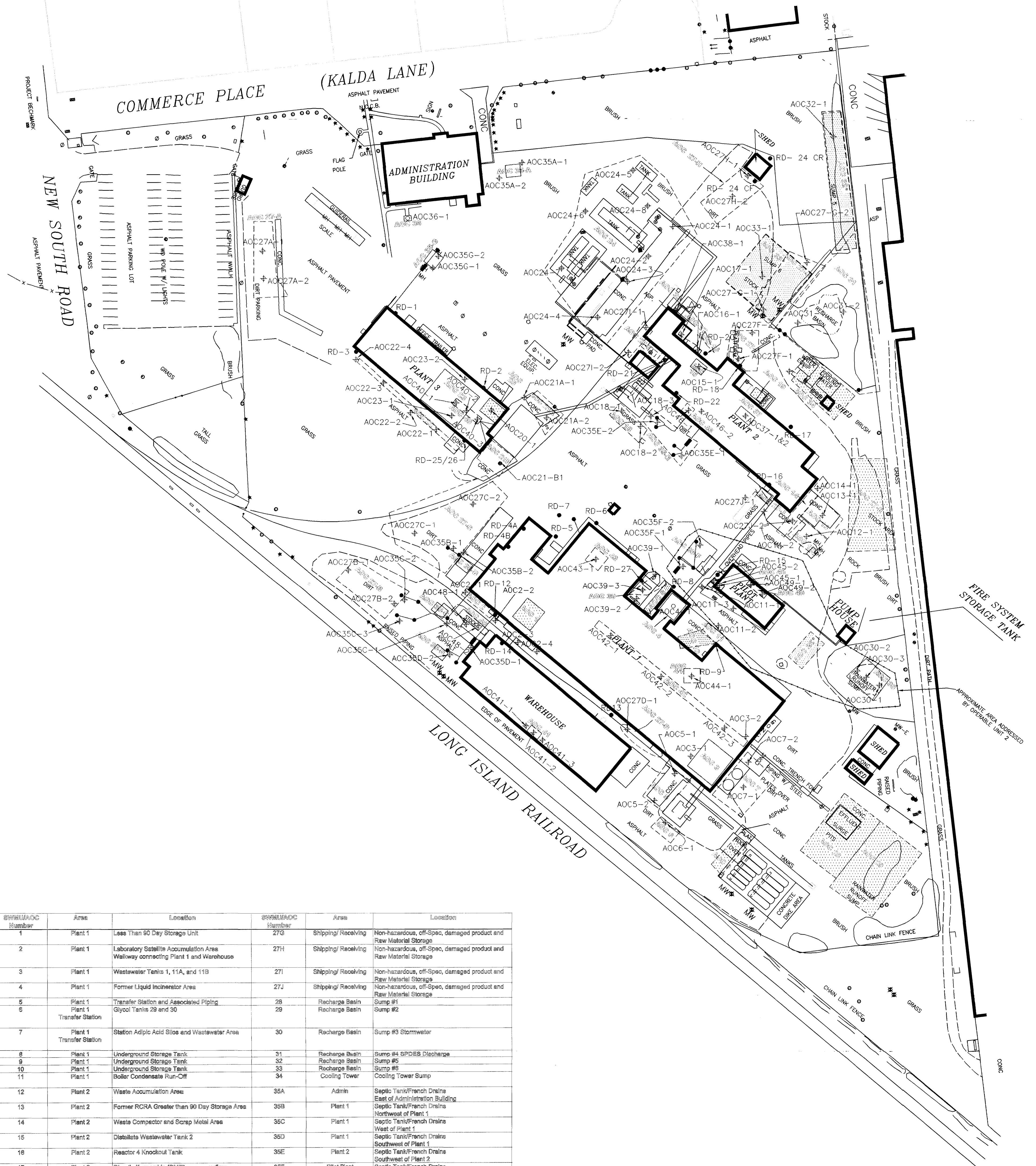

SWW/UA/AOC Number	Area	Location	SWW/UA/AOC Number	Area	Location
1	Plant 1	Less Than 90 Day Storage Unit	27G	Shipping/Receiving	Non-hazardous, off-spec, damaged product and Raw Material Storage
2	Plant 1	Laboratory Satellite Accumulation Area Walkway connecting Plant 1 and Warehouse	27H	Shipping/Receiving	Non-hazardous, off-spec, damaged product and Raw Material Storage
3	Plant 1	Wastewater Tanks 1, 11A, and 11B	27I	Shipping/Receiving	Non-hazardous, off-spec, damaged product and Raw Material Storage
4	Plant 1	Former Liquid Incinerator Area	27J	Shipping/Receiving	Non-hazardous, off-spec, damaged product and Raw Material Storage
5	Plant 1	Transfer Station and Associated Piping	28	Recharge Basin	Recharge Basin
6	Plant 1	Glycol Tanks 28 and 30	29	Recharge Basin	Sump #2
7	Plant 1	Station Adipic Acid Silos and Wastewater Area	30	Recharge Basin	Sump #3 Stormwater
8	Plant 1	Underground Storage Tank	31	Recharge Basin	Sump #4 SPDES Discharge
9	Plant 1	Underground Storage Tank	32	Recharge Basin	Sump #5
10	Plant 1	Underground Storage Tank	33	Recharge Basin	Sump #6
11	Plant 1	Boiler Condensate Run-Off	34	Cooling Tower	Cooling Tower Sump
12	Plant 2	Waste Accumulation Area	35A	Admin	Septic Tank/French Drains East of Administration Building
13	Plant 2	Former RCRA Greater than 90 Day Storage Area	35B	Plant 1	Septic Tank/French Drains Northwest of Plant 1
14	Plant 2	Waste Compactor and Scrap Metal Area	35C	Plant 1	Septic Tank/French Drains West of Plant 1
15	Plant 2	Distillate Wastewater Tank 2	35D	Plant 1	Septic Tank/French Drains Southwest of Plant 1
16	Plant 2	Reactor 4 Knockout Tank	35E	Plant 2	Septic Tank/French Drains Southwest of Plant 2
17	Plant 2	Dimethylformamide (DMF) pump overflow	35F	Pilot Plant	Septic Tank/French Drains Northwest of Pilot Plant
18	Plant 2	Plant 2 Hexandiol Tank	35G	Admin	Septic Tank/French Drains South of Administration Building
19	Plant 2	Fume Incinerator	36	Admin	Admin Building Closed Laboratory Storage Area
20	Plant 3	RCRA Less Than 90 Day Storage Unit	37	Plant 2	DOA Sump
21A	Warehouse	Adipic Acid Silos	38	Plant 2	Exterior Trench
21B	Plant 3	Adipic Acid Silos	39	Plant 1	Electrical Transformers
22	Plant 3	Tote Storage Area	40	Plant 3	Trench System
23	Plant 3	Non-hazardous Waste Accumulation	41	Plant 1	Stained Concrete in Warehouse
24	Tank Farm	Transfer Station for the Tank Farm	42	Plant 1	Center Trench
25	Pilot Plant	Former Soil Pile Area removed from AOC 10	43	Plant 1	Sump In Foundation, NE End of Plant
27A	Shipping/Receiving	Non-hazardous, off-spec, damaged product and Raw Material Storage	44	Plant 1	Sump In Foundation, SE End of Plant
27B	Shipping/Receiving	Non-hazardous, off-spec, damaged product and Raw Material Storage	45	Pilot Plant	Sump In NW Corner of Plant (interior and exterior)
27C	Shipping/Receiving	Non-hazardous, off-spec, damaged product and Raw Material Storage	46	Plant 2	Scale Area and Circular Plate Area in Foundation
27D	Shipping/Receiving	Non-hazardous, off-spec, damaged product and Raw Material Storage	47	Plant 2	Trench System and Sump Leading to Sump 4
27E	Shipping/Receiving	Non-hazardous, off-spec, damaged product and Raw Material Storage	48	Plant 1	Empty Drum Storage at NW End of Warehouse
27F	Shipping/Receiving	Non-hazardous, off-spec, damaged product and Raw Material Storage	49	Pilot Plant	Trench around East Wall

**LEGEND**

- LIGHT POLE
- ⊠ CATCHBASIN
- ⊙ UNKNOWN VALVE
- FIRE HYDRANT
- MW MONITORING WELL
- ⊙ DRAINAGE MANHOLE
- ROOF DRAIN LOCATION
- ⊕ SOIL SAMPLE LOCATION
- CORE SAMPLE LOCATION
- SEPTIC TANK
- LEACH PIT
- AOC BOUNDARY
- - - APPROXIMATE AOC BOUNDARY
- ▨ HISTORIC AND CLOSED AOC AREA
- ▨ AOC AREAS CURRENTLY BEING ADDRESSED BY OTHERS
- WILL REQUIRE SOME FOLLOW-UP

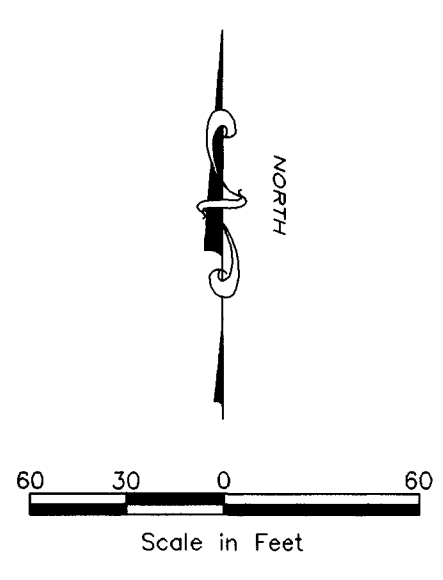

**FIGURE 1-2**  
**AREA OF CONCERN MAP**  
 BAYER  
 HICKSVILLE POLYMER PLANT

SCALE:	DATE:	PROJECT NUMBER:
AS SHOWN	02/14/03	4690-079

**ENSR**  
 INTERNATIONAL  
 20 NEW ENGLAND AVENUE  
 PISCATAWAY, NEW JERSEY 08854  
 PHONE: (732) 981-0200  
 FAX: (732) 981-0116  
 WEB: HTTP://WWW.ENSR.COM

DESIGNED BY:	NO.:	DESCRIPTION:	DATE:	BY:
CC				
DRAWN BY:				
/jk				
CHECKED BY:				
APPROVED BY:				

SHEET NUMBER:  
 1 of 1

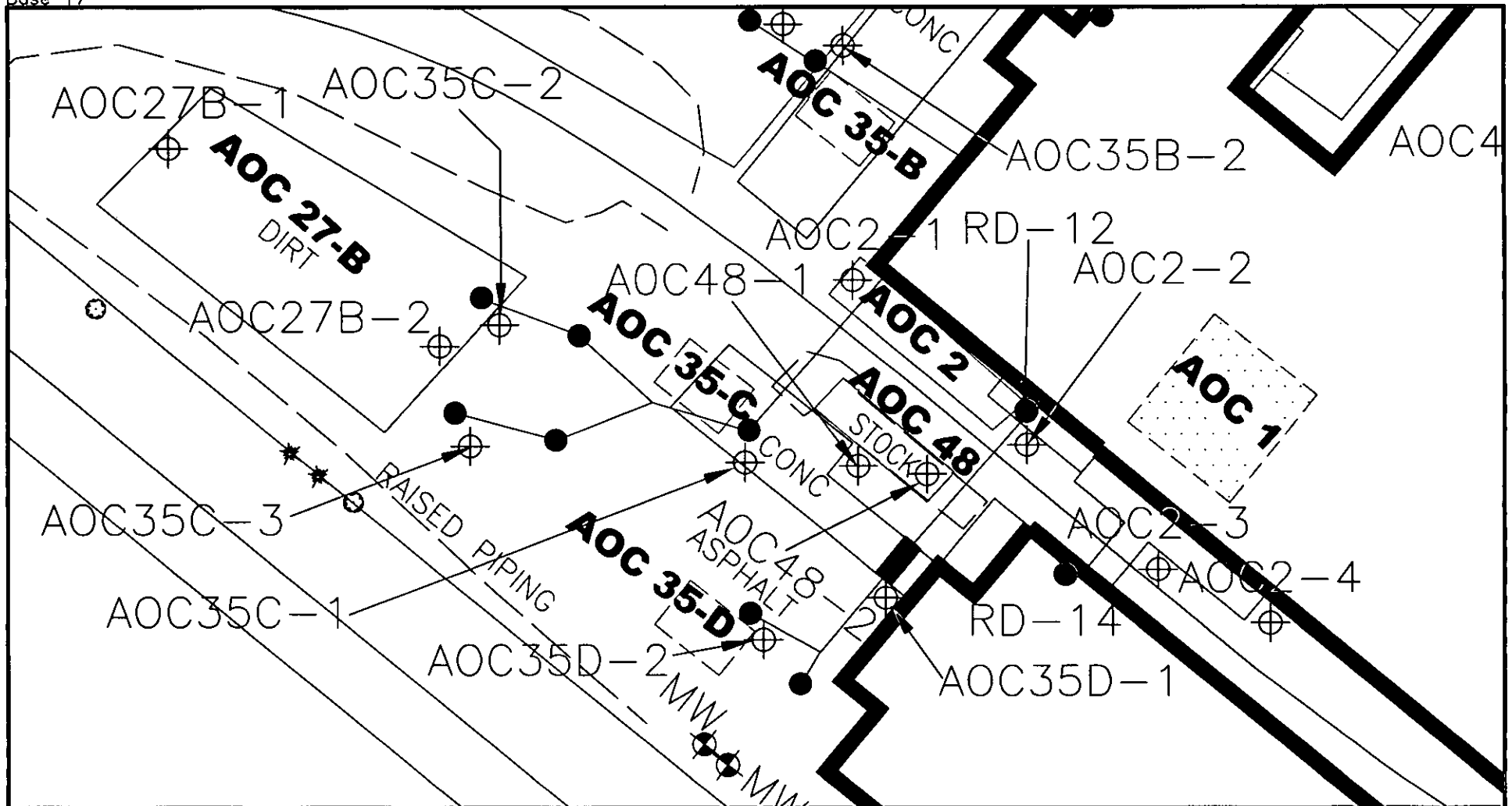
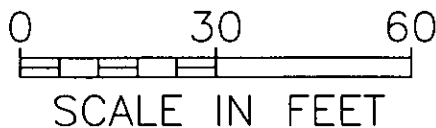

FIGURE 2-1



- LEGEND:**
- SEPTIC TANK
  - LEACH PIT
  - ROOF DRAIN LOCATION
  - ⊕ SOIL SAMPLE LOCATION
  - CORE SAMPLE LOCATION
  - AOC BOUNDARY
  - - - APPROXIMATE AOC BOUNDARY

**ENSR.**  
INTERNATIONAL

BAYER HICKSVILLE POLYMER PLANT  
PROPOSED SAMPLING LOCATIONS  
AOC 1, AOC 2, AOC 27B, AOC 35C, AOC 35D, AOC 48  
RFI/RFA WORK PLAN

Drawn:	KLP	Date:	03/19/03	Project Number:		Rev.	
Appr'd:	CG	Revised:	X	4690-079-009		A	



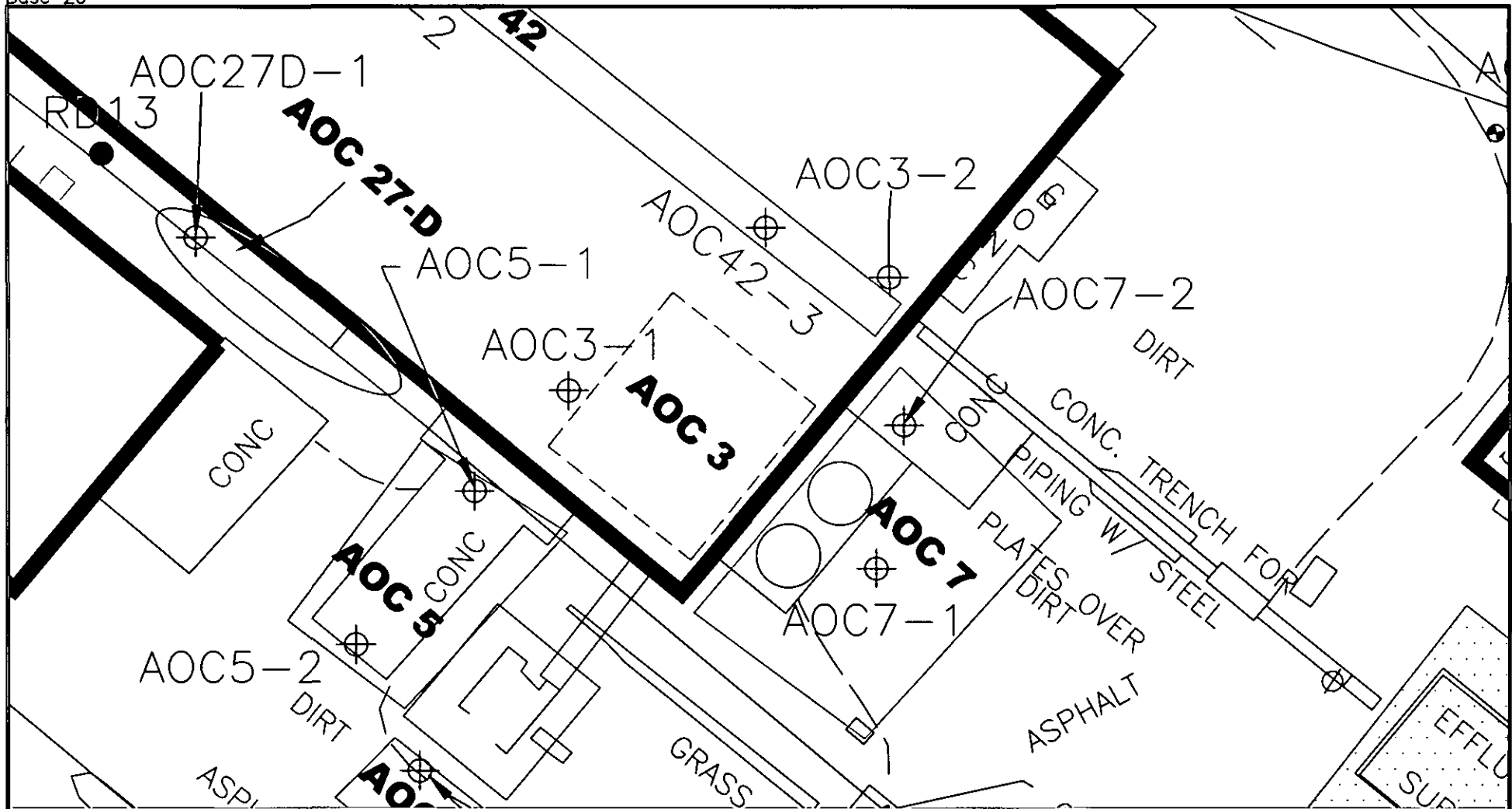
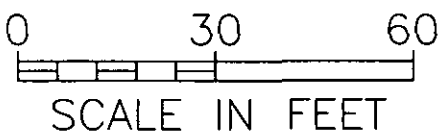

FIGURE 2-2



- LEGEND:**
- ROOF DRAIN LOCATION
  - ⊕ SOIL SAMPLE LOCATION
  - CORE SAMPLE LOCATION
  - AOC BOUNDARY
  - - - APPROXIMATE AOC BOUNDARY



**BAYER HICKSVILLE POLYMER PLANT  
PROPOSED SAMPLING LOCATIONS  
AOC 3, AOC 5, AOC 7 & AOC 27D  
RFI/RFA WORK PLAN**

Drawn: KLP	Date: 03/19/03	Project Number: 4690-079-009	Rev. A
Appr'd: CG	Revised: X		

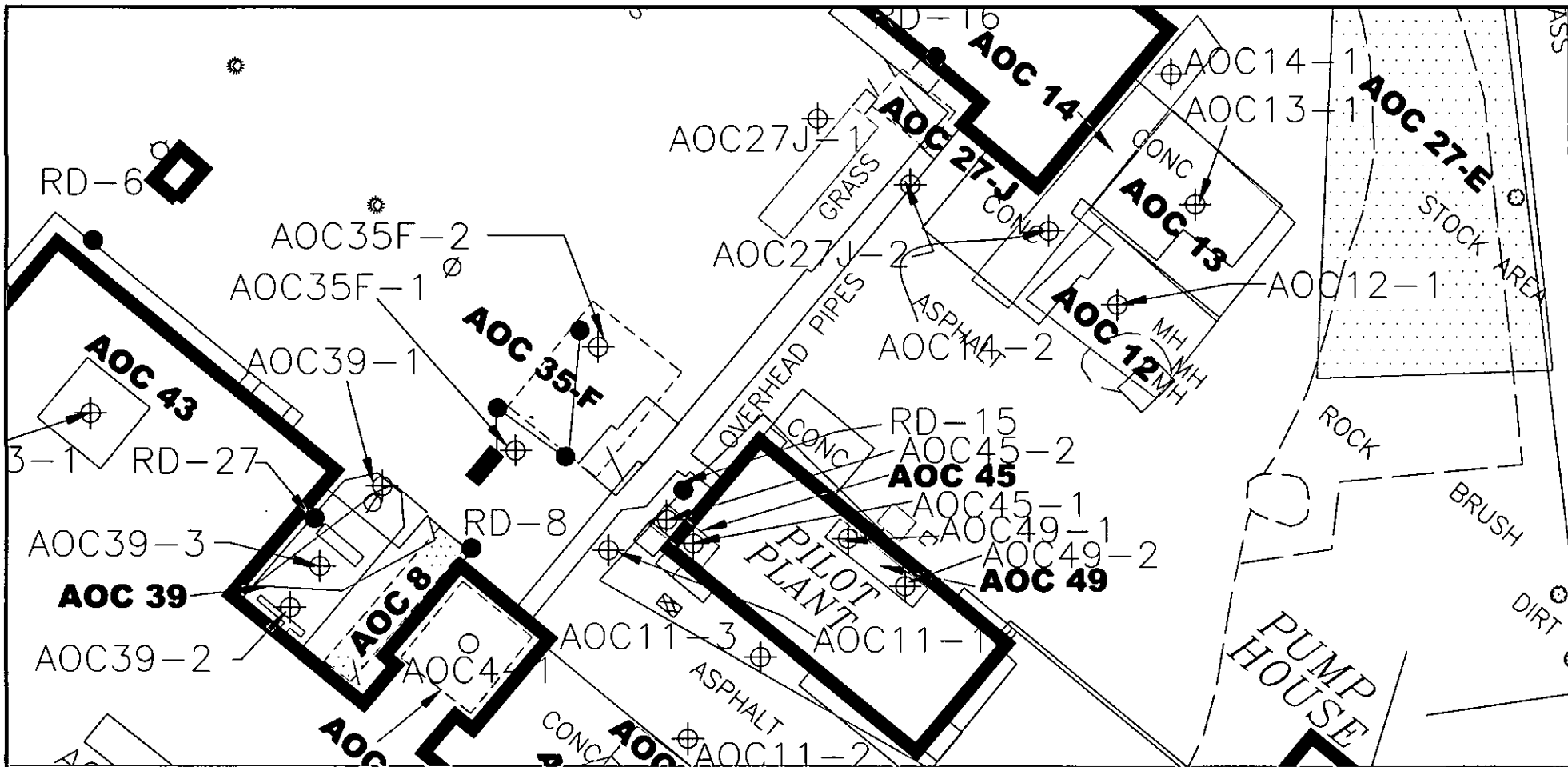
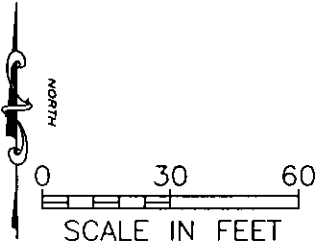

FIGURE 2-3

Base 15



- LEGEND:**
- SEPTIC TANK
  - LEACH PIT
  - ROOF DRAIN LOCATION
  - ⊕ SOIL SAMPLE LOCATION
  - CORE SAMPLE LOCATION
  - AOC BOUNDARY
  - - - APPROXIMATE AOC BOUNDARY

**ENSR.**  
INTERNATIONAL

**BAYER HICKSVILLE POLYMER PLANT  
PROPOSED SAMPLE LOCATIONS**

AOC 4, AOC 8, AOC 12, AOC 13, AOC 14, AOC 27E, AOC 27J  
AOC 35E, AOC 35F, AOC 39, AOC 43, AOC 45 & AOC 49  
RFI/RFA WORK PLAN

Drawn: KLP	Date: 03/19/03	Project Number:	Rev.
App'd: CG	Revised: X	4690-079-009	A

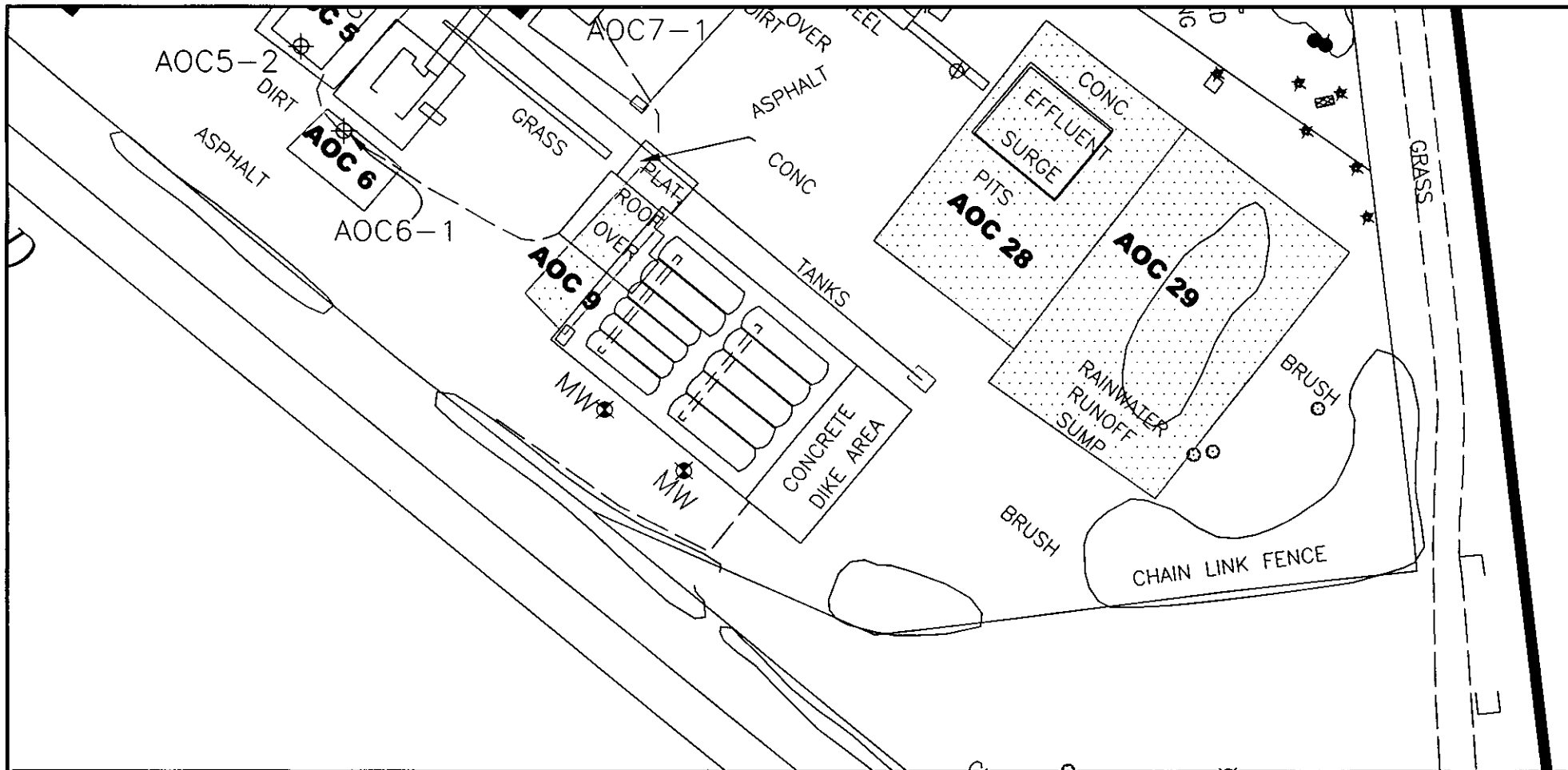
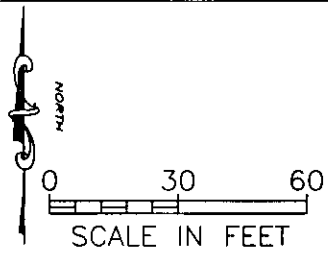

FIGURE 2-4

Base 23



- LEGEND:**
- ROOF DRAIN LOCATION
  - ◆ SOIL SAMPLE LOCATION
  - CORE SAMPLE LOCATION
  - AOC BOUNDARY
  - - - APPROXIMATE AOC BOUNDARY

**ENSR.**  
INTERNATIONAL

**BAYER HICKSVILLE POLYMER PLANT  
PROPOSED SAMPLING LOCATIONS  
AOC 6, AOC 9, AOC 28 & AOC 29  
RFI/RFA WORK PLAN**

Drawn: KLP	Date: 03/19/03	Project Number:	Rev.
Appr'd: CG	Revised: X	4690-079-009	A

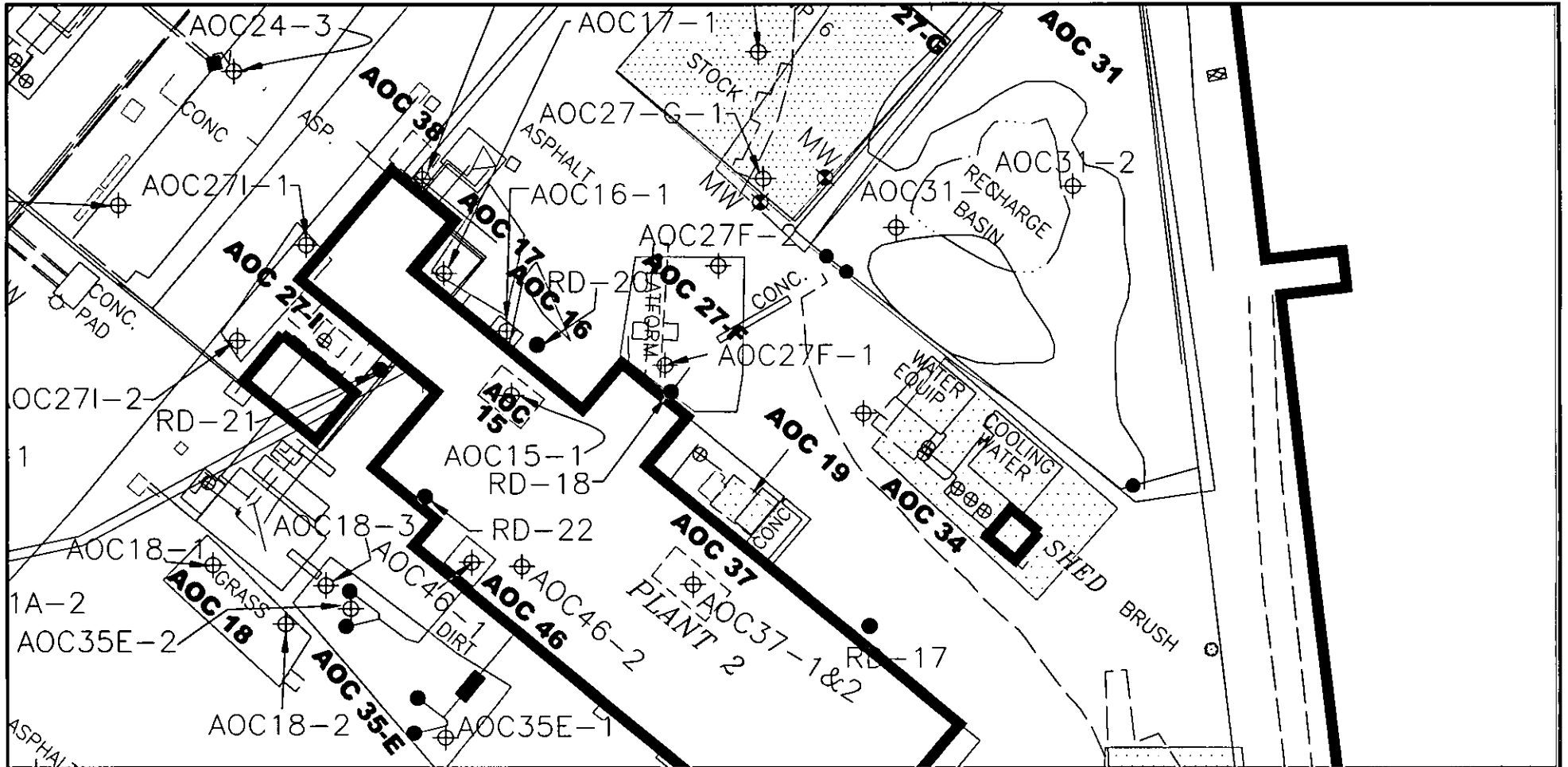
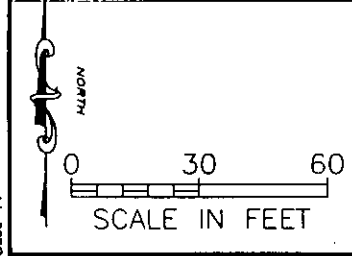

FIGURE 2-5



- LEGEND:**
- SEPTIC TANK
  - LEACH PIT
  - ROOF DRAIN LOCATION
  - ◆ SOIL SAMPLE LOCATION
  - CORE SAMPLE LOCATION
  - AOC BOUNDARY
  - - - APPROXIMATE AOC BOUNDARY

**ENSR**  
INTERNATIONAL

**BAYER HICKSVILLE POLYMER PLANT  
PROPOSED SAMPLING LOCATIONS**  
AOC 15, AOC 16, AOC 17, AOC 18, AOC 19  
AOC 27F, AOC 31, AOC 34 & AOC 46  
RFI/RFA WORK PLAN

Drawn: KLP	Date: 03/19/03	Project Number:	Rev.
App'd: CG	Revised: X	4690-079-009	A

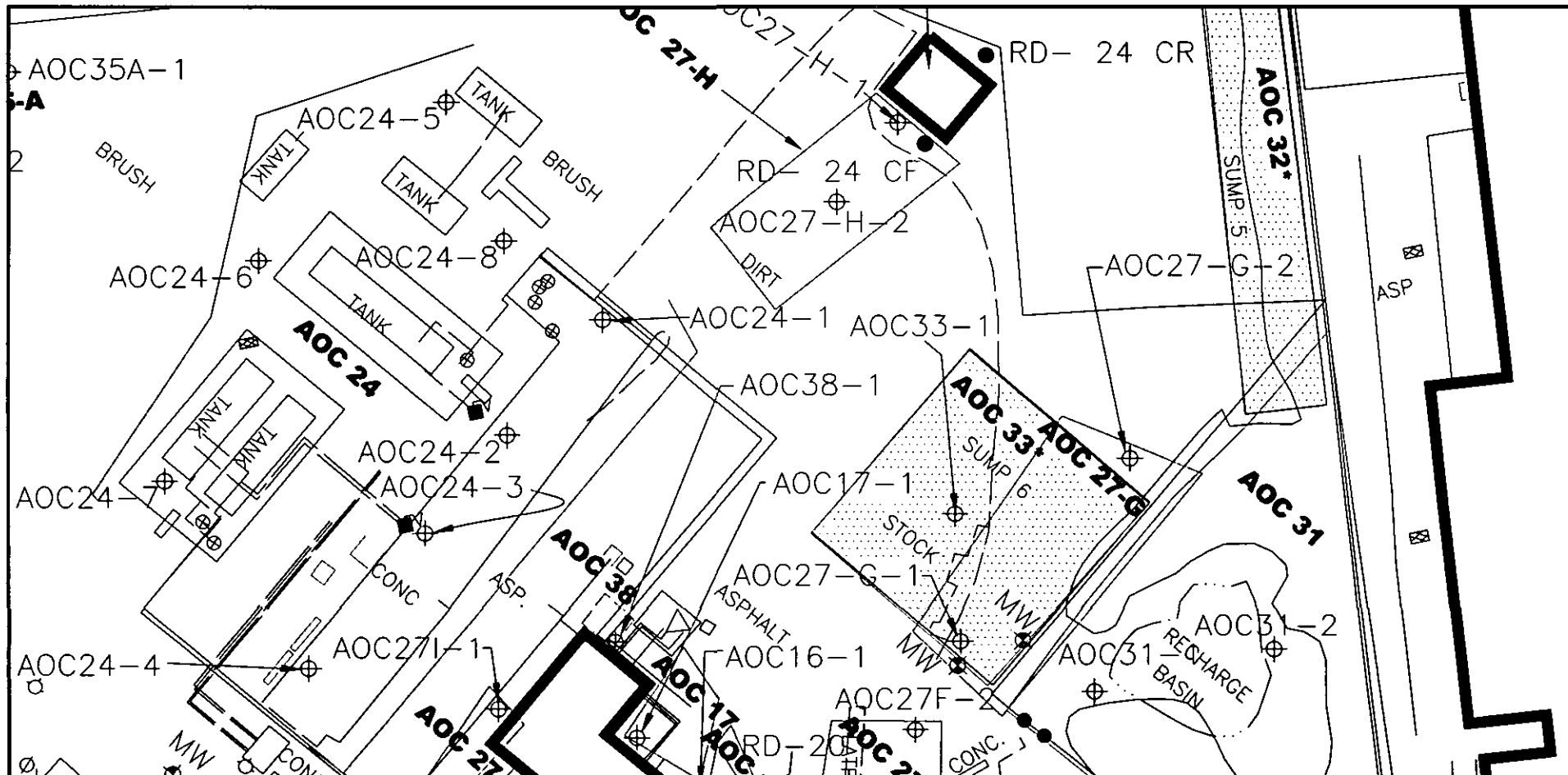
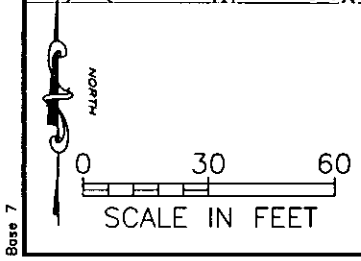

FIGURE 2-6



**LEGEND:**  
 ● ROOF DRAIN LOCATION  
 ◆ SOIL SAMPLE LOCATION  
 ○ CORE SAMPLE LOCATION  
 — AOC BOUNDARY  
 - - - APPROXIMATE AOC BOUNDARY

**ENSR**  
 INTERNATIONAL

**BAYER HICKSVILLE POLYMER PLANT  
 PROPOSED SAMPLING LOCATIONS**  
 AOC 17, AOC 24, AOC 27G, AOC 27H, AOC 31 & AOC 33  
 RFI/RFA WORK PLAN

Drawn: KLP	Date: 03/19/03	Project Number:	Rev:
Appr'd: CG	Revised: X	4690-079-009	A

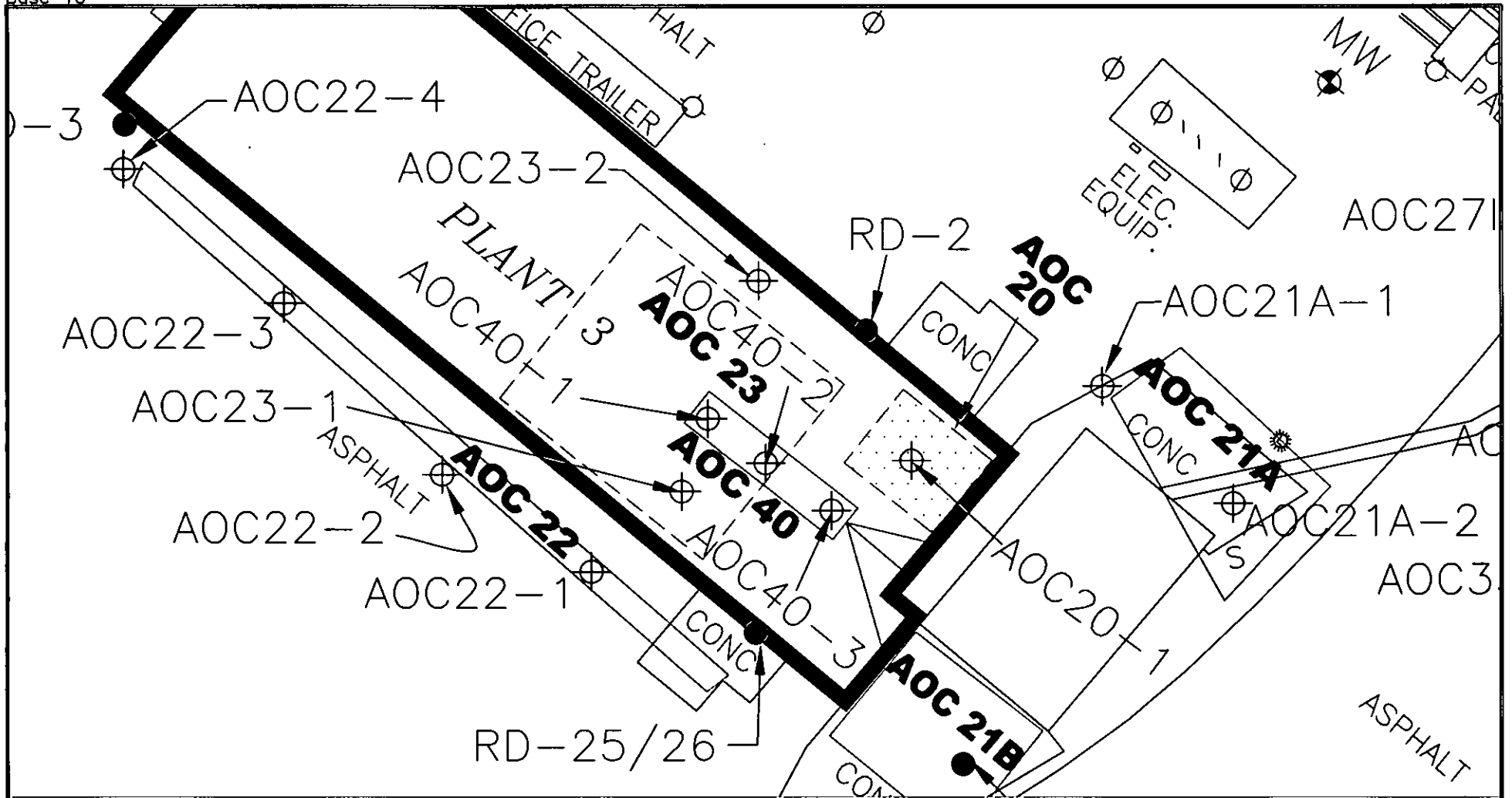
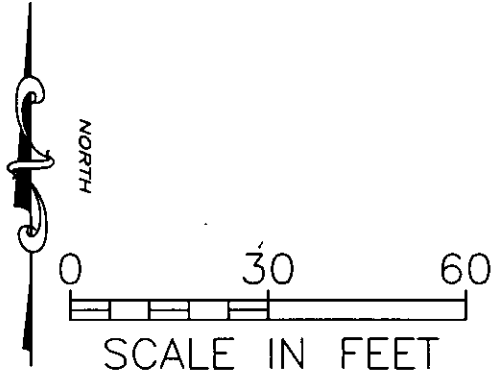

FIGURE 2-7



- LEGEND:**
- ROOF DRAIN LOCATION
  - ⊕ SOIL SAMPLE LOCATION
  - CORE SAMPLE LOCATION
  - AOC BOUNDARY
  - - - APPROXIMATE AOC BOUNDARY



**BAYER HICKSVILLE POLYMER PLANT  
PROPOSED SAMPLING LOCATIONS  
AOC 20, AOC 21A, AOC 22, AOC 23 & AOC 40  
RFI/RFA WORK PLAN**

Drawn:	KLP	Date:	03/19/03	Project Number:		Rev.	
Appr'd:	CG	Revised:	X	4690-079-009		A	

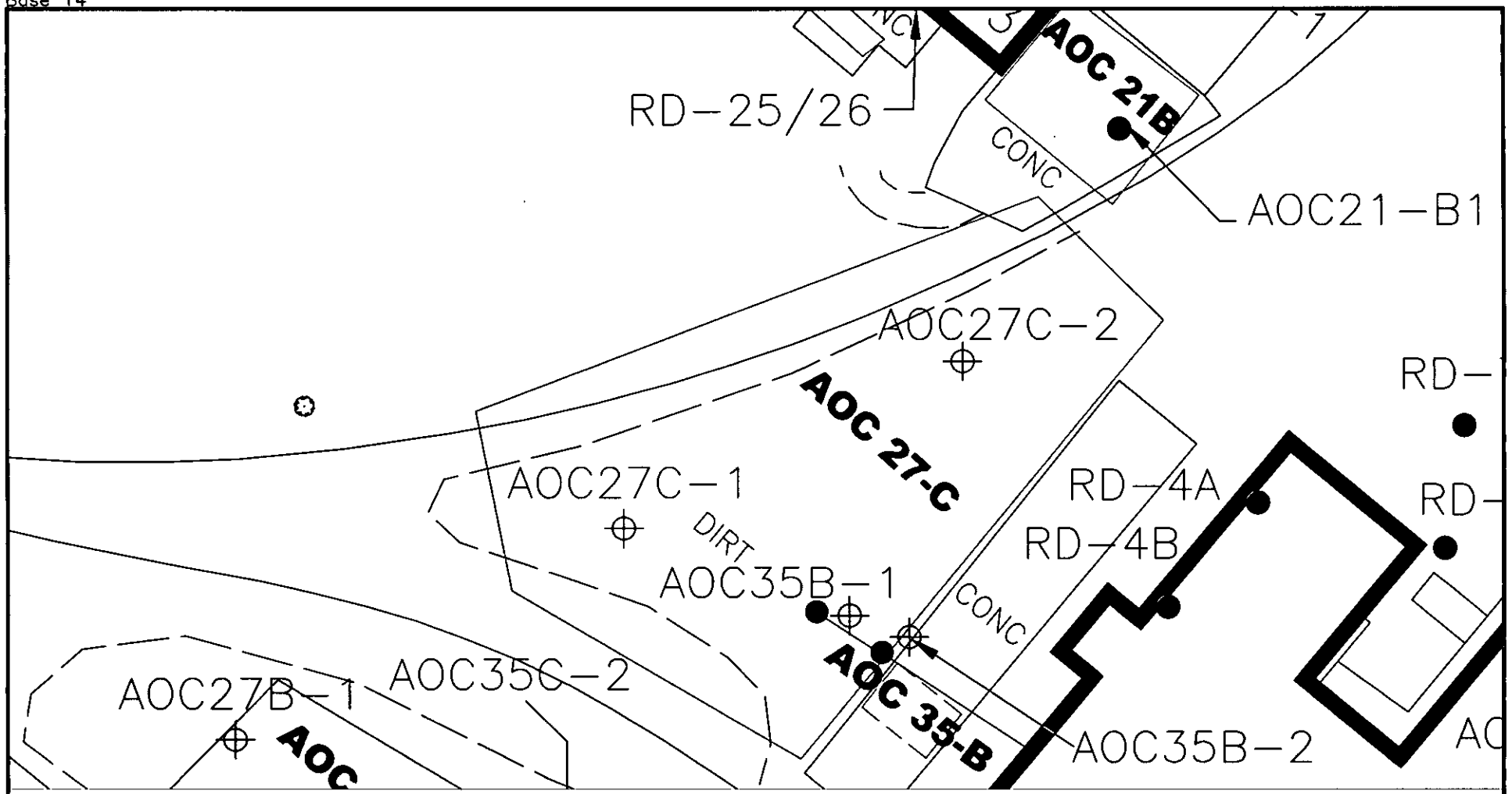
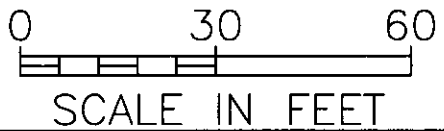

FIGURE 2-8



- LEGEND:**
- SEPTIC TANK
  - LEACH PIT
  - ROOF DRAIN LOCATION
  - ⊕ SOIL SAMPLE LOCATION
  - CORE SAMPLE LOCATION
  - AOC BOUNDARY
  - - - APPROXIMATE AOC BOUNDARY



**BAYER HICKSVILLE POLYMER PLANT  
PROPOSED SAMPLING LOCATIONS  
AOC 21B, AOC 27C & AOC 35B  
RFI/RFA WORK PLAN**

Drawn:	KLP	Date:	03/19/03	Project Number:	4690-079-009	Rev.	
Appr'd:	CG	Revised:	X				A

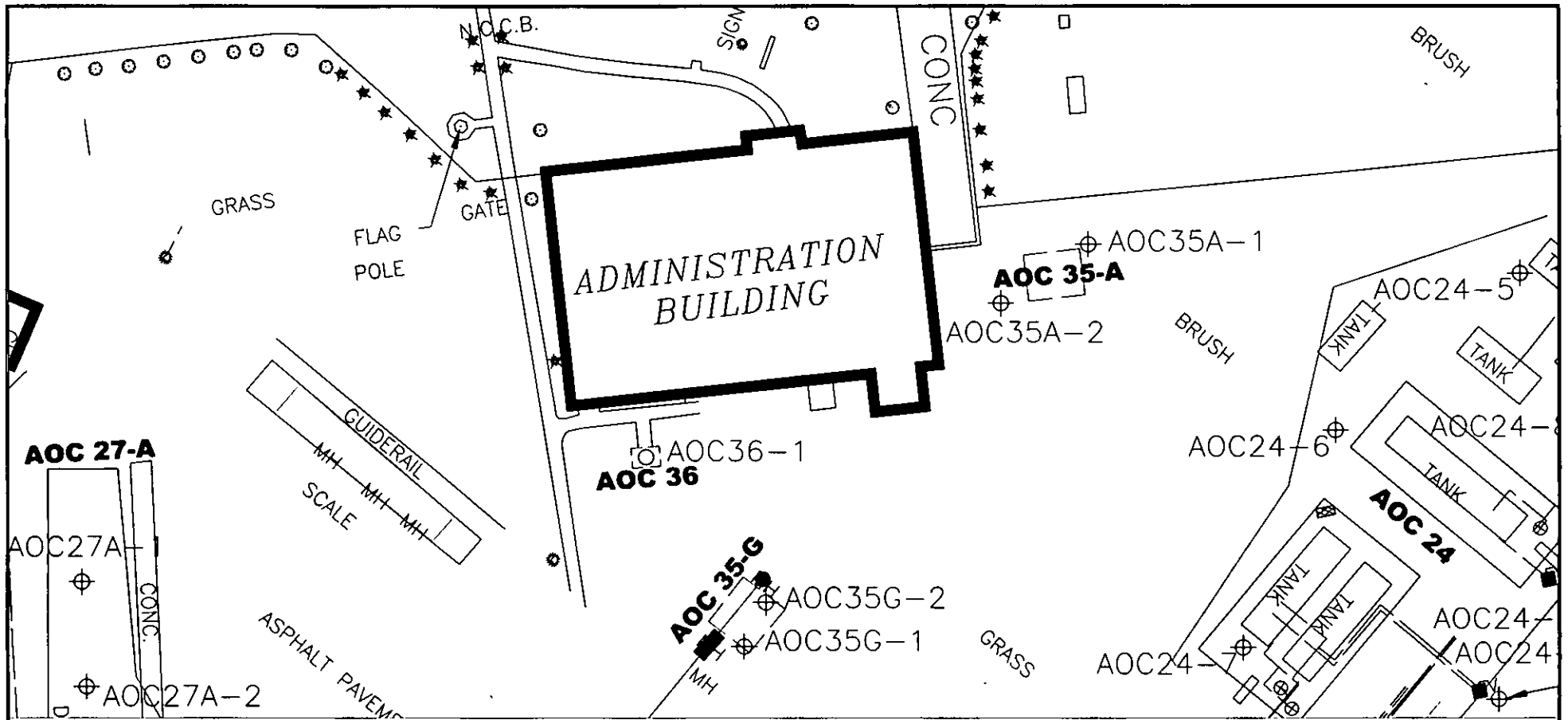

FIGURE 2-9

**ENSR**  
INTERNATIONAL

**BAYER HICKSVILLE POLYMER PLANT  
PROPOSED SAMPLING LOCATIONS  
AOC 27A, AOC 35A, AOC 35G & AOC 36  
RFI/RFA WORK PLAN**

Drawn: KLP	Date: 03/19/03	Project Number:	Rev:
App'd: CG	Revised: X	4690-079-009	A

- LEGEND:**
- SEPTIC TANK
  - LEACH PIT
  - ROOF DRAIN LOCATION
  - ◆ SOIL SAMPLE LOCATION
  - CORE SAMPLE LOCATION
  - APPROXIMATE AOC BOUNDARY

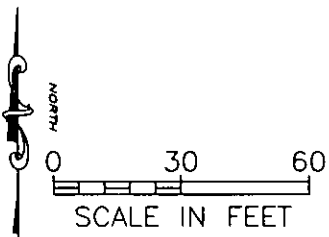



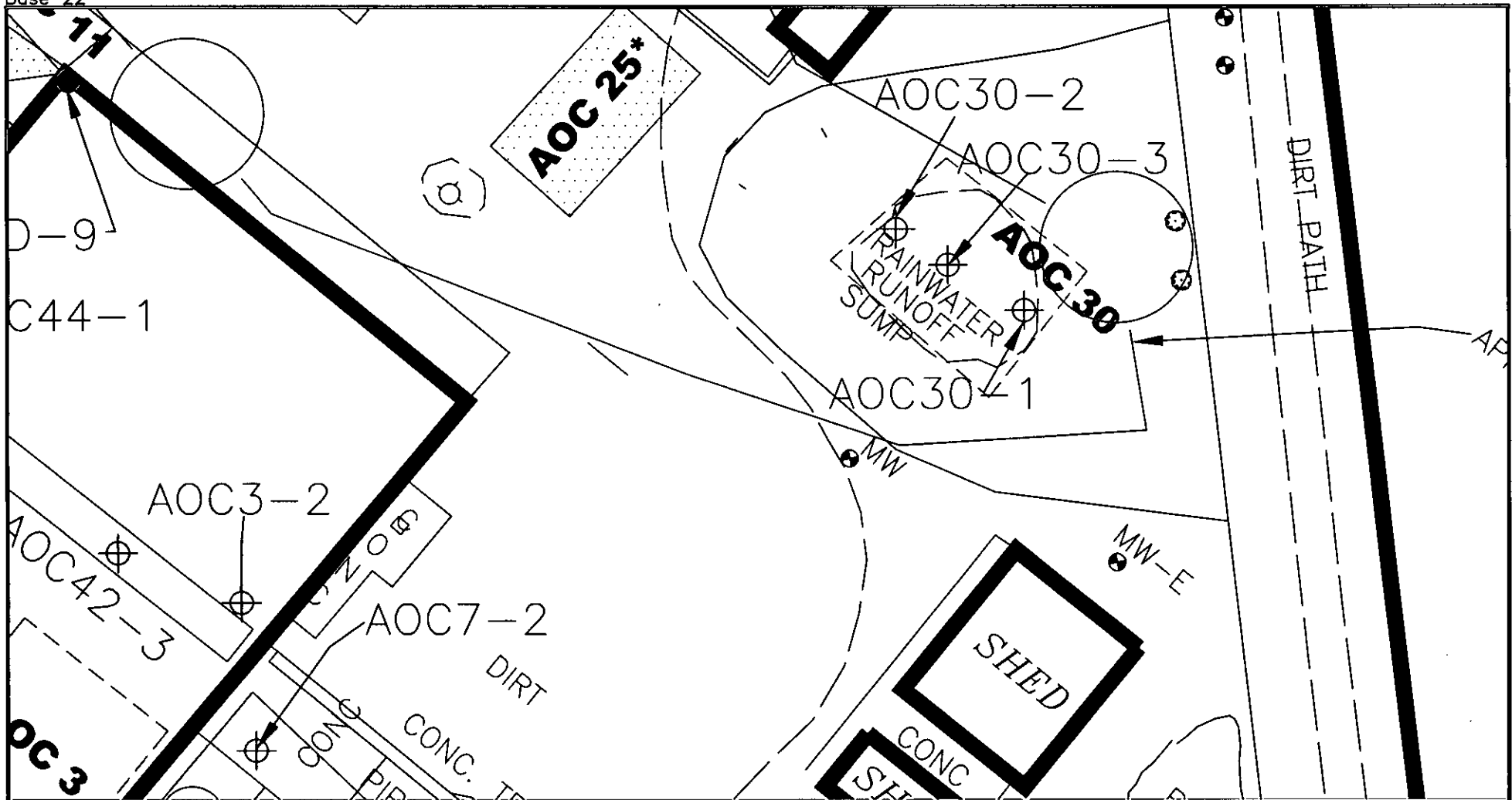
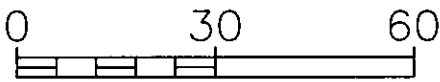

FIGURE 2-10



SCALE IN FEET

**LEGEND:**

- ROOF DRAIN LOCATION
- ⊕ SOIL SAMPLE LOCATION
- CORE SAMPLE LOCATION
- AOC BOUNDARY
- - - APPROXIMATE AOC BOUNDARY

**ENSR.**  
INTERNATIONAL

**BAYER HICKSVILLE POLYMER PLANT  
PROPOSED SAMPLING LOCATIONS  
AOC 25 & AOC 30  
RFI/RFA WORK PLAN**

Drawn:	KLP	Date:	03/19/03	Project Number:		Rev.	
Appr'd:	CG	Revised:	X	4690-079-009		A	

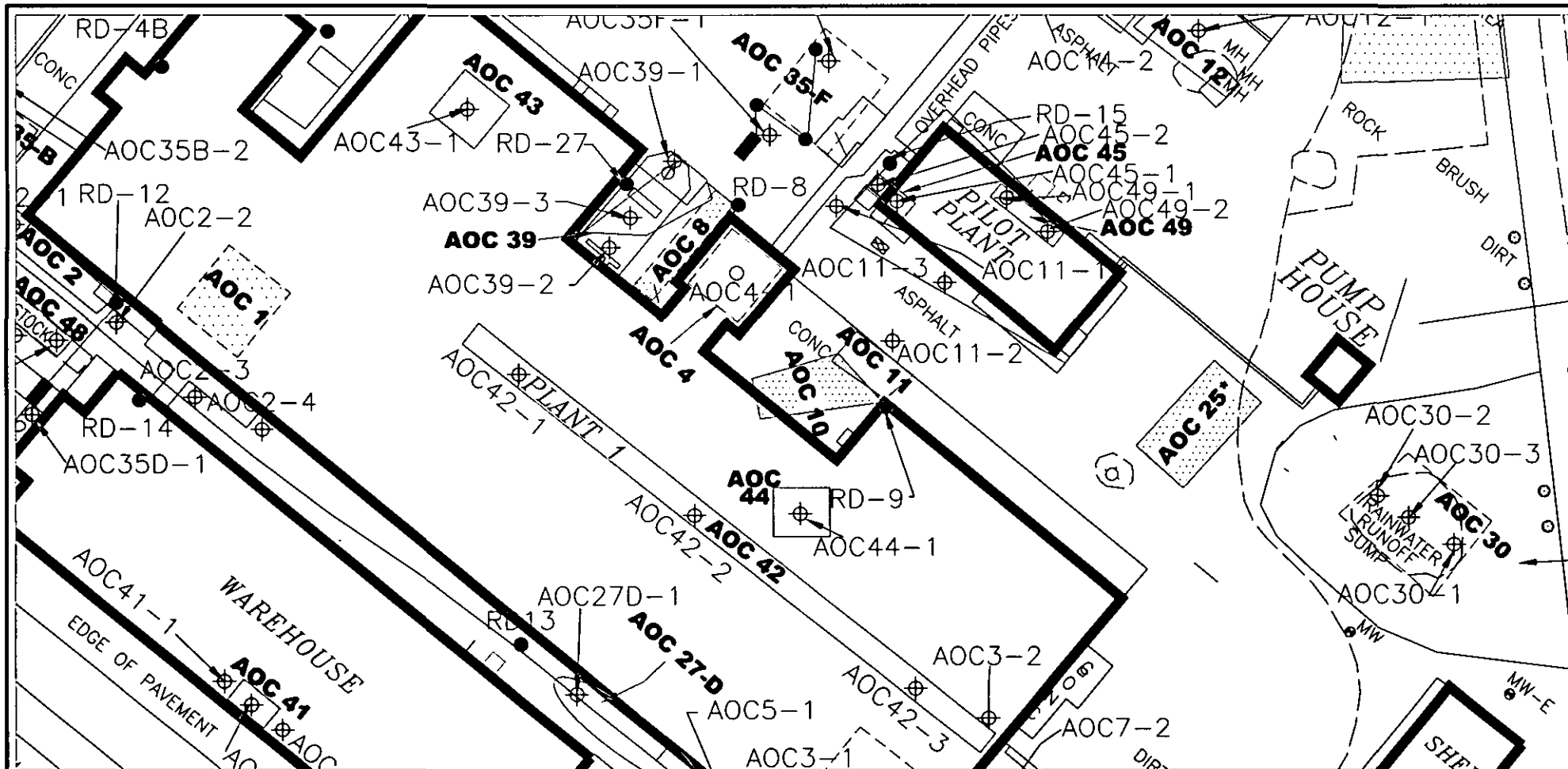
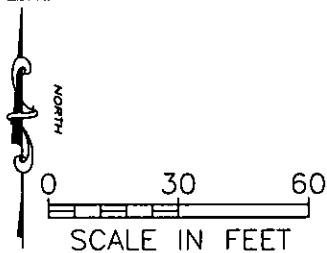

FIGURE 2-11

Base 23



- LEGEND:**
- ROOF DRAIN LOCATION
  - ⊕ SOIL SAMPLE LOCATION
  - CORE SAMPLE LOCATION
  - AOC BOUNDARY
  - - - APPROXIMATE AOC BOUNDARY

**ENSR.**  
INTERNATIONAL

**BAYER HICKSVILLE POLYMER PLANT  
PROPOSED SAMPLING LOCATIONS**  
AOC 5, AOC 10, AOC 11,  
AOC 41, AOC 42 & AOC 44  
RFI/REA WORK PLAN

Drawn: KLP	Date: 03/19/03	Project Number:	Rev.
App'd: CG	Revised: X	4690-079-009	A

**Figure 5-1  
Draft RFA/RFI Investigation Schedule  
Bayer Hicksville Polymer Plant**

Activity	Week 1	Week 2	Week 3	Week 4	Week 5	Week 6	Week 7	Week 8	Week 9	Week 10	Week 11	Week 12	Week 13	Week 14	Week 15
Notice to Proceed	[Shaded]														
Contractor Procurement and Mobilization	[Shaded]														
Surface Soil Sampling	[Shaded]														
Concrete Core Sampling	[Shaded]														
Geoprobe Subsurface Soil Sampling	[Shaded]														
Laboratory Analyses	[Shaded]														
Report Preparation	[Shaded]														
Report Submission	[Shaded]														

**APPENDICES**

---

**APPENDIX A**

**Superfund Fact Sheet**

---

# HOOKER CHEMICAL/ RUCO POLYMER NEW YORK

EPA ID# NYD002920312



**EPA REGION 2**  
**CONGRESSIONAL DIST. 03**  
Nassau County  
Hicksville

**Other Names:**  
Ruco Polymer Corp.

## Site Description

---

The Hooker Chemical/Ruco Polymer site, located in an industrial park area of Hicksville on Long Island, has been used to manufacture plastics, latex, and esters since 1945. Liquid process wastes were discharged into sand sumps from 1951 to 1975. The sand sumps for Plant 2, which manufactured polyvinyl chloride (PVCs) and latex, received approximately 2 million gallons of process wastewater per year from 1956 to 1975. In addition, unknown amounts of styrene and butadiene were discharged from the latex processing. Reportedly, the dry well for Plant 1, used for the manufacture of esters, received wastewater containing mixed glycols and alcohols. Currently, only cooling water is disposed of on site, while other wastes are sent off site for disposal. Some glycol wastes are incinerated on site. Numerous leaks and spills of chemicals, including polychlorinated biphenyls (PCBs), have occurred, and solidified latex materials are buried on site. Waste disposal and chemical spillage also have occurred at the adjacent Grumman Aerospace Corporation Plant that is being addressed by the New York State Department of Environmental Conservation (NYSDEC) and the U.S. Navy. The 14-acre Ruco Polymer plant site is fenced, and contaminated areas are accessible to only a few of the 90 employees at the facility. Approximately 20,000 people live within a mile of the site. There are four public water supply wells within a mile of the site and 24 wells within 3 miles.

## Site Responsibility:

This site is being addressed through Federal, State and potentially responsible parties' actions.

### NPL LISTING HISTORY

Proposed Date: 10/01/84

Final Date: 06/01/86

## Threats and Contaminants

---



Groundwater underlying the site is contaminated with organic compounds such as vinyl chloride, trichloroethylene (TCE) perchloroethylene (PCE) and tentatively identified compounds (TICs). Several industrial wells located downgradient from the site are contaminated with vinyl chloride.

On-site soils contain volatile organic compounds (VOCs) and semi-volatile organic



compounds (SVOCs). The greatest potential health risk is to people who eat, drink, inhale, or come into direct contact with contaminants during domestic use of groundwater.

## Cleanup Approach

---

EPA has designated three operable units for the Site. Operable Unit 1 (OU-1) addresses contaminated soils at the Hooker/Ruco Facility. Operable Unit 2 (OU-2) addresses polychlorinated biphenyl (PCB) contaminated surface soils. Operable Unit 3 (OU-3), addresses the downgradient commingled contaminated groundwater plume beyond the Hooker/Ruco Facility and also the contaminated groundwater beneath the Hooker/Ruco Facility.

## Response Action Status

---



**PCB-Contaminated Soils:** Based on a potentially responsible party's (PRP's) study to address the PCB-contaminated soils, in 1990 EPA issued a Record of Decision (ROD) to excavate and remove all PCB-contaminated soils OU-2. This action was conducted by the potentially responsible parties under an Administrative Order issued by EPA and was completed in 1992.



**Ruco Facility:** In 1988, the EPA signed a Consent Order with the PRPs to conduct a study to determine the nature and extent of site contamination and to evaluate alternatives for final cleanup. In January 1994, based on the results of this study, EPA issued a Record of Decision for OU-1 for the Ruco facility which includes additional soil sampling, possible excavation of shallow soils in limited areas, soil flushing in one and possibly two sumps, and control of contaminated groundwater beneath the Ruco facility. In June 1994, EPA issued a Unilateral Administrative Order directing the PRPs to perform the Remedial Design and Remedial Action (RD/RA). Actions on this site are being coordinated with the actions taken on the adjoining Northrop/Grumman (Northrop) and Naval Weapons Industrial Weapons Reserve Plant (NWIRP) sites. The groundwater beneath the Hooker/Ruco Site is commingled with the downgradient contaminated groundwater beneath the Northrop and NWIRP sites. Although groundwater contamination was included under the 1994 ROD, due to the commingling of groundwater with groundwater contamination from Northrop and NWIRP, the groundwater contamination for the Hooker Ruco Site is being addressed under OU-3 (downgradient commingled contaminated groundwater plume beyond the Hooker/Ruco Facility and also the contaminated groundwater beneath the Hooker/Ruco Facility). The remedial actions performed for the unsaturated soil component of OU-1 consisted of: the excavation and off-site disposal of 310 tons of PCB contaminated soil; removal and off-site disposal of the concrete tank in Sump 1 and the installation of a soil flushing system on sump one to *enhance the migration of the remaining minimal chemical presence from the unsaturated soils to the groundwater*. The soil flushing system is expected to be operational by the end of 2002. The groundwater will be addressed in turn by the OU-3 remedy.



**Downgradient Groundwater:** In September 2000 based on the RI/FS, EPA issued an OU-3 ROD for the site that includes the remediation of a distinct plume of groundwater contaminated with vinyl chloride, the primary contaminant at the site, using an innovative treatment system called "biosparging". Biosparging is a form of bioremediation that

involves the introduction of air/oxygen into the aquifer to enhance the natural breakdown of the vinyl chloride in the groundwater. This treatment system will operate in addition to the groundwater treatment systems that are already operating under NYSDEC authority to effectively remove a mix of VOCs emanating from the sites. In April 2001, EPA issued an Administrative Order directing the PRPs for the Hooker Chemical/Ruco Polymer Site to perform the Remedial Design and Remedial Action for the September 2000 ROD. In May 2001, the PRPs for the Hooker Ruco Site responded with their intent to comply with the terms of the Administrative Order. The PRPs are currently performing predesign investigative field activities in support of the selected remedy (i.e., biosparging.)

## Cleanup Progress



---

After listing the Hooker Chemical/Ruco site on the NPL, the EPA determined that no immediate actions were required to reduce threats to the public or the environment. An early action, taken to address the PCB contaminated soil, has eliminated the potential for exposure. 3,230 tons (1,957 yd<sup>3</sup>) of soils with PCB concentrations from 10-500 ppm were sent to an off-site landfill. 85.2 tons (52 yd<sup>3</sup>) of soils with PCB concentrations greater than 500 ppm were sent to an off-site incinerator.

## Site Repository



---

Hicksville Public Library, 169 Jerusalem Avenue, Hicksville, NY 11801



**APPENDIX B**

**SWMU/AOC Closure Documentation**

---

**Environmental Testing Laboratories, Inc.**  
**208 Route 109, Farmingdale, New York 11735**  
**Phone - 631-249-1456 Fax - 631-249-8344**

<b>P8258</b>			
<b>Project: Bayer Corp.</b>			
<b>Address: 125 New South Rd., Hicksville, NY</b>			
<b>Collected Date:</b>			<b>01/27/03</b>
	<b>Sample Type:</b>		<b>Grab</b>
<b>Analysis</b>	<b>Analyte</b>	<b>Units</b>	<b>Rinse AOC 20/1</b>
<b>PCB Aroclors by SW-846 8082</b>	<b>PCB 1016</b>	<b>ppb</b>	<b>&lt;0.16</b>
<b>PCB Aroclors by SW-846 8082</b>	<b>PCB 1221</b>	<b>ppb</b>	<b>&lt;0.060</b>
PCB Aroclors by SW-846 8082	PCB 1232	ppb	<0.22
PCB Aroclors by SW-846 8082	PCB 1242	ppb	<0.22
PCB Aroclors by SW-846 8082	PCB 1248	ppb	<0.18
PCB Aroclors by SW-846 8082	PCB 1254	ppb	<0.080
PCB Aroclors by SW-846 8082	PCB 1260	ppb	<0.16
Semivolatile Compounds - EPA 8270C	Phenol	ppb	9.80
Semivolatile Compounds - EPA 8270C	bis(2-Chloroethyl)ether	ppb	<0.80
Semivolatile Compounds - EPA 8270C	2-Chlorophenol	ppb	<1.42
Semivolatile Compounds - EPA 8270C	1,3-Dichlorobenzene	ppb	<1.26
Semivolatile Compounds - EPA 8270C	1,4-Dichlorobenzene	ppb	<1.18
Semivolatile Compounds - EPA 8270C	Benzyl alcohol	ppb	0.88
Semivolatile Compounds - EPA 8270C	1,2-Dichlorobenzene	ppb	<1.34
Semivolatile Compounds - EPA 8270C	2-Methylphenol	ppb	0.76
Semivolatile Compounds - EPA 8270C	bis(2-Chloroisopropyl)ether	ppb	<1.28
Semivolatile Compounds - EPA 8270C	3,4-Methylphenol	ppb	1.70
Semivolatile Compounds - EPA 8270C	N-Nitroso-di-n-propylamine	ppb	<1.10
Semivolatile Compounds - EPA 8270C	Hexachloroethane	ppb	<1.70
Semivolatile Compounds - EPA 8270C	Nitrobenzene	ppb	<1.80
Semivolatile Compounds - EPA 8270C	Isophorone	ppb	<1.66
Semivolatile Compounds - EPA 8270C	2-Nitrophenol	ppb	<1.48
Semivolatile Compounds - EPA 8270C	2,4-Dimethylphenol	ppb	0.94
Semivolatile Compounds - EPA 8270C	Benzoic acid	ppb	<3.04
Semivolatile Compounds - EPA 8270C	bis(2-Chloroethoxy)methane	ppb	<1.34
Semivolatile Compounds - EPA 8270C	2,4-Dichlorophenol	ppb	<1.16
Semivolatile Compounds - EPA 8270C	1,2,4-Trichlorobenzene	ppb	<1.38
Semivolatile Compounds - EPA 8270C	Naphthalene	ppb	0.72
Semivolatile Compounds - EPA 8270C	4-Chloroaniline	ppb	<1.26
Semivolatile Compounds - EPA 8270C	Hexachlorobutadiene	ppb	<1.32
Semivolatile Compounds - EPA 8270C	4-Chloro-3-methylphenol	ppb	<0.88
Semivolatile Compounds - EPA 8270C	2-Methylnaphthalene	ppb	<1.18
Semivolatile Compounds - EPA 8270C	Hexachlorocyclopentadiene	ppb	<5.32
Semivolatile Compounds - EPA 8270C	2,4,6-Trichlorophenol	ppb	<1.28
Semivolatile Compounds - EPA 8270C	2,4,5-Trichlorophenol	ppb	<1.10
Semivolatile Compounds - EPA 8270C	2-Chloronaphthalene	ppb	<0.84
Semivolatile Compounds - EPA 8270C	2-Nitroaniline	ppb	<1.40
Semivolatile Compounds - EPA 8270C	Dimethyl phthalate	ppb	<1.08
Semivolatile Compounds - EPA 8270C	Acenaphthylene	ppb	<0.86
Semivolatile Compounds - EPA 8270C	2,6-Dinitrotoluene	ppb	<0.62
Semivolatile Compounds - EPA 8270C	3-Nitroaniline	ppb	<0.78
Semivolatile Compounds - EPA 8270C	Acenaphthene	ppb	0.90
Semivolatile Compounds - EPA 8270C	2,4-Dinitrophenol	ppb	<2.64
Semivolatile Compounds - EPA 8270C	4-Nitrophenol	ppb	2.80
Semivolatile Compounds - EPA 8270C	Dibenzofuran	ppb	0.40
Semivolatile Compounds - EPA 8270C	2,4-Dinitrotoluene	ppb	<1.02
Semivolatile Compounds - EPA 8270C	Diethylphthalate	ppb	5.50
Semivolatile Compounds - EPA 8270C	4-Chlorophenyl-phenyl ether	ppb	<1.56
Semivolatile Compounds - EPA 8270C	Fluorene	ppb	0.90

**Environmental Testing Laboratories, Inc.**

**208 Route 109, Farmingdale, New York 11735**

**Phone - 631-249-1456 Fax - 631-249-8344**

Semivolatile Compounds - EPA 8270C	4-Nitroaniline	ppb	<1.46
Semivolatile Compounds - EPA 8270C	4,6-Dinitro-2-methylphenol	ppb	<0.96
Semivolatile Compounds - EPA 8270C	N-nitrosodiphenylamine	ppb	<1.56
Semivolatile Compounds - EPA 8270C	4-Bromophenyl-phenylether	ppb	<0.90
Semivolatile Compounds - EPA 8270C	Hexachlorobenzene	ppb	<1.44
Semivolatile Compounds - EPA 8270C	Pentachlorophenol	ppb	<3.02
Semivolatile Compounds - EPA 8270C	Phenanthrene	ppb	9.50
Semivolatile Compounds - EPA 8270C	Anthracene	ppb	1.40
Semivolatile Compounds - EPA 8270C	Di-n-butylphthalate	ppb	0.60
Semivolatile Compounds - EPA 8270C	Fluoranthene	ppb	12.8
Semivolatile Compounds - EPA 8270C	Pyrene	ppb	11.0
Semivolatile Compounds - EPA 8270C	Butylbenzylphthalate	ppb	<1.62
Semivolatile Compounds - EPA 8270C	3,3'-Dichlorobenzidine	ppb	<1.50
Semivolatile Compounds - EPA 8270C	Benzo(a)anthracene	ppb	4.80
Semivolatile Compounds - EPA 8270C	Chrysene	ppb	6.80
Semivolatile Compounds - EPA 8270C	bis(2-Ethylhexyl)phthalate	ppb	18.0
Semivolatile Compounds - EPA 8270C	Di-n-octylphthalate	ppb	<1.56
Semivolatile Compounds - EPA 8270C	Benzo(b)fluoranthene	ppb	5.20
Semivolatile Compounds - EPA 8270C	Benzo(k)fluoranthene	ppb	4.50
Semivolatile Compounds - EPA 8270C	Benzo(a)pyrene	ppb	4.30
Semivolatile Compounds - EPA 8270C	Indeno(1,2,3-cd)pyrene	ppb	1.20
Semivolatile Compounds - EPA 8270C	Dibenzo(a,h)anthracene	ppb	<1.16
Semivolatile Compounds - EPA 8270C	Benzo(g,h,i)perylene	ppb	1.20
Volatiles - EPA 8260B	Dichlorodifluoromethane	ppb	<0.38
Volatiles - EPA 8260B	Chlorodifluoromethane	ppb	<0.25
Volatiles - EPA 8260B	Chloromethane	ppb	<0.32
Volatiles - EPA 8260B	Vinyl Chloride	ppb	<0.23
Volatiles - EPA 8260B	Bromomethane	ppb	<0.32
Volatiles - EPA 8260B	Chloroethane	ppb	<0.24
Volatiles - EPA 8260B	Trichlorofluoromethane	ppb	<0.27
Volatiles - EPA 8260B	1,1,2-Trichlorotrifluoroethane	ppb	<0.36
Volatiles - EPA 8260B	1,1-Dichloroethene	ppb	<0.27
Volatiles - EPA 8260B	Acetone	ppb	29.6
Volatiles - EPA 8260B	Carbon disulfide	ppb	<0.19
Volatiles - EPA 8260B	Methylene Chloride	ppb	<0.21
Volatiles - EPA 8260B	t-1,2-Dichloroethene	ppb	<0.31
Volatiles - EPA 8260B	Methyl t-butyl ether	ppb	1.30
Volatiles - EPA 8260B	1,1-Dichloroethane	ppb	<0.30
Volatiles - EPA 8260B	2,2-Dichloropropane	ppb	<0.27
Volatiles - EPA 8260B	c-1,2-Dichloroethene	ppb	<0.24
Volatiles - EPA 8260B	2-Butanone	ppb	1.00
Volatiles - EPA 8260B	Bromochloromethane	ppb	<0.25
Volatiles - EPA 8260B	Chloroform	ppb	<0.26
Volatiles - EPA 8260B	1,1,1-Trichloroethane	ppb	<0.26
Volatiles - EPA 8260B	Carbon Tetrachloride	ppb	<0.22
Volatiles - EPA 8260B	1,1-Dichloropropene	ppb	<0.39
Volatiles - EPA 8260B	Benzene	ppb	<0.21
Volatiles - EPA 8260B	1,2-Dichloroethane	ppb	<0.23
Volatiles - EPA 8260B	Trichloroethene	ppb	<0.36
Volatiles - EPA 8260B	1,2-Dichloropropane	ppb	<0.31
Volatiles - EPA 8260B	Dibromomethane	ppb	<0.24
Volatiles - EPA 8260B	Bromodichloromethane	ppb	<0.20
Volatiles - EPA 8260B	2-Chloroethylvinylether	ppb	<0.33
Volatiles - EPA 8260B	c-1,3-Dichloropropene	ppb	<0.16
Volatiles - EPA 8260B	4-Methyl-2-pentanone	ppb	<0.63
Volatiles - EPA 8260B	Toluene	ppb	<0.20
Volatiles - EPA 8260B	t-1,3-Dichloropropene	ppb	<0.16

**Environmental Testing Laboratories, Inc.**

208 Route 109, Farmingdale, New York 11735

Phone - 631-249-1456 Fax - 631-249-8344

Volatiles - EPA 8260B	1,1,2-Trichloroethane	ppb	<0.16
Volatiles - EPA 8260B	Tetrachloroethene	ppb	<0.11
Volatiles - EPA 8260B	1,3-Dichloropropane	ppb	<0.21
Volatiles - EPA 8260B	2-Hexanone	ppb	<0.94
Volatiles - EPA 8260B	Dibromochloromethane	ppb	<0.13
Volatiles - EPA 8260B	1,2-Dibromoethane	ppb	<0.17
Volatiles - EPA 8260B	Chlorobenzene	ppb	<0.15
Volatiles - EPA 8260B	1,1,1,2-Tetrachloroethane	ppb	<0.20
Volatiles - EPA 8260B	Ethylbenzene	ppb	<0.22
Volatiles - EPA 8260B	m,p-xylene	ppb	<0.34
Volatiles - EPA 8260B	o-xylene	ppb	<0.25
Volatiles - EPA 8260B	Styrene	ppb	<0.20
Volatiles - EPA 8260B	Bromoform	ppb	<0.21
Volatiles - EPA 8260B	Isopropylbenzene	ppb	<0.15
Volatiles - EPA 8260B	Bromobenzene	ppb	<0.20
Volatiles - EPA 8260B	1,1,2,2-Tetrachloroethane	ppb	<0.23
Volatiles - EPA 8260B	n-Propylbenzene	ppb	<0.16
Volatiles - EPA 8260B	1,2,3-Trichloropropane	ppb	<0.35
Volatiles - EPA 8260B	p-Ethyltoluene	ppb	<0.16
Volatiles - EPA 8260B	1,3,5-Trimethylbenzene	ppb	<0.20
Volatiles - EPA 8260B	2-Chlorotoluene	ppb	<0.25
Volatiles - EPA 8260B	4-Chlorotoluene	ppb	<0.22
Volatiles - EPA 8260B	tert-Butylbenzene	ppb	<0.19
Volatiles - EPA 8260B	1,2,4-Trimethylbenzene	ppb	<0.17
Volatiles - EPA 8260B	sec-Butylbenzene	ppb	<0.22
Volatiles - EPA 8260B	4-Isopropyltoluene	ppb	<0.17
Volatiles - EPA 8260B	1,3-Dichlorobenzene	ppb	<0.17
Volatiles - EPA 8260B	1,4-Dichlorobenzene	ppb	<0.10
Volatiles - EPA 8260B	1,2-Dichlorobenzene	ppb	<0.11
Volatiles - EPA 8260B	p-Diethylbenzene	ppb	<0.22
Volatiles - EPA 8260B	n-Butylbenzene	ppb	<0.17
Volatiles - EPA 8260B	1,2,4,5-Tetramethylbenzene	ppb	<0.50
Volatiles - EPA 8260B	1,2-Dibromo-3-chloropropane	ppb	<0.42
Volatiles - EPA 8260B	1,2,4-Trichlorobenzene	ppb	<0.13
Volatiles - EPA 8260B	Hexachlorobutadiene	ppb	<0.45
Volatiles - EPA 8260B	Naphthalene	ppb	2.20
Volatiles - EPA 8260B	1,2,3-Trichlorobenzene	ppb	<0.19
Mercury by Method 200.7 CLP-M	Mercury	ppm	0.0027
RCRA Metals by Method 200.7 CLP-M	Arsenic	ppm	0.011
RCRA Metals by Method 200.7 CLP-M	Barium	ppm	0.74
RCRA Metals by Method 200.7 CLP-M	Cadmium	ppm	0.16
RCRA Metals by Method 200.7 CLP-M	Chromium	ppm	0.077
RCRA Metals by Method 200.7 CLP-M	Lead	ppm	1.71
RCRA Metals by Method 200.7 CLP-M	Selenium	ppm	<0.014
RCRA Metals by Method 200.7 CLP-M	Silver	ppm	<0.0033

**APPENDIX C**

**Health and Safety Plan**

---

**HEALTH AND SAFETY PLAN**

Closure of the Less than 90-Day Container Storage Areas  
&  
Investigation of Solid Waste Management Units  
Bayer Corporation Hicksville Polymer Plant  
Hicksville, New York

Prepared by: Kathleen Harvey

Approved by: \_\_\_\_\_  
ENSR Project Manager

Date: \_\_\_\_\_

---

## Table of Contents

1. Introduction.....	1
1.1 HASP Applicability.....	1
1.2 Organization/Responsibilities .....	1
1.2.1 ENSR Project Manager .....	1
1.2.2 ENSR Regional Health and Safety Manager .....	2
1.2.3 ENSR Site Safety Officer .....	2
1.2.4 ENSR Field Personnel and Contractor Personnel .....	3
1.2.5 ENSR Contractors.....	4
1.3 Modification of the HASP .....	4
2. Site Description and History.....	5
2.1 Site Location/Site History .....	5
2.2 Previous Manufacturing Operations .....	6
2.2.1 Plant No. 1 .....	6
2.2.2 Plant No. 2 .....	6
2.2.3 Plant No. 3 .....	6
2.2.4 Pilot Plant.....	6
2.3 Less Than 90-Day Container Storage Area (CSA).....	7
2.3.1 CSA at Plant No. 3.....	7
2.3.2 CSA at Plant No. 1 .....	7
2.4 Solid Waste Management Units .....	7
3. Scope of Work .....	11
3.1 CSA Closure Activities .....	11
3.2 SWMU Investigations.....	11
3.2.1 Soil Sampling .....	11
4. Chemical Hazard Assessment and Controls.....	13
4.1 Chemical Hazards.....	13
4.1.1 Solvents in the Container Storage Areas.....	13
4.1.2 Other Constituents of Concern.....	14
4.1.3 Vinyl Chloride .....	15
4.1.4 Petroleum Hydrocarbons and Polychlorinated Biphenyls (PCBs) Associated with Heat Transfer Systems .....	16
4.1.5 Dimethylformamide .....	16

---

4.1.6 Exhaust Gases if Internal Combustion Engines are Used in Interior Locations of the Facility .....	17
4.2 Chemical Exposure and Control.....	17
4.2.1 Chemical Exposure Potential .....	17
4.2.2 Chemical Exposure Control.....	17
5. Physical Hazards and Controls.....	19
5.1 Working in Close Proximity to On-Going Facility Decommissioning Activities .....	19
5.2 Utility Hazards.....	19
5.2.1 Underground Utilities.....	19
5.2.2 Overhead Utilities.....	20
5.3 Traffic Hazards.....	20
5.4 Increased Eye Hazard when Drilling through Concrete or Asphalt .....	20
5.5 Geoprobe Hazards.....	20
5.6 Knife Safety.....	21
5.7 Noise.....	22
5.8 Back Safety.....	22
5.9 Electrical Hazards .....	23
5.10 Slips, Trips and Falls .....	24
5.11 Thermal Stress .....	24
5.11.1 Cold Stress .....	24
5.11.2 Heat Stress .....	26
6. Air Monitoring .....	28
6.1 Direct Reading Instruments.....	28
6.2 Personal Air Sampling.....	29
6.3 Calibration and Recordkeeping .....	30
6.4 Community Air Monitoring Plan.....	30
7. Personal Protective Equipment.....	30
7.1 Chemical Protective Clothing .....	30
7.2 Respiratory Protection.....	31
7.3 Other Protective Equipment .....	32
8. Site Control.....	33
8.1 Designation of Zones .....	33
8.1.1 Exclusion Zone.....	34
8.1.2 Contamination Reduction Zone.....	34

---



---

8.1.3 Support Zone .....	34
8.2 Safety Practices .....	34
9. Decontamination.....	36
9.1 Personal Decontamination .....	36
9.2 Sanitation .....	36
10. Medical Monitoring and Training Requirements .....	37
10.1 Medical Monitoring.....	37
10.2 Health and Safety Training .....	37
10.2.1 HAZWOPER .....	37
10.2.2 Pre-Entry Briefing.....	37
10.2.3 Bayer Facility Safety Orientation .....	37
10.2.4 Daily Safety Briefings .....	37
11. Emergency Response .....	38
11.1 Employee Training.....	38
11.2 Alarm Systems/Emergency Signals .....	38
11.3 Escape Routes and Procedures .....	39
11.4 Rescue and Medical Duty Assignments.....	39
11.5 Designation of Responsible Parties .....	39
11.6 Employee Accounting Method .....	40
11.7 Accident Reporting and Investigation.....	40

## 1. Introduction

### 1.1 HASP Applicability

This site-specific Health and Safety Plan (HASP) has been developed by ENSR Corporation (ENSR). It establishes the health and safety procedures to minimize any potential risk to ENSR personnel and contractors hired by ENSR involved with the closure of the less-than 90-day container storage areas (CSAs) and the investigation of the potential solid waste management units (SWMUs) at the Bayer Corporation (Bayer) Hicksville Polymers Plant located in Hicksville, New York.

This HASP has been written to comply with the requirements of the Occupational Safety and Health Administration (OSHA) Hazardous Waste Operations and Emergency Response Standard (29 CFR 1910.120). All activities covered by this HASP must be conducted in complete compliance with this HASP and with all applicable federal, state, and local health and safety regulations. Personnel covered by this HASP who cannot or will not comply will be excluded from site activities.

This plan will be distributed to each ENSR employee and contractors hired by ENSR who are involved with environmental activities covered by this plan. Each employee must sign a copy of the attached health and safety plan receipt and acceptance form (see Attachment A).

### 1.2 Organization/Responsibilities

The implementation of health and safety at this project location will be the shared responsibility of the ENSR Project Manager (PM), the ENSR Regional Health and Safety Manager (RHSM), the ENSR Project Site Safety Officer (SSO) and all other ENSR and ENSR-contracted personnel providing on-site services at the Hicksville facility.

#### 1.2.1 ENSR Project Manager

The ENSR PM (Frank Myerski) is the individual who has the primary responsibility for ensuring the overall health and safety of employees providing services during the proposed closure and investigative activities. As such, the PM is responsible for ensuring that the requirements of this HASP are implemented. Some of the PM's specific responsibilities include:

- Assuring that all personnel to whom this HASP applies have received a copy of it;

- Providing the RHSM with updated information regarding environmental conditions at the site and the scope of on-site services being conducted by ENSR and ENSR's contractors;
- Providing adequate authority and resources to the ENSR SSO to allow for the successful implementation of all necessary safety procedures;
- Supporting the decisions made by the SSO and RHSM;
- Maintaining regular communications with the SSO and, if necessary, the RHSM; and,
- Providing project scheduling and planning activities.

### **1.2.2 ENSR Regional Health and Safety Manager**

The ENSR RHSM (Kathleen Harvey) is the individual responsible for the preparation, interpretation and modification of this HASP. Modifications to this HASP which may result in less stringent precautions cannot be undertaken by the PM or the SSO without the approval of the RHSM. Specific duties of the RHSM include:

- Writing, approving and amending the HASP for this project;
- Advising the PM and SSO on matters relating to health and safety during the implementation of the proposed scope of work;
- Recommending appropriate personal protective equipment (PPE) and air monitoring instrumentation, if necessary, to protect personnel from potential site hazards;
- Conducting accident investigations when ENSR employees are involved; and,
- Maintaining regular contact with the PM and SSO to evaluate site conditions and new information which might require modifications to the HASP.

### **1.2.3 ENSR Site Safety Officer**

All ENSR field technicians who are implementing the closure and investigative activities at the facility are responsible for implementing the safety requirements specified in this HASP. However, one field technician will serve as the SSO. The SSO will be appointed by the PM. The SSO will be on-site during all activities covered by this HASP. The SSO is responsible for

enforcing the requirements of this HASP once work begins. Some of the SSO's specific responsibilities include:

- Assuring that all personnel to whom this HASP applies have submitted a completed copy of the HASP receipt and acceptance form;
- Maintaining a high level of health and safety consciousness among those employees who are covered by this HASP;
- Procuring and distributing the required PPE for ENSR employees working on-site;
- Procuring the air monitoring instrumentation required and performing air monitoring for ENSR activities, if necessary;
- Verifying that all PPE and health and safety equipment used by ENSR is in good working order;
- Monitoring and controlling the safety performance of all personnel covered by this HASP and working within the established restricted areas to ensure that required safety and health procedures are being followed;
- Conducting accident/incident investigations and preparing accident/incident investigation reports that involve ENSR employees; and
- Initiating emergency response procedures in accordance with Section 11.0 of this HASP.

#### **1.2.4 ENSR Field Personnel and Contractor Personnel**

All ENSR field personnel and contractor personnel covered by this HASP are responsible for following the health and safety procedures specified in this HASP and for performing their work in a safe and responsible manner. Some of the specific responsibilities of the field personnel are as follows:

- Reading the HASP in its entirety prior to the start of on-site work;
- Submitting a completed HASP Acceptance Form and documentation of medical surveillance and training to the ENSR PM prior to the start of work;

- 
- Bringing forth any questions or concerns regarding the content of the HASP to the PM or the SSO prior to the start of work;
  - Reporting all accidents, injuries and illnesses, regardless of their severity, to the ENSR SSO; and
  - Complying with the requirements of this HASP and the requests of the SSO.

### **1.2.5 ENSR Contractors**

Additionally, subcontractors are responsible for:

- Ensuring, via daily inspections, that their equipment is in good working order;
- Operating their equipment in a safe manner;
- Providing ENSR with copies of material safety data sheets (MSDS) for all hazardous materials brought on-site; and,
- Providing all the required PPE for their employees

### **1.3 Modification of the HASP**

The procedures in this HASP have been developed based on current knowledge regarding the specific chemical and physical hazards that are known or anticipated for the proposed scope of services. Every effort has been made to address the chemical hazards that may be encountered during the implementation of the work plan. Similarly, this document also discusses the physical hazards that ENSR employees may encounter during the implementation of the proposed scope of work. However, unanticipated site-specific conditions or situations may occur during the implementation of this project that are not addressed in this document. As such, this HASP must be considered a *working document* that is subject to change to meet the needs of this dynamic project.

## 2. Site Description and History

### 2.1 Site Location/Site History

The Bayer Corporation Hicksville Polymer Plant is located at 125 New South Road in Hicksville, New York. The manufacturing facility is located on a 14-acre tract of land within an industrial park. The manufacturing facilities were composed of Plant No. 1, Plant No. 2, Plant No. 3, the Pilot Plant and associated buildings and sheds throughout the property. The facility is bordered by the Long Island Railroad to the south and west, the Grumman Aerospace Corporation facilities to the east, and various commercial and industrial facilities to the north.

The chemical manufacturing plant located at 125 New South Road was first constructed in 1945. Additional construction occurred over a 20-year period. In the early 1950's, the facility produced rubber latex and polyvinyl chloride (PVC) compounds, PVC film and sheet, plasticizers and polyesters. Around 1954, PVC resin manufacturing began. From 1966 through February 26, 1982, the land, buildings, machinery and equipment comprising this facility were owned and operated by Hooker Chemical and Plastic Corporation/Occidental Chemical Company (HCPC/OCC). In the early 1980s as a result of past practices, the HCPC/OCC Hicksville facility was declared a Superfund site and placed in the National Priorities List by both the United States Environmental Protection Agency (US EPA) and the New York State Department of Environmental Conservation (NYSDEC). Under EPA's supervision, HCPC/OCC is carrying out the remedial actions addressing both soils and groundwater.

On February 26, 1982, RUCO Polymer Corporation (RUCO), a newly formed company, purchased the facility from HCPC/OCC. As part of the purchase agreement, HCPC/OCC agreed to indemnify RUCO for liabilities associated with any environmental issues arising out of the facility's operations conducted prior to February 26, 1982. Sybron Chemical Corporation subsequently purchased RUCO in 1998. Bayer became the owner of the RUCO Polymers facility in October 2000 as part of Bayer's acquisition of Sybron Chemicals Corporation. Bayer received the HCPC/OCC indemnification for liabilities associated with any environmental issues arising out of the facility's past operations as the successor to RUCO Polymer Corporation.

The facility has terminated all production operations at the site and is currently undergoing decommissioning and demolition activities. Bayer's objectives are to fulfill its RCRA facility closure responsibilities and divest the site so that it can be returned to beneficial use.

---

## **2.2 Previous Manufacturing Operations**

Production at the facility consisted of two manufacturing processes, which produced polyurethane and polyester.

### **2.2.1 Plant No. 1**

Plant No. 1 historically produced ester oils and polyesters. The process was a direct esterification of glycols, polyols, dibasic acids and polycarboxylic acids. Plant No. 2 also manufactured polyesters in processes paralleling those of Plant No. 1. Polyurethanes were also manufactured in Plant No. 2. The polyurethane manufacturing process was further broken into three subcategories, which produces three separate products; polyurethane in solvent, polyurethane in water, and solid polyurethane.

### **2.2.2 Plant No. 2**

Plant No. 2 was used for the manufacture of polyvinyl resins (PVC) for a period of 20 years ending in the mid-1970s. The PVC resin process was a suspension polymerization in which an aqueous solution of vinyl chloride was agitated while polymerization occurred. A wastewater stream was discharged to the ground in connection with this process. This wastewater may have contained traces of gaseous vinyl chloride. Also in Plant No.2, a styrene butadiene latex process operated during the same time period. This process produced small amounts of wastewater, which possibly contained styrene butadiene rubber process monomers.

### **2.2.3 Plant No. 3**

Plant No. 3 was used as a warehouse and contained drums and bags of materials and end products relating to the various manufacturing processes of Plants 1 and 2. Previous owners of the plant used the building to manufacture plastic molding compounds. These were formulated non-hazardous PVC pellets and powders that were marketed for the molding of phonograph records and bottles. The manufacturing process consisted of blending powders and extruding pellets.

### **2.2.4 Pilot Plant**

Historically, the Pilot Plant was used for small-scale batches of experimental product or developing techniques to improve the larger scale manufacturing process. Waste minimization techniques were developed in the Pilot Plant as well as methods to use less toxic solvents in the manufacturing process.

## **2.3 Less Than 90-Day Container Storage Area (CSA)**

Wastes generated during the urethanes manufacturing process included spent solvents that may have included toluene, N-methyl pyrrolidone, isopropyl alcohol, isophthalic acid, methyl ethyl ketone, and methyl isobutyl ketone. Sealed hazardous waste solvent drums containing one or more of these wastes were held for less than 90 days in the CSAs in Plants No. 1 and 3 before being shipped to licensed waste disposal facilities. Small amounts of solid hazardous wastes were also produced as a result of laboratory testing of ester products and stored in the CSAs until final disposition.

### **2.3.1 CSA at Plant No. 3**

The CSA at Plant No. 3 is an approximately 550-square foot area in the southeastern portion of the building. Drums of hazardous waste generated at the facility were stored in this area and placed on spill pallets. The walls of the storage areas are made of cinder block, with primary access to the storage area being through two internal garage doors located along the south wall. The drum pallets were stored on a concrete floor that has very few observable cracks. The CSA at Plant No. 3 could contain a maximum of thirty-six, 55-gallon drums equal to 1,980 gallons of hazardous waste.

### **2.3.2 CSA at Plant No. 1**

The CSA at Plant No. 1 is an approximately 490-square foot area in the western portion of the plant. The area has a concrete floor that has very few observable cracks. During routine operations, the CSA in Plant No. 1 contained little, if any, hazardous waste (one or two 55-gallon drums maximum, and usually none). The majority of the wastes stored in Plant No. 1 were non-hazardous. The drums were moved via the walkway connecting Plant No. 1 and the warehouse located south of Plant No. 1 to the loading area for shipment offsite.

## **2.4 Solid Waste Management Units**

Since August 2002, ENSR and Bayer have been reviewing historical reports and drawings and have interviewed plant personnel to determine where any site contamination may have occurred. Additionally, field observations for stained soils or stressed vegetation were made to identify potential areas for further investigation prior to site closure. Fifty-one (51) potential solid waste management units (SWMUs) have been identified within the four main areas that the site was divided into. These four main areas include:

- Plant No. 1 - (includes the warehouse attached via a walkway to southwest of the Plant)



- 
- Plant No. 2 - (includes the waste accumulation and compaction area southeast of plant as well as tanks located outside of the northeast wall of Plant No 2)
  - Plant No. 3 - (includes the waste accumulation area in the plant as well as the tanks located outside of the northeast wall of Plant No. 3)
  - Miscellaneous Areas
    - Tank Farm
    - Former Stockpiled Soil Area
    - Historical Spills
    - Storage Areas
    - Recharge Basins
    - Heating System
    - Cess Pools and French Drains
    - Electrical Power Transformers
    - Buildings and Structures

Table 1 summarizes the 51 potential SWMUs and their locations at the facility.

**TABLE 1**

**Solid Waste Management Units**

<b>SWMU</b>	<b>Location</b>	<b>Description</b>
1	Plant 1	Plant 1 <90day storage unit
2	Plant 1	Lab satellite accumulation area
3	Plant 1	Waste water tanks 1, 11A, 11B
4	Plant 1	Former liquids incinerator area
5	Plant 1	Transfer Station, Plant 1
6	Plant 1	Transfer station, glycol tanks
7	Plant 1	Transfer station, adipic acid silos and wastewater
8	Plant 1	UST, closed in place
9	Plant 1	UST, removed
10	Plant 1	UST, removed
11	Plant 1	Boiler condensate run-off
12	Plant 2	Waste accumulation area
13	Plant 2	Former RCRA >90day storage unit
14	Plant 2	Waste Compactor and Scrap Metal Area
15	Plant 2	Distillate wastewater Tank 2
16	Plant 2	Reactor 4 knockout tank
17	Plant 2	DMF Pump Overflow
18	Plant 2	Transfer Station, Plant 2 Diol Tank
19	Plant 2	Fume Incinerator
20	Plant 3	RCRA < 90day storage unit
21a & 21b	Plant 3	Transfer Station, adipic acid silos
22	Plant 3	Tote storage area
23	Plant 3	Non-hazardous waste accumulation
24	Tank Farm	Transfer station, tank farm, dispensing station and sump
25	Pilot Plant	Soil pile accumulation from removal of SWMU 24
26	East of Plant 1 and adjacent to pilot plant	Historical Spills
27a	West of Plant 3	Non-hazardous, off-spec, damaged product and raw material locations
27 b	West of warehouse and SW of Plant 1	Non-hazardous, off-spec, damaged product and raw material locations
27 c	West of Plant 1	Non-hazardous, off-spec, damaged product and raw material locations
27 d	Outside of western lab wall	Non-hazardous, off-spec, damaged

		product and raw material locations
27 e	SE of Plant 2	Non-hazardous, off-spec, damaged product and raw material locations
27 f	Outside Plant 2 along eastern wall	Non-hazardous, off-spec, damaged product and raw material locations
27 g	East of Plant 2	Non-hazardous, off-spec, damaged product and raw material locations
27 h	NE of Plant 2 and SW of shed	Non-hazardous, off-spec, damaged product and raw material locations
27 i	Rail spur along the outside wall of Plant 2 along the western side	Non-hazardous, off-spec, damaged product and raw material locations
27 j	SW of Plant 2	Non-hazardous, off-spec, damaged product and raw material locations
28	Between Plant No.1 and Sump No 2	Recharge Basin/Sump 1
29	Far SE corner of property	Recharge Basin/Sump 2
30	Along the eastern property line due east of Plant 1	Recharge Basin/Sump 3, Stormwater
31	Along the eastern property line due east of Plant 2	Recharge Basin/Sump 4, SPDES Discharge
32	East of Plant 2 and just NE of 27 g	Recharge Basin Extension/Sump 5
33	East of Plant 2 and just NW of 27 g	Recharge Basin/Sump 6
34	E edge of property line near Plant 2	Cooling Tower Area
35 a	East of Admin Bldg	Septic Tanks/French Drains
35 b	NW of Plant 1	Septic Tanks/French Drains
35 c	W of Plant 1	Septic Tanks/French Drains
35 d	SW of Plant 1	Septic Tanks/French Drains
35 e	SW of Plant 2	Septic Tanks/French Drains
35 f	NW of Pilot Plant	Septic Tanks/French Drains
35 g	South of Admin Bldg	Septic Tanks/French Drains
36	Immediately south of Admin Bldg	Admin Bldg Closed Lab Storage Area

### 3. Scope of Work

The activities addressed by this HASP include the closure of the CSAs and the investigation of the potential SWMUs.

#### 3.1 CSA Closure Activities

The closure of the CSAs will be accomplished by removing all hazardous waste and hazardous waste residues from the areas and successfully decontaminating associated equipment and the CSAs' surfaces.

Once the hazardous (and non-hazardous) waste inventory is removed from the CSAs and transported off-site for treatment and disposal by a private contractor, the floor and walls of the each CSA will be visually inspected for any evidence of past leakage and contamination. Any residues will be manually removed from the flooring and drummed for off-site disposal. The floor and walls will then be steam-cleaned to visually remove any remaining contaminants. The rinseate will be collected by vacuuming the liquid into a tank truck (or drums) for off-site transport. Prior to transport, a sample of the rinseate water collected in the tank truck will be collected for characterization and profiling.

Following the final steam cleaning, rinseate will be sampled and the results compared to the background sample results to determine whether the CSA has been adequately cleaned. Background samples of rinseate will be collected from sections of the facility that have never contained or stored hazardous wastes or hazardous materials.

#### 3.2 SWMU Investigations

##### 3.2.1 Soil Sampling

To determine the extent of soil contamination at the site, soil samples will be collected from each SWMU using direct-push technology. In most cases, the soil borings will be advanced to a depth of six feet below ground surface (bgs). Soil borings in the vicinity of recharge basins or underground storage tanks (USTs) will be advanced to six feet below the bottom of the basin or the tank. Soil samples will be collected from the exterior of the tank containment dikes using a hand-auger.

---

Soil samples that are collected beneath concrete slabs or asphalt pavement will have an approximately 2-inch diameter hole penetrated through the concrete with an air-hammer rock drill prior to sampling. Similarly, a jackhammer or air hammer will be used to break through the containment structure to access the underlying soil around the sumps located within the tank containment structure.

Soil samples will be field screened using a photoionization detector (PID) and/or a flameionization detector (FID) and then sent off-site for laboratory analyses.

## 4. Chemical Hazard Assessment and Controls

### 4.1 Chemical Hazards

#### 4.1.1 Solvents in the Container Storage Areas

Toluene, isopropyl alcohol, isophthalic acid, N-methyl pyrrolidone, methyl ethyl ketone (MEK) and methyl isobutyl ketone (MIBK) were the typical solvents used in polyurethane manufacturing and are the wastes that were most likely stored in the CSAs, especially the CSA located in Plant No. 3.

##### 4.1.1.1 Toluene

Exposure to the vapors of toluene above the OSHA permissible exposure limit (PEL) may produce irritation of the mucous membranes of the upper respiratory tract, nose and mouth. Overexposure may also result in the depression of the central nervous system. Symptoms of such exposure include drowsiness, headache, fatigue and drunken-like behaviors. The OSHA PEL for toluene is 200 ppm, as an 8-hour, time-weighted average (TWA). The American Conference of Governmental Industrial Hygienists (ACGIH) recommends a threshold limit value (TLV) of 50 ppm, as an 8-hr TWA.

##### 4.1.1.2 Isopropyl Alcohol

Although the typical route of exposure is ingestion, symptoms of alcohol poisoning can occur from the inhalation of alcohol vapors. The vapors of isopropanol are irritating to the eyes and mucous membranes. Inhalation of isopropanol vapors above the established OSHA PEL of 400 ppm may depress the central nervous system. Symptoms include headache, giddiness and drunken-like behavior.

##### 4.1.1.3 Isophthalic Acid

Isophthalic acid is a colorless solid in the form of needles or a crystalline powder. It has a slight, unpleasant odor. Exposure to isophthalic acid can be irritating to the eyes, skin and respiratory tract. Chronic effects include damage to the kidney. No OSHA PEL has been established and the ACGIH has not recommended a TLV for isophthalic acid.

##### 4.1.1.4 N-Methyl Pyrrolidone

*N-methyl pyrrolidone is a colorless liquid with a mild amine odor. It is used as a solvent for resins and as a spinning agent for PVC. It is irritating to the eyes and mildly irritating to the skin*

and respiratory tract. Exposure can also cause corneal clouding. Chronic effects of overexposure include elevated liver enzymes levels (based on animal studies). No OSHA PEL has been established and the ACGIH has not recommended a TLV for N-methyl pyrrolidone.

#### 4.1.1.5 MEK

MEK is a colorless liquid with an acetone-like odor. Systemic effects associated with overexposure to the vapors of MEK include eye, nose and respiratory tract irritation. Excessive overexposure results in narcosis with symptoms that include nausea, light-headedness, dizziness, incoordination and drunken-like behaviors. The OSHA PEL for MEK is 200 ppm, as an 8-hr TWA. The ACGIH recommends a TLV of 200 ppm as well.

#### 4.1.1.6 MIBK

MIBK is a flammable, colorless liquid with a characteristic camphor-like odor at about 100 ppm and objectionable at 200 ppm. Short-term overexposure to the vapors of MIBK may result in nausea, light-headedness, dizziness, incoordination and drunken-like behaviors as well as eye, nose and respiratory tract irritation.. The OSHA PEL for MIBK is 100 ppm, but the ACGIH recommends a TLV of 50 ppm, as an 8-hr TWA.

### 4.1.2 Other Constituents of Concern

The following general categories of chemicals have been prepared based on the manufacturing processes performed at the facility. These chemicals, as well as the above-mentioned solvents, may be encountered during the investigation of the potential SWMUs at the Bayer facility.

- Glycols
- Polyhydric alcohols
- Adipic acid, terephthalic acids and other organic acids
- Vinyl chloride

Material safety data sheets for all of the materials used at the Bayer Hicksville Plant are available to ENSR employees for review if necessary and upon request. Below is a summary of the pertinent health and safety concerns associated with these general categories of chemicals.

#### 4.1.2.1 Glycols

When heated or misted, diethylene and ethylene glycols can cause throat irritation, headache, and eye irritation. Inhalation of the vapor/mist may cause central nervous system effects and kidney and liver damage. OSHA has not established PELs for either glycol. The ACGIH has established a ceiling value of 100 mg/m<sup>3</sup> for ethylene glycol.

#### 4.1.2.2 Polyhydric Alcohols

*This group of chemicals is relatively non-toxic with only some of the polyols causing skin and eye irritation.*

#### 4.1.2.3 Adipic Acid

Adipic acid is an odorless solid that is shaped in white crystals or needles. The material is irritating to the eyes and skin specifically around the wrists, ankles and neck. No OSHA PEL has been established for adipic acid but the ACGIH recommends a TLV of 5 mg/m<sup>3</sup>, as an 8-hr TWA.

### 4.1.3 Vinyl Chloride

Due to historical manufacturing activities, vinyl chloride was a constituent of concern during remedial actions at the site. Due to the remedial actions that have taken place at the site, it is unlikely that ENSR will encounter this contaminant during the proposed SWMU investigations. However, as a precautionary measure, ENSR will screen for the presence of vinyl chloride during the proposed SWMU investigation.

The OSHA PEL for vinyl chloride is 1 ppm, as an 8-hour TWA and a 5 ppm ceiling value. Acute toxic effects due to overexposure to the vapors of vinyl chloride include lightheadedness, dulling of the senses and other symptoms resembling mild alcohol intoxication due to the depression of the central nervous system. Chronic overexposures to vinyl chloride result in liver damage, kidney dysfunction. Vinyl chloride is a known human carcinogen causing angiosarcoma of the liver. Excess cancers of the lung and lymphatic and nervous systems have also been reported in humans. Nonmalignant alterations such as fibrosis and connective tissue deterioration are also associated with chronic exposure to vinyl chloride.



---

#### **4.1.4 Petroleum Hydrocarbons and Polychlorinated Biphenyls (PCBs) Associated with Heat Transfer Systems**

##### **4.1.4.1 Petroleum Hydrocarbons**

Tank 34 is a 300-gallon tank containing diesel fuel. It is surrounded by an earthen containment dike and has been empty for many years. Tank 35 is a 14,500-gallon tank containing fuel oil # 2. Diesel fuel and fuel oils are generally considered to be of moderate to low toxicity. Federal or recommended airborne exposure limits have not been established for the vapors of diesel fuel or fuel oils. Inhalation of the vapor or mist may cause headache, dizziness, nausea, vomiting and a loss of coordination. Inhalation of high concentrations of the vapors may cause extensive pulmonary edema. Chronic direct skin contact with the liquids may produce skin irritation as a result of defatting. Repeated skin contact may also cause irritation of the hair follicles and block the sebaceous glands. This produces a rash of acne pimples and spots, usually on the arms and legs.

##### **4.1.4.2 Polychlorinated Biphenyls**

The process heating system may have PCB-containing heat transfer fluid makeup and/or content in Plant No.1 and the Pilot Plant. PCBs are a series of technical mixtures consisting of many isomers and compounds that vary from mobile oily liquids to white crystalline solids to hard noncrystalline resins. PCB oils are typically used in heat transfer applications, hydraulic fluids and lubricants. Technical products vary in composition and in the degree of chlorination. The higher the degree of chlorination, the greater the toxicity. Dermal contact with liquid PCBs may produce skin irritation or a rash. Prolonged or repeated skin contact may cause dermatitis or "chloracne." Studies suggest that chronic exposure to PCBs may be toxic to the liver.

##### **4.1.5 Dimethylformamide**

SWMU # 17, located in Plant 2, is described as DMF pump overflow. Dimethylformamide (DMF) is a colorless, slightly yellow liquid with a faint amine odor. It is used as a polymer solvent and a spinning solvent for acrylic fibers. The OSHA PEL for DMF is 10 ppm, as an 8-hr TWA. Exposure to DMF is irritating to the eyes, skin and respiratory tract. Exposure may also cause dizziness, sleep disorders, abdominal pain, vomiting and kidney, heart and liver damage. DMF may also be directly absorbed through the skin to cause systemic effects. DMF is considered to be a possible human carcinogen.

#### **4.1.6 Exhaust Gases if Internal Combustion Engines are Used in Interior Locations of the Facility**

If work is being conducted within one of the facility buildings and a traditional combustion engine machine is used, the build up of exhaust gases is a concern. Carbon monoxide is the most toxic of the exhaust gases. Carbon monoxide is an asphyxiant in that it prevents hemoglobin from binding with oxygen. Symptoms of acute carbon monoxide poisoning include intense headache, dizziness, nausea, and collapse. Initially the victim is pale; later the skin and mucous membranes may turn cherry-red in color. The OSHA PEL for carbon monoxide is 35 ppm, as an 8-hour TWA with a ceiling value of 200 ppm. The ACGIH recommends a TLV of 25 ppm, as an 8-hr TWA.

### **4.2 Chemical Exposure and Control**

#### **4.2.1 Chemical Exposure Potential**

The potential routes of chemical exposure to the field teams during the implementation of the proposed scopes of work include:

- Direct dermal contact with residues during manual removal from CSA surfaces
- Inhalation of solvent vapors during steam cleaning due to increased temperatures (that may increase volatility) and the closed nature of the CSAs
- Direct dermal/splash hazard during steam-cleaning of CSA surfaces
- Inhalation of solvent vapors or dusts during soil sampling although the use of direct-push technology and/or hand augering will greatly minimize this potential route of exposure

#### **4.2.2 Chemical Exposure Control**

ENSR will use several methods to control potential exposures that may occur during the implementation of the proposed CSA closures and investigation of the potential SWMUs:

- ENSR will be conducting air monitoring to determine the presence of petroleum and volatile organic vapors (VOCs) during the proposed activities. If exposures exceed the action levels as defined in Section 6.1, respiratory protection as discussed in Section 7.2, will be donned.
- A carbon monoxide meter will be used during indoor activities to ensure that exhaust gas from the drill rigs and other equipment is being adequately controlled. Even if the building is well-ventilated and the exhaust gas is ducted to the outside, a CO meter is still required.

- 
- To avoid direct dermal contact with contaminated media, protective clothing, as described in Section 7.1, will be required.
  - Although highly unlikely, exposure to all of the contaminants of concern may occur via ingestion (hand-to-mouth transfer). The decontamination procedures described in Section 9.0 address personal hygiene issues that will limit the potential for contaminant ingestion.

## 5. Physical Hazards and Controls

### 5.1 Working in Close Proximity to On-Going Facility Decommissioning Activities

Most of the decommissioning activities should be completed prior to the commencement of the proposed CSA Closure and SWMU investigations. However, in the event that such activities are not completed and ENSR and their subcontractors are working in close proximity to other contractors, the ENSR SSO will meet with all contractors to determine who is working where and what special hazards are associated with their work. If special hazards are identified, the contractors will work together to ensure the safety of all crews that may be working in the same area of the facility.

### 5.2 Utility Hazards

#### 5.2.1 Underground Utilities

New York law requires that, at least 48 hours prior to initiation of any subsurface work, a utility clearance be performed at the site. ENSR or the drilling contractor will contact New York City-Long Island One Call Center (1-800-272-4480) to request a mark-out of underground utilities in the proposed drilling locations. Work will not begin until the required utility clearances have been performed. Public utility clearance organizations typically do not mark-out underground utility lines that are located on private property. As such, ENSR or the drilling contractor must exercise due diligence and try to identify the location of any private utilities on the properties being investigated. ENSR or the drilling contractor can fulfill this requirement in several ways, including:

- *obtaining as-built drawings for the areas being investigated from the property owner;*
- *visually reviewing each proposed drilling location with the property owner or knowledgeable site representative;*
- *performing a geophysical survey to locate utilities or hiring a private line locating firm to determine the location of utility lines that are present at the property;*
- *identifying a no-drill zone; or*

- hand digging in the proposed drilling locations if insufficient data is available to accurately determine the location of the utility lines

### **5.2.2 Overhead Utilities**

Field personnel will be particularly aware of overhead lines in the work area. All equipment capable of having parts of its structure elevated near energized overhead lines shall be operated so that a minimum clearance of 20 feet {29 CFR 1910.133 (c) (3) (iii)} is maintained. Operating or erecting any machinery within 20 feet of high-voltage lines is a prohibited activity as defined in 12 NYCRR Part 57 (high voltage proximity).

### **5.3 Traffic Hazards**

While the plant is not operational from a manufacturing standpoint, there still may be considerable vehicular and truck traffic at the site due to the decommissioning of the facility. If work is being performed in a high traffic area (i.e. parking lot, shipping/receiving area, loading dock), the following precautions should be followed. All are designed to draw attention to you and to warn other people of your presence:

- Notify the property owner of your work location, dates of work and the anticipated work times. Suggest the possibility of a detour around the work area.
- Wear an orange safety vest. If work is being performed at dawn or dusk, the vests must have reflective tape.
- Set up traffic cones 50 feet in front of the work area. "Men at Work" signs should also be placed in a conspicuous area to warn others of your presence.

### **5.4 Increased Eye Hazard when Drilling through Concrete or Asphalt**

An increased eye hazard exists when coring through concrete or asphalt to access underlying soils. Employees must wear safety glasses with attached sideshields to protect them from flying debris. Employees may also choose to wear a faceshield over their glasses if impact from the debris is excessive.

### **5.5 Geoprobe Hazards**

Use of the Geoprobe System to collect soil samples will require all personnel in the vicinity of the operating unit to wear steel-toed boots, hardhats, hearing protection and safety eyewear. Personnel shall not remain in the vicinity of operating equipment unless it is required for their work responsibilities. Additionally, the following safety requirements must be adhered to:

- A remote vehicle ignition is located on the control panel of the Geoprobe unit. This allows the operator to start and stop the vehicle engine from the rear. This device must be tested prior to job initiation and periodically thereafter. All employees should be aware of how to access and operate the rear ignition.
- The driller must never leave the controls while the probe is being driven.
- Drillers, helpers and geologists must secure all loose clothing when in the vicinity of drilling operations.
- The Geoprobe vehicle shall not be moved any distance with the probe in the extended position. Check for clearance at roof or the vehicle before folding the Geoprobe out of the carrier vehicle.
- Be sure the parking brake is set before probing.
- Never allow the derrick foot to be lifted more than 6" off of the ground surface.
- Deactivate hydraulics when adding or removing probe rods, anvils or any tool in the hammer.
- Verify that all threaded parts are completely threaded together before probing.

### **5.6 Knife Safety**

Employees are at an increased risk of cutting themselves with the knives used to open the acetate soil sample liners used in the Geoprobe sampling technique. When using knives or blades, follow the safety precautions listed below:

- Keep your free hand out of the way
- Secure your work if cutting through thick material
- Use only sharp blades; dull blades require more force that results in less knife control
- Pull the knife toward you; pulling motions are easier to manage
- Don't put your knife in your pocket

- Use a self-retracting blade
- Wear leather or Kevlar™ gloves when using knives or blades.

### **5.7 Noise**

Use of drilling equipment and concrete coring equipment may expose ENSR employees to noise levels that exceed the OSHA PEL of 90 dB for an 8-hour day. Exposure to noise can result in the following:

- Temporary hearing losses where normal hearing returns after a rest period;
- Interference with speech communication and the perception of auditory signals;
- Interference with the performance of complicated tasks; and,
- Permanent hearing loss due to repeated exposure resulting in nerve destruction in the hearing organ.

Since personal noise monitoring will not be conducted during the proposed activities, employees must follow this general rule of thumb: If the noise levels are such that you must shout at someone 5 feet away from you, you need to be wearing hearing protection. Employees can wear either disposable earplugs or earmuffs but all hearing protection must have a minimum noise reduction rating (NRR) of 27 dB.

### **5.8 Back Safety**

Using the proper techniques to lift and move heavy pieces of equipment is important to reduce the potential for back injury. The following precautions should be implemented when lifting or moving heavy objects:

- Use mechanical devices to move objects that are too heavy to be moved manually. As an example, a drum dolly or fork-lift with a drum grapple should be used to move drums that are used to contain removed residues from the CSAs
- If mechanical devices are not available, ask another person to assist you.

- Bend at the knees, not the waist. Let your legs do the lifting.
- Do not twist while lifting
- Bring the load as close to you as possible before lifting
- Be sure the path you are taking while carrying a heavy object is free of obstructions and slip, trip and fall hazards

## 5.9 Electrical Hazards

If using portable tools that are electrically powered, follow the safety precautions listed below:

- Check to see that electrical outlets used to supply power during field operations is of the three wire grounding type.
- Extension cords used for field operations should be of the three wire grounding type and designed for hard or extra-hard usage. This type of cord uses insulated wires within an inner insulated sleeve and will be marked S, ST, STO, SJ, SJO or SJTO.
- NEVER remove the ground plug blade to accommodate ungrounded outlets.
- Do not use extension cords as a substitute for fixed or permanent wiring. Do not run extension cords through openings in walls, ceilings or floors.
- Protect the cord from becoming damaged if the cord is run through doorways, windows or across pinch points.
- Examine extension and equipment cords and plugs prior to each use. Damaged cords with frayed insulation or exposed wiring and damaged plugs with missing ground blades **MUST BE REMOVED** from service immediately.
- All portable or temporary wiring which is used outdoors or in other potentially wet or damp locations must be connected to a circuit that is protected by a ground fault circuit interrupter (GFCI). GFCI's are available as permanently installed outlets, as plug-in adapters and as extension cord outlet boxes. **DO NOT CONTINUE TO USE A PIECE OF EQUIPMENT OR EXTENSION CORD THAT CAUSES A GFCI TO TRIP.**



- When working in flammable atmospheres, be sure that the electrical equipment being used is approved for use in Class I, Division I atmospheres.
- Do not touch a victim who is still in contact with current. Separate the victim from the source using a dry, nonmetallic item such as a broomstick or cardboard box. Be sure your hands are dry and you are standing on a dry surface. Turn off the main electrical power switch and then begin rescue efforts.

## **5.10 Slips, Trips and Falls**

To facilitate closure, the surfaces of the CSAs are being steam-cleaned. Water that accumulates on the floor during the cleaning process presents a significant slip, trip and fall hazard to the work crew. Pools of water and rinseate will be removed from the work area as soon as possible, using a vacuum truck, to minimize this potential hazard.

## **5.11 Thermal Stress**

### **5.11.1 Cold Stress**

#### Types of Cold Stress

Cold injury is classified as either localized, as in frostbite, frostnip or chilblain; or generalized, as in hypothermia. The main factors contributing to cold injury are exposure to humidity and high winds, contact with wetness and inadequate clothing.

The likelihood of developing frostbite occurs when the face or extremities are exposed to a cold wind in addition to cold temperatures. The freezing point of the skin is about 30° F. The fluids around the cells of the body tissue freeze, causing the skin to turn white. This freezing is due to exposure to extremely low temperatures. As wind velocity increases, heat loss is greater and frostbite will occur more rapidly.

#### Symptoms of Cold Stress

The first symptom of frostbite is usually an uncomfortable sensation of coldness, followed by numbness. There may be a tingling, stinging or aching feeling in the effected area. The most vulnerable parts of the body are the nose, cheeks, ears, fingers and toes.

Symptoms of hypothermia, a condition of abnormally low body temperature, include uncontrollable shivering and sensations of cold. The heartbeat slows and may become irregular, the pulse weakens and the blood pressure changes. Pain in the extremities and severe shivering can be the first warning of dangerous exposure to cold.

Maximum severe shivering develops when the body temperature has fallen to 95° F. This must be taken as a sign of danger and exposure to cold must be immediately terminated. Productive physical and mental work is limited when severe shivering occurs.

#### Methods to Prevent Cold Stress

When the ambient temperature, or a wind chill equivalent, falls to below 40° F (American Conference of Governmental Industrial Hygienists recommendation), site personnel who must remain outdoors should wear insulated coveralls, insulated boot liners, hard hat helmet liners and insulated hand protection. Wool mittens are more efficient insulators than gloves. Keeping the head covered is very important, since 40% of body heat can be lost when the head is exposed. If it is not necessary to wear a hard hat, a wool knit cap provides the best head protection. A facemask may also be worn.

Persons should dress in several layers rather than one single heavy outer garment. The outer piece of clothing should ideally be wind and waterproof. Clothing made of thin cotton fabric or synthetic fabrics such as polypropylene is ideal since it helps to evaporate sweat. Polypropylene is best at wicking away moisture while still retaining its insulating properties. Loosely fitting clothing also aids in sweat evaporation. Denim is not a good protective fabric. It is loosely woven which allows moisture to penetrate. Socks with a high wool content are best. If two pairs of socks are worn, the inner sock should be smaller and made of cotton, polypropylene or a similar type of synthetic material that wicks away moisture. If clothing becomes wet, it should be taken off immediately and a dry set of clothing put on.

If wind conditions become severe, it may become necessary to shield the work area temporarily. The SSO and the PM will determine if this type of action is necessary. Heated break trailers or a designated area that is heated should be available if work is performed continuously in the cold at temperatures, or equivalent wind chill temperatures, of 20° F.

Dehydration occurs in the cold environment and may increase the susceptibility of the worker to cold injury due to significant change in blood flow to the extremities. Drink plenty of fluids, but limit the intake of caffeine.

### 5.11.2 Heat Stress

#### Types of Heat Stress

Heat related problems include **heat rash**, **fainting**, **heat cramps**, **heat exhaustion** and **heat stroke**. **Heat rash** can occur when sweat isn't allowed to evaporate, leaving the skin wet most of the time and making it subject to irritation. **Fainting** may occur when blood pools to lower parts of the body and as a result, does not return to the heart to be pumped to the brain. Heat related fainting often occurs during activities that require standing erect and immobile in the heat for long periods of time. **Heat cramps** are painful spasms of the muscles due to excessive salt loss associated with profuse sweating. **Heat exhaustion** results from the loss of large amounts of fluid and excessive loss of salt from profuse sweating. The skin will be clammy and moist and the affected individual may exhibit giddiness, nausea and headache.

**Heat stroke** occurs when the body's temperature regulatory system has failed. The skin is hot, dry, red and spotted. The affected person may be mentally confused and delirious. Convulsions could occur. **EARLY RECOGNITION AND TREATMENT OF HEAT STROKE ARE THE ONLY MEANS OF PREVENTING BRAIN DAMAGE OR DEATH.** A person exhibiting signs of heat stroke should be removed from the work area to a shaded area. The person should be soaked with water to promote evaporation. Fan the person's body to increase cooling.

#### Early Symptoms of Heat-Related Health Problems:

- decline in task performance
- incoordination
- decline in alertness
- unsteady walk
- excessive fatigue
- reduced vigilance
- muscle cramps
- dizziness

#### Susceptibility to Heat Stress Increases due to:

- lack of physical fitness
- lack of acclimation
- obesity
- drug or alcohol use

- 
- increased age
  - sunburn
  - dehydration
  - infection

People unaccustomed to heat are particularly susceptible to heat fatigue. First timers in PPE need to gradually adjust to the heat.

### The Effect of Personal Protective Equipment

Sweating normally cools the body as moisture is removed from the skin by evaporation. However, the wearing of certain personal protective equipment (PPE), particularly chemical protective coveralls (e.g., Tyvek), reduces the body's ability to evaporate sweat and thereby regulate heat buildup. The body's efforts to maintain an acceptable temperature can therefore become significantly impaired by the wearing of PPE.

### Measures to Avoid Heat Stress:

The following guidelines should be adhered to when working in hot environments:

- Establish work-rest cycles (short and frequent are more beneficial than long and seldom).
- Identify a shaded, cool rest area.
- Rotate personnel, alternative job functions.
- Water intake should be equal to the sweat produced. Most workers exposed to hot conditions drink less fluids than needed because of an insufficient thirst. **DO NOT DEPEND ON THIRST TO SIGNAL WHEN AND HOW MUCH TO DRINK.** For an 8-hour workday, 50 ounces of fluids should be drunk.
- Eat lightly salted foods or drink salted drinks such as Gatorade to replace lost salt.
- Save most strenuous tasks for non-peak heat hours such as the early morning or at night.
- Avoid alcohol during prolonged periods of heat. Alcohol will cause additional dehydration.
- Avoid double shifts and/or overtime.

The implementation and enforcement of the above mentioned measures will be the joint responsibility of the project manager, on-site field coordinator, and health and safety officer. Potable water and fruit juices should be made available each day for the field team.

### Heat Stress Monitoring Techniques

Site personnel should regularly monitor their heart rate as an indicator of heat strain by the following method: Check radial pulse rates by using fore-and middle fingers and applying light pressure to the pulse in the wrist for one minute at the beginning of each rest cycle. If the pulse rate exceeds 110 beat/minute, shorten the next work cycle by one-third and keep the rest period the same. If, after the next rest period, the pulse rate still exceeds 110 beats/minute, shorten the work cycle by one-third.

## 6. Air Monitoring

### 6.1 Direct Reading Instruments

#### Instrument I- RaeSystems Mini-Rae 2000 photoionization detector (PID) with a 10.6 eV lamp

ENSR will use a PID to screen the breathing zone of employees involved with the closure of the CSAs and the investigation of the potential SWMUs for the presence of solvent vapors. If breathing zone concentrations of total volatile organic compounds (VOCs) are sustained at 25 units above background, Level C respiratory protection, as described in Section 7.2, will be donned. This action level is based on the ACGIH TLVs for MIBK and toluene and their reported response to the selected instrument. As MIBK and toluene have the lowest TLVs of all the solvents that may be present, this action limit will also protect employees from potential exposure to the other solvents that may have been used or stored at the facility.

However, when working in the SWMU where DMF may be a possible contaminant of concern, the action limit for donning Level C respiratory protection is 10 units above background.

When working in the areas where diesel fuel and fuel oil may be the contaminants of concern, the action level for donning Level C respiratory protection will be 50 units above background.

The other contaminants of concern, including adipic acid, glycols, and PCBs are non-volatile compounds and therefore do not pose a vapor inhalation hazard. Exposure to adipic acid and PCBs may occur via the inhalation of dusts but the use of direct-push drilling techniques and/or hand augers to collect soil samples will greatly reduce this potential hazard.

---

**Instrument II- RaeSystems Mini-Rae 2000 photoionization detector (PID) with a 11.7 eV lamp**

Due to historical manufacturing activities, vinyl chloride was a constituent of concern during remedial actions at the site. Due to the remedial actions that have taken place at the site, it is unlikely that ENSR will encounter this contaminant during the proposed SWMU investigations. However, as a precautionary measure, ENSR will screen for the presence of vinyl chloride during the proposed SWMU investigation.

Although a MiniRae 2000 with a 10.6 eV lamp can detect the presence of vinyl chloride, the reported response rate is very poor. Given the low PEL of vinyl chloride and its toxicity, it is important to detect the compound efficiently and to the extent possible, by itself, instead of part of a total VOC measurement. The reported response rate of vinyl chloride to a MiniRae 2000 with an 11.7 eV lamp is far better than that of a 10.6 eV lamp. However, the PID with the 11.7 lamp will still detect the other solvents (although less efficiently than a 10.6eV lamp).

Therefore, this unit will be pre-set to read as if it was calibrated to vinyl chloride and will, in theory, provide ENSR with a better way to evaluate the presence of vinyl chloride, by itself, in the work area. When this PID indicates sustained (15 minute) breathing zone vapor concentrations in excess of 1 unit or more, work will cease until engineering controls can be implemented to control the vapors. Note that the odor threshold for vinyl chloride is 3,000 ppm. Therefore, the use of air-purifying respiratory protection is not acceptable. The fact that vinyl chloride is a known human carcinogen also dictates the type of respiratory protection that is accepted by OSHA. If employee exposures exceed the action level, air-supplying respiratory protection would be required. Therefore, engineering controls will be implemented first.

**Instrument III – Carbon Monoxide Meter**

If internal combustion engines are operated inside the facility buildings, a carbon monoxide meter must be used to monitor the build up of exhaust gas in the building. The unit will be set to alarm at 25 ppm. If the alarm sounds, work will cease and all employees will leave the building. Even if the building is well-ventilated and the exhaust gas is ducted to the outside, a CO meter is still required.

**6.2 Personal Air Sampling**

Personal air sampling will not be conducted by ENSR during the activities covered by this HASP.

### 6.3 Calibration and Recordkeeping

Equipment used by ENSR will be calibrated in accordance with the quality assurance plan and ENSR's standard operating procedures. A log of PID readings will be kept in the field notebook. Daily calibration information will also be recorded in the field notebook.

### 6.4 Community Air Monitoring Plan

A community air monitoring plan (CAMP) has been prepared for the SWMU investigation. The CAMP has been prepared as a standalone document along with the workplan. The specifics of the proposed air monitoring are not specified in this HASP but rather only in the CAMP document.

## 7. Personal Protective Equipment

Personal protective equipment (PPE) will be worn during these activities to prevent on-site personnel from being injured by the safety hazards posed by the site and/or the activities being performed. In addition, chemical protective clothing will be worn to prevent direct dermal contact with the site's chemical contaminants. The following table describes the PPE and chemical protective clothing to be worn for general site activities and for certain specific tasks.

### 7.1 Chemical Protective Clothing

This chart has been prepared with the assumption that employees involved in performing or monitoring the tasks listed below will not be working in areas where decommissioning or demolition activities are taking place. Should activities occur simultaneously, it may be necessary for hard hats and hearing protection to be worn at all times. The SSO will determine if this is case by coordinating with all on-site contractors at the beginning of each day.

PPE Item	Task 1	Task 2	Task 3	Task 4	Task 5	Task 6	Task 7
Hard Hat					✓		✓
Rubber Boots			✓				
Steel Toed Safety Shoes	✓	✓		✓	✓	✓	✓
Safety Glasses with Sideshields	✓	✓	✓	✓		✓	✓
Faceshield			✓				✓
Tyvek Coveralls		✓					
Polycoated Tyvek coveralls			✓				

Kevlar gloves					*		✓
Inner PVC/Outer Nitrile Gloves	✓	✓	✓	✓	✓	✓	
Hearing Protection					✓		✓

No special PPE is required to conduct the GPR survey

Task 1 – CSA Inspection

Task 2 – Manual Removal of Residues from CSAs Surfaces

Task 3 – Steam Cleaning of CSAs Surfaces

Task 4 – Sampling Rinseate from CSA Closure Activities

Task 5 – Soil Sampling with Geoprobe

\* -wear when using knife to open acetate liner

Task 6 – Soil Sampling with Hand Auger

Task 7 – Concrete Coring with Rock Hammer or Jackhammer

## 7.2 Respiratory Protection

Respiratory protection will be in worn in accordance with the limits defined in the table below:

Contaminant	Action Limit	Response
Solvents	25 units in the breathing zone (sustained for 15-minutes)	Don half-mask, air-purifying respirators with organic vapor cartridges
Fuel Oil/Diesel Fuel	50 units in the breathing zone (sustained for 15-minutes)	Don half-mask, air-purifying respirators with organic vapor cartridges
DMF	10 units in the breathing zone (sustained for 15 minutes)	Don half-mask, air-purifying respirators with organic vapor cartridges
Carbon Monoxide	25 ppm in work area	Cease work. Return when exhaust has subsided. If



		gases are not controlled, mobilize mechanical ventilation. LEVEL C RESPIRATORY PROTECTION IS NOT EFFECTIVE
Vinyl chloride	1 unit in breathing zone (sustained for 15 minutes) or 5 units at any time	Cease work. Contact PM. Mobilize ventilation equipment or supplied air respiratory equipment

### 7.3 Other Protective Equipment

The following additional safety items should be available at the site for ENSR use:

- Portable, hand-held eyewash bottles
- First aid kit
- *Portable communications equipment*

The location of other emergency equipment such as hard-plumbed eyewash stations, emergency drenching showers, fire extinguishers and spill kits should be reviewed with Bayer representatives upon arrival to the site and entry into each new work area.

## 8. Site Control

To prevent both exposure of unprotected personnel and migration of contamination due to tracking by personnel or equipment, work areas along with personal protective equipment requirements will be clearly identified.

### 8.1 Designation of Zones

ENSR designates work areas or zones as suggested in the "Occupational Safety and Health Guidance Manual for Hazardous Waste Site Activities," NIOSH/OSHA/USCG/EPA, November, 1985. They recommend the areas surrounding each of the work areas to be divided into three zones:

- Exclusion or "hot" Zone
- Contamination Reduction Zone (CRZ)
- Support Zone

### **8.1.1 Exclusion Zone**

An exclusion zone will be established around each of the drilling locations. Each zone will be demarcated with either traffic cones or hazard tape. All personnel entering these areas must wear the prescribed level of protective equipment. When working in the CSAs, the rooms themselves can be cordoned off to limit access to these work areas.

### **8.1.2 Contamination Reduction Zone**

Mini-decontamination zones will be established adjacent to each work area. Personnel will remove contaminated gloves and other disposable items in this area and place them in a plastic bag until they can be properly disposed of.

### **8.1.3 Support Zone**

At this site the support zone will include the area outside of the work area.

## **8.2 Safety Practices**

The following measures are designed to augment the specific health and safety guidelines provided in this plan.

- The "buddy system" will be used at all times by all field personnel. No one is to perform field work alone. Standby team member must be intimately familiar with the procedures for initiating an emergency response.
- Eating, drinking, chewing gum or tobacco, smoking or any practice that increases the probability of hand-to-mouth transfer and ingestion of materials is prohibited in the immediate work area and the decontamination zone.
- Smoking is prohibited in all work areas. Matches and lighters are not allowed in these areas.
- Hands and face must be thoroughly washed upon leaving the work area and before eating, drinking or any other activities.
- Beards or other facial hair that interfere with respirator fit are prohibited.
- The use of alcohol or illicit drugs is prohibited during the conduct of field operations.

- 
- All equipment must be decontaminated or properly discarded before leaving the site in accordance with the project work plan.

---

## 9. Decontamination

### 9.1 Personal Decontamination

Proper decontamination is required of all ENSR personnel before leaving the site. Decontamination will occur within the contamination reduction zone. Disposable PPE will be removed in the decontamination zone and placed in lined garbage bags.

If worn, respirators will be cleaned after each use with respirator wipe pads and will be stored in plastic bags after cleaning.

### 9.2 Sanitation

ENSR employees will have access to Bayer's restroom and hand-washing facilities.

## **10. Medical Monitoring and Training Requirements**

### **10.1 Medical Monitoring**

All personnel performing activities covered by this HASP must be active participants in a medical monitoring program that complies with 29 CFR 1910.120(f). Each individual must have completed an annual surveillance examination and/or an initial baseline examination within the last year prior to performing any work on the site covered by this HASP.

### **10.2 Health and Safety Training**

#### **10.2.1 HAZWOPER**

All personnel performing activities covered by this HASP must have completed the appropriate training requirements specified in 29 CFR 1910.120(e). Each individual must have completed an annual 8-hour refresher-training course and/or initial 40-hour training course within the last year prior to performing any work on the sites covered by this HASP.

#### **10.2.2 Pre-Entry Briefing**

The SSO will conduct a pre-entry briefing before site activities begin. HASP receipt and acceptance sheets will be collected at this meeting. Short safety refresher meetings will be conducted, as needed, throughout the duration of the project. Attendance of the pre-entry meeting is mandatory and will be documented by the ENSR SSO. An attendance form is presented in Attachment B.

#### **10.2.3 Bayer Facility Safety Orientation**

ENSR employees may be required to participate in a facility safety orientation. If such an orientation is not required by Bayer, ENSR should still meet with Bayer representatives to review important emergency information such as existing alarm systems or signals at the plant, evacuation routes, assembly areas for contractors and emergency reporting structure that Bayer requires contractors to follow.

#### **10.2.4 Daily Safety Briefings**

If daily safety meetings are conducted by Bayer and/or the other contractor(s) on-site, ENSR should make every attempt to attend them so they can become familiar with the work scope for the day and any potential hazards associated with the work and the potential impacts to ENSR's work area.

## 11. Emergency Response

OSHA defines emergency response as any "response effort by employees from outside the immediate release area or by other designated responders (i.e., mutual-aid groups, local fire departments, etc.) to an occurrence which results, or is likely to result in an uncontrolled release of a hazardous substance." According to ENSR policy, ENSR personnel shall not participate in any emergency response where there are potential safety or health hazards (i.e., fire, explosion, or chemical exposure). ENSR response actions will be limited to evacuation and medical/first aid as described within this section below. As such this section is written to comply with the requirements of 29 CFR 1910.38 (a).

The basic elements of an emergency evacuation plan include:

- employee training,
- alarm systems,
- escape routes,
- escape procedures,
- critical operations or equipment,
- rescue and medical duty assignments,
- designation of responsible parties,
- emergency reporting procedures and
- methods to account for all employees after evacuation.

### 11.1 Employee Training

Employees must be instructed in the site-specific aspects of emergency evacuation. On-site refresher or update training is required anytime escape routes or procedures are modified or personnel assignments are changed.

### 11.2 Alarm Systems/Emergency Signals

An emergency communication system must be in effect at all sites. The most simple and effective emergency communication system in many situations will be direct verbal communications. Each site must be assessed at the time of initial site activity and periodically as the work progresses. Verbal communications must be supplemented anytime voices can not be clearly perceived above ambient noise levels (i.e., noise from heavy equipment; drilling rigs, backhoes, etc.) and anytime a clear line-of-sight can not be easily maintained amongst all ENSR personnel because of distance, terrain or other obstructions.

Verbal communications will be adequate to warn employees of hazards associated with the immediate work area. Facility telephones area available to ENSR and there is a phone in the office that Bayer has provided to ENSR for the duration of the program. However, ENSR employees will also be equipped with a cellular phone.

### **11.3 Escape Routes and Procedures**

The escape route from the site will be determined upon arrival to the site and verified with Bayer representatives.

### **11.4 Rescue and Medical Duty Assignments**

The phone numbers of the police and fire departments, ambulance service, local hospital, and ENSR representatives are provided in the emergency reference sheet. This sheet will be posted in the site vehicles and the Bayer office that ENSR is working out of.

In the event an injury or illness requires more than first aid treatment, the SSO will accompany the injured person to the medical facility and will remain with the person until release or admittance is determined. The escort will relay all appropriate medical information to the on-site project manager and the RHSM.

If the injured employee can be moved from the accident area, he or she will be brought to the CRZ where their PPE will be removed. If the person is suffering from a back or neck injury the person will not be moved and the requirements for decontamination do not apply. The SSO must familiarize the responding emergency personnel about the nature of the site and the injury. If the responder feels that the PPE can be cut away from the injured person's body, this will be done on-site. If this not feasible, decontamination will be performed after the injured person has been stabilized.

### **11.5 Designation of Responsible Parties**

The SSO is responsible for initiating emergency response. In the event the SSO can not fulfill this duty, the alternate SSO will take charge. All personnel on site are responsible for knowing the escape route from the site and where to assemble after evacuation. The emergency routes and assembly areas will be reviewed with Bayer upon ENSR's arrival to the site and posted in ENSR's office area within the plant.



---

### **11.6 Employee Accounting Method**

The SSO is responsible for identifying all ENSR personnel on-site at all times. On small, short duration jobs this can be done informally as long as accurate accounting is possible. On all other sites a formal log-in and log-out procedure must be implemented. In the event of a facility-wide evacuation, the ENSR SSO will communicate the head-count results to the Bayer representative in charge.

### **11.7 Accident Reporting and Investigation**

Any incident (other than minor first aid treatment) resulting in injury, illness to an ENSR employee requires an accident investigation and report. The investigation should be conducted as soon as emergency conditions are under control. The purpose of the investigation is not to attribute blame but to determine the pertinent facts so that repeat or similar occurrences can be avoided. An ENSR accident investigation form is presented in Attachment C of this HASP. The injured ENSR employee's supervisor and the RHSM should be notified immediately of the injury.

---

**EMERGENCY REFERENCES**

**Ambulance:** 911

**Fire:** 911

**Police:** 911

**Medical Services:** 516-719-3000

North Shore University Hospital  
888 Old Country Rd  
Plainview, NY

**Directions to Hospital:** Head north on New South Rd from the site. Turn right onto E. Old Colony Rd. Continue onto Old Country Rd. Hospital is approximately 2 miles from facility.

**On Site Telephone:** ENSR has an office at the facility that is equipped with the phone. ENSR on-site employees are also equipped with *cellular phones*.

---

**ENSR Project Representatives:**

ENSR/WESTFORD, MA 978-589-3000

-Kathleen Harvey (RHSM) x 3325

ENSR/PITTSBURGH, PA 412-261-2910

-Frank Myerski (PM)

**BAYER Project Representatives:**

-Joel Robinson – Manager, Solid Waste and Remediation Programs  
(412) 303-5742 cell phone

**MAP SHOWING DIRECTIONS FROM BAYER TO NORTH SHORE UNIVERSITY HOSPITAL**

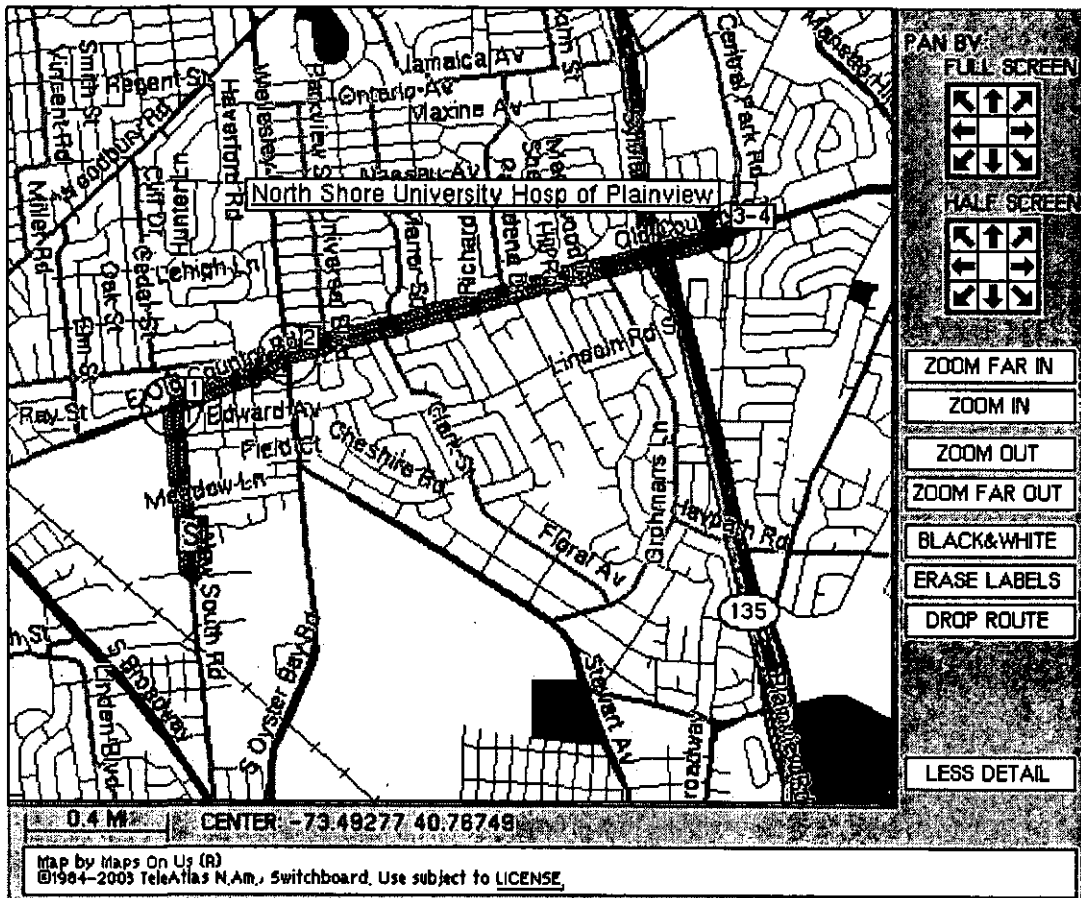

HASP - CSA Closure & SWMU Investigation  
 Bayer Corporation Hicksville Polymers Plant  
 Hicksville, New York

December 2002  
 Revised July 2003

**Attachment A**

**Health and Safety Plan Receipt and Acceptance Form**

---

**Health and Safety Plan Receipt and Acceptance Form**

**Closure of the Less than 90-Day Container Storage Areas  
&  
Investigation of Solid Waste Management Units  
Bayer Corporation Hicksville Polymer Plant  
Hicksville, New York**

I have received a copy of the Health and Safety Plan prepared for the above-referenced site and activities. I have read and understood its contents and I agree that I will abide by its requirements.

Name (Print) \_\_\_\_\_

Signature \_\_\_\_\_ Date: \_\_\_\_\_

Representing (Print) \_\_\_\_\_  
Company Name

**Attachment B**

**Health and Safety Plan Pre-Entry Briefing Attendance Form**



**Health and Safety Plan Pre-Entry Briefing Attendance Form**

Closure of the Less than 90-Day Container Storage Areas  
 &  
 Investigation of Solid Waste Management Units  
 Bayer Corporation Hicksville Polymer Plant  
 Hicksville, New York

Briefing Conducted By: \_\_\_\_\_

Date Performed: \_\_\_\_\_

Printed Name	Signature	Representing

HASP – CSA Closure & SWMU Investigation  
 Bayer Corporation Hicksville Polymers Plant  
 Hicksville, New York

December 2002  
 Revised July 2003

---

**Attachment C**

**Supervisor's Accident Investigation Report Form**



**SUPERVISOR'S ACCIDENT INVESTIGATION REPORT**

Injured Employee \_\_\_\_\_ Job Title \_\_\_\_\_

Home Office \_\_\_\_\_ Division/Department \_\_\_\_\_

Date/Time of Accident \_\_\_\_\_

Location of Accident \_\_\_\_\_

Witnesses to the Accident \_\_\_\_\_

Injury Incurred? \_\_\_\_\_ Nature of Injury \_\_\_\_\_

Engaged in What Task When Injured? \_\_\_\_\_

Will Lost Time Occur? \_\_\_\_\_ How Long? \_\_\_\_\_ Date Lost Time Began \_\_\_\_\_

Were Other Persons Involved/Injured? \_\_\_\_\_

How Did the Accident Occur? \_\_\_\_\_

What Could Be Done to Prevent Recurrence of the Accident? \_\_\_\_\_

What Actions Have You Taken Thus Far to Prevent Recurrence? \_\_\_\_\_

Supervisor's Signature \_\_\_\_\_ Title \_\_\_\_\_ Date \_\_\_\_\_

Reviewer's Signature \_\_\_\_\_ Title \_\_\_\_\_ Date \_\_\_\_\_

**Note: If the space provided on this form is insufficient, provide additional information on a separate page and attach. The completed accident investigation report must submitted to the Regional Health and Safety Manager within two days of the occurrence of the accident.**

New York State Department of Health  
Generic Community Air Monitoring Plan

A Community Air Monitoring Plan (CAMP) requires real-time monitoring for volatile organic compounds (VOCs) and particulates (i.e., dust) at the downwind perimeter of each designated work area when certain activities are in progress at contaminated sites. The CAMP is not intended for use in establishing action levels for worker respiratory protection. Rather, its intent is to provide a measure of protection for the downwind community (i.e., off-site receptors including residences and businesses and on-site workers not directly involved with the subject work activities) from potential airborne contaminant releases as a direct result of investigative and remedial work activities. The action levels specified herein require increased monitoring, corrective actions to abate emissions, and/or work shutdown. Additionally, the CAMP helps to confirm that work activities did not spread contamination off-site through the air.

The generic CAMP presented below will be sufficient to cover many, if not most, sites. Specific requirements should be reviewed for each situation in consultation with NYSDOH to ensure proper applicability. In some cases, a separate site-specific CAMP or supplement may be required. Depending upon the nature of contamination, chemical-specific monitoring with appropriately-sensitive methods may be required. Depending upon the proximity of potentially exposed individuals, more stringent monitoring or response levels than those presented below may be required. Special requirements will be necessary for work within 20 feet of potentially exposed individuals or structures and for indoor work with co-located residences or facilities. These requirements should be determined in consultation with NYSDOH.

Reliance on the CAMP should not preclude simple, common-sense measures to keep VOCs, dust, and odors at a minimum around the work areas.

Community Air Monitoring Plan

Depending upon the nature of known or potential contaminants at each site, real-time air monitoring for volatile organic compounds (VOCs) and/or particulate levels at the perimeter of the exclusion zone or work area will be necessary. Most sites will involve VOC and particulate monitoring; sites known to be contaminated with heavy metals alone may only require particulate monitoring. If radiological contamination is a concern, additional monitoring requirements may be necessary per consultation with appropriate NYSDEC/NYSDOH staff.

Continuous monitoring will be required for all ground intrusive activities and during the demolition of contaminated or potentially contaminated structures. Ground intrusive activities include, but are not limited to, soil/waste excavation and handling, test pitting or trenching, and the installation of soil borings or monitoring wells.

Periodic monitoring for VOCs will be required during non-intrusive activities such as the collection of soil and sediment samples or the collection of groundwater samples from existing monitoring wells. "Periodic" monitoring during sample collection might reasonably consist of

taking a reading upon arrival at a sample location, monitoring while opening a well cap or overturning soil, monitoring during well baling/purging, and taking a reading prior to leaving a sample location. In some instances, depending upon the proximity of potentially exposed individuals, continuous monitoring may be required during sampling activities. Examples of such situations include groundwater sampling at wells on the curb of a busy urban street, in the midst of a public park, or adjacent to a school or residence.

VOC Monitoring, Response Levels, and Actions

Volatile organic compounds (VOCs) must be monitored at the downwind perimeter of the immediate work area (i.e., the exclusion zone) on a continuous basis or as otherwise specified. Upwind concentrations should be measured at the start of each workday and periodically thereafter to establish background conditions. The monitoring work should be performed using equipment appropriate to measure the types of contaminants known or suspected to be present. The equipment should be calibrated at least daily for the contaminant(s) of concern or for an appropriate surrogate. The equipment should be capable of calculating 15-minute running average concentrations, which will be compared to the levels specified below.

- If the ambient air concentration of total organic vapors at the downwind perimeter of the work area or exclusion zone exceeds 5 parts per million (ppm) above background for the 15-minute average, work activities must be temporarily halted and monitoring continued. If the total organic vapor level readily decreases (per instantaneous readings) below 5 ppm over background, work activities can resume with continued monitoring.
- If total organic vapor levels at the downwind perimeter of the work area or exclusion zone persist at levels in excess of 5 ppm over background but less than 25 ppm, work activities must be halted, the source of vapors identified, corrective actions taken to abate emissions, and monitoring continued. After these steps, work activities can resume provided that the total organic vapor level 200 feet downwind of the exclusion zone or half the distance to the nearest potential receptor or residential/commercial structure, whichever is less - but in no case less than 20 feet, is below 5 ppm over background for the 15-minute average.
- If the organic vapor level is above 25 ppm at the perimeter of the work area, activities must be shutdown.

All 15-minute readings must be recorded and be available for State (DEC and DOH) personnel to review. Instantaneous readings, if any, used for decision purposes should also be recorded.

Particulate Monitoring, Response Levels, and Actions

Particulate concentrations should be monitored continuously at the upwind and downwind perimeters of the exclusion zone at temporary particulate monitoring stations. The particulate

monitoring should be performed using real-time monitoring equipment capable of measuring particulate matter less than 10 micrometers in size (PM-10) and capable of integrating over a period of 15 minutes (or less) for comparison to the airborne particulate action level. The equipment must be equipped with an audible alarm to indicate exceedance of the action level. In addition, fugitive dust migration should be visually assessed during all work activities.

- If the downwind PM-10 particulate level is 100 micrograms per cubic meter ( $\text{mcg}/\text{m}^3$ ) greater than background (upwind perimeter) for the 15-minute period or if airborne dust is observed leaving the work area, then dust suppression techniques must be employed. Work may continue with dust suppression techniques provided that downwind PM-10 particulate levels do not exceed  $150 \text{ mcg}/\text{m}^3$  above the upwind level and provided that no visible dust is migrating from the work area.
- If, after implementation of dust suppression techniques, downwind PM-10 particulate levels are greater than  $150 \text{ mcg}/\text{m}^3$  above the upwind level, work must be stopped and a re-evaluation of activities initiated. Work can resume provided that dust suppression measures and other controls are successful in reducing the downwind PM-10 particulate concentration to within  $150 \text{ mcg}/\text{m}^3$  of the upwind level and in preventing visible dust migration.

All readings must be recorded and be available for State (DEC and DOH) personnel to review.

June 20, 2000

**APPENDIX D**

**ENSR SOPs**

---

**SOP #7110**

**Surface Soil Sampling**

---

**SOP NUMBER: 7110****Surface Soil Sampling****Date:** 2003**Revision Number:** 04690-079**Author:** Charlie Martin**Discipline:** Geosciences**1.0 PURPOSE AND APPLICABILITY****1.1 Purpose and Applicability**

This standard operating procedure (SOP) describes the methods used for obtaining surface soil samples for physical and/or chemical analysis. For purposes of this SOP, surface soil (including shallow subsurface soil) is loosely defined as soil that is present within 5 feet of the ground surface and can be sampled with the use of readily available and easy-to-operate sampling equipment. Various types of sampling equipment are used in the collection of surface soil samples and include spoons or scoops, trowels, shovels, and hand or bucket augers.

The purpose of this SOP is to provide a specific method and/or procedure to be used in the collection of surface soil samples which, if followed properly, will promote consistency in sampling and provide a basis for sample representativeness.

This SOP is generally applicable to surface and shallow depth soils which are unconsolidated and are of low to moderate density. Higher density or compacted soils may require use of drill rigs or other powered equipment to effectively obtain representative samples.

It should be noted that other specific state and/or federal agency standard operating procedures may be in existence in certain areas which may require deviation from this sampling procedure. The applicability of other agency operating procedures, which may differ from ENSR's SOP, needs to be determined prior to start of the sampling program. Deviations from this SOP to accommodate other regulatory requirements should be reviewed in advance of the field program, should be explained in the project work plan, and must be documented in the field project notebook when they occur.

**1.2 General Principles**

Surface soil sampling generally involves use of hand-operated equipment to obtain representative soil samples from the ground surface and to shallow depths below the ground surface. If soil conditions are appropriate, surface soil sampling, following the

procedures described in this SOP, can provide representative soil samples in an efficient manner.

### **1.3 Quality Assurance Planning Considerations**

Project personnel should follow specific quality assurance guidelines for sampling as outlined in the site-specific QAPP and/or Sampling Plan. Proper quality assurance requirements should be provided which will allow for collection of representative samples from representative sampling points. Quality assurance requirements typically suggest the collection of a sufficient quantity of field duplicate, field blank, and equipment blank samples.

### **1.4 Health and Safety Considerations**

Surface soil sampling may involve chemical exposure hazards associated with the type of contaminants present in surface soil. When surface soil sampling is performed, adequate Health and Safety measures must be taken to protect sampling personnel. These measures must be addressed in the project Health and Safety Plan (HASP). This plan must be approved by the project Health and Safety Officer before work commences, must be distributed to all personnel performing sampling, and must be adhered to as field activities are performed.

## **2.0 RESPONSIBILITIES**

### **2.1 Sampling Personnel**

It will be the responsibility of the sampling personnel to conduct surface soil sampling in a manner consistent with this SOP. The above individual will be responsible for the proper use and maintenance of all types of equipment used for obtaining surface soil samples, and the collection, labeling, handling and storage of all samples until further chain-of-custody procedures are undertaken.

### **2.2 Sampling Coordinator**

Large sampling programs may require additional support personnel such as a sampling coordinator. The sampling coordinator is responsible for providing management support such as maintaining an orderly sampling process, providing instructions to sampling personnel regarding sampling locations, and fulfilling sample documentation requirements, thereby allowing sampling personnel to collect samples in an efficient manner.



### 2.3 Project Manager

It is the responsibility of the project manager to ensure that the sampling activity is properly staffed, planned, and executed.

## 3.0 REQUIRED MATERIALS

### 3.1 Spoons or Scoops

Spoons or scoops should preferably be constructed of stainless steel as this material is abrasion resistant, can be easily decontaminated, and can be used to manually extract low to moderate density soil samples directly from the ground surface. Other spoon/scoop construction materials such as high-density polyethylene and teflon may be suitable in some applications but are difficult to use in higher density soils.

### 3.2 Trowel

Stainless steel construction is preferred. The blade of a trowel is generally flat or slightly curved and is 5 to 6 inches in length. Some trowels are available with depth calibrations marked on the blade.

### 3.3 Shovel

Shovels may be long or short-handled and are most often used for preparation of the sample collection area, i.e., for removal of surface debris or penetration of a high density/compacted surface prior to collection of the sample with another more appropriate device. Shovels may be used for the collection of samples that require large volumes of material for analysis (i.e., for bench-scale treatability studies). Shovels can also be used for scraping of test pit sidewalls in preparation for sidewall sampling using another device.

### 3.4 Hand Auger

This tool, commonly referred to as a soil auger, consists of a short spiral-bladed metal rod (solid-stem auger) attached to a handle. Clockwise rotation of the handle provides the cutting motion for the auger. Most of the loose soil is discharged upwards as the auger moves downwards. However, if the soil is cohesive some of it will stick to the auger flight providing a collectable sample at a measurable depth. Samples of surface soil can also be collected using a tube sampler which is attached to the end of the auger rods and advanced into the soil to extract a sample.

### 3.5 Bucket Auger

This device consists of a short length of hollow tube with cutting teeth at the bottom. As the handle is rotated, the sample is brought into and retained within the tube. When the auger is removed from the ground surface, the sample is retrieved from the tube with a spoon, or, if loosely consolidated, is poured directly into a collection pan or into the sample containers. Typically constructed of stainless steel, bucket augers are commonly available in diameters varying from two to four inches.

### 3.6 Collection Pan

A soil collection pan is often used as an intermediate sample container between removal of the sample from the ground and final bottling of the sample. Soil collection pans should preferably be constructed of stainless steel, although common household steel cooking pans may be used if the pan is lined with aluminum foil during sample collection. Additionally, single-use, disposable aluminum pans may be used for individual samples, though they can not be decontaminated sufficiently for re-use.

### 3.7 Supporting Materials

- Teaspoon or spatula
- Aluminum foil
- Sample kit (i.e., bottles, labels, custody records, cooler, etc.)
- Sample logs/boring logs
- Decontamination materials
- Six-foot folding rule or tape measure for depth measurement
- Personal protective equipment (as required by the HASP)
- Field project notebook/pen

## 4.0 METHOD

### 4.1 General Procedures

Site-specific soil characteristics such as soil density and moisture will generally dictate the preferred type of sampling equipment for use at a particular site. Similarly, other project-specific requirements such as sampling depth and requested type of analysis such as physical testing (e.g., grain-size distribution) and/or chemical analysis will dictate the use of a preferred type of sampling equipment. Analytical testing requirements will indicate sample volume requirements that also will influence the selection of the appropriate type of sampling tool. The project sampling plan should define the specific requirements for collection of surface soil samples at a particular site.

Should site-specific characteristics remain unidentified prior to start of the sampling program, sampling personnel should be equipped with a variety of sampling equipment to address the most likely sampling situations to be encountered.

As indicated, sample volume and sampling depth requirements should be defined in the sampling plan. This information should define the size of the hole which will be created during collection of the sample. For instance, if only a 500-ml sample will be required for analysis from a depth interval of 0 to 6 inches, an approximate 2 to 3-inch diameter hole will be needed. The indicated types of sampling equipment will generally make a minimum diameter hole of approximately 3 inches, therefore, an excess volume of soil may be generated during collection of a small volume soil sample. For samples requiring a large volume of soil, multiple holes and soil compositing may be necessary. Collection of the requisite volume of soil to meet sample volume requirements without underestimating the sample volume is the overall objective and is a technique which improves with experience.

It should be noted that some sampling programs may require the use of a sampling grid for the purpose of obtaining a statistically representative number of soil samples. This SOP does not provide information relative to construction of a sampling grid. This information may be found in other documents.

#### 4.2 Equipment Decontamination

Regardless of the specific type of equipment used, each piece of equipment needs to be decontaminated prior to its initial use and following collection of each individual soil sample. Site-specific requirements for equipment decontamination should be outlined within the project sampling plan. Equipment decontamination procedures are specified within ENSR SOP 7600 - Decontamination of Equipment.

#### 4.3 Collection of Samples for Volatile Organics Analysis

Collection of surface soil samples for volatile organics analysis (VOA) is different than collection of soil samples for other routine physical or chemical testing primarily because of the concern for potential loss of volatiles during the normal sample collection procedure. To limit the potential for loss of volatiles, the soil sample must be obtained as quickly and as directly as possible. This generally means that if a VOA sample is to be collected as part of a multiple analyte sample, the VOA sample portion should be obtained first. The VOA sample should also be obtained from a discrete portion of the entire collected sample and not from a sample which has been composited or homogenized from the entire sample interval. In general, it is best to collect the VOA sample by transferring the sample directly from the sampling tool into the sample bottles.

Intermediate sample containers such as collection pans should not be used during collection of VOA samples.

#### 4.4 Standard Procedures

##### 4.4.1 Surface Preparation

At some sampling locations, the ground surface may require preparation in advance of sampling. Surface preparation can include removal of surface debris which blocks access to the actual soil surface or loosening of dense surface soils such as those encountered in heavy traffic areas, or frozen soils. If sampling equipment is used for both removal of surface debris and for collection of the soil sample, the equipment should be decontaminated prior to sample collection to reduce the potential for sample interferences between the surface debris and the underlying soil.

##### 4.4.2 Shovel Sampling Procedure

A detailed operating procedure for proper use of a shovel for soil sampling is unnecessary. Specific requirements for sample quantity and sampling depth should be outlined within the project sampling plan.

Decontaminate the shovel in accordance with established procedures prior to use.

Once the soil sample is obtained and placed into the appropriate sample container(s) the hole from which the sample was retrieved should be filled with surrounding soils to eliminate a potential surface hazard.

##### 4.4.3 Spoon, Scoop, and Trowel Sampling Procedure

Spoons, scoops, and trowels are of similarly designed construction and can therefore be operated in accordance with the following procedure.

Select the sampling location and prepare the surface by removal of surface debris if present. If the sample depth interval is at some depth below the ground surface, the surface soil material should also be removed as part of the surface preparation step. Surface preparation should be completed using other appropriately decontaminated sampling equipment.

Decontaminate the sampling tool in accordance with established procedures prior to use.

The soil sample should be obtained by inserting the sampling tool into the ground and rotating the tool so that a representative "column" of soil is removed from the ground.

The immediate objective is to collect the VOA sample fraction first if this is required. If the VOA sample is to be collected from the upper sampling interval, then the first scoop of soil should be used to directly fill the sample containers. If a specific depth below the ground surface has been targeted for the VOA sample, the overlying soils should be removed and discarded or placed into a soil collection pan as part of the remaining composite sample.

Regardless of whether or not a VOA sample is required, one or more cores or scoops of soil may be needed until the desired sampling depth is achieved. Removal of a representative column of soil in cohesionless soils may be difficult to achieve, however. If more soil is needed to meet sample volume requirements, additional soil cores may be collected from an immediately adjacent location.

Except for VOA samples, as each portion of the sample is removed from the ground, it should be placed into an intermediate sample container (collection pan) until the entire sample interval of soil is removed.

Once the sample interval has been collected, the soil sample should be thoroughly homogenized within the collection pan prior to bottling. Sample homogenizing is accomplished by manually mixing the entire soil sample in the collection pan with the sampling tool or with a clean teaspoon, scoop or spatula until a uniform mixture is achieved.

The appropriate sample containers should be filled with soil from the collection pan. The sampling tool may be used to fill the sample bottles. If packing of the samples into the bottles is necessary, a clean stainless steel teaspoon or spatula may be used. Use of fingers/hands to fill or pack sample containers should be avoided (this also includes VOA samples).

Once each sample container is filled, the rim and threads of the sample container will be cleaned of gross soil by wiping with a paper towel, then capped and labeled. Do not submerge the sample containers in water to clean them. Once labeled the sample containers should be placed into a cooler for protection. Sample chain-of-custody and other documentation requirements should be completed at this time.

The sampling tool and other sampling equipment should be decontaminated prior to reuse. All investigation-derived waste should be properly contained before leaving the area.

The sample hole should be backfilled to eliminate any surface hazard. The project sampling plan may indicate the requirements for backfilling of the sample hole.

#### 4.4.4 Hand Auger Sampling

Select the sampling location and prepare the surface by removal of surface debris if present.

Decontaminate the sampling tool in accordance with established procedures prior to use.

A hand auger, or soil auger, can be used to extract shallow soil samples up to three (3) feet below the surface. Representative samples can be collected directly from the auger flight as it is withdrawn from the ground, or from the tube sampler attachment which can be advanced into the soil after augering to the desired depth.

When using the hand auger, the hole should be augered to the required depth by manually pushing and turning the auger. As the auger is turned, soils will be discharged to the ground surface, although some soil will be retained on the auger flight. Augering should be continued until the desired depth is achieved. If a composite or homogenized soil sample is the objective, those soils which have been discharged to the ground surface as well as those soils which cling to the auger flight should be homogenized within a soil collection pan prior to bottling. If a VOA sample is required, this fraction of the soil sample should be collected as soon as possible without compositing. It should be noted that soil augers cause considerable disturbance of the soil, therefore, some consideration should be given toward collection of VOA sample fractions using some other method (spoons, trowels, bucket augers may cause less disturbance).

Except for VOA sample fractions, the remainder of the soil sample should be thoroughly homogenized in the soil collection pan prior to bottling.

The appropriate sample containers should be filled with soil from the collection pan. A clean spoon or spatula may be needed to fill the sample bottles as necessary.

Once each sample container is filled, the rim and threads of the sample container will be cleaned of gross soil by wiping with a paper towel, then capped and labeled. Do not submerge the sample containers in water to clean them. Once labeled the sample containers should be placed into a cooler for protection. Sample chain-of-custody and other documentation requirements should be completed at this time.

All used sampling equipment should be decontaminated prior to reuse and investigation-derived waste should be properly contained before leaving the area.

The sample hole should be backfilled to eliminate any surface hazard. The project sampling plan may indicate the requirements for backfilling of the sample hole.

#### 4.4.5 Bucket Auger Sampling

A bucket auger may be used to collect soil samples from depths ranging from one (1) to approximately five (5) feet. In some instances, soil samples may be collected from greater depths, but often with considerable more difficulty. Bucket augers allow for discrete depth interval sampling as the soil is retained within the hollow tube of the auger when it is extracted from the ground. It should be noted that if depth-discrete sampling is the objective, more than one auger may be necessary, with one auger used to provide access to the required sampling depth and the other (clean) auger used for sample collection.

Select the sampling location and prepare the surface by removal of surface debris, if present.

Decontaminate the sampling tool in accordance with established procedures prior to use.

When using the bucket auger, the auger should be pushed downward and rotated until the bucket becomes filled with soil. Usually a 6 to 12-inch core of soil is obtained each time the auger is inserted. Once filled, the auger should be removed from the ground and emptied into the soil collection pan. If a VOA sample is required, the sample should be taken directly from the auger using a teaspoon or spatula and/or directly filling the sample container from the auger. The augering process should be repeated until the desired sample interval has been augered and placed into the collection pan.

If the desired sample interval is located at a specific depth below the ground surface, the unwanted interval can be removed with one auger and the soil

discarded. Sample collection can then proceed in normal fashion using a clean auger or following decontamination of the original auger.

Except for VOA sample fractions, the remainder of the soil sample should be thoroughly homogenized in the soil collection pan prior to bottling.

The appropriate sample containers should be filled with soil from the collection pan. Once each sample container is filled, the rim and threads of the sample container will be cleaned of gross soil by wiping with a paper towel, then capped and labeled. Do not submerge the sample containers in water to clean them. Once labeled the sample containers should be placed into a cooler for protection. Sample chain-of-custody and other documentation requirements should be completed at this time.

All used sampling equipment should be decontaminated prior to reuse and investigation-derived waste should be properly contained before leaving the area.

The sample hole should be backfilled to eliminate any surface hazard. The project sampling plan may indicate the requirements for backfilling of the sample hole.

## 5.0 QUALITY CONTROL

Quality control requirements for sample collection are dependent on project-specific sampling objectives. The Quality Assurance Project Plan (QAPP) will provide requirements for sample preservation and holding times, container types, sample packaging and shipment, as well as requirements for the collection of various quality assurance samples such as trip blanks, field blanks, equipment blanks, and field duplicate samples.

## 6.0 DOCUMENTATION

Various forms are required to ensure that adequate documentation is made of the sample collection activities. These forms include:

- Field log books
- Sample collection records
- Chain-of-custody forms
- Shipping labels

The field book will be maintained as an overall log of all samples collected throughout the study. Sample collection records are generated for each sample collected and include specific



information about the sample (Figure 1). Chain-of-custody forms are transmitted with the samples to the laboratory for sample tracking purposes. Shipping labels are required if sample coolers are to be transported to the laboratory by a third party (courier service). Originals and/or copies of these documents will be retained in the appropriate project files.

## 7.0 TRAINING/QUALIFICATIONS

Surface soil sampling is a relatively simple procedure requiring minimal training and a relatively small amount of equipment. It is, however, recommended that initial attempts be supervised by more experienced personnel. Sampling personnel should be health and safety certified as specified by OSHA (29 CFR 1910.120(e)(3)(i)) to work on sites where hazardous materials may be present.

## 8.0 REFERENCES

Not applicable.

**FIGURE 1 Surface Soil Sample Log**

**ENSR.**

**SURFACE SOIL SAMPLE LOG**

Project Number: \_\_\_\_\_ Project Location: \_\_\_\_\_

Sample Point No.: \_\_\_\_\_

Date: \_\_\_\_\_

Time: \_\_\_\_\_

Sample Point Description/Designation: \_\_\_\_\_

\_\_\_\_\_  
\_\_\_\_\_  
\_\_\_\_\_

**SAMPLE COLLECTION**

Equipment Used: \_\_\_\_\_

No. of Samples Collected: \_\_\_\_\_

Container Size: \_\_\_\_\_

Sample Number	Depth	Type of Material	Analyses Requested

**Comments:**  
\_\_\_\_\_  
\_\_\_\_\_  
\_\_\_\_\_

Lab Designation \_\_\_\_\_

Shipping ID Number: \_\_\_\_\_

Collector's Name \_\_\_\_\_

**SOP #7116**

**Subsurface Soil Sampling by Geoprobe® Methods**

---

**SOP NUMBER: 7118**

**Subsurface Soil Sampling by  
Geoprobe™ Methods**

**Date:** 2003  
**Revision Number:** 04690-079  
**Author:** Charles Martin  
**Discipline:** Geoscience

**1.0 INTRODUCTION**

**1.1 Purpose and Applicability**

This Standard Operating Procedure (SOP) describes the methods available for collecting subsurface soil samples using commercially available Geoprobe™ Systems (or other similar vendor) soil probing equipment. Subsurface soil samples may be obtained using this system for purposes of determining subsurface soil conditions and for obtaining soil samples for physical and/or chemical evaluation.

The purpose of this SOP is to provide a description of a specific method or procedure to be used in the collection of subsurface soil samples using the Geoprobe™ system. Subsurface soil is defined as unconsolidated material which may consist of one or a mixture of the following materials: sand, gravel, silt, clay, peat (or other organic soils), and fill material. Subsurface soil sampling, conducted in accordance with this SOP will promote consistency in sampling and provide a basis for sample representativeness.

This SOP covers subsurface soil sampling using Geoprobe™ Systems equipment; specifically, the Macro-Core Soil Sampler. Use of this sampling equipment requires use of the Geoprobe™ hydraulically-powered percussion/probing machine. Geoprobe™ sampling is usually performed by subcontractors, although rental equipment is available for use by trained operators.

The Geoprobe™ sampling methods covered in this SOP are applicable to unconsolidated soil/fill materials and to a maximum recommended depth of approximately 30 feet. Sampling depths are greatly dependent upon soil density as the hydraulically-powered probing unit has power limitations. Sample recovery is also somewhat dependent on grain size as very coarse gravel, cobbles, and boulders will occasionally cause premature refusal of the sampler. It is generally preferable to have some prior knowledge of site soil conditions if sampling activities are proposed where equipment limitations may become a factor.

**1.2 General Principles**

Soil sampling using the Geoprobe™ System requires use of the hydraulically-powered percussion/probing machine and the Macro-Core Soil Sampler. The percussion/probing machine is typically mounted onto the bed of a pickup truck or van so that a stable working platform is established. The percussion/probing machine, through its hydraulic operation, pushes and hammers the soil sampling equipment vertically into the ground within the targeted sampling interval. The soil sampler is then extracted from the ground to recover the sample.

The Macro-Core Sampler (Figure 1) consists of a 45-inch long by 1.5-inch diameter open-ended steel sampling tool with liners made of clear plastic (cellulose acetate butyrate), stainless steel, or teflon. The tool is designed for use in a continuous sampling capacity in an open borehole up to depths of approximately 24 feet. The borehole walls are required to stay open in order to collect a sample from the next depth interval. Once the sampling tool is removed from the ground, the inserted liner containing the soil sample is removed from the tool. The soil sample is then cut from or extracted from the liner. This sampling tool is most often used for soil profiling and collection of larger volume soil samples (1,300 ml).

#### Quality Assurance Planning Considerations

Sampling personnel should follow specific quality assurance guidelines as outlined in the site-specific Quality Assurance Project Plan (QAPP). Proper quality assurance requirements should be provided which will allow for collection of representative samples from representative sampling points. Quality assurance requirements outlined in the QAPP typically suggest the collection of a sufficient quantity of field duplicate, field blank, and other samples.

#### 1.3 Health and Safety Considerations

The health and safety considerations for the site, including both potential physical and chemical hazards, will be addressed in the site-specific Health and Safety Plan (HASP). All field activities will be conducted in conformance to this HASP.

## 2.0 RESPONSIBILITIES

### 2.1 Project Geologist/Engineer

It will be the responsibility of the project geologist/sampling engineer to conduct subsurface soil sampling in a manner which is consistent with this SOP. The project geologist/sampling engineer will observe all activities pertaining to subsurface soil sampling to ensure that the SOP is followed, and to record all pertinent data onto a boring log. It is also the project geologist/sampling engineer's responsibility to

indicate the specific targeted sampling depth or sampling interval to the drilling subcontractor. The project geologist/sampling engineer is also responsible for the collection of representative environmental or stratigraphic characterization samples once the sampling device has been retrieved and opened. Additional sample collection responsibilities include labeling, handling, and storage of samples until further chain-of-custody procedures are implemented.

**2.2 Drilling Subcontractor**

It will be the responsibility of the drilling subcontractor to provide the necessary Geoprobe™ equipment for obtaining subsurface soil samples. This generally includes the truck or ATV-mounted percussion/probing machine and one or more Macro-Core samplers in good operating condition, appropriate liners, and other necessary equipment for borehole preparation and sampling. It is the drilling subcontractor's responsibility to provide and maintain their own boring logs if desired. Equipment decontamination materials should also be provided by the subcontractor and should meet project specifications.

**3.0 REQUIRED MATERIALS**

In addition to those materials provided by the subcontractor, the project geologist/sampling engineer will require:

- Project Sampling Plan, QAPP, and HASP
- Boring Logs
- Teaspoon or spatula
- Sample kit (bottles, labels, custody records and tape, cooler)
- Sample collection pan
- Folding rule or tape measure
- Utility knife for cutting open Macro-Core sleeves
- Equipment decontamination materials (as required by QAPP)
- Health and safety equipment (as required by HASP)
- Field project notebook/pen

Sampling equipment which comes in direct contact with environmental samples during the *sample collection process* should be constructed of stainless steel, teflon, or glass, unless specified otherwise in the Project Sampling Plan or QAPP.

**4.0 METHOD**

**4.1 General Method Description**

Geoprobe™ soil sampling methods generally involve collection of soil samples by driving the sampling tool directly into the ground using the percussion/probing

machine and without the aid of hollow-stem augers or other casing-installed drilling methods. The Macro-Core soil sampler consists of metal tubes of seamless construction which can not be split apart like split-spoons. Liner/sleeve inserts are required in order to extract an intact soil core/sample from the sampling device.

The sampling device operates by being directly pushed/hammered into the ground by the percussion/probing machine. The borehole is created as the sampling device is advanced downward. The Macro-Core Sampler collects samples continuously and requires that an open borehole be maintained for efficient sample recovery.

When the soil sampling device is retrieved from the borehole, the drive head, cutting shoe and/or piston assembly is removed, and the liner insert with sample is removed from the sampling device. The project geologist/sampling engineer is then given access to the sample for whatever purpose is required.

Table 1 summarizes the construction characteristics and sampling attributes of each type of sampler. The appropriate type of sampler should be selected based on project-specific sampling requirements.

**4.2 Equipment Decontamination**

Each sampling device must be decontaminated prior to its initial use and following collection of each soil sample, especially if sampling for analytical testing purposes is conducted. If sampling for soil logging only is conducted, thorough sampler decontamination between samples may not be necessary although sufficient cleansing is necessary for the sampler to operate properly. Site-specific requirements for equipment decontamination should be outlined in the Project Sampling Plan. Equipment decontamination procedures are also outlined within SOP 7600 - Decontamination of Equipment.

**4.3 Sample Containment**

**4.3.1 General**

- The soil sample can be removed from the liner following viewing and/or logging. Non-segmented plastic liners may be cut along their length in order to allow access to the soil sample. Soil screening for volatiles with a photoionization device (PID) or flame ionization device (FID) may be done at this time, or samples may be individually collected and preserved for screening. Segmented metal liners can be manually separated.
- Once the liner has been separated, the soil sample may be extracted from the individual liner segments with a spoon or spatula. Except for volatile organic samples (see below), the soil sample should be

placed into a sample collection pan and homogenized. Place the sample directly into the required sample container.

- Once filled, the sample container should be properly capped, cleaned and labeled. Sample chain-of-custody and preservation procedures should then be initiated.
- Perform equipment decontamination following containment of the sample.

**4.3.2 Volatile Organic Samples**

- Use of teflon liners is preferred when sampling for analysis of volatile organic compounds (VOC) because these liners are more inert. In order to limit the potential for loss of volatiles, the soil sample should be removed from the liner as soon as possible after sample recovery. VOC soil samples should be selected from a central point within the liner unless another specific sample zone has been targeted. The liner should be cut with a knife and the sample immediately extracted and containerized. Clean and label the container and place it into a cooler immediately. Residual sample may then be used to fill other sample or logging requirements.

**5.0 QUALITY CONTROL**

Quality control requirements are dependent on project-specific sampling objectives. The QAPP will provide requirements for equipment decontamination (frequency and materials), sample preservation and holding times, sample container types, sample packaging and shipment, as well as requirements for the collection of various quality assurance samples such as trip blanks, field blanks, equipment blanks, and field duplicate samples.

**6.0 DOCUMENTATION**

Various forms are required to ensure that adequate documentation is made of sample collection activities. These forms include:

- Boring logs
- Field log books
- Sample collection records
- Chain-of-custody records
- Shipping labels

Boring logs (Figure 3) will provide visual and descriptive information for each sample collected and are often the most critical form of documentation generated during a soil sampling program. The field log book is kept as a general log of activities and should not be used in place of the boring log. Occasionally, sample collection records are used to supplement boring logs, especially for environmental samples which have been collected for



laboratory analysis. Chain-of-custody forms are transmitted with the samples to the laboratory for sample tracking purposes. Shipping labels are required if sample coolers are to be transported to the laboratory by a third party (courier service). Original copies of these records should be maintained in the appropriate project files.

## **7.0 REFERENCES**

Geoprobe™ Systems, August 1993, "1993-94 Equipment and Tools Catalog".

**TABLE 1**  
**Geoprobe Systems Soil Sampler Characteristics**

Sampler Type	Length (in.)	Diameter (in.)	Volume (ml)	Sleeve Liner Type	Suitability <sup>1</sup>			
					Soil Logging	Physical Testing	Chemical-Inorganics	Chemical-Organics
Macro-Core	45	1.5	1,300	Acetate	A	A	A	B
				Stainless Steel	B	A	B	A
				Teflon	A	A	A	A
Large Bore	22	1.06	320	Acetate	A	A	A	B
				Brass	B	A	B	B
				Stainless Steel	B	A	B	A
				Teflon	A	A	A	A

<sup>1</sup> A - Preferred suitability  
B - Acceptable suitability

**Figure 1 – Soil Sampling Tools – Macro-Core Sampler - Parts**

**SOIL SAMPLING TOOLS - Macro-Core Sampler - Parts**

**Macro-Core Sampler**

**AT-720 Series**

The sampler features a nickel-plated sample tube that is 48" long x 2.0" in diameter, a hardened tool steel cutting shoe that has a 1.5" diameter opening, and a tapered drive head that fits standard Geoprobe probe rods. The overall length assembled is 51.25". Sample recovery is 45" long x 1.50" diameter (1302 ml) in a PETG liner.

PARTS	
AT-720	MC Cutting Shoe
AT-721	MC Drive Head
AT-722	MC Sample Tube
AT-725	MC PETG (clear plastic) Liner
AT-726	MC Vinyl End Cap
AT-727	MC Shoe Wrench

KITS	
<b>Assembled Macro-Core Sampler*</b>	
Part No. AT-720K	
<i>Includes the following parts:</i>	
(1)	AT-720 MC Cutting Shoe
(1)	AT-721 MC Drive Head
(1)	AT-722 MC Sample Tube
*kit does not include liners and end caps	

LINERS	
AT-725K	MC PETG Liners (pre-flared, clear plastic) Box of 66 only
AT-726K	MC Vinyl End Caps (fit AT-725 liners) Box of 66 pairs (66 red/66 black)

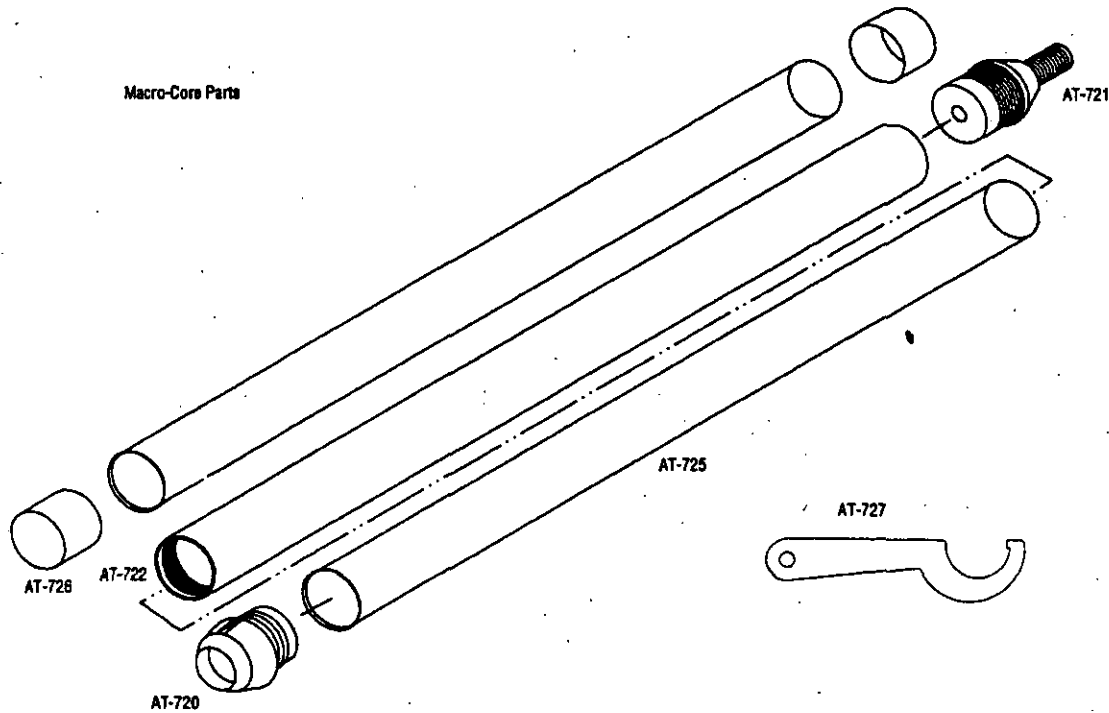

**SOP NUMBER: 7116**

**Figure 3 – Boring Log**



**BORING LOG**

Sheet **1** of

Project No. \_\_\_\_\_ Date - Start \_\_\_\_\_ Finish \_\_\_\_\_ Boring \_\_\_\_\_  
 Project Name \_\_\_\_\_ Drilling Co. \_\_\_\_\_  
 Location \_\_\_\_\_ Drilling Method \_\_\_\_\_  
 Total Depth \_\_\_\_\_ Inspector \_\_\_\_\_ Reviewer \_\_\_\_\_  
 Remarks \_\_\_\_\_

Depth Feet	Sample				Graphic Log	Lithologic Description	Equipment Installed
	Type & No.	Blows per 6 in.	Depth Range	Rec.			

**SOP #7600**

**Decontamination of Field Equipment**

---

SOP NUMBER: 7600

**Decontamination of Field Equipment**

**Date:** 4<sup>th</sup> Qtr. 1994  
**Revision Number:** 4  
**Author:** Charles Martin  
**Discipline:** Geosciences

**1.0 PURPOSE AND APPLICABILITY**

**1.1 Purpose and Applicability**

This SOP describes the methods to be used for the decontamination of field equipment used in the collection of environmental samples. The list of field equipment may include a variety of items used in the collection of soil and/or water samples, such as split-spoon samplers, trowels, scoops, spoons, bailers and pumps. Heavy equipment such as drill rigs and backhoes also require decontamination, usually in a specially constructed temporary decontamination area.

Decontamination is performed as a quality assurance measure and a safety precaution. Improperly decontaminated sampling equipment can lead to misinterpretation of environmental data due to interference caused by cross-contamination. Decontamination protects field personnel from potential exposure to hazardous materials. Decontamination also protects the community by preventing transportation of contaminants from a site.

This SOP emphasizes decontamination procedures to be used for decontamination of reusable field equipment. Occasionally, dedicated field equipment such as well construction materials (well screen and riser pipe) or disposable field equipment (bailers or other general sampling implements) may also require decontamination prior to use. The project-specific work plan should indicate the specific decontamination requirements for a particular project.

Respective state or federal agency (regional offices) regulations may require specific types of equipment or procedures for use in decontamination of field equipment. The project manager should review the applicable regulatory requirements, if any, prior to the start of the field investigation program.

**1.2 General Principles**

Decontamination is accomplished by manually scrubbing, washing, or spraying equipment with detergent solutions, tap water, distilled/deionized water, steam and/or high pressure water, or solvents. The decontamination method and agents

are generally determined on a project-specific basis and must be stated in the Quality Assurance Project Plan (QAPP).

Generally, decontamination of equipment is accomplished at each sampling site between collection points. Waste decontamination materials such as spent liquids and solids will be collected and managed as investigation-derived waste for later disposal. All decontamination materials, including wastes, should be stored in a central location so as to maintain control over the quantity of materials used or produced throughout the investigation program.

### 1.3 Quality Assurance Planning Considerations

#### 1.3.1 General Considerations

Sampling personnel should follow specific quality assurance guidelines as outlined in the site-specific QAPP. The QAPP guidelines typically require collection of equipment blank samples in order to determine the effectiveness of the decontamination procedure.

The decontamination method, solvent, frequency, location on site and the method of containment and disposal of decontamination wash solids and solutions are dependent on site logistics, site-specific chemistry, and nature of the contaminated media to be studied and the objectives of the study. Each topic must be considered and addressed during development of a decontamination strategy and should be outlined in the Quality Assurance Project Plan (QAPP).

#### 1.3.2 Solvent Selection

There are several factors which need to be considered when deciding upon a decontamination solvent. The solvent should not be an analyte of interest. The sampling equipment must be resistant to the solvent. The solvent must be evaporative or water soluble or preferably both. The applicable regulatory agency may have specific requirements regarding decontamination solvents. The QAPP should specify the type of solvent to be used for a particular project.

The analytical objectives of the study must also be considered when deciding upon a decontamination solvent. Pesticide-grade methanol is the solvent of choice for general organic analyses. It is relatively safe and effective. Hexane, acetone, and isopropanol are sometimes used as well. A 10% nitric acid in deionized water solution is the solvent of choice for general metals

analyses. Nitric acid can be used only on Teflon, plastics and glass. If used on metal equipment, nitric acid will eventually corrode the metal and lead to the introduction of metals to the collected samples. Dilute hydrochloric acid is usually preferred over nitric acid when cleaning metal sampling equipment.

Equipment decontamination should be performed a safe distance away from the sampling area so as not to interfere with sampling activities but close enough to the sampling area to maintain an efficient working environment. If heavy equipment such as drill rigs or backhoes are to be decontaminated, then a central decontamination station should be constructed with access to a power source and water supply.

#### 1.4 Health and Safety Considerations

Decontamination procedures may involve chemical exposure hazards associated with the type of contaminants encountered or solvents employed and may involve physical hazards associated with decontamination equipment. When decontamination is performed on equipment which has been in contact with hazardous materials or when the quality assurance objectives of the project require decontamination with chemical solvents, the measures necessary to protect personnel must be addressed in the project Health and Safety Plan (HASP). This plan must be approved by the project Health and Safety Officer before work commences, must be distributed to all personnel performing equipment decontamination, and must be adhered to as field activities are performed.

## 2.0 RESPONSIBILITIES

### 2.1 Sampling Technician

It is the responsibility of the sampling technician to be familiar with the decontamination procedures outlined within this SOP and with specific quality assurance, and health and safety requirements outlined within project-specific work plans (HASP, QAPP). The sampling technician is responsible for decontamination of field equipment and for proper documentation of decontamination activities. The sampling technician is also responsible for ensuring that decontamination procedures are followed by subcontractors when heavy equipment requires decontamination.



## 2.2 Field Project Manager

The field project manager is responsible for ensuring that the required decontamination procedures are followed at all times. The project manager is also responsible for ensuring that subcontractors construct and operate their decontamination facilities according to project specifications. The project manager is responsible for collection and control of IDW in accordance with project specifications.

## 3.0 REQUIRED MATERIALS

- Decontamination agents (per work plan requirements):
  - LIQUI-NOX, ALCONOX, or other phosphate-free biodegradable detergent,
  - Tap water,
  - Distilled/deionized water,
  - Nitric acid and/or hydrochloric acid,
  - Methanol and/or hexane, acetone, isopropanol.
- Health and Safety equipment
- Chemical-free paper towels
- Waste storage containers: drums, 5-gallon pails w/covers, plastic bags
- Cleaning containers: plastic buckets or tubs, galvanized steel pans, pump cleaning cylinder
- Cleaning brushes
- Pressure sprayers
- Squeeze bottles
- Plastic sheeting
- Aluminum foil
- *Field project notebook/pen*

## 4.0 METHODS

### 4.1 General Preparation

- 4.1.1 It should be assumed that all sampling equipment, even new items, are contaminated until the proper decontamination procedures have been performed on them or unless a certificate of analysis is available which demonstrates the items cleanliness.

Field equipment that is not frequently used should be wrapped in aluminum foil, shiny side out, and stored in a designated "clean" area. Small field equipment can also be stored in plastic bags to eliminate the potential for contamination. Field equipment should be inspected and decontaminated prior to use if the equipment appears contaminated and/or has been stored for long periods of time. Unless customized procedures are stated in the QAPP for decontamination of equipment, the standard procedures specified in this SOP shall be followed.

- 4.1.2 Establish the decontamination station within an area that is convenient to the sampling location. If single samples will be collected from multiple locations, then a centralized decontamination station, or a portable decontamination station should be established.

- 4.1.3 An investigation-derived waste (IDW) containment station should be established at this time also. The project-specific work plan should specify the requirements for IDW containment. In general, decontamination solutions are discarded as IDW between sampling locations. Solid waste is disposed of as it is generated.

### 4.2 Decontamination for Organic Analyses

- 4.2.1 This procedure applies to soil sampling and groundwater sampling equipment used in the collection of environmental samples submitted for organic constituents analysis. Examples of relevant items of equipment include split-spoons, trowels, scoops/spoons, bailers, and other small items. Submersible pump decontamination procedures are outlined in Section 4.4.

- 4.2.2 Decontamination is to be performed before sampling events and between sampling points.

- 4.2.3 After a sample has been collected, remove all gross contamination from the equipment or material by brushing and then rinsing with available tap water.

This initial step may be completed using a 5-gallon pail filled with tap water. Steam or a high-pressure water rinse may also be conducted to remove solids and/or other contamination.

- 4.2.4 Wash the equipment with a phosphate-free detergent and tap water solution. This solution should be kept in a 5-gallon pail with its own brush.
- 4.2.5 Rinse with tap water or distilled/deionized water until all detergent and other residue is washed away. This step can be performed over an empty bucket using a squeeze bottle or pressure sprayer.
- 4.2.6 Rinse with methanol or other appropriate solvent using a squeeze bottle or pressure sprayer. Rinsate should be collected in a waste bucket.
- 4.2.7 Rerinse with deionized water to remove any residual solvent. Rinsate should be collected in the solvent waste bucket.
- 4.2.8 Allow the equipment to air-dry in a clean area or blot with chemical-free paper towels before reuse. Wrap the equipment in tin foil and/or seal it in a plastic bag if it will not be reused for a while.
- 4.2.9 Dispose of soiled materials and spent solutions in the designated IDW disposal containers.

#### 4.3 Decontamination for Inorganic (Metals) Analyses

- 4.3.1 This procedure applies to soil sampling equipment used primarily in the collection of environmental samples submitted for inorganic constituents analysis. Examples of relevant items of equipment include split-spoons, trowels, scoops/spoons, bailers, and other small items.
- 4.3.2 For plastic and glass sampling equipment, follow the steps outlined in 4.2 above, however, use a 10% nitric acid solution (acid in water) in place of the solvent rinse in Section 4.2.6.
- 4.3.3 For metal sampling equipment, follow the steps outlined in 4.2 above, however, use a 10% hydrochloric acid solution (acid in water) in place of the solvent rinse in Section 4.2.6.

#### 4.4 Decontamination of Submersible Pumps

- 4.4.1** This procedure will be used to decontaminate submersible pumps before and between ground-water sample collection points. This procedure applies to both electric submersible and bladder pumps. This procedure also applies to discharge tubing if it will be reused between sampling points.
- 4.4.2** Prepare the decontamination area if pump decontamination will be conducted next to the sampling point. If decontamination will occur at another location, the pump and tubing may be removed from the well and placed into a clean trash bag for transport to the decontamination area. Pump decontamination is easier with the use of 3-foot tall pump cleaning cylinders (i.e., Nalgene cylinder) for the various cleaning solutions, although the standard bucket rinse equipment may be used.
- 4.4.3** Once the decontamination station is established, the pump should be removed from the well and the discharge tubing and power cord coiled by hand as the equipment is removed. If any of the equipment needs to be put down temporarily, place it on a plastic sheet (around well) or in a clean trash bag. If a disposable discharge line is used it should be removed and discarded at this time.
- 4.4.4** As a first step in the decontamination procedure, use a pressure sprayer with tap water to rinse the exterior of the pump, discharge line, and power cord as necessary. Collect the rinsate and handle as IDW.
- 4.4.5** Place the pump into a pump cleaning cylinder or bucket containing a detergent solution (detergent in tap water). Holding the tubing/power cord, pump solution through the pump system. A minimum of one gallon of detergent solution should be pumped through the system. Collect the rinsate and handle as IDW.
- 4.4.6** Place the pump into another cylinder/bucket containing a 10% solution of solvent (methanol, or other designated solvent) in distilled/deionized water. Pump until the detergent solution is removed. Collect the rinsate and handle as IDW.
- 4.4.7** Place the pump into another cylinder/bucket containing distilled/deionized water. Pump a minimum of 3 to 5 pump system volumes (pump and tubing) of water through the system. Collect the rinsate and handle as IDW.

- 4.4.8** Remove the pump from the cylinder/bucket and if the pump is reversible, place the pump in the reverse mode to discharge all removable water from the system. If the pump is not reversible the pump and discharge line should be drained by hand as much as possible. Collect the rinsate and handle as IDW.
- 4.4.9** Using a pressure sprayer with distilled/deionized water, rinse the exterior of the pump, discharge line, and power cord thoroughly, shake all excess water, then place the pump system into a clean trash bag for storage. If the pump system will not be used again right away, the pump itself should also be wrapped with aluminum foil before placing it into the bag.

#### **4.5 Decontamination of Large Equipment**

- 4.5.1** Consult the QAPP for instruction on the location of the decontamination station and the method of containment of the wash solutions. On large projects usually a temporary decontamination facility (decontamination pad) is required which may include a membrane-lined and bermed area large enough to drive heavy equipment (drill rig, backhoe) onto with enough space to spread other equipment and to contain overspray. Usually a small sump with pump is necessary to collect and contain rinsate. A water supply and power source is also necessary to run steam cleaning and/or pressure washing equipment.
- 4.5.2** Upon arrival and prior to leaving a sampling site, all heavy equipment such as drill rigs, trucks, and backhoes should be thoroughly cleaned and then the parts of the equipment which come in contact or in close proximity to sampling activity should be decontaminated. This can be accomplished in two ways, steam cleaning or high pressure water wash and manual scrubbing. Following this initial cleaning, only those parts of the equipment which come in close proximity to the sampling activities (i.e., auger stems, rods, backhoe bucket) must be decontaminated in between sampling events.

Occasionally, well construction materials such as well screen and riser pipe may require decontamination before the well materials are used. These materials may be washed in the decontamination pad, preferably on a raised surface above the pad (i.e., on sawhorses), with clean plastic draped over the work surfaces. Well materials usually do not require a multistep cleaning process as they generally arrive clean from the manufacturer. Usually, a thorough steam-cleaning of the interior/exterior of the well materials will be sufficient. The QAPP should provide specific guidance regarding decontamination of well materials.

## 5.0 QUALITY CONTROL

### 5.1 Field Blank Sample Collection

General guidelines for quality control check of field equipment decontamination usually require the collection of one field blank from the decontaminated equipment per day. The QAPP should specify the type and frequency of collection of each type of quality assurance sample.

Field blanks are generally made by pouring laboratory-supplied deionized water into, over, or through the freshly decontaminated sampling equipment and then transferring this water into a sample container. Field blanks should then be labeled as a sample and submitted to the laboratory to be analyzed for the same parameters as the associated sample. Field blank sample numbers, as well as collection method, time and location should be recorded in the field notebook.

## 6.0 DOCUMENTATION

Specific information regarding decontamination procedures should be documented in the project-specific field notebook. Documentation within the notebook should thoroughly describe the construction of each decontamination facility and the decontamination steps implemented in order to show compliance with the project work plan. Decontamination events should be logged when they occur with the following information documented:

- Date, time and location of each decontamination event
- Equipment decontaminated
- Method
- Solvents
- Noteable circumstances
- Identification of field blanks and decontamination rinsates
- Method of blank and rinsate collection
- Date, time and location of blank and rinsate collection
- Disposition of IDW

Repetitive decontamination of small items of equipment does not need to be logged each time the item is cleaned.

## 7.0 TRAINING/QUALIFICATIONS

All sampling technicians performing decontamination must be properly trained in the decontamination procedures employed, the project data quality objectives, health and safety

procedures and the project QA procedures. Specific training or orientation will be provided for each project to ensure that personnel understand the special circumstances and requirements of that project. Field personnel should be health and safety certified as specified by OSHA (29 CFR 1910.120(e)(3)(i)) to work on sites where hazardous materials may be present.

## 8.0 REFERENCES

Not applicable.

**SOP**

**Concrete Core Sampling**

---



**Concrete Core Sampling****Date:** 2003**Revision Number:****Author:****Discipline:** Geosciences**1.0 PURPOSE AND APPLICABILITY****1.1 Purpose and Applicability**

This standard operating procedure (SOP) describes the methods used for obtaining concrete core samples for physical and/or chemical analysis.

The purpose of this SOP is to provide a specific method and/or procedure to be used in the collection of concrete core samples which, if followed properly, will promote consistency in sampling and provide a basis for sample representativeness.

It should be noted that other specific state and/or federal agency standard operating procedures may be in existence in certain areas which may require deviation from this sampling procedure. The applicability of other agency operating procedures, which may differ from ENSR's SOP, needs to be determined prior to start of the sampling program. Deviations from this SOP to accommodate other regulatory requirements should be reviewed in advance of the field program, should be explained in the project work plan, and must be documented in the field project notebook when they occur.

**1.2 General Principles**

Concrete core sampling generally involves use of a diamond core to obtain representative concrete samples. A diamond tipped core barrel will be advanced through the concrete, to the desired depth and the material removed.

**1.3 Quality Assurance Planning Considerations**

Project personnel should follow specific quality assurance guidelines for sampling as outlined in the site-specific QAPP and/or Sampling Plan. Proper quality assurance requirements should be provided which will allow for collection of representative samples from representative sampling points. Quality assurance requirements typically suggest the collection of a sufficient quantity of field duplicate, field blank, and equipment blank samples.

#### 1.4 Health and Safety Considerations

Concrete core sampling may involve chemical exposure hazards associated with the type of contaminants present in the concrete, and physical hazards may be present due to the use of potentially heavy equipment. When concrete sampling is performed, adequate Health and Safety measures must be taken to protect sampling personnel. These measures must be addressed in the project Health and Safety Plan (HASP). This plan must be approved by the project Health and Safety Officer before work commences, must be distributed to all personnel performing sampling, and must be adhered to as field activities are performed.

### 2.0 RESPONSIBILITIES

#### 2.1 Sampling Personnel

It will be the responsibility of the sampling personnel to conduct concrete core sampling in a manner consistent with this SOP. The above individual will be responsible for the proper use and maintenance of all types of equipment used for obtaining concrete core samples, and the collection, labeling, handling and storage of all samples until further chain-of-custody procedures are undertaken.

#### 2.2 Sampling Coordinator

Large sampling programs may require additional support personnel such as a sampling coordinator. The sampling coordinator is responsible for providing management support such as maintaining an orderly sampling process, providing instructions to sampling personnel regarding sampling locations, and fulfilling sample documentation requirements, thereby allowing sampling personnel to collect samples in an efficient manner.

#### 2.3 Project Manager

It is the responsibility of the project manager to ensure that the sampling activity is properly staffed, planned, and executed.

### 3.0 REQUIRED MATERIALS

#### 3.1 Concrete Core Equipment

The concrete coring equipment will have a diamond or other similar tipped core barrel. The diameter of the barrel will vary depending on the volume of materials required for

analysis. The drive train for the equipment will either be a gasoline driven engine or an electric powered unit.

### 3.2 Collection Pan

A concrete core collection pan is often used as an intermediate sample container between removal of the sample from the concrete surface and final bottling of the sample. The collection pans should preferably be constructed of stainless steel. Additionally, single-use, disposable aluminum pans may be used for individual samples, though they can not be decontaminated sufficiently for re-use.

### 3.3 Supporting Materials

- Hammer
- Sample kit (i.e., bottles, labels, custody records, cooler, etc.)
- Sample logs/boring logs
- Decontamination materials
- Six-foot folding rule or tape measure for depth measurement
- Personal protective equipment (as required by the HASP)
- Field project notebook/pen

## 4.0 METHOD

### 4.1 General Procedures

Site-specific concrete characteristics such as density and reinforcement will generally dictate the preferred type of sampling equipment for use at a particular site. Similarly, other project-specific requirements such as sampling depth and requested type of analysis such as physical testing and/or chemical analysis will dictate the use of a preferred type of sampling equipment. Analytical testing requirements will indicate sample volume requirements that also will influence the selection of the appropriate type of sampling tool. The project sampling plan should define the specific requirements for collection of surface soil samples at a particular site. Should site-specific characteristics remain unidentified prior to start of the sampling program, sampling personnel should be equipped with a variety of sampling equipment to address the most likely sampling situations to be encountered.

As indicated, sample volume and sampling depth requirements should be defined in the sampling plan. This information should define the size of the hole which will be created during collection of the sample. For instance, if only a 500-ml sample will be required for analysis from a depth interval of 0 to 6 inches, an approximate 2 to 3-inch diameter hole

will be needed. The indicated types of sampling equipment will generally make a minimum diameter hole of approximately 3 inches, therefore, an excess volume of concrete may be generated during collection of a small volume sample. For samples requiring a large volume of soil, multiple holes and compositing may be necessary. Collection of the requisite volume to meet sample volume requirements without underestimating the sample volume is the overall objective and is a technique which improves with experience.

It should be noted that some sampling programs may require the use of a sampling grid for the purpose of obtaining a statistically representative number of samples. This SOP does not provide information relative to construction of a sampling grid. This information may be found in other documents.

#### 4.2 Equipment Decontamination

Regardless of the specific type of equipment used, each piece of equipment needs to be decontaminated prior to its initial use and following collection of each individual sample. Site-specific requirements for equipment decontamination should be outlined within the project sampling plan. Equipment decontamination procedures are specified within ENSR SOP 7600 - Decontamination of Equipment.

#### 4.3 Collection of Samples for Analysis

To limit the potential for loss of volatiles, the concrete sample must be obtained as quickly and as directly as possible. This generally means that if a VOA sample is to be collected as part of a multiple analyte sample, the VOA sample portion should be obtained first. The VOA sample should also be obtained from a discrete portion of the entire collected sample and not from a sample which has been composited or homogenized from the entire sample interval. In general, it is best to collect the VOA sample by transferring the sample directly from the interior of the sampling tool into the sample bottles.

The samples should be chipped from the interior of the core sample, in an area which has had minimal exposure to the frictional heat generated during the drill process. The chip samples will be removed and broken into a fine powder for shipment to the laboratory. The chip samples will be broken using decontaminated hammer in a stainless steel, or similar material, collection pan. The volatile fraction of the sample will be collected first. Additional sample chips will be collected and pulverized in the collection pan to make a homogenized sample.

#### 4.4 Standard Procedures

#### 4.4.1 Surface Preparation

At some sampling locations, the surface may require preparation in advance of sampling. Surface preparation can include removal of surface debris which blocks access to the actual surface. If sampling equipment is used for both removal of surface debris and for collection of the sample, the equipment should be decontaminated prior to sample collection to reduce the potential for sample interferences between the surface debris and the underlying media to be sampled.

Once each sample container is filled, the rim and threads of the sample container will be cleaned of gross materials by wiping with a paper towel, then capped and labeled. Do not submerge the sample containers in water to clean them. Once labeled the sample containers should be placed into a cooler for protection. Sample chain-of-custody and other documentation requirements should be completed at this time.

The sampling tool and other sampling equipment should be decontaminated prior to reuse. All investigation-derived waste should be properly contained before leaving the area.

The sample hole should be backfilled to eliminate any surface hazard. The project sampling plan may indicate the requirements for backfilling of the sample hole.

## 5.0 QUALITY CONTROL

Quality control requirements for sample collection are dependent on project-specific sampling objectives. The Quality Assurance Project Plan (QAPP) will provide requirements for sample preservation and holding times, container types, sample packaging and shipment, as well as requirements for the collection of various quality assurance samples such as trip blanks, field blanks, equipment blanks, and field duplicate samples.

## 6.0 DOCUMENTATION

Various forms are required to ensure that adequate documentation is made of the sample collection activities. These forms include:

- Field log books
- Sample collection records
- Chain-of-custody forms

- Shipping labels

The field book will be maintained as an overall log of all samples collected throughout the study. Sample collection records are generated for each sample collected and include specific information about the sample (Figure 1). Chain-of-custody forms are transmitted with the samples to the laboratory for sample tracking purposes. Shipping labels are required if sample coolers are to be transported to the laboratory by a third party (courier service). Originals and/or copies of these documents will be retained in the appropriate project files.

## **7.0 TRAINING/QUALIFICATIONS**

Concrete core sampling is a relatively simple procedure requiring minimal training and a relatively small amount of equipment. It is, however, recommended that initial attempts be supervised by more experienced personnel. Sampling personnel should be health and safety certified as specified by OSHA (29 CFR 1910.120(e)(3)(i)) to work on sites where hazardous materials may be present.

## **8.0 REFERENCES**

Not applicable.

**FIGURE 1 Concrete Core Sample Log**



**SURFACE SOIL SAMPLE LOG**

Project Number: \_\_\_\_\_ Project Location: \_\_\_\_\_

Sample Point No.: \_\_\_\_\_

Date: \_\_\_\_\_

Time: \_\_\_\_\_

Sample Point Description/Designation: \_\_\_\_\_

---



---



---

**SAMPLE COLLECTION**

Equipment Used: \_\_\_\_\_

No. of Samples Collected: \_\_\_\_\_

Container Size: \_\_\_\_\_

Sample Number	Depth	Type of Material	Analyses Requested

**Comments:**

---



---



---

Lab Designation \_\_\_\_\_

Shipping ID Number: \_\_\_\_\_

Collector's Name \_\_\_\_\_

**SOP**

**Sediment Sampling**

---



**Sediment Sampling:  
Catch Basins and Floor Drains****Date:** 2003**Revision Number:****Author:****Discipline:** Geosciences**1.0 PURPOSE AND APPLICABILITY****1.1 Purpose and Applicability**

This standard operating procedure (SOP) describes the methods used for obtaining sediment samples for physical and/or chemical analysis.

The purpose of this SOP is to provide a specific method and/or procedure to be used in the collection of sediment samples which, if followed properly, will promote consistency in sampling and provide a basis for sample representativeness.

It should be noted that other specific state and/or federal agency standard operating procedures may be in existence in certain areas which may require deviation from this sampling procedure. The applicability of other agency operating procedures, which may differ from ENSR's SOP, needs to be determined prior to start of the sampling program. Deviations from this SOP to accommodate other regulatory requirements should be reviewed in advance of the field program, should be explained in the project work plan, and must be documented in the field project notebook when they occur.

**1.2 General Principles**

Sediment sampling generally involves use of a scoop to obtain representative sediment samples.

**1.3 Quality Assurance Planning Considerations**

Project personnel should follow specific quality assurance guidelines for sampling as outlined in the site-specific QAPP and/or Sampling Plan. Proper quality assurance requirements should be provided which will allow for collection of representative samples from representative sampling points. Quality assurance requirements typically suggest the collection of a sufficient quantity of field duplicate, field blank, and equipment blank samples.

**1.4 Health and Safety Considerations**

Sediment sampling may involve chemical exposure hazards associated with the type of contaminants present in surface soil. When sediment sampling is performed, adequate Health and Safety measures must be taken to protect sampling personnel. These measures must be addressed in the project Health and Safety Plan (HASP). This plan must be approved by the project Health and Safety Officer before work commences, must be distributed to all personnel performing sampling, and must be adhered to as field activities are performed.

## **2.0 RESPONSIBILITIES**

### **2.1 Sampling Personnel**

It will be the responsibility of the sampling personnel to conduct sediment sampling in a manner consistent with this SOP. The above individual will be responsible for the proper use and maintenance of all types of equipment used for obtaining sediment samples, and the collection, labeling, handling and storage of all samples until further chain-of-custody procedures are undertaken.

### **2.2 Sampling Coordinator**

Large sampling programs may require additional support personnel such as a sampling coordinator. The sampling coordinator is responsible for providing management support such as maintaining an orderly sampling process, providing instructions to sampling personnel regarding sampling locations, and fulfilling sample documentation requirements, thereby allowing sampling personnel to collect samples in an efficient manner.

### **2.3 Project Manager**

It is the responsibility of the project manager to ensure that the sampling activity is properly staffed, planned, and executed.

## **3.0 REQUIRED MATERIALS**

- Clean polyethylene sheeting;
- Clean gloves (the composition of the gloves depends on the material being sampled -- refer to the project-specific QAPP and HASP);
- Scoop sampler
- Calibrated photoionization detector (PID) or flame ionization detector (FID);
- Chemical-free towelettes;
- Teaspoon
- Sample kit (bottles, labels, ice, custody records and tape, cooler
- HASP-required PPE

**4.0 METHOD**

- For each sample location, collect sediment samples using the following procedure:
- Create a clean workspace using clean polyethylene sheeting.
- Put on clean gloves immediately before sampling.
- Remove the scoop from protective packaging.
- Use scoop to collect sample of sediment
- Fill bottle ware from the scoop, using stainless steel teaspoon as needed.

Supporting Materials

- Sample logs
- Decontamination materials
- Six-foot folding rule or tape measure for depth measurement
- Personal protective equipment (as required by the HASP)
- Field project notebook/pen

**5.0 EQUIPMENT DECONTAMINATION**

Regardless of the specific type of equipment used, each piece of equipment needs to be decontaminated prior to its initial use and following collection of each individual sample. Site-specific requirements for equipment decontamination should be outlined within the project sampling plan. Equipment decontamination procedures are specified within ENSR SOP 7600 - Decontamination of Equipment.

**6.0 COLLECTION OF SAMPLES FOR ANALYSIS**

To limit the potential for loss of volatiles, the concrete sample must be obtained as quickly and as directly as possible. This generally means that if a VOA sample is to be collected as part of a multiple analyte sample, the VOA sample portion should be obtained first. The VOA sample should also be obtained from a discrete portion of the entire collected sample and not from a sample which has been composited or homogenized from the entire sample interval. In general, it is best to collect the VOA sample by transferring the sample directly from the interior of the sampling tool into the sample bottles.

## **6.1 Standard Procedures**

### **6.1.1 Surface Preparation**

At some sampling locations, the surface may require preparation in advance of sampling. Surface preparation can include removal of surface debris which blocks access to the actual surface. If sampling equipment is used for both removal of surface debris and for collection of the sample, the equipment should be decontaminated prior to sample collection to reduce the potential for sample interferences between the surface debris and the underlying media to be sampled.

Once each sample container is filled, the rim and threads of the sample container will be cleaned of gross materials by wiping with a paper towel, then capped and labeled. Do not submerge the sample containers in water to clean them. Once labeled the sample containers should be placed into a cooler for protection. Sample chain-of-custody and other documentation requirements should be completed at this time.

The sampling tool and other sampling equipment should be decontaminated prior to reuse. All investigation-derived waste should be properly contained before leaving the area.

The sample hole should be backfilled to eliminate any surface hazard. The project sampling plan may indicate the requirements for backfilling of the sample hole.

## **7.0 QUALITY CONTROL**

Quality control requirements for sample collection are dependent on project-specific sampling objectives. The Quality Assurance Project Plan (QAPP) will provide requirements for sample preservation and holding times, container types, sample packaging and shipment, as well as requirements for the collection of various quality assurance samples such as trip blanks, field blanks, equipment blanks, and field duplicate samples.

## **8.0 DOCUMENTATION**

Various forms are required to ensure that adequate documentation is made of the sample collection activities. These forms include:

- Field log books
- Sample collection records
- Chain-of-custody forms
- Shipping labels

The field book will be maintained as an overall log of all samples collected throughout the study. Sample collection records are generated for each sample collected and include specific information about the sample (Figure 1). Chain-of-custody forms are transmitted with the samples to the laboratory for sample tracking purposes. Shipping labels are required if sample coolers are to be transported to the laboratory by a third party (courier service). Originals and/or copies of these documents will be retained in the appropriate project files.

## **9.0 TRAINING/QUALIFICATIONS**

Sediment sampling is a relatively simple procedure requiring minimal training and a relatively small amount of equipment. It is, however, recommended that initial attempts be supervised by more experienced personnel. Sampling personnel should be health and safety certified as specified by OSHA (29 CFR 1910.120(e)(3)(i)) to work on sites where hazardous materials may be present.

## **10.0 REFERENCES**

Not applicable.

**FIGURE 1 Sediment Sample Log**



**SEDIMENT SAMPLE LOG**

Project Number: \_\_\_\_\_

Project Location: \_\_\_\_\_

Sample Point No.: \_\_\_\_\_

Date: \_\_\_\_\_

Time: \_\_\_\_\_

Sample Point Description/Designation: \_\_\_\_\_

**SAMPLE COLLECTION**

Equipment Used: \_\_\_\_\_

No. of Samples Collected: \_\_\_\_\_

Container Size: \_\_\_\_\_

Sample Number	Depth	Type of Material	Analyses Requested

Comments: \_\_\_\_\_

Lab Designation \_\_\_\_\_

Shipping ID Number: \_\_\_\_\_

Collector's Name \_\_\_\_\_

**APPENDIX E**

**Method Detection Limits for Laboratory Analyses**

---

**STL Buffalo**  
**PQL/MDL**

Parameter	Protocol	Method	Matrix	UM	STL PQL	MDL
Aluminum - Total	SW8463	6010	S	MG/KG	10	2.2
Antimony - Total	SW8463	6010	S	MG/KG	15	3.65
Arsenic - Total	SW8463	6010	S	MG/KG	2	0.64
Barium - Total	SW8463	6010	S	MG/KG	0.5	0.13
Beryllium - Total	SW8463	6010	S	MG/KG	0.2	0.04
Cadmium - Total	SW8463	6010	S	MG/KG	0.2	0.063
Calcium - Total	SW8463	6010	S	MG/KG	10	4.4
Chromium - Total	SW8463	6010	S	MG/KG	0.5	0.139
Cobalt - Total	SW8463	6010	S	MG/KG	0.5	0.107
Copper - Total	SW8463	6010	S	MG/KG	1	0.238
Iron - Total	SW8463	6010	S	MG/KG	10	3.1
Lead - Total	SW8463	6010	S	MG/KG	1	0.307
Magnesium - Total	SW8463	6010	S	MG/KG	20	0.9
Manganese - Total	SW8463	6010	S	MG/KG	0.2	0.053
Nickel - Total	SW8463	6010	S	MG/KG	0.5	0.12
Potassium - Total	SW8463	6010	S	MG/KG	30	8.4
Selenium - Total	SW8463	6010	S	MG/KG	4	1.1
Silver - Total	SW8463	6010	S	MG/KG	0.5	0.145
Sodium - Total	SW8463	6010	S	MG/KG	140	41.7
Thallium - Total	SW8463	6010	S	MG/KG	6	2.468
Vanadium - Total	SW8463	6010	S	MG/KG	0.5	0.095
Zinc - Total	SW8463	6010	S	MG/KG	2	0.64
Aluminum - Total	SW8463	6010	W	MG/L	0.2	0.0237
Antimony - Total	SW8463	6010	W	MG/L	0.02	0.00585
Arsenic - Total	SW8463	6010	W	MG/L	0.007	0.0046
Arsenic - Total	SW8463	6010	W	MG/L	0.007	0.0046
Barium - Total	SW8463	6010	W	MG/L	0.001	0.00074
Barium - Total	SW8463	6010	W	MG/L	0.001	0.00074
Beryllium - Total	SW8463	6010	W	MG/L	0.005	0.00029
Cadmium - Total	SW8463	6010	W	MG/L	0.001	0.00032
Cadmium - Total	SW8463	6010	W	MG/L	0.001	0.00032
Calcium - Total	SW8463	6010	W	MG/L	0.5	0.0155
Chromium - Total	SW8463	6010	W	MG/L	0.002	0.00134
Chromium - Total	SW8463	6010	W	MG/L	0.002	0.00134
Cobalt - Total	SW8463	6010	W	MG/L	0.005	0.0014
Copper - Total	SW8463	6010	W	MG/L	0.005	0.00166
Iron - Total	SW8463	6010	W	MG/L	0.05	0.0334
Lead - Total	SW8463	6010	W	MG/L	0.01	0.0038
Lead - Total	SW8463	6010	W	MG/L	0.01	0.0038
Magnesium - Total	SW8463	6010	W	MG/L	0.2	0.0182
Manganese - Total	SW8463	6010	W	MG/L	0.003	0.00024
Nickel - Total	SW8463	6010	W	MG/L	0.01	0.0024
Potassium - Total	SW8463	6010	W	MG/L	0.5	0.0561
Selenium - Total	SW8463	6010	W	MG/L	0.01	0.0062
Silver - Total	SW8463	6010	W	MG/L	0.003	0.00185
Silver - Total	SW8463	6010	W	MG/L	0.003	0.00185
Sodium - Total	SW8463	6010	W	MG/L	1	0.349
Vanadium - Total	SW8463	6010	W	MG/L	0.005	0.00144
Zinc - Total	SW8463	6010	W	MG/L	0.02	0.00224
Selenium - Total	SW8463	6020	W	UG/L	1	0.442
Thallium - Total	SW8463	6020	W	UG/L	0.2	0.083



STL Buffalo  
PQL/MDL

Parameter	Protocol	Method	Matrix	UM	STL PQL	MDL
Mercury - Total	SW8463	7470	W	MG/L	0.0002	0.00017
Mercury - Total	SW8463	7471	S	MG/KG	0.02	0.0136
4,4'-DDD	SW8463	8081	S	UG/KG	1.67	0.2395
4,4'-DDE	SW8463	8081	S	UG/KG	1.67	0.22158
4,4'-DDT	SW8463	8081	S	UG/KG	1.67	0.15306
Aldrin	SW8463	8081	S	UG/KG	1.67	0.12101
alpha-BHC	SW8463	8081	S	UG/KG	1.67	0.15181
beta-BHC	SW8463	8081	S	UG/KG	1.67	0.97747
Chlordane	SW8463	8081	S	UG/KG	16.67	1.5605
delta-BHC	SW8463	8081	S	UG/KG	1.67	0.19895
Dieldrin	SW8463	8081	S	UG/KG	1.67	0.14301
Endosulfan I	SW8463	8081	S	UG/KG	1.67	0.20681
Endosulfan II	SW8463	8081	S	UG/KG	1.67	0.13326
Endosulfan Sulfate	SW8463	8081	S	UG/KG	1.67	0.28978
Endrin	SW8463	8081	S	UG/KG	1.67	1.13588
Endrin aldehyde	SW8463	8081	S	UG/KG	1.67	0.47396
gamma-BHC (Lindane)	SW8463	8081	S	UG/KG	1.67	0.19895
Heptachlor	SW8463	8081	S	UG/KG	1.67	0.53368
Heptachlor epoxide	SW8463	8081	S	UG/KG	1.67	0.86181
Methoxychlor	SW8463	8081	S	UG/KG	1.67	1.68748
Toxaphene	SW8463	8081	S	UG/KG	33	9.41737
4,4'-DDD	SW8463	8081	W	UG/L	0.05	0.0132
4,4'-DDE	SW8463	8081	W	UG/L	0.05	0.00723
4,4'-DDT	SW8463	8081	W	UG/L	0.05	0.00723
Aldrin	SW8463	8081	W	UG/L	0.05	0.02012
alpha-BHC	SW8463	8081	W	UG/L	0.05	0.00566
beta-BHC	SW8463	8081	W	UG/L	0.05	0.00754
Chlordane	SW8463	8081	W	UG/L	0.5	0.077
delta-BHC	SW8463	8081	W	UG/L	0.05	0.04872
Dieldrin	SW8463	8081	W	UG/L	0.05	0.00534
Endosulfan I	SW8463	8081	W	UG/L	0.05	0.00974
Endosulfan II	SW8463	8081	W	UG/L	0.05	0.00597
Endosulfan Sulfate	SW8463	8081	W	UG/L	0.05	0.01069
Endrin	SW8463	8081	W	UG/L	0.05	0.00691
Endrin aldehyde	SW8463	8081	W	UG/L	0.05	0.01194
gamma-BHC (Lindane)	SW8463	8081	W	UG/L	0.05	0.00503
Heptachlor	SW8463	8081	W	UG/L	0.05	0.0154
Heptachlor epoxide	SW8463	8081	W	UG/L	0.05	0.00754
Methoxychlor	SW8463	8081	W	UG/L	0.05	0.04494
Toxaphene	SW8463	8081	W	UG/L	1	0.19707
Aroclor 1016	SW8463	8082	S	UG/KG	16.66666	3.26118
Aroclor 1221	SW8463	8082	S	UG/KG	16.66666	6.95672
Aroclor 1232	SW8463	8082	S	UG/KG	16.66666	3.12131
Aroclor 1242	SW8463	8082	S	UG/KG	16.66666	2.90256
Aroclor 1248	SW8463	8082	S	UG/KG	16.66666	3.98752
Aroclor 1254	SW8463	8082	S	UG/KG	16.66666	8.66085
Aroclor 1260	SW8463	8082	S	UG/KG	16.66666	6.57138
Aroclor 1016	SW8463	8082	W	UG/L	0.5	0.176
Aroclor 1221	SW8463	8082	W	UG/L	0.5	0.1764
Aroclor 1232	SW8463	8082	W	UG/L	0.5	0.3647
Aroclor 1242	SW8463	8082	W	UG/L	0.5	0.31

# STL Buffalo PQL/MDL

Parameter	Protocol	Method	Matrix	UM	STL PQL	MDL
Aroclor 1248	SW8463	8082	W	UG/L	0.5	0.1055
Aroclor 1254	SW8463	8082	W	UG/L	0.5	0.0786
Aroclor 1260	SW8463	8082	W	UG/L	0.5	0.25
1,1,1-Trichloroethane	SW8463	8260	S	UG/KG	5	1.59916
1,1,2,2-Tetrachloroethane	SW8463	8260	S	UG/KG	5	1.56741
1,1,2-Trichloro-1,2,2-trifluoroethane	SW8463	8260	S	UG/KG	5	0.32844
1,1,2-Trichloroethane	SW8463	8260	S	UG/KG	5	1.49293
1,1-Dichloroethane	SW8463	8260	S	UG/KG	5	1.55358
1,1-Dichloroethene	SW8463	8260	S	UG/KG	5	1.68936
1,2,4-Trichlorobenzene	SW8463	8260	S	UG/KG	5	1.343
1,2-Dibromo-3-chloropropane	SW8463	8260	S	UG/KG	5	1.65228
1,2-Dibromoethane	SW8463	8260	S	UG/KG	5	1.75348
1,2-Dichlorobenzene	SW8463	8260	S	UG/KG	5	1.24997
1,2-Dichloroethane	SW8463	8260	S	UG/KG	5	1.23457
1,2-Dichloropropane	SW8463	8260	S	UG/KG	5	1.36186
1,3-Dichlorobenzene	SW8463	8260	S	UG/KG	5	1.2352
1,4-Dichlorobenzene	SW8463	8260	S	UG/KG	5	1.33295
2-Butanone	SW8463	8260	S	UG/KG	25	7.22261
2-Hexanone	SW8463	8260	S	UG/KG	25	7.41465
4-Methyl-2-pentanone	SW8463	8260	S	UG/KG	25	4.06044
Acetone	SW8463	8260	S	UG/KG	25	11.73282
Benzene	SW8463	8260	S	UG/KG	5	1.57841
Bromodichloromethane	SW8463	8260	S	UG/KG	5	1.28989
Bromoform	SW8463	8260	S	UG/KG	5	0.55663
Bromomethane	SW8463	8260	S	UG/KG	5	2.41477
Carbon Disulfide	SW8463	8260	S	UG/KG	5	2.3013
Carbon Tetrachloride	SW8463	8260	S	UG/KG	5	1.44515
Chlorobenzene	SW8463	8260	S	UG/KG	5	1.51775
Chloroethane	SW8463	8260	S	UG/KG	5	2.67029
Chloroform	SW8463	8260	S	UG/KG	5	1.56773
Chloromethane	SW8463	8260	S	UG/KG	5	2.46065
cis-1,2-Dichloroethene	SW8463	8260	S	UG/KG	5	1.77674
cis-1,3-Dichloropropene	SW8463	8260	S	UG/KG	5	1.33609
Cyclohexane	SW8463	8260	S	UG/KG	5	5
Dibromochloromethane	SW8463	8260	S	UG/KG	5	1.15505
Dichlorodifluoromethane	SW8463	8260	S	UG/KG	5	1.91126
Ethylbenzene	SW8463	8260	S	UG/KG	5	1.50424
Isopropylbenzene	SW8463	8260	S	UG/KG	5	2.00869
Methyl acetate	SW8463	8260	S	UG/KG	5	3.74
Methyl tert butyl ether	SW8463	8260	S	UG/KG	5	1.07553
Methylcyclohexane	SW8463	8260	S	UG/KG	5	2.55
Methylene chloride	SW8463	8260	S	UG/KG	5	4.48569
Styrene	SW8463	8260	S	UG/KG	5	1.32509
Tetrachloroethene	SW8463	8260	S	UG/KG	5	1.71985
Toluene	SW8463	8260	S	UG/KG	5	1.46935
Total Xylenes	SW8463	8260	S	UG/KG	15	2.26
trans-1,2-Dichloroethene	SW8463	8260	S	UG/KG	5	1.89083
trans-1,3-Dichloropropene	SW8463	8260	S	UG/KG	5	1.59822
Trichloroethene	SW8463	8260	S	UG/KG	5	1.65102
Trichlorofluoromethane	SW8463	8260	S	UG/KG	5	2.69732
Vinyl acetate	SW8463	8260	S	UG/KG	25	5.38899

**STL Buffalo  
PQL/MDL**

Parameter	Protocol	Method	Matrix	UM	STL PQL	MDL
Vinyl chloride	SW8463	8260	S	UG/KG	10	2.55809
1,1,1-Trichloroethane	SW8463	8260	W	UG/L	1	0.3398
1,1,2,2-Tetrachloroethane	SW8463	8260	W	UG/L	1	0.4158
1,1,2-Trichloro-1,2,2-trifluoroethane	SW8463	8260	W	UG/L	1	0.177
1,1,2-Trichloroethane	SW8463	8260	W	UG/L	1	0.2866
1,1-Dichloroethane	SW8463	8260	W	UG/L	1	0.518
1,1-Dichloroethene	SW8463	8260	W	UG/L	1	0.4121
1,2,4-Trichlorobenzene	SW8463	8260	W	UG/L	1	0.3341
1,2-Dibromo-3-chloropropane	SW8463	8260	W	UG/L	1	0.76601
1,2-Dibromoethane	SW8463	8260	W	UG/L	1	0.3074
1,2-Dichlorobenzene	SW8463	8260	W	UG/L	1	0.3143
1,2-Dichloroethane	SW8463	8260	W	UG/L	1	0.3259
1,2-Dichloropropane	SW8463	8260	W	UG/L	1	0.3838
1,3-Dichlorobenzene	SW8463	8260	W	UG/L	1	0.28001
1,4-Dichlorobenzene	SW8463	8260	W	UG/L	1	0.3269
2-Butanone	SW8463	8260	W	UG/L	5	2.74204
2-Hexanone	SW8463	8260	W	UG/L	5	1.2578
4-Methyl-2-pentanone	SW8463	8260	W	UG/L	5	1.1183
Acetone	SW8463	8260	W	UG/L	5	3.3671
Benzene	SW8463	8260	W	UG/L	1	0.4007
Bromodichloromethane	SW8463	8260	W	UG/L	1	0.2452
Bromoform	SW8463	8260	W	UG/L	1	0.2706
Bromomethane	SW8463	8260	W	UG/L	1	0.5117
Carbon Disulfide	SW8463	8260	W	UG/L	1	0.5475
Carbon Tetrachloride	SW8463	8260	W	UG/L	1	0.4843
Chlorobenzene	SW8463	8260	W	UG/L	1	0.3879
Chloroethane	SW8463	8260	W	UG/L	1	0.4466
Chloroform	SW8463	8260	W	UG/L	1	0.3825
Chloromethane	SW8463	8260	W	UG/L	1	0.4837
cis-1,2-Dichloroethene	SW8463	8260	W	UG/L	1	0.2756
cis-1,3-Dichloropropene	SW8463	8260	W	UG/L	1	0.3039
Cyclohexane	SW8463	8260	W	UG/L	1	0.11126
Dibromochloromethane	SW8463	8260	W	UG/L	1	0.2851
Dichlorodifluoromethane	SW8463	8260	W	UG/L	1	0.6896
Ethylbenzene	SW8463	8260	W	UG/L	1	0.3756
Isopropylbenzene	SW8463	8260	W	UG/L	1	0.40482
Methyl acetate	SW8463	8260	W	UG/L	1	0.14804
Methyl tert butyl ether	SW8463	8260	W	UG/L	1	0.6119
Methylcyclohexane	SW8463	8260	W	UG/L	1	0.09775
Methylene chloride	SW8463	8260	W	UG/L	1	0.7738
Styrene	SW8463	8260	W	UG/L	1	0.3555
Tetrachloroethene	SW8463	8260	W	UG/L	1	0.3926
Toluene	SW8463	8260	W	UG/L	1	0.3385
Total Xylenes	SW8463	8260	W	UG/L	3	0.582
trans-1,2-Dichloroethene	SW8463	8260	W	UG/L	1	0.5874
trans-1,3-Dichloropropene	SW8463	8260	W	UG/L	1	0.2615
Trichloroethene	SW8463	8260	W	UG/L	1	0.3108
Trichlorofluoromethane	SW8463	8260	W	UG/L	1	0.5145
Vinyl acetate	SW8463	8260	W	UG/L	5	1.7796
Vinyl chloride	SW8463	8260	W	UG/L	1	0.4033
2,2'-Oxybis(1-Chloropropane)	SW8463	8270	S	UG/KG	330	213.72

**STL Buffalo**  
**PQL/MDL**

Parameter	Protocol	Method	Matrix	UM	STL PQL	MDL
2,4,5-Trichlorophenol	SW8463	8270	S	UG/KG	800	179.78
2,4,6-Trichlorophenol	SW8463	8270	S	UG/KG	330	204.92
2,4-Dichlorophenol	SW8463	8270	S	UG/KG	330	195.81
2,4-Dimethylphenol	SW8463	8270	S	UG/KG	330	197.38
2,4-Dinitrophenol	SW8463	8270	S	UG/KG	1600	91.15
2,4-Dinitrotoluene	SW8463	8270	S	UG/KG	330	137.35
2,6-Dinitrotoluene	SW8463	8270	S	UG/KG	330	172.24
2-Chloronaphthalene	SW8463	8270	S	UG/KG	330	204.61
2-Chlorophenol	SW8463	8270	S	UG/KG	330	197.07
2-Methylnaphthalene	SW8463	8270	S	UG/KG	330	203.67
2-Methylphenol	SW8463	8270	S	UG/KG	330	200.84
2-Nitroaniline	SW8463	8270	S	UG/KG	1600	199.27
2-Nitrophenol	SW8463	8270	S	UG/KG	330	180.09
3,3'-Dichlorobenzidine	SW8463	8270	S	UG/KG	660	176.32
3-Nitroaniline	SW8463	8270	S	UG/KG	1600	171.92
4,6-Dinitro-2-methylphenol	SW8463	8270	S	UG/KG	16500	551.8
4-Bromophenyl phenyl ether	SW8463	8270	S	UG/KG	330	174.12
4-Chloro-3-methylphenol	SW8463	8270	S	UG/KG	330	191.09
4-Chloroaniline	SW8463	8270	S	UG/KG	330	187.32
4-Chlorophenyl phenyl ether	SW8463	8270	S	UG/KG	330	165.32
4-Methylphenol	SW8463	8270	S	UG/KG	330	190.78
4-Nitroaniline	SW8463	8270	S	UG/KG	1600	177.27
4-Nitrophenol	SW8463	8270	S	UG/KG	1600	118.49
Acenaphthene	SW8463	8270	S	UG/KG	330	210.58
Acenaphthylene	SW8463	8270	S	UG/KG	330	197.07
Acetophenone	SW8463	8270	S	UG/KG	330	78.36033
Anthracene	SW8463	8270	S	UG/KG	330	183.55
Atrazine	SW8463	8270	S	UG/KG	330	93.59948
Benzaldehyde	SW8463	8270	S	UG/KG	330	31.12419
Benzo(a)anthracene	SW8463	8270	S	UG/KG	330	97.12
Benzo(a)pyrene	SW8463	8270	S	UG/KG	330	148.04
Benzo(b)fluoranthene	SW8463	8270	S	UG/KG	330	228.5
Benzo(ghi)perylene	SW8463	8270	S	UG/KG	330	137.98
Benzo(k)fluoranthene	SW8463	8270	S	UG/KG	330	209.32
Benzoic acid	SW8463	8270	S	UG/KG	1600	671.03
Benzyl alcohol	SW8463	8270	S	UG/KG	330	189.84
Biphenyl	SW8463	8270	S	UG/KG	330	61.1895
Bis(2-chloroethoxy) methane	SW8463	8270	S	UG/KG	330	214.67
Bis(2-chloroethyl) ether	SW8463	8270	S	UG/KG	330	196.44
Bis(2-ethylhexyl) phthalate	SW8463	8270	S	UG/KG	330	263.07
Butyl benzyl phthalate	SW8463	8270	S	UG/KG	330	151.49
Caprolactam	SW8463	8270	S	UG/KG	330	49.99916
Chrysene	SW8463	8270	S	UG/KG	330	127.92
Dibenzo(a,h)anthracene	SW8463	8270	S	UG/KG	330	124.78
Dibenzofuran	SW8463	8270	S	UG/KG	330	209.32
Diethyl phthalate	SW8463	8270	S	UG/KG	330	137.66
Dimethyl phthalate	SW8463	8270	S	UG/KG	330	179.47
Di-n-butyl phthalate	SW8463	8270	S	UG/KG	330	194.24
Di-n-octyl phthalate	SW8463	8270	S	UG/KG	330	203.98
Fluoranthene	SW8463	8270	S	UG/KG	330	153.38
Fluorene	SW8463	8270	S	UG/KG	330	193.92

STL Buffalo  
PQL/MDL

Parameter	Protocol	Method	Matrix	UM	STL PQL	MDL
Hexachlorobenzene	SW8463	8270	S	UG/KG	330	147.72
Hexachlorobutadiene	SW8463	8270	S	UG/KG	330	203.35
Hexachlorocyclopentadiene	SW8463	8270	S	UG/KG	330	182.29
Hexachloroethane	SW8463	8270	S	UG/KG	330	208.07
Indeno(1,2,3-cd)pyrene	SW8463	8270	S	UG/KG	330	123.83
Isophorone	SW8463	8270	S	UG/KG	330	249.24
Naphthalene	SW8463	8270	S	UG/KG	330	194.87
Nitrobenzene	SW8463	8270	S	UG/KG	330	220.64
N-Nitroso-Di-n-propylamine	SW8463	8270	S	UG/KG	330	175.69
N-nitrosodiphenylamine	SW8463	8270	S	UG/KG	330	166.58
Pentachlorophenol	SW8463	8270	S	UG/KG	1600	131.38
Phenanthrene	SW8463	8270	S	UG/KG	330	154.95
Phenol	SW8463	8270	S	UG/KG	330	222.52
Pyrene	SW8463	8270	S	UG/KG	330	139.86
2,2'-Oxybis(1-Chloropropane)	SW8463	8270	W	UG/L	10	4.75096
2,4,5-Trichlorophenol	SW8463	8270	W	UG/L	10	5.84357
2,4,6-Trichlorophenol	SW8463	8270	W	UG/L	10	5.67846
2,4-Dichlorophenol	SW8463	8270	W	UG/L	10	4.59067
2,4-Dimethylphenol	SW8463	8270	W	UG/L	10	4.21602
2,4-Dinitrophenol	SW8463	8270	W	UG/L	50	33.7951
2,4-Dinitrotoluene	SW8463	8270	W	UG/L	10	4.64944
2,6-Dinitrotoluene	SW8463	8270	W	UG/L	10	3.8662
2-Chloronaphthalene	SW8463	8270	W	UG/L	10	5.60523
2-Chlorophenol	SW8463	8270	W	UG/L	10	3.52896
2-Methylnaphthalene	SW8463	8270	W	UG/L	10	4.6743
2-Methylphenol	SW8463	8270	W	UG/L	10	3.40261
2-Nitroaniline	SW8463	8270	W	UG/L	50	6.12382
2-Nitrophenol	SW8463	8270	W	UG/L	10	3.68768
3,3'-Dichlorobenzidine	SW8463	8270	W	UG/L	20	10.09563
3-Nitroaniline	SW8463	8270	W	UG/L	50	5.63226
4,6-Dinitro-2-methylphenol	SW8463	8270	W	UG/L	50	18.28
4-Bromophenyl phenyl ether	SW8463	8270	W	UG/L	10	4.12424
4-Chloro-3-methylphenol	SW8463	8270	W	UG/L	10	4.51523
4-Chloroaniline	SW8463	8270	W	UG/L	10	5.18312
4-Chlorophenyl phenyl ether	SW8463	8270	W	UG/L	10	4.45646
4-Methylphenol	SW8463	8270	W	UG/L	10	3.44913
4-Nitroaniline	SW8463	8270	W	UG/L	50	7.74309
4-Nitrophenol	SW8463	8270	W	UG/L	50	10.49008
Acenaphthene	SW8463	8270	W	UG/L	10	5.25132
Acenaphthylene	SW8463	8270	W	UG/L	10	5.72026
Acetophenone	SW8463	8270	W	UG/L	10	1.2
Anthracene	SW8463	8270	W	UG/L	10	5.47259
Atrazine	SW8463	8270	W	UG/L	10	10
Benzaldehyde	SW8463	8270	W	UG/L	50	20.5
Benzo(a)anthracene	SW8463	8270	W	UG/L	10	7.47594
Benzo(a)pyrene	SW8463	8270	W	UG/L	10	5.26798
Benzo(b)fluoranthene	SW8463	8270	W	UG/L	10	4.90497
Benzo(ghi)perylene	SW8463	8270	W	UG/L	10	4.93011
Benzo(k)fluoranthene	SW8463	8270	W	UG/L	10	6.92371
Benzoic acid	SW8463	8270	W	UG/L	50	6.7
Benzyl alcohol	SW8463	8270	W	UG/L	20	3.16814

**STL Buffalo  
PQL/MDL**

Parameter	Protocol	Method	Matrix	UM	STL PQL	MDL
Biphenyl	SW8463	8270	W	UG/L	10	2.435
Bis(2-chloroethoxy) methane	SW8463	8270	W	UG/L	10	4.39831
Bis(2-chloroethyl) ether	SW8463	8270	W	UG/L	10	4.16227
Bis(2-ethylhexyl) phthalate	SW8463	8270	W	UG/L	10	6.99223
Butyl benzyl phthalate	SW8463	8270	W	UG/L	10	6.42932
Caprolactam	SW8463	8270	W	UG/L	10	4.59
Chrysene	SW8463	8270	W	UG/L	10	5.89595
Dibenzo(a,h)anthracene	SW8463	8270	W	UG/L	10	4.83205
Dibenzofuran	SW8463	8270	W	UG/L	10	5.18721
Diethyl phthalate	SW8463	8270	W	UG/L	10	4.89239
Dimethyl phthalate	SW8463	8270	W	UG/L	10	4.97003
Di-n-butyl phthalate	SW8463	8270	W	UG/L	10	5.11586
Di-n-octyl phthalate	SW8463	8270	W	UG/L	10	7.92822
Fluoranthene	SW8463	8270	W	UG/L	10	5.77181
Fluorene	SW8463	8270	W	UG/L	10	5.63131
Hexachlorobenzene	SW8463	8270	W	UG/L	10	4.16542
Hexachlorobutadiene	SW8463	8270	W	UG/L	10	3.97149
Hexachlorocyclopentadiene...	SW8463	8270	W	UG/L	10	2.86767
Hexachloroethane	SW8463	8270	W	UG/L	10	4.15253
Indeno(1,2,3-cd)pyrene	SW8463	8270	W	UG/L	10	4.71921
Isophorone	SW8463	8270	W	UG/L	10	4.61644
Naphthalene	SW8463	8270	W	UG/L	10	4.22199
Nitrobenzene	SW8463	8270	W	UG/L	10	4.03121
N-Nitroso-DI-n-propylamine	SW8463	8270	W	UG/L	10	4.33671
N-nitrosodiphenylamine	SW8463	8270	W	UG/L	10	4.60135
Pentachlorophenol	SW8463	8270	W	UG/L	50	16.74653
Phenanthrene	SW8463	8270	W	UG/L	10	5.34907
Phenol	SW8463	8270	W	UG/L	10	4.49638
Pyrene	SW8463	8270	W	UG/L	10	6.3938



AK, Anchorage  
(907) 561-5700

AK, Fairbanks  
(907) 452-5700

AL, Birmingham  
(205) 980-0054

AL, Florence  
(256) 767-1210

CA, Alameda  
(510) 748-6700

CA, Camarillo  
(805) 388-3775

CA, Sacramento  
(916) 362-7100

CA, Santa Ana  
(949) 756-2667

CO, Ft. Collins  
(970) 493-8878

Ft. Collins Tox Lab  
(970) 416-0916

CT, Stamford  
(203) 323-6620

CT, Willington  
(860) 429-5323

FL, Jupiter  
(561) 743-6757

FL, St. Petersburg  
(727) 898-9591

FL, Tallahassee  
(850) 385-5006

GA, Norcross  
(770) 381-1836

GA, Savannah  
(912) 898-0015

IL, Chicago  
(630) 836-1700

MA, Air Laboratory  
(978) 772-2345

MA, Sagamore Beach  
(508) 888-3900

MA, Westford  
(978) 589-3000

MA, Woods Hole  
(508) 457-7900

MD, Columbia  
(410) 884-9280

ME, Portland  
(207) 773-9501

MI, Detroit  
(734) 458-9900

MN, Minneapolis  
(952) 924-0117

NC, Charlotte  
(704) 529-1755

NC, Raleigh  
(919) 872-6600

NH, Gilford  
(603) 524-8866

NJ, Piscataway  
(732) 457-0500

NY, Albany  
(518) 453-6444

NY, Rochester  
(585) 381-2210

NY, Syracuse  
(315) 432-0506

OH, Cincinnati  
(513) 772-7800

PA, Langhorne  
(215) 757-4900

PA, Pittsburgh  
(412) 261-2910

SC, Columbia  
(803) 216-0003

TX, Austin  
(512) 336-1002

TX, Dallas  
(972) 509-2250

TX, Houston  
(713) 520-9900

TX, San Antonio  
(210) 499-1385

WA, Redmond  
(425) 881-7700

WI, Green Bay  
(920) 884-1093

WI, Milwaukee  
(262) 523-2040

**Headquarters  
MA, Westford  
(978) 589-3000**

Azerbaijan

Bolivia

Brazil

Canada

China

England

Germany

India

Ireland

Italy

Malaysia

Mexico

Philippines

Scotland

Turkey

Venezuela

**[www.ensr.com](http://www.ensr.com)**