

report.hw 336006.2004-02-19, MWI_Groundwater_Evaluation, pdf

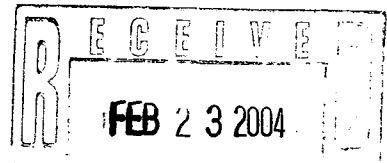
**MW-1 GROUNDWATER
EVALUATION**

**HARRIMAN SITE, HARRIMAN, NEW
YORK**

19 February 2004



Infrastructure, buildings, environment, communications



ARCADIS

MW-1 Groundwater Evaluation

Harriman Site
Harriman, New York

Prepared for:
Maybrook and Harriman Environmental
Trust

Prepared by:
ARCADIS G&M, Inc.
1200 MacArthur Boulevard
Mahwah
New Jersey 07430
Tel 201 236 2233
Fax 201 236 5110

Our Ref.:
NJ000389.0009.00039

Date:
19 February 2004

This document is intended only for the use of the individual or entity for which it was prepared and may contain information that is privileged, confidential, and exempt from disclosure under applicable law. Any dissemination, distribution, or copying of this document is strictly prohibited.

Table of Contents

1.0	Introduction	1
2.0	Objectives	1
3.0	Background	1
4.0	Vertical Profile Borings	2
5.0	Monitoring Well Installation	3
6.0	Groundwater Sampling	3
7.0	Analytical Results	4
7.1	Volatile Organic Compounds	4
7.2	Semi-Volatile Organic Compounds	4
7.3	Ammonia	4
7.4	Mercury	5
8.0	Conclusions and Recommendations	5

Tables

- 1 Summary of Field Parameters, Harriman Site, Harriman, New York.
- 2 Summary of Analytical Results, Harriman Site, Harriman, New York.

Figures

- 1 Site Location.
- 2 MW-1 Historical Benzene Concentrations.
- 3 Geological Section and Monitoring Wells.

ARCADIS

**MW-1 Groundwater
Evaluation
Harriman Site,
Harriman, New York**

Table of Contents

Appendices

- A Sample/Core Logs.
- B Monitoring Well Construction Logs.
- C Groundwater Sampling Logs.

1.0 Introduction

ARCADIS G&M, Inc. has been retained by the Maybrook and Harriman Environmental Trust to perform the Groundwater Evaluation at MW-1. The scope of work is based upon the New York State Department of Environmental Conservation's (NYSDEC) conditional approval, dated November 11, 2003, of the submitted work plan (ARCADIS, September 2003). The conditional approval requested that the wells remain for potential future sampling along with the addition of mercury analysis (total and dissolved) by USEPA Method 1631. The scope of work has been completed and the results of this evaluation are summarized in this report.

2.0 Objectives

The objective of this evaluation is to determine whether the benzene concentrations found in groundwater at MW-1 are contiguous with the groundwater plume at the site. In order to determine whether a connection exists, vertical profile borings were installed to define the stratigraphy, monitoring wells were installed in the aquitard and overburden aquifer, and groundwater samples were collected to evaluate the groundwater quality between the site and MW-1.

3.0 Background

MW-1 is located adjacent to the West Branch of the Ramapo River opposite the plant (see figure 1). MW-1 was installed as a monitoring well in 1988 and was later converted into an extraction well, as part of interim remedial measure (IRM) pump and treat system, in September 1990. The IRM system consists of MW-1 pumping at a rate of approximately 4 gallons per minute (gpm), and RW-1/R-3 pumping at a combined flow rate of approximately 30 gpm. The extracted groundwater is treated prior to discharge to the SPDES lagoon, which ultimately discharges to the Ramapo River.

Historically, the groundwater quality at MW-1 has exhibited variable concentrations of benzene above the Standards, Criteria, Guidance (SCG) value of 5 micrograms per liter (ug/L). Figure 2 shows the groundwater benzene concentrations throughout the time period from 1988 to present day. While benzene has been detected in MW-1, no other site constituents of concern such as the volatile organic compounds (toluene, ethylbenzene, xylene, and chlorobenzene) and the semi-volatile organic compounds (pyridine, alpha-picoline, and 2-amino-pyridine) have been detected.

The groundwater pump and treat system had reached asymptotic concentrations of benzene ranging from 100 to 300 ug/L. To improve the performance of the system,

ARCADIS received NYSDEC approval to install a three point biosparge system in the area of MW-1 in October 2002. The performance of the biosparge system had a marginal effect on the benzene concentrations.

ARCADIS made a request to temporarily terminate the pumping of MW-1 based on the hydraulic information collected during the Erosion Evaluation performed in June 2002. The evaluation indicated that while MW-1 was only pumping at 4 gpm, water level recovery data indicated that 8 to 10 feet of draw down was recorded in water levels. MW-28, installed near MW-1, showed very little change in water levels while MW-1 was pumping. These data suggested that the capture zone of MW-1 is very small and localized to approximately a 10 to 15 foot radius in the vicinity of the well.

In February 2003, NYSDEC provided approval to temporarily terminate groundwater pumping while continuing to biosparge. This was done to determine if the remediation results could be improved by allowing the groundwater to return to its natural hydraulic velocity and gradient, thereby increasing the contact time with the oxygen being provided by the biosparge system to maximize degradation. This change resulted in the lowest range of benzene concentrations detected in MW-1 (11 to 65 ug/L). Groundwater pumping was resumed in July 2003 and the benzene concentrations increased to greater than 100 ug/L.

In August 2002, ARCADIS also completed and submitted to the NYSDEC, the site groundwater model. The groundwater model demonstrated that the overburden aquifer groundwater plume is contained on-site and shrinking with time. The estimated time period from full remediation is approximately 11 years. The groundwater model also demonstrated that the pumping of RW-1 at an increased flow rate of approximately 25 gpm would provide the hydraulic capture for the impacts near MW-33 and MW-20.

4.0 Vertical Profile Borings

Vertical profile borings were advanced to define the lithology between MW-1 and the site. A licensed driller, Kendrick Enterprises LLC, advanced four vertical profile borings (SB-1 through SB-4) with an ARCADIS geologist providing oversight. Continuous 2-foot split-spoon samples were collected to log the stratigraphic information to define the fill, aquitard, and aquifer layers. The stratigraphic information was used to develop cross-section C-C' (see Figure 3). This information would be used to install the monitoring wells in the aquitard and aquifer and prevent bridging of the two layers. SB-1 was advanced closest to MW-1 to determine the lithology in the area. SB-2, SB-3, and SB-4 were advanced in locations closer to the

plant and subsequently converted to monitoring wells MW-35S, MW-36S, and MW-37S, respectively. Sample core logs are provided in Appendix A.

5.0 Monitoring Well Installation

Based on the vertical profile information, three clusters of monitoring wells were installed between MW-1 and MW-20S. Each cluster consisted of 2 monitoring wells, one well screened in the aquitard and one well screened in overburden aquifer. Monitoring wells MW-35AQ and MW-35S was installed approximately 130 feet upgradient from MW-1. Monitoring wells MW-36AQ and MW-36S was installed approximately 230 feet upgradient from MW-1, and monitoring wells MW-37AQ and MW-37S was installed approximately 340 feet upgradient from MW-1. The locations of the monitoring wells are shown on Figure 3.

The monitoring wells were constructed of 2-inch diameter polyvinyl chloride (PVC) riser and 10-slot screen. Well construction logs are provided in Appendix B. Each well was developed by the driller upon construction completion. The monitoring wells were then surveyed by a licensed surveyor to establish horizontal and vertical control.

6.0 Groundwater Sampling

On December 11, 2004, groundwater samples were collected from monitoring wells MW-35S, MW-35AQ, MW-36S, MW-36AQ, MW-37S, and MW-37AQ. The monitoring wells were purged and sampled in accordance with the "Ground Water Sampling Procedure, Low Stress (Low Flow) Purging and Sampling" (USEPA Region II 1998). Monitoring wells were purged using a bladder pump equipped with disposable tubing. Field parameters (temperature, pH, specific conductivity, dissolved oxygen, and oxidation-reduction potential) were monitored and recorded every five minutes during purging. When the field parameters stabilized, groundwater samples were collected directly from the tubing. Wells were sampled for volatile organic compounds (VOC), semi-volatile organic compounds (SVOC), ammonia, and mercury (total and dissolved) in accordance with the work plan. Field parameters are summarized in Table 1 and the groundwater sampling forms are provided in Appendix C.

Groundwater Samples were submitted to Severn Trent Laboratories, Inc. (STL) of Shelton, Connecticut, a certified laboratory, for laboratory analysis of the following parameters; benzene, toluene, ethylbenzene, xylene, chlorobenzene, pyridine, alpha-picoline, 2-amino-pyridine, and ammonia. Mercury samples were collected and sent to

Brooks Rand Laboratory, located on Seattle, Washington for mercury analysis (total and dissolved) using EPA Method 1631.

7.0 Analytical Results

The analytical results of the groundwater evaluation at MW-1 are summarized below.

7.1 Volatile Organic Compounds

The analytical results for the site constituents of concern (COCs) volatile organic compounds (benzene, toluene, chlorobenzene, ethylbenzene, and xylene) indicates that concentrations above SCGs were only detected in monitoring well cluster MW-37, nearest to Ardenhouse Road (see Figure 1). MW-37AQ had detectable concentrations of benzene (39 ug/L) and chlorobenzene (11 ug/L) while MW-37S had detectable concentrations of benzene at 50 ug/L. The results of MW-36 AQ and MW-36S, downgradient from the MW-37 well cluster indicated non-detectable and no exceedances of VOCs (benzene was detected at an estimated value of 5J in MW-36AQ). The results of the closest well cluster to MW-1, MW-35AQ and MW-35S, indicated non-detectable concentrations of VOCs. Table 2 provides a summary of the analytical results. It should be noted that groundwater samples collected from PZ-3 (located between the MW-35 and MW-36 well clusters), has always had non-detectable result.

7.2 Semi-Volatile Organic Compounds

The results of the analysis for the site COCs semi-volatile organic compounds (pyridine, alpha-picoline, and 2-aminopyridine) indicate that non-detectable concentrations were found in each of the six monitoring well sampled. These results are consistent with the historically non-detectable results for semi-volatile organic compounds at MW-1. The results are summarized in Table 2.

7.3 Ammonia

The results of the ammonia analysis indicates that ammonia was detected at concentrations ranging from 79 mg/L to 8 mg/L. Ammonia concentrations are generally in a declining trend towards MW-1.

7.4 Mercury

The analytical results for mercury indicate that concentrations are below the SCG for groundwater of 2 ug/L. Total mercury concentrations ranged from 0.008 ug/L to 0.933 ug/L. Dissolved mercury concentrations were much lower ranging from 0.003 ug/L to 0.082 ug/L.

8.0 Conclusions and Recommendations

Based on the results of this evaluation, it is evident that the benzene impact at MW-1 is localized and not associated with the groundwater plume at the site. The analytical results from the three new monitoring well clusters (MW-35, MW-36, and MW-37) demonstrated that no VOCs, including benzene, were detected in the well clusters closest (MW-35 and MW-36) to MW-1. This is also support by the fact that the semi-volatile compounds (pyridine, alpha-picoline, and 2-aminopyridine) that are present in the groundwater plume on site are not detected in any of the new well clusters. Ammonia concentrations appear to decrease in the direction of MW-1. Total mercury concentrations are well below the SCG of 2 ug/L while dissolved mercury concentrations are generally lower.

The concentration of benzene (50 ug/L) identified in monitoring well MW-37S is within the hydraulic capture zone of RW-1/R-3 and should be hydraulically contained. The groundwater model for the site (ARCADIS, August 2002) clearly demonstrates this.

Handwritten note:
} If RW-3 Down
WELL RW-1
CAPTURE
WATER MW-37S

In reviewing the historic benzene concentration trends at MW-1, it is clear that the concentration has reached an asymptote above 100 ug/L. The field parameter data collected during this evaluation indicates that the subsurface groundwater environment is in anaerobic condition with dissolved oxygen concentrations less than 1 mg/L and the oxidation/reduction potential (REDOX) in the range of -100 to -200 millivolt (mV). Based on these factors, a different remediation technique is required in an attempt to reach the SCG of 5 ug/L. ARCADIS proposes the following alternative to reduce benzene concentrations at MW-1:

Increase the air-flow from the three biosparge points near MW-1 from the current 1 cubic feet per minute (cfm) per point to 3-5 cfm per point to convert the subsurface environment to more aerobic conditions, thereby increasing the degradation rate of benzene. Additional biosparge points can be installed to keep the air flow rate at 1 cfm per point as an alternative to increasing the air flow at the existing points. In conjunction with the total increase air flow, the groundwater pumping rate would be

ARCADIS

MW-1 Groundwater
Evaluation
Harriman Site,
Harriman, New York

reduced (anticipate decreasing over time) to achieve the optimum conditions for air and groundwater contact to expedite the remediation on MW-1. Once a declining concentration trend can be demonstrated in two consecutive quarters (6 months) and concentrations at below 20 ug/L, the pumping at MW-1 would be terminated permanently.



TABLES



ARCADIS

Table 1. Summary of Field Parameters, MW-1 Groundwater Evaluation
Harriman Site, Harriman, New York.

Monitoring Well ID	pH (SI Units)	DO (mg/L)	REDOX (MV)
MW-35AQ	6.7	0.17	-149
MW-35S	7.2	0.08	-203
MW-36AQ	7.1	0.12	-201
MW-36S	7.2	0.11	-216
MW-37AQ	7.1	0.13	-232
MW-37S	7.2	0.18	-225

ARCADIS

Table 2. Summary of Analytical Results, MW-1 Groundwater Evaluation, Harriman Site, Harriman, New York.

Constituents	SCG (ug/L)	Monitoring Well ID Elevations (MSL) Sample Collection Date	MW-35AQ 525.92 12/11/2003	MW-35S 525.91 12/11/2003	MW-36AQ 526.44 12/11/2003	MW-36S 526.44 12/11/2003	MW-37AQ 526.06 12/11/2003	MW-37S 526.06 12/11/2003
<u>VOCs (ug/L)</u>								
Benzene	5		ND	ND	5J	ND	39	50
Toluene	5		ND	ND	ND	ND	ND	ND
Chlorobenzene	5		ND	ND	2J	1J	11	ND
Ethylbenzene	5		ND	ND	ND	ND	ND	ND
Xylenes (total)	5		ND	ND	ND	ND	ND	ND
<u>SVOCs (ug/L)</u>								
Pyridine	50		ND	ND	ND	ND	ND	ND
alpha-picoline	50		ND	ND	ND	ND	ND	ND
2-aminopyridine	50		ND	ND	ND	ND	ND	ND
Ammonia (mg/L)			8.1	24	36	16	79	79
<u>Mercury (1631)</u>								
Total	2		0.167	0.0477	0.456	0.0196	0.933	0.00845
Dissolved			0.0328	0.0157	0.0821	0.0222	0.00905	0.00262

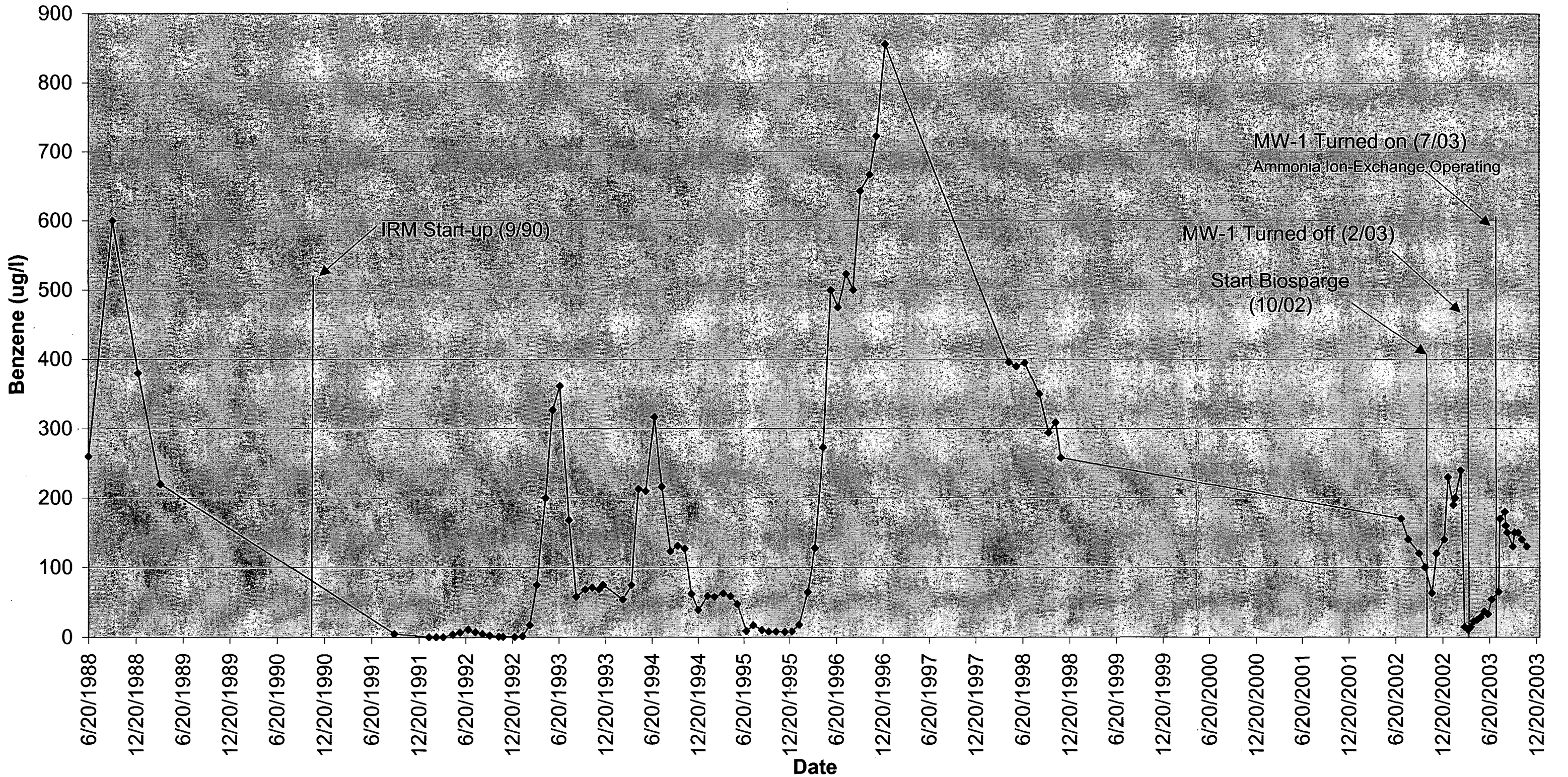
AQ Aquitard Monitoring Wells
 S Overburden Aquifer Monitoring Wells
 ND Not detected above MDL
 J Estimated Value
 ug/L Micrograms per Liter
 mg/L Milligrams per Liter
 SCG Standards, Criteria, & Guidance
 MSL Mean Sea Level



FIGURES

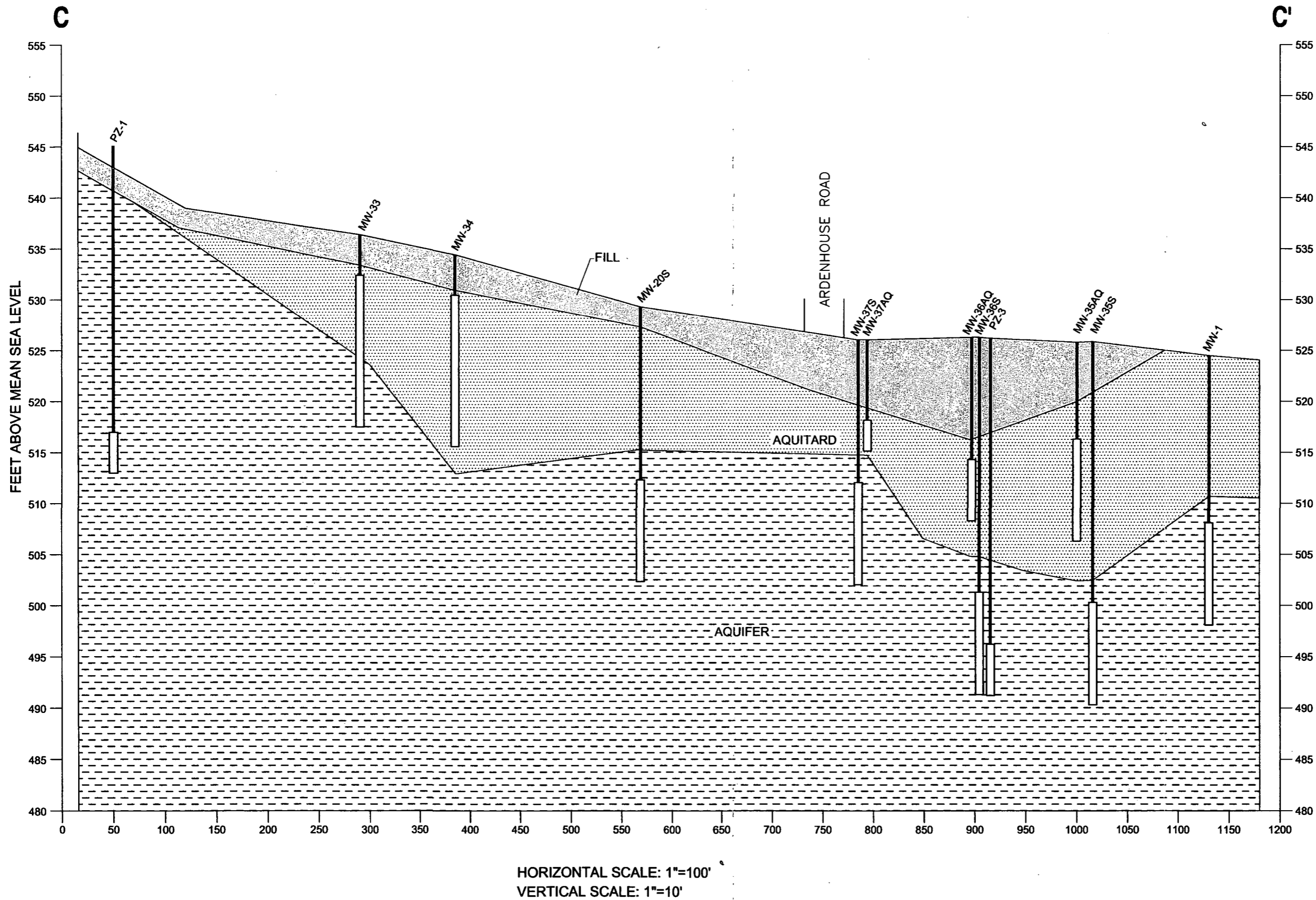


Figure 2: MW-1 Influent Data, Harriman Site, Harriman, New York



Date/Time : Fri, 13 Feb 2004 - 11:12am
 Path/Name : G:\Drafting\Trust\Fig1-2-SECTION AND KEY PLAN.dwg - Layout Tab : SECTION

Acad Version : R16.0
 User Name : pjmccle2
 Copyright © 2003



HORIZONTAL SCALE: 1"=100'
 VERTICAL SCALE: 1"=10'

REV. ISSUED DATE DESCRIPTION	KEYPLAN	<p>1200 MacArthur Boulevard Newark, NJ 07430 Tel: 201-238-2233 Fax: 201-238-5110 www.arcadis-us.com</p>	PROJECT TITLE HARRIMAN SITE HARRIMAN, NEW YORK	PROJECT MANAGER T. ENG	DEPARTMENT MANAGER T. ENG	LEAD DESIGN PROF.	CHECKED E. WRIGHT
				SHEET TITLE GEOLOGICAL SECTION AND MONITORING WELLS		TASK/PHASE NUMBER 00039	DRAWN BY LMC
				PROJECT NUMBER NJ000389.0009		DRAWING NUMBER 3	



ARCADIS

Appendix A

Sample/Core Logs

Sample/Core Log

Boring/Wel B-1 Project/No. NJ000389.0009.00039 Page 1 of 1

Site _____ Drilling _____ Drilling _____
 Location Harriman Site Started 11/19/2003 Completed 11/19/2003

Total Depth Drilled 25 Feet Hole Diameter 4" inches Type of Sample/
 Coring Device Split Spoon

Length and Diameter of Coring Device 4" X 2' Sampling Interval cont. feet

Land-Surface Elev. _____ feet Surveyed Estimated Datum _____

Drilling Fluid Used _____ Drilling Method Mud Rotary

Drilling Contractor Kendrick Enterprises LLC Driller Tom Helper Danny

Prepared By E. Wright Hammer Weight 300 lbs. Hammer Drop 30 ins.

Sample/Core Depth (feet below land surface) Core Recovery (feet) Time/Hydraulic Pressure or Blows per 6 Inches

From	To	Core Recovery (feet)	Time/Hydraulic Pressure or Blows per 6 Inches	Sample/Core Description
0	2	1.4	2-2-4-2	0-0.2' Topsoil, organics, black.
				0.2-1.4' CLAY; little Silt; Varves present, grey to brown.
2	4	1.6	4-5-5-8	0-0.3' CLAY; little Silt; Grey to brown.
				0.3-1.6' SILT; some Clay; grey to brown.
4	6	1.4	6-5-6-5	SILTY CLAY; Compact, medium moisture, grey to brown.
6	8	2.0	3-4-3-4	CLAY; little Silt; Saturated, grey.
8	10	1.5	3-3-3-4	CLAY; little Silt; Finely stratified, saturated, grey.
10	12	2.0	1-2-2-1	0-1.0' CLAY; little Silt; Saturated, grey.
				1.0-1.5' SILT; Saturated, grey.
				1.5-2.0' CLAY; little Silt; Saturated, grey.
12	14	1.7	8-10-5-7	0-1.5' SILT; Homogenous, saturated, grey.
				1.5-1.7' SAND, Fine; some Silt; Saturated, grey.
14	16	1.4	18-37-15-12	GRAVELY SAND, Fine to Medium; Angular to Sub-angular, saturated, grey.
16	17			Boulder/Cobble.
17	19	1.1	12-7-8-8	SAND, Fine to Medium; and Gravel, Fine to Medium; Angular, saturated, grey.
19	21	0.8	10-31-24-24	SANDY GRAVEL, Fine to Coarse; Angular, saturated, grey.
21	23	0.8	18-24-18-20	SANDY GRAVEL; Same as above.
23	25	0.5	36-30-20-19	0-0.3' Same as above.
				0.3-0.5' SILTY SAND, Fine to Medium; little Gravel, Fine; Saturated, grey.

Sample/Core Log

Boring/Wel B-2 Project/No. NJ000389.0009.00039 Page 1 of 2

Site Harriman Site Drilling Started 11/19/2003 Drilling Completed 11/20/2003

Total Depth Drilled 35 Feet Hole Diameter 4" inches Type of Sample/ Coring Device Split Spoon

Length and Diameter of Coring Device 4" X 2' Sampling Interval cont. feet

Land-Surface Elev. _____ feet Surveyed Estimated Datum _____

Drilling Fluid Used _____ Drilling Method Mud Rotary

Drilling Contractor Kendrick Enterprises LLC Driller Tom Helper Danny

Prepared By E. Wright Hammer Weight 300 lbs. Hammer Drop 30 ins.

From	To	Sample/Core Depth (feet below land surface)	Core Recovery (feet)	Time/Hydraulic Pressure or Blows per 6 Inches	Sample/Core Description
------	----	---	----------------------	---	-------------------------

0	2	0.9	15-5-3-2	0-0.3' Asphalt
				0.3-0.8' GRAVELY SAND, Fine to Coarse; little Silt; Angular, saturated, perched watertable, brown.
				0.8-0.9' CLAY; little Silt; Compact, brown to black. At 0.85'-0.9', Clay layer, white.
2	4	0.3	2-2-2-1	SANDY GRAVEL, Fine to Coarse; little Silt; Angular, saturated, brown.
4	6		2-1-1-0	No Recovery. No B-2, S-3 sample taken.
6	8	1.0	1-1-1-1	CLAY; Saturated, grey- dark grey.
8	10		1-0-1-0	No Recovery. No B-2, S-5 sample taken.
10	12	1.3	5-6-7-6	CLAY; little Silt; Saturated, compact, light grey.
12	14	0.2	7-8-8-8	SILT; some Gravel, Fine to Medium; Angular to Sub-angular, saturated, grey.
14	16	1.5	4-6-5-6	SILT; and Sand, Fine; Grey to green.
16	18	1.7	6-6-6-6	SILT; and Sand, Fine; Grey to green.
18	20	1.5	4-5-4-3	Same as above.
20	22	2.0	4-3-3-2	SILT; and Sand, Fine to Coarse; Gravel, Fine at the tip; Grey to green.
22	24	1.5	8-6-37-33	0-1.0' SILT; and Sand, Fine.
				1.0-1.5' SAND; and Gravel.
24	26	1.0	12-10-11-13	GRAVELY SAND, Fine to Coarse; some Silt.

Sample/Core Log

Boring/Wel B-3 Project/No. NJ000389.0009.00039 Page 1 of 2

Site Harriman Site Drilling Started 11/19/2003 Drilling Completed 11/19/2003

Total Depth Drilled 34 Feet Hole Diameter 4" inches Type of Sample/
Coring Device Split Spoon

Length and Diameter of Coring Device 4" X 2' Sampling Interval cont. feet

Land-Surface Elev. _____ feet Surveyed Estimated Datum _____

Drilling Fluid Used _____ Drilling Method Mud Rotary

Drilling Contractor Kendrick Enterprises LLC Driller Tom Helper Danny

Prepared By E. Wright Hammer Weight 300 lbs. Hammer Drop 30 ins.

Sample/Core Depth (feet below land surface)	Core Recovery (feet)	Time/Hydraulic Pressure or Blows per 6 Inches
--	----------------------------	--

From	To	Core Recovery (feet)	Time/Hydraulic Pressure or Blows per 6 Inches	Sample/Core Description
0	2	0.8	13-8-3-2	0-0.3' Asphalt
				0.3-0.8' SILTY CLAY; some Sand, Fine to Medium; little Gravel, Fine; Angular, medium moisture, brown.
2	4	0.6	1/2.0'	SILTY SAND, Fine to Medium; little Clay; little Gravel, Fine to Medium; Angular, high moisture, brown.
4	6		1-0-1-1	No Recovery. No B-3, S-3 sample taken.
6	8	1.0	1-2-1-2	SANDY SILT, Fine to Medium; some Gravel, Fine to Medium; Sub-angular, saturated, brown. Piece of plastic found at the base, black.
8	10	0.9	1-2-7-11	SANDY SILT, Fine to Coarse; some Clay; little Gravel, Fine to Medium; Angular, saturated, brown from 0'-0.8', grey from 0.8'-0.9'.
10	12	1.4	9-10-10-10	SILT; saturated, grey.
12	14	1.5	4-6-5-6	Same as above.
14	16	1.1	3-4-3-3	Same as above.
16	18	1.5	1-2-1-1	Same as above.
				0.2-1.0' SANDY SILT, Fine; Saturated, grey.
18	20	1.0	2-7-3-3	SILT; saturated, grey.
20	22	1.3	5-6-8-9	0-1.0' Same as above.
				1.0-1.3' GRAVELY SAND, Fine to Coarse; Angular, saturated, grey.
22	24	0.5	16-10-9-8	GRAVELY SAND, Fine to Coarse; Rounded to Angular, grey.

Sample/Core Log

Boring/Wel B-4 Project/No. NJ000389.0009.00039 Page 1 of 1

Site Location Harriman Site Drilling Started 11/24/2003 Drilling Completed 11/24/2003

Total Depth Drilled 24 Feet Hole Diameter 4" inches Type of Sample/
Coring Device Split Spoon

Length and Diameter of Coring Device 4" X 2' Sampling Interval cont. feet

Land-Surface Elev. _____ feet Surveyed Estimated Datum _____

Drilling Fluid Used _____ Drilling Method Mud Rotary

Drilling Contractor Kendrick Enterprises LLC Driller Tom Helper Danny

Prepared By E. Wright Hammer Weight 300 lbs. Hammer Drop 30 ins.

Sample/Core Depth (feet below land surface)	Core Recovery (feet)	Time/Hydraulic Pressure or Blows per 6 Inches	Sample/Core Description
---	----------------------	---	-------------------------

From	To	Core Recovery (feet)	Time/Hydraulic Pressure or Blows per 6 Inches	Sample/Core Description
0	2	0.7	42-5-4-3	0-0.3' Asphalt
				0.3-0.7' SANDY SILT; little Gravel, Fine to Medium; little Clay; Angular, brown.
2	4	0.2	2-2-1-1	Same as above, high moisture.
4	6	0.4	1-0-0-1	Same as above, saturated.
6	8	0.3	2-2-3-3	0-0.2' Same as above.
				0.2-0.3' CLAY; little Silt; Saturated, grey.
8	10	1.3	8-8-9-6	SILTY CLAY; Saturated, slight odor, grey.
10	12	1.4	7-5-12-16	0-0.9' SILT; little Clay; Grey.
				0.9-1.4' SANDY GRAVEL, Fine to Coarse; little Silt; Angular, slight odor, grey-brown.
12	14	0.7	21-20-25-25	Same as above, slight odor, grey-brown.
14	16	1.2	18-15-17-20	SANDY GRAVEL, Fine to Coarse; little Silt; Angular, brown.
16	18	1.3	10-11-12-18	Same as above.
18	20	1.1	17-22-31-40	GRAVELY SAND, Fine to Coarse; trace Silt; Angular, brown.
20	22	1.0	17-22-28-28	SANDY SILT, Very Fine to Medium; little Gravel, Fine to Coarse; Angular, grey-brown.
22	24	1.3	21-21-31-21	SILTY SAND, Very Fine to Coarse; trace Gravel, Fine to Medium; Angular, grey.



APPENDIX B



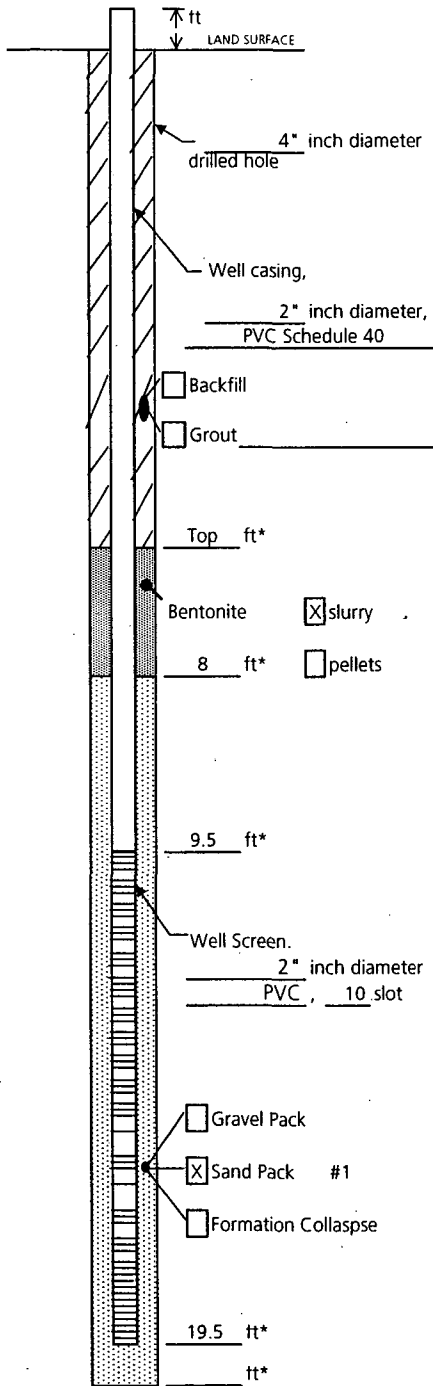
ARCADIS

Appendix B

Monitoring Well
Construction Logs

Well Construction Log

(Unconsolidated)



Measuring Point is
Top of Well Casing
Unless Otherwise Noted.

* Depth Below Land Surface

Project NJ000389.0009.00039 Well MW-35AQ

Town/City Harriman

County Orange State NY

Permit No. _____

Land-Surface Elevation and Datum:

525.92 feet Surveyed

Estimated

Installation Date(s) 11/20/2003

Drilling Method Mud Rotary

Drilling Contractor Kendrick Enterprises LLC

Drilling Fluid Bentonite/water

Development Technique(s) and Date(s)

Pump 11/25/03

Fluid Loss During Drilling NA gallons

Water Removed During Development 15 gallons

Static Depth to Water 2.04 feet below M.P.

Pumping Depth to Water Dry feet below M.P.

Pumping Duration 0.33 hours

Yield 0.75 gpm Date 11/25/2003

Specific Capacity _____ gpm/ft

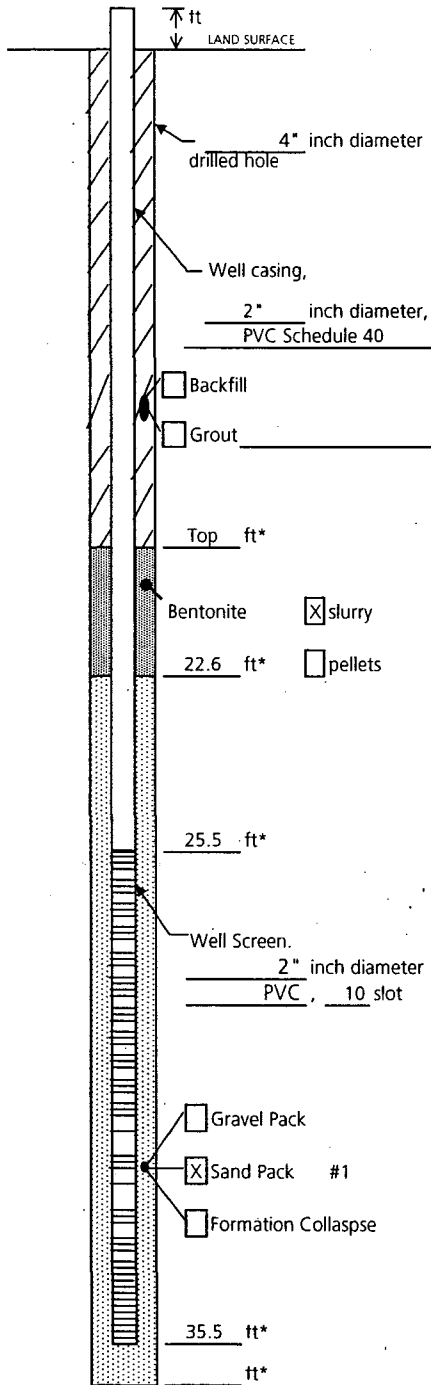
Well Purpose Monitoring Well

Remarks _____

Prepared by E. Wright

Well Construction Log

(Unconsolidated)



Measuring Point is
Top of Well Casing
Unless Otherwise Noted:

* Depth Below Land Surface

Project NJ000389.0009.00039 Well MW-355

Town/City Harriman

County Orange State NY

Permit No. _____

Land-Surface Elevation and Datum:

525.91 feet Surveyed

Estimated

Installation Date(s) 11/20/2003

Drilling Method Mud Rotary

Drilling Contractor Kendrick Enterprises LLC

Drilling Fluid Bentonite/water

Development Technique(s) and Date(s)

Pump 11/25/03

Fluid Loss During Drilling NA gallons

Water Removed During Development 20 gallons

Static Depth to Water 1.60 feet below M.P.

Pumping Depth to Water _____ feet below M.P.

Pumping Duration 0.33 hours

Yield 1.0 gpm Date 11/25/2003

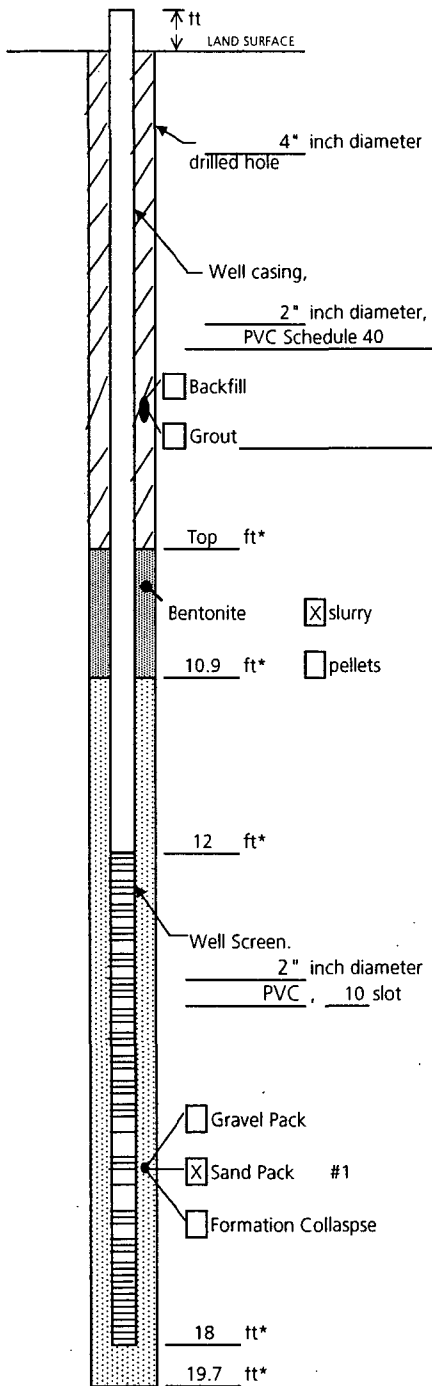
Specific Capacity _____ gpm/ft

Well Purpose Monitoring Well

Remarks _____

Prepared by E. Wright

Well Construction Log
(Unconsolidated)



Measuring Point is
Top of Well Casing
Unless Otherwise Noted.

* Depth Below Land Surface

Project NJ000389.0009.00039 Well MW-36AQ

Town/City Harriman

County Orange State NY

Permit No. _____

Land-Surface Elevation and Datum:

526.44 feet Surveyed

Estimated

Installation Date(s) 11/21/2003

Drilling Method Mud Rotary

Drilling Contractor Kendrick Enterprises LLC

Drilling Fluid Bentonite/water

Development Technique(s) and Date(s)

Pump 11/25/03

Fluid Loss During Drilling NA gallons

Water Removed During Development 15 gallons

Static Depth to Water 2.28 feet below M.P.

Pumping Depth to Water Dry feet below M.P.

Pumping Duration 0.3 hours

Yield 0.75 gpm Date 11/25/2003

Specific Capacity _____ gpm/ft

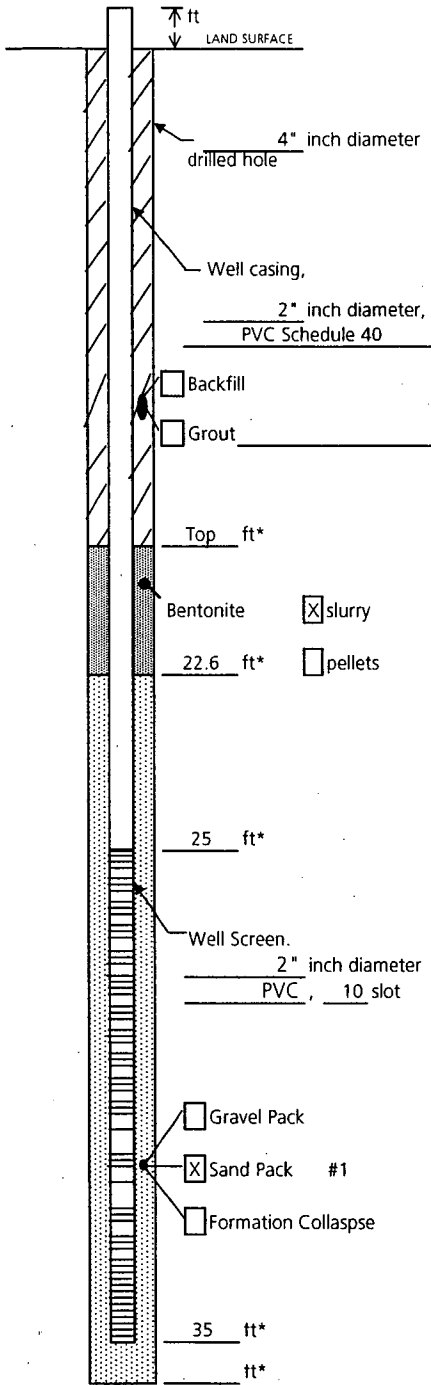
Well Purpose Monitoring Well

Remarks 1.75 bags of sand

Prepared by E.Wright

Well Construction Log

(Unconsolidated)



Measuring Point is
Top of Well Casing
Unless Otherwise Noted.

* Depth Below Land Surface

Project NJ000389.0009.00039 Well MW-365

Town/City Harriman

County Orange State NY

Permit No. _____

Land-Surface Elevation and Datum:

526.44 feet Surveyed

Estimated

Installation Date(s) 11/21/2003

Drilling Method Mud Rotary

Drilling Contractor Kendrick Enterprises LLC

Drilling Fluid Bentonite/water

Development Technique(s) and Date(s)

Pump 11/25/03

Fluid Loss During Drilling NA gallons

Water Removed During Development 45 gallons

Static Depth to Water 2.19 feet below M.P.

Pumping Depth to Water _____ feet below M.P.

Pumping Duration 1 hours

Yield 0.75 gpm Date 11/25/2003

Specific Capacity _____ gpm/ft

Well Purpose Monitoring Well

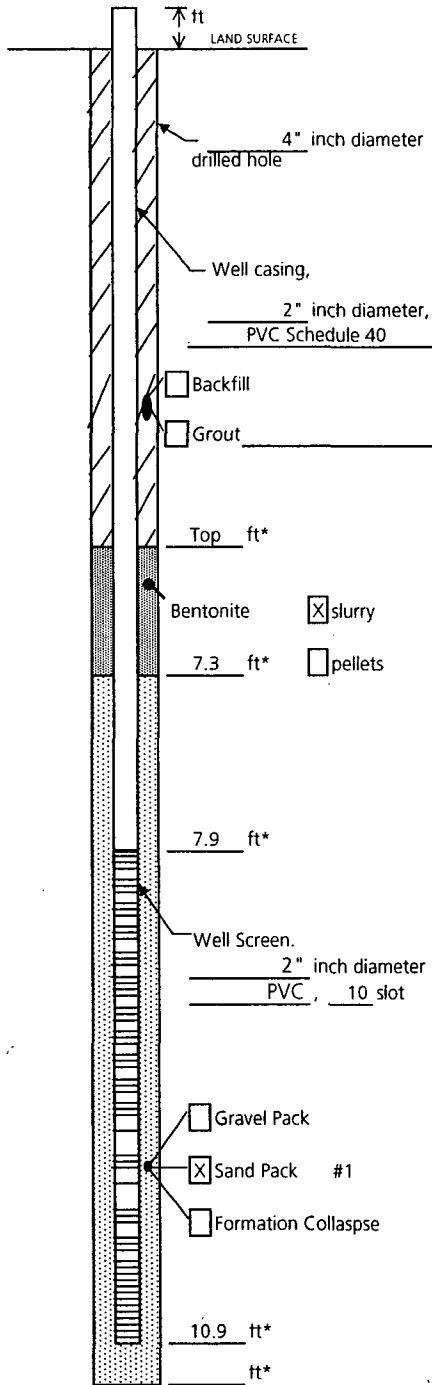
Remarks 2.5 bags of sand #1

1 bag of bentonite

Prepared by E. Wright

Well Construction Log

(Unconsolidated)



Measuring Point is Top of Well Casing Unless Otherwise Noted.

* Depth Below Land Surface

Project NJ000389.0009.00039 Well MW-37AQ

Town/City Harriman

County Orange State NY

Permit No. _____

Land-Surface Elevation and Datum:

526.06 feet Surveyed

Estimated

Installation Date(s) 11/24/2003

Drilling Method Mud Rotary

Drilling Contractor Kendrick Enterprises LLC

Drilling Fluid Bentonite/water

Development Technique(s) and Date(s)

Pump 11/26/03

Fluid Loss During Drilling NA gallons

Water Removed During Development 15 gallons

Static Depth to Water 1.05 feet below M.P.

Pumping Depth to Water Dry feet below M.P.

Pumping Duration 0.33 hours

Yield 0.75 gpm Date 11/25/2003

Specific Capacity _____ gpm/ft

Well Purpose Monitoring Well

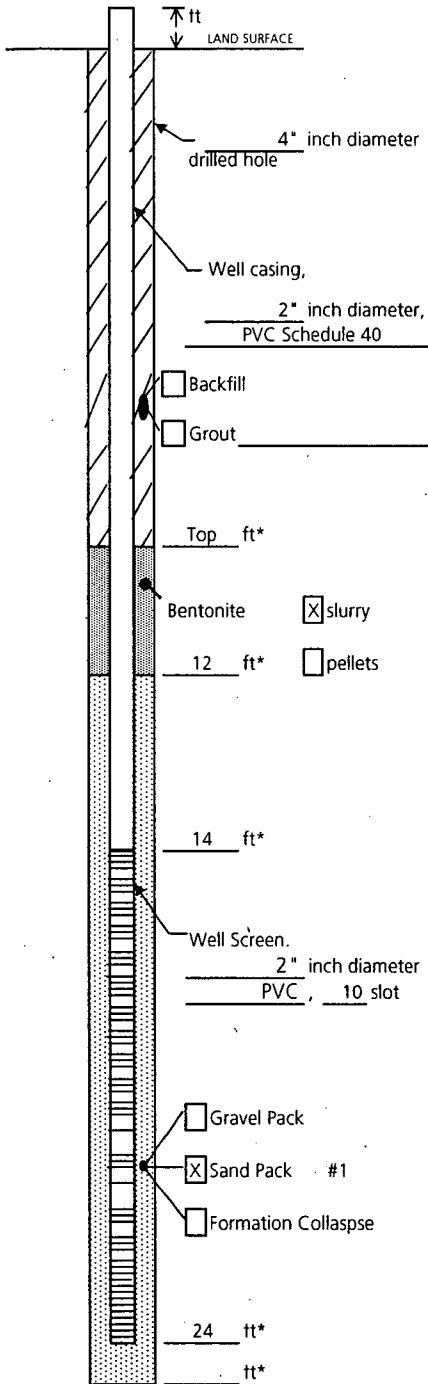
Remarks 3/4 bags of sand #1

1/3 bags of bentonite

Prepared by E. Wright

Well Construction Log

(Unconsolidated)



Measuring Point is
Top of Well Casing
Unless Otherwise Noted.

* Depth Below Land Surface

Project NJ000389.0009.00039 Well MW-37S

Town/City Harriman

County Orange State NY

Permit No. _____

Land-Surface Elevation and Datum:

526.06 feet Surveyed

Estimated

Installation Date(s) 11/24/2003

Drilling Method Mud Rotary

Drilling Contractor Kendrick Enterprises LLC

Drilling Fluid Bentonite/water

Development Technique(s) and Date(s)

Pump 11/26/03

Fluid Loss During Drilling NA gallons

Water Removed During Development 45 gallons

Static Depth to Water 0.72 feet below M.P.

Pumping Depth to Water _____ feet below M.P.

Pumping Duration 1 hours

Yield 0.75 gpm Date 11/26/2003

Specific Capacity _____ gpm/ft

Well Purpose Monitoring Well

Remarks 2.75 bags of sand

3/4 bags of bentonite

Prepared by E. Wright



APPENDIX C



ARCADIS

Appendix C

Groundwater Sampling
Logs

ARCADIS G&M
Groundwater Sampling Form

Project Number: NJ000389.0009 Task: 00039 Well ID: MW-35AQ
 Date: 12/11/03 Sampled By: K. Banach/M. Lorenz
 Sampling Time: 1446 Recorded By: K. Banach/M. Lorenz
 Weather: Cloudy, 40⁰ Coded Replicate No.: _____

INSTRUMENT IDENTIFICATION

	PID	Water-Level Meter	Water Quality Meter(s)
Serial #:		Heron Dipper T	YSI - 600 XL Flow Cell

PURGING INFORMATION

Casing Material: PVC Purge Method: QED Bladder Pump
 Casing Diameter: _____ Volumes to be Purged: _____
 Total Depth: 19.57 Total Volume Purged: _____
 Depth to Water: 2.04 Pump on: 1411 Off: 1508
 Water Column: _____
 Gallons/Foot: _____
 Gallons in Well: _____

FIELD PARAMETERS											
Time	Minutes Elapsed	Rate (ml/m)	Gallons Purged	Turbidity (NTUs)	REDOX (mV)	pH (SI Units)	Conductivity (µmhos/cm)	Temp (°C)	Depth to Water	Diss. Oxygen	Comments
1415	4	300			-134.0	6.73	2624	13.97	2.19	0.46	
1420	9	300			-141.6	6.69	2654	14.18	2.22	0.23	
1425	14	300			-143.4	6.67	2660	14.11	2.19	0.19	
1430	19	300			-146.0	6.67	2660	14.06	2.21	0.18	
1435	24	300			-148.6	6.67	2663	13.99	2.20	0.17	
1440	29	300			-148.7	6.66	2663	13.97	2.21	0.17	
1445	34	300			-149.2	6.66	2659	13.96	2.20	0.18	

OBSERVATIONS DURING SAMPLING

Well Condition: OK Purge Water Disposal: Onto the ground
 Color: Dark Gray Turbidity(qualitative): Turbid
 Odor: Yes Other (OVA, HNU, etc.): _____

ARCADIS G&M
Groundwater Sampling Form

Project Number: NJ000389.0009 Task: 00039 Well ID: MW-355
 Date: 12/11/03 Sampled By: K. Banach/M. Lorenz
 Sampling Time: 1456 Recorded By: K. Banach/M. Lorenz
 Weather: Cloudy, 40° Coded Replicate No.: _____

INSTRUMENT IDENTIFICATION

	PID	Water-Level Meter	Water Quality Meter(s)
Serial #:		Heron Dipper T	YSI - 600 XL Flow Cell

PURGING INFORMATION

Casing Material: PVC Purge Method: QED Bladder Pump
 Casing Diameter: _____ Volumes to be Purged: _____
 Total Depth: 34.95 Total Volume Purged: _____
 Depth to Water: 1.60 Pump on: 1410 Off: 1500
 Water Column: _____
 Gallons/Foot: _____
 Gallons in Well: _____

FIELD PARAMETERS											
Time	Minutes Elapsed	Rate (ml/m)	Gallons Purged	Turbidity (NTUs)	REDOX (mV)	pH (SI Units)	Conductivity (µmhos/cm)	Temp (°C)	Depth to Water	Diss. Oxygen	Comments
1415	5	400			-138.8	7.18	1306	13.66	1.60	0.49	
1420	10	400			-147.2	7.15	1388	13.79	1.60	0.24	
1425	15	400			-170.7	7.16	1462	13.85	1.60	0.18	
1430	20	400			-185.3	7.16	1517	13.85	1.60	0.14	
1435	25	400			-192.5	7.16	1550	13.86	1.60	0.12	
1440	30	400				7.17			1.60	0.10	
1445	35	400			-202.0	7.17	1588	13.84	1.60	0.09	
1450	40	400			-205.0	7.17	1602	13.83	1.60	0.08	
1455	45	400			-202.6	7.17	1614	13.82	1.60	0.08	

OBSERVATIONS DURING SAMPLING

Well Condition: OK Purge Water Disposal: Onto the ground
 Color: Clear Turbidity(qualitative): _____
 Odor: Yes Other (OVA, HNU,etc.): _____

ARCADIS G&M
Groundwater Sampling Form

Project Number: NJ000389.0009 Task: 00039 Well ID: MW-36AQ
 Date: 12/11/03 Sampled By: K. Banach/M. Lorenz/C. Tafur
 Sampling Time: 1316 Recorded By: K. Banach/M. Lorenz/C. Tafur
 Weather: Cloudy, 40^o Coded Replicate No.: _____

INSTRUMENT IDENTIFICATION

	PID	Water-Level Meter	Water Quality Meter(s)
Serial #:		Heron Dipper T	YSI - 600 XL Flow Cell

PURGING INFORMATION

Casing Material: PVC Purge Method: QED Bladder Pump
 Casing Diameter: _____ Volumes to be Purged: _____
 Total Depth: 17.5 Total Volume Purged: _____
 Depth to Water: 2.28 Pump on: 1241 Off: 1320
 Water Column: _____
 Gallons/Foot: _____
 Gallons in Well: _____

FIELD PARAMETERS											
Time	Minutes Elapsed	Rate (ml/m)	Gallons Purged	Turbidity (NTUs)	REDOX (mV)	pH (SI Units)	Conductivity (µmhos/cm)	Temp (°C)	Depth to Water	Diss. Oxygen	Comments
1250	9	400			-181.5	7.06	2176	14.68	2.88	0.23	
1255	14	400			-192.0	7.06	2198	14.79	2.98	0.17	
1300	19	400			-195.7	7.05	2204	14.82	2.97	0.15	
1305	24	400			-198.0	7.05	2208	14.82	2.98	0.14	
1310	29	400			-199.4	7.05	2210	14.85	2.98	0.13	
1315	34	400			-201.1	7.05	2209	14.88	2.98	0.12	

OBSERVATIONS DURING SAMPLING

Well Condition: New Purge Water Disposal: On site containment
 Color: Gray Turbidity(qualitative): Very Turbid
 Odor: None Other (OVA, HNU,etc.): _____

ARCADIS G&M
Groundwater Sampling Form

Project Number: NJ000389.0009 Task: 00039 Well ID: MW-365
 Date: 12/11/03 Sampled By: K. Banach/M. Lorenz/C. Tafur
 Sampling Time: 1321 Recorded By: K. Banach/M. Lorenz/C. Tafur
 Weather: Cloudy/Drizzle, 40° Coded Replicate No.: _____

INSTRUMENT IDENTIFICATION

	PID	Water-Level Meter	Water Quality Meter(s)
Serial #:		Heron Dipper T	YSI - 600 XL Flow Cell

PURGING INFORMATION

Casing Material: PVC Purge Method: QED Bladder Pump
 Casing Diameter: _____ Volumes to be Purged: _____
 Total Depth: 34.95 Total Volume Purged: _____
 Depth to Water: 2.19 Pump on: 1241 Off: 1336
 Water Column: _____
 Gallons/Foot: _____
 Gallons in Well: _____

FIELD PARAMETERS											
Time	Minutes Elapsed	Rate (ml/m)	Gallons Purged	Turbidity (NTUs)	REDOX (mV)	pH (SI Units)	Conductivity (µmhos/cm)	Temp (°C)	Depth to Water	Diss. Oxygen	Comments
1250	9	325			-190.2	7.23	1442	13.89	2.16	0.61	
1255	14	325			-204.5	7.25	1543	14.21	2.20	0.23	
1300	19	325			-206.2	7.24	1527	14.29	2.20	0.20	
1305	24	325			-210.3	7.19	1519	14.39	2.20	0.15	
1310	29	325			-213.7	7.17	1524	14.39	2.20	0.13	
1315	34	325			-216.2	7.16	1525	14.40	2.20	0.12	
1320	39	325			-216.4	7.16	1519	14.43	2.20	0.11	

OBSERVATIONS DURING SAMPLING

Well Condition: OK Purge Water Disposal: On site containment
 Color: Clear Turbidity(qualitative): Clear
 Odor: Yes Other (OVA, HNU,etc.): _____

ARCADIS G&M
Groundwater Sampling Form

Project Number: NJ000389.0009 Task: 00039 Well ID: MW-375
 Date: 12/11/03 Sampled By: K. Banach/M. Lorenz
 Sampling Time: 1047 Recorded By: K. Banach/M. Lorenz
 Weather: Rain, 50° Coded Replicate No.: _____

INSTRUMENT IDENTIFICATION

	PID	Water-Level Meter	Water Quality Meter(s)
Serial #:		Heron Dipper T	YSI - 600 XL Flow Cell

PURGING INFORMATION

Casing Material: PVC Purge Method: QED Bladder Pump
 Casing Diameter: _____ Volumes to be Purged: _____
 Total Depth: 23.29 Total Volume Purged: _____
 Depth to Water: 0.72 Pump on: 1019 Off: 1105
 Water Column: _____
 Gallons/Foot: _____
 Gallons in Well: _____

FIELD PARAMETERS											
Time	Minutes Elapsed	Rate (ml/m)	Gallons Purged	Turbidity (NTUs)	REDOX (mV)	pH (SI Units)	Conductivity (µmhos/cm)	Temp (°C)	Depth to Water	Diss. Oxygen	Comments
1025	6	400			-226.9	7.20	1688	15.62	1.14	0.27	
1030	11	400			-226.4	7.20	1689	15.64	1.14	0.22	
1035	16	400			-225.8	7.20	1687	15.67	1.17	0.20	
1040	21	400			-225.4	7.20	1684	15.64	1.14	0.19	
1045	26	400			-224.6	7.20	1681	15.68	1.14	0.18	

OBSERVATIONS DURING SAMPLING

Well Condition: OK Purge Water Disposal: Onto the ground
 Color: Cloudy to Clear Turbidity(qualitative): _____
 Odor: Yes Other (OVA, HNU, etc.): _____

*2" Fernco with 1' extension to get out of standing water.