

Report, hw. 336006, 2007-10-11, GW, REPORT.

2007-10. pdf

**Groundwater Quality
Assessment, Groundwater
Remediation Progress and
Proposed Updated Remediation
Program**

Supplemental Report

Nepera Harriman Site
Harriman, New York

October 2007

Michael Mason, P.E.
New York State Department of Environmental Conservation
Division of Environmental Remediation
625 Broadway
Albany, New York 12233-7013

ARCADIS U.S., Inc.
6 Terry Drive
Suite 300
Newtown
Pennsylvania, 18940
Tel 267 685 1800
Fax 267 685 1801
www.arcadis-us.com

Subject:

Proposed Revision to the Groundwater Monitoring Program
Harriman Site, Harriman, New York

ENVIRONMENT

Dear Mr. Mason:

Date:
10 October 2007

ARCADIS G&M, Inc. (ARCADIS) has prepared this revised groundwater monitoring program, on behalf of the Maybrook and Harriman Trust (Trust), for the Harriman Site (Site). This revised program is proposed to commence with the October 2007 semi-annual groundwater monitoring event and will continue for subsequent groundwater monitoring events until such time that it is further revised. Please note that the program presented herein includes several minor changes from the proposed program submitted to the NYSDEC in January 2007. The January 2007 proposed program should be discarded.

Contact:
Alan Robinson

Phone:
267.685.1800

Email:
amrobinson@arcadis-us.com

The current groundwater monitoring program and proposed changes are outlined below:

Our ref:
NJ000389.0008.00002

January 2006 Groundwater Monitoring Program (Current Program)

- Monitor depth to water and compute groundwater elevations in all bedrock, overburden aquitard and overburden aquifer monitoring wells on a semi-annual basis.
- Monitor groundwater quality in overburden perched/aquitard wells (MW-15S, MW-17S, MW-26S, MW-28S, MW-29S, MW-34, PZ-4), overburden aquifer wells (MW-1S, MW-5S, MW-7S, MW-8S, MW-16S, MW-20S, MW-24S, MW-25S, , MW-33, OW-6, OW-7, RW-1R, MW-53D), and bedrock wells (MW-6D, MW-20D, MW-26D) on a semi-annual basis. BTEX and SVOCs testing performed semi-annually.
- Monitor well MW-24S, on a semi-annual basis for mercury.

Proposed October 2007 Groundwater Monitoring Program

- Monitor depth to water and compute groundwater elevations in all overburden aquifer monitoring wells on a semi-annual basis. Prepare a groundwater contour map one time a year using January data
- Monitor groundwater quality in eight overburden aquifer plume fringe and sentinel aquifer wells and three bedrock aquifer sentinel wells. All wells to be sampled are listed in Table G-1 and located on Figure 2-2. Semi-annual sampling events will be in April and October. Bedrock aquifer wells MW-6D and MW-26D will be sampled annually only (in October) due to an extended history of samples meeting NYSDEC SCGs. Wells MW-27D, which has not been sampled since 2000 and MW-12S, which had not been sampled between 2000 and 2006, will be tested for BTEX and site-specific SVOCs in October 2007. The other wells will be tested for BTEX only. It is anticipated that subsequent samples from MW-27D and MW-12S will be tested for BTEX only. The basis for not analyzing for SVOCs is provided in the October 2007 Supplemental Report.
- Monitor groundwater quality in eight overburden source area, plume centerline and plume lateral wells and one bedrock plume centerline well on a semi-annual basis. BTEX will be tested in all wells. SVOCs will be tested in source area well OW-6 due to persistent elevated SVOC concentrations, probably associated with biosparge well performance failure in this area (corrected in August 2007) and PZ-2, which has not been sampled since 2000. The SVOC analysis for the PZ-2 samples will not be performed if October 2007 results are consistent with 2000 results.
- Monitor MW-24S in the October sampling event for total and dissolved mercury.
- Field measured parameters – redox, dissolved oxygen, pH, and specific conductance – will be measured in all wells sampled.

Site groundwater monitoring well information is provided in Table G-1. Well locations and historical groundwater quality results are provided on Figure 2-2 and summarized in Table G-2. All supporting materials are enclosed herein.

These program changes are proposed for the following reasons:

- Groundwater elevations fluctuate seasonally and in response to precipitation, but groundwater flow direction at the site remains consistent. Annual water table contour maps are sufficient to characterize site groundwater flow direction.
- Data from several of the wells sampled on a routine basis no longer provide useful data. This includes upgradient wells, wells screened in the aquitard, wells screened in the shallow or perched aquifer above the aquitard that are not contaminated, and wells that are slightly contaminated, stable, and upgradient from the plume fringe. These wells will no longer be included as part of the routine sampling program.
- The site-specific SVOC compounds – pyridine, alpha-picoline, and 2-amino-pyridine – are detected at concentrations lower than benzene and increase and decrease in a consistent pattern as benzene. Data for these compounds currently provide no useful data not already provided by the benzene data.
- Two of the three wells sampled for mercury – MW-28S and MW-29S - are screened within the aquitard. As a consequence, only MW-24S, which is screened in the sand and is downgradient from the calcium sulfate fill area, will be sampled and tested for mercury.

Sampling, analytical, and reporting procedures will be updated in the Operations, Management and Monitoring Plan to be provided after the proposed revised monitoring program and the Explanation of Significant Differences are reviewed and approved.

Should you have any questions or wish to discuss the elements of this program, please do not hesitate to contact me.

Sincerely,

ARCADIS U.S., Inc.

Mr. Michael Mason
10 October 2007

A handwritten signature in black ink, appearing to read "Alan M. Robinson". The signature is fluid and cursive, with the first name "Alan" and last name "Robinson" clearly distinguishable.

Alan M. Robinson, P.G.
Project Manager

Copies:

S. Levine, Cambrex

B. Wong, Pfizer

G. Hollerbach, Quantum Management Group

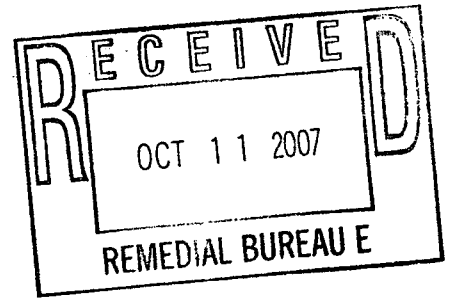

**Groundwater Quality
Assessment, Groundwater
Remediation Progress and
Proposed Updated Remediation
Program**

Supplemental Report

Nepera Harriman Site
Harriman, New York

October 2007

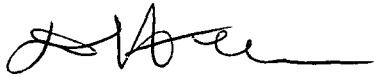

David Heuer
Staff Scientist

 for Brad Koons

Brad Koons
Senior Engineer

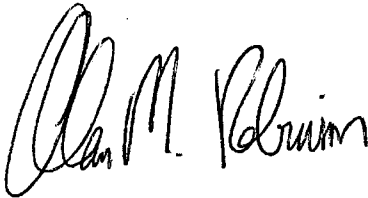

Alan M. Robinson, P.G.
Project Manager
Vice President

**Groundwater Quality
Assessment, Groundwater
Remediation Progress and
Proposed Updated
Remediation Program
Supplemental Report**

Nepera Harriman Site
Harriman, New York

Prepared for:
Maybrook and Harriman Trust

Prepared by:
ARCADIS U.S., Inc.
6 Terry Drive
Suite 300
Newtown
Pennsylvania 18940
Tel 267.685.1800
Fax 267.685.1801

Our Ref.:
NJ000389.0007

Date:
October 2007

This document is intended only for the use of the individual or entity for which it was prepared and may contain information that is privileged, confidential and exempt from disclosure under applicable law. Any dissemination, distribution or copying of this document is strictly prohibited.

Table of Contents

1. Introduction	1
1.1 Background and Purpose	1
1.2 Monitoring Well Terminology Modification	3
2. Pre-remediation, Circa-1988, Plume Map	3
3. October 2006 Geoprobe Soils Data and January 2007 Groundwater Quality Data	4
3.1 October 2006 Geoprobe Soils Data	4
3.2 January 2007 Groundwater Quality Data	6
4. Biogeochemical Processes Driving the Degradation of Benzene and Other Organic Compounds in Site Groundwater	6
4.1 Mechanics of Biodegradation	6
4.2 Site Chemical Biodegradation Properties	8
4.3 Biosparge System	11
4.4 Natural Attenuation	11
4.5 Groundwater Contaminant Concentration Trend Analysis	12
4.6 Electron Acceptor Concentrations	15
5. Plume Fringe and Sentinel Monitoring Wells Program and ROD-mandated Groundwater Quality Management Program	16
6. Spatial and Temporal Coverage and Gaps in the Overburden Aquifer Groundwater Monitoring Program	17
6.1 Existing Monitoring Wells	18
6.2 Source Area Wells	19
6.3 Plume Lateral Extent Wells	19
6.4 Plume Fringe and Sentinel Wells	20
6.5 Proposed Enhanced Plume Management Monitoring Well Program	20
7. Spatial and Temporal Coverage and Gaps in the Bedrock Aquifer Groundwater Monitoring Program and Relationship to Town of Harriman Water Supply Wells	21

Table of Contents

7.1	Existing Monitoring Wells	21
7.2	Public Water Supply Well Pump Rate Test	22
7.4	Summary of Bedrock Groundwater	24
7.5	Proposed Monitoring	24
8.	Support for ARCADIS' Proposal to Substantially Reduce the Testing of Pyridine and Related Semi-volatile Organic Compounds	25
9.	MW-1S Historical Data	26
10.	Summary of Findings and Conclusions	26
11.	Proposed Updated Remedial Approach	29
11.1	Prepare and Put into Effect an Explanation of Significant Differences to Modify the ROD Remedy from Pump and Treat to Biosparge and Monitored Natural Attenuation	29
11.2	Continue Operation of Plumes A and B Biosparge Systems	30
11.3	Continue Plume C Monitored Natural Attenuation	30
11.4	Discontinue IRM	30
11.5	Add Bedrock Monitoring Well and Continue Bedrock Groundwater Quality Natural Attenuation Monitoring at MW-20D	31
11.6	Enhanced Groundwater Monitoring Well Program	31
11.7	Environmental Easement	31
11.8	Well Decommissioning	31
11.9	Revised Groundwater Monitoring Program	32
11.10	Operations, Maintenance, and Monitor (OM&M) Plan	32
11.11	Criteria to Discontinue Plumes A and B Biosparge System	32
11.12	Use of Draft DER-10 Guidance	33

Tables

Table 4-1	2000 Geochemical Water Quality Data
Table 4-2	2006 Geochemical Water Quality Data
Table 6-1	Monitoring Well Information

Figures

- Figure 2-1 Pre-remediation "Circa" 1988 Overburden Aquifer Benzene Plume Map
- Figure 2-2 June 2007 Overburden Aquifer Benzene Concentrations Plume Map and Historical Groundwater Sampling Results
- Figure 3-1 OW-6 Area Soil and Groundwater Results, October 2006
- Figure 4-1 Groundwater Quality Trends for Select Monitoring Wells
- Figure 6-1 1991 RI Test Pit Locations with Elevated VOCs and Soil Gas Concentration Contours
- Figure 6-2 Proposed Enhanced Overburden Aquifer Monitoring Program – Phase 1 Locations
- Figure 9-1 MW-1 Historical Influent Groundwater Quality Data

Appendices

- A OW-6 Area Geoprobe Logs and Soil and Groundwater Analytical Data, October 2006
- B Historical Groundwater Quality Data
- C Mann-Kendall Test
- D Well Logs
- E Benzene, Pyridine and Alpha-Picoline Concentrations Graph
- F 1988 Town of Harriman Water Supply Well OR-7 Pumping Test Report
- G Proposed Groundwater Monitoring Program

1. Introduction

1.1 Background and Purpose

In January 2007, ARCADIS, on behalf of the Maybrook and Harriman Environmental Trust (Trust), submitted a Groundwater Quality Assessment, Groundwater Remediation Progress and Proposed Updated Remediation Program (referred to herein as 'January 2007 report') to the New York State Department of Environmental Conservation (NYSDEC). Simultaneously, ARCADIS submitted a preliminary draft Explanation of Significant Differences (ESD) for the NYSDEC's consideration.

The January 2007 report was prepared for the following purposes:

- Provide and discuss the current groundwater quality conditions at the site as of June 2006
- Discuss the progress and success to date of the groundwater remediation program
- Present the basis for the preliminary draft of the Explanation of Significant Differences (ESD) document submitted to the NYSDEC
- Provide and support a path forward for achievement of the ROD/ESD remediation goals for the site.

In March 2007, representatives of the Trust and ARCADIS met with NYSDEC case management and NYS Department of Health (NYSDOH) staff to discuss the findings and conclusions presented in the January 2007 report and the elements of the proposed ESD. It was agreed by all at the meeting that ARCADIS would provide a supplemental report, designed to support the preliminary draft ESD, addressing the following subjects:

- Pre-remediation program plume map (circa 1988)
- October 2006 Geoprobe soils data and January 2007 groundwater quality data
- Biogeochemical processes driving the degradation of benzene and other organic compounds in site groundwater

- Relationship between groundwater quality trends/groundwater remediation progress to date in achieving groundwater goals and the role of biosparge, natural biological degradation and other site management/remediation work performed to date in achieving this progress
- Plume fringe well and sentinel well program groundwater quality monitoring in relation to the ROD-mandated groundwater quality management program
- Spatial and temporal coverage and gaps in the overburden aquifer groundwater monitoring program
- Spatial and temporal coverage and gaps in the bedrock aquifer groundwater monitoring program and relationship to Town of Harriman water supply wells
- Support for ARCADIS' proposal to substantially reduce the testing of pyridine and related semi-volatile organic compounds

Each of these subjects is addressed within this supplemental report. In addition, guidance provided in the 2002 NYSDEC Draft DER-10 Technical Guidance for Site Investigation and Remediation – are incorporated into this report. The final two sections of the January Report – Summary of Findings and Conclusions and Proposed Updated Remedial Approach - have been modified to incorporate information provided within this Supplemental Report and represented in Sections 10 and 11 herein.

The Maybrook and Harriman Environmental Trust has provided the additional information and program descriptions herein and in the January 2007 report. The Trust respectfully requests that the NYSDEC evaluate this information with a perspective to achieve the following objectives:

1. Evaluate the data in the short term and consider, support, and implement the revised preliminary draft Explanation of Significant Differences provided to the NYSDEC in Attachment 1 herein before the end of the year; and
2. Evaluate current data and future data when available to support and implement the Trust's long term Operation and Maintenance program objectives which will ultimately achieve the primary goals of the 1997 Record of Decision.

1.2 Monitoring Well Terminology Modification

During the March 2007 meeting it became apparent that certain terminology used in the January 2007 report (and earlier reports) was inconsistent with terminology used in draft DER-10. For the purposes of this and future reports, the following monitoring well category terminology from draft DER-10 will be used:

- Source area
- Plume centerline
- Plume lateral
- Plume fringe
- Sentinel

The proposed monitoring well category for each existing overburden aquifer and bedrock aquifer groundwater monitoring well is provided as part of Table 6-1.

2. Pre-remediation, Circa-1988, Plume Map

Benzene and other compounds (also referred to herein as compounds of concern [COCs]) were first detected in Site groundwater in 1985 when the first groundwater monitoring wells were installed. Additional wells were added in 1988, 1989, 1991, 1999, 2000, 2002 and 2003. Site remediation began in 1988 with drum and soil excavation in the vicinity of MW-16S and continued with groundwater pump and treat which began in 1990, more drum and soil excavation in 1999 to 2001, and biosparge beginning in December 2001.

To obtain a better appreciation of the groundwater remediation progress to date, ARCADIS has prepared Figure 2-1-Historical Groundwater Sampling Results/Benzene Plume Map Circa-1988 - Overburden Aquifer. This figure illustrates the extent of benzene in the overburden aquifer prior to the start of what has been a multi-element remediation program. The plume map is titled "circa-1988" because some liberties were taken. For those wells installed since 1988, most of which are in areas upgradient from the soil excavations, pumping wells and/or the biosparge points or are in areas not directly affected by any of these remediation elements, the highest concentration detected in each well to date was utilized in the circa-1988 plume map.

Another liberty taken is the inclusion of much of the tank farm/process area within the plume (the inferred [hatched] area in Figure 2-1), as there are no groundwater data for that area.

The circa-1988 benzene plume underlies approximately 25 acres of the site and extended across the entire site to the property line formed by the North Branch Ramapo River in the north and beyond the property line in the east. Benzene concentrations exceeding 100 ug/L and 1000 ug/L extended to and beyond the property line. Concentrations immediately upgradient from Arden House Road were above or close to 1000 ug/L.

The 2007 benzene plume provides a very different picture (Figure 2-2, Historical Groundwater Sampling Results and January 2007 Benzene Plume Map – Overburden Aquifer). Benzene concentrations at and beyond the property line are less than 1.0 ug/L. Of the three monitoring wells immediately downgradient or upgradient of Arden House Road, the benzene concentration is reported as <1.0 ug/L for two of the wells (MW-8 and MW-11) and 130 ug/L for the third (MW-37S). These results indicate shrinkage of the plume back toward the source area(s) and a decrease in concentrations along the plume centerlines. (Note that the inferred area included in the circa-1988 plume map has not been included on the 2007 plume map.) Based on the data available from the existing overburden aquifer monitoring wells, the area of the site underlain by the plume in 2007 (including the inferred area shown in Figure 2-1) is approximately six acres or 25 percent of the 1988 plume area, a 75 percent reduction in area..

3. October 2006 Geoprobe Soils Data and January 2007 Groundwater Quality Data

Two sets of data not provided as part of the January 2007 report, which were summarized during the March meeting, were the following: limited Geoprobe sampling data from the area near OW-6 obtained in October 2006 and January 2007 semi-annual groundwater data. This information is provided below.

3.1 October 2006 Geoprobe Soils Data

In accordance with ARCADIS' September 19, 2006 letter to the NYSDEC, ARCADIS implemented a program to advance eight Geoprobe borings to a depth of 25 to 30 ft in the vicinity of Biosparge Line A and monitoring well OW-6 (see Figure 3-1 for locations). The highest benzene concentrations obtained as part of recent semi-

annual groundwater sampling events have been in OW-6. The borings were performed to qualitatively characterize subsurface conditions upgradient from OW-6 for consideration for the possible installation of additional biosparge points. The work was not conceived as an investigation, hence there was no formal sampling program. Sample bottles were brought to the field in the event that conditions arose for which laboratory analyses might prove useful in guiding the selection of additional sparge points.

Geoprobe core recoveries were excellent (4-5 ft from 5 foot lengths). Cores were screened with a PID. Boring logs are provided in Appendix A. Geologic materials at each boring location were generally consistent. Two to four feet of fill were underlain by intervals of clayey silt and silt to a depth of about 20 feet. Below the clayey silt, the sediments graded from fine to coarse sand. The sand marks the top of the Site overburden aquifer.

Elevated PID readings were observed in borings GP-5, -6, -7 and -8, 60 to 120 feet west of OW-6. (PID readings are provided with the boring logs in Appendix A.) The highest readings were in the clayey-silt unit at 12 to 15 feet below ground surface (bgs). PID readings in the sand unit were orders of magnitude lower, when present. A field decision was made to collect one soil sample for laboratory analysis from four of the borings. The samples selected for analysis were from the location in the boring with the highest PID reading. Groundwater samples were collected in the sand unit occurring immediately beneath the clayey-silt unit in three borings where an elevated PID reading was observed in the sand unit portion of the core. Each of the four soil samples and three groundwater samples were analyzed for volatile organic compounds (VOCs).

Benzene was the only compound detected at concentrations greater than 1 milligram per kilogram (mg/kg) in the soil samples. Compounds detected and associated concentrations are provided in Figure 3-1. GP-5, GP-6 and GP-8 contained benzene at 12 mg/kg, 26 mg/kg and 53 mg/kg, respectively. The groundwater grab sample from GP-8 had a benzene concentration of 420 micrograms per liter (ug/L).

The GP-5/GP-8 area is hydraulically upgradient from OW-6 and Sparge Line A (BS-1 through BS-8). The PID readings obtained from the October 2006 borings contrast with those obtained from the 2001 OW-6 boring (Appendix D); at OW-6, there were no PID readings recorded above background.

Based on the information obtained as part of the limited testing performed in October 2006, it is evident that benzene is present in at least one portion of the overburden aquitard (clayey silt). The data obtained from these borings indicate that the source area for the impacted groundwater observed in monitoring well OW-6 may be 120 or more feet west and upgradient from OW-6 and sparge Line A.

No decision has been made to date as to whether additional sparge points will be installed in this area. A plan to enhance the plume management monitoring program to is provided in Section 6.5 herein.

3.2 January 2007 Groundwater Quality Data

Fourteen wells were sampled in January 2007 as part the routine semi-annual groundwater monitoring program. Three additional wells could not be sampled due to ice encapsulating the flush mounts. Data are provided in Appendix B

January 2007 groundwater quality data were consistent with data obtained since extraction wells MW-1 and RW-1R were taken off line for repair and modification in 2004. Benzene was not detected in plume fringe and sentinel wells MW-24S, MW-1S, MW-7S, MW-11S, MW-8S, and RW-1R and was detected at the 1 ug/L NYSDEC Standard/Criteria/Guidance (SCG) level in MW-12S. Toluene was detected in RW-1R at 3 ug/L, below the SCG of 5 ug/L. Benzene concentrations from wells within the body of the plumes were generally consistent with recent past data.

4. Biogeochemical Processes Driving the Degradation of Benzene and Other Organic Compounds in Site Groundwater

The January 2007 report described groundwater quality conditions at the Site, but did not provide detailed information about natural and biosparge-enhanced biological degradation processes at work at the site. Background information on the mechanics of bioremediation and information relevant to the Site are provided below.

4.1 Mechanics of Biodegradation

Microorganisms are found in all soils, often in staggering numbers. A single ounce of topsoil can contain millions to billions of microscopic organisms. The reason for this abundance of life is simple; soil contains a wealth of food varying from dead plant and animal matter to plant root exudates. These readily available food sources and lack of competition from higher-order life forms allow for a thriving soil microbial ecosystem.

Bacteria consume food on a chemical compound level. Because soil food sources are complex organic materials comprised of many chemical compounds, soil bacteria have the capacity to metabolize a wide variety of compounds to generate energy. This is significant when considering the effect of chemical releases to the environment. While the chemicals are of concern to human health, many are commonly encountered in soil systems during decay of organic matter and are simply another food source for the soil bacteria. Often the chemical release to soil will increase the microbial population as the introduced chemical is more readily accessible for consumption than decaying plant and animal organic matter.

There are two classes of compounds that bacteria use for metabolism: electron donors and electron acceptors. Electron donors are reduced compounds that can be thought of as "food" that is consumed by the cell. Electron acceptors are oxidized compounds that are respired in conjunction with electron donor consumption. Humans and all multi-cellular organisms use oxygen as the sole electron acceptor in their metabolic processes. Microorganisms, however, can respire or "breathe" a broader spectrum of electron acceptor compounds than the higher-order life forms. Common electron acceptor compounds found in soil moisture and aquifers and some example electron donor compounds and products are presented below.

Electron Donors ("Food Sources")	Electron Acceptors
<ul style="list-style-type: none"> • Heating oil • Gasoline • Ethanol • Benzene • Toluene • Pyridine • Picoline 	<ul style="list-style-type: none"> • Oxygen (O₂) • Nitrate (NO₃) • Manganese (IV) (Mn⁺⁴) • Ferric Iron (Fe⁺³) • Sulfate (SO₄) • Carbon Dioxide (CO₂)

A typical microbial metabolic reaction can be expressed as:

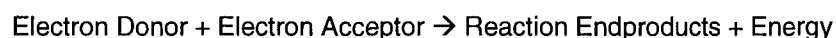

The energy yield of the metabolic reaction is dependant on the electron acceptor used in the reaction. Relative energy yields for common electron acceptors found in soil moisture and aquifers are presented below.

	Electron Acceptor	Energy Yield (kilocalorie/mole)
Most Energetic	Oxygen	-120
	Nitrate	-114
	Manganese (IV)	-81
	Ferric Iron	-28
	Sulfate	-25
Least Energetic	Carbon Dioxide	-22

Oxygen yields the greatest amount of energy for every unit of electron donor compound consumed. It is advantageous for microorganisms to respire the higher energy yielding electron acceptors. Higher energy yields under aerobic (with oxygen) conditions allow for more vigorous metabolism and faster cellular growth and reproduction. In contrast, microbes that use the lower yield electron acceptors such as sulfate and carbon dioxide under anaerobic (without oxygen) conditions are relatively slow-growing and lethargic. Some electron donor contaminant compounds are thought to be recalcitrant under anaerobic conditions. This can be due to a functional limitation (reaction cannot proceed without oxygen) or due to extremely low reaction rates under anaerobic conditions that make anaerobic transformation negligible.

4.2 Site Chemical Biodegradation Properties

The Site groundwater is impacted by three main compounds of concern; benzene, pyridine, and alpha-picoline (methyl pyridine). These COCs are both naturally occurring compounds and are widely formulated and used in industry and in commercial products (e.g., benzene is an additive in gasoline). Due to this wide use, benzene, pyridine, and picoline have been found at numerous environmentally impacted sites. Studies have been conducted to determine the fate of these compounds in the environment. Specifically, many researchers have focused on biodegradation of these compounds under aerobic and anaerobic conditions.

Compound	Biodegradation Occurs		References
	Aerobic Conditions	Anaerobic Conditions	
Benzene	Y	Y	Anderson, R. T. and D. R. Lovley. 2000. Anaerobic Bioremediation of Benzene under Sulfate-Reducing Conditions in a Petroleum-Contaminated Aquifer. Environ. Sci. Technol., 34 (11), 2261-2266; Chakraborty, R. and J. D. Coates. 2004.

**Groundwater Quality
Assessment, Groundwater
Remediation Progress and
Proposed Updated
Remediation Program
Supplemental Report**

Nepera Harriman Site
Harriman, New York

			Anaerobic degradation of monoaromatic hydrocarbons. Journal Applied Microbiology and Biotechnology. Vol. 64, Number 4, pages 437-446; Lovley, Derek R., John D. Coates, Joan C. Woodward, and Elizabeth J. P. Phillips. 1995. Benzene Oxidation Coupled to Sulfate Reduction. Applied and Environmental Microbiology. Vol 61, No.3, pp 953-958.
Pyridine	Y	Y	Kaiser J. P., Y. Feng and J. M. Bollag. 1996. Microbial metabolism of pyridine, quinoline, acridine, and their derivatives under aerobic and anaerobic conditions. Microbiol. Rev. Vol 60, No. 3, pp. 483-498
Picoline	Y	Y	Kaiser, J. P., R. D. Minard, and J. M. Bollag. 1993. Transformation of 3- and 4-Picoline under Sulfate-Reducing Conditions. Applied and Environmental Microbiology. Vol. 59, No. 3, pp. 701-705; Kaiser et al (1996), Ibid.

Under laboratory conditions, biodegradation rates for benzene range from a half-life of 0.04 to 3.5 days under aerobic conditions to between 55 and 103 days under anaerobic conditions. Biodegradation rates for pyridine range from a half-life of 0.4 to 9 days under aerobic conditions to approximately 25 days under anaerobic conditions. Biodegradation rates for picoline range from 2 to 30 days for complete degradation under aerobic conditions to greater than 200 days under anaerobic conditions. (Reference: <http://toxnet.nlm.nih.gov/cgi-bin/sis/htmlgen?HSDB> , August 24, 2007. United States National Library of Medicine, Toxicology Data Network.)

Conditions in the groundwater environment are less conducive to biodegradation than the laboratory ideal. Under groundwater temperature and electron acceptor and donor conditions at a site, the actual biodegradation rates can be substantially slower than in the laboratory. However, compared with many other synthetic industrial compounds

found in the soil and groundwater environment at other sites, the Harriman site COCs are able to biodegrade relatively easily and rapidly.

The compounds of concern at this site are biodegradable under all conditions, which indicate that they are favorable for treatment via enhanced bioremediation or natural bioremediation (also referred to herein as natural attenuation). The Trust demonstrated significant aerobic biodegradation of the compounds of concern in soils based on the results of the "Respirometric Testing and Soil Column Testing" conducted late 1996 – early 1997 for the Maybrook Lagoon Site located in Hamptonburgh, NY (CRA, 1997).

Under certain circumstances, biodegradation of some compounds will generate a more toxic reaction endproduct than the initial compound. Because site COCs are not halogenated (do not contain chlorine, bromine, or fluorine), the endproducts are innocuous. The primary biodegradation endproducts are carbon dioxide, methane, hydrogen sulfide, ferrous iron, manganese (II), nitrogen, ammonia, and water. Benzene (C₆H₆) reactions with the common aquifer electron acceptor compounds and resultant reaction endproducts are presented below.

Electron Acceptor	Reaction
Oxygen (O ₂)	$C_6H_6 + 7.5 O_2 \rightarrow 6 CO_2 + 3 H_2O$
Nitrate (NO ₃)	$C_6H_6 + 6 NO_3^- + H^+ \rightarrow 6 CO_2 + 3 N_2 + 6 H_2O$
Manganese (Mn ⁺⁴)	$C_6H_6 + 15 Mn^{+4} + 12 H_2O \rightarrow 6 CO_2 + 15 Mn^{+2} + 30 H^+$
Iron (Fe ⁺³)	$C_6H_6 + 30 Fe^{+3} + 12 H_2O \rightarrow 6 CO_2 + 30 Fe^{+2} + 30 H^+$
Sulfate (SO ₄)	$C_6H_6 + 3.75 SO_4^{-2} + 7.5 H^+ \rightarrow 6 CO_2 + 3.75 H_2S + 3 H_2O$
Carbon Dioxide (CO ₂)	$C_6H_6 + 4.5 H_2O \rightarrow 2.25 CO_2 + 3.75 CH_4$

4.3 Biosparge System

A biosparge pilot test program was implemented in November 2000. Data obtained after two months of operation documented the ability of the single pilot test biosparge well to influence groundwater quality conditions (dissolved oxygen and redox potential) and benzene concentrations at monitoring wells points proximate to the sparge point. The results were reported in the Interim Pilot Study Report submitted to the NYSDEC in March 2001. Based on the pilot program success, design drawings for a full-scale system of 20 biosparge wells arrayed in three areas of the eastern portion of the facility were prepared and submitted to the NYSDEC in September 2001.

The full scale bioremediation system was installed in the overburden aquifer and began operations in December 2001. Compressed air is conveyed to a series of twenty injection (sparge) wells located within the groundwater plume (see Figure 2-2 for system locations). The compressed air exits the slotted well screen at the base of the sparge well. Oxygen in the compressed air partitions into groundwater as the injected gas migrates vertically and horizontally through the aquifer. The oxygen addition supports aerobic bioremediation of the compounds of concern.

Compressed air injection wells are also used for air sparge remediation systems that can be applied at sites with conditions differing from those at the Nepera site. In air sparge systems, the oxygen in the compressed air can vertically migrate towards the ground surface and support aerobic bioremediation and volatilization in both the saturated and unsaturated zone. Due to the clayey-silt aquitard overlying the overburden aquifer at the Nepera site, the compressed air/oxygen is confined to the saturated overburden aquifer where bioremediation, but not volatilization, can occur. At the Nepera site, conditions are such that the biosparge system was designed to only address the overburden aquifer.

4.4 Natural Attenuation

Though the biosparge system is providing beneficial oxygen to the aquifer, it is believed that much of the benzene (and other COCs) attenuation is attributable to natural processes. The biosparge system is just one source of electron acceptors that support biological uptake and transformation of benzene. Electron acceptors, (primarily oxygen) are continuously being added to the impacted aquifer system naturally through infiltration of rainfall and snowmelt and influent groundwater flow from upgradient areas. The natural mass flux of these electron acceptors into the system is

likely much greater than that added artificially by the biosparge system. The U.S. Environmental Protection Agency describes monitored natural attenuation (MNA) as the reliance on natural attenuation processes (within the context of a carefully controlled and monitored site cleanup approach) to achieve site-specific remediation objectives within a time frame that is reasonable compared to that offered by other more active methods. The "natural attenuation processes" that are at work in such a remediation approach include a variety of physical, chemical, or biological processes that, under favorable conditions, act without human intervention to reduce the mass, toxicity, mobility, volume, or concentration of contaminants in soil or groundwater. These in-situ processes include biodegradation; dispersion; dilution; sorption; volatilization; and chemical or biological stabilization, transformation, or destruction of contaminants.

Two main lines of evidence are used to demonstrate that natural attenuation of an electron donor compound is occurring at an impacted site: 1) contaminant groundwater concentrations in monitoring wells are stable or decreasing and 2) electron acceptors compound concentrations are depressed as compared to background concentrations.

4.5 Groundwater Contaminant Concentration Trend Analysis

As part of the January 2007 report, ARCADIS provided Figure 8-2, Groundwater Quality Trends for Select Monitoring Well. The figure provided graphical bar charts of concentrations for eight monitoring wells and is reproduced herein as Figure 4-1. Stable or decreasing contaminant groundwater concentrations in site monitoring wells are the first and primary line of evidence for enhanced (biosparge) and/or natural attenuation as an adequate site remedy. Stable or decreasing trends would demonstrate that the natural attenuation mechanisms (augmented by biosparge-supplied oxygen) within the aquifer are preventing further plume migration and that the overall contaminant mass is decreasing. With stable or decreasing trends, biosparge and MNA would be demonstrated to be protective of potential downgradient receptors and result in restoration of the aquifer over time.

The New York Department of Environmental Conservation discusses the primary line of evidence for MNA in their Draft DER-10 Technical Guidance for Site Investigation and Remediation:

- i. The determination that MNA has completely remediated the site in a manner that is fully protective of all identified sensitive receptors and that monitoring can be terminated, is defined as follows:
- ii. The contaminant plume length has been demonstrated to be stable or shrinking by sufficient and suitable groundwater monitoring. This requires concentration versus distance trend analysis, with suitable statistical validation, with the test applied to each individual contaminant detected in each monitoring well; and,
- iii. The contaminant concentrations along the centerline of the plume have been demonstrated to be decreasing by sufficient and suitable groundwater monitoring. This requires concentration versus time trend analysis, with suitable statistical validation, with the test applied to each individual contaminant detected in each monitoring well and a demonstration that groundwater standards are met before reaching the compliance point identified in the decision document.

Due to operation of the biosparge system, the groundwater system is not currently under natural attenuation conditions. However, as it is believed that much of impacts are currently being addressed through natural attenuation mechanisms, the stability analysis was carried out to assess the current plume status. If the plume is found to be stable or decreasing the current remedy is appropriate. If the plume is expanding additional remedial work may be necessary.

ARCADIS analyzed contaminant concentration data for nine site groundwater wells using the Mann-Kendall non-parametric statistical test. The Mann-Kendall statistical test is commonly used for natural attenuation evaluations. The Mann-Kendall test yields information on the contaminant concentration trends and gives the following results based on the statistical significance of the data: increasing, probably increasing, stable, probably decreasing, decreasing, or no trend. Additional information on the Mann-Kendall test and the statistical significance of the results are provided in Appendix C. A summary table is provided on the first page of the Appendix.

Data from site monitoring wells from September 2004 to date were used in the trend analyses. These data were used because they coincide with the shut down of the historical IRM pumping system and represent current conditions. Note that trend analyses were only performed for wells that had been sampled four or more times since September 2004. As a consequence, trend analysis is not yet performed for MW-1S, RW-1R or MW-5S. (Note: Mann-Kendall analyses require four or more

samples to be statistically valid [Wiedemeier, Todd H., Hanadi S. Rafai, Charles J. Newell, and John T. Wilson. 1999. *Natural Attenuation of Fuels and Solvents in the Subsurface*. John Wiley and Son, Inc., New York]).

The trend analyses in Appendix C and summarized on the first page of the appendix show that benzene concentrations are decreasing or stable for two overburden aquifer plume wells – MW-16S and MW-53D - respectively. Benzene concentrations in plume fringe well MW-8S are also decreasing. The results for five overburden aquifer plume wells – MW-20S, MW-25S, MW-33, OW-7 and OW-6 – indicate no trend for benzene. This is due to the relatively few samples available to be used for the analyses (5 or 6) along with the fairly large variability in the concentrations reported in those samples. It is anticipated that as the data sets for each well increases with time, a trend will be able to be resolved.

As noted in recent quarterly progress reports submitted to the NYSDEC, a 2007 assessment of biosparge wells BS-1 through BS-4, situated immediately upgradient from monitoring wells OR-6, OR-7 and MW-25S, established that these sparge wells had broken fittings, choked screens or both. As a consequence, biosparge system oxygen was not being effectively delivered to the area of these three monitoring wells. One sparge well was repaired and the other three were replaced. The analytical results for the October 2007 semi-annual sampling event will allow for a better assessment of the recent effectiveness of the biosparge system in this area. Please note that groundwater quality in overburden monitoring well MW-12S, which is approximately 300 feet downgradient from the three aforementioned wells, met or equaled SCGs in June 2006 and January 2007.

One well in the bedrock aquifer, MW-20D, showed an increasing benzene trend. The increase in concentration from 67 ug/L to 110 ug/L is below the November 2000 historic high benzene concentration in this well of 230 ug/L. MW-20D may not accurately reflect bedrock groundwater quality. A program that will be implemented to better evaluate bedrock groundwater quality is described in Section 7 herein.

Similar trends were observed for pyridine and alpha-picoline. Contaminant concentrations are stable in most wells for which a trend could be established. An increasing trend was observed in MW-16S and a probably increasing trend in MW-53D. Alpha-picoline concentrations increased from 72 to 230 ug/L in MW-16S over the period, but were below the historic high in that well of 250 ug/L observed in 2000. Alpha-picoline increased from 3 to 5 ug/L in MW-53D, which is below the groundwater criterion established for this compound.

Additional data from future sampling intervals will increase the statistical significance of the evaluation. These additional data may resolve true trends for wells that had a no trend result and provide sufficient data to perform trend analyses on MW-1S, RW-1R and other wells.

4.6 Electron Acceptor Concentrations

ARCADIS evaluated groundwater geochemical data within the plume footprints to determine if biological activity associated with contaminant biodegradation is occurring within the plume. As discussed above, chemical releases to the environment often stimulate increased bacterial growth as the released chemical(s) is more readily available for consumption as compared to other food sources in the aquifer.

Evidence for increased aerobic microbial activity can be found by comparing the concentrations of common electron acceptors to background aquifer levels. Lower electron acceptor concentrations than the background levels are indicative of increased biological activity within that portion of the aquifer. In some instances, electron acceptor reaction endproducts are observed rather than the initial substrate. This is done when the electron acceptor is insoluble (ferric iron and manganese [IV]) or so abundant (carbon dioxide) that it cannot be accurately quantified directly. In the case where electron acceptor endproducts are observed, a higher concentration of endproducts is indicative of increased microbial activity. The electron acceptor compounds and reaction endproducts that were evaluated were:

Electron Acceptor	Directly Observed	Reaction Endproduct Observed	Reaction Endproduct
Oxygen	X		--
Nitrate	X		--
Manganese (IV)		X	Manganese (II)
Ferric Iron		X	Ferrous Iron
Sulfate	X		--
Carbon Dioxide		X	Methane

The geochemical analysis results are presented on Tables 4-1 and 4-2. The November 2000 groundwater quality data clearly show that the plume area is biologically active as compared to background (upgradient) areas. Average dissolved oxygen and sulfate concentrations in overburden aquifer plume wells are lower than those in the background wells. For example, electron acceptor sulfate concentrations in overburden aquifer upgradient monitoring wells PZ-1 and PZ-2 were 25.6 and 43.1 mg/L, respectively. Sulfate concentrations in plume source area wells OW-6, OW-7,

and MW-16S were 1.24 ug/L, 1.62 ug/L and <1.0 ug/L, respectively. The substantially lower sulfate concentrations in the plume source area wells are indicative of the increased microbial activity. Manganese(II) and ferrous iron concentrations are elevated in plume wells OW-6, OW-7 and MW-16S compared to upgradient wells PZ-1 and PZ-2, establishing the generation of manganese and iron endproducts through microbial activity. The presence of elevated methane concentrations in the plume wells further documents this activity. The June 2006 data show similar groundwater quality in the plume area (i.e., high ferrous iron and manganese (II) concentrations) but can not be contrasted with time-coincident upgradient monitoring well concentrations as the upgradient monitoring wells were not sampled for these parameters during the sampling event.

The depressed sulfate concentrations, relatively elevated ferrous iron, manganese II and methane concentrations in the overburden aquifer all indicate extensive biological activity in plume groundwater even prior to the initiation of the biosparge program. Similar data from 2006 indicate that biological activity remains high.

5. Plume Fringe and Sentinel Monitoring Wells Program and ROD-mandated Groundwater Quality Management Program

The January 2007 report (Section 11) refers to the Site perimeter (property line) as the project point of compliance. The report did not provide the basis for the linkage of the site perimeter and the project point of compliance. Nor did the report relate the point of compliance to the plume fringe monitoring well and sentinel well terminology provided in draft DER-10.

The 1997 Record of Decision (ROD) does not use the term point of compliance. The selected remedy includes the design and implementation program to contain the groundwater plume on site and the requirement for institutional controls, including a deed restriction to restrict the use of groundwater beneath the property and the installation of additional sentry ("sentinel") wells between the site and existing or future public drinking water supplies to be monitored as part of a long-term monitoring program. The ROD (Section 6.1) makes reference to the evaluation of remedial alternatives in the Feasibility Study. Section 2.2.3 (p. 50) of the Feasibility Study states the following:

"The groundwater ARARS (standards, criteria, guidance [SCGs]), presented previously in Table 2.1, can be used as potential groundwater cleanup goals. It is noted that since the Site use will remain the same in the future, these cleanup

goals are appropriately applied at a point of compliance considered to be the Site (i.e., property) boundary.”

As described in Section 1.2 herein, Draft DER-10 describes two types of wells used to confirm plume effectiveness monitoring (PEM) and monitored natural attenuation (MNA) monitoring: plume fringe monitoring wells that monitor the area just beyond the downgradient edge of the plume where contaminant concentrations are below applicable SCGs and sentinel wells located no closer than three years travel time of groundwater to the nearest potential groundwater receptor and no further than two years' travel time from the delineated down-gradient extent of the contaminant plume.

For consistency with current NYSDEC terminology, the term 'point of compliance well' will be discarded; the terms 'plume fringe well' and 'sentinel well' will be used. As of September 2007, the following existing overburden aquifer groundwater monitoring wells are proposed as plume fringe and sentinel wells:

Plume Fringe Monitoring Wells: MW-1S, MW-11S, MW-8S, RW-1R, MW-12S

Sentinel Monitoring Wells: MW-24S, MW-7S, MW-5S, MW-4S

Due to the limited extent of bedrock groundwater impacts, bedrock wells MW-23D, MW-26D and MW-6D are proposed to serve as both plume fringe and sentinel wells.

A program to supplement these existing plume fringe and sentinel wells is provided in Sections 6 of this supplemental report. The nearby water supply wells and associated monitoring are discussed in Section 7.

6. Spatial and Temporal Coverage and Gaps in the Overburden Aquifer Groundwater Monitoring Program

The January 2007 report provides a summary of groundwater quality conditions at the Nepera site. During the March 2007 meeting, the adequacy of the current overburden and bedrock aquifer groundwater monitoring well networks was discussed. The purposes and adequacy of these networks are described and discussed in Sections 6 and 7 below and recommendations are presented.

6.1 Existing Monitoring Wells

Since 1985, 54 groundwater monitoring wells have been installed on site for a variety of investigation, assessment and remediation purposes. Wells are screened in the shallow perched water-bearing zone, fill, the overburden aquitard, the underlying overburden aquifer and the bedrock aquifer. Table 6-1 (Table 5-1 from the January 2007 report) provides information on each well, including installation rationale. Well locations are shown in Figure 2-2. Logs of all wells are provided in Appendix D. The purposes for which wells were installed include:

- Monitor site perimeter (to be referred to herein for circa 2007 conditions as plume fringe and sentinel monitoring wells) groundwater quality (MW-1S through MW13S)
- Investigate groundwater quality in specific areas known or suspected to be contaminated
- Investigate groundwater quality upgradient from specific known areas of groundwater contamination
- Obtain geologic and hydrogeologic information
- Establish hydraulic gradient and groundwater flow direction
- IRM groundwater pumping wells
- Evaluate the hydraulic relationship between groundwater and the West Branch Ramapo River
- Streambank erosion evaluation
- Observation wells for biosparge pilot test

Thirty of these wells are screened in the overburden aquifer. Ten wells are screened or open in the bedrock aquifer. Fourteen wells are screened either in the overburden aquitard, a perched zone above the aquitard, or in a shallow aquifer isolated from the overburden aquifer by the overburden aquitard. Information on each well is provided in Table 6-1. Twenty-one wells have been sampled as part of the routine semi-annual

groundwater quality monitoring program. Eighteen wells are sampled for benzene, toluene, ethylbenzene, xylenes (BTEX), chlorobenzene, pyridine, alpha-picoline, and 2-amino-pyridine. Water levels are measured semi-annually in all site monitoring wells.

6.2 Source Area Wells

No groundwater monitoring wells were installed within an extended area of the former chemical storage and process area bounded by monitoring wells MW-21S, PZ-1, OW-6, MW-25S, MW-16S, MW-53D, and MW-33. Test pit soils data and soil gas survey data obtained in 1991 and reported in the RI (see Figures 6-1 herein, developed using RI figures 6.2 and 6.3) indicate that elevated concentrations of VOCs and SVOCs were detected above the clay aquitard at several locations for which no monitoring wells have been established in the immediate area. Source area/plume body overburden aquifer monitoring wells OW-6, OW-7, MW-25S, MW-16S, MW-53D, MW-33, and MW-20S each monitor groundwater that has its origin in this area.

Nearly all or all of the unmonitored area is underlain by the clayey-silt aquitard. As a consequence, it is not certain that COCs detected above or near the top of the clay (from the aforementioned test pits and soil gas samples) have migrated to the overburden aquifer beneath the aquitard. Data from within and immediately below the aquitard at a location 120 feet northwest of monitoring well OW-6 were obtained in October 2006 from the limited Geoprobe boring program (see Section 3.1). Based on the October 2006 findings, it is probable (but not certain) that COCs within the aquitard serve as a continuing diffusive source of benzene to the overburden aquifer. Consequently, there is a reasonable possibility that one or more of the areas identified in the 1991 test pit and soil gas surveys may continue to serve as a continuing source of COCs to the overburden aquifer.

Similarly, outside of the area described above, there are no monitoring wells immediately adjacent to Test Pits TP-4 and TP-7, both of which reported elevated concentrations of VOCs.

6.3 Plume Lateral Extent Wells

Plumes A, B and C have been depicted as independent plumes since the outset of the remediation program. Dashed lines bounding the lateral limits of each plume have been used to indicate that the limits are estimated. Plume widths may actually be narrower or wider than the widths depicted in the plume maps. Four monitoring wells – MW-2S, MW-11S, PZ-2, and MW-36S - serve in part to establish plume widths.

6.4 Plume Fringe and Sentinel Wells

Six overburden aquifer monitoring wells - MW-3S, MW-4S, MW-5S, MW-27S, MW-7S and MW-24S - are situated at or immediately downgradient from the site's perimeter property line and serve as sentinel wells. Seven other overburden aquifer monitoring wells – MW-12S, MW-13S, RW-1R, MW-8S, MW-1S, MW-36S and MW-35S– are situated downgradient from the plume area and upgradient from the perimeter and serve as plume fringe monitoring wells.

As part of the semi-annual groundwater monitoring program, five of these 13 wells have been sampled on an at least semi-annual basis since prior to 2000. For those wells not included in the long-term semi-annual program, three were most recently sampled in 2006 or 2007 after a several year interval. Two wells were installed in 2003 and have been sampled once and twice, respectively, and three wells have not been sampled since 1999 or 2000.

6.5 Proposed Enhanced Plume Management Monitoring Well Program

A three-phased program to more fully understand soil and groundwater conditions within the potential source area and to enhance the plume body, plume fringe and sentinel groundwater monitoring program is presented below for the NYSDEC's consideration.

Phase 1 - Continuous core Geoprobe sampling will be performed in the vicinity of seven identified potential groundwater contamination source areas not already monitored at the site. In addition, the western edge of the aquitard will be more fully identified and a possible preferential pathway through the aquitard will be surveyed (Figure 6-1). Four to six borings are anticipated at each of the seven locations. One soil and one groundwater sample will be collected from each boring for laboratory analysis. PID readings will be used to supplement the soils analytical data.

The Geoprobe survey will provide the following information:

- Vertical and horizontal extent of the residual source in the predominantly silty beds (aka overburden aquitard) overlying the overburden aquifer.
- Thickness of (and in places documentation of the margin of or absence of) the aquitard in the potential source areas.

- Qualitative identification of the headward extent of contaminated groundwater in the potential source area
- Determination of the presence or absence of a narrow and shallow preferential groundwater flow pathway extending northeast from the vicinity of PZ-1.

Phase 2 - Installation of overburden groundwater monitoring wells in the potential source areas as identified in Phase 1. Source area monitoring well locations will be developed using geologic, geochemical and COC data obtained in Phase 1. Monitoring wells to more fully characterize the lateral extent of the plumes will also be installed as part of the Phase 2 program based on Phase 1 findings.

If the NYSDEC will allow selected biosparge wells to be turned off for a two month period, selected sparge wells will be sampled as overburden plume and or fringe wells. Alternately, a monitoring well will be installed and sampled upgradient from BS-16 in line with monitoring well RW-1R.

All new groundwater monitoring wells will be sampled and analyzed for benzene/toluene/ethylbenzene, and xylenes (BTEX), SVOCs, and selected additional parameters.

Phase 3 – Based on Phase 2 results, additional plume fringe and sentinel monitoring well locations will be selected and the wells will be installed and sampled.

An OM&M plan providing the post-Phase 3 long-term monitoring program will be drafted and submitted to the NYSDEC for review and approval following the Phase 3 sampling and analysis program.

7. Spatial and Temporal Coverage and Gaps in the Bedrock Aquifer Groundwater Monitoring Program and Relationship to Town of Harriman Water Supply Wells

7.1 Existing Monitoring Wells

Ten Site bedrock groundwater monitoring wells are screened or are open within the bedrock aquifer. Of these, three are along the upgradient property line (R-2D, MW-21D, and MW-10D), three are in areas that underlie overburden aquifer plumes (MW-25D, MW-18D, MW-20D), and four are at or downgradient from the site perimeter (MW-23D, MW-26D, MW-6D, and MW-27D). Of the seven wells within the area of the

overburden plumes or along the site perimeter, three have been a part of the semi-annual groundwater monitoring program during the 2000-2007 period, three have not been sampled since 2000, and one has not been sampled since 1991.

Two of the four site perimeter bedrock groundwater monitoring wells are routinely sampled (MW-6D and MW-26D). The other two (MW-23D and MW-27D) have not been sampled since 2000. Only one of the four perimeter bedrock groundwater monitoring wells has recorded a COC concentration exceeding SCGs – MW-6D (one in 20 samples had a benzene concentration at 5 ug/L in 2004)

Of the three bedrock monitoring wells underlying the area of the overburden aquifer plumes, two wells (MW-25D and MW-18D) have not been sampled since 2000 and 1991, respectively. The only SCG exceeded in these wells was benzene, at maximum concentrations of 25 ug/L and 15 ug/L, orders of magnitude lower in concentration than that detected in the nearby overburden aquifer monitoring wells MW-16S and MW-25S. MW-20D routinely exceeds SCGs for benzene, toluene, pyridine, alpha-picoline and 2-amino-pyridine.

7.2 Public Water Supply Well Pump Rate Test

The January 2007 report provided information on the Village of Harriman water supply wells. Supply well OR-7 is a 417-foot deep bedrock well situated 3500 feet east of the Site. The January 2007 report referenced correspondence from the Village's consultant to the NYSDEC and provided a review of groundwater quality data collected by the consultant for the years 2000-2006 to document the absence of impact or potential impact to the supply well from the Site.

In the March meeting, this issue of bedrock impacts and potential impacts to public water supply were brought up in discussion. Information available in a report prepared by the Town's consultant (Increased Pumping Rate Test Analysis Well OR-7 Village of Harriman, OBG, July 1998) is summarized below. The 1998 report is provided in Appendix F herein.

In 1998, a pumping test was performed to evaluate whether OR-7 could be pumped at a sustained yield of 148 gallons per minute so as to establish a basis for increasing the permitted water taking from 50 to 125 gpm. During the 72-hour pumping test, water levels in a monitoring network of four well clusters (paired overburden aquifer and bedrock aquifer monitoring wells) were recorded to establish whether the pumping would significantly affect water levels in monitoring wells close to the Site and whether

there was a direct connection between the overburden aquifer and the bedrock aquifer. Drawdown in two bedrock wells 1,500 feet and 1,200 feet west of OR-7 was observed. No drawdown attributed to the pumping was observed in Site sentinel bedrock monitoring wells MW-6D or MW-23D. None of the overburden monitoring wells monitored for the test showed any drawdown attributed to the pumping test, leading to the consultant's conclusion that the data strongly indicate no direct hydraulic connection between the overburden aquifer and the significant water-bearing zone encountered in the bedrock aquifer.

Please note that during the March meeting, an NYSDEC representative provided a recollection that drawdown during this pumping test in a Site monitoring well was about 12 feet. Based on review of the pumping test consultant's report, the drawdown was associated with offsite bedrock monitoring well D-4, which had 12.4 feet of drawdown. D-4 is approximately 850 feet southeast of the closest point of Nepera site property boundary. Also, a concern was mentioned that because the request for an increased OR-7 pumping rate was only 125 gpm, not 148 gpm, this implied that pumping 148 gpm would cause a negative impact at OR-7 associated with the Nepera Site. The pumping test results demonstrate that even with the full 148 gpm pumped during the test, no hydraulic connection was observed.

7.3 MW-20D

As discussed in Section 7.1, the only bedrock monitoring well with elevated COC concentrations is MW-20D. Review of the MW-20D boring and monitoring well details (Appendix D) indicates that MW-20D was drilled to a depth of approximately 65 feet, five feet below the overburden/bedrock interface. A four-inch PVC casing was grouted within an eight-inch bore hole. A 3 7/8" bore hole was then drilled to a depth of about 85 feet and the well was completed as an open borehole without a well screen and sand pack. The well log indicates that the dolomite bedrock is fresh to moderately weathered (along a fracture).

There is reason to suspect that samples obtained from MW-20D may not represent actual bedrock groundwater quality conditions beneath the site. The well casing to prohibit interference from the overburden aquifer groundwater extends only five feet below the overburden/bedrock interface. The shallow bedrock may be weathered in places, and may afford the opportunity for groundwater from the overburden aquifer to intermingle with groundwater in the weathered bedrock. Another reason to question the representativeness of data from this well is that water levels in this well are at

times extraordinarily high (see data in Appendix B) compared to other bedrock wells and appear to be influenced from leakage around the well seal.

7.4 Summary of Bedrock Groundwater

As stated in the ROD (p. 5), contamination in the bedrock is essentially confined to the source area represented by bedrock monitoring well MW-20D. As indicated in Section 7.2, there is reason to suspect that data from MW-20D may not be representative of bedrock groundwater quality conditions. With the single data point exception noted, the groundwater quality in the two sentinel bedrock monitoring wells that have been routinely sampled meets SCGs. There is no threat posed to the nearby public supply well.

7.5 Proposed Monitoring

As discussed in Section 5, the terms for wells formerly referred to as perimeter or point of compliance wells will be referred to as plume fringe or sentinel wells as appropriate. Due to the limited extent of bedrock groundwater impacts, bedrock wells MW-23D, MW-26D and MW-6D are proposed to serve as both plume fringe and sentinel wells.

A new well, preliminarily identified as MWB-20-70, will be established adjacent to MW-20D. It will be drilled and cased to a minimum of 10 feet into competent (unweathered) bedrock. A 15-foot (or less) open rock well will be drilled and established below the bottom of the casing from 70-85 feet below the surface. Bedrock monitoring wells MW-20D and MWB-20-70 will be sampled and analyzed for VOCs and site-specific SVOCs. Results and recommendations for future sampling and analyses will be presented to the NYSDEC.

Should source area bedrock monitoring wells MW-25D and MW-18D and plume fringe/sentinel bedrock monitoring wells MW-27D and MW-23D (none of which have been sampled since 2000) still be accessible for sampling, a single round of sampling and analyses for VOCs and site-specific SVOCs will take place as part of the next semi-annual sampling event. Following reporting and review of the resulting groundwater analytical data, an updated, routine groundwater monitoring program will be submitted to the NYSDEC as part of the updated OM&M plan.

8. Support for ARCADIS' Proposal to Substantially Reduce the Testing of Pyridine and Related Semi-volatile Organic Compounds

Since 2000, routine groundwater quality sampling and analysis for nearly all wells monitored has included analyses of site VOCs and the SVOCs pyridine, alpha-picoline, and 2-amino-pyridine. In the proposed Groundwater Monitoring Program included as Appendix C of the January 2007 report, ARCADIS proposed the following monitoring program change with respect to SVOC analyses:

- The site-specific semi-volatile compounds – pyridine, alpha-picoline, and 2-amino-pyridine – are detected at concentrations lower than benzene and increase and decrease in a consistent pattern as benzene. As a consequence, it was proposed that analysis of semi-volatiles be limited to MW-16S and MW-20S one time per year.

During the course of the March 2007 meeting, NYSDEC representatives requested that ARCADIS provide more information to support this request.

Review of historic groundwater quality data (Figure 3-2 and Appendix B) shows that one or more of the three SVOC compounds are routinely detected at concentrations exceeding the 50 ug/L SCG for each compound in six overburden aquifer or bedrock monitoring wells - MW-16S, OR-7, OR-6, MW-25S, MW-20S and MW-20D - all of which are well within the plumes. Historically, these compounds have been only rarely detected in wells currently proposed for designation as plume fringe or sentinel monitoring wells, and when detected have been well below the SCGs.

Plots of benzene and site SVOC concentrations over time in three of the monitoring wells having elevated SVOC concentrations – MW16S, MW-20S and OW-6 - are provided in Appendix E. With the exception of alpha-picoline in MW-16S during the period since June 2003, the SVOC concentration fluctuations closely match the benzene concentration fluctuations over time. For example in OW-6S, the highest alpha-picoline concentration recorded occurred in the same sample as the highest benzene concentration. Lesser peaks also matched. Similar matches are illustrated in MW-16S (1999-2003) and MW-20S.

As described in Section 3.1, pyridine and alpha-picoline both biodegrade in groundwater. SCGs for these compounds (50 ug/L) have continuously been met at the wells currently proposed as plume fringe and sentinel monitoring wells. Concentration

fluctuations in plume centerline wells with elevated SVOC concentrations generally mimic those for benzene.

As a consequence, the SVOC data provide no unique useful information and are superfluous for the monitoring of the plume fringe and sentinel well locations and the improvements in groundwater quality within the body of the plumes. Consequently, it is proposed that SVOC testing be limited to MW-16S and MW-20S on a once a year basis.

ROD Alternative 2, Institutional Controls, includes the requirement that groundwater samples be analyzed for SVOCs and pyridines. As a consequence, in the preliminary draft ESD, the following element has been included in Section 3.1, Modifications to the ROD Components:

- The analytical requirements will be modified (from the Institutional Controls portion of the ROD remedy) to, "samples will be analyzed for VOCs. SVOCs and pyridines will be analyzed on a limited basis as to be provided in the OM&M Plan."

9. MW-1S Historical Data

The MW-1S historical influent groundwater quality data, with operational time-line information as requested in the March meeting, is provided in Figure 9-1. As was discussed during the March meeting, benzene concentrations in MW-1 have been in general decline since 1996. Comparison of the 2006-2007 results to the 10/2002-2/2003 results is particularly revealing in that during both periods the IRM well at MW-1 was off. In the 2002-2003 period, the benzene concentrations ranged between about 70 ug/L and 230 ug/L. During the 2006-2007 period benzene has been <1.0 ug/L. Consequently, it would appear that the absence of IRM pumping during 2006-2007 does not explain the groundwater quality improvement at MW-1S, as absence of pumping did not result in low concentrations in 2002-2003.

10. Summary of Findings and Conclusions

In the 20 years since benzene and other site compounds of concern were identified at the Nepera site, considerable investigatory and remediation work has been performed. Drum and soil excavation was performed in 1987 and 1999. Using an alternative remedial approach to the groundwater pump-and-treat system specified in the ROD, biosparge and natural attenuation were jointly used with the IRM pump and treat system until September 2004 to contain and treat contaminated groundwater. Since

discontinuing the IRM pump-and-treat system operations, the biosparge system and natural attenuation have operated as stand alone systems. As evidenced in the recent (2006-2007) analyses from site groundwater monitoring wells, the remediation program is meeting with success; plumes are contained and have diminished in concentration and extent (by 75 per cent) since 1988 and groundwater quality in the plume fringe and sentinel wells meets current NYSDEC standards. Findings and conclusions to date are summarized below:

1. Based on the data available from the existing overburden aquifer monitoring wells, the area of the site underlain by the plume in 2007 (including the inferred area shown in Figure 2-1) is approximately six acres or 25 percent of the 1988 plume area, a 75 percent reduction in area.
2. Based on the information obtained as part of the limited testing performed in October 2006, it is evident that benzene is present in at least one portion of the overburden aquitard (clayey silt). The data obtained from these borings indicate that the source area for the impacted groundwater observed in monitoring well OW-6 may be 120 or more feet west and upgradient from OW-6 and sparge Line A.
3. In June 2006 and January 2007, groundwater quality in Site's existing plume fringe and sentinel monitoring wells within the overburden aquifer met NYSDEC standards, criteria and goals (SCGs) established for Site groundwater contaminants of concern.
4. Since the IRM well pumping was discontinued in September 2004, COC SCGs for Plumes A and B in the overburden aquifer have been met in the plume fringe and sentinel monitoring wells immediately downgradient from the biosparge system and 500 feet upgradient from the site perimeter. Groundwater quality data trend analyses since that time support that COC concentrations in groundwater have been generally stable or declining during this period, although trends in some wells can not be properly established until more monitoring data are obtained.
5. In June 2006 and January 2007, natural attenuation has achieved SCGs for Plume C COCs at the plume fringe/sentinel well MW-1S.
6. Groundwater contamination source area removal - the excavation of drums and contaminated soil and ORC treatment at Area F and Building 53 and earlier excavation in the area of MW-16S - has contributed to the groundwater quality improvements. Since the 1980s, facility capital improvements (e.g., tank containment) and improved

operating procedures, and more recently termination of chemical process and storage operations, have provided source control so that preexisting groundwater plumes would not be replenished or new plumes created.

7. Since 2004, plume fringe and sentinel wells have achieved the COC SCGs downgradient from Plumes A and B in the absence of an active IRM pump and treat system and with the presence of active biosparge and natural, in-situ biological systems. The continued success of the biosparge and natural biological systems will be monitored semi-annual using the existing and soon to be installed enhanced groundwater monitoring program wells. Restarting IRM pumping from RW-1R is unnecessary and would provide no groundwater quality benefit not already being achieved by the biosparge and natural biological systems.

8. Since 2006, groundwater quality at MW-1S, which is downgradient from Plume C, has met COC SCGs in the absence of an active IRM pump and treat system. The continued success of natural, in-situ biological systems will be monitored semi-annually using existing and soon to be installed enhanced groundwater monitoring program wells. Restarting IRM pumping from MW-1S is unnecessary and would provide no groundwater quality benefit not already being achieved by the natural biological system activity.

9. In the bedrock aquifer, COC concentrations exceeding SCGs are limited to a single monitoring well (MW-20D) near the center of the former processing area. Bedrock aquifer plume fringe and sentinel monitoring wells met SCGs in 2000 and 2006. An additional, bedrock monitoring well will be established adjacent to MW-20D, with a greater separation from the sediment/bedrock interface, to establish whether the groundwater quality data from MW-20D are representative of bedrock groundwater quality.

10. Village of Harriman water supply wells are not impacted by site groundwater. There are no plumes of COCs at or near the site perimeter that will impact Village of Harriman water supply wells in the future.

11. With respect to the Record of Decision, the goal to protect public and private drinking water supplies in the vicinity of the site is being met. A remedial action to design and implement a groundwater remediation program to contain the groundwater plume has been in place since December 2001. This remedial action achieves the above-stated goal, although by means other than that specified in the ROD.

12. For a large portion of the Site's former chemical storage and process area, there are limited groundwater monitoring wells and limited groundwater quality data. The lateral dimensions of plumes A, B and C are not well delineated due to the limited number of wells along the plume flanks. In the plume fringe and sentinels well zones, there are some wide gaps between monitoring locations. The Trust proposes a 3-phased program, described in Section 6.5, to fill these gaps.

13. Since the RI and FS were completed in 1995 and the ROD was published in 1997, new/updated guidance pertaining to inactive hazardous waste disposal sites/state Superfund Sites (Draft DER-10, Technical Guidance for Site Investigation and Remediation, 12/2002) have been published and are being utilized throughout the state. Draft DER-10 provides clear guidance on many things, most particularly with regard to guidance for remedial process closure and site closeout. With the NYSDEC's concurrence, the Trust and ARCADIS plan to utilize draft DER-10 for the remaining duration of the remediation and monitoring program.

11. Proposed Updated Remedial Approach

Albeit for a period limited to the three most recent semi-annual sampling events, the ROD goal of achieving SCGs at the plume fringe and sentinel monitoring wells was met in January and June 2006 and January 2007. Meeting SCGs for this still relatively short period of time is a major step to meeting the ROD goal with respect to active groundwater remediation. Presented in the subsections below, and based on review of the data acquired through January 2007 and the conclusions presented in Section 10, is the proposed project path forward.

11.1 Prepare and Put into Effect an Explanation of Significant Differences to Modify the ROD Remedy from Pump and Treat to Biosparge and Monitored Natural Attenuation

In accordance with NYSDEC Program ID: TAGM-4059, Making Changes to Selected Remedies, ARCADIS, on behalf of the Trust, submitted in January 2007 to the NYSDEC a preliminary draft Explanation of Significant Differences (ESD) to modify the ROD remedy element specifying the Alternative 7 Pump and Treat program as described in the ROD, to Biosparge and Monitored Natural Attenuation. Following the NYSDEC's review of this Supplemental Report, it is anticipated by the Trust that the NYSDEC will review the preliminary draft ESD and, after consensus is reached, will consult with the NYS Department of Health for their review and agreement. The ESD will then be issued to the public for review and comment. Please note that the

Trust/ARCADIS will provide the NYSDEC with an updated preliminary draft ESD in September 2007.

11.2 Continue Operation of Plumes A and B Biosparge Systems

Lines A through D of the biosparge system will continue to operate. From time to time individual sparge points may be temporarily shut down in order to be used for groundwater monitoring. After monitoring, they will be restored to service. The biosparge points that were not operational in March 2007 have been repaired or replaced. All 20 sparge wells are currently operating. Additional sparge points may be added to optimize the system.

Criteria to be used to determine when biosparge activities can be discontinued will be developed consistent with draft DER-10 guidance and provided as part of the Operations, Maintenance and Monitor (OM&M) Plan that will be submitted to the NYSDEC following issuance of the ESD.

11.3 Continue Plume C Monitored Natural Attenuation

Plume C has retreated in extent with unassisted natural bioremediation. Natural attenuation will continue to be monitored in plume body, plume fringe and sentinel wells associated with this plume.

Based on past monitoring activity, concentrations of benzene or other COCs above SCGs may appear from time to time at MW-1S. The OM&M Plan will address the response should a substantial and sustained increase in COC concentrations occur at MW-1S or within Plume C. In the event of a substantial and sustained increase in concentrations at MW-1S, an enhancement of the bioremediation program may be implemented.

11.4 Discontinue IRM

The IRM groundwater pumping and treatment systems, which were taken offline in 2004, will be discontinued. As described in this report, the goals established in the ROD to protect public and private drinking water supplies and containment of the plume have been met since the discontinuation of the IRM system. With respect to Plumes A and B, these goals are being met by the active biosparge system which began operation in December 2001 and which has operated since 2004 without IRM wells RW-1/RW-1R and R-3. With respect to Plume C, the goals are being met

by natural attenuation without IRM pumping at MW-1S. RW-1R and MW-1S are being added to the revised semi-annual groundwater monitoring program presented in Appendix G.

11.5 Add Bedrock Monitoring Well and Continue Bedrock Groundwater Quality Natural Attenuation Monitoring at MW-20D

MW-20D is the only substantially impacted bedrock groundwater monitoring well. As presented in Section 7 herein, an additional bedrock well, with a greater spacing between the overburden/bedrock interface and the well screen than used for MW-20D, will be installed adjacent to MW-20D to confirm the representiveness of the results historically obtained from MW-20D. Following review of the data obtained from the new well, a recommendation will be provided as to the future monitoring of bedrock groundwater quality in the vicinity of MW-20D.

11.6 Enhanced Groundwater Monitoring Well Program

A 3-Phase program, beginning with a Geoprobe boring program, will be performed in the potential source areas where limited groundwater monitoring wells and data are available. Monitoring wells to enhance monitoring of the plumes' source area(s), lateral dimensions and plume fringe and sentinel well areas will be installed and sampled as part of the second and third phases of the program. The program is summarized in Section 6.5.

11.7 Environmental Easement

In accordance with the ROD, the Maybrook and Harriman Trust, working through the site's current owner – Rutherford Chemical, Inc. – and the NYSDEC, will develop a legal instrument in the form of an environmental easement establishing a restriction on the use of groundwater beneath the property. Other elements of the deed restriction provision incorporated into the ROD, specifically related to restrictions on use of the property and a description of the remaining contamination on site, will be associated with a separate deed restriction not addressed as part of this groundwater report and program moving forward.

11.8 Well Decommissioning

Fifty-five groundwater monitoring wells have been established at the Harriman site since 1985. Of these wells, 30 are screened in the overburden aquifer, 14 are

screened in the perched unit/overburden aquitard, and 9 are screened (or open hole) in the bedrock. ARCADIS proposes to decommission 15 monitoring wells. Wells will be placed on the proposed decommissioning list for the following reasons:

- Bedrock well reporting non-detections or consistent, extremely low BTEX and pyridine concentrations
- Perched groundwater (above aquitard) with consistent BTEX and pyridine non-detects or consistent, extremely low concentrations
- Aquitard well reporting non-detections or consistent, extremely low BTEX and pyridine concentrations

Decommissioning procedures for the Harriman Site bedrock and shallow overburden monitoring wells will be conducted in accordance to the Groundwater Monitoring Well Decommissioning Procedures (NYSDEC, 2002). The Harriman Site Monitoring Well Decommissioning Plan will be submitted after the NYSDEC has reviewed this Supplemental Report.

11.9 Revised Groundwater Monitoring Program

The proposed Revised Groundwater Sampling and Analysis Program provided is an attachment to the January 2007 report has been slightly revised. The revised program provided herein will be considered an interim program until after the first round of groundwater quality data from the 3-Phase program proposed herein have been reviewed and assessed.

11.10 Operations, Maintenance, and Monitor (OM&M) Plan

Following publication of the ESD, ARCADIS will prepare an OM&M Plan for continued remediation system operations, groundwater monitoring, and reporting,

11.11 Criteria to Discontinue Plumes A and B Biosparge System

Criteria to discontinue the Plumes A and B Biosparge System will be developed in accordance with guidance provided in draft DER-10 and proposed as part of the OM&M Plan. Any potential contingencies will also be addressed.

11.12 Use of Draft DER-10 Guidance

Provisions of the Draft DER-10 guidance will be utilized for the remainder of the site remediation and monitoring program.



TABLES



Table 4-2 2000 Geochemical Water Quality Data, Groundwater Quality Assessment, Groundwater Remediation Progress and Proposed Updated Remediation Program Supplemental Report, Nepera Harriman Site, Harriman, NY, October 2007.

			Benzene (ug/L)	Dissolved Oxygen (mg/L)	Nitrate (mg/L)	Dissolved Manganese (ug/L)	Dissolved Iron (ug/L)	Sulfate (mg/L)	Methane (mg/L)	pH (S.U.)	Temperature (°C)
OVERBURDEN AQUIFER											
<i>Background (Upgradient) Wells</i>											
MW-2S	Nov-00	ND		0.5	0.672	31.6	<10.0	19.1	<0.07	7.3	18.6
MW-9S	Nov-00	ND		0.2	0.258	159	<10.0	26.8	<0.07	7.2	12.6
MW-21S	Nov-00	ND		1.3	1.09	7.0	<10.0	26.8	<0.07	7.4	17.3
AVERAGE	--	--		0.7	0.7	65.9	<10.0	24.2	<0.07	--	--
<i>Plume Wells</i>											
MW-1S	Nov-00	98		0.2	<0.10	992	1,610	72.3	2.13	7.4	13.8
MW-8S	Nov-00	510		0.0	<0.10	279	4,170	14.4	1.33	7.9	13.0
MW-16S	Nov-00	4,100		0.0	<0.10	575	4,930	<1.00	11.7	7.8	16.7
MW-20S	Nov-00	7.0		0.0	<0.10	158	456	34.4	4.44	8.2	17.1
MW-25S	Nov-00	2,300		3.2	<0.10	7	206	10.8	0.57	11.4	16.1
MW-53D	Nov-00	500		0.0	<0.10	650	4,100	1.74	1.54	7.7	14.6
OW-6	Nov-00	20,000		0.0	<0.10	983	4,250	1.24	11.8	7.6	13.7
OW-7	Nov-00	9,500		0.2	<0.10	7,540	16,700	1.62	5.8	7.1	13.2
RW-1S	Nov-00	84		0.2	<0.10	1,360	66.6	19.6	0.46	7.2	11.6
AVERAGE	--	--		0.4	<0.10	1,140	3,320	14.2	3.62	--	--
<i>Downgradient and Sidegradient Wells</i>											
MW-3S	Nov-00	ND		0.2	0.545	608	<10.0	29.5	<0.07	7.2	12.8
MW-4S	Nov-00	ND		1.3	<0.10	1,410	<10.0	32.8	<0.07	7.1	11.7
MW-5S	Nov-00	ND		0.2	<0.10	1,780	53.3	26.7	<0.07	7.3	14.2
MW-7S	Nov-00	0.4		0.2	<0.10	434	<10.0	36.2	<0.07	7.8	12.0
MW-11S	Nov-00	ND		0.0	0.103	483	240	25.9	0.11	7.5	15.4
MW-12S	Nov-00	2.0		0.0	<0.10	3,390	20,900	16.2	11.34	6.7	23.7
MW-24S	Nov-00	ND		0.0	<0.10	951	1420	888*	0.13	7.9	16.4
MW-27S	Nov-00	ND		0.6	0.114	<1.0	24.1	40	<0.07	12.2	12.1
PZ-2	Nov-00	ND		0.0	<0.10	439	1,440	43.1	<0.07	7.8	15.4
PZ-3	Nov-00	1.0		0.0	<0.10	1,460	1,960	127	0.07	8.4	15.4
AVERAGE	--	--		0.2	0.08	1,220	2,890	47	1.29	--	--

Table 4-2 2000 Geochemical Water Quality Data, Groundwater Quality Assessment, Groundwater Remediation Progress and Proposed Updated Remediation Program Supplemental Report, Nepera Harriman Site, Harriman, NY, October 2007.

			Benzene (ug/L)	Dissolved Oxygen (mg/L)	Nitrate (mg/L)	Dissolved Manganese (ug/L)	Dissolved Iron (ug/L)	Sulfate (mg/L)	Methane (mg/L)	pH (S.U.)	Temperature (°C)
BEDROCK											
<i>Background (Upgradient) Wells</i>											
MW-10D	Nov-00	ND		0.5	<0.10	382	57.4	42.2	<0.07	7.0	15.1
<i>Plume Wells</i>											
MW-18D	Nov-00	ND		0.0	0.273	324	39.8	23.5	0.17	7.3	14.4
MW-20D	Nov-00	230		0.0	<0.10	449	157	51.7	1.7	9.3	14.2
MW-25D	Nov-00	16.0		1.5	<0.10	<10.0	<1.0	22.7	<0.07	12.7	12.6
AVERAGE	--	--		0.5	0.3	386.5	98.4	32.6	0.9	--	--
<i>Downgradient and Sidegradient Wells</i>											
MW-6D	Nov-00	ND		0.3	<0.10	2380	85.8	21.2	0.19	7.7	10.8
MW-23D	Nov-00	0.3		1.6	<0.10	<10.0	<1.0	18.8	<0.07	8.9	12.7
MW-26D	Nov-00	ND		2.4	0.207	<10.0	2.1	28.3	<0.07	10.4	12.1
MW-27D	Nov-00	ND		0.0	<0.10	<10.0	2.0	22.8	0.23	10.0	10.8
AVERAGE	--	--		1.1	0.05	595	22	22.8	0.1	--	--

NOTES

* value discarded for averaging
 ug/L Microgram per liter
 mg/L Milligram per liter

S.U. Standard pH units
 °C Degrees Celsius
 ND Not detected

Table 4-2. 2006 Geochemical Water Quality Data, Groundwater Quality Assessment, Groundwater Remediation Progress and Proposed Updated Remediation Program Supplemental Report, Nepera Harriman Site, Harriman, NY, October 2007.

			Benzene (ug/L)	Dissolved Oxygen (mg/L)	Nitrate (mg/L)	Dissolved Manganese (ug/L)	Dissolved Iron (ug/L)	Sulfate (mg/L)	Methane (mg/L)	pH (S.U.)	Temperature (°C)
OVERBURDEN AQUIFER											
<i>Plume Wells</i>											
MW-16S	Jun-06		1,100	0.1	0.077	807	5570	1	--	7.4	14.6
MW-20S	Jun-06		100	0.1	ND	311	1340	46.7	--	7.5	12.7
MW-25S	Jun-06		620	0.2	ND	940	3050	2.08	--	7.2	16.5
MW-33	Jun-06		74	1.1	--	--	--	--	--	7.4	12.1
MW-37S	Jun-06		130	0.3	--	--	--	--	--	7.1	14.4
MW-53D	Jun-06		460	0.3	ND	340	5620	0.295	--	6.6	14.4
OW-6	Jun-06		12,000	0.3	ND	1770	10700	0.926	--	5.3	14.1
OW-7	Jun-06		3,500	0.6	0.068	3760	12300	22.2	--	6.3	14.4
AVERAGE	--		--	0.4	0.024	1320	6430	12.2	--	--	--
<i>Downgradient and Sidegradient Wells</i>											
MW-1S	Jun-06		ND	0.2	--	--	--	--	--	7.4	13.0
MW-5S	Jun-06		ND	5.8	--	--	--	--	--	11.0	13.0
MW-7S	Jun-06		ND	0.3	--	--	--	--	--	7.3	13.3
MW-8S	Jun-06		ND	6.1	ND	431	5630	44.7	--	7.0	12.0
MW-11S	Jun-06		ND	0.1	--	--	--	--	--	7.1	13.3
MW-12S	Jun-06		0.4	0.2	--	--	--	--	--	8.4	14.6
MW-24S	Jun-06		ND	1.1	0.142	464	362	841*	--	7.0	12.8
MW-35S	Jun-06		ND	0.3	--	--	--	--	--	7.1	13.9
RW-1R	Jun-06		0.5 J	0.3	0.031	669	8300	42.9	--	5.4	12.9
AVERAGE	--		--	1.6	0.058	521	4760	44	--	--	--

Table 4. 2006 Geochemical Water Quality Data, Groundwater Quality Assessment, Groundwater Remediation Progress and Proposed Updated Remediation Program, Supplemental Report, Nepera Harriman Site, Harriman, NY, October 2007.

			Benzene (ug/L)	Dissolved Oxygen (mg/L)	Nitrate (mg/L)	Dissolved Manganese (ug/L)	Dissolved Iron (ug/L)	Sulfate (mg/L)	Methane (mg/L)	pH (S.U.)	Temperature (°C)
BEDROCK AQUIFER											
<i>Plume Wells</i>											
MW-20D	Jun-06		87	0.4	--	--	--	--	--	9.6	13.9
<i>Downgradient and Sidegradient Wells</i>											
MW-6D	Jun-06		ND	0.2	--	--	--	--	--	8.4	11.7
MW-26D	Jun-06		ND	0.8	--	--	--	--	--	9.9	14.7
AVERAGE			--	0.5	--	--	--	--	--	--	--

NOTES

* value discarded for averaging
 ug/L Microgram per liter
 mg/L Milligram per liter
 S.U. Standard pH units
 °C Degrees Celsius
 ND Not detected

Table 6-1: Monitoring Well Information, Groundwater Quality Assessment, Groundwater Remediation Progress and Proposed Updated Remediation Program - Supplemental Report, Nepera Harriman Site, Harriman, NY, October 2007.

Monitoring Well	Sampling* **	Diameter (inches)	Finish	Elevation of the top of casing	Well Depth (bgs)	Screen Depth/Open Borehole (bgs)		Screen/Borehole Elevation		Top of Aquifer Depth (bgs)	Top of Bedrock Depth (bgs)	Hydrogeologic Unit Monitored	Consultant	
						From (Top)	To (Bottom)	Top	Bottom				Name	Date Installed
MW-1S		4	Stickup	522.77	25.0	15.0	25.0	507.77	497.77	13	77.5	Overburden Aquifer	CA Rich	1985
MW-2S		4	Stickup	530.58	22.5	12.5	22.5	518.08	508.08	12	28	Overburden Aquifer	CA Rich	6/3/85
MW-3S		4	Stickup	525.70	25.0	15.0	25.0	510.70	500.70	10	ND	Overburden Aquifer	CA Rich	6/3/85
MW-4S		4	Stickup	524.74	52.5	42.5	52.5	482.24	472.24	17	56	Overburden Aquifer	CA Rich	6/4/85
MW-5S		4	Stickup	535.26	45.0	35.0	45.0	500.26	490.26	NA	NA	Overburden Aquifer	CA Rich	6/6/85
MW-7S	SA	4	Stickup	524.69	36.0	26.0	36.0	498.69	488.69	25	NA	Overburden Aquifer	CA Rich	6/10/85
MW-8S	SA	4	Stickup	526.24	70.0	65.0	70.0	461.24	456.24	55	70	Overburden Aquifer	CA Rich	6/18/85
MW-9S		4	Stickup	529.59	21.0	14.0	21.0	515.59	508.59	12	26	Overburden Aquifer	CA Rich	6/18/85
MW-11S		4	Stickup	527.44	50.0	45.0	50.0	482.44	477.44	NA	NA	Overburden Aquifer	CA Rich	7/2/85
MW-12S		2	Flushmount	530.21	35.0	25.0	35.0	505.21	495.21	NA	NA	Overburden Aquifer	NA	1985
MW-13S		2	Flushmount	530.36	37.0	27.0	37.0	503.36	493.36	NA	NA	Overburden Aquifer	NA	1985
MW-16S	SA	4	Stickup	534.71	45.0	35.0	45.0	499.71	489.71	27	NA	Overburden Aquifer	CA Rich	9/13/85
MW-20S	SA	4	Flushmount	528.61	27.0	17.0	27.0	511.61	501.61	13	ND	Overburden Aquifer	DaM	12/21/88
MW-21S		4	Stickup	544.67	25.0	15.0	25.0	529.67	519.67	15	42	Overburden Aquifer	DaM	1/16/89
MW-24S	SA^	4	Stickup	527.86	17.5	7.5	17.5	520.36	510.36	8	ND	Overburden Aquifer	DaM	12/20/88
MW-25S	SA	4	Stickup	535.16	28.0	23.0	28.0	512.16	507.16	19	48	Overburden Aquifer	CRA	7/11/91
MW-27S		4	Stickup	535.09	30.0	30.0	35.0	505.09	500.09	26	69.5	Overburden Aquifer	CRA	7/26/91
MW-33S	SA	2	Flushmount	535.74	19.0	4.0	19.0	531.74	516.74	12	ND	Overburden Aquifer	AGM	8/30/02
MW-35S		2	Flushmount	524.92	35.5	25.5	35.5	499.42	489.42	23	ND	Overburden Aquifer	AGM	11/20/03
MW-36S		2	Flushmount	525.33	35.0	25.0	35.0	500.33	490.33	21	ND	Overburden Aquifer	AGM	11/21/03
MW-37S		2	Flushmount	524.99	24.0	14.0	24.0	510.99	500.99	11	ND	Overburden Aquifer	AGM	11/24/03
OW-6	SA	2	Stickup	534.51	30.0	20.0	30.0	514.51	504.51	22	ND	Overburden Aquifer	AGM	8/7/00
OW-7	SA	2	Stickup	534.82	30.0	20.0	30.0	514.82	504.82	24	ND	Overburden Aquifer	AGM	8/7/00
R-1		6		533.33	41.0	31.0	41.0	502.33	492.33	NA	NA	Overburden Aquifer	LNY	10/15/65
RW-1**		6	Vault	530.57	55.0	45.0	55.0	485.57	475.57	40	ND	Overburden Aquifer	DaM	1/19/89
RW-1R	SA	6	Vault	529.78	56.0	48.0	56.0	481.78	473.78	40	ND	Overburden Aquifer	AGM	2/2/05
MW-53D	SA	4	Flushmount	532.31	57.0	47.0	57.0	485.31	475.31	NA	NA	Overburden Aquifer	AGM	11/3/99
PZ-1		2	Stickup	544.46	32.0	27.0	32.0	517.46	512.46	1	ND	Overburden Aquifer	CRA	7/15/91
PZ-2		2	Flushmount	531.86	53.0	48.0	53.0	483.86	478.86	3	ND	Overburden Aquifer	CRA	7/9/91
PZ-3		2	Flushmount	525.49	35.0	30.0	35.0	495.49	490.49	25	ND	Overburden Aquifer	CRA	7/22/91
MW-15S	SA	4	Stickup	534.96	17.0	7.0	17.0	527.96	517.96	NA	NA	Overburden Aquitard	CRA	9/16/85
MW-17S	SA	4	Stickup	534.42	14.0	4.0	14.0	530.42	520.42	NA	NA	Overburden Aquitard	CRA	9/17/85
MW-19S		4	Stickup	534.85	10.0	5.0	10.0	529.85	524.85	NA	NA	Overburden Aquitard	CRA	9/17/85
MW-22S(1)		4	Stickup	524.17	13.0	3.0	13.0	521.17	511.17	ND	ND	Overburden Aquitard	DaM	1/23/89
MW-23S(1)		4	Stickup	524.21	15.0	5.0	15.0	519.21	509.21	21	77	Overburden Aquitard	DaM	1/23/89
MW-26S	SA	4	Stickup	522.68	11.0	6.0	11.0	516.68	511.68	38	ND	Overburden Aquitard	CRA	7/26/91
MW-28S(2)	SA^	2	Stickup	523.89	13.0	3.0	13.0	520.89	510.89	ND	ND	Perched Unit	AGM	7/31/00
MW-29S(2)	SA^	2	Stickup	522.54	13.0	3.0	13.0	519.54	509.54	ND	ND	Perched Unit	AGM	8/8/00
MW-34	SA	2	Flushmount	533.79	19.0	4.0	19.0	529.79	514.79	>15	ND	Overburden Aquitard	AGM	8/30/02
MW-35AQ		2	Flushmount	524.82	19.5	9.5	19.5	515.32	505.32	23	ND	Overburden Aquitard	AGM	11/20/03
MW-36AQ		2	Flushmount	525.36	19.7	12.0	18.0	513.36	507.36	21	ND	Overburden Aquitard	AGM	11/21/03
MW-37AQ		2	Flushmount	524.95	10.9	7.9	10.9	517.05	514.05	ND	ND	Overburden Aquitard	AGM	11/28/03
MW-53S		4	Flushmount	532.08	9.0	4.0	9.0	528.08	523.08	ND	ND	Overburden Aquitard/Perched Unit	AGM	11/3/99
PZ-4	SA	2	Stickup	534.18	46.0	41.0	46.0	493.18	488.18	49	ND	Overburden Aquitard	CRA	7/15/91
MW-6D	SA	4	Stickup	525.39	173.0	103.0	173.0	422.39	352.39	25	97	Bedrock Aquifer	CA Rich	6/9/85
MW-10D		6	Stickup	530.57	80.0	28.0	80.0	502.57	450.57	--	20	Bedrock Aquifer	CA Rich	6/25/85
MW-18D		4	Stickup	534.34	80.0	60.0	80.0	474.34	454.34	35	55	Bedrock Aquifer	CA Rich	9/20/85
MW-20D	SA	3 7/8	Flushmount	528.60	85.0	65.0	85.0	463.60	443.60	13	60	Bedrock Aquifer	DaM	1/5/89
MW-21D		3 7/8	Stickup	544.79	65.0	45.0	65.0	499.79	479.79	15	42	Bedrock Aquifer	DaM	1/13/89
MW-23D(1)		3 7/8	Stickup	524.28	102.0	77.0	102.0	447.28	422.28	21	77	Bedrock Aquifer	DaM	1/31/89
MW-25D		3.9	Stickup	534.91	70.0	55.0	70.0	479.91	464.91	19	48	Bedrock Aquifer	CRA	7/25/91
MW-26D	SA	2	Stickup	523.09	145.0	135.0	145.0	388.09	378.09	38	110.5	Bedrock Aquifer	CRA	8/2/91
MW-27D		6	Stickup	535.51	99.0	79.0	99.0	456.51	436.51	26	69.5	Bedrock Aquifer	CRA	4/15/92
R-2D		10	Stickup	530.95	240.0	33.0	240.0	497.95	290.95	NA	33	Overburden and Bedrock Aquifer	LNY	5/21/65
R-3D		10	Stickup	525.93	62.0	62.0	72.0	463.93	453.93	44	62	Bedrock Aquifer	LNY	11/6/79

DaM---Dames and Moore

Boyd---Body Artesian Well Co., Inc.

(1) Off-Site Wells.

Boyd---Body Artesian Well Co., Inc. *** SA---Semi-annual monitoring program for VOC (BTEX) and SVOC(Pyridine, alpha-picoline, 2-amino-pyridine)

LNY---Layne-New York Co., Inc. ^ Semi-annual sampling for Mercury

(2) Erosion Evaluation Well: ** RW-1 was replaced by RW-1R

Table 6-1: Monitoring Well Information, Groundwater Quality Assessment, Groundwater Remediation Progress and Proposed Updated Remediation Program - Supplemental Report, Nepera Harriman Site, Harriman, NY, October 2007.

Monitoring Well	Monitoring Well	Installation Rationale	Well Function
MW-1S	MW-1S	Site perimeter	Plume Fringe
MW-2S	MW-2S	Site perimeter	Up-gradient
MW-3S	MW-3S	Site perimeter	Sentinel
MW-4S	MW-4S	Site perimeter	Sentinel
MW-5S	MW-5S	Site perimeter	Sentinel
MW-7S	MW-7S	Site perimeter	Sentinel
MW-8S	MW-8S	Site perimeter	Plume Fringe
MW-9S	MW-9S	Site perimeter	Sentinel
MW-11S	MW-11S	Site perimeter	Plume Fringe
MW-12S	MW-12S	Site perimeter	Plume Fringe
MW-13S	MW-13S	Site perimeter	Plume Fringe
MW-16S	MW-16S	Building 75 Investigation	Plume Centerline
MW-20S	MW-20S	On-site groundwater quality, groundwater elevation, vertical gradient	Plume Centerline
MW-21S	MW-21S	Up-gradient site perimeter - monitor groundwater entering site	Up-gradient
MW-24S	MW-24S	Site perimeter/communication with West Branch	Sentinel
MW-25S	MW-25S	Groundwater monitoring point up-gradient of Building 66 and 75 and suspected burial trench	Plume Centerline
MW-27S	MW-27S	Groundwater monitoring point down-gradient of Building 66 and 75 and suspected burial trench	Sentinel
MW-33S	MW-33S	Building 13 seep investigation	Source Area
MW-35S	MW-35S	MW-1 groundwater quality investigation	Plume Fringe
MW-36S	MW-36S	MW-1 groundwater quality investigation	Plume Fringe
MW-37S	MW-37S	MW-1 groundwater quality investigation	Plume Centerline
OW-6	OW-6	Observation well for biosparge pilot test	Source Area
OW-7	OW-7	Observation well for biosparge pilot test	Source Area
R-1	R-1	Plant production well	Production Well
RW-1**	RW-1**	Recovery well	Plume Fringe
RW-1R	RW-1R	Recovery well replacement	Plume Fringe
MW-53D	MW-53D	Area 53 post excavation monitoring	Plume Centerline
PZ-1	PZ-1	Soil borings to provide sub-surface geology - borings finished as piezometers	Up-gradient
PZ-2	PZ-2	Soil borings to provide sub-surface geology - borings finished as piezometers	Plume Lateral
PZ-3	PZ-3	Soil borings to provide sub-surface geology - borings finished as piezometers	Plume Fringe
MW-15S	MW-15S	Building 75 Investigation	Aquitard Wells
MW-17S	MW-17S	Building 75 Investigation	
MW-19S	MW-19S	Building 75 Investigation	
MW-22S(1)	MW-22S(1)	Off-site well - hydraulic communication between groundwater and West Branch	
MW-23S(1)	MW-23S(1)	Off-site well - hydraulic communication between groundwater and West Branch	
MW-26S	MW-26S	To assess impact of the lagoon and river on groundwater levels	
MW-28S(2)	MW-28S(2)	Streambank erosion evaluation	
MW-29S(2)	MW-29S(2)	Streambank erosion evaluation	
MW-34	MW-34	Building 13 seep investigation	
MW-35AQ	MW-35AQ	MW-1 groundwater quality investigation	
MW-36AQ	MW-36AQ	MW-1 groundwater quality investigation	
MW-37AQ	MW-37AQ	MW-1 groundwater quality investigation	
MW-53S	MW-53S	Area 53 post excavation monitoring	
PZ-4	PZ-4	Soil borings to provide sub-surface geology - borings finished as piezometers	
MW-6D	MW-6D	Site perimeter	Sentinel
MW-10D	MW-10D	Site perimeter	Sentinel
MW-18D	MW-18D	Building 75 Investigation	Plume Centerline
MW-20D	MW-20D	On-site groundwater quality, groundwater elevation, vertical gradient	Plume Centerline
MW-21D	MW-21D	Up-gradient site perimeter - monitor groundwater entering site	Up-gradient
MW-23D(1)	MW-23D(1)	Off-site well - hydraulic communication between groundwater and West Branch	Sentinel
MW-25D	MW-25D	Groundwater monitoring point up-gradient of Building 66 and 75 and suspected burial trench	Plume Centerline
MW-26D	MW-26D	To assess impact of the lagoon and river on groundwater levels	Sentinel
MW-27D	MW-27D	Groundwater monitoring point down-gradient of Building 66 and 75 and suspected burial trench	Sentinel
R-2D	R-2D	Plant production well	Production Well
R-3D	R-3D	Plant production well	Production Well

DaM---Dames and Moore
 Boyd---Body Artesian Well Cr
 (1) Off-Site Wells.



FIGURES



copyright © 2007

- LEGEND**
- █ START REMEDIATION RAMP & TREAT (SEPTEMBER 2001)
 - █ START REMEDIATION OPERATION (DECEMBER 2001)
 - █ STOP GROUNDCOVER RAMP & TREAT (SEPTEMBER 2004)
 - MONITORING WELL IN OVERBURDEN
 - MONITORING WELL IN OVERBURDEN AND ADJACENT (SAND/GRAVEL)
 - MONITORING WELL IN BERDICK ADJACENT
 - APPROX. LIMITS OF EXCAVATION
 - OVERBURDEN ADJACENT GROUNDCOVER CONTROL LINE (JUNE 2006)
- NOTES**
1. R-20 SCREENED IN OVERBURDEN AND OPEN IN BERDICK
 2. MW-23 NOT USED FOR GROUNDCOVER ELEVATION CONTINUING WELL SCREENED IN THE OVERBURDEN ADJACENT AND ADJACENT MONITORING WELLS IN THE OVERBURDEN ADJACENT
 3. GROUNDCOVER REPRESENTS DATA FROM MONITORING WELLS IN THE OVERBURDEN ADJACENT

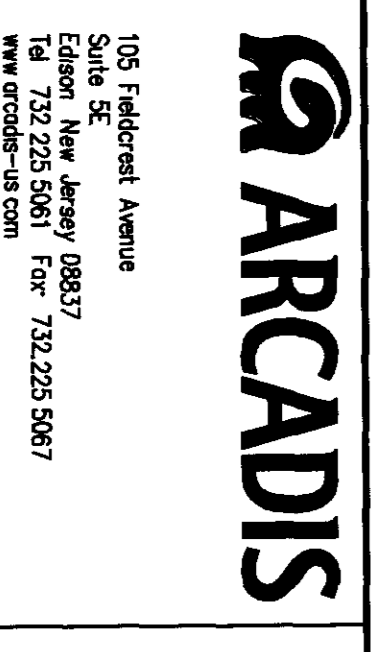
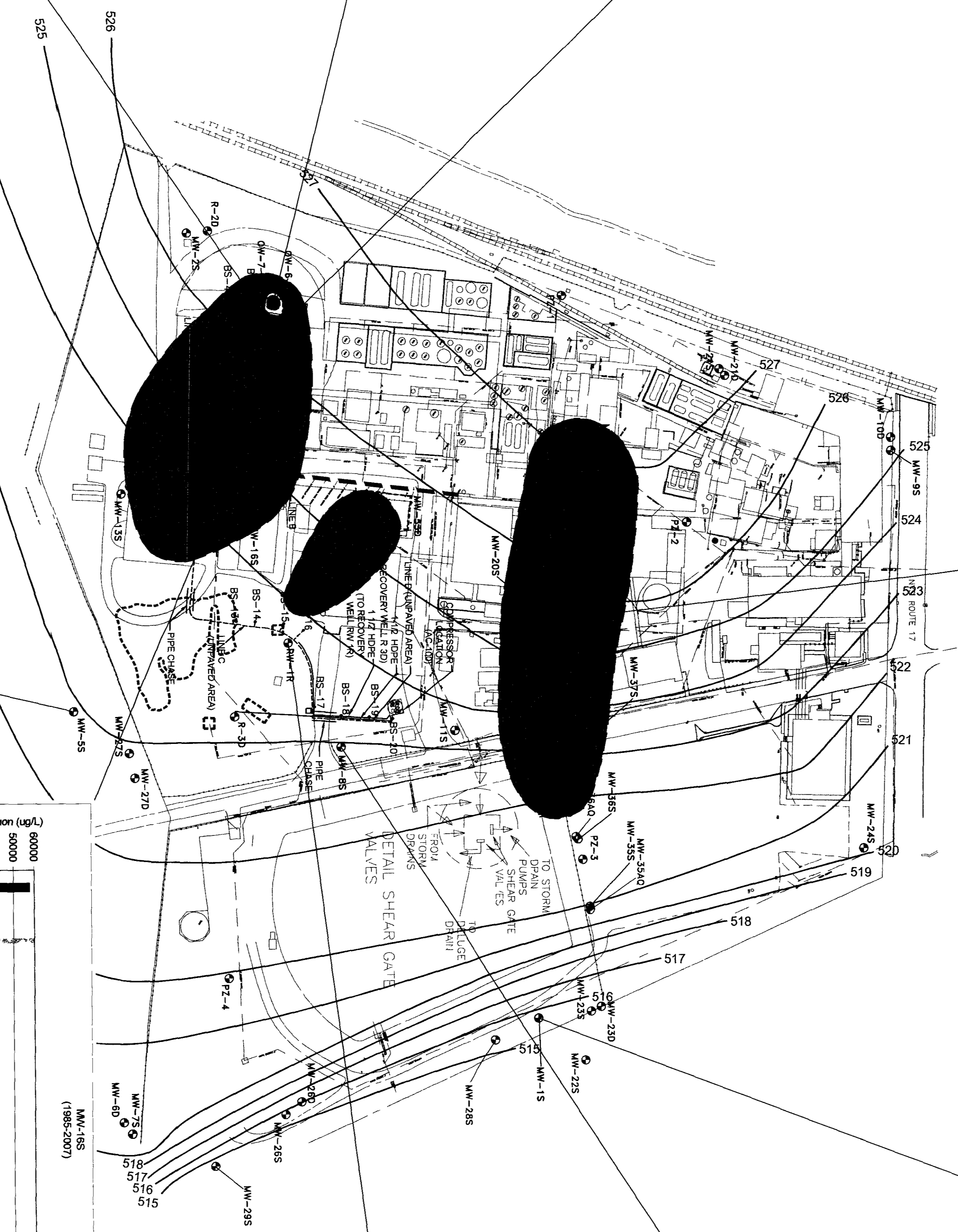
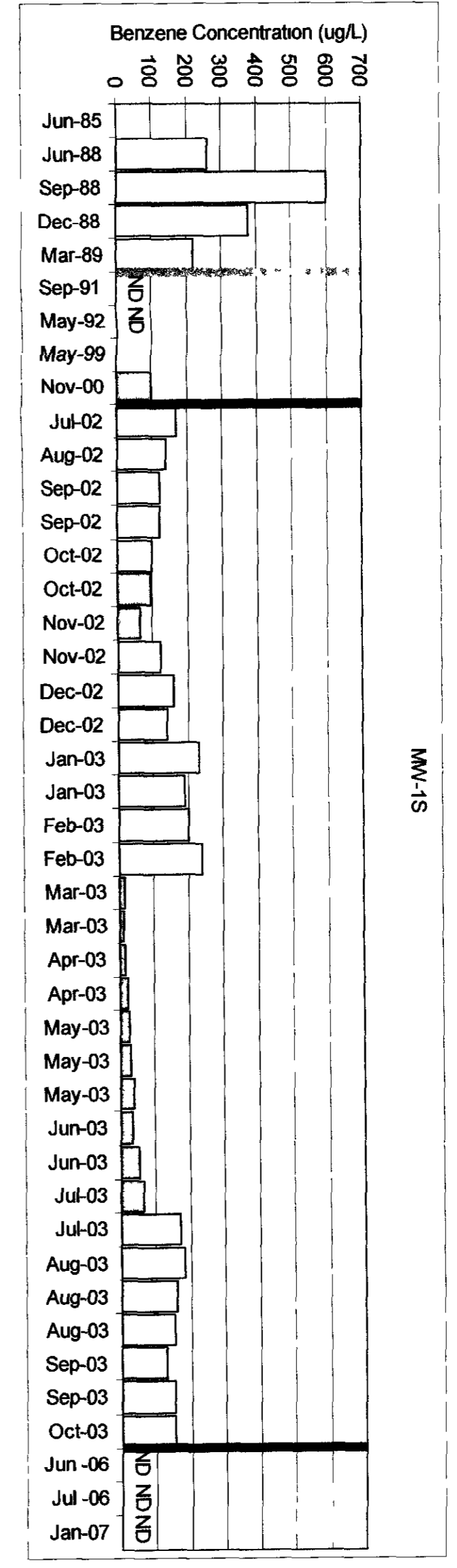
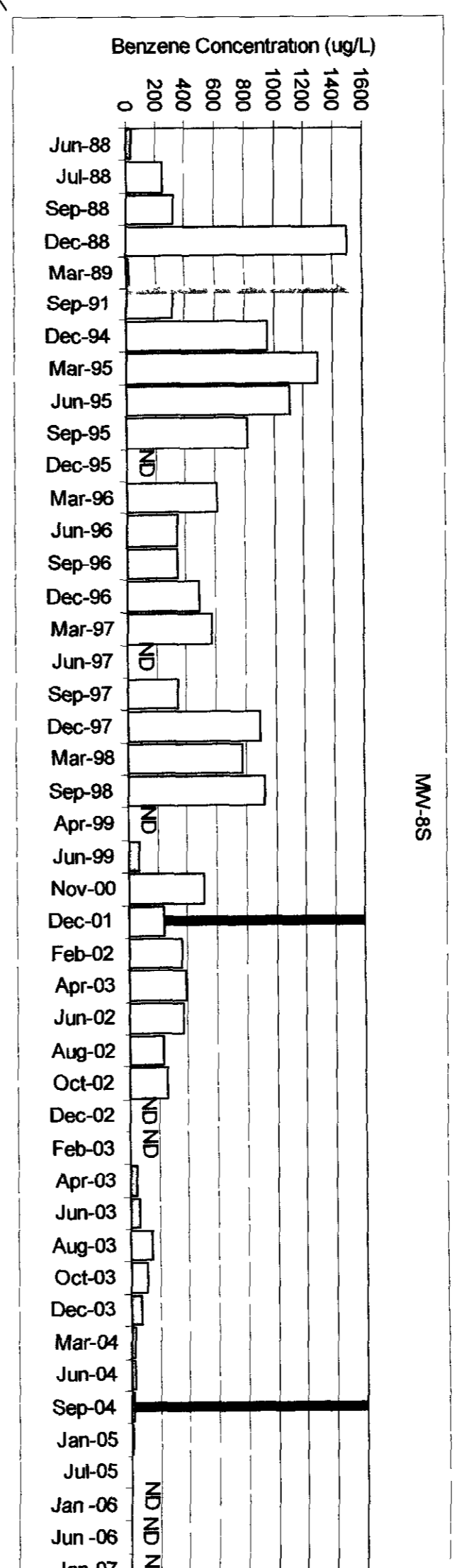
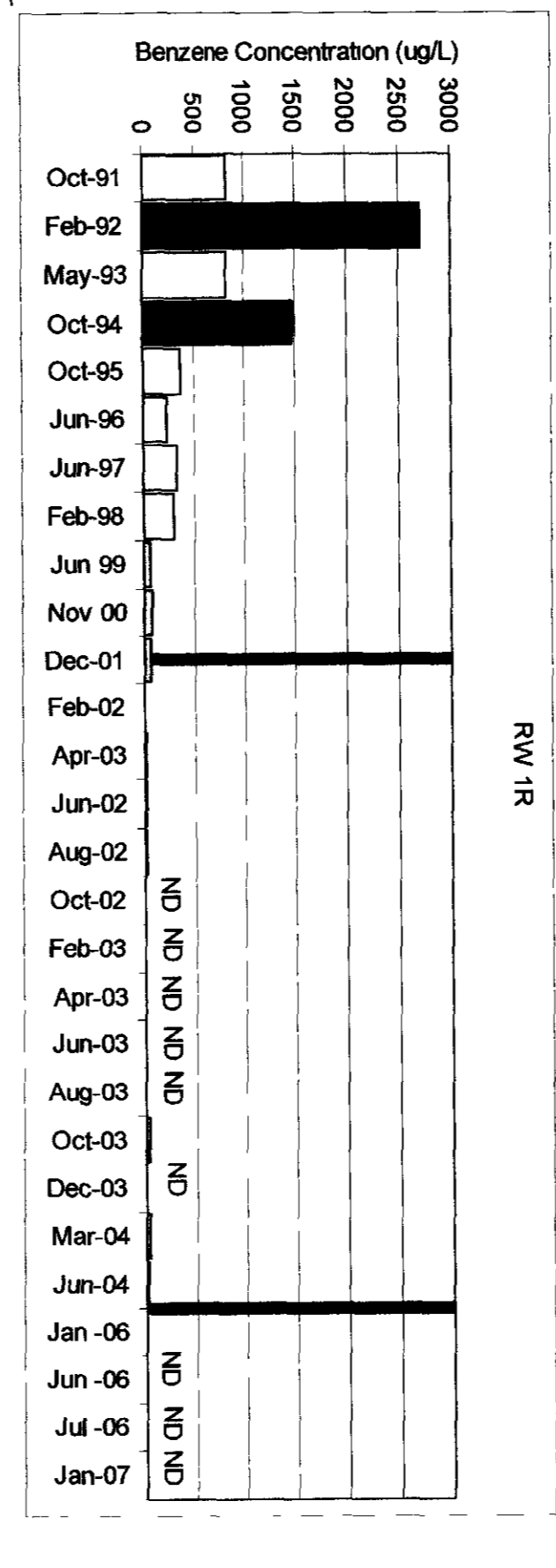
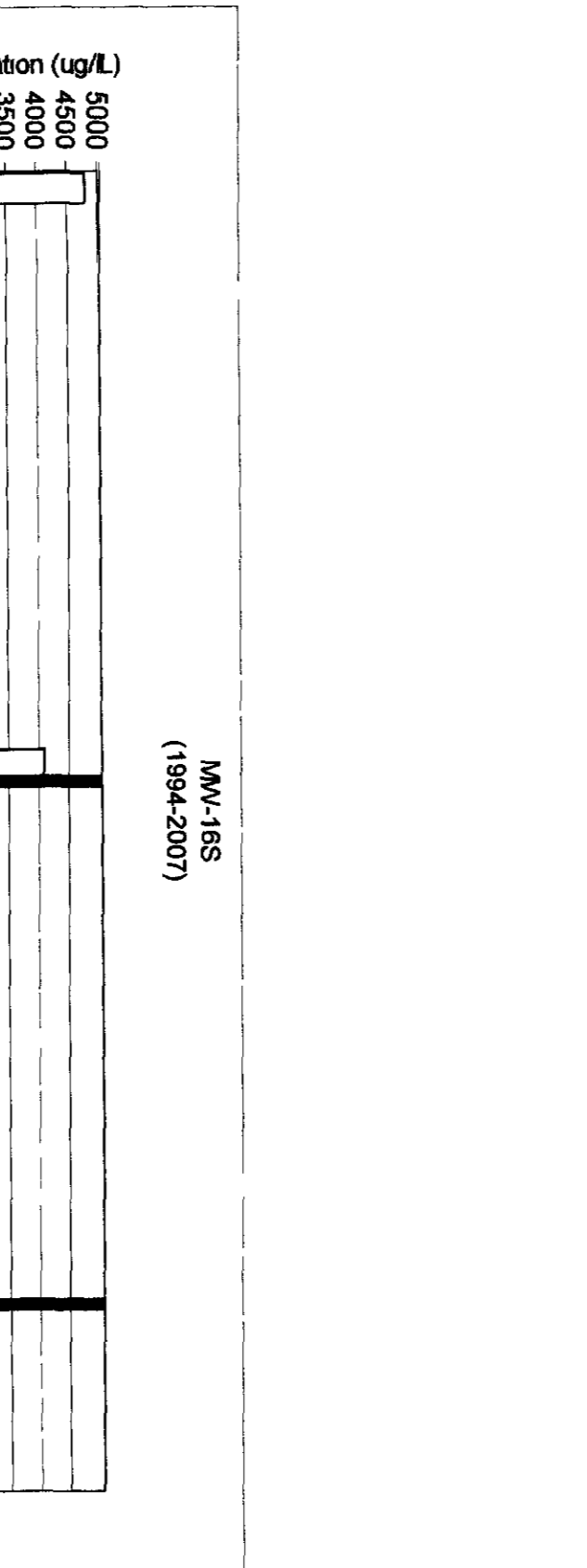
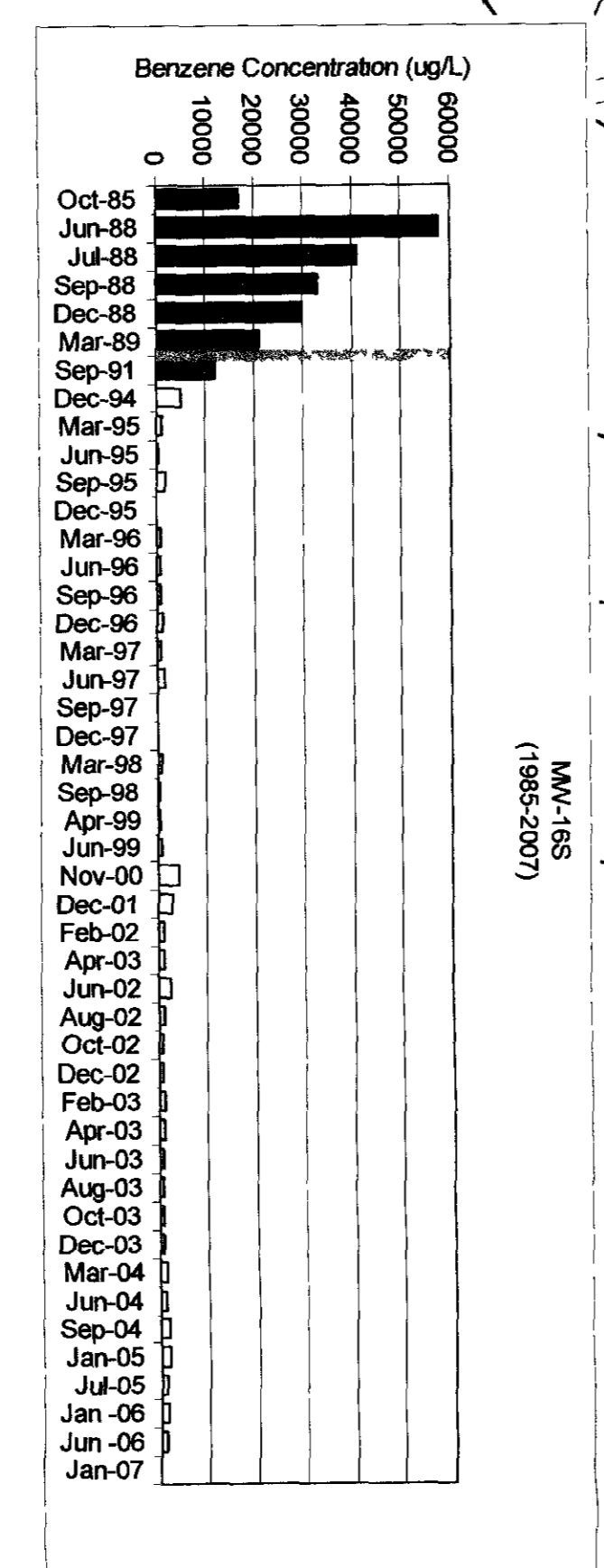
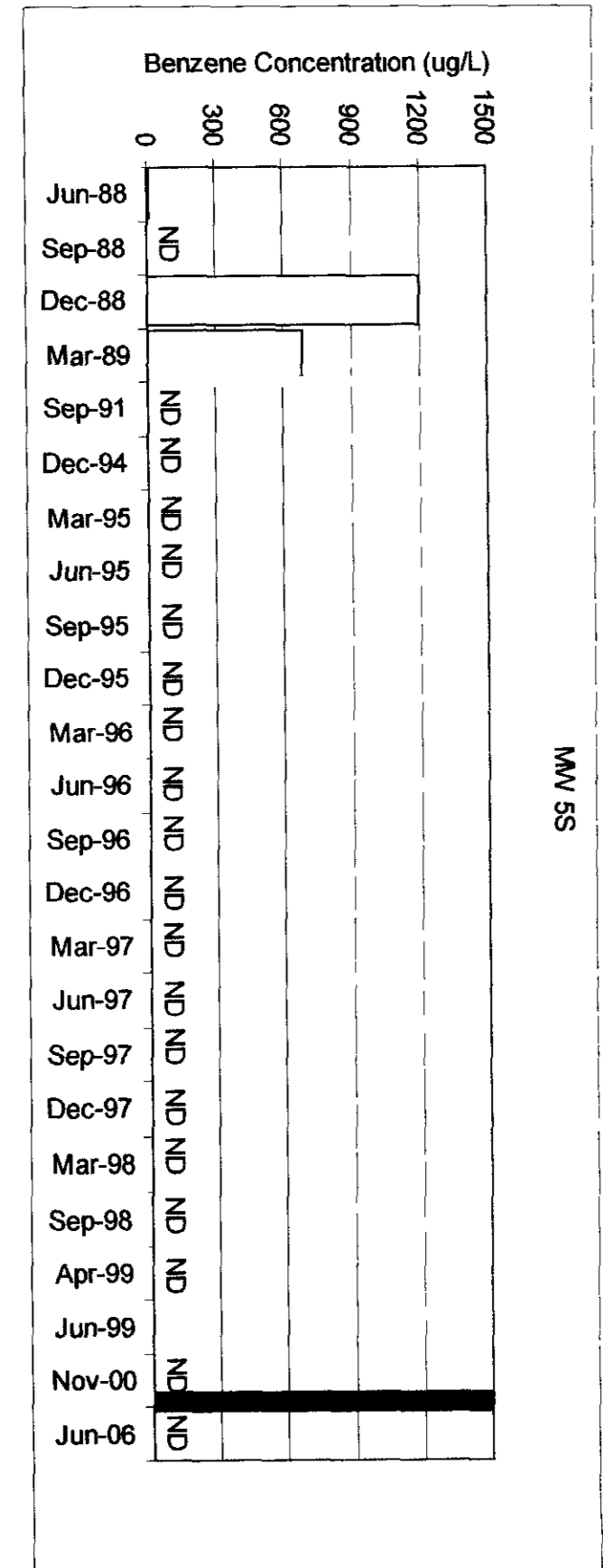
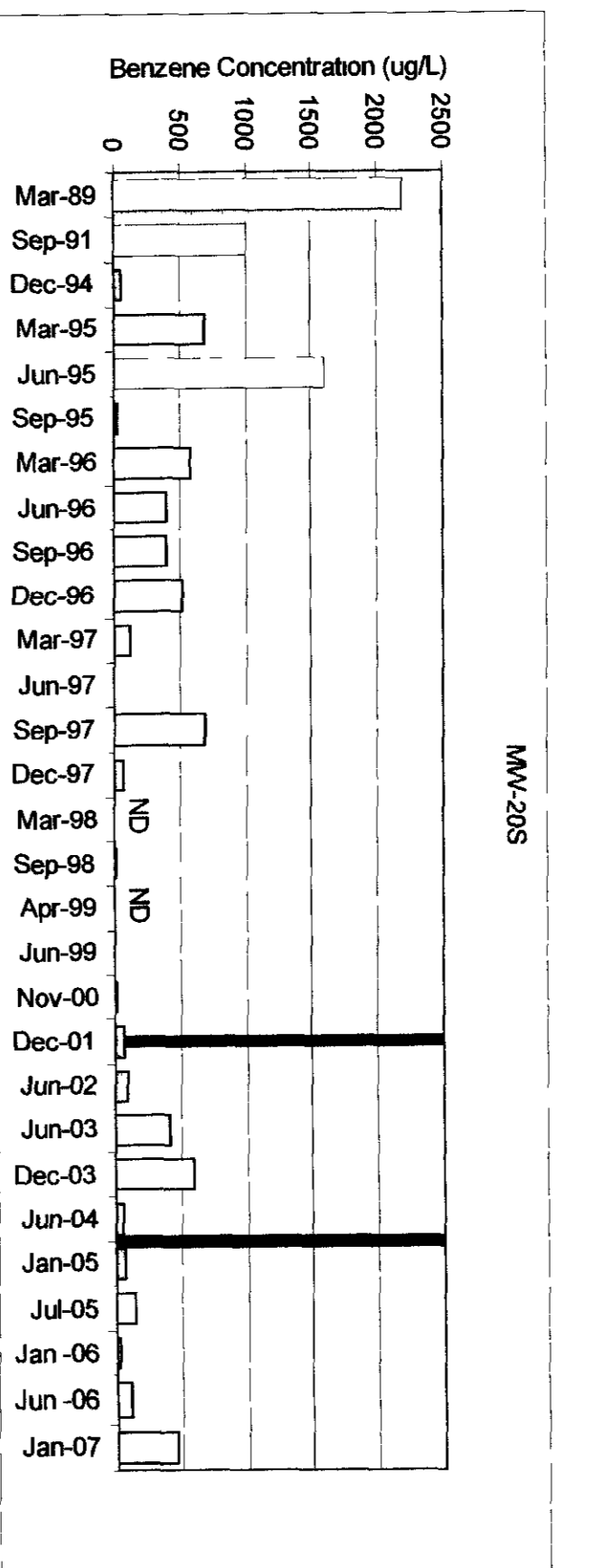
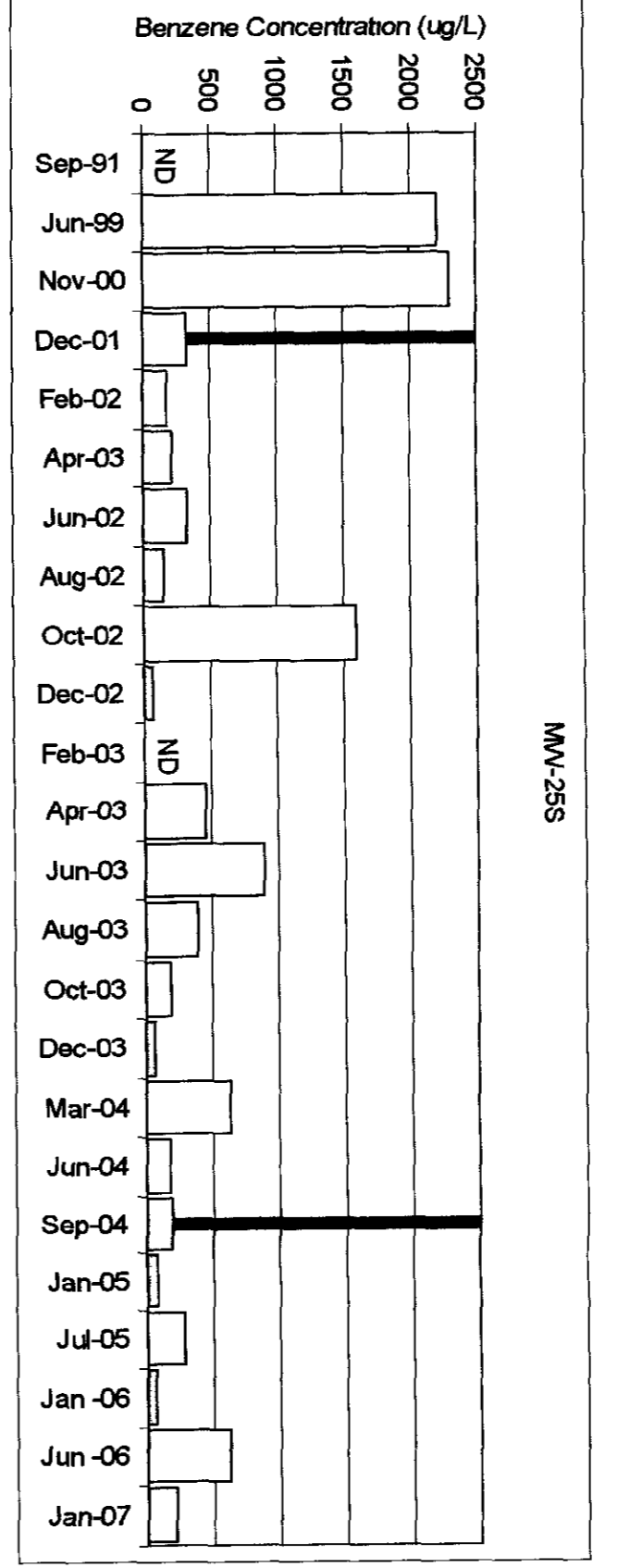
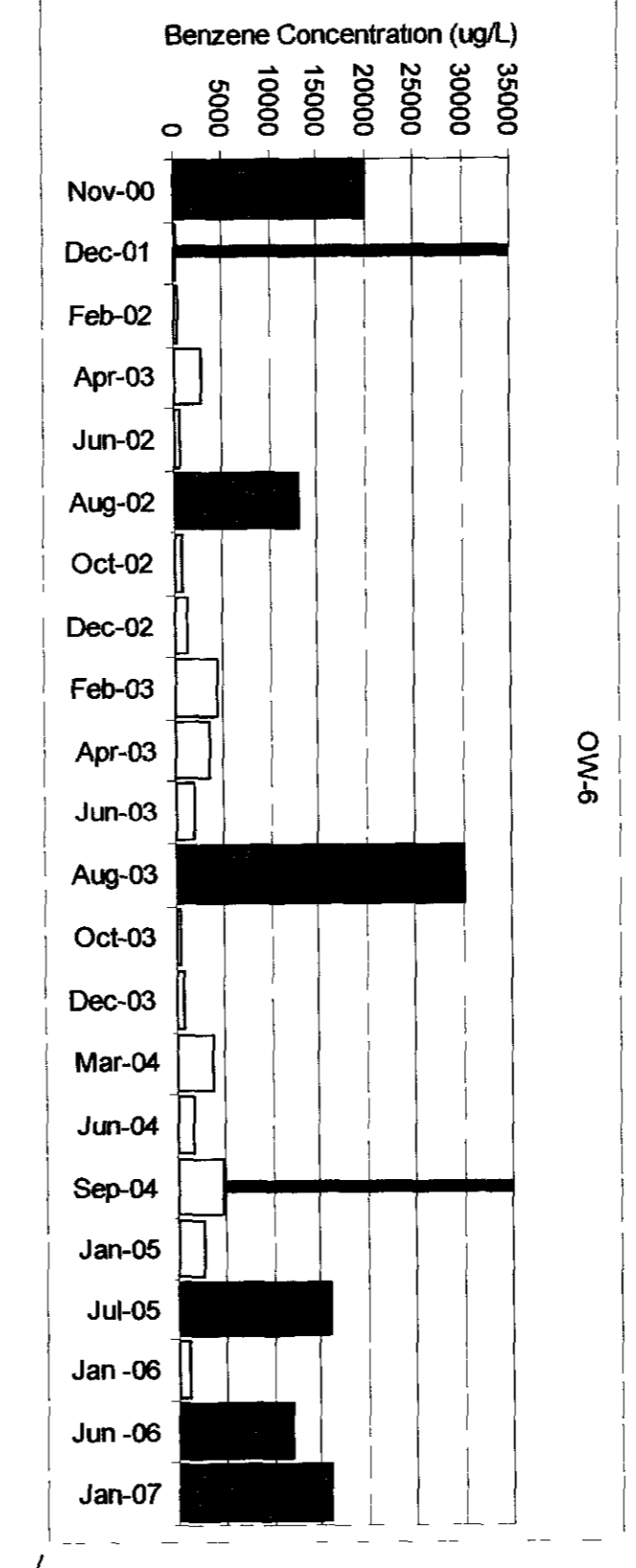
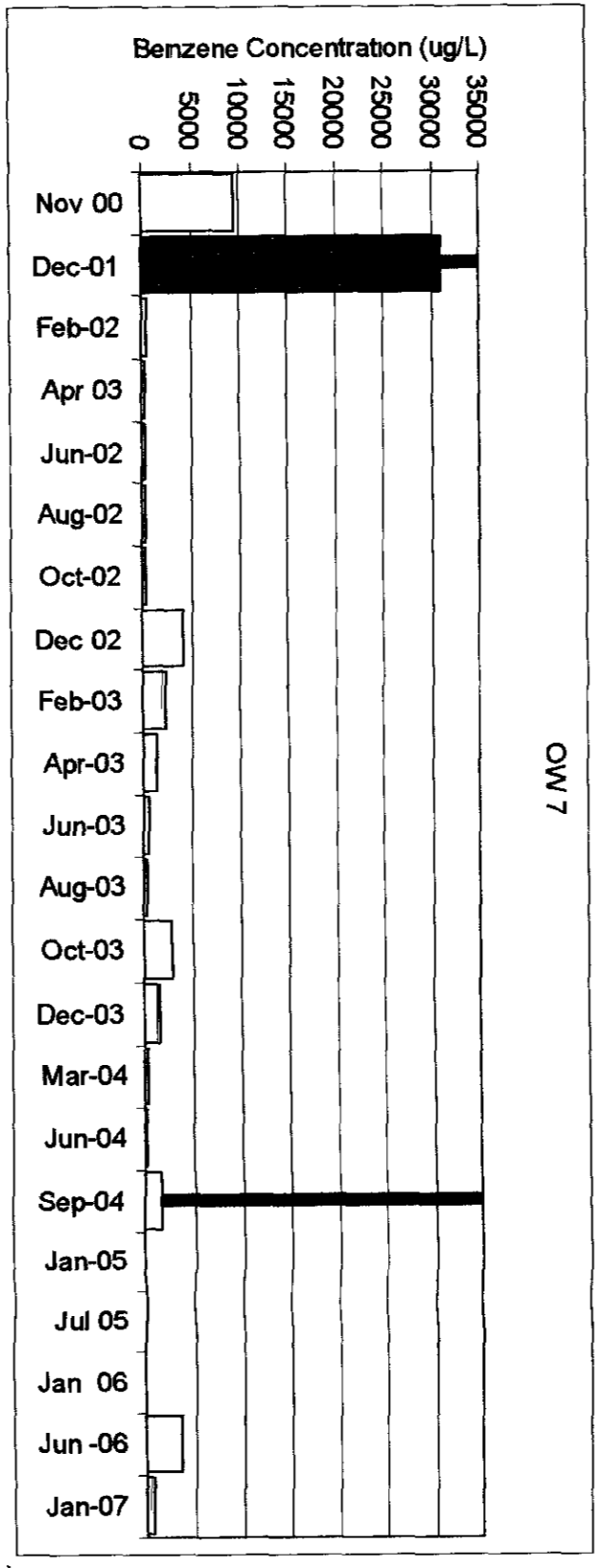
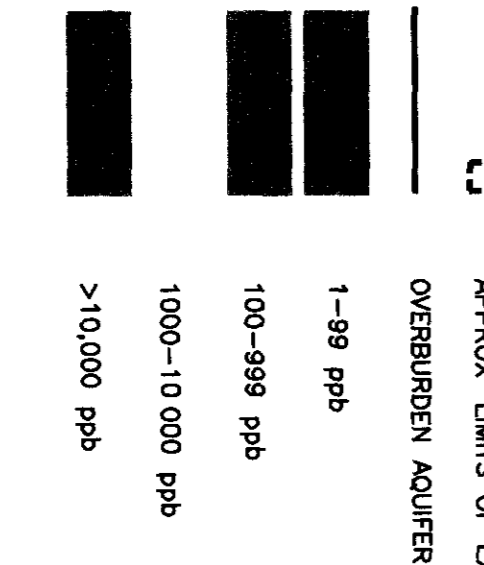

MAYBROOK TRUST
 HARRIMAN, NEW YORK

PROJECT NUMBER: 0007
 SHEET TITLE: GROUNDWATER QUALITY TRENDS FOR SELECT MONITORING WELLS
 PROJECT NUMBER: NAD000389 0007
 DRAWN BY: A. ROBINSON
 CHECKED BY: A. ROBINSON
 DATE: 4-1

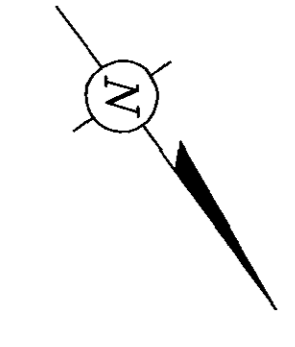

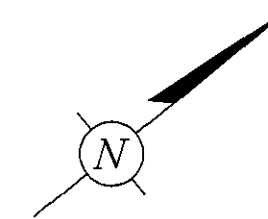

LEGEND

- EXISTING GEOPROBE SOIL BORING
ADVANCED OCTOBER 2006
- OBSERVATION WELL
- ⊙ MONITORING WELL
- BIOSPARGE POINT
- BIOSPARGE TRENCH
- 1-1/2" HDPE PIPE
- BLACK** EXISTING

SAMPLE RESULTS EXPLANATION

SAMPLE ID		GP-4	14-14 5'	20-24'	SAMPLE DEPTH
SAMPLE COLLECTION DATE		10/12/2006	(mg/kg)	(µg/L)	
		Benzene	91	3	
			SOIL ANALYTICAL RESULTS	GROUNDWATER ANALYTICAL RESULTS	

GP-6	12-12 5'	21-25'
10/13/2006	(mg/kg)	(µg/L)
Benzene	26	NA
Toluene	0.36	NA

GP-8	15-15 5'	21-25'
10/13/2006	(mg/kg)	(µg/L)
Benzene	53	420

GP-5	12-12 5'	21-25'
10/13/2006	(mg/kg)	(µg/L)
Benzene	12	240
Toluene	0.099	ND

GP-4	14-14 5'	20-24'
10/12/2006	(mg/kg)	(µg/L)
Benzene	91	3

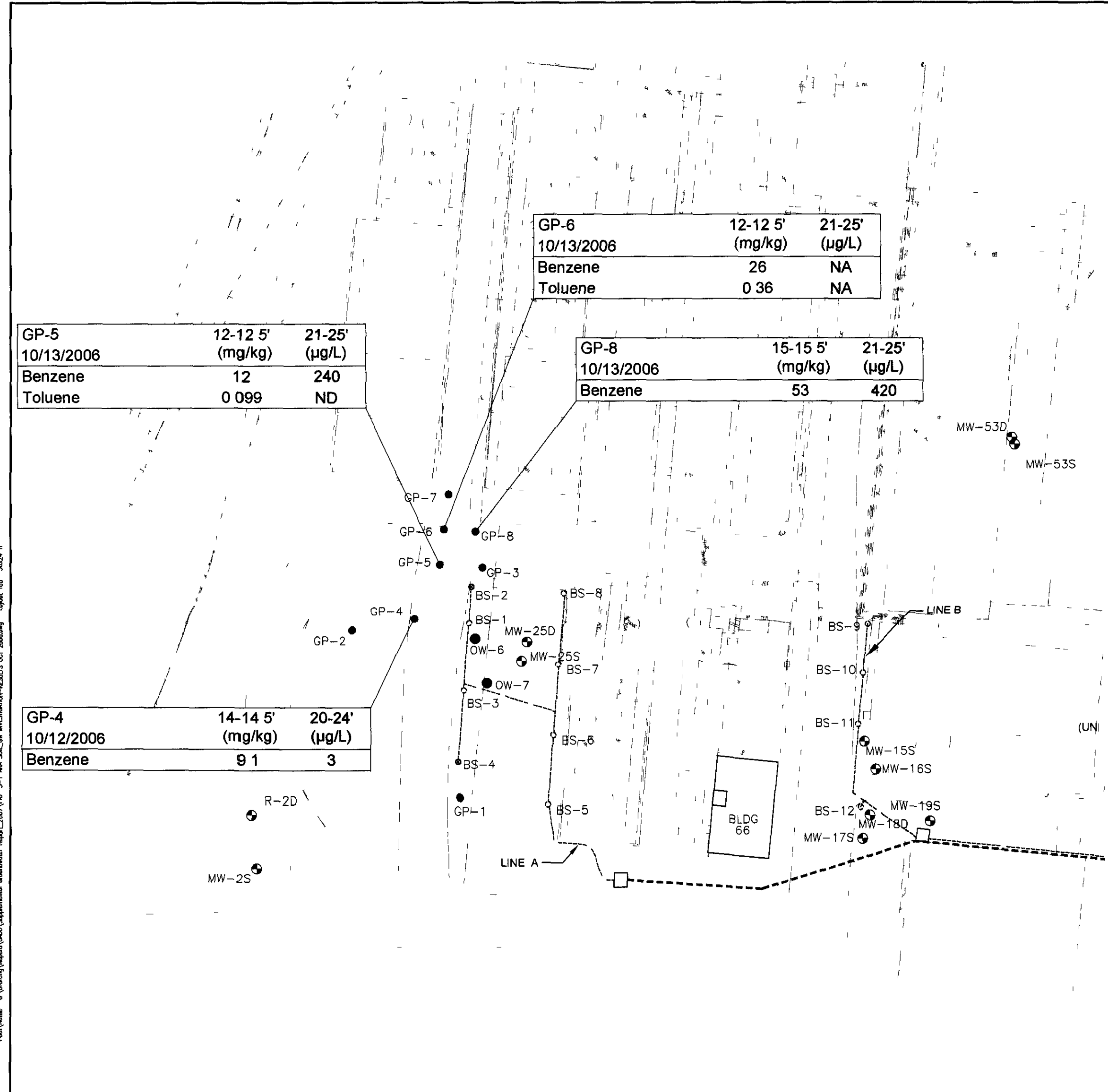

ArcView 4.0a (10.1.1.1) - 12/20/06
 Path: \\server\arcgis\GIS\Projects\HARRIMAN\RESULTS\DOCS\2006.dwg Layout Tab 36204.H
 Copyright © 2007

<p>SCALE IN FEET</p>		KEYPLAN	SEAL	SEAL	<p>105 Fieldcrest Avenue Suite 5E Edison, NJ 08837 Tel: 732.225.5061 Fax: 732.225.5067 www.arcadis-us.com</p>	<p>PROJECT TITLE</p> <p>HARRIMAN INACTIVE WASTE DISPOSAL SITE</p>	<p>PROJECT MANAGER</p> <p>A. ROBINSON</p>	<p>DEPARTMENT MANAGER</p> <p>C. MOTTA</p>	<p>LEAD DESIGN PROF</p> <p>D. HEJER</p>	<p>CHECKED BY</p> <p>D. HEJER</p>
<p>REV ISSUED DATE DESCRIPTION</p>						<p>SHEET TITLE</p> <p>OCTOBER 2006 GEOPROBE SOIL BORING AND GROUNDWATER INVESTIGATION RESULTS</p>		<p>TASK/PHASE NUMBER</p> <p>00007</p>		<p>DRAWN BY</p> <p>A. SANTINI</p>
						<p>PROJECT NUMBER</p> <p>NJ000389 0007</p>		<p>DRAWING NUMBER</p> <p>3-1</p>		

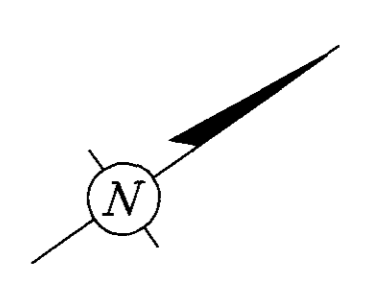
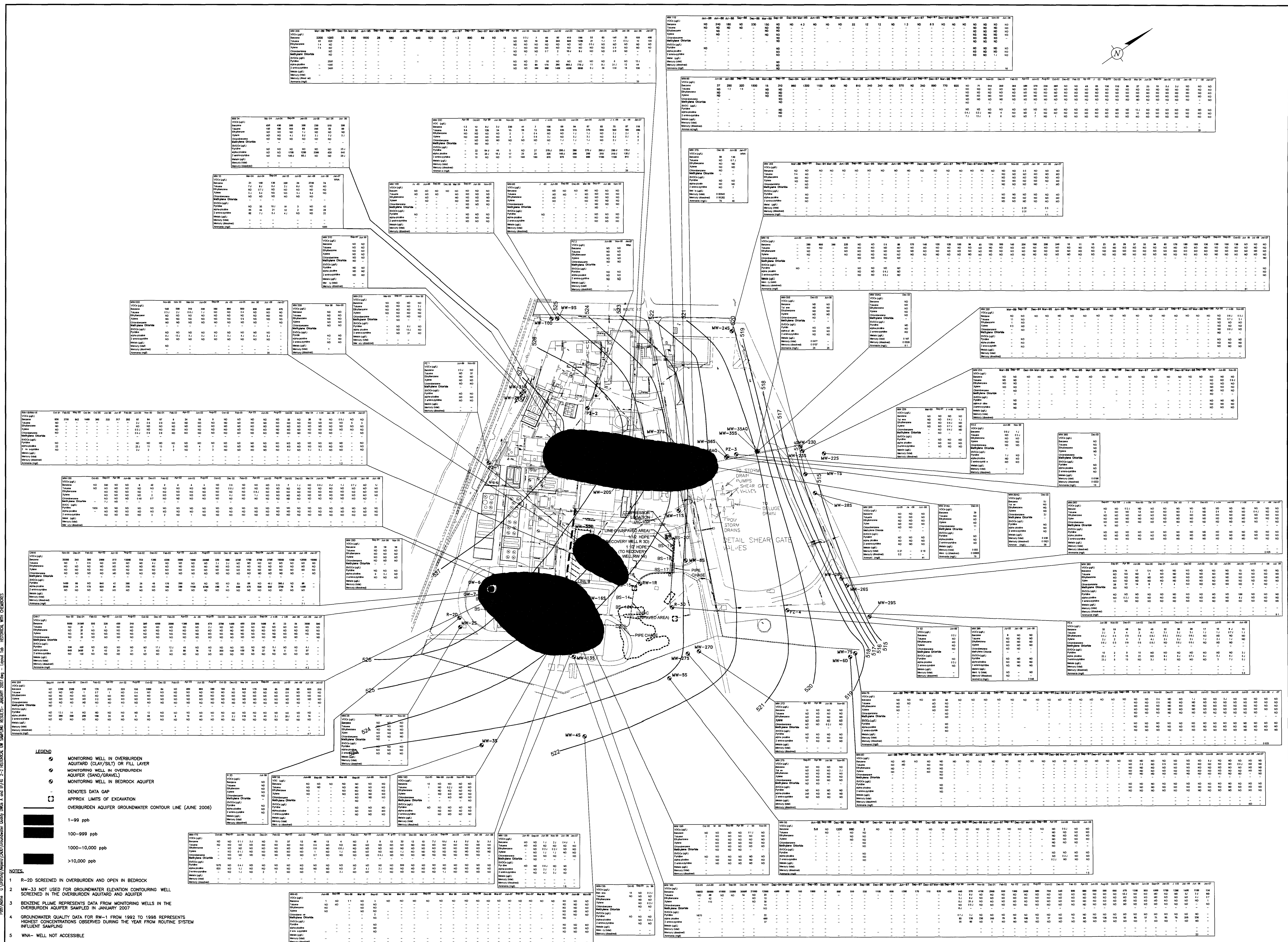

LEGEND

- MONITORING WELL IN OVERBURDEN AQUIFAR (CLAY/SILT OR FILL LAYER)
- MONITORING WELL IN OVERBURDEN AQUIFER (SAND/GRAVEL)
- MONITORING WELL IN BEDROCK AQUIFER
- DENOTES DATA GAP
- APPROX LIMITS OF EXCAVATION
- OVERBURDEN AQUIFER GROUNDWATER CONTOUR LINE (JUNE 2006)
- 1-99 ppb
- 100-999 ppb
- 1000-10,000 ppb
- >10,000 ppb

NOTES

- R-2D SCREENED IN OVERBURDEN AND OPEN IN BEDROCK
- MW-33 NOT USED FOR GROUNDWATER ELEVATION CONTOURING WELL SCREENED IN THE OVERBURDEN AQUIFER AND AQUIFER
- BENZENE PLUME REPRESENTS DATA FROM MONITORING WELLS IN THE OVERBURDEN AQUIFER SAMPLED IN JANUARY 2007
- GROUNDWATER QUALITY DATA FOR MW-1 FROM 1992 TO 1998 REPRESENTS HIGHEST CONCENTRATIONS OBSERVED DURING THE YEAR FROM ROUTINE SYSTEM INFLUENT SAMPLING
- WNA - WELL NOT ACCESSIBLE
- GROUNDWATER CONTOURS BASED ON MEASUREMENTS FROM JUNE 2006

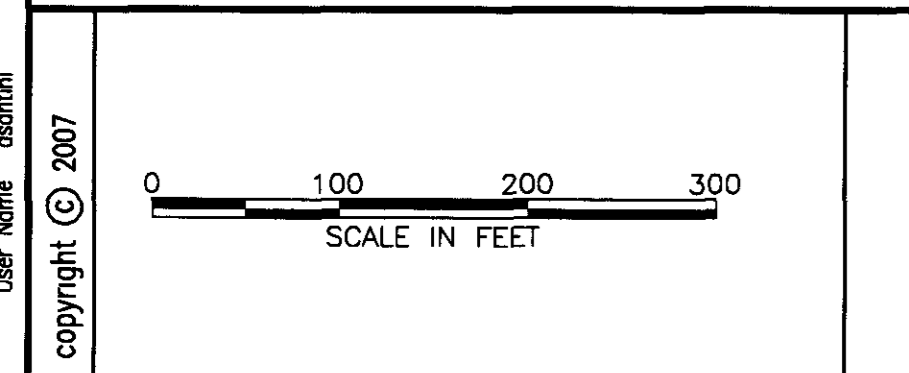

REV	ISSUED DATE	DESCRIPTION

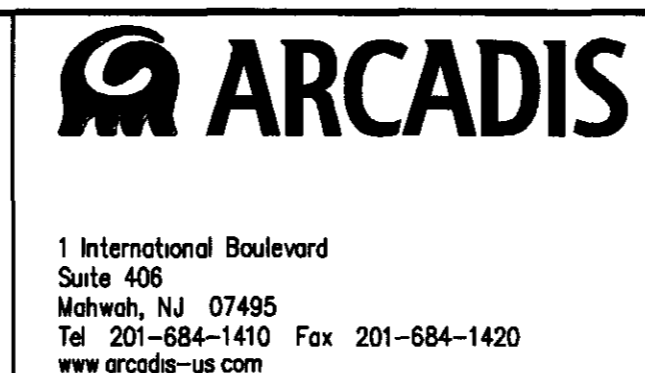

PROJECT TITLE
MAYBROOK TRUST
HARRIMAN, NEW YORK

PROJECT MANAGER
A. ROBINSON

DEPARTMENT MANAGER
C. MOTTA

SHEET TITLE
HISTORICAL GROUNDWATER
SAMPLING RESULTS

PROJECT NUMBER
NJ000389.0007

LEAD DESIGN PROF
D. HEUER

TASK/PHASE NUMBER
00007

CHECKED BY
A. ROBINSON

DRAWN BY
A. SANTINI

BROWNING NUMBER
2-2

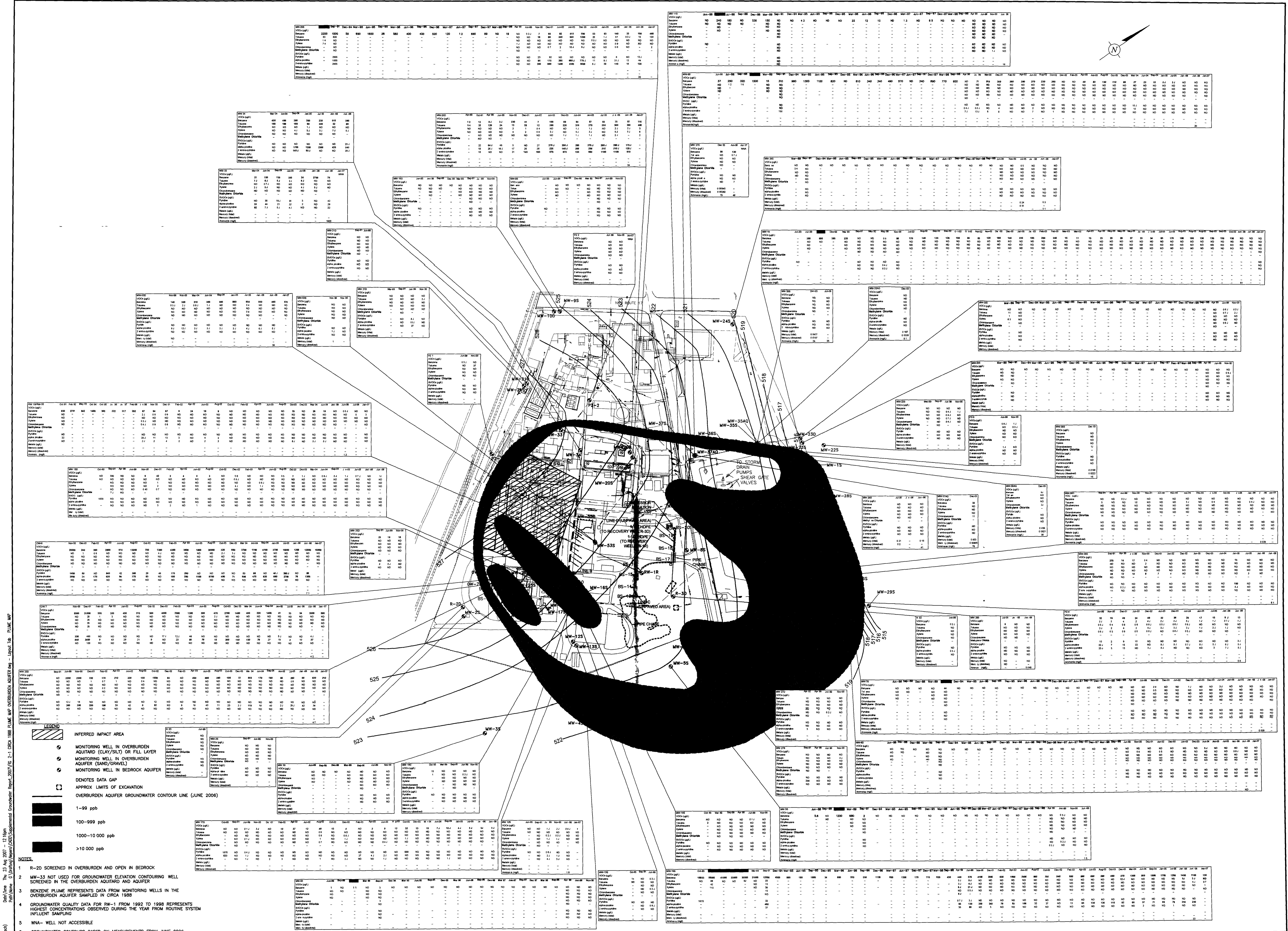

Well ID	Depth (ft)	Screening Interval (ft)	Water Level (ft)	Flow Rate (gpm)	Temperature (°F)	Notes
MW-1	10	10-15	10.5	0.5	55	Accessed
MW-2	10	10-15	10.5	0.5	55	Accessed
MW-3	10	10-15	10.5	0.5	55	Accessed
MW-4	10	10-15	10.5	0.5	55	Accessed
MW-5	10	10-15	10.5	0.5	55	Accessed
MW-6	10	10-15	10.5	0.5	55	Accessed
MW-7	10	10-15	10.5	0.5	55	Accessed
MW-8	10	10-15	10.5	0.5	55	Accessed
MW-9	10	10-15	10.5	0.5	55	Accessed
MW-10	10	10-15	10.5	0.5	55	Accessed
MW-11	10	10-15	10.5	0.5	55	Accessed
MW-12	10	10-15	10.5	0.5	55	Accessed
MW-13	10	10-15	10.5	0.5	55	Accessed
MW-14	10	10-15	10.5	0.5	55	Accessed
MW-15	10	10-15	10.5	0.5	55	Accessed
MW-16	10	10-15	10.5	0.5	55	Accessed
MW-17	10	10-15	10.5	0.5	55	Accessed
MW-18	10	10-15	10.5	0.5	55	Accessed
MW-19	10	10-15	10.5	0.5	55	Accessed
MW-20	10	10-15	10.5	0.5	55	Accessed
MW-21	10	10-15	10.5	0.5	55	Accessed
MW-22	10	10-15	10.5	0.5	55	Accessed
MW-23	10	10-15	10.5	0.5	55	Accessed
MW-24	10	10-15	10.5	0.5	55	Accessed
MW-25	10	10-15	10.5	0.5	55	Accessed
MW-26	10	10-15	10.5	0.5	55	Accessed
MW-27	10	10-15	10.5	0.5	55	Accessed
MW-28	10	10-15	10.5	0.5	55	Accessed
MW-29	10	10-15	10.5	0.5	55	Accessed
MW-30	10	10-15	10.5	0.5	55	Accessed
MW-31	10	10-15	10.5	0.5	55	Accessed
MW-32	10	10-15	10.5	0.5	55	Accessed
MW-33	10	10-15	10.5	0.5	55	Accessed
MW-34	10	10-15	10.5	0.5	55	Accessed
MW-35	10	10-15	10.5	0.5	55	Accessed

NOTES:

- R-20 SCREENED IN OVERBURDEN AND OPEN IN BEDROCK
- MW-33 NOT USED FOR GROUNDWATER ELEVATION CONTOURING WELL SCREENED IN THE OVERBURDEN AQUIFAR AND AQUIFER
- BENZENE PLUME REPRESENTS DATA FROM MONITORING WELLS IN THE OVERBURDEN AQUIFER SAMPLED IN CIRCA 1988
- GROUNDWATER QUALITY DATA FOR MW-1 FROM 1992 TO 1998 REPRESENTS HIGHEST CONCENTRATIONS OBSERVED DURING THE YEAR FROM ROUTINE SYSTEM INFLUENT SAMPLING
- MNA - WELL NOT ACCESSIBLE
- GROUNDWATER CONTOURS BASED ON MEASUREMENTS FROM JUNE 2006

LEGEND:

- INFERRED IMPACT AREA
- MONITORING WELL IN OVERBURDEN AQUIFAR (CLAY/SILT) OR PL. LAYER
- MONITORING WELL IN OVERBURDEN AQUIFER (SAND/GRAVEL)
- MONITORING WELL IN BEDROCK AQUIFER
- DENOTES DATA GAP
- APPROX. LIMITS OF EDUCATION OVERBURDEN AQUIFER GROUNDWATER CONTOUR LINE (JUNE 2006)
- 1-99 ppb
- 100-999 ppb
- 1000-10,000 ppb
- >10,000 ppb

ARCADIS
 105 Faircrest Avenue
 Suite 2E
 Edison, New Jersey 08837
 Tel: 732.225.5561 Fax: 732.225.5567
 www.arcadis-us.com

PROJECT TITLE: MAYBROOK TRUST HARRIMAN, NEW YORK

PROJECT MANAGER: A. ROBINSON
DEPARTMENT MANAGER: C. MOTTA

SHEET TITLE: HISTORICAL GROUNDWATER SAMPLING RESULTS/BENZENE PLUME MAP-OVERBURDEN AQUIFER CIRCA 1988

TASK/PHASE NUMBER: 00015
PROJECT NUMBER: NJ000389 0007

CHECKED BY: A. ROBINSON
DRAWN BY: A. SANTINI
DRAWING NUMBER: 2-1

SCALE IN FEET: 0 100 200 300

ISSUED DATE: _____
DESCRIPTION: _____

Acad Version : R16.2a (LMS Tech) User Name : esantini copyright © 2007
 Date/Time : Mon, 08 Oct 2007 - 4:15pm Path/Name : G:\Drafting\Nepers\CADD\Supplemental Groundwater Report_2007\REV-2007-09\FIG. 6-2 PROPOSED ENHANCED OB AQUIFER MONITORING PROGRAM- PHASE I.dwg - Layout Tab : HISTORICAL WITH CHEMOBIOXES

- LEGEND**
- TEST PITS (1991)
 - ⊕ MONITORING WELL IN OVERBURDEN AQUITARD (CLAY/SILT) OR FILL LAYER
 - ⊕ MONITORING WELL IN OVERBURDEN AQUIFER (SAND/GRAVEL)
 - ⊕ MONITORING WELL IN BEDROCK AQUIFER
 - DENOTES DATA GAP
 - ⊕ APPROX. LIMITS OF EXCAVATION
 - 50 — SOIL GAS ISO-CONCENTRATION CONTOURS (1991)
 - ▨ PROJECTED PHASE I GEOPROBE SURVEY AREAS
 - ▨ POTENTIAL AREA OF AQUITARD MARGIN
 - ▨ 1-99 ppb
 - ▨ 100-999 ppb
 - ▨ 1000-10,000 ppb
 - ▨ >10,000 ppb

- NOTES:**
1. R-2D SCREENED IN OVERBURDEN AND OPEN IN BEDROCK.
 2. MW-33 NOT USED FOR GROUNDWATER ELEVATION CONTOURING. WELL SCREENED IN THE OVERBURDEN AQUITARD AND AQUIFER.
 3. BENZENE PLUME REPRESENTS DATA FROM MONITORING WELLS IN THE OVERBURDEN AQUIFER SAMPLED IN JANUARY 2007.
 4. GROUNDWATER QUALITY DATA FOR RW-1 FROM 1992 TO 1998 REPRESENTS HIGHEST CONCENTRATIONS OBSERVED DURING THE YEAR FROM ROUTINE SYSTEM INFLUENT SAMPLING.
 5. WNA- WELL NOT ACCESSIBLE.
 6. GROUNDWATER CONTOURS BASED ON MEASUREMENTS FROM JUNE 2006.

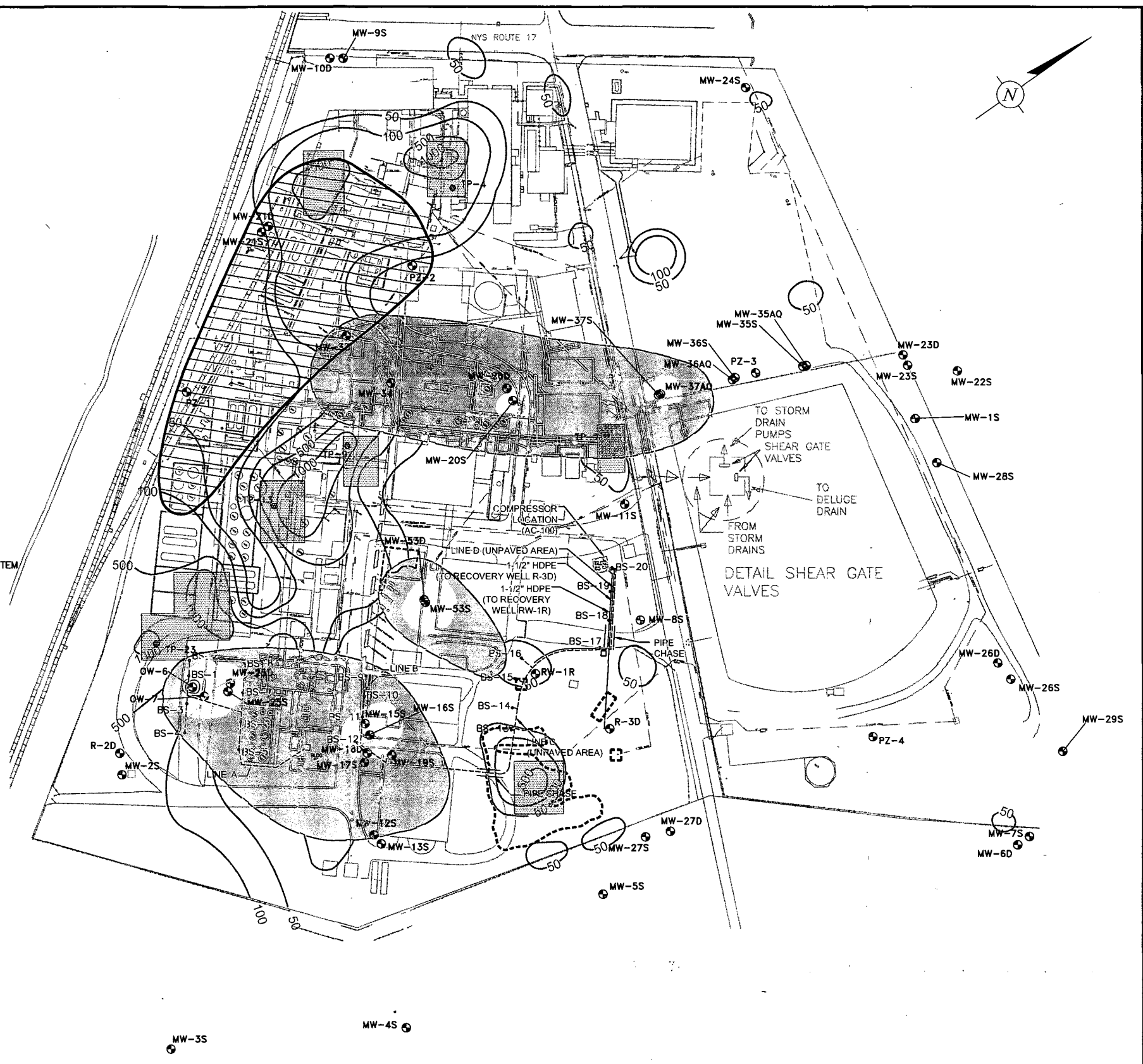

REV.	ISSUED DATE	DESCRIPTION

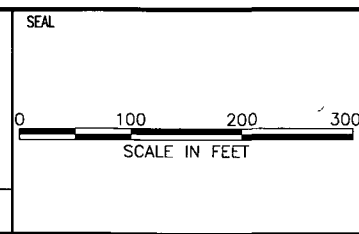

105 Fieldcrest Avenue
Suite 5E
Edison, New Jersey 08837
Tel: 732.225.5061 Fax: 732.225.5067
www.arcadis-us.com

PROJECT TITLE
**MAYBROOK TRUST
HARRIMAN, NEW YORK**

PROJECT MANAGER
A. ROBINSON

DEPARTMENT MANAGER
K. EYRE

SHEET TITLE
**PROPOSED ENHANCED OVERBURDEN
AQUIFER MONITORING PROGRAM-
PHASE I**

LEAD DESIGN PROF.
D. HEUER

TASK/PHASE NUMBER
00007

PROJECT NUMBER
NJ000389.0007

CHECKED BY
A. ROBINSON

DRAWN BY
A. SANTINI

DRAWING NUMBER
6-2

● **Figure 9-1: Historical Data from MW-1S Influent Samples, Harriman Site, Harriman, New York**

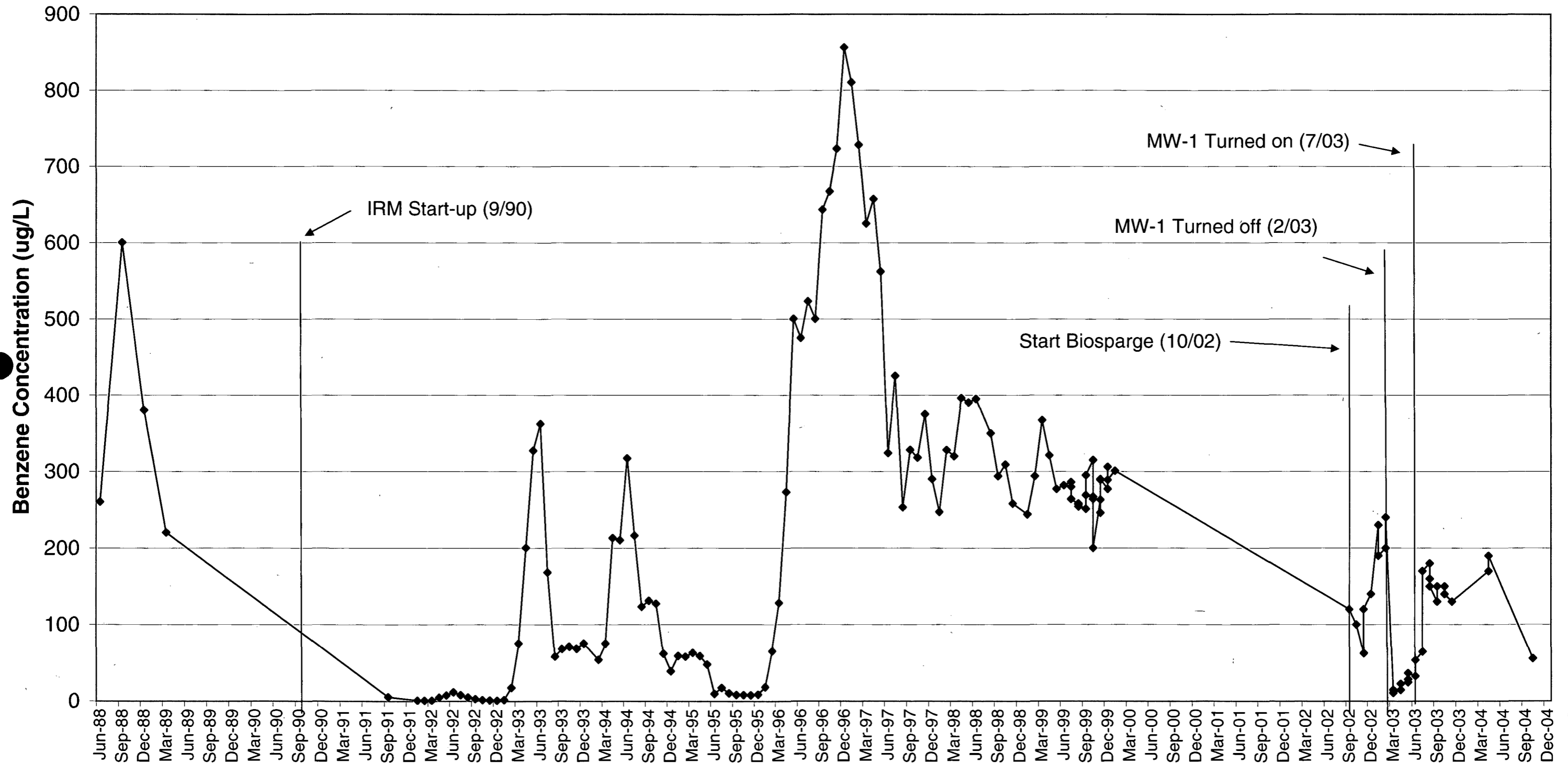

Note: A data gap currently exists for the time period between January 2000 to September 2002.



Appendix A

OW-6 Area Geoprobe Logs and Soil
and Groundwater Analytical Data,
October 2006

Boring Location ID	Sample ID	Sample Matrix	Sample Date	Chemical Name	Concentration	Units
GP-4	BS-1A 14-14.5	Soil	10/12/06	Benzene	9100	UG/KG
GP-4	BS-1A 14-14.5	Soil	10/12/06	Toluene	ND	UG/KG
GP-4	BS-1A 14-14.5	Soil	10/12/06	Chlorobenzene	ND	UG/KG
GP-4	BS-1A 14-14.5	Soil	10/12/06	Ethylbenzene	ND	UG/KG
GP-4	BS-1A 14-14.5	Soil	10/12/06	Xylenes (total)	ND	UG/KG
GP-4	BS-1A 20-24	Groundwater	10/12/06	Benzene	3	UG/L
GP-4	BS-1A 20-24	Groundwater	10/12/06	Toluene	ND	UG/L
GP-4	BS-1A 20-24	Groundwater	10/12/06	Chlorobenzene	ND	UG/L
GP-4	BS-1A 20-24	Groundwater	10/12/06	Ethylbenzene	ND	UG/L
GP-4	BS-1A 20-24	Groundwater	10/12/06	Xylenes (total)	ND	UG/L
GP-5	BS-2A 12-12.5	Soil	10/13/06	Benzene	12000	UG/KG
GP-5	BS-2A 12-12.5	Soil	10/13/06	Toluene	99	UG/KG
GP-5	BS-2A 12-12.5	Soil	10/13/06	Chlorobenzene	ND	UG/KG
GP-5	BS-2A 12-12.5	Soil	10/13/06	Ethylbenzene	ND	UG/KG
GP-5	BS-2A 12-12.5	Soil	10/13/06	Xylenes (total)	ND	UG/KG
GP-5	BS-2A 21-25	Groundwater	10/13/06	Benzene	240	UG/L
GP-5	BS-2A 21-25	Groundwater	10/13/06	Chlorobenzene	ND	UG/L
GP-5	BS-2A 21-25	Groundwater	10/13/06	Ethylbenzene	ND	UG/L
GP-5	BS-2A 21-25	Groundwater	10/13/06	Xylenes (total)	ND	UG/L
GP-6	BS-2B 12-12.5	Soil	10/13/06	Benzene	26000	UG/KG
GP-6	BS-2B 12-12.5	Soil	10/13/06	Toluene	360	UG/KG
GP-6	BS-2B 12-12.5	Soil	10/13/06	Chlorobenzene	ND	UG/KG
GP-6	BS-2B 12-12.5	Soil	10/13/06	Ethylbenzene	ND	UG/KG
GP-6	BS-2B 12-12.5	Soil	10/13/06	Xylenes (total)	ND	UG/KG
GP-8	BS-2D 15-15.5	Soil	10/13/06	Benzene	53000	UG/KG
GP-8	BS-2D 15-15.5	Soil	10/13/06	Toluene	ND	UG/KG
GP-8	BS-2D 15-15.5	Soil	10/13/06	Chlorobenzene	ND	UG/KG
GP-8	BS-2D 15-15.5	Soil	10/13/06	Ethylbenzene	ND	UG/KG
GP-8	BS-2D 15-15.5	Soil	10/13/06	Xylenes (total)	ND	UG/KG
GP-8	BS-2D 21-25	Groundwater	10/13/06	Benzene	420	UG/L
GP-8	BS-2D 21-25	Groundwater	10/13/06	Toluene	ND	UG/L
GP-8	BS-2D 21-25	Groundwater	10/13/06	Chlorobenzene	ND	UG/L
GP-8	BS-2D 21-25	Groundwater	10/13/06	Ethylbenzene	ND	UG/L
GP-8	BS-2D 21-25	Groundwater	10/13/06	Xylenes (total)	ND	UG/L

ARCADIS

Sample/Core Log

Boring/Well GP-1 Project/No. NJ000389.0007.0007 Page 1 of 1

Site Location Harriman, New York Drilling Started 10/12/2006 Drilling Completed 10/12/2006

Total Depth Drilled 30 Feet Hole Diameter 2 inches Type of Sample/
Coring Device Geoprobe

Length and Diameter of Coring Device 5' x 2" Sampling Interval continuous

Land-Surface Elev. _____ feet Surveyed Estimated Datum _____

Drilling Fluid Used NA Drilling Method Direct Push

Drilling Contractor SGS Environmental Drilling Services Driller Mark Helper _____

Prepared By D. Heuer Hammer Weight NA Hammer Drop NA ins.

Sample/Core Depth
(feet below land surface)

From	To	Core Recovery (feet)	Core Interval (feet)	Sample/Core Description	PID
0	5	4	0-1.5	Top Fill (Sand and Gravel), brown.	0
			1.5-2	Clayey SILT, greyish green.	0
			2-3	SILT and SAND, Fine, brown; trace Gravel.	0
			3-3.5	Clayey SILT, greyish brown; trace Sand, Coarse and Gravel, Fine.	0
			3.5-4	SAND, Fine to Coarse, greyish brown; some Gravel; trace Silt	0
5	10	0	NA	Core liner stuck in probe.	
10	15	5	0-5	CLAY; trace Silt, greyish green, wet.	0
15	20	5	0-1	Same as above interval.	0
			1-1.5	Same as above interval grading to Sand, Very fine to Fine, brown.	0
			1.5-5	SAND, Very fine to Fine, brown.	0
20	25	5	0-1	Silty CLAY, brown.	0
			1-2	SILT; trace Sand, Very fine.	0
			2-4	Clayey SILT; trace Sand, Very fine.	0
			4-4.5	CLAY, brown; trace Sand, Coarse.	0
			4.5-5	SAND, Fine to Coarse and GRAVEL, round to subrounded; trace pebble.	0
25	30	5	0-0.5	Same as above interval.	0
			0.5-1	Clayey SILT, brown.	0
			1-2	CLAY, brown; trace Sand, Coarse.	0
			2-5	SAND, Very fine to Fine, brown-grey.	0

ARCADIS Sample/Core Log

Boring/Well GP-2 Project/No. NJ000389.0007.0007 Page 1 of 1

Site Location Harriman, New York Drilling Started 10/12/2006 Drilling Completed 10/12/2006

Total Depth Drilled 25 Feet Hole Diameter 2 inches Type of Sample/ Coring Device Geoprobe

Length and Diameter of Coring Device 5' x 2" Sampling Interval continuous

Land-Surface Elev. feet Surveyed Estimated Datum

Drilling Fluid Used NA Drilling Method Direct Push

Drilling Contractor SGS Environmental Drilling Services Driller Mark Helper

Prepared By D. Heuer Hammer Weight NA Hammer Drop NA ins.

Sample/Core Depth (feet below land surface)

From	To	Core Recovery (feet)	Core Interval (feet)	Sample/Core Description	PID
0	5	4	0-4	Top Fill (Sand and Gravel), brown to grey.	0
5	10	5	0-0.5	Same as above interval.	0
			0.5-4.5	Clayey SILT, brown and greyish green.	0
			4.5-5	Clayey SILT, brown.	0
10	15	5	0-1	Silty CLAY, greyish green.	0
			1-2	Silty CLAY, brown.	0
			2-4	SAND, Very fine to Fine, black-grey; lenses of Clay, brown, 1-2" thick.	0
			4-5	SAND, Fine; trace Medium Sand, brown; distinct Clay seems.	0
15	20	4	0-3	SAND, Fine; trace Medium Sand, brown; bright orange very fine sand/silt at 0.5'; increased percentage of medium sand near 3'.	0
			3-4	SAND, Coarse and GRAVEL, brown, round to subrounded; trace Pebble (quartz and orange shale).	0
20	25	2	0-2	SAND, Fine to Medium, brown; some Gravel; trace Pebble, round to subrounded.	0

ARCADIS

Sample/Core Log

Boring/Well GP-5 Project/No. NJ000389.0007.0007 Page 1 of 1

Site Location Harriman, New York Drilling Started 10/13/2006 Drilling Completed 10/13/2006

Total Depth Drilled 30 Feet Hole Diameter 2 inches Type of Sample/
Coring Device Geoprobe

Length and Diameter of Coring Device 5' x 2" Sampling Interval continuous

Land-Surface Elev. _____ feet Surveyed Estimated Datum _____

Drilling Fluid Used NA Drilling Method Direct Push

Drilling Contractor SGS Environmental Drilling Services Driller Mark Helper _____

Prepared By D. Heuer Hammer Weight NA Hammer Drop NA ins.

Sample/Core Depth

From	To	Core Recovery (feet)	Core Interval (feet)	Sample/Core Description	PID
0	5	4	0-2	Top Fill.	0
			2-4	Clayey SILT, greyish green; trace Sand, Medium to Coarse.	1.6
5	10	5	0-2	Silty SAND, Fine to Coarse; trace Gravel, subround.	0.9
			2-5	Silty CLAY, greyish green.	70
10	15	5	0-0.5	GRAVEL, Fine, rounded to subrounded.	6
			0.5-1	Sandy (Medium to Coarse) CLAY.	22
			1-5	Silty CLAY, greyish green.	264
15	20	5	0-5	CLAY, greyish green, highly plastic.	128
20	25	5	0-1	CLAY, brown; trace Sand (Fine).	6
			1-2	Clayey SAND, Fine.	0
			2-4	SAND, Fine, black-grey-brown.	2
			4-5	Silty/Clayey SAND.	1.2
25	30	5	0-0.25	Clayey SILT, brown.	0
			0.25-4	SAND, Very fine to Fine; trace Silt and Clay, brown.	0
			4-5	Clayey SILT, brown.	0

Soil Sample 12-12.5' - CBTEX.
GW Sample 21-25' - CBTEX.

ARCADIS

Sample/Core Log

Boring/Well GP-6 Project/No. NJ000389.0007.0007 Page 1 of 1

Site Harriman, New York Drilling Started 10/13/2006 Drilling Completed 10/13/2006

Total Depth Drilled 25 Feet Hole Diameter 2 inches Type of Sample/
Coring Device Geoprobe

Length and Diameter of Coring Device 5' x 2" Sampling Interval continuous

Land-Surface Elev. feet Surveyed Estimated Datum

Drilling Fluid Used NA Drilling Method Direct Push

Drilling Contractor SGS Environmental Drilling Services Driller Mark Helper

Prepared By D. Heuer Hammer Weight NA Hammer Drop NA ins.

Sample/Core Depth

From	To	Core Recovery (feet)	Core Interval (feet)	Sample/Core Description	PID
0	5	5	0-2	Top Fill.	168
			2-4.5	Clayey SILT, greenish grey; trace Sand.	22
			4.5-5	Silty SAND, Fine to Coarse; trace Gravel.	1.2
5	10	5	0-1.5	SAND, Medium to Coarse; some Gravel, rounded to subrounded.	3
			1.5-3	SAND, Medium, grey-green.	3
			3-4.5	CLAY, brown, odor present.	165
			4.5-5	CLAY, greenish grey.	70
10	15	5	0-5	CLAY, greenish grey, strong odor present.	222
15	20	5	0-4	Same as above interval.	40
			4-4.5	SAND, Fine to Medium.	78
			4.5-5	CLAY, greenish grey.	20
20	25	5	0-0.5	Same as above interval.	2.2
			0.5-4	SAND, Fine.	3.2
			4-5	SAND, Medium to Coarse; trace Gravel, rounded to subrounded.	1

Soil Sample 12-12.5' - CBTEX.

ARCADIS

Sample/Core Log

Boring/Well GP-7 Project/No. NJ000389.0007.0007 Page 1 of 1

Site Location Harriman, New York Drilling Started 10/13/2006 Drilling Completed 10/13/2006

Total Depth Drilled 25 Feet Hole Diameter 2 inches Type of Sample/
Coring Device Geoprobe

Length and Diameter of Coring Device 5' x 2" Sampling Interval continuous

Land-Surface Elev. _____ feet Surveyed Estimated Datum _____

Drilling Fluid Used NA Drilling Method Direct Push

Drilling Contractor SGS Environmental Drilling Services Driller Mark Helper _____

Prepared By D. Heuer Hammer Weight NA Hammer Drop NA ins.

Sample/Core Depth
(feet below land surface)

From	To	Core Recovery (feet)	Core Interval (feet)	Sample/Core Description	PID
0	5	5	0-2	Top Fill.	3.8
			2-5	Clayey SILT, greenish grey; trace Sand.	0
5	10	5	0-1	SILT, greenish brown.	2.1
			1-2	Clayey SILT, greenish grey; trace Sand.	0
			2-2.5	SAND, Coarse and Gravel, Fine.	0
			2.5-4	SAND, Medium.	0
			4-5	Silty CLAY, brown and dry.	5
10	15	5	0-0.5	SAND, Coarse.	0
			0.5-5	Silty CLAY, greyish green.	132
15	20	5	0-3	Same as above interval.	16
			3-4	Clayey SAND, Fine, brown-grey.	9
			4-4.5	Silty CLAY, brown.	0
			4.5-5	SAND, Fine, grey-black.	1.2
20	25	4	0-4	SAND, Fine to Medium; Gravel/Coarse Sand lense 2" thick	0
				at 0.5' interval.	

ARCADIS

Sample/Core Log

Boring/Well GP-8 Project/No. NJ000389.0007.0007 Page 1 of 1

Site Location Harriman, New York Drilling Started 10/13/2006 Drilling Completed 10/13/2006

Total Depth Drilled 25 Feet Hole Diameter 2 inches Type of Sample/
Coring Device Geoprobe

Length and Diameter of Coring Device 5' x 2" Sampling Interval continuous

Land-Surface Elev. _____ feet Surveyed Estimated Datum _____

Drilling Fluid Used NA Drilling Method Direct Push

Drilling Contractor SGS Environmental Drilling Services Driller Mark Helper _____

Prepared By D. Heuer Hammer Weight NA Hammer Drop NA ins.

Sample/Core Depth
(feet below land surface)

From	To	Core Recovery (feet)	Core Interval (feet)	Sample/Core Description	PID
0	5	5	0-3	Top Fill.	21
			3-4	SILT, trace Sand and Gravel, greyish green.	0
			4-5	SAND, Medium to Coarse and GRAVEL.	0
5	10	5	0-1	SAND, Fine to Medium; trace Coarse Sand, blackish grey.	1.1
			1-5	Silty CLAY, brown to green.	38
10	15	5	0-5	Silty CLAY, greyish green, strong odor present.	262
15	20	5	0-5	Silty CLAY, greyish green, strong odor present; Fine Sand	407
				near bottom of core.	
20	25	5	0-1	Clayey SAND, Medium, greyish green.	2.4
			1-5	SAND, Fine; trace Silt, brown.	0

Soil Sample 15-15.5' - CBTEX.
GW Sample 21-25' - CBTEX.



APPENDIX B



Appendix B

Historical Groundwater Quality Data

Table 3: Summary of Field Parameters and Analytical Data, Biosparge Remediation System, Harriman Site, Harriman, NY.

SpCond (µS/cm)	RW-1S	MW-8S	MW-17S	MW-16S	MW-15S	OW-6	OW-7	MW-25S	MW-26S	MW-26D	PZ-4	MW-6D	MW-7S	MW-20S	MW-20D	MW-33	MW-34	MW-53D	MW-28S	MW-29S	MW-24	RW1R	MW-1S	MW-5S	MW-11S	MW-12S	MW-35S	MW-37S
11/15/00	1280	1300	1020	912	921	955	1030	496	2660	41800	2060	50300	849	1100	1470													
12/04/01	1109	1149	948.1	935.6	770.1	809.4	1198	768.1	2948	311	3640	624.5	913.5	1127	2643													
12/27/01	1079	1165	874.1	969.1	878	(11-650)	(870-1028)	881.1	-	-	-	-	-	-	-													
01/29/02	-	1156	1257	959.2	1332	234.8	703.3	887.2	-	-	-	-	-	-	-													
02/04/02	834	913	1186	822	1057	594	596	566	-	-	-	-	-	-	-													
04/09/02	1013	1080	988	958	1390	851	702	719	-	-	-	-	-	-	-													
06/03/02	1033	1096	1016	902	1372	755	755	729	2771	282	2584	598	825	2377	1015													
07/09/02	-	1312	1316	1100	1416	992	985	905	-	-	-	-	-	-	-													
08/08/02	800	1286	1163	1054	1236	1017	897	917	-	-	-	-	-	-	-													
10/02/02	-	905.2	816.0	756.1	866.2	657.0	588.6	563.1	-	-	-	-	-	-	-													
10/14/02	757	914	647	759.3	858	752	550	472	-	-	-	-	-	-	-													
12/18/02	-	1185	756	859	830	1045	933	741	977	277	2235	501	893	2572	1089													
12/26/02	-	1241	749.4	953.3	923.3	1036	977.4	765.4	-	-	-	-	-	-	-													
01/21/03	-	-	463.4	695.4	703.1	760.7	697.3	626.3	-	-	-	-	-	-	-													
02/03/03	1266	1637	655	1198	1113	1131	1116	820	-	-	-	-	-	-	-													
03/04/03	-	914.7	472.0	665.7	770.1	712.3	761.7	510.5	783.9	-	-	-	-	2231	-													
04/03/03	1026	1153	662	863	1144	916	868	732	-	-	-	-	-	-	-													
06/09/03	1080	1238	963	946	960	900	863	862	1086	306	1412	436	897	3113	1528													
08/05/03	1189	1250	1131	947	1017	1157	984	891	-	-	-	-	-	-	-													
10/01/03	1716	1967	1409	1399	1413	1398	1373	1294	-	-	-	-	-	-	-													
12/12/03	946	1234	616	1005	1040	909	864	795	1017	318	1561	427	945	2898	1467													
March 2004	1382	1508	838	1040	1139	1123	972	752	NA	NA	NA	NA	NA	NA	24464	12370	1406	NA	NA	NA	NA	NA						
June 2004	1148	1221	1117	996	1070	918	863	724	1840	305	994	377	976	1161	1654	17458	9347	1196	NA	NA	NA	NA	NA					
September 2004	NA	1329	1536	985	1008	1018	1240	829	NA	NA	NA	NA	NA	NA	29499	11971	1319	NA	NA	NA	NA	NA	NA					
January 2005	NA	1345	595	1008	833	754	844	617	1667	315	500	359	825	4744	1932	25266	9609	1203	NA	NA	NA	NA	NA					
July 2005	NA	1.906	1.046	1.198	0.888	1.133	0.912	0.97	2.221	0.328	0.572	0.407	1.062	4.337	3.527	15.7	18.05	1.34	1.728	0.636	3.534	NA						
January 2006	NA	1355	381	1009	443	884	767	800	982	318	481	349	945	1720	2826	14807	6990	1204	1285	287	2313	1181						
June 2006	NA	1431	498	1058	744	907	810	918	1300	387	574	374	1096	1331	2622	14553	8525	1409	1583	0.627	3002	961	1738	548	1405	225	1627	1513
July 2006	NA	NA	NA	NA	NA	NA	NA	NA	NA	NA	NA	NA	NA	NA	NA	NA	NA	NA	NA	NA	NA	1061	1670	NA	NA	NA	NA	NA
January 2007	NA	1448	NA	1055	NA	968	757	858	NA	369	NA	361	155	1966	2932	NA	NA	1135	NA	NA	2565	954	1358	NA	NA	192	NA	NA
DTW (feet)																												
11/15/00	-	8.10	6.39	17.40	17.00	12.06	12.47	-	8.36	7.82	16.02	10.10	7.90	6.68	0.08													
12/04/01	-	14.10	8.11	21.20	8.73	19.12	19.06	19.88	8.54	10.72	20.44	13.91	11.03	11.94	1.12													
12/27/01	-	11.60	7.08	18.99	7.84	16.10	22.70	18.90	-	-	-	-	-	-	-													
01/29/02	-	10.26	5.40	18.04	6.72	19.98	18.08	18.20	-	-	-	-	-	-	-													
02/04/02	-	10.74	6.02	18.16	6.88	17.64	18.44	18.98	-	-	-	-	-	-	-													
04/09/02	-	9.76	5.60	17.74	6.74	15.11	15.52	16.28	-	-	-	-	-	-	-													
06/03/02	-	5.39	4.81	11.90	5.71	8.29	8.60	9.40	8.10	5.10	13.50	6.95	6.28	6.08	32.65													
07/09/02	-	5.70	4.88	12.40	5.00	9.46	9.80	10.67	-	-	-	-	-	-	-													
08/08/02	-	7.98	5.91	15.20	6.26	12.86	13.10	13.87	-	-	-	-	-	-	-													
10/14/02	-	7.60	4.82	14.98	5.10	13.80	13.84	14.26	-	-	-	-	-	-	-													
12/18/02	-	3.02	3.18	9.00	4.00	5.16	5.12	6.21	7.06	4.18	10.50	5.66	4.80	3.90	16.34													
12/26/02	-	2.08	3.41	8.95	3.75	4.94	5.83	6.10	-	-	-	-	-	-	-													
01/21/03	-	-	3.78	9.18	4.47	5.26	5.60	5.88	-	-	-	-	-	-	-													
02/03/03	-	3.91	4.02	10.01	5.16	7.02	8.37	8.80	-	-	-	-	-	-	-													
03/04/03	-	2.26	3.06	9.18	3.68	5.74	5.98	6.90	7.26	-	-	-	-	5.37	-													
04/03/03	-	1.68	3.42	8.39	3.95	3.98	5.14	6.66	-	-	-	-	-	-	-													
06/09/03	-	2.62	3.77	9.14	4.56	8.29	5.64	6.68	7.31	4.72	12.37	7.41	4.83	1.00	2.20													
08/05/03	-	4.52	3.95	11.54	5.02	8.00	8.33	9.80	-	-	-	-	-	-	-													
10/01/03	-	4.88	4.31	10.64	5.09	6.99	7.29	8.30	-	-	-	-	-	-	-													
12/12/03	6.40	2.60	3.89	-	3.60	3.98	4.95	6.86	3.31	11.89	4.76	4.13	1.63	5.10														
March 2004	--	3.50	4.11	10.45	6.80	7.34	8.24	9.96	NA	NA	NA	NA	NA	NA	8.98	6.52	7.21	NA	NA	NA	NA	NA						
June 2004	--	4.59	4.73	10.68	7.90	8.70	8.94	11.89	8.13	36.3	39.75	11.4	5.91	4.45	7.66	10.38	5.00	7.97	NA	NA	NA	NA						
September 2004	NA	2.70	3.86	9.75	5.40	6.55	7.78	9.84	NA	NA	NA	NA	NA	NA	9.82	7.41	6.39	NA	NA	NA	NA	NA						
January 2005	NA	2.90	3.80	9.82	6.24	5.75	6.74	8.51	7.73	14.71	31.49	8.28	5.03	6.40	15.10	4.97	4.90	5.49	NA	NA	NA	NA						
July 2005	NA	5.11	4.25	12.45	5.04	NA	9.95	12.48	8.04	NA	12.9	10.42	6.56	3.85	2	7.67	8.74	9.26	8.7	8.18	NA							
January 2006	NA	1.33	3.4	8.21	4.58	3.83	5.51	6.51	7.02	5.36	29.8	6.51	4.2	1.16	3.5	6.83	4.53	4.28	7.9	7.6	7.5	4.35						
June 2006	NA	4.15	4.01	11.22	6	6.99	8.29	9.18	6.99	8.51	37.82	10.8	5.65	6.82	4.05	9.8	5.61	6.58	7.19	8.55	7.19	6.05	5.57	12.63	4.48	16.45	3.1	1.92
July 2006	NA	NA	NA	NA	NA	NA	NA	NA	NA	NA	NA	NA	NA	NA	NA	NA	NA	NA	NA	NA	NA	6.5	7.51	NA	NA	NA	NA	NA
January 2007	NA	3.35	NA	10.87	NA	8.1	8.52	8.73	NA	4.82	NA	8.1	5.55	3.55	1.6	NA	NA	7.23	NA	NA	8.14	6.31	7.4	NA	NA	7.11	NA	NA

Table 3: Summary of Field Parameters and Analytical Data, Biosparge Remediation System, Harriman Site, Harriman, NY.

	RW-1S	MW-8S	MW-17S	MW-16S	MW-15S	OW-6	OW-7	MW-25S	MW-26S	MW-26D	PZ-4	MW-6D	MW-7S	MW-20S	MW-20D	MW-33	MW-34	MW-53D	MW-28S	MW-29S	MW-24	RW1R	MW-1S	MW-5S	MW-11S	MW-12S	MW-35S	MW-37S	
Xylenes, total (ppb)																													
11/15/00	ND	ND	ND	ND	ND	ND	ND	ND	ND	ND	2	ND	ND	ND	4									ND	ND	1	J		
12/04/01	ND	ND	ND	ND	2	ND	< 25	ND	ND	ND	4	ND	ND	ND	2														
02/04/02	ND	ND	ND	ND	ND	ND	ND	0.2	-	-	-	-	-	-	-														
04/09/02	ND	ND	ND	ND	ND	ND	ND	ND	-	-	-	-	-	-	-														
06/03/02	ND	ND	ND	ND	ND	ND	ND	ND	ND	ND	2	ND	ND	ND	0.8														
08/08/02	ND	ND	1	ND	ND	ND	ND	ND	-	-	-	-	-	-	-														
10/14/02	ND	ND	ND	ND	ND	ND	ND	ND	-	-	-	-	-	-	-														
12/17/02	-	ND	1	J	ND	4	J	ND	ND	ND	4	J	ND	ND	-	-													
02/03/03	ND	ND	ND	ND	ND	ND	ND	ND	-	-	-	-	-	-	-														
04/03/03	ND	ND	ND	ND	1	J	ND	ND	-	-	-	-	-	-	-														
06/09/03	ND	ND	ND	ND	ND	ND	ND	ND	ND	ND	2	J	ND	ND	3	J													
08/05/03	ND	ND	ND	ND	ND	ND	ND	ND	-	-	-	-	-	-	-														
10/01/03	ND	ND	1	J	ND	ND	ND	ND	ND	-	-	-	-	-	-														
12/12/03	ND	ND	ND	ND	ND	ND	ND	ND	ND	ND	3	J	ND	ND	ND	ND													
March 2004	ND	ND	ND	ND	ND	ND	ND	ND	NA	NA	NA	NA	NA	NA	2	J	ND	ND	NA	NA	NA	NA	NA						
June 2004	ND	ND	ND	ND	ND	ND	ND	ND	ND	ND	2	J	ND	ND	5	J	5	J	ND	NA	NA	NA	NA						
September 2004	NA	ND	ND	ND	ND	ND	ND	ND	NA	NA	NA	NA	NA	NA	4	J	ND	NA	NA	NA	NA	NA							
January 2005	NA	ND	ND	ND	ND	ND	ND	ND	ND	ND	1	J	ND	ND	3	J	5	J	ND	NA	NA	NA	NA						
July 2005	NA	ND	ND	ND	ND	ND	ND	ND	ND	ND	2	J	ND	ND	0.9	ND	J	4	J	3	J	0.9	ND	ND	ND	ND	NA		
January 2006	NA	ND	ND	ND	ND	ND	ND	ND	ND	ND	1	J	ND	ND	5	J	5	J	7	J	ND	ND	ND	ND	ND				
June 2006	NA	ND	ND	ND	ND	ND	ND	ND	ND	ND	ND	ND	ND	5	J	ND	5	J	ND	ND	ND	ND	ND	ND	ND	ND	ND	ND	ND
July 2006	NA	NA	NA	NA	NA	NA	NA	NA	NA	NA	NA	NA	NA	NA	NA	NA	NA	NA	NA	NA	NA	NA	NA	NA	NA	NA	NA	NA	NA
January 2007	ND			1		ND	ND	ND		ND	ND	ND	ND	6				ND				ND	ND	ND		ND			
Chlorobenzene (ppb)																													
11/15/00	0.9	ND	ND	ND	0.4	ND	ND	ND	6	ND	0.3	ND	ND	ND	ND									ND	ND	ND			
12/04/01	0.8	ND	ND	ND	0.7	ND	< 25	ND	7	ND	0.9	ND	ND	0.7	ND														
02/04/02	ND	ND	ND	ND	ND	ND	ND	ND	-	-	-	-	-	-	-														
04/09/02	ND	ND	ND	ND	ND	ND	ND	ND	-	-	-	-	-	-	-														
06/03/02	ND	ND	ND	ND	ND	ND	ND	ND	4	ND	0.5	ND	ND	2	ND														
08/08/02	ND	ND	0.7	ND	ND	ND	ND	ND	-	-	-	-	-	-	-														
10/14/02	ND	ND	ND	ND	ND	ND	ND	ND	-	-	-	-	-	-	-														
12/17/02	-	ND	ND	ND	ND	ND	ND	ND	ND	ND	0.8	J	ND	ND	-	-													
02/03/03	ND	ND	ND	ND	ND	ND	ND	ND	-	-	-	-	-	-	-														
04/03/03	ND	ND	ND	ND	ND	ND	ND	ND	-	-	-	-	-	-	-														
06/09/03	ND	ND	0.4	J	ND	ND	ND	ND	ND	ND	ND	ND	ND	10	J	ND													
08/05/03	ND	ND	ND	ND	ND	ND	ND	ND	-	-	-	-	-	-	-														
10/01/03	ND	ND	ND	ND	ND	ND	ND	ND	-	-	-	-	-	-	-														
12/12/03	ND	ND	ND	ND	ND	ND	ND	ND	ND	ND	0.6	J	ND	ND	9	J	1	J											
March 2004	ND	ND	ND	ND	ND	ND	ND	ND	NA	NA	NA	NA	NA	NA	NA	ND	ND	ND	NA	NA	NA	NA	NA						
June 2004	ND	ND	ND	ND	ND	ND	ND	ND	ND	ND	0.5	J	ND	ND	1	J	ND	ND	ND	NA	NA	NA	NA						
September 2004	NA	ND	ND	ND	ND	ND	ND	ND	NA	NA	NA	NA	NA	NA	NA	ND	ND	ND	NA	NA	NA	NA							
January 2005	NA	ND	ND	ND	ND	ND	ND	ND	ND	ND	ND	ND	ND	ND	1	J	ND	ND	ND	NA	NA	NA	NA						
July 2005	NA	ND	ND	ND	ND	ND	ND	ND	3	ND	ND	ND	ND	0.6	ND	J	ND	ND	ND	ND	ND	ND	ND	NA					
January 2006	NA	ND	ND	ND	ND	ND	ND	ND	ND	ND	ND	ND	ND	ND	2	J	ND	ND	ND	ND	ND	ND	ND	ND					
June 2006	NA	NA	NA	NA	NA	NA	NA	NA	NA	NA	NA	NA	NA	NA	NA	NA	NA	NA	NA	NA	NA	NA	NA	NA	NA	NA	NA	NA	NA
July 2006	NA	NA	NA	NA	NA	NA	NA	NA	NA	NA	NA	NA	NA	NA	NA	NA	NA	NA	NA	NA	NA	NA	NA	NA	NA	NA	NA	NA	NA
January 2007	ND			ND		ND	ND	ND		ND	ND	ND	ND	2	2			ND				ND	ND	ND		ND			

Table 3: Summary of Field Parameters and Analytical Data, Biosparge Remediation System, Harriman Site, Harriman, NY.

	RW-1S	MW-8S	MW-17S	MW-16S	MW-15S	OW-6	OW-7	MW-25S	MW-26S	MW-26D	PZ-4	MW-6D	MW-7S	MW-20S	MW-20D	MW-33	MW-34	MW-53D	MW-28S	MW-29S	MW-24	RW1R	MW-1S	MW-5S	MW-11S	MW-12S	MW-35S	MW-37S	
Pyridine (ppb)																													
11/15/00	ND	ND	ND	ND	ND	1400	330	14	ND	ND	2	ND	ND	23	5										ND	ND	ND		
12/04/01	ND	ND	ND	ND	ND	60	< 460	ND	ND	ND	9	ND	ND	< 92	ND														
02/04/02	ND	ND	ND	ND	ND	ND	ND	ND	-	-	-	-	-	-	-														
04/09/02	ND	ND	ND	ND	ND	840	ND	ND	-	-	-	-	-	-	-														
06/03/02	ND	ND	ND	ND	ND	42	ND	ND	ND	ND	10	ND	ND	ND	27														
08/08/02	ND	ND	ND	ND	ND	360	ND	ND	-	-	-	-	-	-	-														
10/14/02	ND	ND	ND	ND	ND	28	ND	12	-	-	-	-	-	-	-														
12/17/02	-	ND	ND	ND	ND	49	17	J	ND	ND	ND	ND	ND	-	-														
02/03/03	ND	ND	ND	ND	ND	170	12	ND	-	-	-	-	-	-	-														
04/03/03	ND	ND	ND	ND	ND	290	7	J	ND	-	-	-	-	-	-														
06/09/03	ND	ND	ND	ND	ND	ND	46	ND	ND	ND	ND	ND	ND	ND	270	J													
08/05/03	ND	ND	ND	ND	ND	ND	ND	ND	-	-	-	-	-	-	-														
10/01/03	ND	ND	550	ND	ND	ND	ND	ND	-	-	-	-	-	-	-														
12/12/03	ND	ND	ND	ND	ND	ND	ND	ND	ND	ND	ND	ND	ND	ND	200	J													
March 2004	ND	10	J	ND	ND	ND	53	ND	ND	NA	NA	NA	NA	NA	NA	ND	ND	ND	NA	NA	NA	NA							
June 2004	ND	ND	ND	ND	ND	88	ND	ND	ND	ND	ND	ND	ND	ND	280	35	ND	ND	NA	NA	NA	NA							
September 2004	NA	ND	ND	ND	ND	ND	ND	ND	NA	NA	NA	NA	NA	NA	NA	18	J	ND	ND	NA	NA	NA	NA						
January 2005	NA	ND	ND	ND	ND	46	J	5	J	ND	100	ND	ND	ND	ND	270	J	51	ND	ND	NA	NA	NA	NA					
July 2005	NA	ND	ND	ND	ND	390	J	ND	J	ND	ND	ND	ND	ND	8	280	J	3	ND	ND	ND	ND	ND	NA					
January 2006	NA	ND	ND	ND	ND	ND	ND	ND	ND	ND	ND	ND	ND	ND	280	J	ND	ND	ND	ND	ND	ND	ND						
June 2006	NA	ND	ND	ND	ND	86	4	J	ND	ND	ND	3	J	ND	ND	12	J	170	J	42	25	J	ND	ND	ND	ND	ND	ND	ND
July 2006	NA	NA	NA	NA	NA	NA	NA	NA	NA	NA	NA	NA	NA	NA	NA	NA	NA	NA	NA	NA	NA	NA	NA	NA	NA	NA	NA	NA	NA
January 2007	ND	ND	NA	NA	NA	NA	NA	NA	ND	ND	NA	ND	ND	NA	NA			NA	NA	NA	ND	ND	ND			NA			
alpha-picoline (ppb)																													
11/15/00	11	ND	ND	250	ND	3900	640	300	ND	ND	7	ND	ND	86	17										ND	ND	1	J	
12/04/01	13	4	ND	240	ND	24	3400	250	ND	ND	15	ND	ND	170	26														
02/04/02	3	ND	ND	79	ND	170	9	190	-	-	-	-	-	-	-														
04/09/02	ND	ND	ND	93	ND	620	43	39	-	-	-	-	-	-	-														
06/03/02	4	2	ND	100	ND	84	28	42	ND	ND	22	ND	ND	250	28														
08/08/02	2	ND	ND	32	ND	770	21	6	-	-	-	-	-	-	-														
10/14/02	ND	ND	ND	37	ND	63	9	62	-	-	-	-	-	-	-														
12/17/02	-	ND	ND	ND	ND	ND	ND	ND	ND	ND	ND	ND	ND	-	-														
02/03/03	ND	ND	27	13	ND	180	23	9	-	-	-	-	-	-	-														
04/03/03	ND	ND	4	J	85	ND	390	66	-	-	-	-	-	-	-														
06/09/03	ND	ND	2	J	130	ND	1100	76	40	ND	ND	9	J	ND	ND	660	J	220											
08/05/03	ND	ND	ND	130	ND	8700	15	11	-	-	-	-	-	-	-														
10/01/03	ND	ND	ND	110	ND	490	300	23	-	-	-	-	-	-	-														
12/12/03	ND	ND	ND	82	ND	71	140	2	J	ND	ND	5	J	ND	ND	770	J	140	J										
March 2004	ND	10	ND	60	ND	890	150	110	NA	NA	NA	NA	NA	NA	NA	53	ND	3	J	NA	NA	NA	NA						
June 2004	ND	ND	ND	57	ND	470	76	16	ND	ND	0.7	J	ND	ND	11	200	44	ND	3	J	NA	NA	NA	NA					
September 2004	NA	ND	ND	71	ND	820	27	40	NA	NA	NA	NA	NA	NA	NA	21	1700	3	J	NA	NA	NA	NA						
January 2005	NA	ND	ND	65	ND	660	18	2	J	4	J	ND	ND	9	J	200	32	1200	3	J	NA	NA	NA	NA					
July 2005	NA	ND	ND	79	ND	2700	8	29	J	ND	J	ND	ND	31	J	210	2	2300	4	J	ND	ND	ND	NA					
January 2006	NA	ND	ND	210	ND	76	10	42	ND	ND	6	J	ND	ND	13	210	J	ND	420	6	J	ND	ND	ND					
June 2006	NA	ND	ND	230	ND	1300	37	J	74	ND	ND	5	J	ND	ND	44	120	J	29	840	5	J	ND	ND	ND	ND	ND	ND	ND
July 2006	NA	NA	NA	NA	NA	NA	NA	NA	NA	NA	NA	NA	NA	NA	NA	NA	NA	NA	NA	NA	NA	NA	NA	NA	NA	NA	NA	NA	NA
January 2007	ND	ND	NA	NA	NA	NA	NA	NA	ND	ND	NA	ND	ND	NA	NA			NA	NA	NA	ND	ND	ND			NA			
2-amino-pyridine (ppb)																													
11/15/00	2	8	ND	ND	ND	ND	ND	ND	ND	ND	5	ND	ND	390	31										ND	1	J	3	J
12/04/01	4	6	2	5	3	ND	< 100	ND	ND	ND	13	ND	ND	980	140														
02/04/02	2	ND	3	ND	2	ND	ND	ND	-	-	-	-	-	-	-														
04/09/02	ND	ND	ND	ND	ND	ND	ND	ND	-	-	-	-	-	-	-														
06/03/02	2	7	ND	ND	1	ND	ND	ND	ND	ND	ND	ND	ND	1400	160														
08/08/02	3	ND	1	ND	ND	ND	ND	ND	-	-	-	-	-	-	-														
10/14/02	ND	1	ND	ND	ND	ND	ND	ND	-	-	-	-	-	-	-														
12/17/02	-	ND	2	J	ND	ND	ND	ND	ND	ND	3	J	ND	ND	-	-													
02/03/03	ND	ND	ND	ND	ND	ND	ND	ND	-	-	-	-	-	-	-														
04/03/03	ND	ND	ND	ND	ND	ND	ND	ND	-	-	-	-	-	-	-														
06/09/03	ND	ND	1	J	ND	ND	ND	ND	ND	ND	6	J	ND	ND	4300	970													
08/05/03	ND	ND	ND	ND	ND	ND	ND	ND	-	-	-	-	-	-	-														
10/01/03	6	J	ND	ND	ND	ND	ND	ND	-	-	-	-																	

Table 3: Summary of Field Parameters and Analytical Data, Biosparge Remediation System, Harriman Site, Harriman, NY.

	RW-1S	MW-8S	MW-17S	MW-16S	MW-15S	OW-6	OW-7	MW-25S	MW-26S	MW-26D	PZ-4	MW-6D	MW-7S	MW-20S	MW-20D	MW-33	MW-34	MW-53D	MW-28S	MW-29S	MW-24	RW1R	MW-1S	MW-5S	MW-11S	MW-12S	MW-35S	MW-37S	
Mercury																													
July 2005	NA	NA	NA	NA	NA	NA	NA	NA	NA	NA	NA	NA	NA	NA	NA	NA	NA	NA	0.21	ND	0.24	NA							
January 2006	NA	NA	NA	NA	NA	NA	NA	NA	NA	NA	NA	NA	NA	NA	NA	NA	NA	NA	NA	NA	NA	NA							
June 2006	NA	NA	NA	NA	NA	NA	NA	NA	NA	NA	NA	NA	NA	NA	NA	NA	NA	NA	0.16	ND	0.3	NA	NA	NA	NA	NA	NA	NA	
January 2007	NA	NA	NA	NA	NA	NA	NA	NA	NA	NA	NA	NA	NA	NA	NA	NA	NA	NA	NA	NA	NA	NA	NA	NA	NA	NA	NA	NA	
Mercury, diss.																													
July 2005	NA	NA	NA	NA	NA	NA	NA	NA	NA	NA	NA	NA	NA	NA	NA	NA	NA	NA	0.2	B	ND	0.31	NA						
January 2006	NA	NA	NA	NA	NA	NA	NA	NA	NA	NA	NA	NA	NA	NA	NA	NA	NA	NA	NA	NA	NA	NA							
June 2006	NA	NA	NA	NA	NA	NA	NA	NA	NA	NA	NA	NA	NA	NA	NA	NA	NA	NA	NA	NA	NA	NA	NA	NA	NA	NA	NA	NA	
January 2007	NA	NA	NA	NA	NA	NA	NA	NA	NA	NA	NA	NA	NA	NA	NA	NA	NA	NA	NA	NA	NA	NA	NA	NA	NA	NA	NA	NA	
Ammonia (mg/L)																													
June 2006	NA	20	NA	22	NA	7.1	4.2	4.7	9.1	0.025	5.8	ND	0.025	20	39	1900	NA	35	41	0.048	1.1	1.2	61	1.5	16	1.6	25	46	
Biogeochemical																													
TOC (mg/L)																													
June 2006	NA	ND	NA	34	NA	330	120	110	NA	NA	NA	NA	NA	24	NA	NA	NA	6.6	NA	NA	4.1	2.3	NA	NA	NA	NA	NA	NA	
Iron (Total, ug/L)																													
June 2006	NA	6900	NA	5220	NA	11300	12500	3220	NA	NA	NA	NA	NA	1630	NA	NA	NA	5800	NA	NA	409	13100	NA	NA	NA	NA	NA	NA	
Iron (Dissolved, ug/L)																													
June 2006	NA	5630	NA	5570	NA	10700	12300	3050	NA	NA	NA	NA	NA	1340	NA	NA	NA	5620	NA	NA	362	8300	NA	NA	NA	NA	NA	NA	
Manganese (Total, mg/L)																													
June 2006	NA	418	NA	805	NA	1770	3770	914	NA	NA	NA	NA	NA	312	NA	NA	NA	339	NA	NA	459	651	NA	NA	NA	NA	NA	NA	
Manganese (Dissolved, mg/L)																													
June 2006	NA	431	NA	807	NA	1770	3760	940	NA	NA	NA	NA	NA	311	NA	NA	NA	340	NA	NA	464	669	NA	NA	NA	NA	NA	NA	
Sulfate (mg/L)																													
June 2006	NA	44.7	NA	1	NA	0.926	22.2	2.08	NA	NA	NA	NA	NA	46.7	NA	NA	NA	0.295	NA	NA	841	42.9	NA	NA	NA	NA	NA	NA	
Nitrate (mg/L)																													
June 2006	NA	ND	NA	0.077	NA	ND	0.068	ND	NA	NA	NA	NA	NA	ND	NA	NA	NA	ND	NA	NA	0.142	0.031	NA	NA	NA	NA	NA	NA	
Alkalinity (mg/L)																													
June 2006	NA	422	NA	353	NA	429	303	338	NA	NA	NA	NA	NA	326	NA	NA	NA	373	NA	NA	301	202	NA	NA	NA	NA	NA	NA	

NOTES:

- Data recorded on 11/15/00 was prior to start up of the biosparge pilot test.
- Data recorded on 12/04/01 was prior to the expanded biosparge system start-up.
- RW-1S is a pumping well.
- * High water level in MW-20D is suspected to be run-off from surface due to a leaking seal.
- ** DO value high due to aeration in the well. Initial pressure in well 1-1.5 psi.
- *** Redox is suspect to be high due to meter malfunction even though field calibration okay.
- () A range of values was recorded because the parameter would not stabilize due to aeration in the well.
- J - Estimated value.
- DTW - Depth to water from top of well casing.
- ND - Not detected above the method detection limit.
- Results in Bold indicate that value is above the standards, criteria and guidance values of NYS
- Well not sample this round, this well is part of the baseline & semi-annual rounds only

NY standards
 VOC - 5 ppb
 SVOC - 50 ppb



APPENDIX C



Appendix C

Mann-Kendall Test

MAROS Mann-Kendall Statistics Summary

Project: Harriman

User Name: DH

Location: Harriman

State: New York

Time Period: 9/1/2004 to 1/1/2007

Consolidation Period: No Time Consolidation

Consolidation Type: Median

Duplicate Consolidation: Average

ND Values: 1/2 Detection Limit

J Flag Values : Actual Value

Well	Source/ Tail	Number of Samples	Number of Detects	Coefficient of Variation	Mann-Kendall Statistic	Confidence in Trend	All Samples "ND" ?	Concentration Trend
2-PICOLINE (ALPHA-PICOLINE)								
MW-33	S	5	4	0.88	-2	59.2%	No	S
OW-7	S	5	5	0.61	0	40.8%	No	S
MW-25S	S	5	5	0.69	6	88.3%	No	NT
OW-6	S	5	5	0.89	0	40.8%	No	S
MW-20D	T	4	4	0.24	-1	50.0%	No	S
MW-20S	T	4	4	0.67	4	83.3%	No	NT
MW-16S	T	5	5	0.62	8	95.8%	No	I
MW-8S	T	6	0	0.00	0	42.3%	Yes	S
MW-53D	T	5	5	0.31	7	92.1%	No	PI
BENZENE								
MW-25S	S	6	6	0.83	3	64.0%	No	NT
MW-33	S	5	5	1.75	0	40.8%	No	NT
OW-7	S	6	6	1.46	3	64.0%	No	NT
OW-6	S	6	6	0.77	4	70.3%	No	NT
MW-20S	T	5	5	1.09	4	75.8%	No	NT
MW-16S	T	6	6	0.50	-13	99.2%	No	D
MW-8S	T	6	3	1.38	-12	98.2%	No	D
MW-20D	T	5	5	0.19	8	95.8%	No	I
MW-53D	T	6	6	0.41	-1	50.0%	No	S
PYRIDINE								
MW-33	S	5	4	0.99	-2	59.2%	No	S
OW-6	S	5	3	1.56	3	67.5%	No	NT
MW-25S	S	5	0	0.00	0	40.8%	Yes	S
OW-7	S	5	2	1.06	1	50.0%	No	NT
MW-8S	T	6	0	0.00	0	42.3%	Yes	S
MW-20D	T	4	4	0.21	-1	50.0%	No	S
MW-53D	T	5	0	0.00	0	40.8%	Yes	S
MW-16S	T	5	0	0.00	0	40.8%	Yes	S
MW-20S	T	4	2	1.09	3	72.9%	No	NT

Note: Increasing (I); Probably Increasing (PI); Stable (S); Probably Decreasing (PD); Decreasing (D); No Trend (NT); Not Applicable (N/A)-
Due to insufficient Data (< 4 sampling events); Source/Tail (S/T)

The Number of Samples and Number of Detects shown above are post-consolidation values.

MAROS Consolidated Data Summary

Well: MW-8S
 Well Type: T
 COC: BENZENE

Time Period: 4/1/1989 to 1/1/2007
 Consolidation Period: No Time Consolidation
 Consolidation Type: Median
 Duplicate Consolidation: Average
 ND Values: 1/2 Detection Limit
 J Flag Values : Actual Value

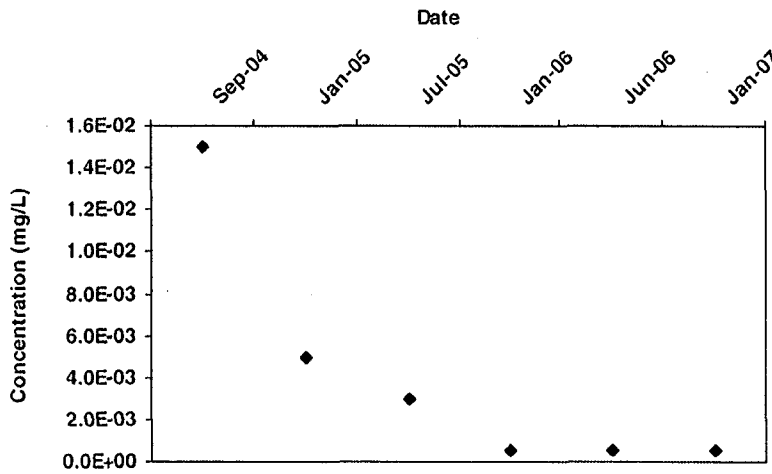

Consolidation Data Table:

Well	Well Type	Consolidation Date	Constituent	Result (mg/L)	Flag	Number of Samples	Number of Detects
MW-8S	T	9/1/2004	BENZENE	1.5E-02		1	1
MW-8S	T	1/1/2005	BENZENE	5.0E-03		1	1
MW-8S	T	7/1/2005	BENZENE	3.0E-03		1	1
MW-8S	T	1/1/2006	BENZENE	5.0E-04	ND	1	0
MW-8S	T	6/1/2006	BENZENE	5.0E-04	ND	1	0
MW-8S	T	1/1/2007	BENZENE	5.0E-04	ND	1	0

MAROS Consolidated Data Summary

Well: MW-8S
 Well Type: T
 COC: PYRIDINE

Time Period: 4/1/1989 to 1/1/2007
 Consolidation Period: No Time Consolidation
 Consolidation Type: Median
 Duplicate Consolidation: Average
 ND Values: 1/2 Detection Limit
 J Flag Values : Actual Value

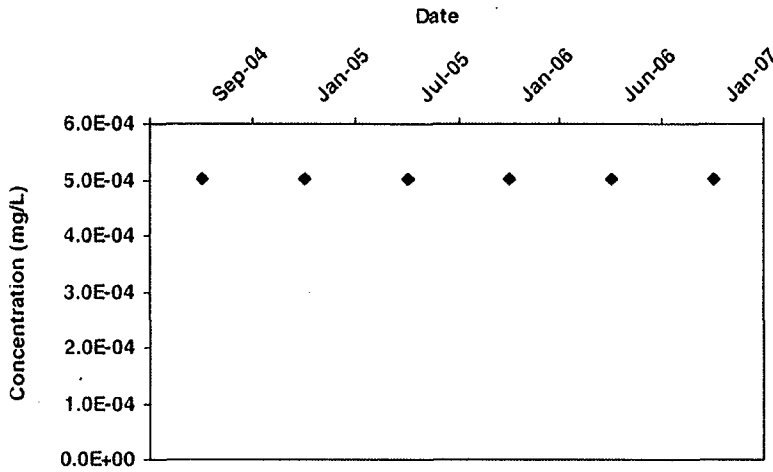

Consolidation Data Table:

Well	Well Type	Consolidation Date	Constituent	Result (mg/L)	Flag	Number of Samples	Number of Detects
MW-8S	T	9/1/2004	PYRIDINE	5.0E-04	ND	1	0
MW-8S	T	1/1/2005	PYRIDINE	5.0E-04	ND	1	0
MW-8S	T	7/1/2005	PYRIDINE	5.0E-04	ND	1	0
MW-8S	T	1/1/2006	PYRIDINE	5.0E-04	ND	1	0
MW-8S	T	6/1/2006	PYRIDINE	5.0E-04	ND	1	0
MW-8S	T	1/1/2007	PYRIDINE	5.0E-04	ND	1	0

MAROS Consolidated Data Summary

Well: MW-8S
 Well Type: T
 COC: 2-PICOLINE (ALPHA-PICOLINE)

Time Period: 4/1/1989 to 1/1/2007
 Consolidation Period: No Time Consolidation
 Consolidation Type: Median
 Duplicate Consolidation: Average
 ND Values: 1/2 Detection Limit
 J Flag Values : Actual Value

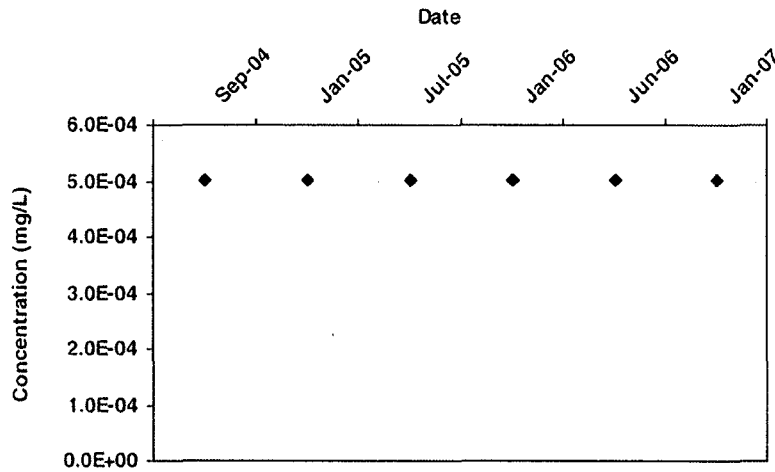

Consolidation Data Table:

Well	Well Type	Consolidation Date	Constituent	Result (mg/L)	Flag	Number of Samples	Number of Detects
MW-8S	T	9/1/2004	2-PICOLINE (ALPHA-PICOLINE)	5.0E-04	ND	1	0
MW-8S	T	1/1/2005	2-PICOLINE (ALPHA-PICOLINE)	5.0E-04	ND	1	0
MW-8S	T	7/1/2005	2-PICOLINE (ALPHA-PICOLINE)	5.0E-04	ND	1	0
MW-8S	T	1/1/2006	2-PICOLINE (ALPHA-PICOLINE)	5.0E-04	ND	1	0
MW-8S	T	6/1/2006	2-PICOLINE (ALPHA-PICOLINE)	5.0E-04	ND	1	0
MW-8S	T	1/1/2007	2-PICOLINE (ALPHA-PICOLINE)	5.0E-04	ND	1	0

MAROS Consolidated Data Summary

Well: MW-16S
 Well Type: T
 COC: BENZENE

Time Period: 4/1/1989 to 1/1/2007
 Consolidation Period: No Time Consolidation
 Consolidation Type: Median
 Duplicate Consolidation: Average
 ND Values: 1/2 Detection Limit
 J Flag Values : Actual Value

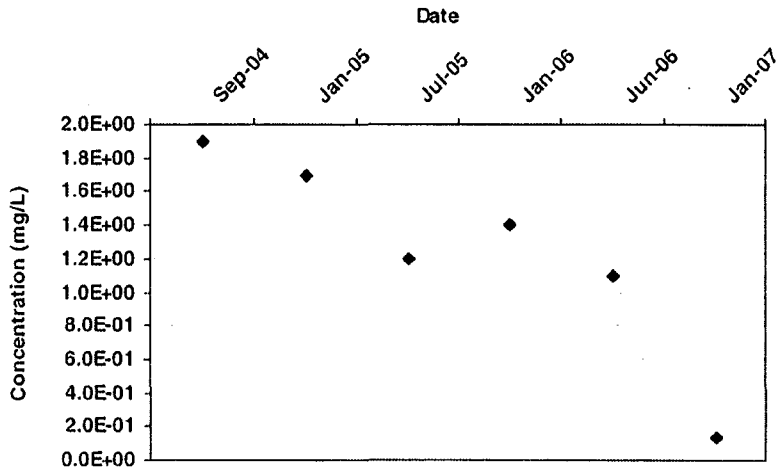

Consolidation Data Table:

Well	Well Type	Consolidation Date	Constituent	Result (mg/L)	Flag	Number of Samples	Number of Detects
MW-16S	T	9/1/2004	BENZENE	1.9E+00		1	1
MW-16S	T	1/1/2005	BENZENE	1.7E+00		1	1
MW-16S	T	7/1/2005	BENZENE	1.2E+00		1	1
MW-16S	T	1/1/2006	BENZENE	1.4E+00		1	1
MW-16S	T	6/1/2006	BENZENE	1.1E+00		1	1
MW-16S	T	1/1/2007	BENZENE	1.3E-01		1	1

MAROS Consolidated Data Summary

Well: MW-16S
 Well Type: T
 COC: PYRIDINE

Time Period: 4/1/1989 to 1/1/2007
 Consolidation Period: No Time Consolidation
 Consolidation Type: Median
 Duplicate Consolidation: Average
 ND Values: 1/2 Detection Limit
 J Flag Values : Actual Value

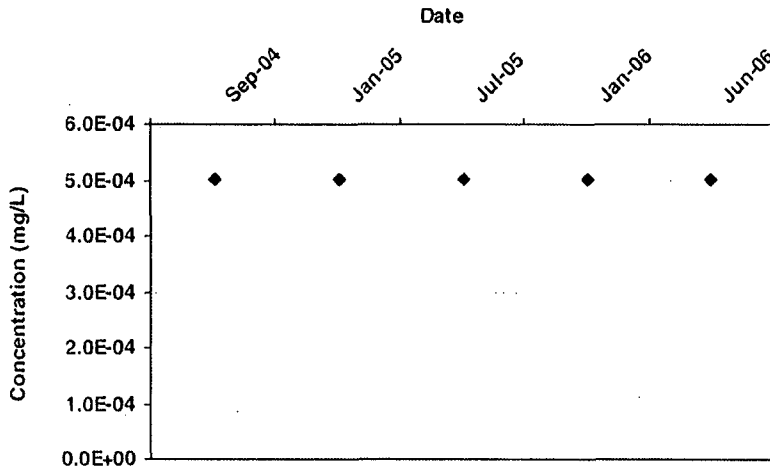

Consolidation Data Table:

Well	Well Type	Consolidation Date	Constituent	Result (mg/L)	Flag	Number of Samples	Number of Detects
MW-16S	T	9/1/2004	PYRIDINE	5.0E-04	ND	1	0
MW-16S	T	1/1/2005	PYRIDINE	5.0E-04	ND	1	0
MW-16S	T	7/1/2005	PYRIDINE	5.0E-04	ND	1	0
MW-16S	T	1/1/2006	PYRIDINE	5.0E-04	ND	1	0
MW-16S	T	6/1/2006	PYRIDINE	5.0E-04	ND	1	0

MAROS Consolidated Data Summary

Well: MW-16S
 Well Type: T
 COC: 2-PICOLINE (ALPHA-PICOLINE)

Time Period: 4/1/1989 to 1/1/2007
 Consolidation Period: No Time Consolidation
 Consolidation Type: Median
 Duplicate Consolidation: Average
 ND Values: 1/2 Detection Limit
 J Flag Values : Actual Value

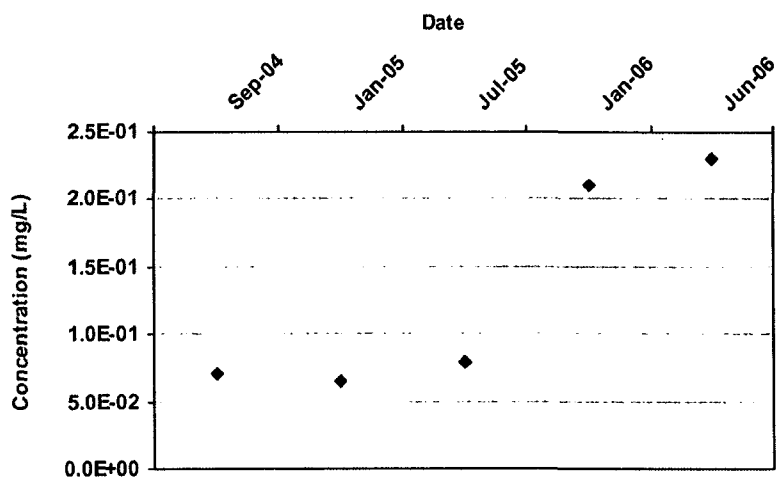

Consolidation Data Table:

Well	Well Type	Consolidation Date	Constituent	Result (mg/L)	Flag	Number of Samples	Number of Detects
MW-16S	T	9/1/2004	2-PICOLINE (ALPHA-PICOLINE)	7.1E-02		1	1
MW-16S	T	1/1/2005	2-PICOLINE (ALPHA-PICOLINE)	6.5E-02		1	1
MW-16S	T	7/1/2005	2-PICOLINE (ALPHA-PICOLINE)	7.9E-02		1	1
MW-16S	T	1/1/2006	2-PICOLINE (ALPHA-PICOLINE)	2.1E-01		1	1
MW-16S	T	6/1/2006	2-PICOLINE (ALPHA-PICOLINE)	2.3E-01		1	1

MAROS Consolidated Data Summary

Well: MW-20S
 Well Type: T
 COC: BENZENE

Time Period: 4/1/1989 to 1/1/2007
 Consolidation Period: No Time Consolidation
 Consolidation Type: Median
 Duplicate Consolidation: Average
 ND Values: 1/2 Detection Limit
 J Flag Values : Actual Value

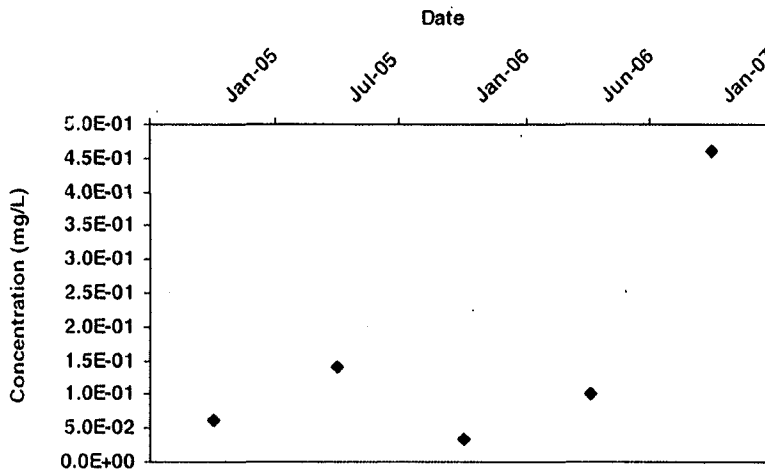

Consolidation Data Table:

Well	Well Type	Consolidation Date	Constituent	Result (mg/L)	Flag	Number of Samples	Number of Detects
MW-20S	T	1/1/2005	BENZENE	6.3E-02		1	1
MW-20S	T	7/1/2005	BENZENE	1.4E-01		1	1
MW-20S	T	1/1/2006	BENZENE	3.3E-02		1	1
MW-20S	T	6/1/2006	BENZENE	1.0E-01		1	1
MW-20S	T	1/1/2007	BENZENE	4.6E-01		1	1

MAROS Consolidated Data Summary

Well: MW-20S
 Well Type: T
 COC: PYRIDINE

Time Period: 4/1/1989 to 1/1/2007
 Consolidation Period: No Time Consolidation
 Consolidation Type: Median
 Duplicate Consolidation: Average
 ND Values: 1/2 Detection Limit
 J Flag Values : Actual Value

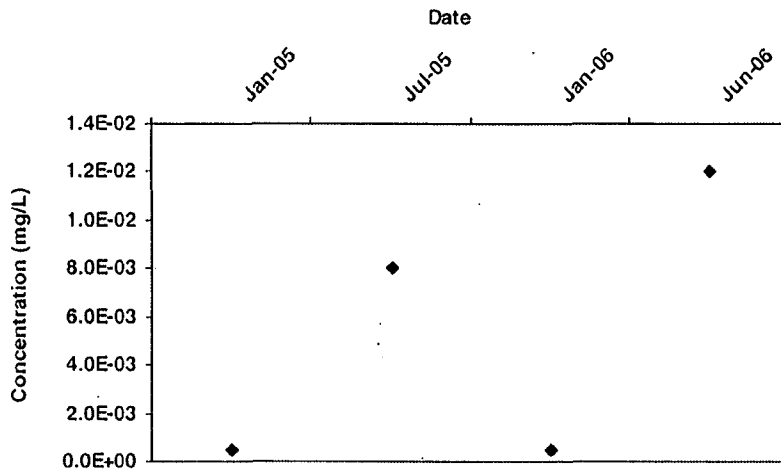

Consolidation Data Table:

Well	Well Type	Consolidation Date	Constituent	Result (mg/L)	Flag	Number of Samples	Number of Detects
MW-20S	T	1/1/2005	PYRIDINE	5.0E-04	ND	1	0
MW-20S	T	7/1/2005	PYRIDINE	8.0E-03		1	1
MW-20S	T	1/1/2006	PYRIDINE	5.0E-04	ND	1	0
MW-20S	T	6/1/2006	PYRIDINE	1.2E-02		1	1

MAROS Consolidated Data Summary

Well: MW-20S
 Well Type: T
 COC: 2-PICOLINE (ALPHA-PICOLINE)

Time Period: 4/1/1989 to 1/1/2007
 Consolidation Period: No Time Consolidation
 Consolidation Type: Median
 Duplicate Consolidation: Average
 ND Values: 1/2 Detection Limit
 J Flag Values : Actual Value

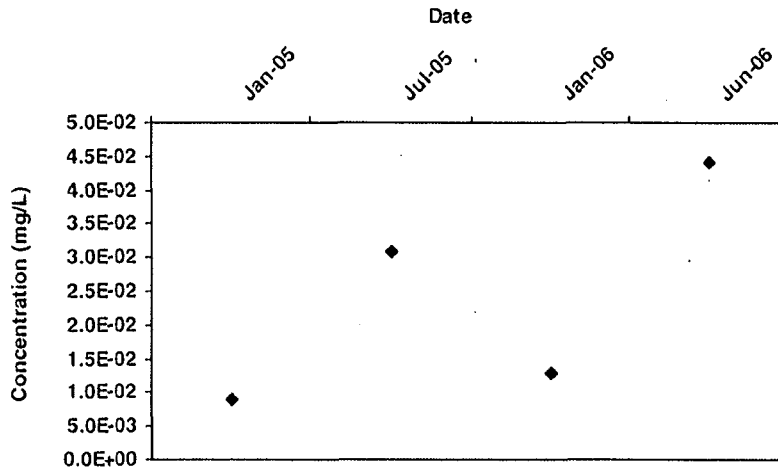

Consolidation Data Table:

Well	Well Type	Consolidation Date	Constituent	Result (mg/L)	Flag	Number of Samples	Number of Detects
MW-20S	T	1/1/2005	2-PICOLINE (ALPHA-PICOLINE)	9.0E-03		1	1
MW-20S	T	7/1/2005	2-PICOLINE (ALPHA-PICOLINE)	3.1E-02		1	1
MW-20S	T	1/1/2006	2-PICOLINE (ALPHA-PICOLINE)	1.3E-02		1	1
MW-20S	T	6/1/2006	2-PICOLINE (ALPHA-PICOLINE)	4.4E-02		1	1

MAROS Consolidated Data Summary

Well: MW-20D
 Well Type: T
 COC: BENZENE

Time Period: 9/1/2004 to 1/1/2007
 Consolidation Period: No Time Consolidation
 Consolidation Type: Median
 Duplicate Consolidation: Average
 ND Values: 1/2 Detection Limit
 J Flag Values : Actual Value

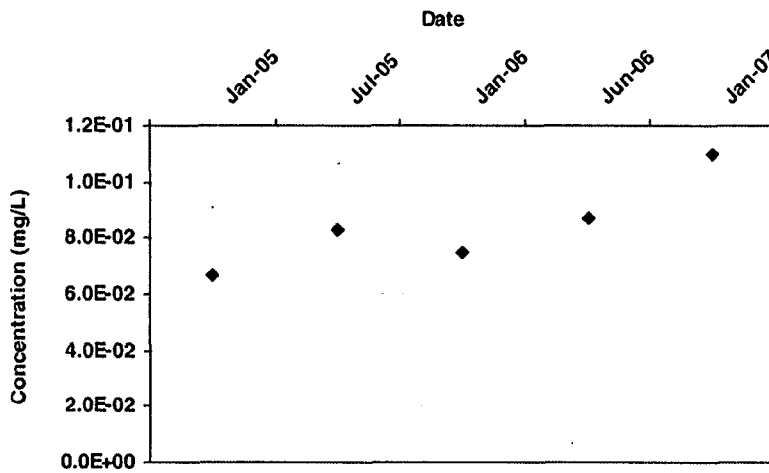

Consolidation Data Table:

Well	Well Type	Consolidation Date	Constituent	Result (mg/L)	Flag	Number of Samples	Number of Detects
MW-20D	T	1/1/2005	BENZENE	6.7E-02		1	1
MW-20D	T	7/1/2005	BENZENE	8.3E-02		1	1
MW-20D	T	1/1/2006	BENZENE	7.5E-02		1	1
MW-20D	T	6/1/2006	BENZENE	8.7E-02		1	1
MW-20D	T	1/1/2007	BENZENE	1.1E-01		1	1

MAROS Consolidated Data Summary

Well: MW-20D
 Well Type: T
 COC: PYRIDINE

Time Period: 9/1/2004 to 1/1/2007
 Consolidation Period: No Time Consolidation
 Consolidation Type: Median
 Duplicate Consolidation: Average
 ND Values: 1/2 Detection Limit
 J Flag Values : Actual Value

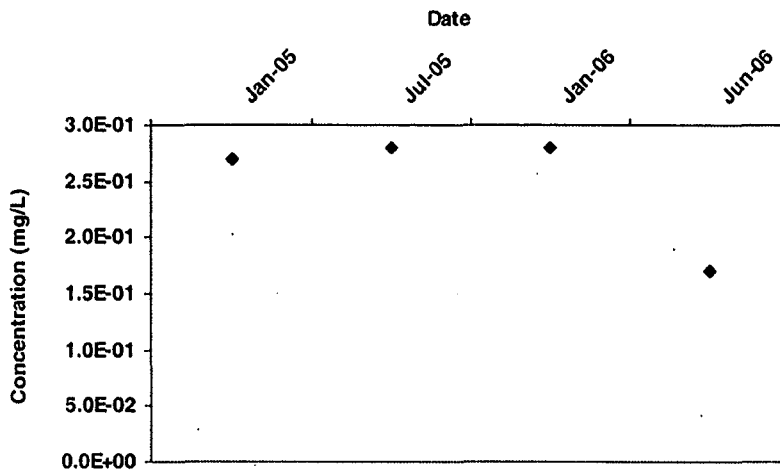

Consolidation Data Table:

Well	Well Type	Consolidation Date	Constituent	Result (mg/L)	Flag	Number of Samples	Number of Detects
MW-20D	T	1/1/2005	PYRIDINE	2.7E-01		1	1
MW-20D	T	7/1/2005	PYRIDINE	2.8E-01		1	1
MW-20D	T	1/1/2006	PYRIDINE	2.8E-01		1	1
MW-20D	T	6/1/2006	PYRIDINE	1.7E-01		1	1

MAROS Consolidated Data Summary

Well: MW-20D
 Well Type: T
 COC: 2-PICOLINE (ALPHA-PICOLINE)

Time Period: 9/1/2004 to 1/1/2007
 Consolidation Period: No Time Consolidation
 Consolidation Type: Median
 Duplicate Consolidation: Average
 ND Values: 1/2 Detection Limit
 J Flag Values : Actual Value

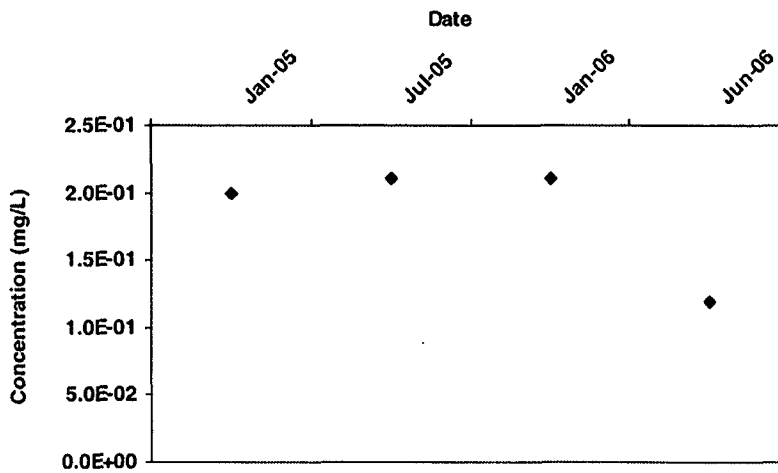

Consolidation Data Table:

Well	Well Type	Consolidation Date	Constituent	Result (mg/L)	Flag	Number of Samples	Number of Detects
MW-20D	T	1/1/2005	2-PICOLINE (ALPHA-PICOLINE)	2.0E-01		1	1
MW-20D	T	7/1/2005	2-PICOLINE (ALPHA-PICOLINE)	2.1E-01		1	1
MW-20D	T	1/1/2006	2-PICOLINE (ALPHA-PICOLINE)	2.1E-01		1	1
MW-20D	T	6/1/2006	2-PICOLINE (ALPHA-PICOLINE)	1.2E-01		1	1

MAROS Consolidated Data Summary

Well: MW-25S
 Well Type: T
 COC: BENZENE

Time Period: 4/1/1989 to 1/1/2007
 Consolidation Period: No Time Consolidation
 Consolidation Type: Median
 Duplicate Consolidation: Average
 ND Values: 1/2 Detection Limit
 J Flag Values : Actual Value

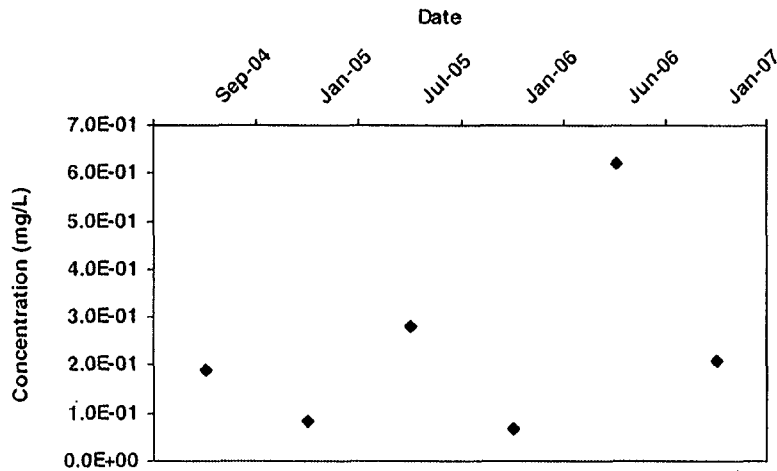

Consolidation Data Table:

Well	Well Type	Consolidation Date	Constituent	Result (mg/L)	Flag	Number of Samples	Number of Detects
MW-25S	T	9/1/2004	BENZENE	1.9E-01		1	1
MW-25S	T	1/1/2005	BENZENE	8.5E-02		1	1
MW-25S	T	7/1/2005	BENZENE	2.8E-01		1	1
MW-25S	T	1/1/2006	BENZENE	6.6E-02		1	1
MW-25S	T	6/1/2006	BENZENE	6.2E-01		1	1
MW-25S	T	1/1/2007	BENZENE	2.1E-01		1	1

MAROS Consolidated Data Summary

Well: MW-25S
 Well Type: T
 COC: PYRIDINE

Time Period: 4/1/1989 to 1/1/2007
 Consolidation Period: No Time Consolidation
 Consolidation Type: Median
 Duplicate Consolidation: Average
 ND Values: 1/2 Detection Limit
 J Flag Values : Actual Value

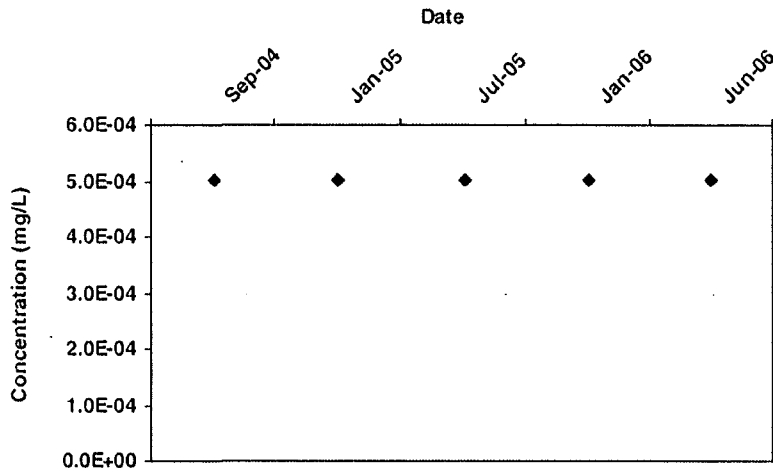

Consolidation Data Table:

Well	Well Type	Consolidation Date	Constituent	Result (mg/L)	Flag	Number of Samples	Number of Detects
MW-25S	T	9/1/2004	PYRIDINE	5.0E-04	ND	1	0
MW-25S	T	1/1/2005	PYRIDINE	5.0E-04	ND	1	0
MW-25S	T	7/1/2005	PYRIDINE	5.0E-04	ND	1	0
MW-25S	T	1/1/2006	PYRIDINE	5.0E-04	ND	1	0
MW-25S	T	6/1/2006	PYRIDINE	5.0E-04	ND	1	0

MAROS Consolidated Data Summary

Well: MW-25S
 Well Type: T
 COC: 2-PICOLINE (ALPHA-PICOLINE)

Time Period: 4/1/1989 to 1/1/2007
 Consolidation Period: No Time Consolidation
 Consolidation Type: Median
 Duplicate Consolidation: Average
 ND Values: 1/2 Detection Limit
 J Flag Values : Actual Value

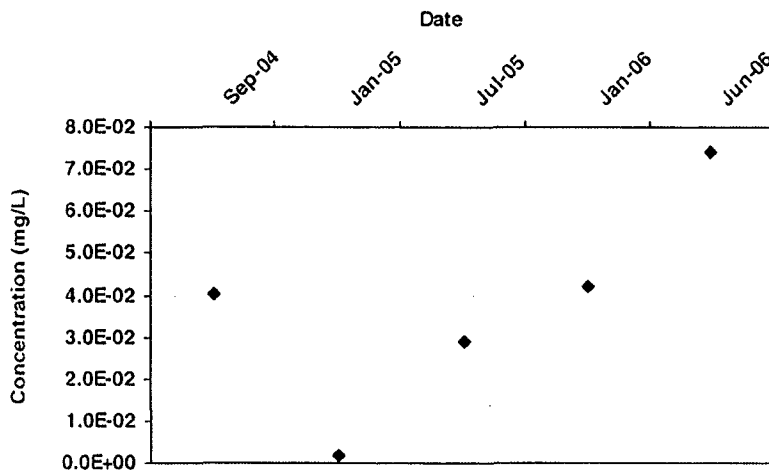

Consolidation Data Table:

Well	Well Type	Consolidation Date	Constituent	Result (mg/L)	Flag	Number of Samples	Number of Detects
MW-25S	T	9/1/2004	2-PICOLINE (ALPHA-PICOLINE)	4.0E-02		1	1
MW-25S	T	1/1/2005	2-PICOLINE (ALPHA-PICOLINE)	2.0E-03		1	1
MW-25S	T	7/1/2005	2-PICOLINE (ALPHA-PICOLINE)	2.9E-02		1	1
MW-25S	T	1/1/2006	2-PICOLINE (ALPHA-PICOLINE)	4.2E-02		1	1
MW-25S	T	6/1/2006	2-PICOLINE (ALPHA-PICOLINE)	7.4E-02		1	1

MAROS Consolidated Data Summary

Well: MW-33
 Well Type: S
 COC: BENZENE

Time Period: 4/1/1989 to 1/1/2007
 Consolidation Period: No Time Consolidation
 Consolidation Type: Median
 Duplicate Consolidation: Average
 ND Values: 1/2 Detection Limit
 J Flag Values : Actual Value

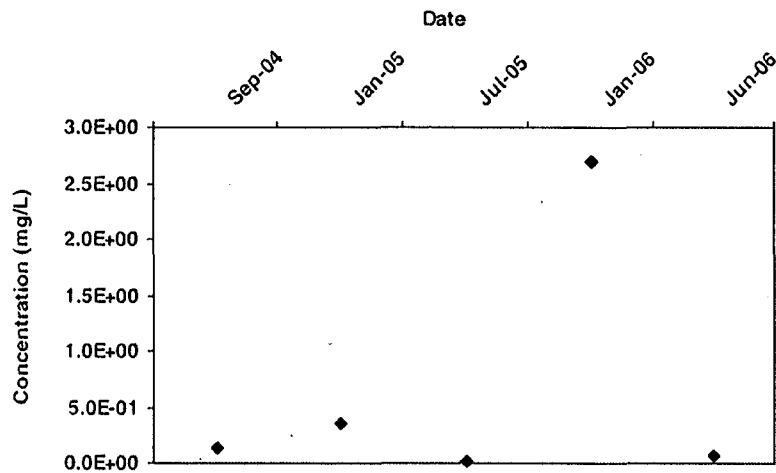

Consolidation Data Table:

Well	Well Type	Consolidation Date	Constituent	Result (mg/L)	Flag	Number of Samples	Number of Detects
MW-33	S	9/1/2004	BENZENE	1.3E-01		1	1
MW-33	S	1/1/2005	BENZENE	3.5E-01		1	1
MW-33	S	7/1/2005	BENZENE	2.4E-02		1	1
MW-33	S	1/1/2006	BENZENE	2.7E+00		1	1
MW-33	S	6/1/2006	BENZENE	7.4E-02		1	1

MAROS Consolidated Data Summary

Well: MW-33
 Well Type: S
 COC: PYRIDINE

Time Period: 9/1/2004 to 1/1/2007
 Consolidation Period: No Time Consolidation
 Consolidation Type: Median
 Duplicate Consolidation: Average
 ND Values: 1/2 Detection Limit
 J Flag Values : Actual Value

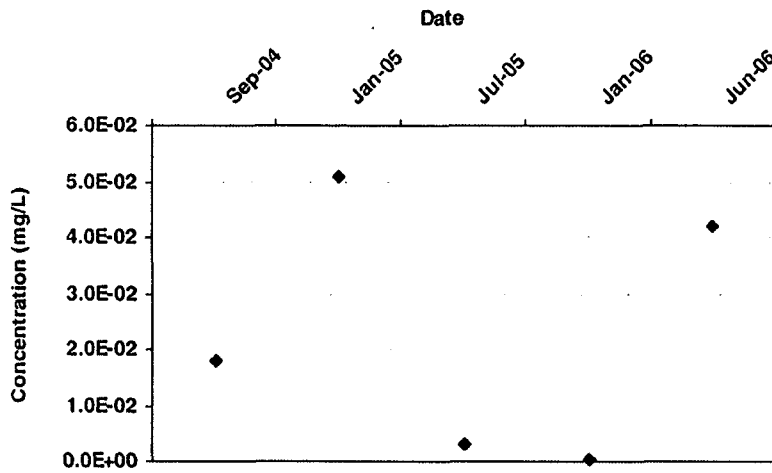

Consolidation Data Table:

Well	Well Type	Consolidation Date	Constituent	Result (mg/L)	Flag	Number of Samples	Number of Detects
MW-33	S	9/1/2004	PYRIDINE	1.8E-02		1	1
MW-33	S	1/1/2005	PYRIDINE	5.1E-02		1	1
MW-33	S	7/1/2005	PYRIDINE	3.0E-03		1	1
MW-33	S	1/1/2006	PYRIDINE	5.0E-04	ND	1	0
MW-33	S	6/1/2006	PYRIDINE	4.2E-02		1	1

MAROS Consolidated Data Summary

Well: MW-33
 Well Type: S
 COC: 2-PICOLINE (ALPHA-PICOLINE)

Time Period: 9/1/2004 to 1/1/2007
 Consolidation Period: No Time Consolidation
 Consolidation Type: Median
 Duplicate Consolidation: Average
 ND Values: 1/2 Detection Limit
 J Flag Values : Actual Value

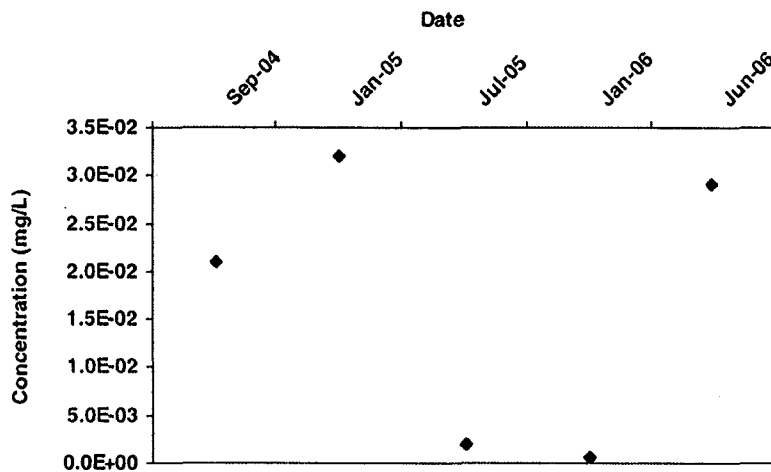

Consolidation Data Table:

Well	Well Type	Consolidation Date	Constituent	Result (mg/L)	Flag	Number of Samples	Number of Detects
MW-33	S	9/1/2004	2-PICOLINE (ALPHA-PICOLINE)	2.1E-02		1	1
MW-33	S	1/1/2005	2-PICOLINE (ALPHA-PICOLINE)	3.2E-02		1	1
MW-33	S	7/1/2005	2-PICOLINE (ALPHA-PICOLINE)	2.0E-03		1	1
MW-33	S	1/1/2006	2-PICOLINE (ALPHA-PICOLINE)	5.0E-04	ND	1	0
MW-33	S	6/1/2006	2-PICOLINE (ALPHA-PICOLINE)	2.9E-02		1	1

MAROS Consolidated Data Summary

Well: MW-53D
 Well Type: T
 COC: BENZENE

Time Period: 4/1/1989 to 1/1/2007
 Consolidation Period: No Time Consolidation
 Consolidation Type: Median
 Duplicate Consolidation: Average
 ND Values: 1/2 Detection Limit
 J Flag Values : Actual Value

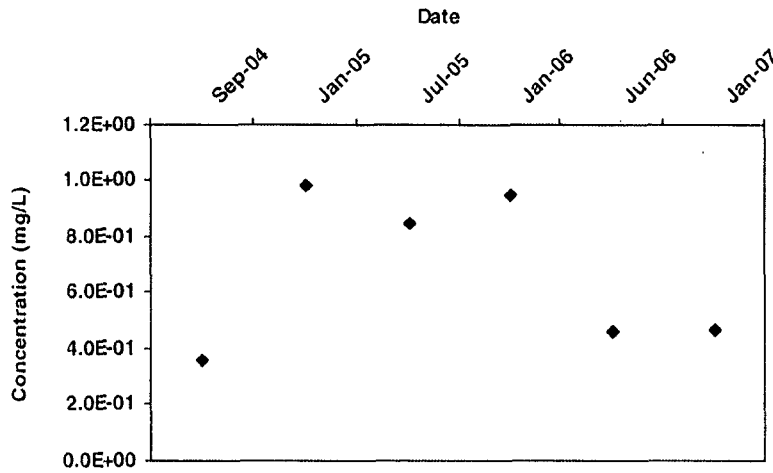

Consolidation Data Table:

Well	Well Type	Consolidation Date	Constituent	Result (mg/L)	Flag	Number of Samples	Number of Detects
MW-53D	T	9/1/2004	BENZENE	3.6E-01		1	1
MW-53D	T	1/1/2005	BENZENE	9.8E-01		1	1
MW-53D	T	7/1/2005	BENZENE	8.5E-01		1	1
MW-53D	T	1/1/2006	BENZENE	9.5E-01		1	1
MW-53D	T	6/1/2006	BENZENE	4.6E-01		1	1
MW-53D	T	1/1/2007	BENZENE	4.7E-01		1	1

MAROS Consolidated Data Summary

Well: MW-53D
 Well Type: T
 COC: PYRIDINE

Time Period: 4/1/1989 to 1/1/2007
 Consolidation Period: No Time Consolidation
 Consolidation Type: Median
 Duplicate Consolidation: Average
 ND Values: 1/2 Detection Limit
 J Flag Values : Actual Value

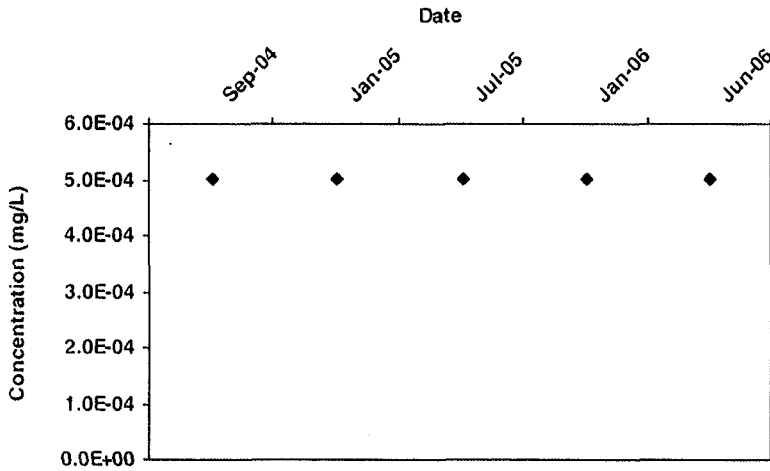

Consolidation Data Table:

Well	Well Type	Consolidation Date	Constituent	Result (mg/L)	Flag	Number of Samples	Number of Detects
MW-53D	T	9/1/2004	PYRIDINE	5.0E-04	ND	1	0
MW-53D	T	1/1/2005	PYRIDINE	5.0E-04	ND	1	0
MW-53D	T	7/1/2005	PYRIDINE	5.0E-04	ND	1	0
MW-53D	T	1/1/2006	PYRIDINE	5.0E-04	ND	1	0
MW-53D	T	6/1/2006	PYRIDINE	5.0E-04	ND	1	0

MAROS Consolidated Data Summary

Well: MW-53D
 Well Type: T
 COC: 2-PICOLINE (ALPHA-PICOLINE)

Time Period: 4/1/1989 to 1/1/2007
 Consolidation Period: No Time Consolidation
 Consolidation Type: Median
 Duplicate Consolidation: Average
 ND Values: 1/2 Detection Limit
 J Flag Values : Actual Value

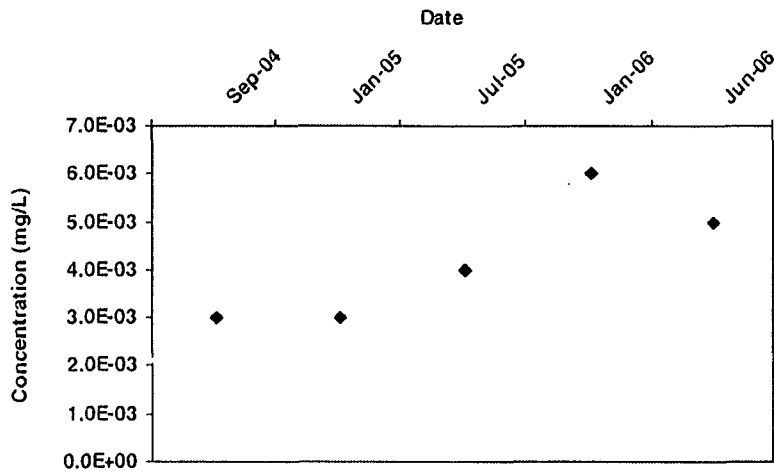

Consolidation Data Table:

Well	Well Type	Consolidation Date	Constituent	Result (mg/L)	Flag	Number of Samples	Number of Detects
MW-53D	T	9/1/2004	2-PICOLINE (ALPHA-PICOLINE)	3.0E-03		1	1
MW-53D	T	1/1/2005	2-PICOLINE (ALPHA-PICOLINE)	3.0E-03		1	1
MW-53D	T	7/1/2005	2-PICOLINE (ALPHA-PICOLINE)	4.0E-03		1	1
MW-53D	T	1/1/2006	2-PICOLINE (ALPHA-PICOLINE)	6.0E-03		1	1
MW-53D	T	6/1/2006	2-PICOLINE (ALPHA-PICOLINE)	5.0E-03		1	1

MAROS Consolidated Data Summary

Well: OW-6
 Well Type: S
 COC: BENZENE

Time Period: 4/1/1989 to 1/1/2007
 Consolidation Period: No Time Consolidation
 Consolidation Type: Median
 Duplicate Consolidation: Average
 ND Values: 1/2 Detection Limit
 J Flag Values : Actual Value

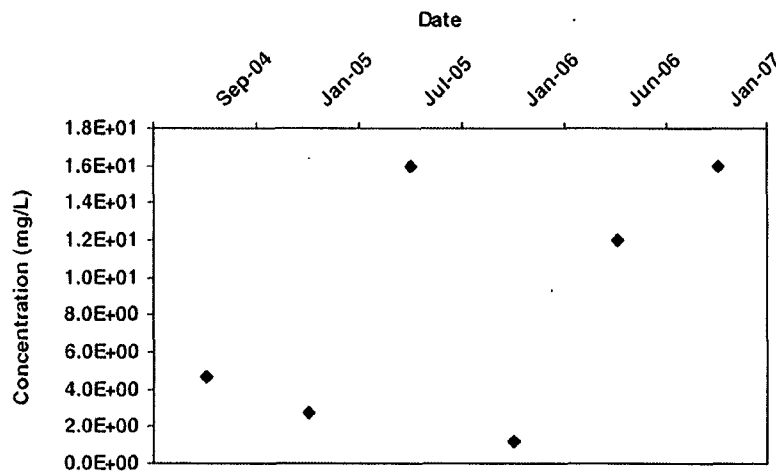

Consolidation Data Table:

Well	Well Type	Consolidation Date	Constituent	Result (mg/L)	Flag	Number of Samples	Number of Detects
OW-6	S	9/1/2004	BENZENE	4.7E+00		1	1
OW-6	S	1/1/2005	BENZENE	2.7E+00		1	1
OW-6	S	7/1/2005	BENZENE	1.6E+01		1	1
OW-6	S	1/1/2006	BENZENE	1.2E+00		1	1
OW-6	S	6/1/2006	BENZENE	1.2E+01		1	1
OW-6	S	1/1/2007	BENZENE	1.6E+01		1	1

MAROS Consolidated Data Summary

Well: OW-6
 Well Type: S
 COC: PYRIDINE

Time Period: 4/1/1989 to 1/1/2007
 Consolidation Period: No Time Consolidation
 Consolidation Type: Median
 Duplicate Consolidation: Average
 ND Values: 1/2 Detection Limit
 J Flag Values : Actual Value

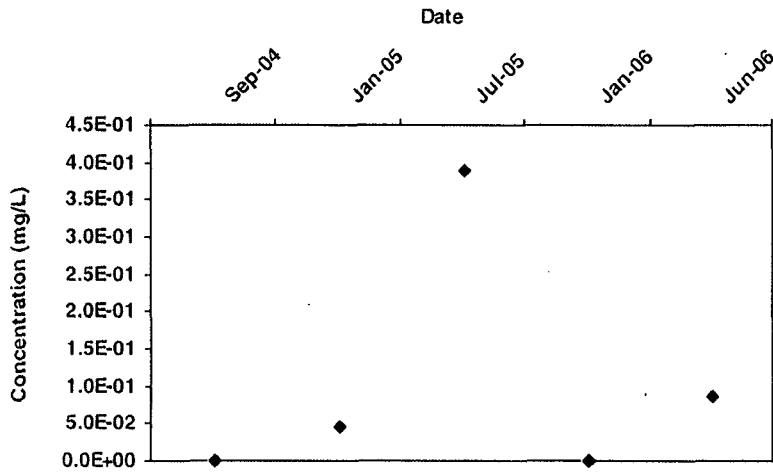

Consolidation Data Table:

Well	Well Type	Consolidation Date	Constituent	Result (mg/L)	Flag	Number of Samples	Number of Detects
OW-6	S	9/1/2004	PYRIDINE	5.0E-04	ND	1	0
OW-6	S	1/1/2005	PYRIDINE	4.6E-02		1	1
OW-6	S	7/1/2005	PYRIDINE	3.9E-01		1	1
OW-6	S	1/1/2006	PYRIDINE	5.0E-04	ND	1	0
OW-6	S	6/1/2006	PYRIDINE	8.6E-02		1	1

MAROS Consolidated Data Summary

Well: OW-6
 Well Type: S
 COC: 2-PICOLINE (ALPHA-PICOLINE)

Time Period: 4/1/1989 to 1/1/2007
 Consolidation Period: No Time Consolidation
 Consolidation Type: Median
 Duplicate Consolidation: Average
 ND Values: 1/2 Detection Limit
 J Flag Values : Actual Value

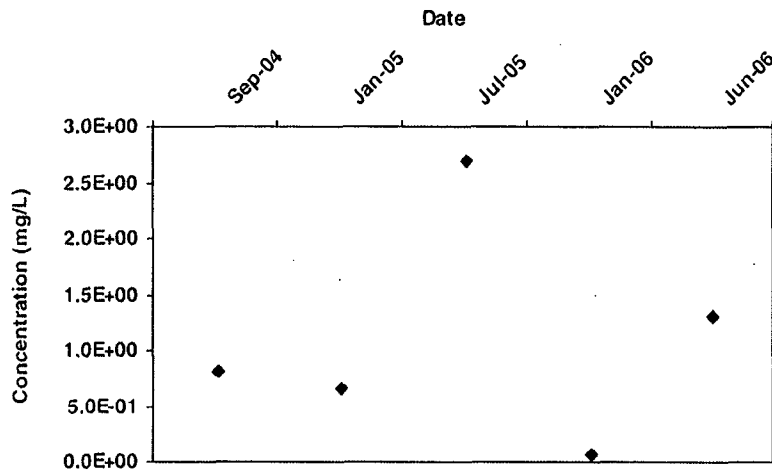

Consolidation Data Table:

Well	Well Type	Consolidation Date	Constituent	Result (mg/L)	Flag	Number of Samples	Number of Detects
OW-6	S	9/1/2004	2-PICOLINE (ALPHA-PICOLINE)	8.2E-01		1	1
OW-6	S	1/1/2005	2-PICOLINE (ALPHA-PICOLINE)	6.6E-01		1	1
OW-6	S	7/1/2005	2-PICOLINE (ALPHA-PICOLINE)	2.7E+00		1	1
OW-6	S	1/1/2006	2-PICOLINE (ALPHA-PICOLINE)	7.6E-02		1	1
OW-6	S	6/1/2006	2-PICOLINE (ALPHA-PICOLINE)	1.3E+00		1	1

MAROS Consolidated Data Summary

Well: OW-7
 Well Type: S
 COC: BENZENE

Time Period: 4/1/1989 to 1/1/2007
 Consolidation Period: No Time Consolidation
 Consolidation Type: Median
 Duplicate Consolidation: Average
 ND Values: 1/2 Detection Limit
 J Flag Values : Actual Value

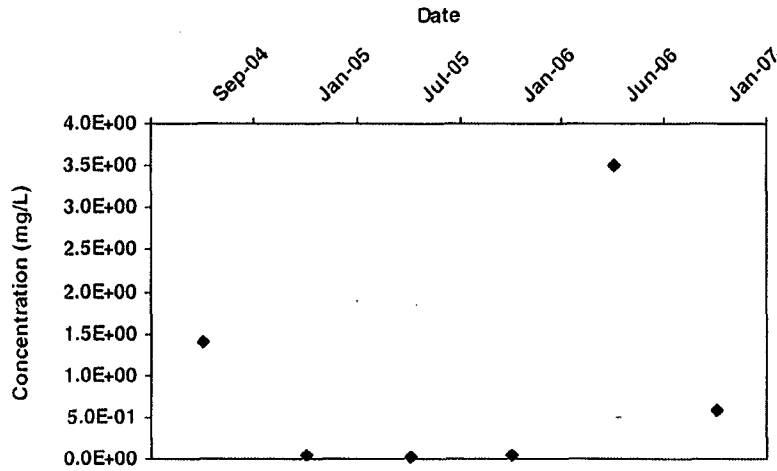

Consolidation Data Table:

Well	Well Type	Consolidation Date	Constituent	Result (mg/L)	Flag	Number of Samples	Number of Detects
OW-7	S	9/1/2004	BENZENE	1.4E+00		1	1
OW-7	S	1/1/2005	BENZENE	4.1E-02		1	1
OW-7	S	7/1/2005	BENZENE	3.3E-02		1	1
OW-7	S	1/1/2006	BENZENE	5.4E-02		1	1
OW-7	S	6/1/2006	BENZENE	3.5E+00		1	1
OW-7	S	1/1/2007	BENZENE	5.9E-01		1	1

MAROS Consolidated Data Summary

Well: OW-7
 Well Type: S
 COC: PYRIDINE

Time Period: 4/1/1989 to 1/1/2007
 Consolidation Period: No Time Consolidation
 Consolidation Type: Median
 Duplicate Consolidation: Average
 ND Values: 1/2 Detection Limit
 J Flag Values : Actual Value

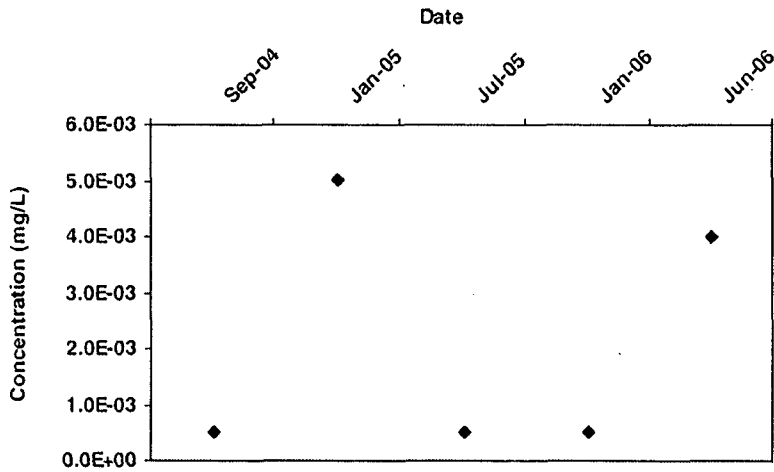

Consolidation Data Table:

Well	Well Type	Consolidation Date	Constituent	Result (mg/L)	Flag	Number of Samples	Number of Detects
OW-7	S	9/1/2004	PYRIDINE	5.0E-04	ND	1	0
OW-7	S	1/1/2005	PYRIDINE	5.0E-03		1	1
OW-7	S	7/1/2005	PYRIDINE	5.0E-04	ND	1	0
OW-7	S	1/1/2006	PYRIDINE	5.0E-04	ND	1	0
OW-7	S	6/1/2006	PYRIDINE	4.0E-03		1	1

MAROS Consolidated Data Summary

Well: OW-7
 Well Type: S
 COC: 2-PICOLINE (ALPHA-PICOLINE)

Time Period: 4/1/1989 to 1/1/2007
 Consolidation Period: No Time Consolidation
 Consolidation Type: Median
 Duplicate Consolidation: Average
 ND Values: 1/2 Detection Limit
 J Flag Values : Actual Value

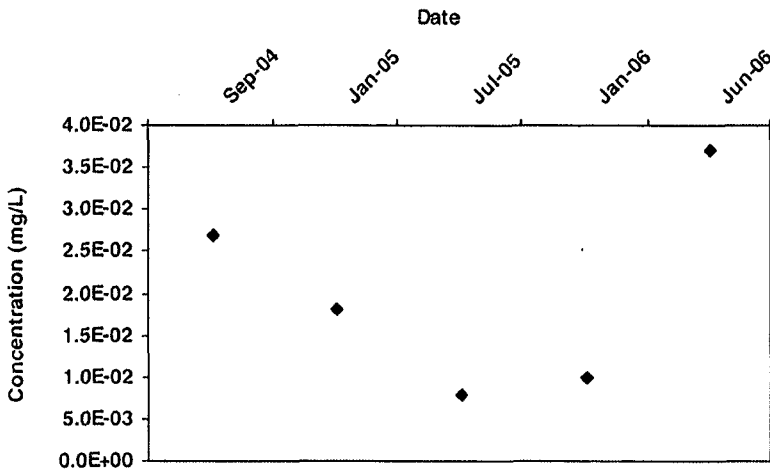

Consolidation Data Table:

Well	Well Type	Consolidation Date	Constituent	Result (mg/L)	Flag	Number of Samples	Number of Detects
OW-7	S	9/1/2004	2-PICOLINE (ALPHA-PICOLINE)	2.7E-02		1	1
OW-7	S	1/1/2005	2-PICOLINE (ALPHA-PICOLINE)	1.8E-02		1	1
OW-7	S	7/1/2005	2-PICOLINE (ALPHA-PICOLINE)	8.0E-03		1	1
OW-7	S	1/1/2006	2-PICOLINE (ALPHA-PICOLINE)	1.0E-02		1	1
OW-7	S	6/1/2006	2-PICOLINE (ALPHA-PICOLINE)	3.7E-02		1	1



APPENDIX D



Appendix D

Well Logs

MAYBROOK HARRIMAN TRUST

HARRIMAN SITE

**COMPILED BORING AND WELL
CONSTRUCTION LOGS**

3/29/2007

MAYBROOK HARRIMAN TRUST

HARRIMAN SITE

COMPILED BORING AND WELL CONSTRUCTION LOGS

Tab 1

TB1(MW-1)-(MW19)

Tab 2

MW20 - MW24

Tab 3

MW25S/D-MW27S/D

Tab 4

PZ-1 - PZ-4

Tab 5

MW 53S/53D

Tab 6

MW28 - MW34

Tab 7

OW6 and OW7
MW35-MW37
RW-1R
VER/SVE

Tab 8

Biosparge Well Logs

Tab 9

Parking Lot and Lagoon Pre-design Boring Logs



MAYBROOK TRUST
WELL CONSTRUCTION LOGS

MW-1 - MW-11

MW-1 - MW-11

DRILLING INFORMATION

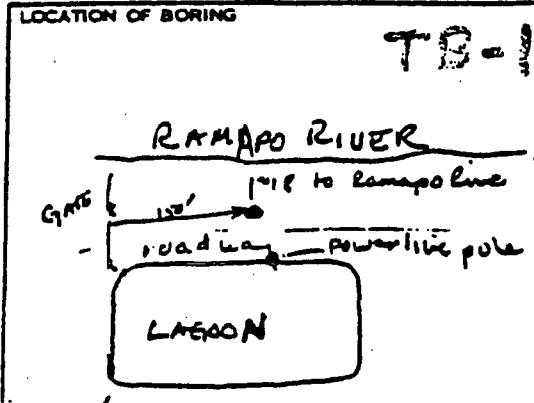

JOB NO. NPW-585	CLIENT Nepawa	LOCATION Harrison, N.J.
DRILLING METHOD: Gardner Denver mud rotary		BORING NO. 100 101
SAMPLING METHOD: 2 3/8" SS w/ 300 lb (also using 3" + 2 1/2" at surface) Hammer.		SHEET 1
Casing Depth: 36"-42" deep.		DRILLING
WATER LEVEL		START TIME 1400
TIME		DATE 5/21
DATE		
CASING DEPTH		

DATUM		ELEVATION							
SAMPLER TYPE	INCHES DRIVER RECOVERED	DEPTH OF CASING	SAMPLE NO. SAMPLE DEPTH	BLOWS/FT. SAMPLER	NUMBER OF RINGS	DEPTH IN FEET	SOIL GRAPH		
3" SS	24 16"	-	2'	3		0	IS		
				7		1			
2 1/2" SS	24	-	2 4'	10		2			
				6		3			
2 3/8" SS	24 16		3 6'	14		4			
				5		5			
				4		6			
				7		7			
2" SS	24"		4 8'	4		8			
				3		9			
				8		10			
2" SS	24 8"		5 10'	8		11			
				30		12			
				11		13			
				14		14			
						15			
	24"		6 15'	8		16			
	0			7		17			
				6		18			
				5		19			

SURFACE CONDITIONS: **DRY GRASS COVERED SANDY LOAM TOPSOIL.**

0-1' silt/clay w/ sandy top
Gray/brown mottled ~~clay~~ ~~clay~~ vegetation little rounded gravels.

1-2' grades to sandy silt little clay large gravels up to 1" rounded. leaching or iron staining evident

2-4' med. gray silt/fine sand wet. (br. 4).
5' little clay. (slightly varved)

10-11' med. gray plastic clay w/ large dk grey fragments w/ var. in SS. sized - degrees of rounding, some brown + red-brown ss gravels

15' lg cobble in bit (no sample)

DATE 5/21 BY CHN

LOCATION OF BORING

JOB NO.

NPW-585

CLIENT

Nepura

LOCATION

Harriman

DRILLING METHOD:

BORING NO.

101-1

SHEET

2 of

SAMPLING METHOD:

DRILLING

WATER LEVEL

START

TIME

TIME

DATE

DATE

CASING DEPTH

SEE PAGE 1

DATUM

ELEVATION

SAMPLER TYPE	INCHES DRIVER INCHES RECOVERED	DEPTH OF CASING	SAMPLE NO. SAMPLE DEPTH	BLOWS/FT. SAMPLER	NUMBER OF RINGS	DEPTH IN FEET	SOIL GRAPH	SURFACE CONDITIONS:
						20		fine gravels
						1		same cobbles as 21
						2		
						3		Fine gravels
						4		24' higher to cobbles.
						5		smaller drilling =
						6		
						7		cuttings show small % of gray clay w/ coarse sand & fine gravels - qtz, shale frags
						8		
						29'		larger % gray clay
						30		
2" SS	21/10		6/30	6		31		gray clay matrix containing coarse sand to pebble sized angular particles - also some fine sand/c particles mostly gray colored, some Fe colored
				5		32		
				48		33		
				50/33"		34		cuttings: coarse sand + fine gray matrix of till. Angular gray parts very abdt w/ some calcite + other light colored frags
						35		
11	9/6		7/35	46		36		Brown-gray clay matrix 50% dark gray angular frags 50% lighter frags - qtz, calcite, others larger pebbles present w/
				70-73"		37		
						38		
						39		

DATE 2/12/62 GHK:q BY

LOCATION OF BORING 73-1		JOB NO.	CLIENT Peperu	LOCATION 12 miles
DRILLING METHOD:				BORING NO. 100
SAMPLING METHOD:				SHEET 3 of
WATER LEVEL				DRILLING
TIME				START TIME
DATE				FIN TH
CASING DEPTH				DATE

See Page 1

DATUM		ELEVATION				SURFACE CONDITIONS:	
SAMPLER TYPE	INCHES DRIVEN INCHES RECOVERED	DEPTH OF CASING	SAMPLER NO. SAMPLE DEPTH	BLOWS/FT. SAMPLER	NUMBER OF RINGS	DEPTH IN FEET	SOIL GRAPH
2" 35	7 6	7	46 20 3in			35	Brownish clay matrix
						1	(36-38) 400 lb pressure drill running
						2	intermittently, rough - cuttings
						3	similar to before
						4	38 - smoothed out - soft material
						5	
						6	
						7	
						8	
						9	
2" 55	12 6	8	12 40 105			40	Gray clayey silt - silty clay matrix
						1	with larger + more abundant cobbles
						2	of same composition as before.
						3	Graywacke-ish cobbles
						4	43.5' } cobbles 500 lbs /
						5	44.5' }
						6	
						7	

DATE: _____ CHK'D BY: _____

LOCATION OF BORING

JOB NO.

CLIENT

LOCATION

Nepan

Herriman

DRILLING METHOD:

BORING NO.

~~1~~ - 1

SAMPLING METHOD:

SHEET

4 of 7

DRILL

WATER LEVEL

START

FINISH

TIME

TIME

TIME

DATE

DATE

DATE

CASING DEPTH

See Page 1

DATUM

ELEVATION

SAMPLER TYPE	INCHES DRIVEN INCHES RECOVERED	DEPTH OF CASING	SAMPLE NO. SAMPLE DEPTH	BLOWS/FT. SAMPLER	NUMBER OF RINGS	DEPTH IN FEET	SOIL GRAPH	SURFACE CONDITIONS:
2" SS	12 5		9 SD	25 69		50		gray - brown silty clay matrix - very hard. coarse sand - fine gravel angular pebbles, mostly gray colored
						1		
						2		
						3		
						4		
						5		
						6		
						57		57: ^{cutting} fine - med gravels. predom. sh of cut 30% It has colored to stz + calcite
						8		
						9		58: It has clay / silt / sand color. black oily film in ^{drilling} fluid from 56-60
2" SS	4 4		10 60	100 → 4"		60		Yellow-brown clayey silt with some angular fine gravel (less than before ~ 20%)
						1		
						2		
						3		Terminated at 60' 4"
						4		
						5		
						6		
						7		

LOCATION OF BORING
 731
 See PS 1

JOB NO.	CLIENT	LOCATION
	Nepera	Harrima
DRILLING METHOD:		BORING NO.
		731-1
SAMPLING METHOD:		SHEET
		5 of
WATER LEVEL		DRILLING
TIME		START TIME
DATE		FIN TIME
CASING DEPTH		DATE
		DA

DATUM		ELEVATION		BLOWS/FT. SAMPLER	NUMBER OF RINGS	DEPTH IN FEET	SOIL GRAPH
SAMPLER TYPE	INCHES DRIVER RECORDED	DEPTH OF CASING	SAMPLE NO. SAMPLE DEPTH				
						60	
						1	
						2	
						3	
						4	
2" SS	5/3	11	65	100 → 5"		65	
						6	
						7	
						8	
						9	
2 1/2" SS	9/8	12	70.5	38 → 3		70	
						1	
						2	
						3	
						4	
SS		13				5	
						6	
						7	

SURFACE CONDITIONS:

cuttings: >50% light colored (creamy yellow) material + gray frag. Dolomite 61-63 1/2 large c

cuttings: dolomite, part + graywack chips apparently no clay

Sample: yellow brown clayey silt matrix containing abundant organic sand & gravel sized grains matrix graywackish in appearance & color

cuttings: graywack dolomite part soft drilling 66-68, rougher below 68. looser material - not much drill from 69.5-70.5 large cobbles

Sample: yellow brown clayey silt with lots of gravel + sand mostly dolomite + graywack

cuttings: >50% dolomite with graywack → no clay picked up white clay silt 74 ft flakes

Sample - all wash upon hit cobble 75-76" horizon 76-77.5 - loose horizon

DATE _____ CHECKED BY _____

TB-1

MTS
7-2-85

Nepera Harriman 5/24/85
~~test~~ ~~well~~ behind lagoon
Test-Boring

78 - 80.5	very hard	Yellow dolomite & dark gray fine gr
80.5 - 83	fractured	Less Dolomite w/
83 - 84	hard	
84 - 87	fractured	Color changing to black, more fissile to
87 - 89	hard	virtually no yellow
89 - 89.5	fractured	
89.5 - 92	hard	

Hole later abandoned (5/29) + grouted
Returned to 91', grouted from 88' up to
the 6" casing, top not sealed yet

Nepera Plant wide

6/3/85

copy

9:00 - arrived - Ken + Tom already here. They were trying to force a 4 1/2" bit at the end of deep hole, we decided to just put deep hole work and moved to location next to rock well R-3 will call this

shallow well:

located 10' east of R-3.

MW-2

15
10/15

30
in
blowing

Depth	Drops per feet	Counts	SANDS #/type	Description	Comments
5-7	24/7	5-5-5-5	1 SS	med brown silt, cl. w/ some sands + gravels alt. layer grey <u>SILT</u>	fill up
10-12	24/15	1-1-2-2	2 SS	med/lt brown silt with 2" vf-f brown sil and 1" " " " same	at 2' " 6' " 5'
			Silt - 1 silt - s + s S + S →	grading to <u>sandy silt</u> with higher % S + S. lower 2" fine gravels.	S + S at = 11'
15-17	24/8	2-2-4-3	none	gravels up to 1" no fines in SS.	
20-22	24/9	2-1-1-12	3 SS	well-graded lt + med brown f-m sands	5.00 ing
22-23		drilling	very	difficult - cuttings indicate boulders fragments - calcite/Li.	
25'			4 grab	cuttings: various <u>gravels</u> predom 1/2" + larger erratics fairly angular Sh + Ls some cal + orange ss(?) cuttings indicate br? at 26 - 28	fluid at 24.5' 24.5' - 28' lost 1/2 to water
END					

- 1:45-12:15 construct well: bentonite pellets 28 ~~28~~ 22.5'
- 1:5-1:00 water fillup. 10' screen (.02 -) 22.5'-1
15' pipe 12.5 - +
- 5 - Construct well gravel packed 22.5-12'
bentonite 12-10'
- 20 - clean up well, wash rig. at MW-2
cuttings to steam clean but here not allowing su
pressure.
- 3:30 moved to MW-3 + set-up.
begin drilling

MW-3

Depth	Driven rod	B-C	sample #/type	Description	Comments
-2 2 1/2					Topsoil sandy silt some gravel
13.5 5-7	24"/20"	3-3-5-4	1/SS	Cuttings " "	Lt. brown to med. br. clay 0-4" br. silty clay w/ gravel 4-20 - brown silt with 1" gray clay layer at 8" 1/2" " " at 15" variable black particles traces orange staining
9.5 12	24"/12"	2-1-5-4	2/SS	2a upper 6" 2b lower 6"	rounded coarse gravels. 0-6" brown silt w/ vt-f sand layers trace clay 6-8" grades to si/sa/gr 8"-12" S+g well rounded sh + ls. calcite, dol?
-17	24"/16"	16-12-12-10	3/SS		0-10" si/sa/gr up to 2" 10-16" S+g coarse gravels - glacial errat " " slight water sa/gravels trace to no cla trace to some silt.
7.5 2.5 5-22	24"/10"	14-7-3-9	4/SS		

24-27 20/10 7/10 5/SS
 Driven
 Description
 P.S. June
 similar to 20-22

28' drilled - backfilled to 25'

2 surges

15-25

.020"

25-13

sand 1 1/2 barrel

13-10.5

portland

bucket

1 bag grout.

- 1/2 fill truck w/ H₂O
- buy 125 purchase

10 set-up... 120 → ~200-250' (east) from "point" in Face line
 w/ 120 stand-by
 begin drilling

Depth	Sample #/type	Blow Counts	Description	Comments
2-3	grab		gray-brown silty clay w/ ^{small} gravel	grading to less clay
5-7 24/16	1/SS	4-4-5-8	brown silt w/ trace sand trending to silt alt.	gray silty clay/clay at 10" & changes to gray clay at 13" w/ gray silty clay, slight brown silt layers.
10-12	24/16	1-3-3-3	gray clay w/ ^{occasional} fine to silty layering	
5-17	24/16	1-2-1-1	gray clay w/ varying	last 2" course ^{of} gray sand
20-22	24/12	2-1-1-1	0-3" gray sands	
			3-7" brown silt.	
5-27	24/16	1-1-1-2	7-12" alt. gray silty clay + gray clay w/ occ	vf-f-sand
			0-9 Fine to coarse sand	
			9-12-16 (grading to fine sand & silt)	Brown silt
			12-16	
			12-16 Small approx 1" clay layer	(mud)
			16-18 - Fine sand	

MW 4

June 4, 19

Description

Depth	Soil	Flow	Flow	Description
0-4	6/SS	1-1-1-1		Fine sand site
4-8 1/2	7/SS	1-1-3		Coarse sand with some gravel all gray brown
8-12	8/SS	3-2-3-5		all layer well-graded dk-brown / gray vf - m sand " " " / gray vf-med sand
12-17	9/SS	1-1-13-8		3" orange med-grained sa at 4
17-52				0-19 med-light brown Fine-med sand Fractured gravel Water loss in sands

slight dk oily substance in med p. seems similar to shen observed at MW-1.

harder with bedrock

at 55' - smaller freshly broken fragments - pred. 2 1/2' of dk gray to med. gray fragments limestone

through 30.5

clean out hole set casing

52.5 - 42.5' 0.20" screen sand 3/4 barrel. bentonite grouted 2 bar + 1 cem.

ft 6:00

June 5 wed.

rainout at 9:00 AM

June 10

p. 2

with
42-45

Sample #/type B.C. ^{inches} Dr/Rec.

Comments
add 2nd bag of gel; drilled to 45
lost 300-400' gel.

sands (easy drilling)

9:45

cleaned out hole to 37' left for water set down
10:45

1:30

added $\frac{1}{2}$ bag reverb + will attempt to
ream hole from 37 to 45

~ 1:00 - 1:45

Spoke w/ Med at 4W-5.
explained the activities to date.
he mentioned DEC fellow (Barney?) was here Fri
May 31 to inspect Blind Lagoon - DEC man
said that mud's pathway to River was a v.
thin subject to 500' fine although he would not
do so at this time.

1:00

set screen at 35-45' and sand pack
32.5' bentonite to 30' + the
grout.

refill ~~water~~ water truck + move to ^{set up} Blind Lagoon
Blind Lagoon

Depth	So. No. & type grab	Blow counts	inches Dr/rec	Description
2				yellow brown silt w/ ^{some to trace} v-f sands & gravel
7	1-SS	2-3-66	24/21	brown silt with several layers of brown silty to clay up to 1" thick occasional v-f sand layers $\leq 1/4"$ changes to grey silts & sands 7 sands moist throughout
12	2-SS	2-3-23	24/20	grey / grey brown clay slightly silty substance - lighter than all previous finds.
17	3-SS	1-2-1-2	24/20	(predom silts)
22	4-SS	2-1-1-2	24/18	(few gravels in cuttings at 19.5) higher % v-f sands; layers up to 2" 1 clay layer 2" at 20.5'
27	5-SS	3-5-3-5	24/14	grey silt 0-6" fine med gravels 6-10" si/sa/gravel 10-14" admixture
32	6-SS	12-10-8-8	24/14	0-3 si/sa/gravel 3-7 fine grey sand 3-14 sa gravel trace si
33.5				course gravels & cobbles
37	7-SS	21-30-50	18/10	cuttings fine sa - 1/2" gravels slightly to med. more blade oil film at (35-35) tough grey silt matrix with sa & gravels some to trace clays
5:30	Quit	for	day -	

June 7
Hesper

drillers
ready to drill

Depth	Sample # / Type	B.C.	Wells Dr./Rec	Comments
39-39.5				Cuttings: similar to 35' sample % of clay slightly higher.
39				Cobbles
40.5	8 / grats	-	-	f-c sands + gravels up to 1/2 little to trace fines; but fragments of dk ls
45-47	9/SS	37-32-24-2	24/20	(more oily materials entering zones of coarse materials sands matrix w/ gravels trace to little fines "very loose materials" entry, with cuttings similar to the nearby stream gravel + c sands but 1/2" gravels is higher % with depth
47-55				"very loose materials" entry, with cuttings similar to the nearby stream gravel + c sands but 1/2" gravels is higher % with depth
65	10 / grats	-	-	S+G "still loose"
69.5-71.5	11/SS	19-10-18-15	24/8"	^{entry} oily matrix matrix w/ clay sands Gravels. Similar to 3 similar to 70' more black oily material very hard drilling - lg. particles similar to 70' w/ higher %
75				
76				
77				
80-82	12/SS	24-25-50	18/15	cobbles/sa/gr with silt to silt w/ traces of clay and small gravels. Very tough (more oils at 81. cuttings similar to 82's higher % clay less gravel soft drilling - more brown brown ss + silt + gravel trace to no clay
85				
85-88.5				
88.5-90				
90-92	13/SS	60/50-1"	7/3	

drillers
ready to drill

85-

June
M

Depth	Depth	Sample #/type	B.C.	Notes Dr/Rev.
0	95.5			
	96			
	97-98			

less belays
 very hard drilling - perhaps
 on top of bedrock - black/
 ls/cal frags fresh by cut
 well as typical structures
 previously encountered
 bedrock - ls/dol
 mod gray to dk gray

2:00 stopped drilling at 1:30
 preparing to leave
 quit for day.

MW-6 p. 484

CODY
Nepera (Tues)

10:00 AM. - preparing to drill with air rotary set-up at
MW-6
Monday 4" casing driven and pressure grouted to 10'
4:5 mechanical problems with state truck - delaying start
of drilling.

drilled to 135' on Tuesday.

wednesday drilled to 173'

Thursday MW-7 shallow well next to MW-6
began drilling at 9:45 after set-up, water, mud

MW-7

at 15-ft black oily substance encountered; heavier conc. has
than in MW-6. looks like a silty-silvent-like material.

~ 15 - gray clay cuttings

22-24 - gray clays with inc % of fine black/dk gray

25 - - gravels. -

26 - very coarse gravels/cobbles.

32-34 large boulder.

35 - small cobbles gravel.

36.5 - gray clay in cuttings.

38 - STOPPED / CONVERT to 35' water fell back into opening.

screen: 25'-35'

well development + grouting + installation of prot. casing, etc. remain
of day - 3:00. 5:30 PM.

Friday June 14

9:30 set up at MW-8, developing MW-2
mud-pump broken no drilling

Monday June 17

radiater broken - no drilling.

Tuesday June 18

Fuel Pump Gasket needs replacing, drilling delayed 1.5 hours.

WEPREP 6/18/

Tuesday June 18

55-5453

- Nepesha Plastics - COOY
- contact surveyor - next week?
- 1/3 gamma log -
- Sampling activities -

MWB

945 804 repairs completed begin drilling -

Depth	Sample #/type	B.C	inches dr/rec	Description.
5	1 SS	1-1-3-3	24"/0	- black fine-grained material w/ some gravel chemical fill
7.5	1	cuttings		" "
10	2 SS	2-2-4-7	24"/14"	- change easier drilling - d/k gray - clay/si/se/gravels (up to 1 appears to still be fill material with strong oil-chemical odor
12				- more coarse materials at 12'
15	3 SS	2-3-4-4	24"/16"	- M.T. LAYERS MED. GRAY VF-F SAND w/SH w/ OCC. GRAY CLAY LAYER.
20	4 SS	2-2-3-2	24"/24"	- predom. MED. GRAY SILT w/ 1" CLAY LAYER TRACE TO NO SANDS.
25	5 SS	4-3-1-1	24"/20"	- F-SAND LAYER AT 26.5' INTERVAL OTHERWISE SIMILAR TO 20' INTERVAL
28	6 SS	4-5-5-6	24"/16"	- predom F-SAND OCC SILT LAYER OCC MED SAND. TRACE/NO
31	7 SS	1-1-0-2	24"/18"	- predom SILT w/ SOME CLAY LAYERS, OCC. F-M SAND.
34	8 SS	1-0-4-4	24"/24"	- FINE SANDS LOWER 12" occasional CLAY LAYER w/ si/sit up 12"
37	9 SS	cuttings 5-7-7-7	24"/16"	trace vf-f coarse sands with gray clay s gray sandst? si
40		CUTTINGS		" "

NEPERA
6/18/85

MW-8

10 AM.

at 67' gravels encountered. The VF SANDS ARE DAMP
AT 50' NOT MOIST + function same to 67'
drilled to 70' will set 5' screen at 65-70'

LUNCH 12-1:30 P.M. " " "

MW-9

Rt 17 + RR overpass

Depth Sample #/Type B.C. $\frac{11.}{dr/Kic}$

DESCRIPTION

				grass
				gray-yellow clay
				dk gray/black clay + sm fill? sewage or oily chem c
1	SS	2-2-3-3	24"/16	dk gray to black silt (vf sand discolored) med color appears to be med graye
15				change (9.5' : drilling slightly ^{more} roughly)
17	Z	SS	25-11-26-12	24"/6" med gray / black mixture of silt w/ gravelly some clays.
15-11				black substance in water.
14				drilling softened sand?
X	SS	8-3-2-1	24"/0	no recovery
-18				very large water loss - 250 gallons? added 2 nd bag supergel + 1/4 bag revert
-3	SS	15-13-16-23	24"/12"	It broken sand with coarse gravel of 1/4 size meta carbonate material. little silt.
				gravel lens ends ends at 18 ft.
				gravel layer encountered still losing H ₂ O
				Very coarse gravel over 1" subangular
4	SS	23-50/4"	10"/0"	no recovery.
				SAMPLE NO 4 WASH - contains gravel from 22-25'
				steady very loud drilling cuttings show dk gray to light carbonate fragments - bedrock?
				400 lbs / pressure - some calcite frags -
				slightly fractured rock - larger fragments same material

MW-9-

14-21

screen

hole collapse from 26-21.

21-13

sand 2.5 barrels.

13 10

pellets.

MW-10

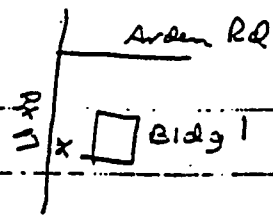

0-20 black, silty organic rich fill
(see shallow well for details)

20-20 Dolomitic Bedrock
- upper part light gray fine grained
- middle part dark gray fine grained
- lower part dark gray sands to

cased to 28 feet

ING DWS	PROJECT _____ LOCATION _____	BEGIN BORING: DATE _____ TIME _____
	BORING NO. <u>MW-6 (4" Rodwell)</u>	FINISH BORING: DATE _____ TIME _____
	GROUND ELEV. _____ B.M. ELEV. _____	

DRIVE HAMMER	{ DISTANCE DROP _____ INCHES WEIGHT _____ POUNDS CASING SIZE _____	WATER OBSV. PIPE _____ FT.	GROUND WATER DATE _____ HOUR _____ AM _____ PM _____ DEPT _____
		CORE BIT SIZE _____	
SPOON HAMMER	{ DISTANCE DROP _____ INCHES WEIGHT _____ POUNDS SPOON SIZE _____ INCHES	UNDISTURBED SAMPLE SIZE _____ INCHES O.D.	
		ANGLE OF INCLINATION _____	
		WATER PRES. TEST _____	

DEPTH FROM-TO	DESCRIPTION	SAMPLE NUMBER	EARTH		REMARKS
			DEPTH FROM-TO	SPOON BLOWS PER 6 INCHES	
0-97'	Overburden				
97-99 1/2'	Hard Gray Rock ^{Limestone - Diabite} - 300-400 PSI				
99 1/2-100'	Fractured Rock - 100 PSI				
100'-101'	Hard Rock - 300-500 PSI				
101'-101 1/2'	Fractured Rock - 100 PSI				
101 1/2'-103'	Hard Rock - 300-700 PSI				
107'	Fracture				
109'	Fracture				
122'					
122'	Fracture				
124'	Fracture				
128 1/2'	Fracture (Color Change Light Gray Rock)				
132'	Fracture				
140'	Fracture				
145'	Fracture (Color Change Darker Gray Rock)				
149'	Fracture				
150-155'	Fractures				
163'	Fracture → First Sign of Water				
164'	Fracture				
166-167'	Softer Rock				
168'	Fractures				
172'-173'	Fractures				

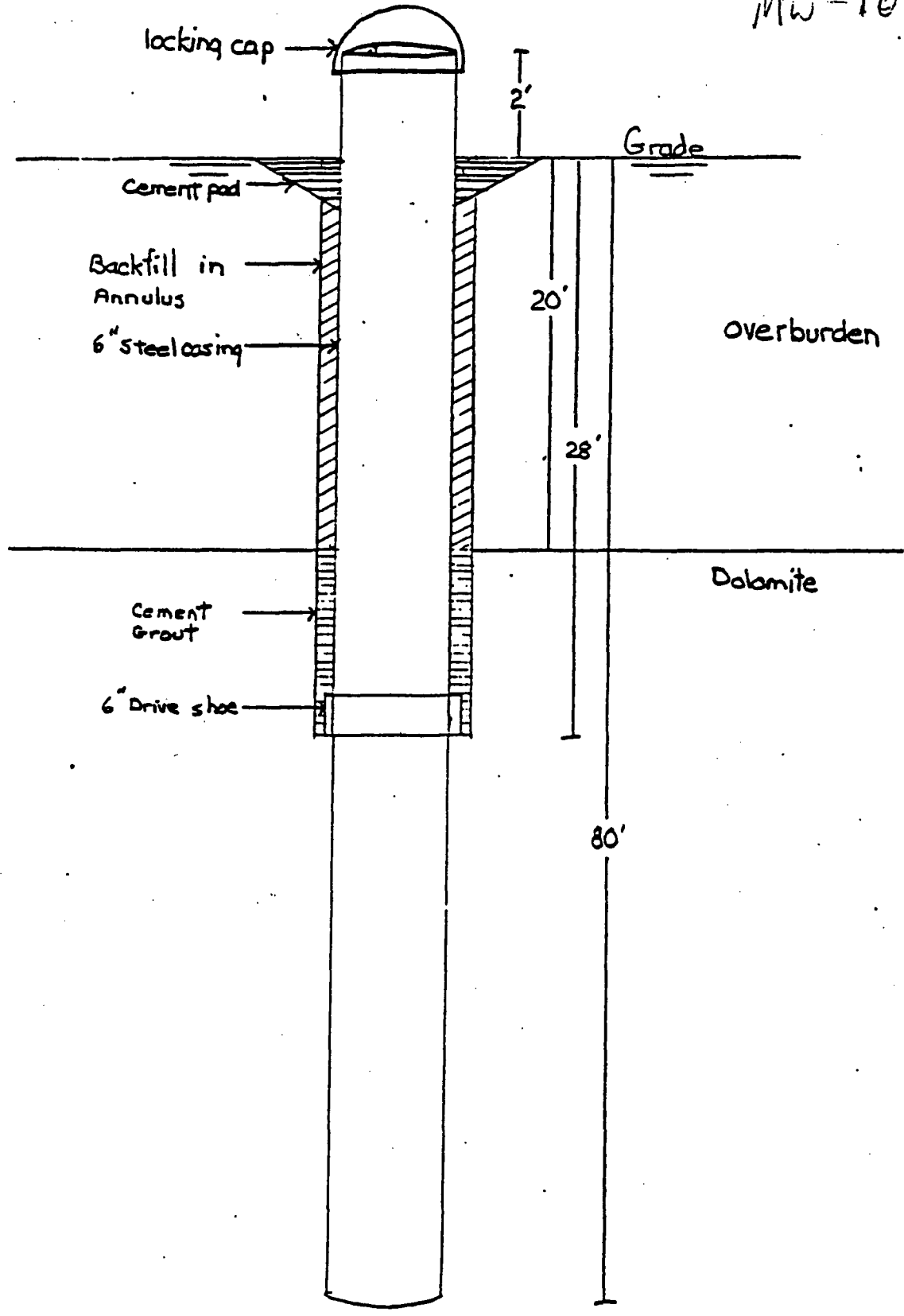

Nepera well 1
'As Built'
not to scale

Boyd Artesian Well, Co., Inc.
 R.D. No. 5 Rte. 52
 Carmel, N.Y. 10512
 (914) 225-3196

MW-10



WELL LOG

PROJECT Harriman II
 CLIENT NEPERA
 ENGINEER C. A. Rich
 LOCATION Harriman

WELL NO. 1
 SHEET NO. 1 OF 1
 DATE STARTED 6-25-85
 DATE FINISHED 6-25-85
 DRILLER Chuck
 EQUIPMENT DIII

EQUIPMENT INSTALLED	DEPTH IN FT.	FORMATION & SAMPLES	REMARKS
6" steel casing	0-20	- Grey-black, saturated, silty sand, organic odor overburden	
driveshoe			
cement	20-28	- Casing into ledge	
drilling cap			
	28-40	- Grey-black Dolomite, medium drilling, milky colored water	
	40-50	- very dark grey-black Dolomite and Dolostone, milky colored water	
	51	- 6" seam	
	54	- 6" seam	
	55	- End of Rod 2, ± 16 PM	
	50-60	- Dark grey-black Dolomite and Dolostone, medium drilling, ± 16 PM, Graphite slick	
	61	- 6" seam	
	65	- milky colored	
	60-70	- Dark grey-black Dolostone, medium drilling, ± 16 PM, graphite slick	
	70-80	- Same, no graphite	
		- Final TEST : 16 PM	

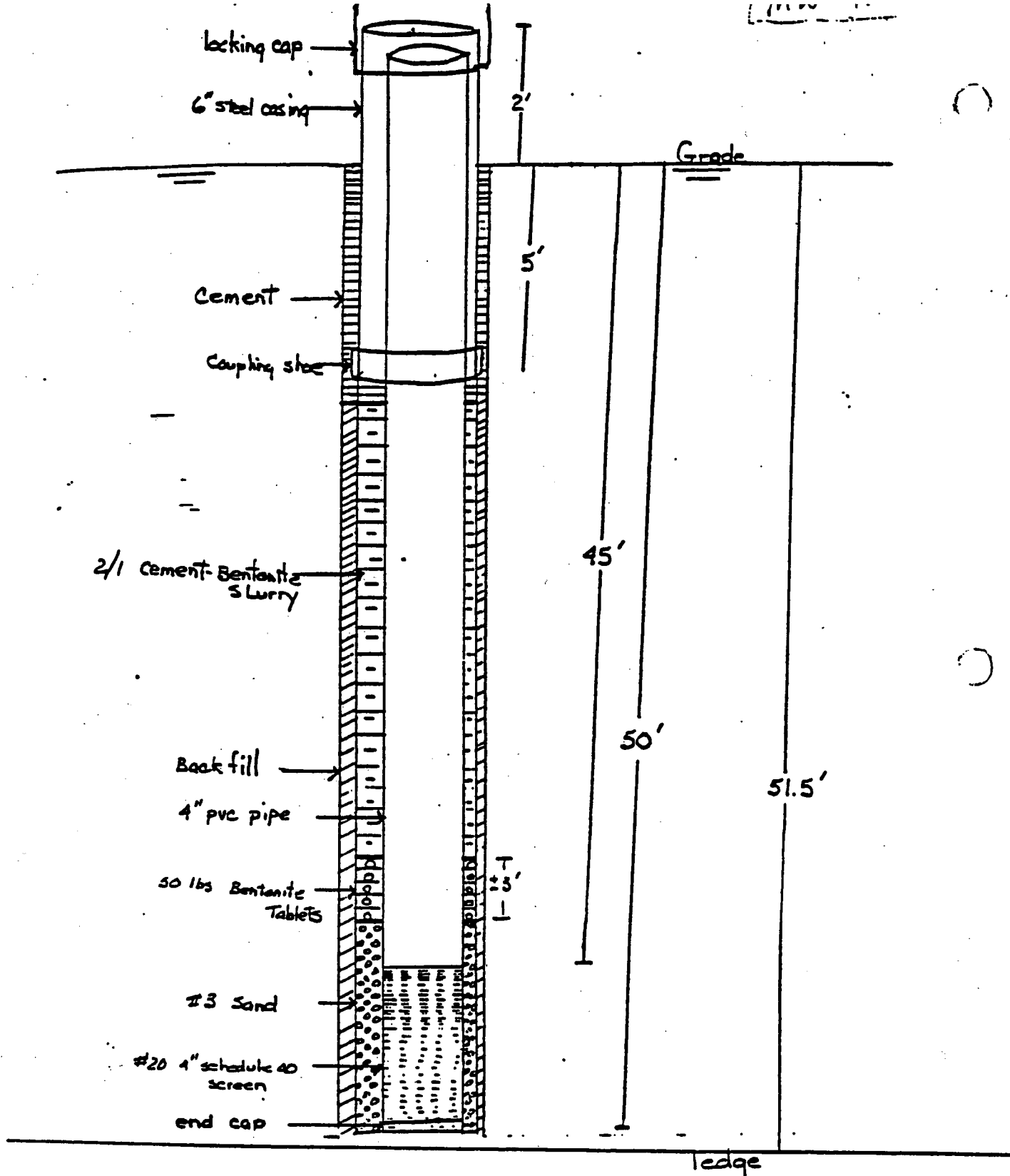

Nepera Well 2
 'As Built'
 not to scale

MW-14

Ft.
below
grade

Stratigraphic
column

Geologic Description

0

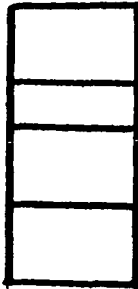

Brown and gray silt and fine sand.
Pebbly near surface.

5

Brown and gray coarse sand, grains subangular
to subrounded.

10

Brown, gray and brownish gray silt and
fine sand.

15

Gray silt and silty clay, finely laminated.

End of Boring
14 Ft.

MW-19

0

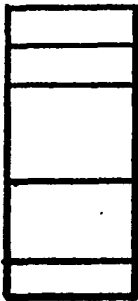

Dark brown coarse sand and fine gravel, slight black
staining evident. Grains subangular to subrounded.

5

Light brown silt and fine sand.

10

Brown coarse sand and fine gravel overlying grayish
black stained material. Grain subangular to
subrounded.

15

Gray and black stained silt and fine sand.

Gray and gray-green finely laminated clayey
silt.

End of Boring
15 Ft.

Ft.
below
grade

Gamma Log

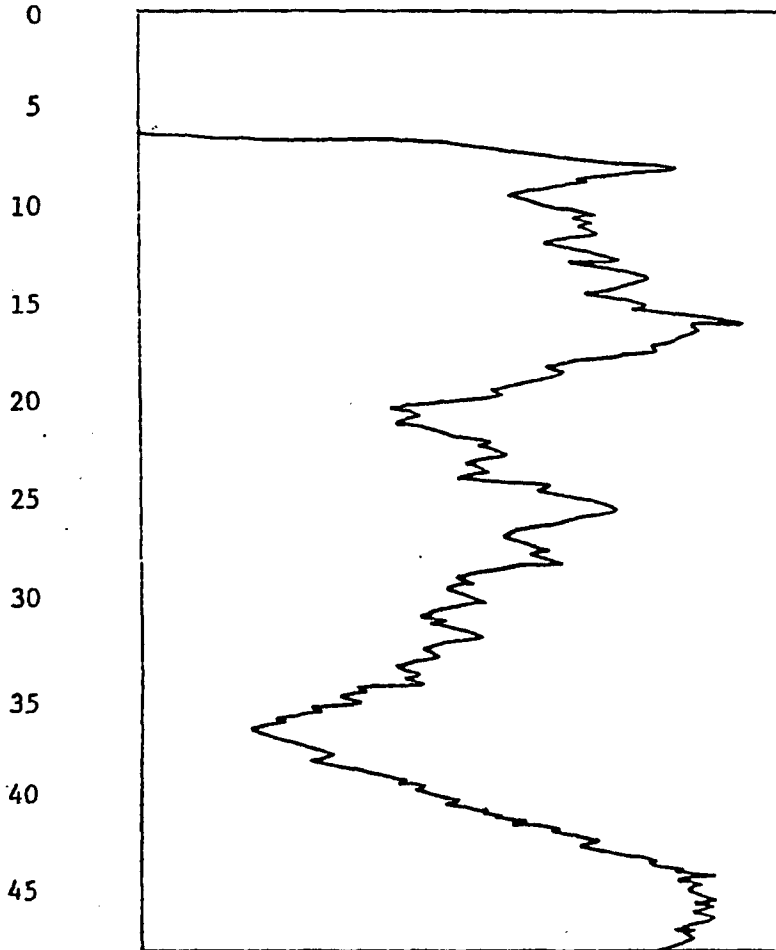

Stratigraphic
column



Geologic Description

Brown coarse sand and fine gravel fill containing abundant buried debris.

Uniform varved gray silt and clayey silt grading down to underlying unit.

Gray-brown fine sand, hard and slightly pebbly.

Gray medium to coarse sand with abundant angular shale chips. Bears large amount of water.

Gray varved clayey silt lens.

Gray medium to coarse sand as above.

bedwell?

FT.
below
grade

Gamma Log

5
10
15
20
25
30
35
40
45
50
55
60
65
70
75

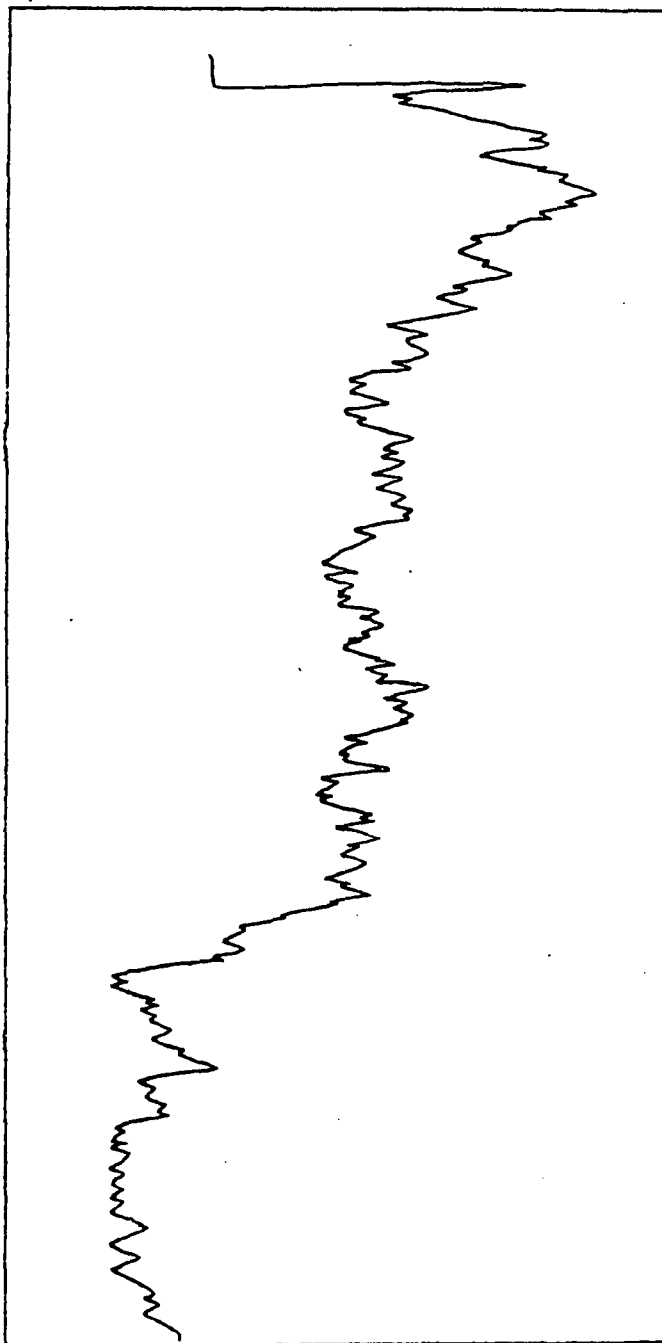

Stratigraphic
column



Geologic Description

Brown coarse sand and fine gravel,
at least partially fill.

Gray clayey silt with fine varved
laminations, grading down to gray
brown fine sand, slightly pebbly
and well compacted.

Gray brown medium sand containing
abundant angular shale chips. Water
bearing.

Light brown laminated silty clay lens.

Gray brown medium sand as above.

Gray dolomite bedrock.

Fracture



MW-21S/21D

MW-22

MW-23S/23D

RW-1

MW-24

R-3D

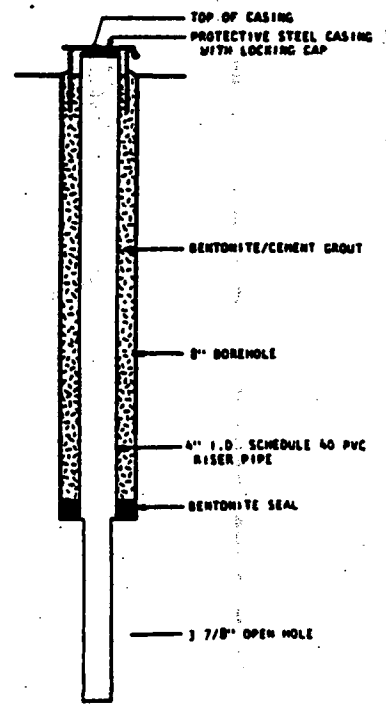
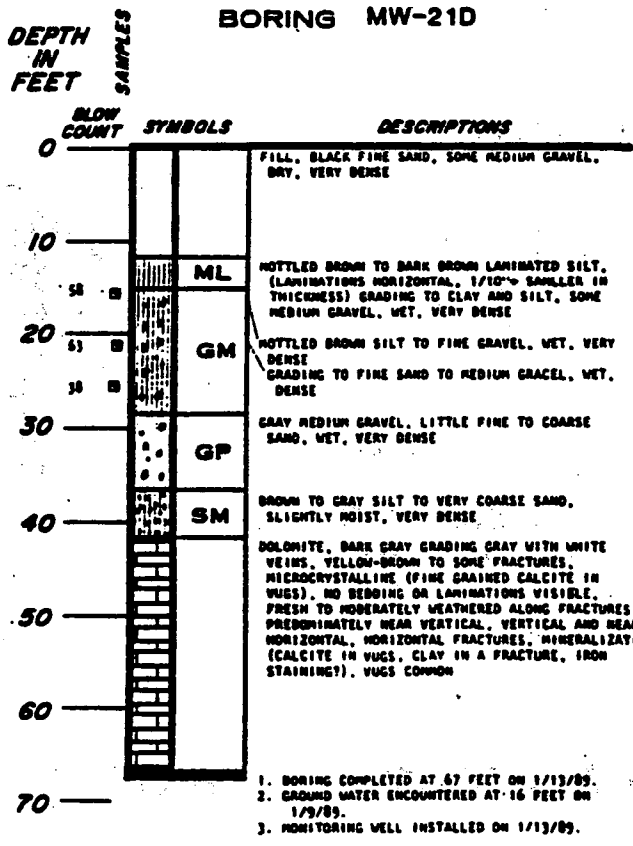
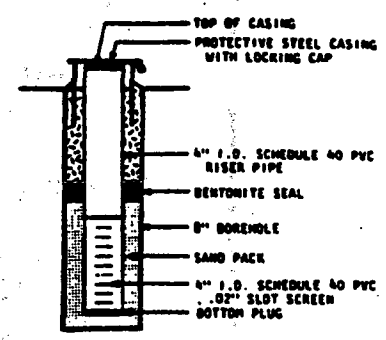
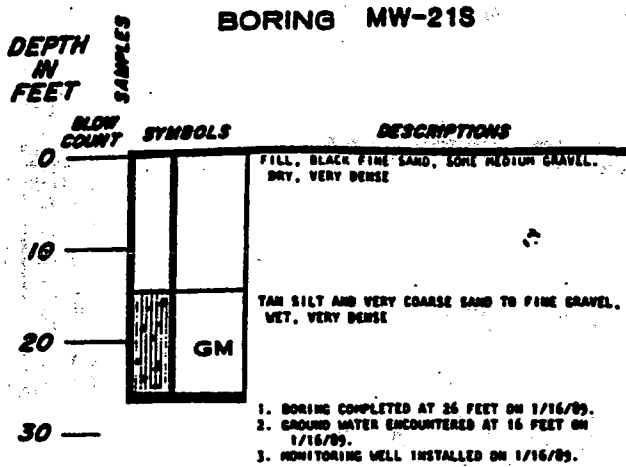

LOG OF BORINGS AND MONITORING WELL DETAILS

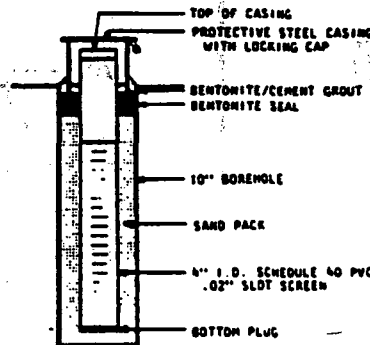
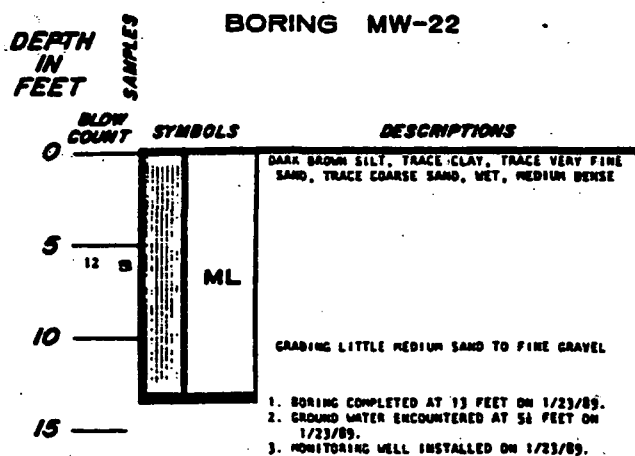
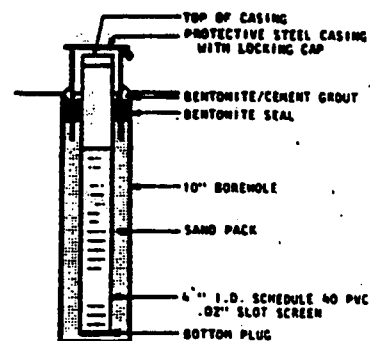
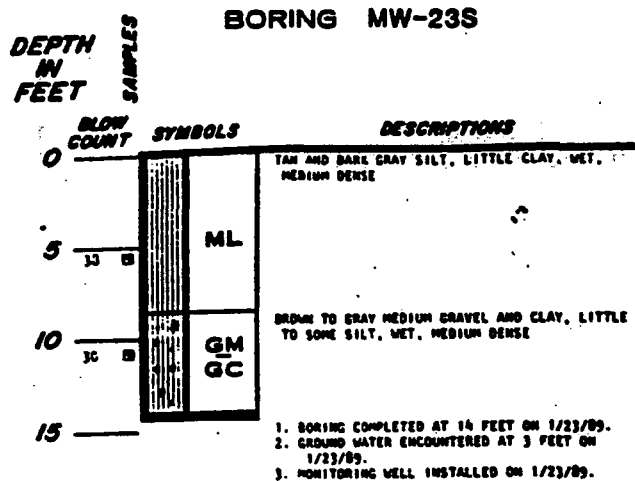

LOG OF BORINGS AND MONITORING WELL DETAILS

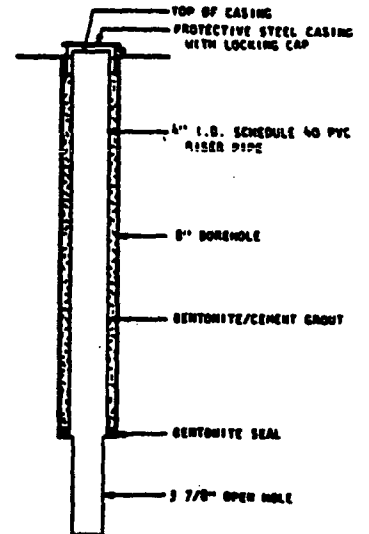
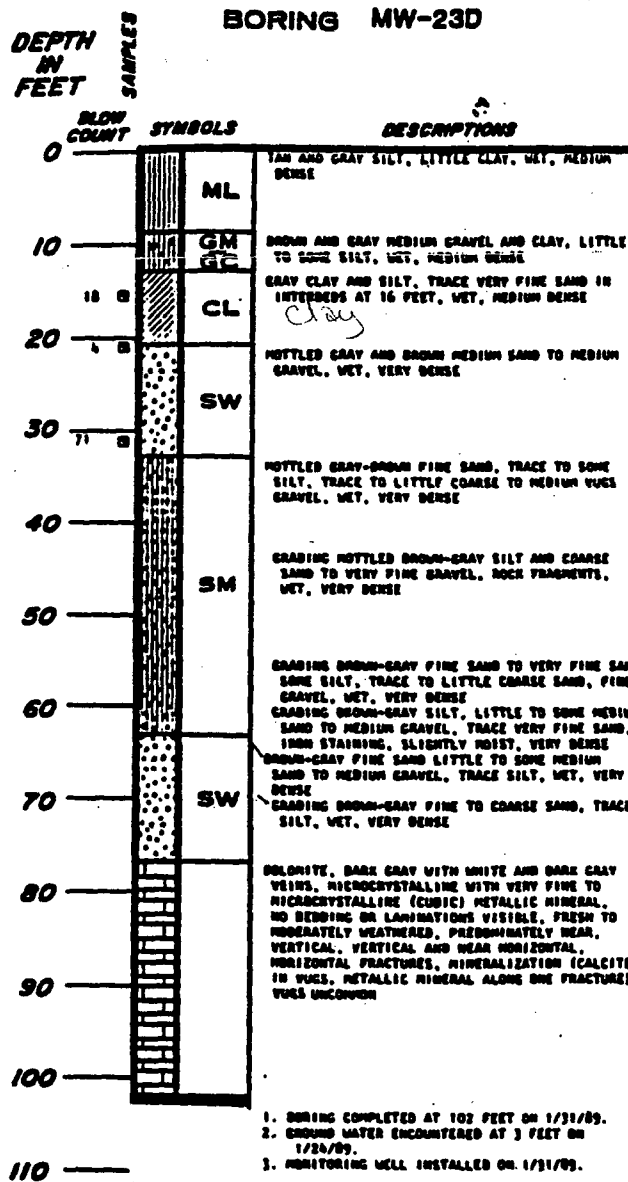

1. BORING COMPLETED AT 102 FEET ON 1/31/89.
2. GROUND WATER ENCOUNTERED AT 3 FEET ON 1/24/89.
3. MONITORING WELL INSTALLED ON 1/31/89.

LOG OF BORING AND MONITORING WELL DETAILS

DEPTH
IN
FEET

BORING RW-1

DEPTH IN FEET	BLOW COUNT	SYMBOLS	DESCRIPTIONS
0			MOTTLED TAN, BROWN AND GRAY SILT, TRACE CLAY, WET, MEDIUM DENSE
23	18	ML	GRABING SOME CLAY, WET, MEDIUM DENSE
10	18		
18	7		
20	6		
30	20	SW	GRABING SILT AND CLAY, FINE BLACK SUB-HORIZONTAL TO HORIZONTAL LAMINATIONS, WET, VERY LOOSE GRABING SILT AND VERY FINE SAND, LITTLE CLAY, WET, MEDIUM DENSE
40	25		
50	32		
50	42		MOTTLED BROWN FINE TO VERY COARSE SAND, TRACE SILT, WET, VERY DENSE
60			

1. BORING COMPLETED AT 56 FEET ON 1/18/89.
2. GROUND WATER ENCOUNTERED AT 13 FEET ON 1/17/89.
3. MONITORING WELL INSTALLED ON 1/19/89.

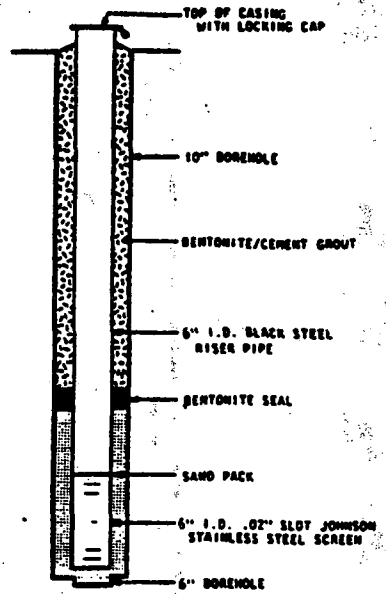

DEPTH
IN
FEET

BORING MW-24

DEPTH IN FEET	BLOW COUNT	SYMBOLS	DESCRIPTIONS
0		SW	BROWN FINE SAND TO MEDIUM GRAVEL, MOIST, MEDIUM DENSE
5	13	CL-ML	BROWN-GRAY SILT AND CLAY, SLIGHTLY MOIST, MEDIUM DENSE
10	26	GW	GRAY-BLACK COARSE SAND TO MEDIUM GRAVEL, WET, MEDIUM DENSE
15	9		
20	20	SM	GRAY VERY FINE SAND, SOME SILT, WET, MEDIUM DENSE
20	16		

1. BORING COMPLETED AT 20 FEET ON 12/20/88.
2. GROUND WATER ENCOUNTERED AT 10 1/2 FEET ON 12/20/88.
3. MONITORING WELL INSTALLED ON 12/20/88.

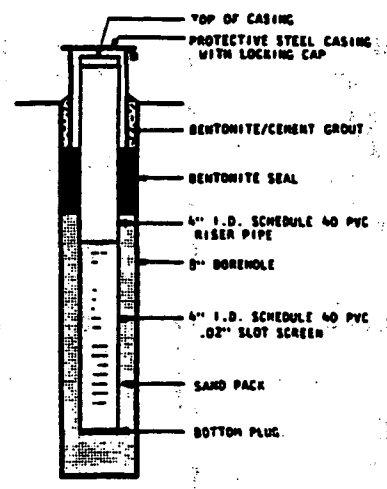

LOG OF BORINGS AND MONITORING WELL DETAILS

- NOTES
1. THE FIGURES IN THE COLUMN LABELED "BLOW COUNT" REFER TO THE NUMBER OF BLOWS REQUIRED TO DRIVE A STANDARD SPLIT-SPOON SAMPLER A DISTANCE OF ONE FOOT USING A 140 POUND DRIVE WEIGHT FALLING 30 INCHES. THE STANDARD SPLIT-SPOON SAMPLER IS 2" D.D. AND 1-3/8" I.D.
 2. THE DISCUSSION IN THE TEXT OF THE REPORT IS NECESSARY FOR A PROPER UNDERSTANDING OF THE NATURE OF THE SUBSURFACE MATERIALS.

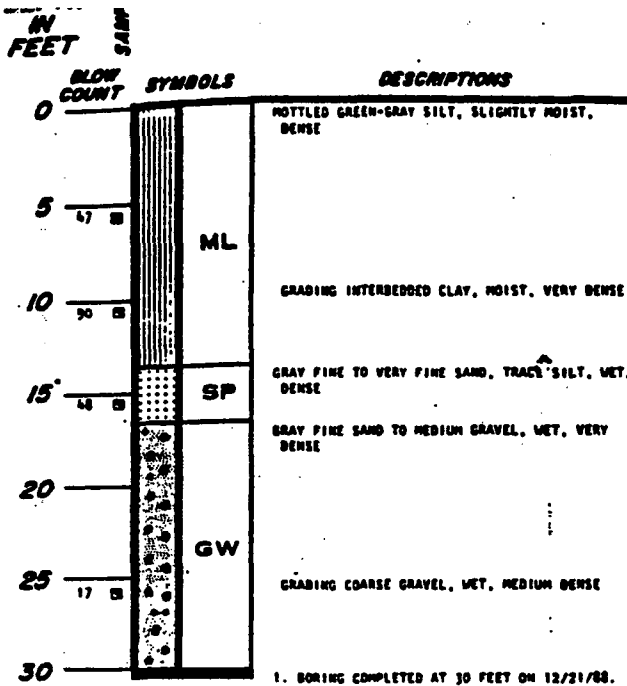

1. BORING COMPLETED AT 30 FEET ON 12/21/88.
2. GROUND WATER ENCOUNTERED AT 7.5 FEET ON 12/21/88.
3. MONITORING WELL INSTALLED ON 12/21/88.

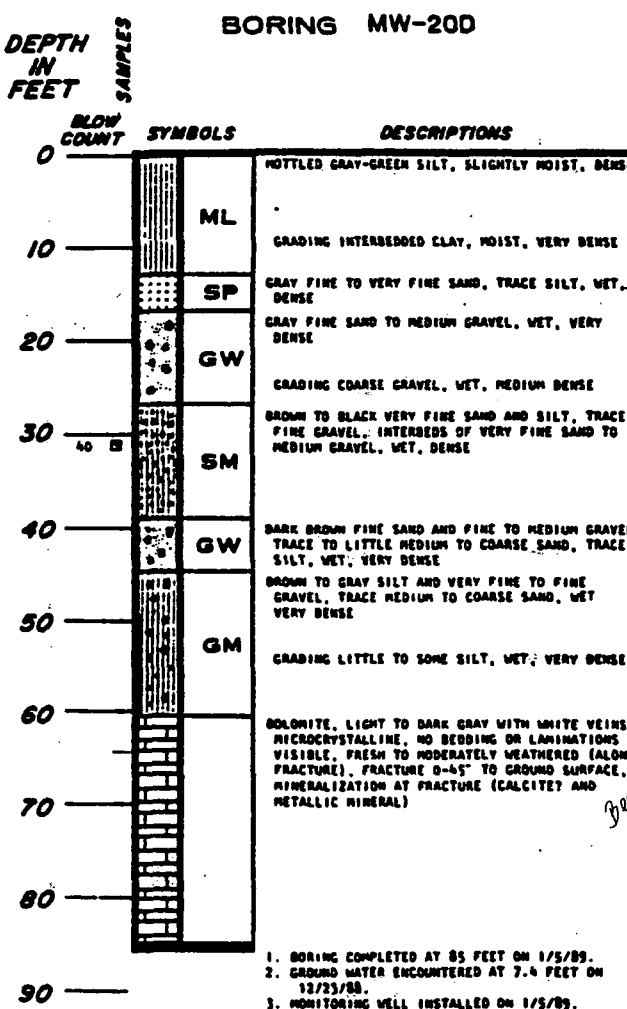
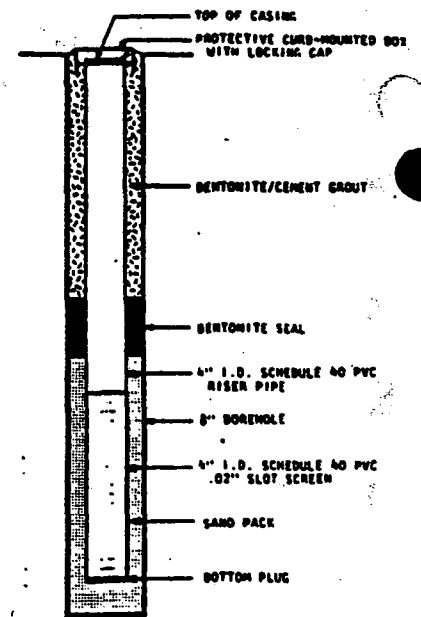

1. BORING COMPLETED AT 85 FEET ON 1/5/89.
2. GROUND WATER ENCOUNTERED AT 7.4 FEET ON 12/23/88.
3. MONITORING WELL INSTALLED ON 1/5/89.

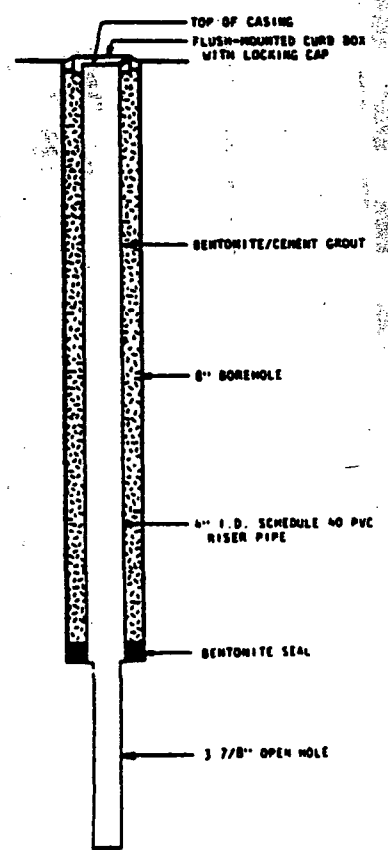

LOG OF BORINGS AND MONITORING WELL DETAILS

Dames & Moore

WELL R-3

P.O.C. - COM - ETC
PLEASE

LAYNE-NEW YORK CO., INC.
1324 WEST ELIZABETH AVE. LINNEN, N. J.
DRILLERS REPORT

JOB NO. 437902 DRILLER T. Molitor CUSTOMER WELL NO. 3
 CUSTOMER APRA-CHEM LAYNE WELL NO. _____
 WELL LOCATION _____ STATE PERMIT NO. _____

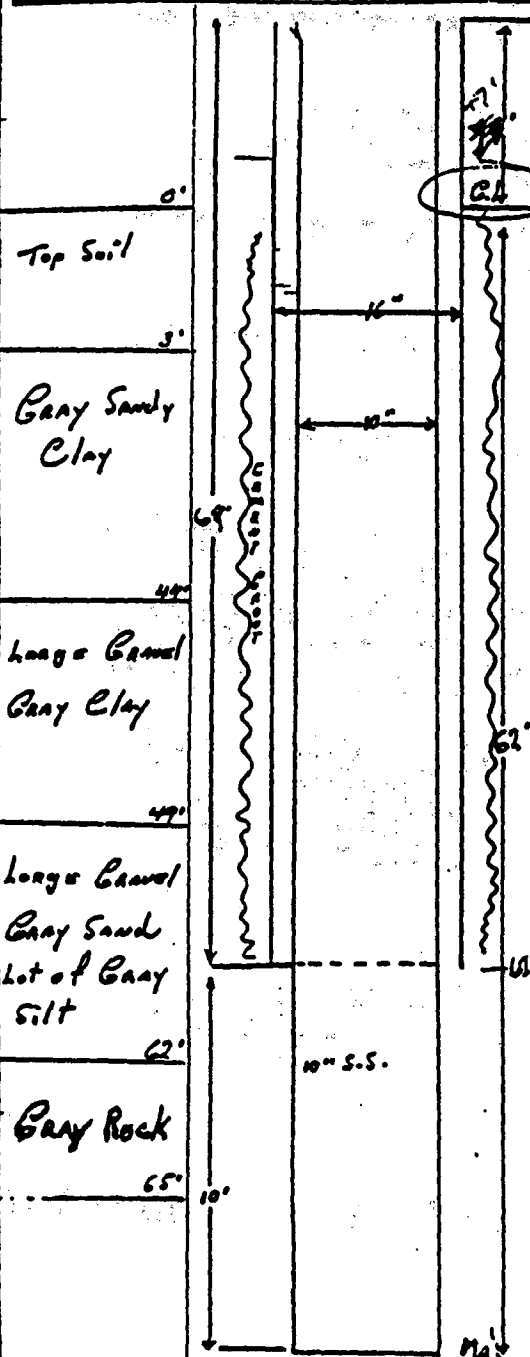

PIPE SET:

DIA.	WALL	LGTH.	MATL.	T & C TO WELDED
16"		58'		UNWELDED
18"		58'		" "
24"		66'		" "

PIPE LEFT IN PLACE:

DIA.	WALL	LGTH.	MATL.	T & C TO WELDED
16"	7.375	58'		UNWELDED
18"	7.375	58'		" "

SCREEN:
 NOM. SIZE 10" I.D. LGTH. 10' ORIG. 100
 MFG. JOHAN TYPE W.N. METAL S.S. GA. NO. _____
 DET. IN SAND & GRAVEL FORMATION _____
 DIA. _____

MISCELLANEOUS:
 R & L BACK OFF _____ CUT OFF _____ PACK TYPE _____

CONG:
 DIA. TOP _____ DIA. BOT. _____ LGTH. _____ MATL. _____

PLUG:
 DIA. _____ LGTH. _____ MATL. _____

GRAVEL:
 AMT. 6 BAGS + 2 = 8 BAGS PWR. REQ. _____ CLAY _____
 SIZE _____ BAGS LAYNEITE B-3 _____

CEMENT:
 BAGS USED _____ CLAY _____ SEAL _____
 YDL. CONCRETE _____ LGTH. _____

METHOD OF DRILLING:
 STD. ROT. REV. ROT. CABLE TOOL AIR ROT.
 OTHER _____

MEASUREMENTS:
 GROUND ELEV. _____ ABOVE SEA LEVEL _____

DEPTH OF WELL AFTER PLUG _____ FROM GRD. LEV.
 DEPTH TO GRAVEL WALL _____ FROM TOP OF _____
 ORIG. GRD. L.

MISCELLANEOUS:
 DATE WORK STARTED 11/17/77 DATE FIRST PUMPED ?
 DID WELL CLEAR UP _____ HOW SOON _____
 WAS SAND PUMPED _____ HOW LONG _____
 HOW LONG AGITATED _____ HOW LONG PUMPED _____
 CHEM. USED TO DEVELOP _____ SAMPLE TAKEN _____

PRELIMINARY TEST DATA:
 STATIC LEVEL ? DATE ? WATER TEMP. ?
 CAPACITY ? GPM WITH ? PUMPING LEVEL ?

SKETCH OF LOCATION

T. Molitor
SIGNATURE OF DRILLER

BORING MW-23D

DEPTH IN FEET	SAMPLES	BLOW COUNT	SYMBOLS	DESCRIPTIONS
0			ML	TAN AND GRAY SILT, LITTLE CLAY, WET, MEDIUM DENSE
10			GM GC	BROWN AND GRAY MEDIUM GRAVEL AND CLAY, LITTLE TO SOME SILT, WET, MEDIUM DENSE
18	18		CL	GRAY CLAY AND SILT, TRACE VERY FINE SAND IN INTERBEDS AT 16 FEET, WET, MEDIUM DENSE
20		4	SW	MOTTLED GRAY AND BROWN MEDIUM SAND TO MEDIUM GRAVEL, WET, VERY DENSE
30		71	SW	MOTTLED GRAY-BROWN FINE SAND, TRACE TO SOME SILT, TRACE TO LITTLE COARSE TO MEDIUM VUGS GRAVEL, WET, VERY DENSE
40			SM	GRABING MOTTLED BROWN-GRAY SILT AND COARSE SAND TO VERY FINE GRAVEL, ROCK FRAGMENTS, WET, VERY DENSE
50			SW	GRABING BROWN-GRAY FINE SAND TO VERY FINE SAND, SOME SILT, TRACE TO LITTLE COARSE SAND, FINE GRAVEL, WET, VERY DENSE
60			SW	GRABING BROWN-GRAY SILT, LITTLE TO SOME MEDIUM SAND TO MEDIUM GRAVEL, TRACE VERY FINE SAND, IRON STAINING, SLIGHTLY MOIST, VERY DENSE
70			SW	BROWN-GRAY FINE SAND LITTLE TO SOME MEDIUM SAND TO MEDIUM GRAVEL, TRACE SILT, WET, VERY DENSE
80				GRABING BROWN-GRAY FINE TO COARSE SAND, TRACE SILT, WET, VERY DENSE
80				DOLomite, DARK GRAY WITH WHITE AND DARK GRAY VEINS, MICROCRYSTALLINE WITH VERY FINE TO MICROCRYSTALLINE (CUBIC) METALLIC MINERAL, NO BEDDING OR LAMINATIONS VISIBLE, FRESH TO MODERATELY WEATHERED, PREDOMINATELY NEAR, VERTICAL, VERTICAL AND NEAR HORIZONTAL, HORIZONTAL FRACTURES, MINERALIZATION (CALCITES IN VUGS, METALLIC MINERAL ALONG ONE FRACTURE), VUGS UNCOMMON
90				
100				
110				

1. BORING COMPLETED AT 102 FEET ON 1/31/89.
2. GROUND WATER ENCOUNTERED AT 3 FEET ON 1/24/89.
3. MONITORING WELL INSTALLED ON 1/31/89.

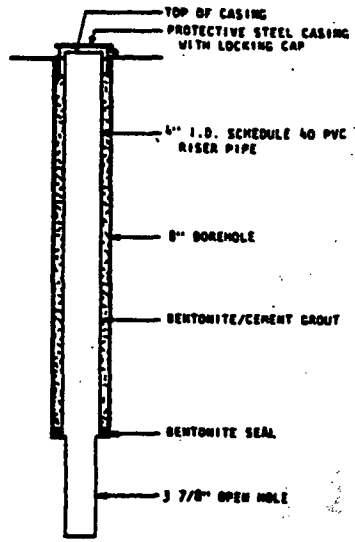

LOG OF BORING AND MONITORING WELL DETAILS



THE
FOLLOWING
DOCUMENTS
WERE OF
POOR
QUALITY

IMAGE
DATA

A Data Distributors Company

MW 255/250

265/260

275/270

STRATIGRAPHIC AND INSTRUMENTATION LOG (OVERBURDEN)

(L-05)

PROJECT NAME: NEPERA - PLANT SITE
 PROJECT NO.: 3697
 CLIENT: NEPERA, INC.
 LOCATION: HARRIMAN, NY

HOLE DESIGNATION: MW-255-91
 (Page 1 of 2)
 DATE COMPLETED: JULY 11, 1991
 DRILLING METHOD: 6 1/4" ID HSA
 CRA SUPERVISOR: R. FIELD

DEPTH ft BGS	STRATIGRAPHIC DESCRIPTION & REMARKS	ELEVATION ft AMSL	MONITOR INSTALLATION	SAMPLE			
				NUMBER	STATE	VALUE	H NU (ppm)
	REFERENCE ELEVATION (Top of Riser) GROUND SURFACE	535.67 533.3					
-2.5	Gravel rock(FILL) CL-CLAY, some silt, trace fine grained sand, trace gravel, soft, brown, wet	532.8		1SS	X	4	14
-5.0							
-7.5	ML-SILT, trace clay, very stiff, brown, moist	526.8					
-10.0	CL-CLAY, little silt, very stiff, gray, moist	524.3 523.0		2SS	X	26	4
-12.5	ML-SILT, trace clay, stiff, gray, wet	521.3 521.3					
-15.0				3SS	X	13	0.9
-17.5	- little clay ML-SILT, trace clay, interbedded with fine sand seams 6" apart, light yellow brown						
-20.0	SP-SAND, very fine grained, medium dense, dark gray to black, saturated	513.6		4SS	X	10	0.2
-22.5	- medium to coarse grained						
-25.0				5SS	X	14	12.5
-27.5	CL-CLAY, trace silt, very stiff, brown, moist	505.8					
-30.0	ML-SILT, interbedded with saturated sand seams, brown, wet	504.5	6SS	X	28	1.4	
-32.5	ML-SILT(TILL), little fine grained sand, occasional clay seam, hard, wet to dilatent	500.8					

NOTES: MEASURING POINT ELEVATIONS MAY CHANGE; REFER TO CURRENT ELEVATION TABLE

GRAIN SIZE ANALYSIS ○ WATER FOUND ∇ STATIC WATER LEVEL ▼

STRATIGRAPHIC AND INSTRUMENTATION LOG (OVERBURDEN)

(L-05)

PROJECT NAME: NEPERA - PLANT SITE

HOLE DESIGNATION: MW-25S-91
(Page 2 of 2)

PROJECT NO.: 3697

DATE COMPLETED: JULY 11, 1991

CLIENT: NEPERA, INC.

DRILLING METHOD: 6 1/4" ID HSA

LOCATION: HARRIMAN, NY

CRA SUPERVISOR: R. FIELD

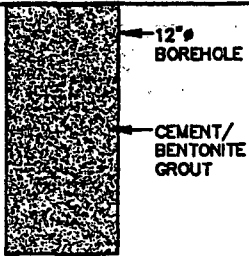
DEPTH ft BGS	STRATIGRAPHIC DESCRIPTION & REMARKS	ELEVATION ft AMSL	MONITOR INSTALLATION	SAMPLE			
				NUMBER	STATE	VALUE	HNU (ppm)
-35.0			 <p>← 12" BOREHOLE ← CEMENT/ BENTONITE GROUT</p>	7SS	X	47	0.2
-37.5				8SS	X	>100	0.2
-40.0	<p>END OF HOLE @ 39.3 FT. BGS</p> <p>NOTES:</p> <ol style="list-style-type: none"> Stratigraphy for MW-25S taken from pilot hole (MW-25Sa) which was augered to 39.3 ft BGS and grouted to ground surface. Installed MW-25S to a depth of 28.0 ft BGS. 	494.0	<p>SCREEN DETAILS: Screened interval: 23.0 to 28.0' BGS Length -5.0' Diameter -4.0" Slot # 10 Material -Plastic Sand pack interval: 18.0 to 30.0' BGS Material -# 4 Quartzite</p>				
-42.5							
-45.0							
-47.5							
-50.0							
-52.5							
-55.0							
-57.5							
-60.0							
-62.5							
-65.0							

NOTES: MEASURING POINT ELEVATIONS MAY CHANGE; REFER TO CURRENT ELEVATION TABLE

GRAIN SIZE ANALYSIS ○

WATER FOUND ∇

STATIC WATER LEVEL ▼

STRATIGRAPHIC AND INSTRUMENTATION LOG (OVERBURDEN)

(L-06)

PROJECT NAME: NEPERA - PLANT SITE

HOLE DESIGNATION: MW-25D-91
(Page 1 of 3)

PROJECT NO.: 3697



DATE COMPLETED: JULY 25, 1991

CLIENT: NEPERA, INC.

DRILLING METHOD: 4 1/4" ID HSA

LOCATION: HARRIMAN, NY

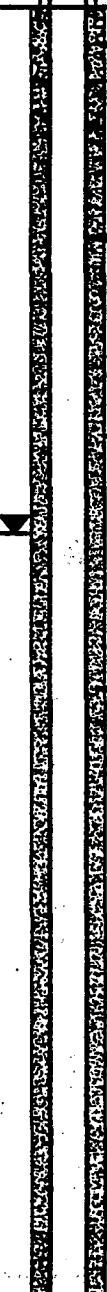
CRA SUPERVISOR: R. FIELD

DEPTH ft BGS	STRATIGRAPHIC DESCRIPTION & REMARKS	ELEVATION ft AMSL	MONITOR INSTALLATION	SAMPLE			
				NUMBER	STATE	VALUE	HNS (ppm)
	REFERENCE ELEVATION (Top of Riser) GROUND SURFACE	535.61 533.3					
	For stratigraphy see MW-25S						
-2.5							
-5.0							
-7.5							
-10.0							
-12.5							
-15.0		519.0					
-17.5							
-20.0							
-22.5							
-25.0							
-27.5							
-30.0							
-32.5							

NOTES: MEASURING POINT ELEVATIONS MAY CHANGE; REFER TO CURRENT ELEVATION TABLE

GRAIN SIZE ANALYSIS 

WATER FOUND 

STATIC WATER LEVEL 

STRATIGRAPHIC AND INSTRUMENTATION LOG (OVERBURDEN)

(L-06)

PROJECT NAME: NEPERA - PLANT SITE

PROJECT NO.: 3697

CLIENT: NEPERA, INC.

LOCATION: HARRIMAN, NY

HOLE DESIGNATION: MW-25D-91

DATE COMPLETED: (Page 2 of 3)
JULY 25, 1991

DRILLING METHOD: 4 1/4" ID HSA

CRA SUPERVISOR: R. FIELD

DEPTH ft BGS	STRATIGRAPHIC DESCRIPTION & REMARKS	ELEVATION ft AMSL	MONITOR INSTALLATION	SAMPLE			
				NUMBER	STATE	VALUE	UNITS (ppm)
35.0							
37.5							
40.0							
42.5							
45.0							
47.5	END OF OVERBURDEN HOLE ● 47.7 FT. BGS	485.6					
50.0							
52.5							
55.0							
57.5							
60.0							
62.5							
65.0							

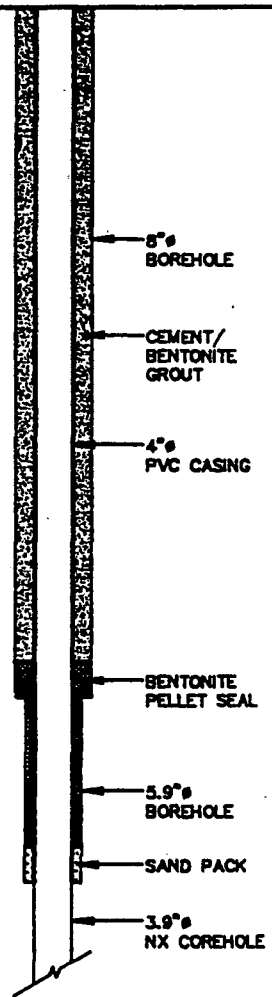

NOTES: MEASURING POINT ELEVATIONS MAY CHANGE; REFER TO CURRENT ELEVATION TABLE
 GRAIN SIZE ANALYSIS ○ WATER FOUND ∇ STATIC WATER LEVEL ▼

STRATIGRAPHIC AND INSTRUMENTATION LOG (BEDROCK)

(L-07)

PROJECT NAME: NEPERA PLANT - SITE
 PROJECT NO.: 3697
 CLIENT: NEPERA, INC.
 LOCATION: HARRIMAN, NY

HOLE DESIGNATION: MW-250-91
 (Page 3 of 3)
 DATE COMPLETED: JULY 25, 1991
 DRILLING METHOD: HSA / NX CORE
 CRA SUPERVISOR: R. FIELD

DEPTH	DESCRIPTION OF STRATA	ELEVATION	MONITOR INSTALLATION	BI EN DT RE OR CY CAL	RN UN NM BELL	CR CO RE VE RY	RO OD	WR AT TE UR N		
ft BGS		ft. AMSL				%	%	%		
47.5	DOLOMITE (Wappingers Formation): dark gray, fine grained, crystalline, highly fractured - iron staining mineralization (● 50.0 ft BGS) - rough weathered fracture (● 51.8 ft BGS) - rough weathered fracture (● 52.3 ft BGS) - rough weathered fracture (● 52.5 ft BGS) - rough weathered fracture (● 53.3 ft BGS) - rough weathered fracture (● 53.6 ft BGS) - calcite deposits and 1mm black healed fracture (● 51.4 and 51.8 ft BGS) - calcite deposits and 1mm black healed fracture (● 55.3 ft BGS) - high angle (60°) fracture (● 56.5 ft BGS) - calcite filled solution cavities (58.3 ft BGS)	485.6								
50.0										
52.5										
55.0										
57.5										
60.0	- high angle, highly fractured zone, slightly weathered (61.4 to 62.4 ft BGS)									
62.5										
65.0	- slightly weathered fracture (● 67.9ft BGS)									
67.5										
70.0	END OF HOLE ● 70.3 FT. BGS	463.0								
72.5										
75.0										

NOTES: MEASURING POINT ELEVATIONS MAY CHANGE; REFER TO CURRENT ELEVATION TABLE

☒ WATER FOUND

☒ STATIC WATER LEVEL

NM - NOT MEASURED

STRATIGRAPHIC AND INSTRUMENTATION LOG (OVERBURDEN)

(L-08)

PROJECT NAME: NEPERA - PLANT SITE
 PROJECT NO.: 3697
 CLIENT: NEPERA, INC.
 LOCATION: HARRIMAN, NY

HOLE DESIGNATION: MW-26S-91
 (Page 1 of 2)
 DATE COMPLETED: JULY 26, 1991
 DRILLING METHOD: 6 1/4" ID HSA
 CRA SUPERVISOR: R. FIELD

DEPTH ft BGS	STRATIGRAPHIC DESCRIPTION & REMARKS	ELEVATION ft AMSL	MONITOR INSTALLATION	SAMPLE			
				NUMBER	STATE	VALUE	HNU (ppm)
	REFERENCE ELEVATION (Top of Riser) GROUND SURFACE	523.40 521.0					
2.5	SM-SAND, fine to medium grained, little silt, trace fine gravel, dense, brown, moist to wet - silt content decreases with depth		CONCRETE SEAL BENTONITE PELLET SEAL				
5.0		515.4 514.7	4" PVC CASING SAND PACK WELL SCREEN	1SS	X	31	0.8
10.0	GP-GRAVEL, fine to medium grained, little coarse grained sand, medium dense, dark gray, saturated	511.5 511.0		(2SS)	X	11	1.5
12.5	ML-SILT, trace clay, very stiff, gray, wet to saturated (dilatent)						
15.0	CL-CLAY, trace silt, soft, gray, moist	508.0		3SS	X	6	0.5
17.5			12" BOREHOLE				
20.0	ML-SILT, trace clay, gray, wet to saturated	501.0		4SS	X	5	0.3
22.5							
25.0	ML/CL-SILT and CLAY, interbedded, soft to firm, gray, silt is wet, clay is moist	497.0	CEMENT/BENTONITE GROUT	5SS	X	4	0.2
27.5							
30.0	SM-SAND, very fine grained, little silt, loose, gray, saturated	492.0		6SS	X	6	0.2
32.5	ML-SILT, trace clay, stiff, gray, wet to saturated	490.2					

NOTES: MEASURING POINT ELEVATIONS MAY CHANGE; REFER TO CURRENT ELEVATION TABLE

GRAIN SIZE ANALYSIS ○ WATER FOUND ∇ STATIC WATER LEVEL ▼

STRATIGRAPHIC AND INSTRUMENTATION LOG (OVERBURDEN)

(L-08)

PROJECT NAME: NEPERA -- PLANT SITE

HOLE DESIGNATION: MW-26S-91

PROJECT NO.: 3697

DATE COMPLETED: (Page 2 of 2)
JULY 26, 1991

CLIENT: NEPERA, INC.

DRILLING METHOD: 6 1/4" ID HSA

LOCATION: HARRIMAN, NY

CRA SUPERVISOR: R. FIELD

DEPTH ft BGS	STRATIGRAPHIC DESCRIPTION & REMARKS	ELEVATION ft AMSL	MONITOR INSTALLATION	SAMPLE				
				NUMBER	STATUS	W VALUE	H N G (ppm)	
35.0	ML-SILT, interbedded with sandy clay, some medium subangular gravel, hard, gray, wet	483.0	 <p style="text-align: center;">12" BOREHOLE</p> <p style="text-align: center;">CEMENT/ BENTONITE GROUT</p>	7SS	X	>100	0.2	
37.5	GP-GRAVEL, subrounded to subangular gravel, medium to coarse grained, trace fine grained sand, trace silt and clay, calcareous cement, very dense to extremely dense, brown sand and gray gravel, blue gray to gray with depth			8SS	X	73	0.2	
40.0				9SS	X	>100	0.2	
42.5		10SS		X	>100	0.2		
45.0					11SS	X	>100	0.2
47.5								
50.0								
52.5								
55.0	END OF HOLE ● 54.2 FT. BGS	466.8						
57.5	NOTES: 1. Stratigraphy for MW-26S taken from pilot hole (MW-26Sa) which was augered to 54.2 ft BGS and grouted to ground surface. 2. Installed MW-26S to a depth of 11.0 ft BGS.							
60.0								
62.5								
65.0								

SCREEN DETAILS:
 Screened interval:
 6.0 to 11.0' BGS
 Length -5.0'
 Diameter -4.0"
 Slot # 10
 Material -Plastic
 Sand pack interval:
 4.0 to 12.0' BGS
 Material -# 4 Quartzite

NOTES: MEASURING POINT ELEVATIONS MAY CHANGE; REFER TO CURRENT ELEVATION TABLE
 GRAIN SIZE ANALYSIS ○ WATER FOUND ∇ STATIC WATER LEVEL ▼

STRATIGRAPHIC AND INSTRUMENTATION LOG (OVERBURDEN)

(L-09)

PROJECT NAME: NEPERA - PLANT SITE
 PROJECT NO.: 3697
 CLIENT: NEPERA, INC.
 LOCATION: HARRIMAN, NY

HOLE DESIGNATION: MW-26D-91
 (Page 1 of 9)
 DATE COMPLETED: AUGUST 2, 1991
 DRILLING METHOD: 4 1/4" ID HSA
 CRA SUPERVISOR: R. FIELD

DEPTH ft BGS	STRATIGRAPHIC DESCRIPTION & REMARKS	ELEVATION ft AMSL	MONITOR INSTALLATION	SAMPLE				
				NUMBER	DATE	ANALYSIS	CONC.	
	REFERENCE ELEVATION (Top of Riser) GROUND SURFACE	523.83 521.2	<p style="font-size: small;"> CONCRETE SEAL CEMENT/BENTONITE GROUT 4" PVC CASING 2" PVC CASING CEMENT/BENTONITE GROUT 8" BOREHOLE </p>					
	For stratigraphy see MW-26S.							
-2.5								
-5.0								
-7.5								
-10.0								
-12.5								
-15.0								
-17.5								
-20.0								
-22.5								
-25.0								
-27.5								
-30.0								
-32.5								

NOTES: MEASURING POINT ELEVATIONS MAY CHANGE; REFER TO CURRENT ELEVATION TABLE

GRAIN SIZE ANALYSIS ○ WATER FOUND ∇ STATIC WATER LEVEL ▼

STRATIGRAPHIC AND INSTRUMENTATION LOG (OVERBURDEN)

(L-09)

PROJECT NAME: NEPERA -- PLANT SITE
 PROJECT NO.: 3697
 CLIENT: NEPERA, INC.
 LOCATION: HARRIMAN, NY

HOLE DESIGNATION: MW-26D-91
 (Page 2 of 9)
 DATE COMPLETED: AUGUST 2, 1991
 DRILLING METHOD: 4 1/4" ID HSA
 CRA SUPERVISOR: R. FIELD

DEPTH ft BGS	STRATIGRAPHIC DESCRIPTION & REMARKS	ELEVATION ft AMSL	MONITOR INSTALLATION	SAMPLE			
				NUMBER	STATE	VALUE	HNU (ppm)
35.0							
37.5							
40.0			5" BOREHOLE				
42.5			2" PVC CASING				
45.0							
47.5							
50.0			CEMENT/ BENTONITE GROUT				
52.5							
55.0							
57.5			4" PVC CASING				
60.0							
62.5							
65.0							

NOTES: MEASURING POINT ELEVATIONS MAY CHANGE; REFER TO CURRENT ELEVATION TABLE

GRAIN SIZE ANALYSIS ○ WATER FOUND ∇ STATIC WATER LEVEL ▼

STRATIGRAPHIC AND INSTRUMENTATION LOG (OVERBURDEN)

(L-09)

PROJECT NAME: NEPERA -- PLANT SITE

HOLE DESIGNATION: MW-26D-91

PROJECT NO.: 3697

DATE COMPLETED: (Page 3 of 9)
AUGUST 2, 1991

CLIENT: NEPERA, INC.

DRILLING METHOD: 4 1/4" ID HSA

LOCATION: HARRIMAN, NY

CRA SUPERVISOR: R. FIELD

DEPTH ft BGS	STRATIGRAPHIC DESCRIPTION & REMARKS	ELEVATION ft AMSL	MONITOR INSTALLATION	SAMPLE			
				NUMBER	STATE	VALUE	HNU (ppm)
67.5			<p style="margin-left: 20px;">8" BOREHOLE</p> <p style="margin-left: 20px;">2" PVC CASING</p> <p style="margin-left: 20px;">CEMENT/ BENTONITE GROUT</p> <p style="margin-left: 20px;">4" PVC CASING</p>				
70.0							
72.5							
75.0							
77.5							
80.0							
82.5							
85.0							
87.5							
90.0							
92.5							
95.0							
97.5							

NOTES: MEASURING POINT ELEVATIONS MAY CHANGE; REFER TO CURRENT ELEVATION TABLE

GRAIN SIZE ANALYSIS ○

WATER FOUND ∇

STATIC WATER LEVEL ▽

STRATIGRAPHIC AND INSTRUMENTATION LOG (OVERBURDEN)

(L-09)

PROJECT NAME: NEPERA - PLANT SITE

HOLE DESIGNATION: MW-26D-91
(Page 4 of 9)
DATE COMPLETED: AUGUST 2, 1991

PROJECT NO.: 3697

CLIENT: NEPERA, INC.

DRILLING METHOD: 4 1/4" ID HSA

LOCATION: HARRIMAN, NY

CRA SUPERVISOR: R. FIELD

DEPTH ft BGS	STRATIGRAPHIC DESCRIPTION & REMARKS	ELEVATION ft AMSL	MONITOR INSTALLATION	SAMPLE			
				NUMBER	STATE	VALUE	UNITS (ppm)
-100.0							
-102.5			8" BOREHOLE				
-105.0			CEMENT/ BENTONITE GROUT				
-107.5							
-110.0	END OF OVERBURDEN HOLE ● 110.5 FT. BGS	410.6	4" PVC CASING				
-112.5							
-115.0			2" PVC CASING				
-117.5							
-120.0			BENTONITE PELLET SEAL				
-122.5							
-125.0			3.9" BOREHOLE				
-127.5			SAND PACK				
-130.0							

NOTES: MEASURING POINT ELEVATIONS MAY CHANGE; REFER TO CURRENT ELEVATION TABLE

GRAIN SIZE ANALYSIS ○ WATER FOUND ∇ STATIC WATER LEVEL ▼

STRATIGRAPHIC AND INSTRUMENTATION LOG (BEDROCK)

(L-10)

PROJECT NAME: NEPERA PLANT - SITE
 PROJECT NO.: 3697
 CLIENT: NEPERA, INC.
 LOCATION: HARRIMAN, NY

HOLE DESIGNATION: MW-26D-91
 (Page 5 of 9)
 DATE COMPLETED: AUGUST 2, 1991
 DRILLING METHOD: HSA / NX CORE
 CRA SUPERVISOR: R. FIELD

DEPTH	DESCRIPTION OF STRATA	ELEVATION	MONITOR INSTALLATION	BI EN DT RE OR CY CAL	RN UN BE R	CR RE CO VE RY	RO D	WR AT TE UR N	
ft BGS		ft. AMSL				%	%	%	
110.0	DOLOMITE (Wappingers Formation): dark gray, fine grained - highly fractured (110.5 to 117.0 ft BGS) - veins of calcite throughout, slight staining (114.8 to 117.0 ft BGS) - slightly weathered iron stained fracturers (● 118.0, 119.0, 120.0 and 120.5 ft BGS) - solution cavity (121.2 ft BGS) - calcite lined fracture, 40° angle (122.5 and 124.0 ft BGS) - fracture (● 128.4 ft BGS) - fracture (● 129.0 ft BGS) - fracture (● 133.5 ft BGS)	410.7	8" BOREHOLE						
112.5			CEMENT/ BENTONITE GROUT	1	100	0			
115.0			2" PVC CASING	2	100	33			
117.5			4" PVC CASING						
120.0			BENTONITE PELLET SEAL	3	100	83			
122.5			SAND PACK						
125.0			3.9" BOREHOLE						
127.5				4	100	97	100		
130.0									
132.5				5	100	47	100		
135.0									
137.5			WELL SCREEN	6	100	100	100		

NOTES: MEASURING POINT ELEVATIONS MAY CHANGE; REFER TO CURRENT ELEVATION TABLE
 ☒ WATER FOUND ☒ STATIC WATER LEVEL NM - NOT MEASURED

STRATIGRAPHIC AND INSTRUMENTATION LOG (BEDROCK)

(L-10)

PROJECT NAME: NEPERA PLANT - SITE
 PROJECT NO.: 3697
 CLIENT: NEPERA, INC.
 LOCATION: HARRIMAN, NY

HOLE DESIGNATION: MW-26D-91
 (Page 6 of 9)
 DATE COMPLETED: AUGUST 2, 1991
 DRILLING METHOD: HSA / NX CORE
 CRA SUPERVISOR: R. FIELD

DEPTH	DESCRIPTION OF STRATA	ELEVATION	MONITOR INSTALLATION	BI EN DT RE OR CV KA L	RN UN UM BER	COR RE C O V E R Y	R O D	W R E T U R N
ft BGS		ft. AMSL				%	%	%
-140.0			3.0" BOREHOLE		6	100	100	100
-142.5			WELL SCREEN					
-145.0	- fracture (● 144.3 ft BGS)		SAND PACK					
-147.5	- fracture (● 147.9 ft BGS)		3" NX COREHOLE		7	100	93	100
-150.0	- fracture (● 148.4 ft BGS)							
-152.5	- fracture (● 148.6 ft BGS)							
-155.0	- fracture (● 148.8 ft BGS)							
-157.5	- fracture (● 149.0 ft BGS)							
-160.0	- fracture (● 149.5 ft BGS)							
-162.5	- fracture (● 149.9 ft BGS)							
-165.0	- fracture (● 151.0 ft BGS)							
-167.5	- trace disseminated pyrite (unweathered) (153.0 to 154.5 ft BGS)		CEMENT/ BENTONITE GROUT					
-170.0					8	100	88	100
-172.5	- high angle, highly fractured zone (162.0 to 162.5 ft BGS)							
-175.0								
-177.5								
-180.0	- high angle fracture (● 167.5 ft BGS)				9	77	97	100

NOTES: MEASURING POINT ELEVATIONS MAY CHANGE; REFER TO CURRENT ELEVATION TABLE

☒ WATER FOUND

☒ STATIC WATER LEVEL

NM - NOT MEASURED

STRATIGRAPHIC AND INSTRUMENTATION LOG (BEDROCK)

(L-10)

PROJECT NAME: NEPERA PLANT - SITE
 PROJECT NO.: 3697
 CLIENT: NEPERA, INC.
 LOCATION: HARRIMAN, NY

HOLE DESIGNATION: MW-26D-91
 (Page 7 of 9)
 DATE COMPLETED: AUGUST 2, 1991
 DRILLING METHOD: HSA / NX CORE
 CRA SUPERVISOR: R. FIELD

DEPTH	DESCRIPTION OF STRATA	ELEVATION	MONITOR INSTALLATION	BI EN DT RE OR CV KAL	RN UN MB ER	CR RE CO VE RY	RO D	WE TE R R N	
ft BGS		ft. AMSL				%	%	%	
-170.0	- high angle fracture (● 170.0 ft BGS)								
-172.5	- high angle fracture (● 173.6 ft BGS)								
-175.0	- becomes light gray - high angle fracture (● 175.6 ft BGS)					10	100	100	100
-177.5									
-180.0									
-182.5	- high angle fracture, calcite filled vugs (● 183.0 ft BGS)								
-185.0	- high angle fracture (● 184.2 ft BGS)					11	100	92	100
-187.5	- high angle fracture (● 185.8 ft BGS)								
-190.0									
-192.5									
-195.0	- becomes dark gray								
-197.5	- calcite deposits in fracture (● 196.3 ft. BGS) - calcite deposits in fracture					12	100	92	100

NOTES: MEASURING POINT ELEVATIONS MAY CHANGE; REFER TO CURRENT ELEVATION TABLE
 ☒ WATER FOUND ☒ STATIC WATER LEVEL NM - NOT MEASURED

STRATIGRAPHIC AND INSTRUMENTATION LOG (BEDROCK)

(L-10)

PROJECT NAME: NEPERA PLANT - SITE
 PROJECT NO.: 3697
 CLIENT: NEPERA, INC.
 LOCATION: HARRIMAN, NY

HOLE DESIGNATION: MW-26D-91
 (Page 8 of 9)
 DATE COMPLETED: AUGUST 2, 1991
 DRILLING METHOD: HSA / NX CORE
 CRA SUPERVISOR: R. FIELD

DEPTH	DESCRIPTION OF STRATA	ELEVATION	MONITOR INSTALLATION	BI ENT RECOR CAL	RN UN RMB	CR RECOVERY	ROD	WATER
ft BGS		ft AMSL				%	%	%
-200.0	- light gray, fine grained, pyrite deposits and calcite filled vugs (● 201.0 ft BGS)							
-202.5								
-205.0	- highly fractured (204.7 to 205.3 ft BGS)							
-207.5								
-210.0								
-212.5								
-215.0	- calcite healed fracture and large vug (● 215.0 ft BGS)							
-217.5								
-220.0								
-222.5								
-225.0								
-227.5								

NOTES: MEASURING POINT ELEVATIONS MAY CHANGE; REFER TO CURRENT ELEVATION TABLE
 ☒ WATER FOUND ☒ STATIC WATER LEVEL NM - NOT MEASURED

**STRATIGRAPHIC AND INSTRUMENTATION LOG
(BEDROCK)**

(L-10)

PROJECT NAME: NEPERA PLANT - SITE
 PROJECT NO.: 3697
 CLIENT: NEPERA, INC.
 LOCATION: HARRIMAN, NY

HOLE DESIGNATION: MW-26D-91
 (Page 9 of 9)
 DATE COMPLETED: AUGUST 2, 1991
 DRILLING METHOD: HSA / NX CORE
 CRA SUPERVISOR: R. FIELD

DEPTH	DESCRIPTION OF STRATA	ELEVATION	MONITOR INSTALLATION	BI END DT RE OR CV K AL	RN U N B E R	CR O E C O V E R Y	R O D	WR A T E R R N
ft BGS		ft. AMSL				%	%	%
-230.0					17	100	96	100
-232.5								
-235.0								
-237.5					18	100	100	100
-240.0								
-242.5								
-245.0	END OF HOLE ● 243.5 FT. BGS	277.7						
-247.5								
-250.0								
-252.5								
-255.0								
-257.5								

NOTES: MEASURING POINT ELEVATIONS MAY CHANGE; REFER TO CURRENT ELEVATION TABLE

Σ WATER FOUND

Σ STATIC WATER LEVEL



NM - NOT MEASURED



STRATIGRAPHIC AND INSTRUMENTATION LOG (OVERBURDEN)

(L-11)

PROJECT NAME: NEPERA - PLANT SITE
 PROJECT NO.: 3697
 CLIENT: NEPERA, INC.
 LOCATION: HARRIMAN, NY

HOLE DESIGNATION: MW-275-91
 (Page 1 of 2)
 DATE COMPLETED: JULY 26, 1991
 DRILLING METHOD: 6 1/4" ID HSA
 CRA SUPERVISOR: R. FIELD

DEPTH ft BGS	STRATIGRAPHIC DESCRIPTION & REMARKS	ELEVATION ft AMSL	MONITOR INSTALLATION	SAMPLE			
				NUMBER	STATE	VALUE	UNITS
	REFERENCE ELEVATION (Top of Riser) GROUND SURFACE	535.78 533.8					
	For stratigraphy see stratigraphic log MW-27D.						
-2.5			CONCRETE SEAL				
-5.0							
-7.5							
-10.0			12" BOREHOLE				
-12.5			CEMENT/ BENTONITE GROUT				
-15.0							
-17.5		516.9	4" PVC CASING				
-20.0							
-22.5			BENTONITE PELLET SEAL				
-25.0			SAND PACK				
-27.5							
-30.0							
-32.5			WELL SCREEN				

NOTES: MEASURING POINT ELEVATIONS MAY CHANGE; REFER TO CURRENT ELEVATION TABLE
 GRAIN SIZE ANALYSIS  WATER FOUND  STATIC WATER LEVEL 

STRATIGRAPHIC AND INSTRUMENTATION LOG (OVERBURDEN)

(L-11)

PROJECT NAME: NEPERA - PLANT SITE
 PROJECT NO.: 3697
 CLIENT: NEPERA, INC.
 LOCATION: HARRIMAN, NY

HOLE DESIGNATION: MW-27S-91
 (Page 2 of 2)
 DATE COMPLETED: JULY 26, 1991
 DRILLING METHOD: 6 1/4" ID HSA
 CRA SUPERVISOR: R. FIELD

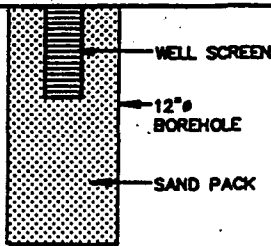
DEPTH ft BGS	STRATIGRAPHIC DESCRIPTION & REMARKS	ELEVATION ft AMSL	MONITOR INSTALLATION	SAMPLE			
				NUMBER	SITE	VALUE	HNB (ppm)
35.0			 <p style="margin-left: 20px;">WELL SCREEN 12" BOREHOLE SAND PACK</p> <p>SCREEN DETAILS: Screened Interval: 30.0 to 35.0' BGS Length -5.0' Diameter -4.0" Slot # 10 Material -Plastic Sand pack interval: 24.0 to 39.0' BGS Material -# 4 Quartzite</p>				
37.5							
40.0	END OF HOLE ● 39.0 FT. BGS	494.8					
42.5							
45.0							
47.5							
50.0							
52.5							
55.0							
57.5							
60.0							
62.5							
65.0							

NOTES: MEASURING POINT ELEVATIONS MAY CHANGE; REFER TO CURRENT ELEVATION TABLE

GRAIN SIZE ANALYSIS ○ WATER FOUND ∑ STATIC WATER LEVEL ▼

STRATIGRAPHIC AND INSTRUMENTATION LOG (OVERBURDEN)

(L-12)

PROJECT NAME: NEPERA - PLANT SITE
 PROJECT NO.: 3697
 CLIENT: NEPERA, INC.
 LOCATION: HARRIMAN, NY

HOLE DESIGNATION: MW-270-91
 (Page 1 of 4)
 DATE COMPLETED: JULY 27, 1991
 DRILLING METHOD: 4 1/4" ID HSA
 CRA SUPERVISOR: R. FIELD

DEPTH ft BGS	STRATIGRAPHIC DESCRIPTION & REMARKS	ELEVATION ft AMSL	MONITOR INSTALLATION	SAMPLE			
				NUMBER	STATE	VALUE	UNITS
	REFERENCE ELEVATION (Top of Riser) GROUND SURFACE	535.26 533.7					
2.5	SM-SAND, fine grained, little silt, trace cobbles, medium dense, brown, moist		CONCRETE SEAL				
5.0	ML-SILT, little very fine grained sand, very stiff, brown, mottled, moist	528.9 528.1		1SS	X	21	0.4
7.5	SP-SAND, fine grained, trace silt, medium dense, brown with gold specs, moist		4" PVC CASING				
10.0	ML-SILT, interbedded with clay seams and sand lenses, firm to hard, brown, moist to wet	525.7		2SS	X	21	0.3
12.5	- becomes gray		8" BOREHOLE				
15.0				3SS	X	32	0.5
17.5		516.7					
20.0			CEMENT/BENTONITE GROUT	4SS	X	8	0.7
22.5							
25.0	SM-SAND, very fine grained, little silt, loose, gray, saturated	508.2 507.2		5SS	X	4	0.6
27.5	SP-SAND, very fine to fine grained, trace silt, loose to dense, dark gray, saturated						
30.0				6SS	X	2	0.6
32.5							

NOTES: MEASURING POINT ELEVATIONS MAY CHANGE; REFER TO CURRENT ELEVATION TABLE

GRAIN SIZE ANALYSIS ○ WATER FOUND ∇ STATIC WATER LEVEL ▼

STRATIGRAPHIC AND INSTRUMENTATION LOG (OVERBURDEN)

(L-12)

PROJECT NAME: NEPERA - PLANT SITE

HOLE DESIGNATION: MW-27D-91

PROJECT NO.: 3697

DATE COMPLETED: JULY 27, 1991
(Page 2 of 4)

CLIENT: NEPERA, INC.

DRILLING METHOD: 4 1/4" ID HSA

LOCATION: HARRIMAN, NY

CRA SUPERVISOR: R. FIELD

DEPTH ft BGS	STRATIGRAPHIC DESCRIPTION & REMARKS	ELEVATION ft AMSL	MONITOR INSTALLATION	SAMPLE			
				NUMBER	STATE	VALUE	HN
35.0				7SS	X	37	0.4
37.5	ML-SILT(TILL), some fine grained subrounded to subangular gravel, little fine grained sand, trace to little clay, very dense, gray, moist	495.7	4" PVC CASING				
40.0				8SS	X	64	0.3
42.5							
45.0				9SS	X	>100	-
47.5							
50.0			CEMENT/ BENTONITE GROUT	10SS	X	>100	0.4
52.5							
55.0			8" BOREHOLE	11SS	X	>100	-
57.5							
60.0							
62.5							
65.0				12SS	X	>100	-

NOTES: MEASURING POINT ELEVATIONS MAY CHANGE; REFER TO CURRENT ELEVATION TABLE

GRAIN SIZE ANALYSIS ○ WATER FOUND ∇ STATIC WATER LEVEL ▼

STRATIGRAPHIC AND INSTRUMENTATION LOG (OVERBURDEN)

(L-12)

PROJECT NAME: NEPERA - PLANT SITE
 PROJECT NO.: 3697
 CLIENT: NEPERA, INC.
 LOCATION: HARRIMAN, NY

HOLE DESIGNATION: MW-27D-91
 (Page 3 of 4)
 DATE COMPLETED: JULY 27, 1991
 DRILLING METHOD: 4 1/4" ID HSA
 CRA SUPERVISOR: R. FIELD

DEPTH ft BGS	STRATIGRAPHIC DESCRIPTION & REMARKS	ELEVATION ft AMSL	MONITOR INSTALLATION	SAMPLE			
				NUM.	STATE	VALUE	HNU
-67.5							
-70.0							
-72.5							
-75.0	END OF OVERBURDEN HOLE @ 74.0 FT. BGS	459.7					
-77.5							
-80.0							
-82.5							
-85.0							
-87.5							
-90.0							
-92.5							
-95.0							
-97.5							

NOTES: MEASURING POINT ELEVATIONS MAY CHANGE; REFER TO CURRENT ELEVATION TABLE
 GRAIN SIZE ANALYSIS ○ WATER FOUND ∑ STATIC WATER LEVEL ▼

STRATIGRAPHIC AND INSTRUMENTATION LOG (BEDROCK)

(L-13)

PROJECT NAME: NEPERA - PLANT SITE
 PROJECT NO.: 3697
 CLIENT: NEPERA, INC.
 LOCATION: HARRIMAN, NY

HOLE DESIGNATION: MW-27D-91
 (Page 4 of 4)
 DATE COMPLETED: JULY 27, 1991
 DRILLING METHOD: HSA / NX CORE
 CRA SUPERVISOR: R. FIELD

DEPTH	DESCRIPTION OF STRATA	ELEVATION	MONITOR INSTALLATION	BI EN DT RE OR CV KA L	RN U N B E R	CR E C O V E R Y	R O D	WR E T T E R N	
ft BGS		ft. AMSL				%	%	%	
72.5		459.7							
75.0	DOLOMITE (Wappingers Formation): gray, fine grained - weathered, rough and irregular surfaced fracture (● 74.5 ft BGS) - high angle fracture (● 75.0 ft BGS) - high angle fracture (● 75.5 ft BGS) - high angle fracture (● 76.5 ft BGS) - weathered, rough and irregular surfaced fracture (● 76.8 ft BGS) - weathered, rough and irregular surfaced fracture (● 77.2 ft BGS) - weathered, rough and irregular surfaced fracture (● 77.8 ft BGS) - fracture (● 79.8 ft BGS) - fracture (● 80.2 ft BGS) - fracture (● 81.2 ft BGS) - high angle fracture (● 81.6 ft BGS) - high angle fracture (● 82.6 ft BGS) - high angle fracture (● 84.1 ft BGS) - high angle fracture (● 84.5 ft BGS) - high angle fracture (● 85.0 ft BGS) - high angle fracture (● 85.9 ft BGS) - high angle fracture (● 86.6 ft BGS) - high angle fracture (● 87.6 ft BGS) - high angle fracture (● 88.3 ft BGS) - irregular surfaced fracture (● 89.5 ft BGS) - irregular surfaced fracture (● 90.4 ft BGS) - irregular surfaced fracture (● 90.8 ft BGS)			1	80	87			
77.5									
80.0									
82.5									
85.0						2	96	81	
87.5									
90.0									
92.5									
95.0						3	100	80	
97.5									
100.0	- irregular surfaced fracture (● 96.3 ft BGS) - weathered calcite fracture (● 93.7 ft BGS) - (1cm) calcite filled vug (● 94.0 ft BGS) - weathered calcite fracture (● 94.2 ft BGS) - high angle fracture (● 95.7 ft BGS) - high angle fracture (● 96.0 ft BGS) - high angle fracture (● 97.6 ft BGS) END OF HOLE ● 99 FT. BGS	434.7							

NOTES: MEASURING POINT ELEVATIONS MAY CHANGE; REFER TO CURRENT ELEVATION TABLE
 ∑ WATER FOUND ∞ STATIC WATER LEVEL NM - NOT MEASURED

STRATIGRAPHIC AND INSTRUMENTATION LOG (OVERBURDEN)

(L-14)

PROJECT NAME: NEPERA - PLANT SITE

HOLE DESIGNATION: MW-27D-92
(Page 1 of 5)

PROJECT NO.: 3697

DATE COMPLETED: APRIL 15, 1992

CLIENT: NEPERA, INC.

DRILLING METHOD: MUD ROTARY / AIR

LOCATION: HARRIMAN, NY

CRA SUPERVISOR: B. WELSEK

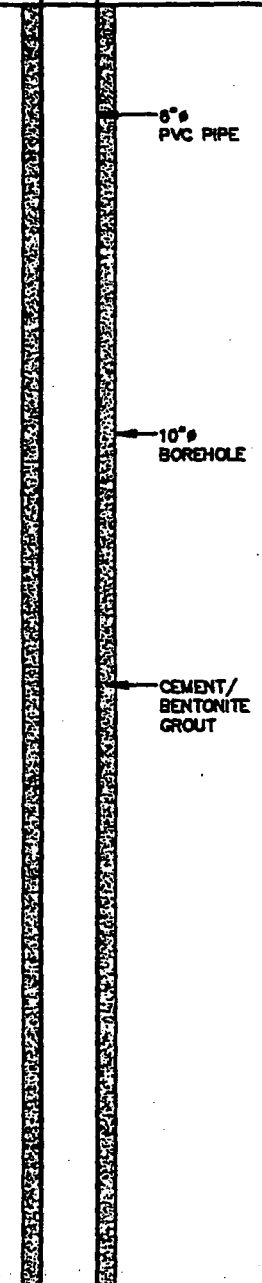
DEPTH ft BGS	STRATIGRAPHIC DESCRIPTION & REMARKS	ELEVATION ft AMSL	MONITOR INSTALLATION	SAMPLE			
				NUMBER	STATE	VALUE	O V A (ppm)
	REFERENCE ELEVATION (Top of Riser) GROUND SURFACE	536.20 533.7					
	For overburden stratigraphy see log MW-27D NOTES: 1. MW-27D-92 replaces MW-27D-91 which became blocked.						
-2.5							
-5.0							
-7.5							
-10.0							
-12.5							
-15.0							
-17.5							
-20.0							
-22.5							
-25.0							
-27.5							
-30.0							
-32.5							

NOTES: MEASURING POINT ELEVATIONS MAY CHANGE; REFER TO CURRENT ELEVATION TABLE

CHEMICAL ANALYSIS  WATER FOUND  STATIC WATER LEVEL 

STRATIGRAPHIC AND INSTRUMENTATION LOG (OVERBURDEN)

(L-14)

PROJECT NAME: NEPERA - PLANT SITE

HOLE DESIGNATION: MW-27D-92
(Page 2 of 5)

PROJECT NO.: 3697

DATE COMPLETED: APRIL 15, 1992

CLIENT: NEPERA, INC.

DRILLING METHOD: MUD ROTARY / AIR

LOCATION: HARRIMAN, NY

CRA SUPERVISOR: B. WELSEK

DEPTH ft BGS	STRATIGRAPHIC DESCRIPTION & REMARKS	ELEVATION ft AMSL	MONITOR INSTALLATION	SAMPLE			
				NUMBER	STATE	VALUE	O V A (ppm)
35.0 37.5 40.0 42.5 45.0 47.5 50.0 52.5 55.0 57.5 60.0 62.5 65.0							

NOTES: MEASURING POINT ELEVATIONS MAY CHANGE; REFER TO CURRENT ELEVATION TABLE

CHEMICAL ANALYSIS ○

WATER FOUND ∇

STATIC WATER LEVEL ▼

STRATIGRAPHIC AND INSTRUMENTATION LOG (OVERBURDEN)

(L-14)

PROJECT NAME: NEPERA -- PLANT SITE

HOLE DESIGNATION: MW-27D-92

PROJECT NO.: 3697

DATE COMPLETED: APRIL 15, 1992
(Page 3 of 5)

CLIENT: NEPERA, INC.

DRILLING METHOD: MUD ROTARY / AIR

LOCATION: HARRIMAN, NY

CRA SUPERVISOR: B. WELSEK

DEPTH ft BGS	STRATIGRAPHIC DESCRIPTION & REMARKS	ELEVATION ft AMSL	MONITOR INSTALLATION	SAMPLE			
				NUMBER	STATE	VALUE	O V A (ppm)
67.5			6" PVC PIPE				
70.0	BEDROCK END OF OVERBURDEN HOLE ● 69.5 FT. BGS	464.2	CEMENT/ BENTONITE GROUT				
72.5			10" BOREHOLE				
75.0			BENTONITE PELLET SEAL				
77.5			6" BOREHOLE				
80.0							
82.5							
85.0							
87.5							
90.0							
92.5							
95.0							
97.5							

NOTES: MEASURING POINT ELEVATIONS MAY CHANGE; REFER TO CURRENT ELEVATION TABLE

CHEMICAL ANALYSIS ○

WATER FOUND ◻

STATIC WATER LEVEL ▼

**STRATIGRAPHIC AND INSTRUMENTATION LOG
(BEDROCK)**

(L-15)

PROJECT NAME: NEPERA - PLANT SITE

HOLE DESIGNATION: MW-27D-92
(Page 4 of 5)

PROJECT NO.: 3697

DATE COMPLETED: APRIL 15, 1992

CLIENT: NEPERA, INC.

DRILLING METHOD: MUD ROTARY / AIR

LOCATION: HARRIMAN, NY

CRA SUPERVISOR: B. WELSEK

DEPTH	DESCRIPTION OF STRATA	ELEVATION	MONITOR INSTALLATION	BI EN DT RE OR CV KA L	RN UM BER	CR EC O V E R Y	RO D	WA TE R R N
ft BGS		ft. AMSL				%	%	%
67.5	Overburden	464.2	<p>6" PVC PIPE</p> <p>CEMENT/ BENTONITE GROUT</p> <p>10" BOREHOLE</p> <p>BENTONITE PELLET SEAL</p> <p>6" BOREHOLE</p>					
70.0	For bedrock stratigraphy see log MW-27D							
72.5								
75.0								
77.5								
80.0								
82.5								
85.0								
87.5								
90.0								
92.5								
95.0								

NOTES: MEASURING POINT ELEVATIONS MAY CHANGE; REFER TO CURRENT ELEVATION TABLE

☒ WATER FOUND

☒ STATIC WATER LEVEL

NM - NOT MEASURED

STRATIGRAPHIC AND INSTRUMENTATION LOG (BEDROCK)

(L-15)

PROJECT NAME: NEPERA - PLANT SITE

HOLE DESIGNATION: MW-27D-92
(Page 5 of 5)

PROJECT NO.: 3697

DATE COMPLETED: APRIL 15, 1992

CLIENT: NEPERA, INC.

DRILLING METHOD: MUD ROTARY / AIR

LOCATION: HARRIMAN, NY

CRA SUPERVISOR: B. WELSEK

DEPTH	DESCRIPTION OF STRATA	ELEVATION	MONITOR INSTALLATION	BI D R E C T O R Y K A L	RN U M B E R	CR O S S C O V E R Y	R O D	W R E T U R N
ft BGS		ft. AMSL				%	%	%
97.5			<div style="border: 1px solid black; width: 30px; height: 20px; margin: 0 auto;"></div> <p style="text-align: center;">← 6" BOREHOLE</p>					
100.0	END OF HOLE ● 99 FT. BGS	434.7						
102.5								
105.0								
107.5								
110.0								
112.5								
115.0								
117.5								
120.0								
122.5								
125.0								

NOTES: MEASURING POINT ELEVATIONS MAY CHANGE; REFER TO CURRENT ELEVATION TABLE

☒ WATER FOUND

☒ STATIC WATER LEVEL

NM - NOT MEASURED



THE
FOLLOWING
DOCUMENTS
WERE OF
POOR
QUALITY

IMAGE
DATA

A Data Distributors Company

P2-1 - P2-4

STRATIGRAPHIC AND INSTRUMENTATION LOG (OVERBURDEN)

(L-31)

PROJECT NAME: NEPERA - PLANT SITE
 PROJECT NO.: 3697
 CLIENT: NEPERA, INC.
 LOCATION: HARRIMAN, NY

HOLE DESIGNATION: PZ-1
 (Page 2 of 2)
 DATE COMPLETED: JULY 15, 1991
 DRILLING METHOD: 4 1/4" ID HSA
 CRA SUPERVISOR: R. FIELD

DEPTH ft BGS	STRATIGRAPHIC DESCRIPTION & REMARKS	ELEVATION ft AMSL	MONITOR INSTALLATION	SAMPLE			
				NUMBER	STATE	VALUE	HNU (ppm)
35.0 37.5 40.0 42.5 45.0 47.5 50.0 52.5 55.0 57.5 60.0 62.5 65.0	END OF HOLE @ 35.0 FT. BGS NOTES: 1. Installed PZ-1 to a depth of 32.0 ft BGS.	507.5	 <p> SAND PACK 5" BOREHOLE </p> <p> <u>SCREEN DETAILS:</u> Screened Interval: 27.0 to 32.0' BGS Length -5.0' Diameter -2.0" Slot # 10 Material -Plastic Sand pack interval: 24.0 to 35.0' BGS Material -# 4 Quartzite </p>	7SS	X	81	0.2

NOTES: MEASURING POINT ELEVATIONS MAY CHANGE; REFER TO CURRENT ELEVATION TABLE
 GRAIN SIZE ANALYSIS ○ WATER FOUND ∇ STATIC WATER LEVEL ▼

STRATIGRAPHIC AND INSTRUMENTATION LOG (OVERBURDEN)

(L-02)

PROJECT NAME: NEPERA - PLANT SITE
 PROJECT NO.: 3697
 CLIENT: NEPERA, INC.
 LOCATION: HARRIMAN, NY

HOLE DESIGNATION: PZ-2
 (Page 1 of 2)
 DATE COMPLETED: JULY 9, 1991
 DRILLING METHOD: 4 1/4" ID HSA
 CRA SUPERVISOR: R. FIELD

DEPTH ft BGS	STRATIGRAPHIC DESCRIPTION & REMARKS	ELEVATION ft AMSL	MONITOR INSTALLATION	SAMPLE			
				NUMBER	STATE	VALUE	H NU (ppm)
	REFERENCE ELEVATION (Top of Riser) GROUND SURFACE	532.54 532.9					
	Asphalt	530.9	ROAD BOX				
	SM-SAND(FILL), some silt and gravel, dark brown	528.9	CONCRETE SEAL				
-2.5	ML-SILT(FILL), some very fine grained sand, trace clay, medium dense to extremely dense, gray, moist	525.9		1SS	X	18	2.1
-5.0	SM-SAND, very fine grained, little silt, gray to greenish gray, moist						
-7.5							
-10.0	- medium grained gravel seam, black (9.5 to 9.8 ft BGS)	524.0 523.8		2SS	X	14	0.3
-12.5			8" BOREHOLE				
-15.0				3SS	X	14	0.3
-17.5	- fine grained SP-SAND seam, gray (18.0 to 18.5 ft BGS)		2" PVC CASING				
-20.0			CEMENT/BENTONITE GROUT	4SS	X	28	0.3
-22.5	SM-SAND, fine to medium grained, some silt, some gravel, trace clay, calcareous cement, extremely dense, brown to gray, moist to wet	511.9		5SS	X	>100	0.3
-25.0							
-27.5							
-30.0				6SS	X	>100	0.3
-32.5							

NOTES: MEASURING POINT ELEVATIONS MAY CHANGE; REFER TO CURRENT ELEVATION TABLE

GRAIN SIZE ANALYSIS ○ WATER FOUND ▽ STATIC WATER LEVEL ▽

STRATIGRAPHIC AND INSTRUMENTATION LOG (OVERBURDEN)

(L-02)

PROJECT NAME: NEPERA - PLANT SITE
 PROJECT NO.: 3697
 CLIENT: NEPERA, INC.
 LOCATION: HARRIMAN, NY

HOLE DESIGNATION: PZ-2
 (Page 2 of 2)
 DATE COMPLETED: JULY 9, 1991
 DRILLING METHOD: 4 1/4" ID HSA
 CRA SUPERVISOR: R. FIELD

DEPTH ft BGS	STRATIGRAPHIC DESCRIPTION & REMARKS	ELEVATION ft AMSL	MONITOR INSTALLATION	SAMPLE			
				NUMBER	STATE	VALUE (ppm)	HNG
35.0				7SS	X	>100	0.3
37.5				8SS	X	>100	0.3
40.0				9SS	X	>100	-
42.5	SM-SAND, fine grained, trace silt, trace gravel, trace white calcareous cement, extremely dense, dark gray to black, wet			10SS	X	>100	0.2
45.0					11SS	X	>100
47.5	- clay lense, wet			12SS	X	>100	-
50.0							
52.5							
55.0	- fine grained sand seam, black, saturated	477.6					
57.5	END OF HOLE @ 55.3 FT. BGS NOTES: 1. Installed PZ-2 to a depth of 53.0 ft BGS.						
60.0							
62.5							
65.0							

SCREEN DETAILS:
 Screened Interval:
 48.0 to 53.0' BGS
 Length - 5.0'
 Diameter - 2.0"
 Slot # 10
 Material - Plastic
 Sand pack interval:
 43.0 to 55.3' BGS
 Material - # 4 Quartzite

NOTES: MEASURING POINT ELEVATIONS MAY CHANGE; REFER TO CURRENT ELEVATION TABLE
 GRAIN SIZE ANALYSIS ○ WATER FOUND X STATIC WATER LEVEL ▼

STRATIGRAPHIC AND INSTRUMENTATION LOG (OVERBURDEN)

(L-03)

PROJECT NAME: NEPERA - PLANT SITE
 PROJECT NO.: 3697
 CLIENT: NEPERA, INC.
 LOCATION: HARRIMAN, NY

HOLE DESIGNATION: PZ-3
 (Page 1 of 2)
 DATE COMPLETED: JULY 22, 1991
 DRILLING METHOD: 4 1/4" ID HSA
 CRA SUPERVISOR: R. FIELD

DEPTH ft BGS	STRATIGRAPHIC DESCRIPTION & REMARKS	ELEVATION ft AMSL	MONITOR INSTALLATION	SAMPLE				
				NUMBER	STATE	VALUE (ppm)	H N G	
	REFERENCE ELEVATION (Top of Riser) GROUND SURFACE	526.17 526.5						
2.5	Asphalt Class 5 gravel ML-SILT, trace very fine grained sand, very stiff, interbedded white and black color, moist	526.0		1SS	X	17	1.5	
5.0								
7.5	CL-CLAY, some silt, firm, brown to black, wet	520.5 519.8			2SS	X	4	0.3
10.0		516.6						
12.5	ML-SILT, trace clay, very stiff, gray, wet	513.5			3SS	X	24	2.5
15.0								
17.5	CL-CLAY, some silt, soft, gray, wet	509.5			4SS	X	2	0.3
20.0								
22.5	ML-SILT, trace clay, very stiff, gray, saturated	505.5			5SS	X	21	1
25.0	SP-SAND, fine to medium grained, little fine gravel, medium dense, gray, saturated	501.5 500.5						
27.5	GP-GRAVEL, fine grained, some fine to medium grained sand, little silt, trace clay, very dense, saturated			6SS	X	51	1.5	
30.0								
32.5	SP-SAND, medium grained, trace silt, extremely dense, dark gray to black, saturated	495.5						

NOTES: MEASURING POINT ELEVATIONS MAY CHANGE; REFER TO CURRENT ELEVATION TABLE

GRAIN SIZE ANALYSIS ○ WATER FOUND ∇ STATIC WATER LEVEL ▼

STRATIGRAPHIC AND INSTRUMENTATION LOG (OVERBURDEN)

(L-03)

PROJECT NAME: NEPERA - PLANT SITE

HOLE DESIGNATION: PZ-3

PROJECT NO.: 3697



(Page 2 of 2)
DATE COMPLETED: JULY 22, 1991

CLIENT: NEPERA, INC.

DRILLING METHOD: 4 1/4" ID HSA

LOCATION: HARRIMAN, NY

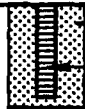
CRA SUPERVISOR: R. FIELD

DEPTH ft BGS	STRATIGRAPHIC DESCRIPTION & REMARKS	ELEVATION ft AMSL	MONITOR INSTALLATION	SAMPLE						
				NUMBER	STATE	VALUE (ppm)	ENG			
35.0			 <p>SAND PACK WELL SCREEN</p>	7SS	X	>100	0.3			
37.5	SM-SAND, fine grained, little silt, trace fine gravel, extremely dense, wet to saturated	489.5	 <p>8" BOREHOLE</p>	8SS	X	>100	0.3			
40.0										
42.5							9SS	X	100	0.3
45.0										
47.5						 <p>CEMENT/ BENTONITE GROUT</p>	10SS	X	100	0.3
50.0										
52.5				11SS	X	100	0.3			
55.0										
57.5	END OF HOLE ● 57.0 FT. BGS	469.5								
60.0	NOTES: 1. Stratigraphy for PZ-3 taken from pilot hole (PZ-3a) which was augered to 57.0 ft BGS and grouted to ground surface. 2. Installed PZ-3 to a depth of 35.0 ft BGS.									
62.5										
65.0										

SCREEN DETAILS:
 Screened Interval:
 30.0 to 35.0' BGS
 Length -5.0'
 Diameter -2.0"
 Slot # 10
 Material -Plastic
 Sand pack interval:
 27.0 to 35.3' BGS
 Material -# 4 Quartzite

NOTES: MEASURING POINT ELEVATIONS MAY CHANGE; REFER TO CURRENT ELEVATION TABLE

GRAIN SIZE ANALYSIS ○ WATER FOUND X STATIC WATER LEVEL ▼

STRATIGRAPHIC AND INSTRUMENTATION LOG (OVERBURDEN)

(L-04)

PROJECT NAME: NEPERA - PLANT SITE
 PROJECT NO.: 3697
 CLIENT: NEPERA, INC.
 LOCATION: HARRIMAN, NY

HOLE DESIGNATION: PZ-4
 (Page 1 of 2)
 DATE COMPLETED: JULY 15, 1991
 DRILLING METHOD: 4 1/4" ID HSA
 CRA SUPERVISOR: R. FIELD

DEPTH ft BGS	STRATIGRAPHIC DESCRIPTION & REMARKS	ELEVATION ft AMSL	MONITOR INSTALLATION	SAMPLE			
				NUMBER	STATE	VALUE	HNU (ppm)
	REFERENCE ELEVATION (Top of Riser) GROUND SURFACE	534.90 532.3					
2.5	SP-SAND(FILL), some silt, little fine to medium gravel, brown, dry		CONCRETE SEAL				
5.0	SM-SAND(FILL), fine to medium grained, some silt, trace clay, trace fine gravel, dark brown to black, dry, black roots	529.3		1SS	X	15	0.3
7.5	- black silty sand seam, slight pyridine odor						
10.0	SC/SM-SAND, some silt and clay, black, wet, slight pyridine odor	522.3		2SS	X	13	5
12.5			2" PVC CASING				
15.0		515.5		3SS	X	12	-
17.5							
20.0	ML-SILT, interbedded clay seams, very soft to stiff, gray, wet	514.3 513.9	CEMENT/ BENTONITE GROUT	4SS	X	10	0.2
22.5							
25.0			8" BOREHOLE	5SS	X	4	0.2
27.5							
30.0				6SS	X	WH	0.5
32.5							

NOTES: MEASURING POINT ELEVATIONS MAY CHANGE; REFER TO CURRENT ELEVATION TABLE

GRAIN SIZE ANALYSIS ○ WATER FOUND ∇ STATIC WATER LEVEL ▼

STRATIGRAPHIC AND INSTRUMENTATION LOG (OVERBURDEN)

(L-04)

PROJECT NAME: NEPERA - PLANT SITE

HOLE DESIGNATION: PZ-4
(Page 2 of 2)

PROJECT NO.: 3697

DATE COMPLETED: JULY 15, 1991

CLIENT: NEPERA, INC.

DRILLING METHOD: 4 1/4" ID HSA

LOCATION: HARRIMAN, NY

CRA SUPERVISOR: R. FIELD

DEPTH ft BGS	STRATIGRAPHIC DESCRIPTION & REMARKS	ELEVATION ft AMSL	MONITOR INSTALLATION	SAMPLE				
				NUMBER	STATE	VALUE	H ₂ O (ppm)	
35.0				7SS	X	WH	0.2	
37.5				8SS	X	11	0.2	
40.0	- very fine grained sandy silt seam							
42.5								
45.0	- very fine grained sandy silt seam				9SS	X	19	0.4
47.5	CL-CLAY, little silt, extremely dense, gray, wet	486.3						
50.0	SM-SAND, very fine grained, little angular gravel, little silt, calcareous cement, extremely dense, gray, saturated	483.3			10SS	X	>100	0.2
52.5								
55.0	SM-SAND, fine to coarse grained, some fine to medium gravel, little silt, trace clay, calcareous cement, extremely dense, gray, saturated	479.3			11SS	X	43	0.2
57.5								
60.0	END OF HOLE ● 59.0 FT. BGS	473.3			12SS	X	77	-
62.5	NOTES: 1. Stratigraphy for PZ-4 taken from pilot hole (PZ-4a) which was augered to 59.0 ft BGS and grouted to ground surface. 2. Installed PZ-4 to a depth of 46.0 ft BGS.							
65.0								

SCREEN DETAILS:
 Screened Interval:
 41.0 to 46.0' BGS
 Length - 5.0'
 Diameter - 2.0"
 Slot # 10
 Material - Plastic
 Sand pack interval:
 37.0 to 47.0' BGS
 Material - # 4 Quartzite

NOTES: MEASURING POINT ELEVATIONS MAY CHANGE; REFER TO CURRENT ELEVATION TABLE

GRAIN SIZE ANALYSIS ○ WATER FOUND X STATIC WATER LEVEL ▽



MW 535/130

WELL CONSTRUCTION LOG
(UNCONSOLIDATED)

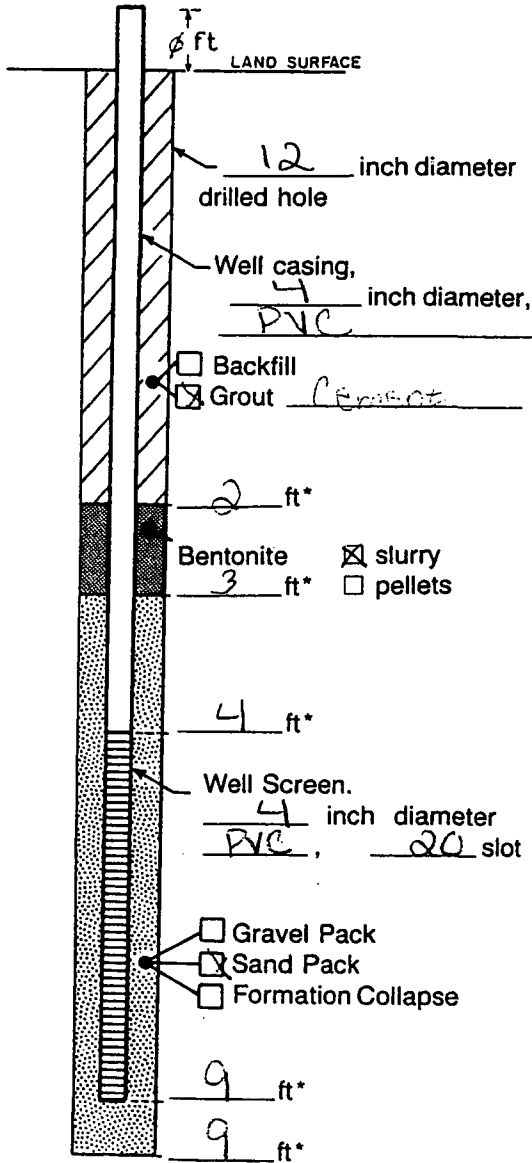

Measuring Point is
Top of Well Casing
Unless Otherwise Noted.

*Depth Below Land Surface

Project Nepera, Inc. Well NW-53S
 Town/City Hammans
 County Crane State NY
 Permit No. _____
 Land-Surface Elevation _____ feet Surveyed
 and Datum _____ feet Estimated
 Installation Date(s) 11/3/99
 Drilling Method Hollow Stem Auger
 Drilling Contractor CTE
 Drilling Fluid NA

Development Technique(s) and Date(s)
Pump and Surge 11/3/99

Fluid Loss During Drilling _____ gallon:
 Water Removed During Development 22 gallon:
 Static Depth to Water 3 feet below M.P.
 Pumping Depth to Water 7 feet below M.P.
 Pumping Duration total of 1 hour
 Yield 0.25 gpm Date 11/3/99
 Specific Capacity _____ gpm/ft
 Well Purpose Monitoring Well

Remarks More than three well volumes
to be pumped during sampling.
Poor recovery.

Prepared by Jennifer Grubb

ARCADIS

Sample/Core Log

Boring/Well MW-53D Project/No. NJ000389.0007.0007 Page 1 of 1

Site Location Harriman, New York Drilling Started 10/29/1999 Drilling Completed 11/2/1999

Total Depth Drilled 58 Feet Hole Diameter 2 inches Type of Sample/
Coring Device Split Spoon

Length and Diameter of Coring Device 2' x 2" Sampling Interval continuous

Land-Surface Elev. _____ feet Surveyed Estimated Datum _____

Drilling Fluid Used NA Drilling Method Direct Push

Drilling Contractor CT&E Driller _____ Helper _____

Prepared By see note Hammer Weight NA Hammer Drop NA ins.

Sample/Core Depth (feet below land surface) Core Recovery (feet) Core Interval (feet)

From	To	Core Recovery (feet)	Core Interval (feet)	Sample/Core Description
3	3.5			SILT; trace Gravel, light brown
4	6			Silty Fine SAND, light brown
6	8			SILT; trace Sand, light brown
8	10			Silty CLAY, greenish grey
10	12			Silty CLAY, greenish grey
12	14			Silty CLAY, greenish grey
14	16			Silty CLAY, greenish grey
16	18			Silty CLAY, greenish grey
18	20			No Sample
20	22			Silty CLAY, greenish grey
22	24			Silty CLAY, greenish grey
24	26			Silty CLAY, greenish grey
26	28			Silty CLAY, greenish grey
28	30			SILT/Very Fine SAND, light brown
30	32			Silty CLAY, greenish grey
32	34			Silty Very Fine SAND, light brown
34	36			Silty Fine SAND, light brown
36	38			Silty Very Fine SAND, light brown
38	40			Silty Very Fine SAND, light brown
40	42			Silty Fine SAND; trace C. Sand/F. Gravel (subangular-subrounded), light brown
42	44			Silty Fine SAND; some C. Sand/F. Gravel (subangular-subrounded), light brown
44	46			Fine SAND; trace Silt, light brown
46	48			Fine SAND with Clay seem
48	50			Fine SAND
50	52			Silty Fine SAND
52	54			Silty Fine SAND
54	56			Silty Fine SAND
56	58			SILT; trace Fine Sand, light brown

Note: Boring log based on sediment samples contained in labelled sample jars found in March 2007 in building 85.

WELL CONSTRUCTION LOG
(UNCONSOLIDATED)

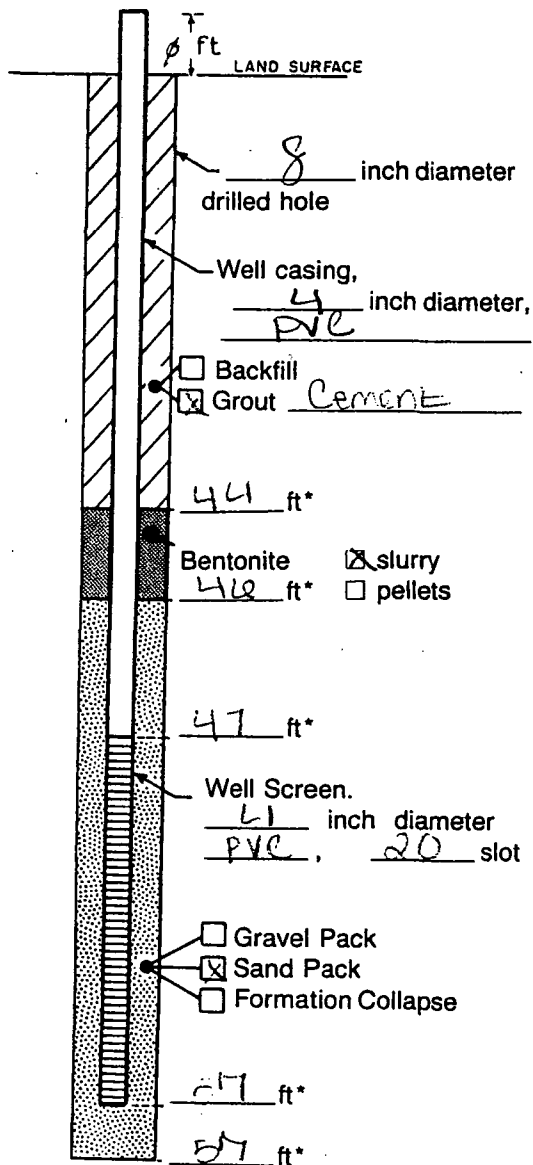

Measuring Point is
Top of Well Casing
Unless Otherwise Noted.

*Depth Below Land Surface

Project Nepera, Inc. Well MW-53D
 Town/City Harriman
 County Orange State NY
 Permit No. _____
 Land-Surface Elevation _____ feet
 Surveyed
 Estimated
 Installation Date(s) 10/29/99 through 11/2/99
 Drilling Method Mud Rotary
 Drilling Contractor CT+E
 Drilling Fluid Mud

Development Technique(s) and Date(s)
Pump and Surge 11/2/99

Fluid Loss During Drilling _____ gallon
 Water Removed During Development 240 gallon
 Static Depth to Water _____ 10 feet below M.F.
 Pumping Depth to Water _____ 10 feet below M.F.
 Pumping Duration _____ 1 hours
 Yield _____ 4 gpm
 Date 11/3/99
 Specific Capacity _____ gpm/ft
 Well Purpose Monitoring Well

Remarks _____

Prepared by Jennifer Guido



MW-28 through MW-34
(MW-32 to be populated.)

MW-28 is near
MW-1, Log for
MW-32 never
completed, can't find
originals 32 impkg lot.
-Charles

**Well Construction Log
(Unconsolidated)**

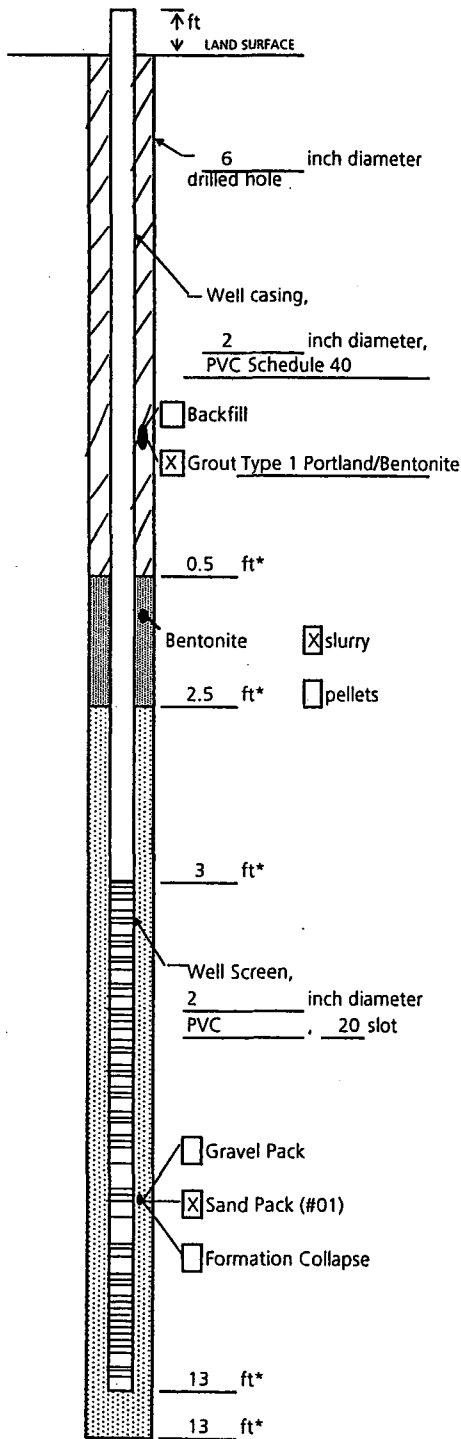

Measuring Point is
Top of Well Casing
Unless Otherwise Noted.

* Depth Below Land Surface

Project NJ000389.0005.00002 Well MW-28S

Town/City Harriman

County Rockland State NY

Permit No. NA

Land-Surface Elevation and Datum:

523.00 feet Surveyed
 Estimated

Installation Date(s) 7/31/00

Drilling Method Hollow Stem Auger

Drilling Contractor Summit, Inc.

Drilling Fluid None

Development Technique(s) and Date(s)

7/31/00, Pump and surge.

Fluid Loss During Drilling N/A gallons

Water Removed During Development 12 gallons

Static Depth to Water Not measured. feet below M.P.

Pumping Depth to Water Not measured. feet below M.P.

Pumping Duration 1 hours

Yield <2.5 gpm Date 7/31/00

Well Purpose Observation well for erosion evaluation.

Remarks Well went dry while developing.

Prepared by J. Guido

ARCADIS GERAGHTY & MILLER
Sample/Core Log

Boring/Well MW-29S Project/No. NJ000389.0005.0002 Page 1 of 1

Site Harriman, New York Drilling Started 0830- 8/8/00 Drilling Completed 1100- 8/8/00

Total Depth Drilled 13 Feet Hole Diameter 6 inches Type of Sample/
 Coring Device Geoprobe

Length and Diameter of Coring Device 4' x 2" Sampling Interval Continuous

Land-Surface Elev. 524.54 feet Surveyed Estimated Datum _____

Drilling Fluid Used None Drilling Method Hollow Stem Auger

Drilling Contractor Summit, Inc. Driller Brandon Reed Helper Russel

Prepared By J. Guido

Sample/Core Depth (feet below land surface)

From	To	Core Recovery (feet)	Sample/Core Description*	PID (ppm)
0	4	4	0-1' Silt; light brown; some Root material.	0
			1-3.5' Silt; light brown.	0
			3.5-4' Silt; grey, wet; some Gravel, fine to medium.	0
4	8	3	0-1' Silt; grey, wet.	0
			1-3' Sand, medium; Gravel, fine to coarse; black, angular and well rounded.	0
8	12	4	0-1' Same as above. Saturated.	0
			1-4' Silt; grey, some layers of brown.	0
12	14	1	0-0.5' Silty Clay; grey.	0
			0.5-1' Silt; grey.	0

**Well Construction Log
(Unconsolidated)**

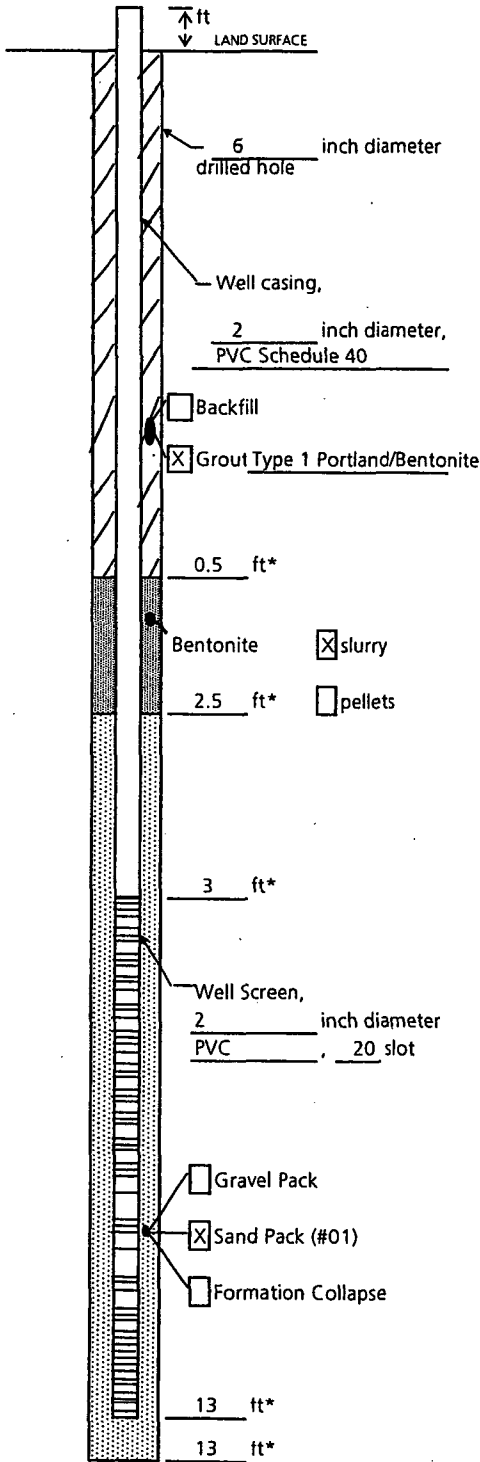

Measuring Point is Top of Well Casing Unless Otherwise Noted.

* Depth Below Land Surface

Project NJ000389.0005.00002 Well MW-295

Town/City Harriman

County Rockland State NY

Permit No. _____

Land-Surface Elevation and Datum:

_____ 524.54 feet Surveyed
 Estimated

Installation Date(s) 8/8/00

Drilling Method Hollow Stem Auger

Drilling Contractor Summit, Inc.

Drilling Fluid None

Development Technique(s) and Date(s)

8/8/00, Pump and surge.

Fluid Loss During Drilling _____ N/A gallons

Water Removed During Development 57.5 gallons

Static Depth to Water Not measured. feet below M.P.

Pumping Depth to Water Not measured. feet below M.P.

Pumping Duration 2.3 hours

Yield 2.5 gpm Date 8/8/2000

Well Purpose Observation well for erosion evaluation.

Remarks _____

Prepared by J. Guido

Sample/Core Log

Boring/Well MW-30S Project/No. NJ000389.0005.0002 Page 1 of 1

Site Harriman, New York Drilling Started 1400-8/29/00 Drilling Completed 1530-8/29/00

Total Depth Drilled 12.5 Feet Hole Diameter 4 inches Type of Sample/
Coring Device Split Spoon Samples.

Length and Diameter of Coring Device 2'x2" Sampling Interval Continuous

Land-Surface Elev. 524.21 feet Surveyed Estimated Datum _____

Drilling Fluid Used None Drilling Method Air Rotary

Drilling Contractor Kendrick Drilling Driller Tom Kendrick Helper Doug

Prepared By J. Guido

Sample/Core Depth (feet below land surface)	Core Recovery (feet)	Time/Hydraulic Pressure or Blows per 6 Inches	Sample/Core Description*	PID (ppm)
--	----------------------------	--	--------------------------	-----------

From	To	Core Recovery (feet)	Time/Hydraulic Pressure or Blows per 6 Inches	Sample/Core Description*	PID (ppm)
0	2	1.8	3-4-5-6	0-1.8' Silty Sand, fine; light brown; some Sand, medium; grey; some root material.	0
2	4	1.5	5-6-7-6	0-0.7' Same as above. 0.7-1.0' Clay, grey.	0
				1.0-1.5' Sand, fine; little Wood; little Clay; dark brown to grey, wet.	0
4	6	1.5	3-4-5-9	0-1.0' Sand, fine; some Gravel, medium; little wood; grey, saturated. 1-1.3' Sand, medium; some Gravel, medium to fine; grey. 1.3-1.5' Sand, medium; some Gravel, coarse to fine; little Clay; grey.	0
6	8	0.5	16-13-6-4	0-0.5' Sand, medium to fine; grey.	0
8	10	2	7-9-7-9	0-0.5' Same as above. 0.5-0.7' Silty Sand, fine; grey. 0.7-1' Sand, medium to coarse; some Silt; grey. 1-2' Silty Clay; grey.	0
10	12	1	10-9-10-6	0-1' Silty Clay, grey; intermittent 4" Sand, fine layers.	0

**Well Construction Log
(Unconsolidated)**

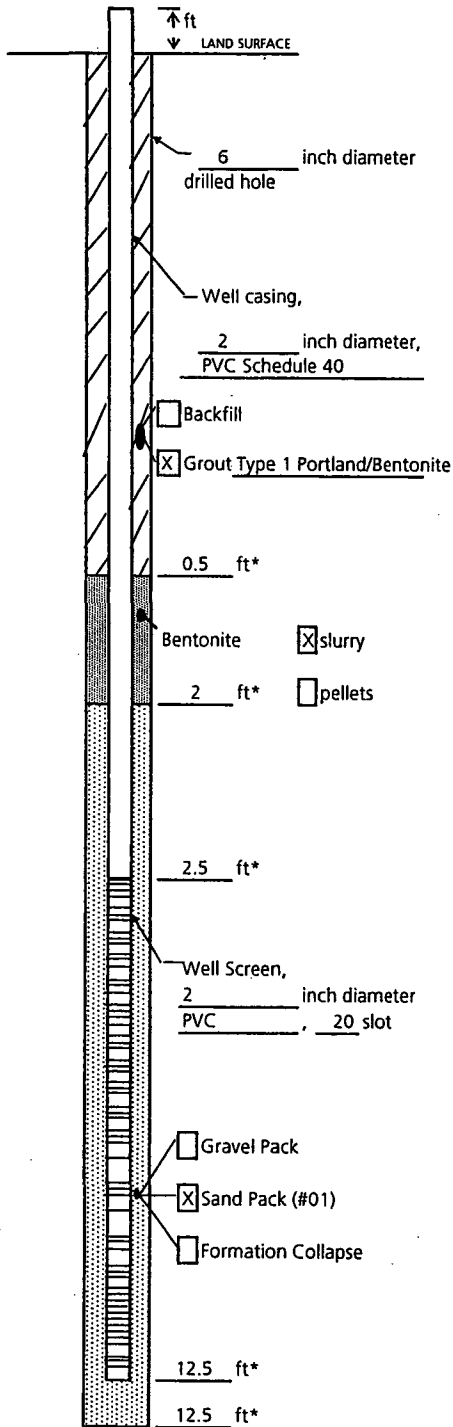

Measuring Point is
Top of Well Casing
Unless Otherwise Noted.

* Depth Below Land Surface

Project NJ000389.0005.00002 Well MW-30S

Town/City Harriman

County Rockland State NY

Permit No. _____

Land-Surface Elevation and Datum:

_____ 524.21 feet Surveyed

Estimated

Installation Date(s) 8/29/00

Drilling Method Air Rotary

Drilling Contractor Kendrick Drilling

Drilling Fluid None

Development Technique(s) and Date(s)

9/1/00, Pump and surge.

Fluid Loss During Drilling _____ N/A gallons

Water Removed During Development 90 gallons

Static Depth to Water 5.96 feet below M.P.

Pumping Depth to Water 7.7 feet below M.P.

Pumping Duration 1 hours

Yield 2 gpm Date 9/1/2000

Well Purpose Observation well for erosion evaluation.

Remarks _____

Prepared by J. Guido

Sample/Core Log

Boring/Well MW-31S Project/No. Nepera, Inc/ NJ000389.0005.0002 Page 1 of 1

Site Harriman, New York Drilling Started 8/29/00; 1100 Drilling Completed 8/29/00; 1230

Total Depth Drilled 12.5 Feet Hole Diameter 4 inches Type of Sample/
Coring Device Split Spoon Samples

Length and Diameter of Coring Device 2' x 2" Sampling Interval Continuous

Land-Surface Elev. 522.13 feet Surveyed Estimated Datum _____

Drilling Fluid Used None Drilling Method Air Rotary

Drilling Contractor Kendrick Drilling Driller Tommy Kendrick Helper Doug

Prepared By J. Guido

Sample/Core Depth (feet below land surface)	Core Recovery (feet)	Time/Hydraulic Pressure or Blows per 6 Inches	Sample/Core Description*	PID (ppm)
---	----------------------	---	--------------------------	-----------

0	2	0.5	1-2-3-4	0-0.5' Silty Clay; some Sand, fine; little root material; brown.	0
2	4	0.5	4-6-16-24	0-0.5' Sand, medium to fine; some Gravel, coarse to medium; grey and brown.	0
4	6	0.5	16-16-16-11	0-0.3' Sand, medium to fine; some Gravel, coarse to medium; little root material; little Silt; grey, brown and tan; 1" Silty Sand spot; red.	0
				0.3-0.5' Gravel, medium to fine; Sand, medium to coarse; grey, wet at 6'.	0
6	8	0.2	8-9-10-16	0-0.2' Clayey Silt; little Gravel, fine; grey.	0
8	10	1.3	9-10-10-10	0-1.3' Silty Clay, grey; silt fining downwards; trace Gravel, medium; grey.	0
10	12	1.2	8-9-10-10	0-1.2' Same as above.	0

Well Construction Log (Unconsolidated)

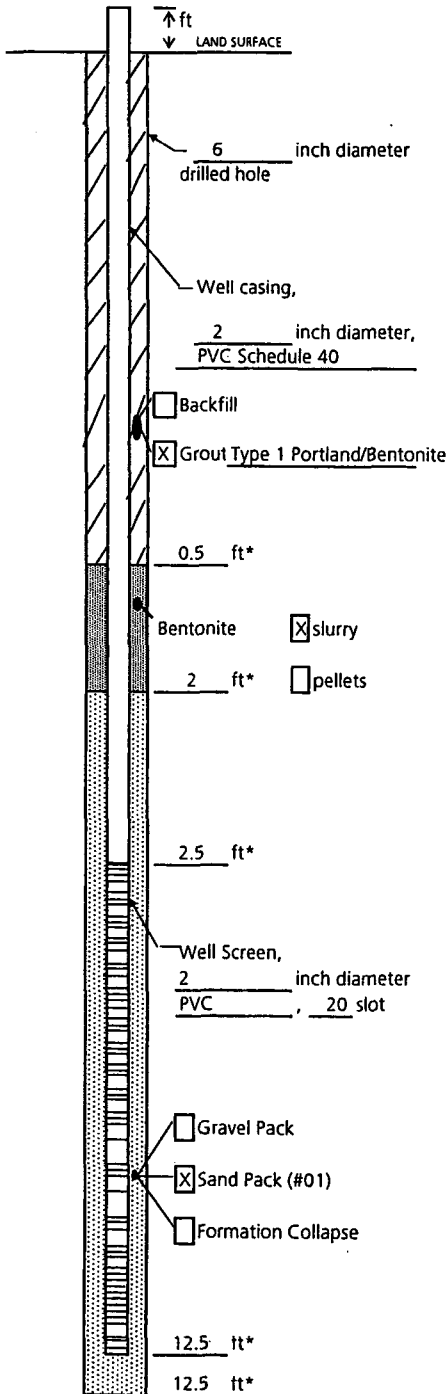

Measuring Point is
Top of Well Casing
Unless Otherwise Noted.

* Depth Below Land Surface

Project NJ000389.0005.00002 Well MW-31S

Town/City Harriman

County Rockland State NY

Permit No. _____

Land-Surface Elevation and Datum:

_____ 522.13 feet Surveyed
 Estimated

Installation Date(s) 8/29/00

Drilling Method Air Rotary

Drilling Contractor Kendrick Drilling

Drilling Fluid None

Development Technique(s) and Date(s)

9/1/00, Pump and surge.

Fluid Loss During Drilling _____ N/A gallons

Water Removed During Development 27 gallons

Static Depth to Water 7.06 feet below M.P.

Pumping Depth to Water 15 feet below M.P.

Pumping Duration 2.5 hours

Yield <0.5 gpm Date 9/1/2000

Well Purpose Observation well for erosion evaluation.

Remarks _____

Prepared by J. Guido

**Well Construction Log
(Unconsolidated)**

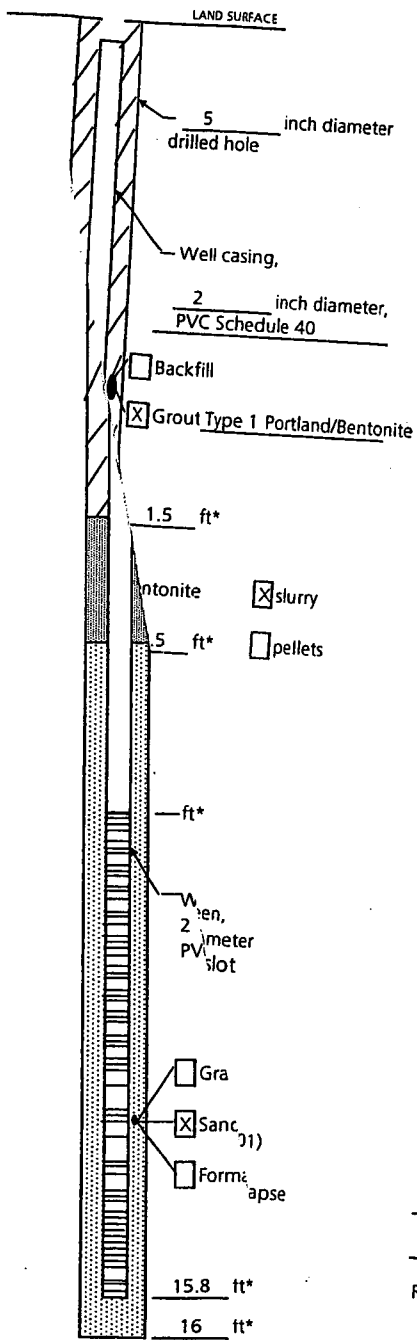

Measuring Point
Top of Well Casing
Unless Otherwise

* Depth Below Land Surface

Project NJ000389.0009.00036 Well MW-32

Town/City Harriman

County Orange State NY

Permit No. _____

Land-Surface/Measuring Point Elevation and Datum:

527.31/526.83 feet Surveyed
 Estimated

Installation Date(s) 6/10/2002

Drilling Method Mud Rotary

Drilling Contractor Kendrick Drilling

Drilling Fluid Bentonite/water

Development Technique(s) and Date(s)

centrifugal pump 6/20/02

Water Removed During Development 30 gallons

Static Depth to Water 7.06 feet below M.P.

Pumping Depth to Water ~10 feet below M.P.

Pumping Duration 1 hours

Yield 0.5 gpm Date 6/20/2002

Well Purpose Monitoring Well

Remarks well installed as flushmount

Prepared by G. Horn

Sample/Core Log

Boring/Well MW-33 Project/No. Nepera, Inc/ NJ000389.0009.00037 Page 1 of 1

Site _____ Drilling _____ Drilling _____
 Location Harriman, New York Started _____ Completed 8/30/2002

Total Depth Drilled 19 Feet Hole Diameter 4 inches Type of Sample/
 Coring Device Mud Rotary/ Split Spoon

Length and Diameter of Coring Device 2 ft. long, 2 in. diameter. Sampling Interval _____

Land-Surface Elev. _____ feet Surveyed Estimated Datum _____

Drilling Fluid Used Bentonite/water Drilling Method Air Rotary

Drilling Contractor Kendrick Drilling Driller Tom Kendrick Helper Don

Prepared By T. Lehman

Sample/Core Depth (feet below land surface)		Core Recovery (feet)	Time/Hydraulic Pressure or Blows per 6 Inches	Sample/Core Description*	PID (ppm)
From	To				
0	2	1	0.0-0.5	Asphalt, rocks.	
			0.5-1.0	Sandy Silt, Medium to Fine; Grey.	
2	4	1.5	0.0-0.5	Silt, Fine; Black, dry.	
			0.5-1.0	Sandy Silt, Fine; Grey, dry.	
			1.0-1.5	Clay; Grey, moist, odors.	
4	6	1	0.0-1.0	Clay; Yello-grey, moist, slight odor.	
6	8	1.5	0.0-0.5	Clay; Yellow-grey, very moist.	
			0.5-1.5	Clay; Yellow-grey, slightly moist.	
8	10	0.7	0.0-0.7	Clay; Grey, slightly moist, no odors.	
10	12	1.5	0.0-0.5	Clay; Dark grey, wet.	
			0.5-1.5	Clay; Yellow-grey, moist.	
12	15	2	0.0-2.0	Sand, Fine to Medium; Rounded, saturated, grey.	

**Well Construction Log
(Unconsolidated)**

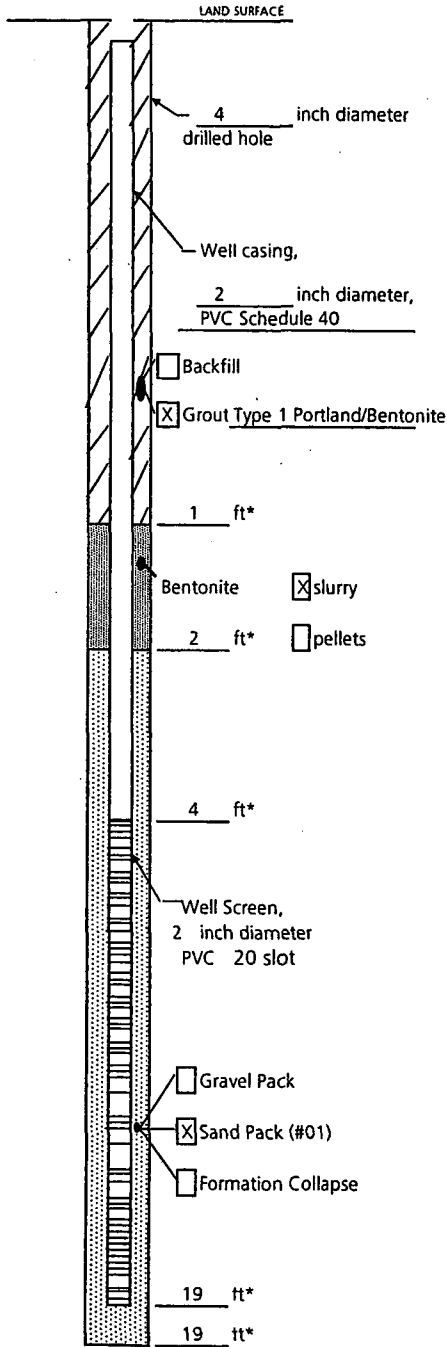

Measuring Point is Top of Well Casing Unless Otherwise Noted.

* Depth Below Land Surface

Project NJ000389.0009.00037 Well MW-33

Town/City Harriman

County Orange State NY

Permit No. _____

Land-Surface/Measuring Point Elevation and Datum:

536.38 feet Surveyed

Estimated

Installation Date(s) 8/30/2002

Drilling Method Mud Rotary

Drilling Contractor Kendrick Drilling

Drilling Fluid Bentonite/water

Development Technique(s) and Date(s)

Submersible Pump 9/5/02

Water Removed During Development 25 gallons

Static Depth to Water 14.16 feet below M.P.

Pumping Depth to Water 18.5 feet below M.P.

Pumping Duration 1 hours

Yield 0.5 gpm Date 9/5/2002

Well Purpose Monitoring Well

Remarks Well installed as flushmount

Measured depth from top of riser - 18.58'

Prepared by G. Horn

Sample/Core Log

Boring/Well MW-34 Project/No. Nepera, Inc/ NJ000389.0009.0037 Page 1 of 1

Site _____ Drilling _____ Drilling _____
 Location Harriman, New York Started _____ Completed 8/30/2002

Total Depth Drilled 19 Feet Hole Diameter 5 inches Type of Sample/
 Coring Device Mud Rotary/ Split Spoon

Length and Diameter of Coring Device 2 ft. long, 2 in. diameter. Sampling Interval _____

Land-Surface Elev. _____ feet Surveyed Estimated Datum _____

Drilling Fluid Used Bentonite/water Drilling Method Air Rotary

Drilling Contractor Kendrick Drilling Driller Tom Kendrick Helper Don

Prepared By T. Lehman

Sample/Core Depth (feet below land surface)	Core Recovery (feet)	Time/Hydraulic Pressure or Blows per 6 Inches	Sample/Core Description*	PID (ppm)
--	----------------------------	--	--------------------------	-----------

0	2	1	0.0-0.5	Asphalt; some Gravel; some Silt; black, dry.	
			0.5-0.75	Clay; Green, dry.	
			0.75-1.0	Clay; Black, dry.	
2	4	1	0.0-0.5	Clay; some Gravel, Medium; Black, dry, and angular.	
			0.5-1.0	Clay; some Gravel, Fine; Black, dry, rounded, odor.	
4	6	0.1	0.0-0.1	Clay; some Gravel, Medium; Black, wet, angular, odor.	
6	8	1	0.0-0.5	Asphalt.	
			0.5-1.0	Clay; Green-grey, saturated, odor.	
				Groundwater encountered at 5.8 ft. bls..	
8	10	1.5	0.0-0.5	Gravel, Medium to Coarse; angular.	
			0.5-1	Clay; Green-grey, moist, odor.	
10	12	0			
13	15	2	0-2	Clay; some Silt; grey, wet, odor.	

**Well Construction Log
(Unconsolidated)**

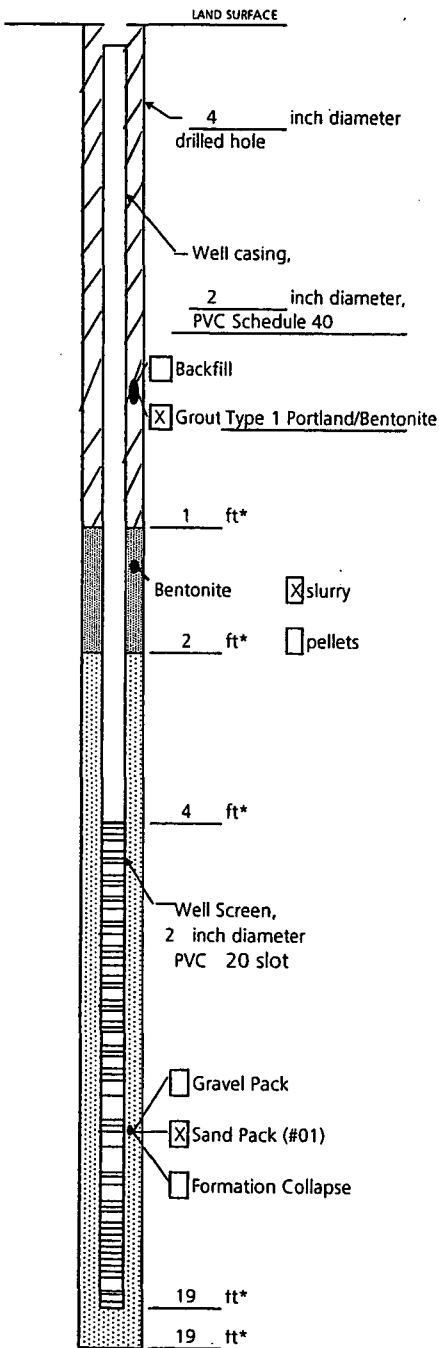

Measuring Point is
Top of Well Casing
Unless Otherwise Noted.

* Depth Below Land Surface

Project NJ000389.0009.00036 Well MW-34

Town/City Harriman

County Orange State NY

Permit No. _____

Land-Surface/Measuring Point Elevation and Datum:

534.48 feet Surveyed

Estimated

Installation Date(s) 8/30/2002

Drilling Method Mud Rotary

Drilling Contractor Kendrick Drilling

Drilling Fluid Bentonite/water

Development Technique(s) and Date(s)

Submersible pump 9/5/02

Water Removed During Development 20 gallons

Static Depth to Water 8.08 feet below M.P.

Pumping Depth to Water 18.25 feet below M.P.

Pumping Duration 1 hours

Yield 0.75 gpm Date 9/5/2002

Well Purpose Monitoring Well

Remarks Well installed as flushmount.

Measured depth from top of riser - 18.58'.

Prepared by G. Horn



}

ARCADIS G&M
Sample/Core Log

near mw-1

Boring/Well B-1 Project/No. NJ000389.0009.00039 Page 1 of 1

Site Harriman Site Drilling Started 11/19/2003 Drilling Completed 11/19/2003

Total Depth Drilled 25 Feet Hole Diameter 4" inches Type of Sample/
 Coring Device Split Spoon

Length and Diameter of Coring Device 4" X 2' Sampling Interval cont. feet

Land-Surface Elev. _____ feet Surveyed Estimated Datum _____

Drilling Fluid Used _____ Drilling Method Mud Rotary

Drilling Contractor Kendrick Enterprises LLC Driller Tom Helper Danny

Prepared By E. Wright Hammer Weight 300 lbs. Hammer Drop 30 ins.

Sample/Core Depth (feet below land surface)	Core Recovery (feet)	Time/Hydraulic Pressure or Blows per 6 Inches	Sample/Core Description
0	2	1.4	2-2-4-2
			0-0.2' Topsoil, organics, black.
			0.2-1.4' CLAY; little Silt; Varves present, grey to brown.
2	4	1.6	4-5-5-8
			0-0.3' CLAY; little Silt; Grey to brown.
			0.3-1.6' SILT; some Clay; grey to brown.
4	6	1.4	6-5-6-5
			SILTY CLAY; Compact, medium moisture, grey to brown.
6	8	2.0	3-4-3-4
			CLAY; little Silt; Saturated, grey.
8	10	1.5	3-3-3-4
			CLAY; little Silt; Finely stratified, saturated, grey.
10	12	2.0	1-2-2-1
			0-1.0' CLAY; little Silt; Saturated, grey.
			1.0-1.5' SILT; Saturated, grey.
			1.5-2.0' CLAY; little Silt; Saturated, grey.
12	14	1.7	8-10-5-7
			0-1.5' SILT; Homogenous, saturated, grey.
			1.5-1.7' SAND, Fine; some Silt; Saturated, grey.
14	16	1.4	18-37-15-12
			GRAVELY SAND, Fine to Medium; Angular to Sub-angular, saturated, grey.
16	17		
			Boulder/Cobble.
17	19	1.1	12-7-8-8
			SAND, Fine to Medium; and Gravel, Fine to Medium; Angular, saturated, grey.
19	21	0.8	10-31-24-24
			SANDY GRAVEL, Fine to Coarse; Angular, saturated, grey.
21	23	0.8	18-24-18-20
			SANDY GRAVEL; Same as above.
23	25	0.5	36-30-20-19
			0-0.3' Same as above.
			0.3-0.5' SILTY SAND, Fine to Medium; little Gravel, Fine; Saturated, grey.

ARCADIS G&M
Sample/Core Log

MW-35

Boring/Well B-2 Project/No. NJ000389.0009.00039 Page 1 of 2

Site _____ Drilling _____ Drilling _____
 Location Harriman Site Started 11/19/2003 Completed 11/20/2003

Total Depth Drilled 35 Feet Hole Diameter 4" inches Type of Sample/
 Coring Device Split Spoon

Length and Diameter of Coring Device 4" X 2' Sampling Interval cont. feet

Land-Surface Elev. _____ feet Surveyed Estimated Datum _____

Drilling Fluid Used _____ Drilling Method Mud Rotary

Drilling Contractor Kendrick Enterprises LLC Driller Tom Helper Danny

Prepared By E. Wright Hammer Weight 300 lbs. Hammer Drop 30 ins.

Sample/Core Depth (feet below land surface)	Core Recovery (feet)	Time/Hydraulic Pressure or Blows per 6 Inches	Sample/Core Description
0	2	0.9	15-5-3-2

From	To	Core Recovery (feet)	Time/Hydraulic Pressure or Blows per 6 Inches	Sample/Core Description
0	2	0.9	15-5-3-2	0-0.3' Asphalt
				0.3-0.8' GRAVELY SAND, Fine to Coarse; little Silt; Angular, saturated, perched watertable, brown.
				0.8-0.9' CLAY; little Silt; Compact, brown to black. At 0.85'-0.9', Clay layer, white.
2	4	0.3	2-2-2-1	SANDY GRAVEL, Fine to Coarse; little Silt; Angular, saturated, brown.
4	6		2-1-1-0	No Recovery. No B-2, S-3 sample taken.
6	8	1.0	1-1-1-1	CLAY; Saturated, grey- dark grey.
8	10		1-0-1-0	No Recovery. No B-2, S-5 sample taken.
10	12	1.3	5-6-7-6	CLAY; little Silt; Saturated, compact, light grey.
12	14	0.2	7-8-8-8	SILT; some Gravel, Fine to Medium; Angular to Sub-angular, saturated, grey.
14	16	1.5	4-6-5-6	SILT; and Sand, Fine; Grey to green.
16	18	1.7	6-6-6-6	SILT; and Sand, Fine; Grey to green.
18	20	1.5	4-5-4-3	Same as above.
20	22	2.0	4-3-3-2	SILT; and Sand, Fine to Coarse; Gravel, Fine at the tip; Grey to green.
22	24	1.5	8-6-37-33	0-1.0' SILT; and Sand, Fine.
				1.0-1.5' SAND; and Gravel.
24	26	1.0	12-10-11-13	GRAVELY SAND, Fine to Coarse; some Silt.

THE
FOLLOWING
DOCUMENTS
WERE OF
POOR
QUALITY

IMAGE
DATA

A Data Distributors Company

ARCADIS G&M Sample/Core Log

mw-36

Boring/Well B-3 Project/No. NJ000389.0009.00039 Drilling Started 11/19/2003 Drilling Completed 11/19/2003

Site Location Harriman Site Hole Diameter 4" inches Type of Sample/ Coring Device Split Spoon

Total Depth Drilled 34 Feet Sampling Interval cont. feet

Length and Diameter of Coring Device 4" X 2' feet Surveyed Estimated Datum _____

Land-Surface Elev. _____ Drilling Method Mud Rotary

Drilling Fluid Used _____ Driller Tom Helper Danny

Drilling Contractor Kendrick Enterprises LLC Hammer Weight 300 lbs. Hammer Drop 30 ins.

Prepared By E. Wright

From	To	Core Recovery (feet)	Time/Hydraulic Pressure or Blows per 6 Inches	Sample/Core Description
0	2	0.8	13-8-3-2	0-0.3' Asphalt
				0.3-0.8' SILTY CLAY; some Sand, Fine to Medium; little Gravel, Fine; Angular, medium moisture, brown.
2	4	0.6	1/2.0'	SILTY SAND, Fine to Medium; little Clay; little Gravel, Fine to Medium; Angular, high moisture, brown.
4	6		1-0-1-1	No Recovery. No B-3, S-3 sample taken.
6	8	1.0	1-2-1-2	SANDY SILT, Fine to Medium; some Gravel, Fine to Medium; Sub-angular, saturated, brown. Piece of plastic found at the base, black.
8	10	0.9	1-2-7-11	SANDY SILT, Fine to Coarse; some Clay; little Gravel, Fine to Medium; Angular, saturated, brown from 0'-0.8', grey from 0.8'-0.9'.
10	12	1.4	9-10-10-10	SILT; saturated, grey.
12	14	1.5	4-6-5-6	Same as above.
14	16	1.1	3-4-3-3	Same as above.
16	18	1.5	1-2-1-1	Same as above.
				0.2-1.0' SANDY SILT, Fine; Saturated, grey.
18	20	1.0	2-7-3-3	SILT; saturated, grey.
20	22	1.3	5-6-8-9	0-1.0' Same as above.
				1.0-1.3' GRAVELY SAND, Fine to Coarse; Angular, saturated, grey.
22	24	0.5	16-10-9-8	GRAVELY SAND, Fine to Coarse; Rounded to Angular, grey.

ARCADIS G&M Well Logs

ARCADIS G&M
Sample/Core Log

MW-37

Boring/Well B-4 Project/No. NJ000389.0009.00039 Page 1 of 1

Site Harriman Site Drilling Started 11/24/2003 Drilling Completed 11/24/2003

Total Depth Drilled 24 Feet Hole Diameter 4" inches Type of Sample/
 Coring Device Split Spoon

Length and Diameter of Coring Device 4" X 2' Sampling Interval cont. feet

Land-Surface Elev. _____ feet Surveyed Estimated Datum _____

Drilling Fluid Used _____ Drilling Method Mud Rotary

Drilling Contractor Kendrick Enterprises LLC Driller Tom Helper Danny

Prepared By E. Wright Hammer Weight 300 lbs. Hammer Drop 30 ins.

Sample/Core Depth (feet below land surface)	Core Recovery (feet)	Time/Hydraulic Pressure or Blows per 6 Inches	Sample/Core Description
0	2	0.7	42-5-4-3
			0-0.3' Asphalt
			0.3-0.7' SANDY SILT; little Gravel, Fine to Medium; little Clay; Angular, brown.
2	4	0.2	2-2-1-1
			Same as above, high moisture.
4	6	0.4	1-0-0-1
			Same as above, saturated.
6	8	0.3	2-2-3-3
			0-0.2' Same as above. 0.2-0.3' CLAY; little Silt; Saturated, grey.
8	10	1.3	8-8-9-6
			SILTY CLAY; Saturated, slight odor, grey.
10	12	1.4	7-5-12-16
			0-0.9' SILT; little Clay; Grey. 0.9-1.4' SANDY GRAVEL, Fine to Coarse; little Silt; Angular, slight odor, grey-brown.
12	14	0.7	21-20-25-25
			Same as above, slight odor, grey-brown.
14	16	1.2	18-15-17-20
			SANDY GRAVEL, Fine to Coarse; little Silt; Angular, brown.
16	18	1.3	10-11-12-18
			Same as above.
18	20	1.1	17-22-31-40
			GRAVELY SAND, Fine to Coarse; trace Silt; Angular, brown.
20	22	1.0	17-22-28-28
			SANDY SILT, Very Fine to Medium; little Gravel, Fine to Coarse; Angular, grey-brown.
22	24	1.3	21-21-31-21
			SILTY SAND, Very Fine to Coarse; trace Gravel, Fine to Medium; Angular, grey.

Sample/Core Log

Boring/Well OW-6 Project/No. NJ000389.0005.0002 Page 1 of 1

Site Harriman, New York Drilling Started 0930-8/7/00 Drilling Completed 1130-8/7/00

Total Depth Drilled 30 Feet Hole Diameter 6 inches Type of Sample/
Coring Device Geoprobe

Length and Diameter of Coring Device 4' x 2" Sampling Interval Continuous

Land-Surface Elev. feet Surveyed Estimated Datum

Drilling Fluid Used None Drilling Method Hollow Stem Auger

Drilling Contractor Summit, Inc. Driller Jeff Marchesani Helper Russel

Prepared By J. Guido

From	To	Core Recovery (feet)	Sample/Core Description*	PID (ppm)
0	4	3	0-1.5' Fill.	0
			1.5-3' Silt; greenish grey with brown layers; some Root material; little Clay; little Gravel, fine; grey. Moist at 3'.	0
4	8	1	0-1' Clay; green. Saturated at 7'.	0
8	12	3	0-1' Silty Clay; brown, some grey layers.	0
			1-3' Silty Clay; greyish green, some brown layers.	0
12	16	2	0-2' Silty Clay; greyish green; some layers of Silty Sand, fine; grey.	0
16	20	1	0-1' Clay; greyish green; trace Gravel, fine.	0
20	24	0.5	0-0.4' Clay; greyish green; some Gravel, fine.	0
			0.4-0.5' Sand, fine; greenish brown.	0
24	28	0.8'	0-0.8' Sand, fine; greyish green.	0

**Well Construction Log
(Unconsolidated)**

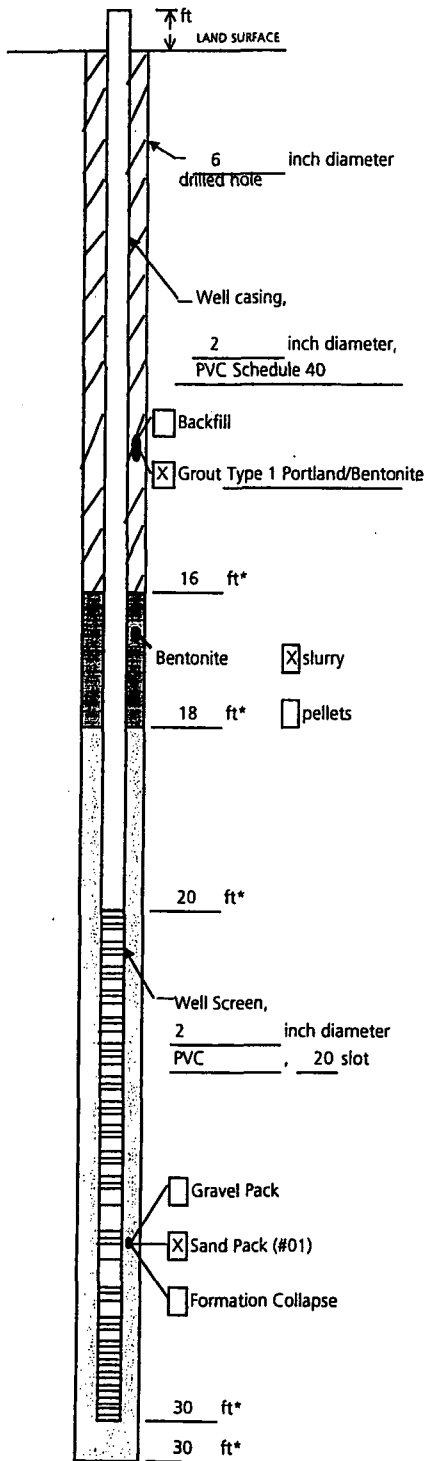

Measuring Point is
Top of Well Casing
Unless Otherwise Noted.

* Depth Below Land Surface

Project NJ000389.0005.00002 Well OW-6

Town/City Harriman

County Rockland State NY

Permit No. NA

Land-Surface Elevation and Datum:

_____ feet Surveyed
 Estimated

Installation Date(s) 8/7/00

Drilling Method Hollow Stem Auger

Drilling Contractor Summit, Inc.

Drilling Fluid None

Development Technique(s) and Date(s)

8/8/00, Pump and surge.

Fluid Loss During Drilling N/A gallons

Water Removed During Development 67.5 gallons

Static Depth to Water Not measured. feet below M.P.

Pumping Depth to Water Not measured. feet below M.P.

Pumping Duration 0.5 hours

Yield 2.5 gpm Date 8/8/00

Well Purpose Observation well for biosparge test.

Remarks _____

Prepared by J. Guido.

Sample/Core Log

Boring/Wel OW-7 Project/No. NJ000389.0005.0002 Page 1 of 1

Site Harriman, New York Drilling Started 1220- 8/7/00 Drilling Completed 1530- 8/7/00

Total Depth Drilled 30 Feet Hole Diameter 6 inches Type of Sample/ Coring Device Geoprobe

Length and Diameter of Coring Device 4' x 2" Sampling Interval Continuous

Land-Surface Elev. feet Surveyed Estimated Datum

Drilling Fluid Used None Drilling Method Hollow Stem Auger

Drilling Contractor Summit, Inc. Driller Jeff Marchesani Helper Russel

Prepared By J. Guido

Sample/Core Depth (feet below land surface) Core Recovery (feet) Sample/Core Description* PID (ppm)

From	To	Core Recovery (feet)	Sample/Core Description*	PID (ppm)
0	4	3	0-1.5' Fill consisting of Sand, medium; Gravel, fine to medium; grey.	0
			1.5-3' Sand, fine to medium; some Silt; some Gravel, medium; greyish green.	0
			Wet at 1.5'	
4	8	4	0-1' Same as above.	0
			1-2' Sand, medium; Gravel, fine to medium; greyish green.	0
			2-4' Silty Clay; greyish green, some grey layers.	0
8	12	3	0-3' Same as above. Saturated at 10'.	0
12	16	3	0-3' Silty Clay; greyish green; some Gravel, fine; black and grey.	0
16	20	0.5	0-0.5' Same as above.	0
20	24	2	0-2' Silty Clay; greyish green, very saturated; some Gravel, fine; black and grey.	0
24	28	3	0-2.5' Silty Sand, fine to medium; greyish green, layers of brown and dark grey.	0
			2.5-3' Silt; brown.	0
28	32	2	0-2' Same as above.	0

**Well Construction Log
(Unconsolidated)**

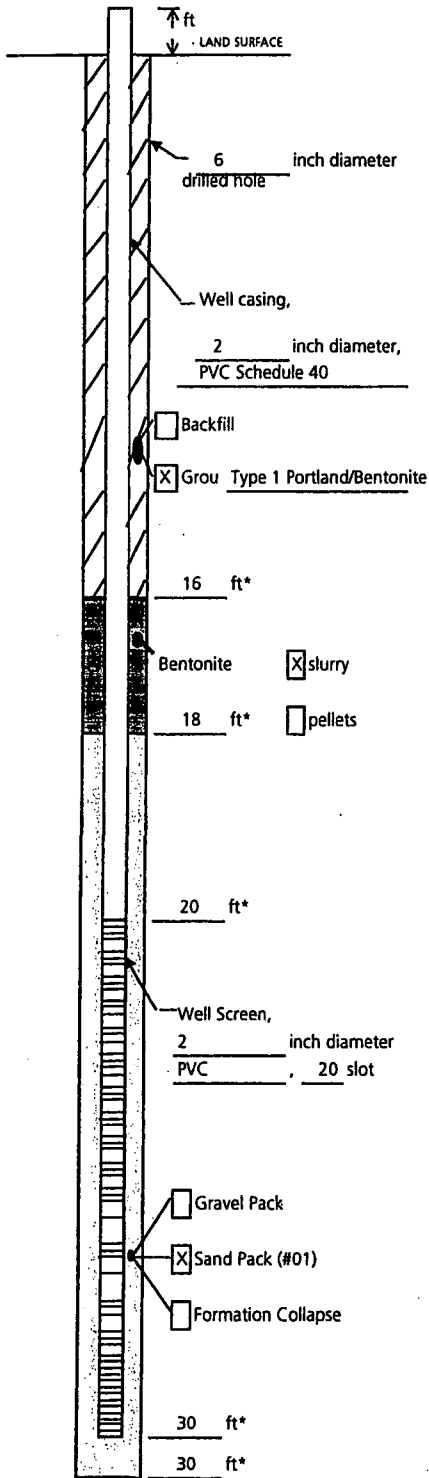

Measuring Point is
Top of Well Casing
Unless Otherwise Noted.

* Depth Below Land Surface

Project NJ000389.0005.00002 Well OW-7

Town/City Harriman

County Rockland State NY

Permit No. NA

Land-Surface Elevation and Datum:

_____ feet Surveyed
 Estimated

Installation Date(s) 8/7/00

Drilling Method Hollow Stem Auger

Drilling Contractor Summit, Inc.

Drilling Fluid None

Development Technique(s) and Date(s)

8/8/00, Pump and surge.

Fluid Loss During Drilling N/A gallons

Water Removed During Development 110 gallons

Static Depth to Water Not measured feet below M.P.

Pumping Depth to Water Not measured feet below M.P.

Pumping Duration 1.5 hours

Yield 2-2.5 gpm Date 8/8/00

Well Purpose Observation well for biosparge test.

Remarks _____

Prepared by J. Guido

Sample/Core Log

Boring/Wel BS-1 Project/No. NJ000389.0005.0002 Page 1 of 1

Site Harriman, New York Drilling Started 1400- 8/7/00 Drilling Completed 1300- 8/8/00

Total Depth Drilled 30 Feet Hole Diameter 6 inches Type of Sample/
Coring Device Geoprobe

Length and Diameter of Coring Device 4' x 2" Sampling Interval Continuous

Land-Surface Elev. feet Surveyed Estimated Datum

Drilling Fluid Used None Drilling Method Hollow Stem Auger

Drilling Contractor Summit, Inc. Driller Jeff Marchesani Helper Russel

Prepared By J. Guido

Sample/Core Depth
(feet below land surface)

From	To	Core Recovery (feet)	Sample/Core Description*	PID (ppm)
0	4	3.5	0-1.5' Fill.	0
			1.5-3.5' Silt; dark grey; some Gravel, fine; some Clay; some Root.	0
4	8	1.5	0-1.5' Clay; greyish green, some grey layers; trace Silt.	0
8	12	2	0-1' Silty Clay; brown; some Gravel, fine.	0
			1-2' Clay; grey; trace Silt.	0
12	16	3	0-3' Silty Clay; trace Sand, fine; grey.	0
16	20	1	0-1' Clay; greyish brown; some Gravel, fine; black; trace Silt; very saturated.	0
20	24	1	0-0.7' Same as above, very saturated.	0
			0.7-1' Sand, fine; some Clay; grey.	0
24	28	0.5	0-0.5' Silty Sand, fine; brown, grey and black.	0
			Could not obtain sample past 28' because hole would cave in.	

**Well Construction Log
(Unconsolidated)**

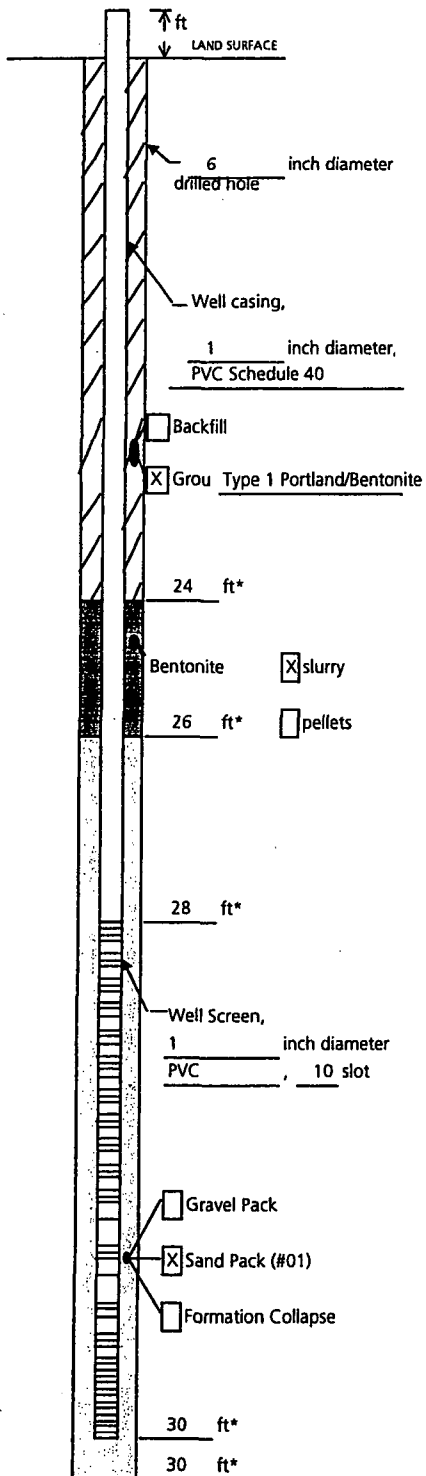

Measuring Point is
Top of Well Casing
Unless Otherwise Noted.

* Depth Below Land Surface

Project NJ000389.0005.00002 Well BS-1

Town/City Harriman

County Rockland State NY

Permit No. NA

Land-Surface Elevation and Datum:

_____ feet Surveyed
 Estimated

Installation Date(s) 8/8/00

Drilling Method Hollow Stem Auger

Drilling Contractor Summit, Inc.

Drilling Fluid None

Development Technique(s) and Date(s)

Well not developed.

Fluid Loss During Drilling N/A gallons

Water Removed During Development -- gallons

Static Depth to Water Not measured. feet below M.P.

Pumping Depth to Water Not measured. feet below M.P.

Pumping Duration -- hours

Yield -- gpm Date --

Well Purpose Injection well for biosparge test.

Remarks _____

Prepared by J. Guido

**Well Construction Log
(Unconsolidated)**

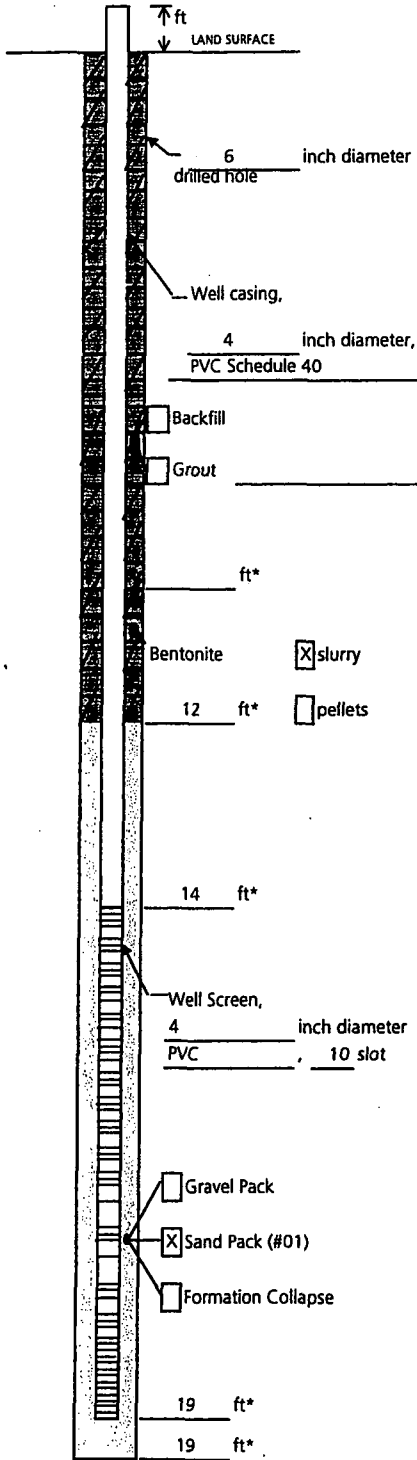

Measuring Point is Top of Well Casing Unless Otherwise Noted.

* Depth Below Land Surface

Project NJ000389.0005.00003 Well VER-1
 Town/City Harriman
 County Rockland State NY
 Permit No. NA

Land-Surface Elevation and Datum:
 _____ feet Surveyed
 Estimated

Installation Date(s) 11/3/00

Drilling Method Hollow Stem Auger

Drilling Contractor Kendrick Drilling

Drilling Fluid None

Development Technique(s) and Date(s)

Well not developed.

Fluid Loss During Drilling NA gallons

Water Removed During Development NA gallons

Static Depth to Water -- feet below M.P.

Pumping Depth to Water -- feet below M.P.

Pumping Duration NA hours

Yield NA gpm Date NA

Well Purpose Injection well for vapor enhancement

recovery.

Remarks _____

Prepared by J. Guido

**Well Construction Log
(Unconsolidated)**

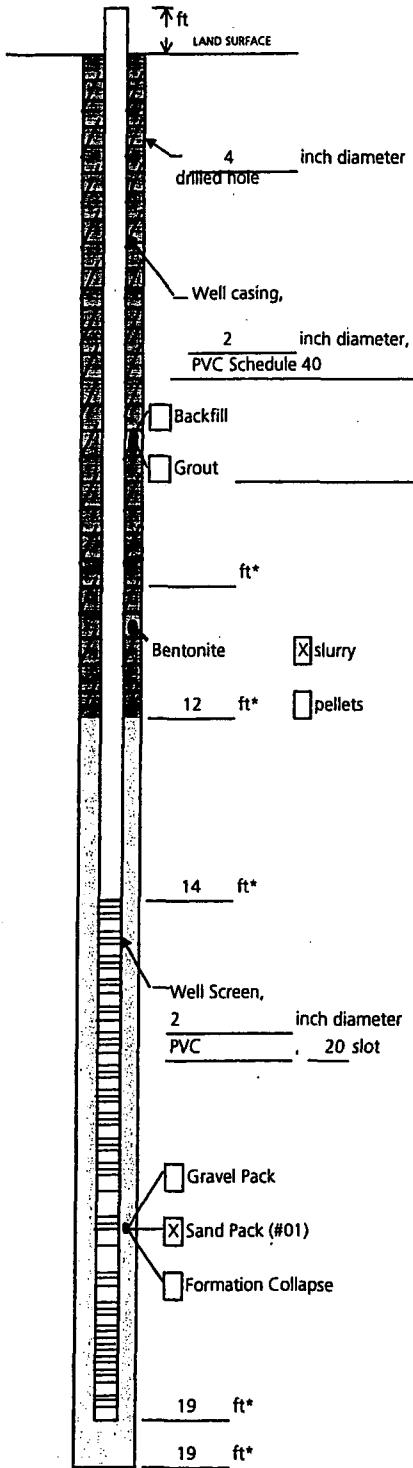

Measuring Point is
Top of Well Casing
Unless Otherwise Noted.

* Depth Below Land Surface

Project NJ000389.0005.00003 Well VER-3 &VER-2

Town/City Harriman

County Rockland State NY

Permit No. NA

Land-Surface Elevation and Datum:

_____ feet Surveyed

Estimated

Installation Date(s) 11/1/00

Drilling Method Drive and Wash

Drilling Contractor Kendrick Drilling

Drilling Fluid None

Development Technique(s) and Date(s)

Well not developed.

Fluid Loss During Drilling NA gallons

Water Removed During Development NA gallons

Static Depth to Water -- feet below M.P.

Pumping Depth to Water -- feet below M.P.

Pumping Duration NA hours

Yield NA gpm Date NA

Well Purpose Observation well for vapor

enhancement recovery.

Remarks _____

Prepared by J. Guido

Sample/Core Log

Boring/Well VER-4 Project/No. NJ000389.0005.0003 Page 1 of 1

Site Harriman, New York Drilling Started 11/1/00-0950 Drilling Completed 11/1/00-1100

Total Depth Drilled 19 Feet Hole Diameter 4 inches Type of Sample/
Coring Device Split Spoon

Length and Diameter of Coring Device 2'x2" Sampling Interval Continuous

Land-Surface Elev. feet Surveyed Estimated Datum

Drilling Fluid Used None Drilling Method Drive and Wash

Drilling Contractor Kendrick Drilling Driller T. Kendrick Helper Doug

Prepared By J. Guido

From	To	Sample/Core Depth (feet below land surface)	Core Recovery (feet)	Time/Hydraulic Pressure or Blows per 6 Inches	Sample/Core Description*	PID (ppm)
0	0.5		drilled		Concrete	
5	7		0.5	2-1-13-15	0-0.5' Silt; little Wood; odor present, black, moist.	16
7	9		1.5	16-16-11-11	0-1' Same as above.	8
					1-1.5' Silt; some Clay; dark olive gray.	
9	11		1.5	9-13-15-12	0-1.5' Clay; and Silt; trace Sand, medium; less than 1mm thick layers; olive gray.	10.8
11	13		1.5	16-13-14-15	0-0.4' Silt; and Clay; dark olive gray.	80-129
					0.4-0.5' Gravel, medium; subangular, gray.	
					0.5-1.5' Silt; and Clay; trace Sand, fine; dark olive gray, and little black specks.	
13	15		1.5	16-20-8-21	0-1.5' Clay; and Silt; trace Sand, fine; dark olive gray, moist, odor present.	80-170
15	17		1.5	11-20-16-13	0-0.4' Clay; and Silt; little Sand, fine to medium; dark olive gray, moist, odor present.	150-801
					0.4-0.6' Gravel, medium to coarse; olive gray.	
					0.6-0.7' Sand, fine to medium; some Silt; some Clay; black.	
					0.7-1.5' Silt; and Clay; trace Sand, fine; dark olive gray; intermittent layers of Sand, fine to medium; black.	
17	19		1.5		0-1.5' Silt; and Clay; dark olive gray.	20-40

**Well Construction Log
(Unconsolidated)**

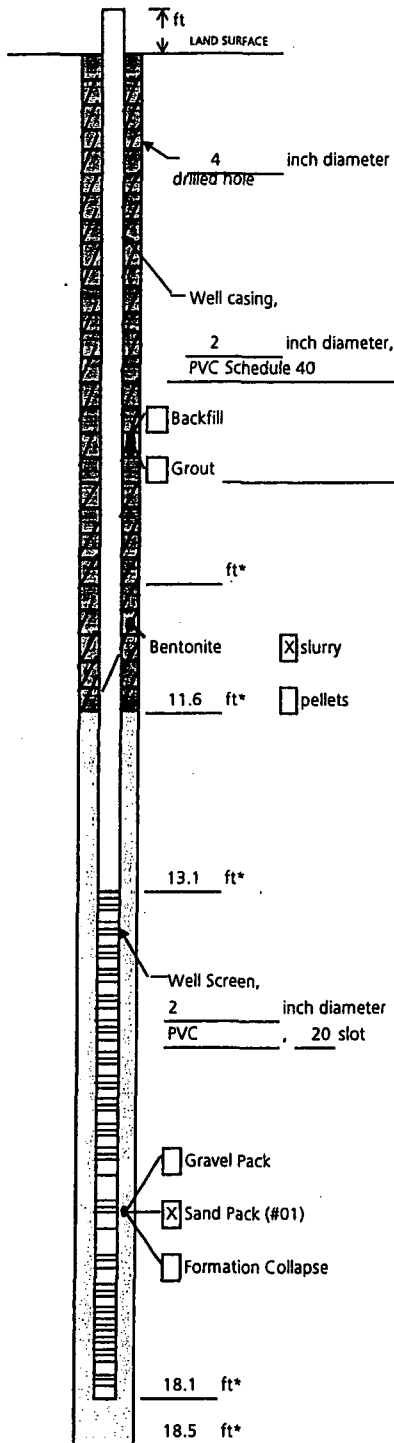

Measuring Point is
Top of Well Casing
Unless Otherwise Noted.

* Depth Below Land Surface

Project NJ000389.0005.00003 Well VER-4
 Town/City Harriman
 County Rockland State NY
 Permit No. NA

Land-Surface Elevation and Datum:

_____ feet Surveyed
 Estimated

Installation Date(s) 11/1/00

Drilling Method Drive and Wash

Drilling Contractor Kendrick Drilling

Drilling Fluid None

Development Technique(s) and Date(s)

Well not developed.

Fluid Loss During Drilling NA gallons

Water Removed During Development NA gallons

Static Depth to Water -- feet below M.P.

Pumping Depth to Water -- feet below M.P.

Pumping Duration NA hours

Yield NA gpm Date NA

Well Purpose Observation well for vapor enhancement
recovery.

Remarks _____

Prepared by J. Guido

**Well Construction Log
(Unconsolidated)**

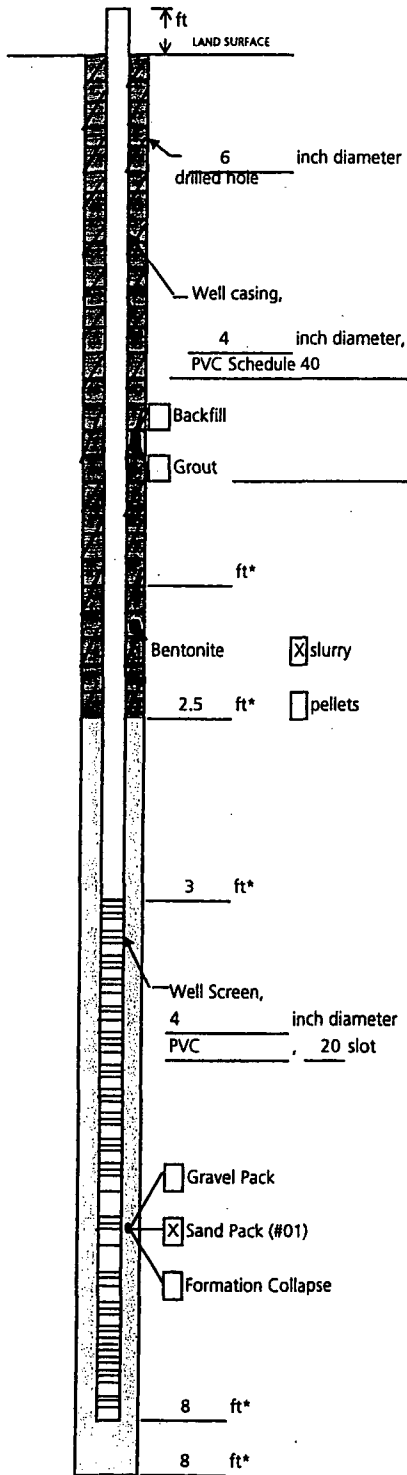

Measuring Point is
Top of Well Casing
Unless Otherwise Noted.

* Depth Below Land Surface

Project NJ000389.0005.00003 Well SVE-1

Town/City Harriman

County Rockland State NY

Permit No. NA

Land-Surface Elevation and Datum:

_____ feet Surveyed
 Estimated

Installation Date(s) 11/2/00

Drilling Method Air Rotary

Drilling Contractor Kendrick Drilling

Drilling Fluid None

Development Technique(s) and Date(s)

Well not developed.

Fluid Loss During Drilling NA gallons

Water Removed During Development NA gallons

Static Depth to Water -- feet below M.P.

Pumping Depth to Water -- feet below M.P.

Pumping Duration NA hours

Yield NA gpm Date NA

Well Purpose Injection well.

Remarks _____

Prepared by J. Guido

Sample/Core Log

Boring/Well SVE-4 Project/No. NJ000389.0005.0003 Page 1 of 1

Site _____ Drilling _____ Drilling _____
 Location Harriman, New York Started 11/2/00-0855 Completed 11/2/00-1100

Total Depth Drilled 9 Feet Hole Diameter 4 inches Type of Sample/
 Coring Device Split Spoon

Length and Diameter of Coring Device 2'x2" Sampling Interval Continuous

Land-Surface Elev. _____ feet Surveyed Estimated Datum _____

Drilling Fluid Used None Drilling Method Drive and Wash

Drilling Contractor Kendrick Drilling Driller T. Kendrick Helper Doug

Prepared By J. Guido

Sample/Core Depth (feet below land surface)	Core Recovery (feet)	Time/Hydraulic Pressure or Blows per 6 Inches	Sample/Core Description*	PID (ppm)	
0	1	drilled	0-0.3' Asphalt.		
			0.3-0.8' Concrete.		
1	3	0.5	11-8-3-3	0-0.5' Fill consisting of Silt; some Gravel, fine to coarse; little Sand, fine; black, strong odor present.	0-80-379
3	5	1.5	3-6-11-20	0-1' Clay; and Silt; little Sand, fine; black and dark olive gray. 1-1.5' Sand, fine to medium; little Gravel, fine; black.	60-100-170
5	7	1.2	3-10-12-16	0-1.2' Sand, very fine; and Silt; black, moist, shiny, very strong odor.	0-180
7	9	1	11-10-12-12	0-1' Silt; and Clay; olive gray, slight odor.	20-33

Well Construction Log (Unconsolidated)

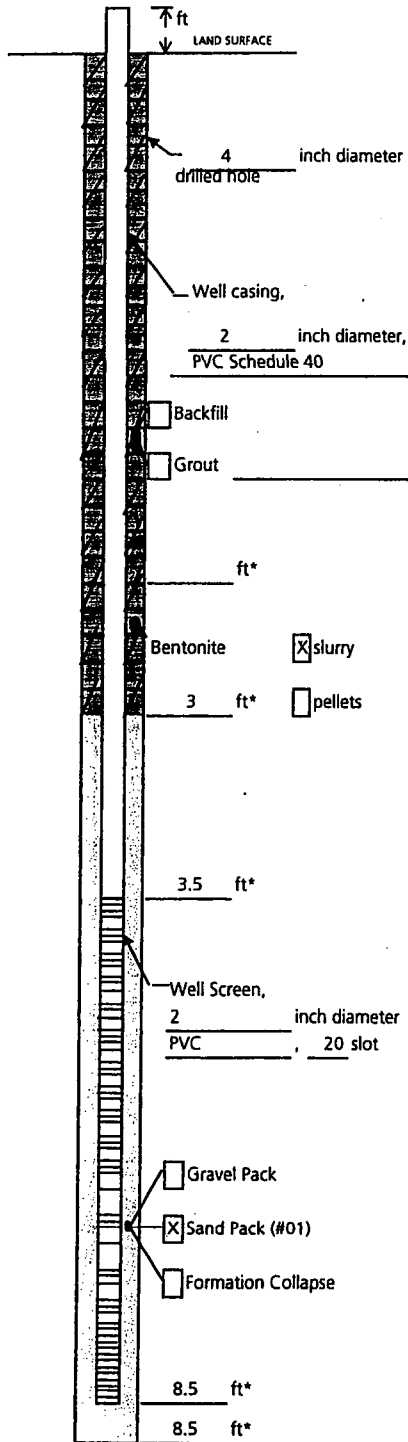

Measuring Point is
Top of Well Casing
Unless Otherwise Noted.

* Depth Below Land Surface

Project NJ000389.0005.00003 Well SVE-2, 3, & 4
 Town/City Harriman
 County Rockland State NY
 Permit No. NA

Land-Surface Elevation and Datum:

_____ feet Surveyed
 Estimated

Installation Date(s) 11/2/00
 Drilling Method Drive and Wash
 Drilling Contractor Kendrick Drilling
 Drilling Fluid None

Development Technique(s) and Date(s)

Wells not developed.

Fluid Loss During Drilling NA gallons
 Water Removed During Development NA gallons
 Static Depth to Water -- feet below M.P.
 Pumping Depth to Water -- feet below M.P.
 Pumping Duration NA hours
 Yield NA gpm Date NA

Well Purpose Observation wells.

Remarks _____

Prepared by J. Guido

Well Construction Log
(Unconsolidated)

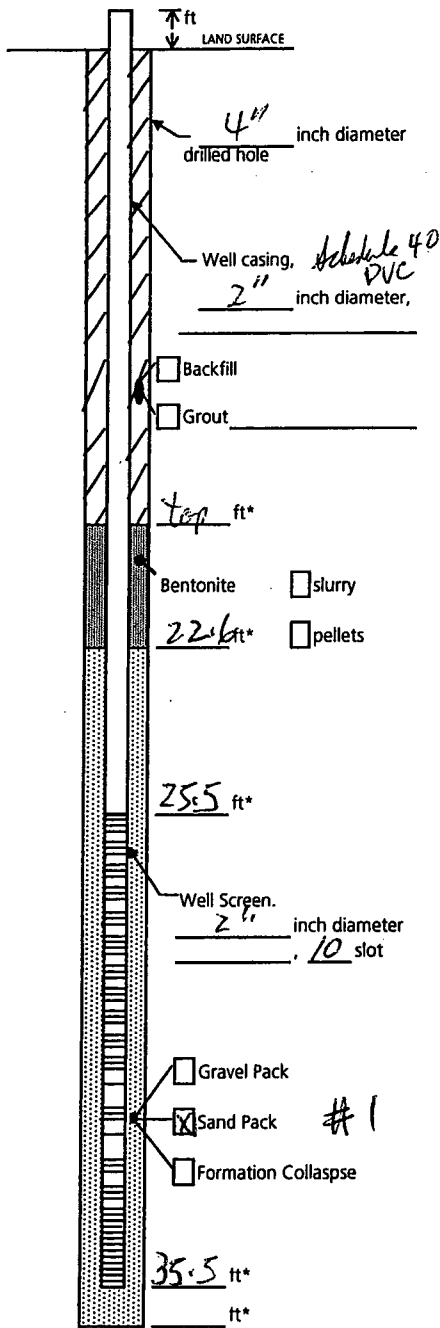

Measuring Point is
Top of Well Casing
Unless Otherwise Noted.

* Depth Below Land Surface

Project HARRIMAN SITE Well MW-355
Town/City HARRIMAN
County ORANGE State NY
Permit No. N/A

Land-Surface Elevation and Datum:
_____ feet Surveyed
_____ feet Estimated

Installation Date(s) 11/20/03
Drilling Method MUD

Drilling Contractor KENDRICK ENT. LTD
Drilling Fluid _____

Development Technique(s) and Date(s)

Fluid Loss During Drilling _____ gallons
Water Removed During Development _____ gallons
Static Depth to Water _____ feet below M.P.
Pumping Depth to Water _____ feet below M.P.
Pumping Duration _____ hours
Yield _____ gpm Date _____
Specific Capacity _____ gpm/ft

Well Purpose _____

Remarks _____

Prepared by _____

Well Construction Log
(Unconsolidated)

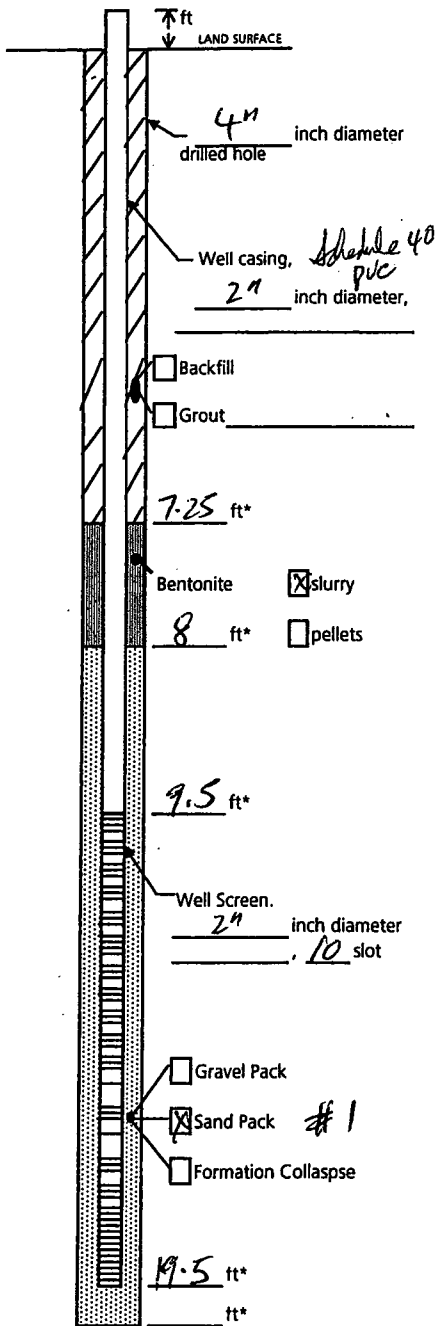

Measuring Point is
Top of Well Casing
Unless Otherwise Noted.

* Depth Below Land Surface

Project HARRIMAN Well MW-35 AQ
Town/City HARRIMAN
County ORANGE State NY
Permit No. _____

Land-Surface Elevation and Datum:
_____ feet Surveyed
_____ feet Estimated

Installation Date(s) 11/20/03
Drilling Method MUD

Drilling Contractor _____
Drilling Fluid _____

Development Technique(s) and Date(s)

Fluid Loss During Drilling _____ gallons

Water Removed During Development _____ gallons

Static Depth to Water _____ feet below M.P.

Pumping Depth to Water _____ feet below M.P.

Pumping Duration _____ hours

Yield _____ gpm Date _____

Specific Capacity _____ gpm/ft

Well Purpose _____

Remarks _____

Prepared by _____

Well Construction Log
(Unconsolidated)

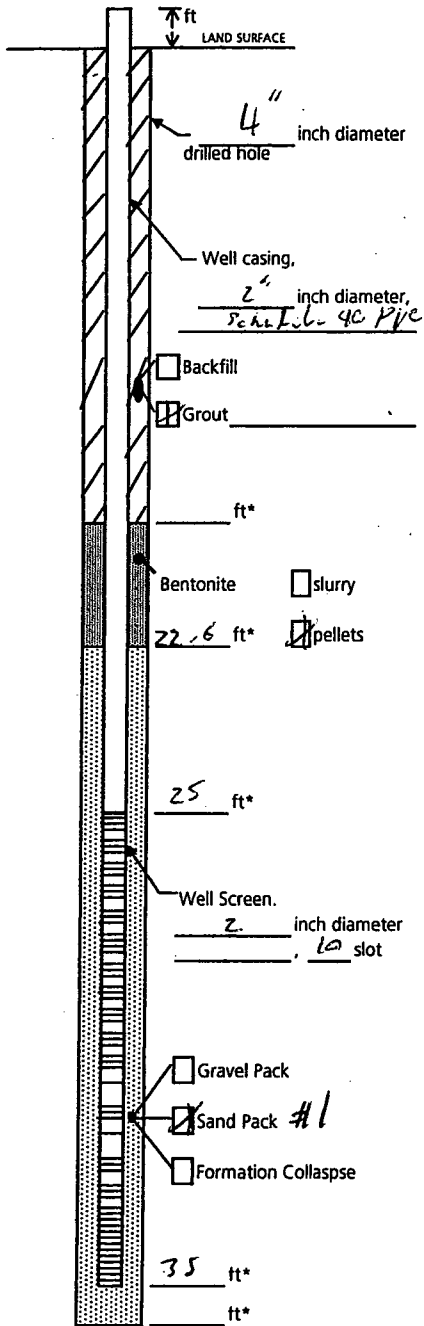

Measuring Point is
Top of Well Casing
Unless Otherwise Noted.

* Depth Below Land Surface

Project Meyers Well MW-365
 Town/City Harrison
 County Orange State NJ
 Permit No. _____

Land-Surface Elevation and Datum:
 _____ feet Surveyed
 _____ feet Estimated

Installation Date(s) 11/21/03
 Drilling Method MWD
 Drilling Contractor Kendrick
 Drilling Fluid _____

Development Technique(s) and Date(s)

Fluid Loss During Drilling _____ gallons
 Water Removed During Development _____ gallons
 Static Depth to Water _____ feet below M.P.
 Pumping Depth to Water _____ feet below M.P.
 Pumping Duration _____ hours
 Yield _____ gpm Date _____
 Specific Capacity _____ gpm/ft

Well Purpose Monitoring

Remarks
2.5 bags Sand #1
1 bag Bentonite

Prepared by EW

Well Construction Log
(Unconsolidated)

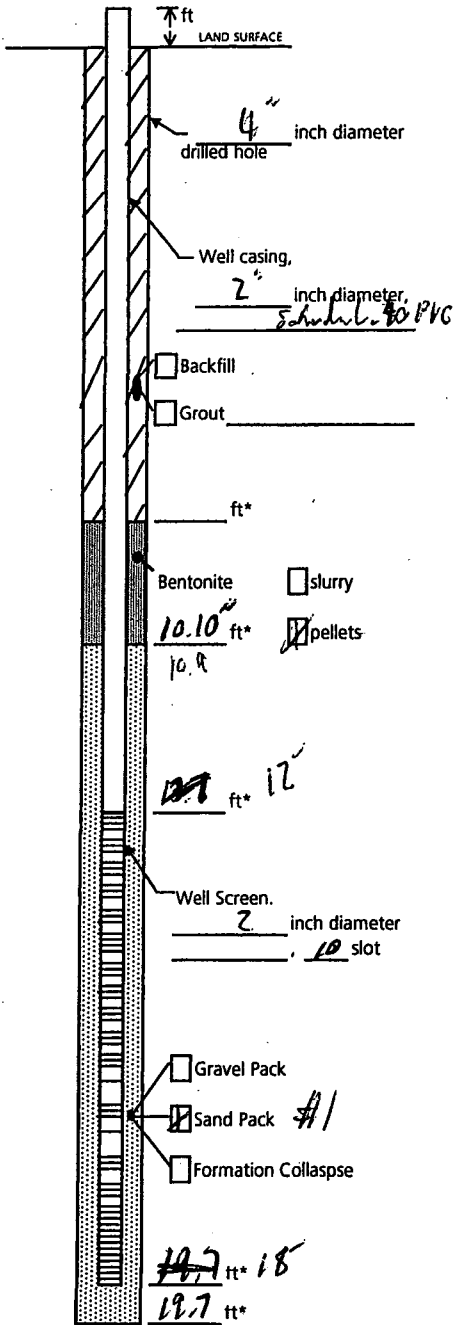

Project Neylan Well MW-36 A Q
 Town/City Harrison
 County Orange State NY
 Permit No. _____

Land-Surface Elevation and Datum:
 _____ feet Surveyed
 Estimated

Installation Date(s) 11/26/07
 Drilling Method Mud
 Drilling Contractor Kendrick
 Drilling Fluid _____

Development Technique(s) and Date(s)

Fluid Loss During Drilling _____ gallons
 Water Removed During Development _____ gallons
 Static Depth to Water _____ feet below M.P.
 Pumping Depth to Water _____ feet below M.P.
 Pumping Duration _____ hours
 Yield _____ gpm Date _____
 Specific Capacity _____ gpm/ft

Well Purpose Monitoring

Remarks 1.75 bags of Sand
bag of Bentonite

Prepared by _____

Well Construction Log
(Unconsolidated)

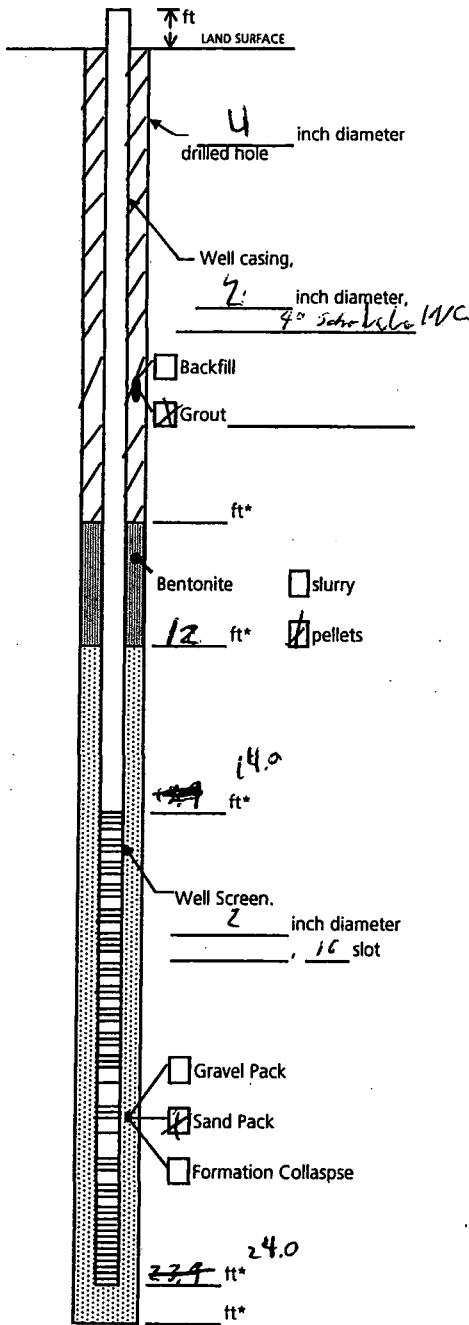

Measuring Point is
Top of Well Casing
Unless Otherwise Noted.

* Depth Below Land Surface

Project Nepera Well MW 375
Town/City Harrison
County Orange State NY
Permit No. _____

Land-Surface Elevation and Datum:
_____ feet Surveyed
_____ feet Estimated

Installation Date(s) 11/24/01
Drilling Method Mud
Drilling Contractor Kentworth
Drilling Fluid _____

Development Technique(s) and Date(s)

Fluid Loss During Drilling _____ gallons
Water Removed During Development _____ gallons
Static Depth to Water _____ feet below M.P.
Pumping Depth to Water _____ feet below M.P.
Pumping Duration _____ hours
Yield _____ gpm Date _____
Specific Capacity _____ gpm/ft

Well Purpose Monitoring

Remarks 2 3/4' below sand
beginning of bentonite

Prepared by _____

Well Construction Log
(Unconsolidated)

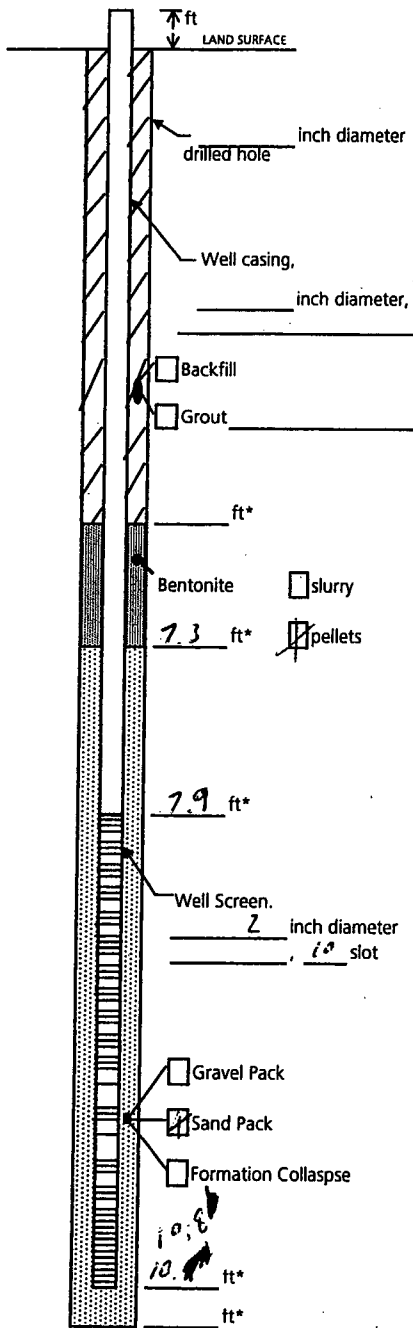

Measuring Point is
Top of Well Casing
Unless Otherwise Noted.

* Depth Below Land Surface

Project Neperu Well MW-37AG
Town/City Harrison
County Orange State NY
Permit No. _____

Land-Surface Elevation and Datum:
_____ feet Surveyed
 Estimated

Installation Date(s) 11/28/03
Drilling Method Mud Rotary
Drilling Contractor Kendrick
Drilling Fluid _____

Development Technique(s) and Date(s)

Fluid Loss During Drilling _____ gallons
Water Removed During Development _____ gallons
Static Depth to Water _____ feet below M.P.
Pumping Depth to Water _____ feet below M.P.
Pumping Duration _____ hours
Yield _____ gpm Date _____
Specific Capacity _____ gpm/ft

Well Purpose Monitoring

Remarks 3/4 bags of Sand #10
1/2 bag of bentonite

Prepared by Ch

Well Construction Log
(Unconsolidated)

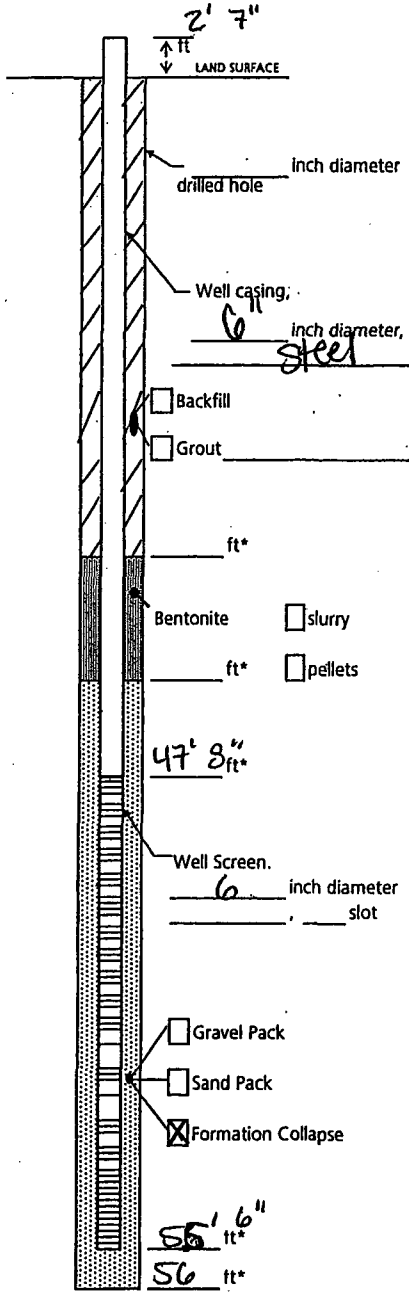

air rotary put in casing then mud

K packer

Johnson wire wrap slot size ?

Measuring Point is Top of Well Casing Unless Otherwise Noted.
* Depth Below Land Surface

Project Trust Well RW-1R
Town/City Harriman
County _____ State NY
Permit No. _____

Land-Surface Elevation and Datum: _____ feet Surveyed Estimated

Installation Date(s) 2/2/05

Drilling Method _____

Drilling Contractor Kendrick Drilling

Drilling Fluid _____

Development Technique(s) and Date(s)

Air 2/3/05

Fluid Loss During Drilling _____ gallons

Water Removed During Development ~800 gallons

Static Depth to Water ~8' feet below M.P.

Pumping Depth to Water NA feet below M.P.

Pumping Duration 2 hours

Yield NA gpm Date _____

Specific Capacity _____ gpm/ft

Well Purpose RECOVERY WELL

Remarks CASING PIPE IS 50' 5"
IT STUCK UP 2' 7" AFTER IT WAS INSTALLED. IF THE CASING FALLS DOWN ANY, THE SCREENED INTERVAL WILL SHRINK.

Prepared by K. Banach / M. Lorenz

USE 1/10 of ft
3/4 horse @ 50 ft

4/20/05
• measured 55.5 bgs to bottom of well
• need to remove pitless adapts.

Well Construction Log
(Unconsolidated)

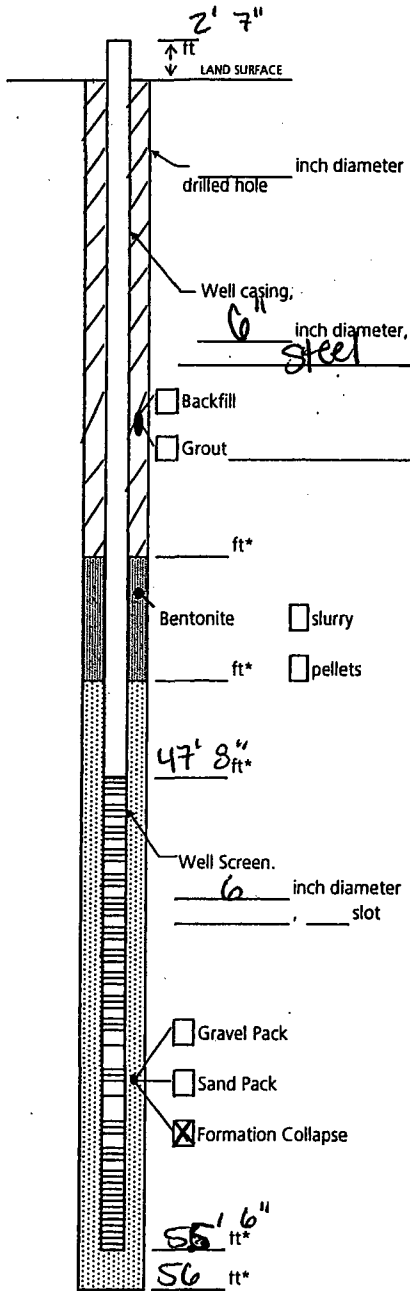

air rotary put in casing
then mud

K packer

Johnson wire wrap slot size ?

Measuring Point is
Top of Well Casing
Unless Otherwise Noted.
* Depth Below Land Surface

Project Trust Well RW-1R
Town/City Harriman
County _____ State NY
Permit No. _____

Land-Surface Elevation and Datum:
_____ feet Surveyed
_____ feet Estimated

Installation Date(s) 2/2/05
Drilling Method _____
Drilling Contractor Kendrick Drilling
Drilling Fluid _____

Development Technique(s) and Date(s)
Air 2/3/05

Fluid Loss During Drilling _____ gallons
Water Removed During Development ~800 gallons
Static Depth to Water ~8' feet below M.P.
Pumping Depth to Water NA feet below M.P.
Pumping Duration 2 hours
Yield NA gpm Date _____
Specific Capacity _____ gpm/ft

Well Purpose RECOVERY WELL

Remarks CASING PIPE IS 50' 5"
IT STUCK UP 2' 7" AFTER IT
WAS INSTALLED. IF THE CASING
FALLS DOWN ANY, THE SCREENED
INTERNAL WILL SHRINK.

Prepared by K. Banach / M. LORENZ

USE 1/10
of ft
3/4 horse
@ 50 ft

Sample/Core Log

Boring/Well BW-1R Project/No. NS 389.9.32 Page 1 of 1

Site Harriman, NY Drilling Started 2/10/05 Drilling Completed _____

Total Depth Drilled _____ Feet Hole Diameter 6" inches Type of Sample/Coring Device _____

Length and Diameter of Coring Device _____ Sampling Interval _____ feet

Land-Surface Elev. _____ feet Surveyed Estimated Datum _____

Drilling Fluid Used _____ Drilling Method _____

Drilling Contractor Ken Drick 845-469-2266 Driller _____ Helper _____

Prepared By K. Banach TOM TERRY Hammer Weight _____ Hammer Drop _____ ins.

Sample/Core Depth (feet below land surface) From _____ To _____ Core Recovery (feet) _____ Time/Hydraulic Pressure or Blows per 6 Inches _____

Water ~ 10'

From	To	Core Recovery (feet)	Time/Hydraulic Pressure or Blows per 6 Inches	Sample/Core Description*
0	37			Silty Sand, Brown w/some
37	47			Clay, Gray, wet
47	50			F-C Sand w/ Gravel, A
50	56			Dark Br, wet same as above, vf



ARCADIS GERAGHTY & MILLER
Sample/Core Log

Boring/Well BS-4 Project/No. NJ000389.00007 Page 1 of 1

Site Location Maybrook Harriman Trust, Harriman, NY Drilling Started 8:15 Drilling Completed 10:00

Total Depth Drilled 30.5 Feet Hole Diameter 4 inches Type of Sample/ Coring Device Roller Bit

Length and Diameter of Coring Device _____ Sampling Interval _____ feet

Land-Surface Elev. _____ feet Surveyed Estimated Datum _____

Drilling Fluid Used EZ-Mud - Bentonite Drilling Method Mud rotary rig

Drilling Contractor Kendrick Drilling Driller Tom Helper Don

Prepared By T. Lehman Hammer Weight _____ Hammer Drop _____ ins.

Sample/Core Depth (feet below land surface) Time/Hydraulic Core Recovery (feet) Pressure or Blows per 6 Inches

From	To	Core Recovery (feet)	Time/Hydraulic Pressure or Blows per 6 Inches	Sample/Core Description*
0	5			Gravel, coarse; brown fill material
5	10			Silty clay, green; silt, light brown
10	16			clay, gray, plastic
16	20			Silty clay, light brown; with sand, v. fine brown to black, rounded
20	23			Cobbles; with gravel medium to coarse; some clay, gray, plastic (harder layer)
23	25			Gravel, medium, angular (taking water)
25	27			Sand, medium to coarse; and gravel fine to medium
27	30.5			Sand, v. fine to fine medium brown; some gravel, fine

Sample/Core Log

Boring/Well BS-8 Project/No. NJ000389.00007 Page 1 of 1

Site Location Maybrook Harriman Trust, Harriman, NY Drilling Started 8:30 Drilling Completed 9:40

Total Depth Drilled 32 Feet Hole Diameter 4 inches Type of Sample/ Coring Device Roller Bit

Length and Diameter of Coring Device _____ Sampling Interval _____ feet

Land-Surface Elev. _____ feet Surveyed Estimated Datum _____

Drilling Fluid Used EZ-Mud - Bentonite Drilling Method Mud rotary rig

Drilling Contractor Kendrick Drilling Driller Tom Helper Don

Prepared By T. Lehman Hammer Weight _____ Hammer Drop _____ ins.

Sample/Core Depth (feet below land surface) From To Core Recovery (feet) Time/Hydraulic Pressure or Blows per 6 Inches

From	To	Core Recovery (feet)	Time/Hydraulic Pressure or Blows per 6 Inches	Sample/Core Description*
0	5			Gravel, coarse; brown fill material
5	8			Gravel, fine, black
8	10			Gravel, medium, black to grey; sand coarse, black to grey
13	22			Silty clay, grey, plastic
22	25			Sand, medium to coarse
25	28			Clay, grey, plastic; sand, coarse; silt, green
28	32			Sand, fine to medium; some silt, grey

Sample/Core Log

Boring/Well BS-11 Project/No. NJ000389.00007 Page 1 of 1

Site Location Maybrook Harriman Trust, Harriman, NY Drilling Started _____ Drilling Completed 11/12/2001

Total Depth Drilled 47.5 Feet Hole Diameter 4 inches Type of Sample/ Coring Device Roller Bit

Length and Diameter of Coring Device _____ Sampling Interval _____ feet

Land-Surface Elev. _____ feet Surveyed Estimated Datum _____

Drilling Fluid Used EZ-Mud - Bentonite Drilling Method Mud rotary rig

Drilling Contractor Kendrick Drilling Driller Tom Helper Don

Prepared By G. Horn Hammer Weight _____ Hammer Drop _____ ins.

Sample/Core Depth (feet below land surface)	Core Recovery (feet)	Time/Hydraulic Pressure or Blows per 6 Inches	Sample/Core Description*
---	----------------------	---	--------------------------

From	To	Core Recovery (feet)	Time/Hydraulic Pressure or Blows per 6 Inches	Sample/Core Description*
0	4			Gravel, coarse (asphalt); silt, black, v.fine, no odor
4	8			Gravel, fine to medium; some silt, black; little sand, fine to medium, brown
8	10			Clay, grey; and silt, black; gravel, fine black; some sand, coarse, black, qtz
10	30			Clay, grey,; silty clay, grey, plastic
30	35			silt, green to grey; silt/clay mix encountered
35	45			silty clay, green to grey mix
45	47			Sand, medium to coarse, round to sub-sound

Sample/Core Log

Boring/Well BS-12 Project/No. NJ000389.00007 Page 1 of 1

Site Location Maybrook Harriman Trust, Harriman, NY Drilling Started 13:31 Drilling Completed 11/13/2001

Total Depth Drilled 47 Feet Hole Diameter 4 inches Type of Sample/ Coring Device Roller Bit

Length and Diameter of Coring Device _____ Sampling Interval _____ feet

Land-Surface Elev. _____ feet Surveyed Estimated Datum _____

Drilling Fluid Used EZ-Mud - Bentonite Drilling Method Mud rotary rig

Drilling Contractor Kendrick Drilling Driller Tom Helper Don

Prepared By G. Horn Hammer Weight _____ Hammer Drop _____ ins.

Sample/Core Depth (feet below land surface)	Core Recovery (feet)	Time/Hydraulic Pressure or Blows per 6 Inches
--	----------------------------	--

From	To	Core Recovery (feet)	Time/Hydraulic Pressure or Blows per 6 Inches	Sample/Core Description*
0	5			Gravel, coarse; brown fill material
5	8			Gravel, coarse; brown fill material
8	10			Silt, grey to green
10	25			Silty clay, gray, plastic
25	30			Gravel, angular to subrounded;; some clay, grey to green
30	38			Clay, grey to green; some gravel, fine to medium
38	47			Gravel, angular to subrounded; some sand, med to coarse; little clay, grey

Sample/Core Log

Boring/Well BS-13 Project/No. NJ000389.00007 Page 1 of 1

Site Maybrook Harriman Trust, Harriman, NY Drilling Started 8:30 Drilling Completed 11:45

Total Depth Drilled 55 Feet Hole Diameter 4 inches Type of Sample/ Coring Device Roller Bit

Length and Diameter of Coring Device _____ Sampling Interval _____ feet

Land-Surface Elev. _____ feet Surveyed Estimated Datum _____

Drilling Fluid Used EZ-Mud - Bentonite Drilling Method Mud rotary rig

Drilling Contractor Kendrick Drilling Driller Tom Helper Don

Prepared By G. Horn Hammer Weight _____ Hammer Drop _____ ins.

Sample/Core Depth (feet below land surface) From To Core Recovery (feet) Time/Hydraulic Pressure or Blows per 6 Inches

From	To	Core Recovery (feet)	Time/Hydraulic Pressure or Blows per 6 Inches	Sample/Core Description*
0	5			Gravel, fine to medium, angular to sub-round; Sand, fine to medium, brown
5	8			Gravel, fine to medium, angular to sub-round; Sand, fine to medium, brown
8	10			Sand, fine, green; some silt, black
10	30			Sand; fine to medium, green; silt, black
30	35			Sand, coarse, black (shale) and opaque white (qtz), sub-angular to rounded; Gravel, fine, black
35	40			Sand, fine to coarse, black; Gravel, fine to medium, black (bore hole collapsing, PID 23.5)
40	45			Sand, v. fine to coarse; some silt green (losing water)
45	50			Sand, fine to medium (odor PID 7.1)
50	53			Competant rock

Sample/Core Log

Boring/Well BS-19 Project/No. NJ000389.00007 Page 1 of 1

Site _____ Drilling _____ Drilling _____
 Location Maybrook Harriman Trust, Harriman, NY Started 8:30 Completed 10:30

Total Depth Drilled 64.5 Feet Hole Diameter 4 inches Type of Sample/
 Coring Device Roller Bit

Length and Diameter of Coring Device _____ Sampling Interval _____ feet

Land-Surface Elev. _____ feet Surveyed Estimated Datum _____

Drilling Fluid Used EZ-Mud - Bentonite Drilling Method Mud rotary rig

Drilling Contractor Kendrick Drilling Driller Tom Helper Don

Prepared By G. Horn Hammer Weight _____ Hammer Drop _____ ins.

Sample/Core Depth (feet below land surface) Core Recovery (feet) Time/Hydraulic Pressure or Blows per 6 Inches

From	To	Core Recovery (feet)	Time/Hydraulic Pressure or Blows per 6 Inches	Sample/Core Description*
0	5			Casing Driver no recovery
5	10			Clay, dark black, organic
10	15			Clay, dark black to grey (grading), little gravel, fine, rounded
15	25			Silty clay, light grey, v. fine
25	30			Silty clay, light grey; some silt, green (chemical odor 7.0 ppm (PID))
30	35			Silt, green to grey; with sand, v. fine, green to black, heavy odor (chem) PID- 23.7ppm
35	42			Silt, green to grey; with sand, v. fine, green to black
42	55			Silt, brown; and V. fine sand, brown
55	60			Silty clay, fine, light to medium grey
60	65			Sand, very coarse, black, subrounded (PID 83.2 ppm)

Well Construction Log

(Unconsolidated)

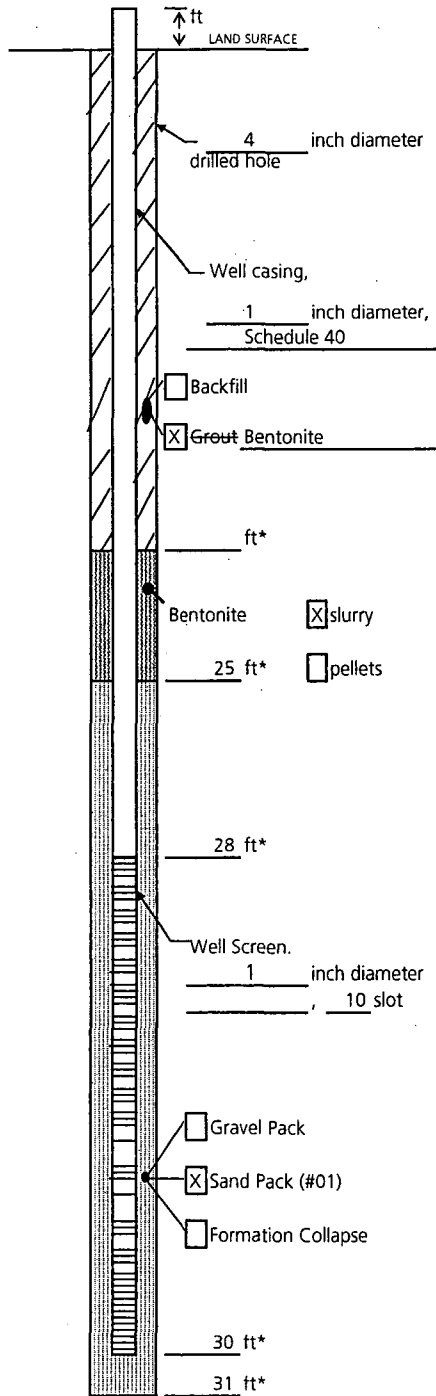

Measuring Point is
Top of Well Casing
Unless Otherwise Noted.

* Depth Below Land Surface

Project NJ000389.0007.00001 Well BS-2

Town/City Harriman

County Orange State NY

Permit No. _____

Land-Surface Elevation and Datum:

_____ feet Surveyed

Estimated

Installation Date(s) 11/15/2001

Drilling Method Mud Rotary

Drilling Contractor Kendrick Drilling

Drilling Fluid EZ Mud

Development Technique(s) and Date(s)

Fluid Loss During Drilling _____ gallons

Water Removed During Development _____ gallons

Static Depth to Water _____ feet below M.P.

Pumping Depth to Water _____ feet below M.P.

Pumping Duration _____ hours

Yield _____ gpm Date _____

Specific Capacity _____ gpm/ft

Well Purpose Expanded Bio Sparge System-

Sparge Well

Remarks _____

Prepared by G. Horn

Well Construction Log

(Unconsolidated)

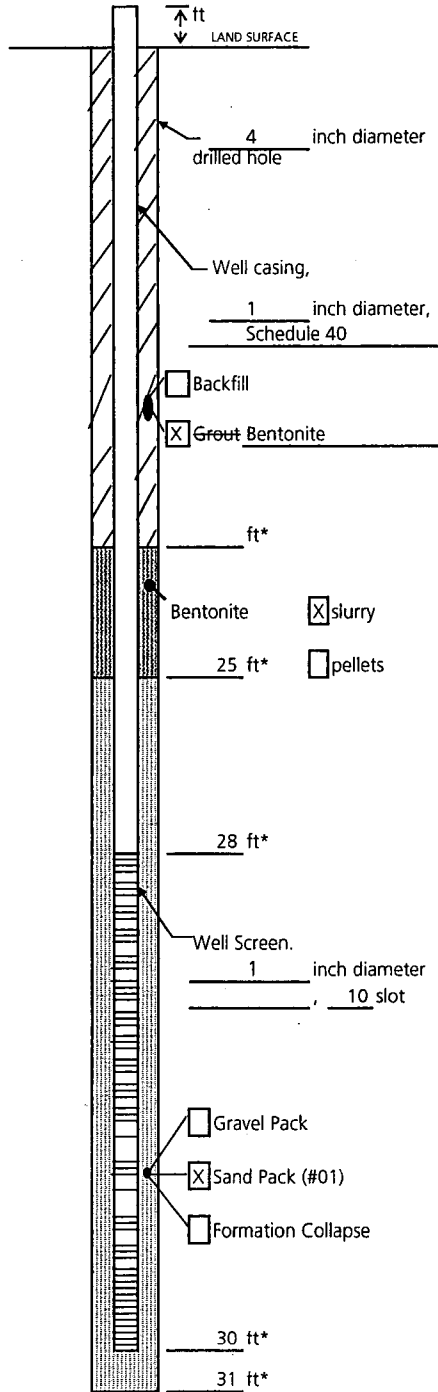

Measuring Point is
Top of Well Casing
Unless Otherwise Noted.

* Depth Below Land Surface

Project NJ000389.0007.00001 Well B5-2

Town/City Harriman

County Orange State NY

Permit No. _____

Land-Surface Elevation and Datum:
_____ feet Surveyed
 Estimated

Installation Date(s) 11/15/2001

Drilling Method Mud Rotary

Drilling Contractor Kendrick Drilling

Drilling Fluid EZ Mud

Development Technique(s) and Date(s)

Fluid Loss During Drilling _____ gallons

Water Removed During Development _____ gallons

Static Depth to Water _____ feet below M.P.

Pumping Depth to Water _____ feet below M.P.

Pumping Duration _____ hours

Yield _____ gpm Date _____

Specific Capacity _____ gpm/ft

Well Purpose Expanded Bio Sparge System-

Sparge Well

Remarks _____

Prepared by G. Horn

Well Construction Log

(Unconsolidated)

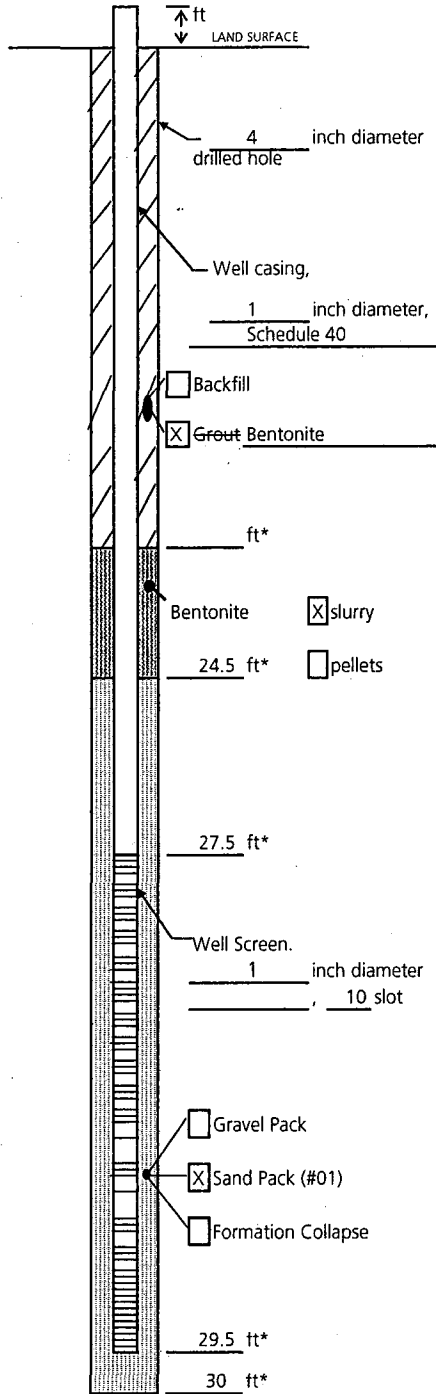

Measuring Point is
Top of Well Casing
Unless Otherwise Noted.

* Depth Below Land Surface

Project NJ000389.0007.00001 Well BS-3

Town/City Harriman

County Orange State NY

Permit No. _____

Land-Surface Elevation and Datum:
_____ feet Surveyed
 Estimated

Installation Date(s) 11/15/2001

Drilling Method Mud Rotary

Drilling Contractor Kendrick Drilling

Drilling Fluid EZ Mud

Development Technique(s) and Date(s)

Fluid Loss During Drilling _____ gallons

Water Removed During Development _____ gallons

Static Depth to Water _____ feet below M.P.

Pumping Depth to Water _____ feet below M.P.

Pumping Duration _____ hours

Yield _____ gpm Date _____

Specific Capacity _____ gpm/ft

Well Purpose Expanded Bio Sparge System-
Sparge Well

Remarks _____

Prepared by G. Horn

Well Construction Log

(Unconsolidated)

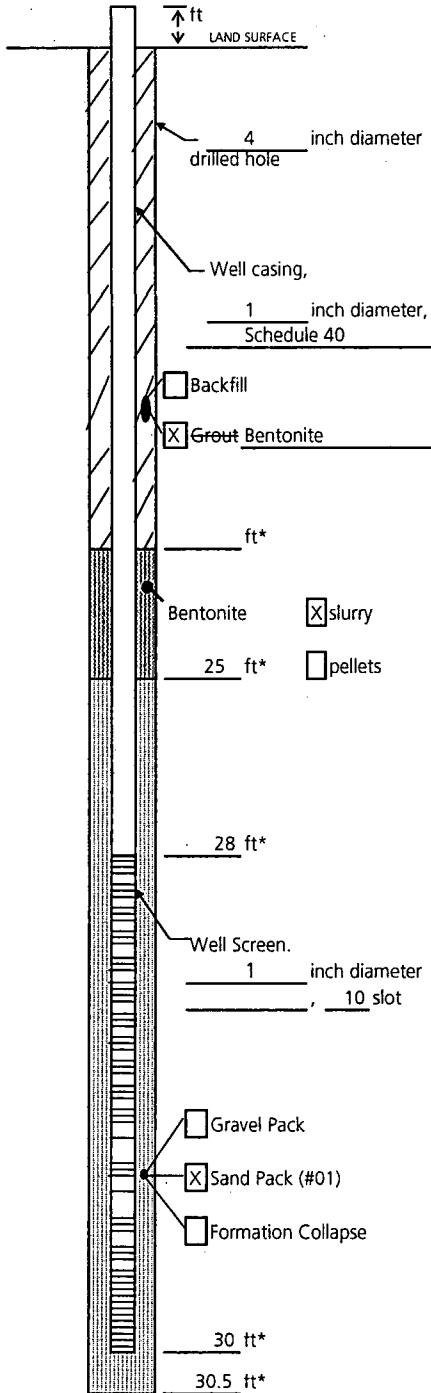

Measuring Point is
Top of Well Casing
Unless Otherwise Noted.

* Depth Below Land Surface

Project NJ000389.0007.00001 Well BS-4

Town/City Harriman

County Orange State NY

Permit No. _____

Land-Surface Elevation and Datum:
_____ feet Surveyed
 Estimated

Installation Date(s) 11/16/2001

Drilling Method Mud Rotary

Drilling Contractor Kendrick Drilling

Drilling Fluid EZ Mud

Development Technique(s) and Date(s)

Fluid Loss During Drilling _____ gallons

Water Removed During Development _____ gallons

Static Depth to Water _____ feet below M.P.

Pumping Depth to Water _____ feet below M.P.

Pumping Duration _____ hours

Yield _____ gpm Date _____

Specific Capacity _____ gpm/ft

Well Purpose Expanded Bio Sparge System-

Sparge Well

Remarks _____

Prepared by G. Horn

Well Construction Log

(Unconsolidated)

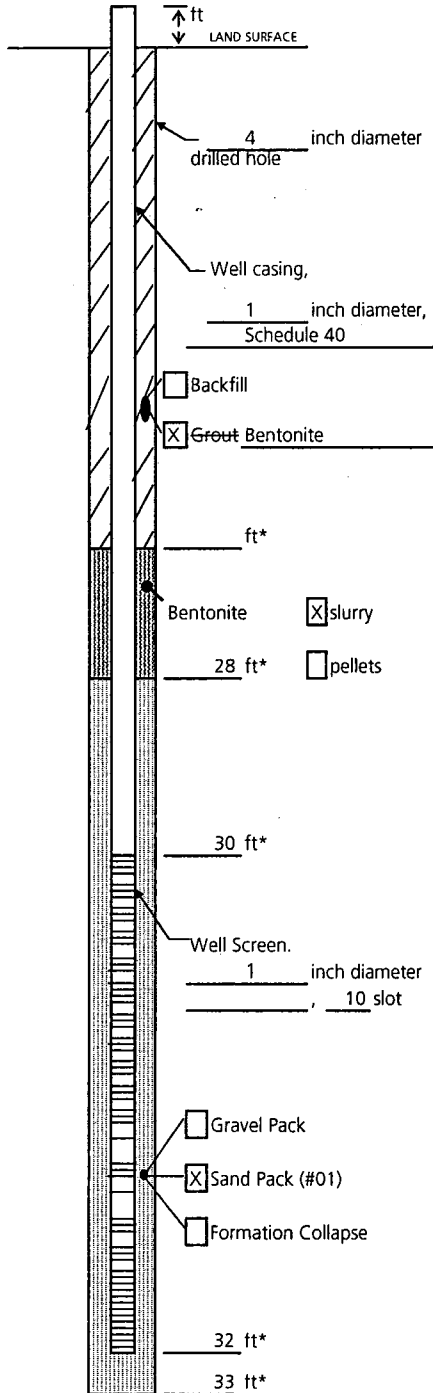

Measuring Point is
Top of Well Casing
Unless Otherwise Noted.

* Depth Below Land Surface

Project NJ000389.0007.00001 Well BS-5

Town/City Harriman

County Orange State NY

Permit No. _____

Land-Surface Elevation and Datum:
_____ feet Surveyed
 Estimated

Installation Date(s) 11/15/2001

Drilling Method Mud Rotary

Drilling Contractor Kendrick Drilling

Drilling Fluid EZ Mud

Development Technique(s) and Date(s)

Fluid Loss During Drilling _____ gallons

Water Removed During Development _____ gallons

Static Depth to Water _____ feet below M.P.

Pumping Depth to Water _____ feet below M.P.

Pumping Duration _____ hours

Yield _____ gpm Date _____

Specific Capacity _____ gpm/ft

Well Purpose Expanded Bio Sparge System-

Sparge Well

Remarks _____

Prepared by G. Horn

Well Construction Log

(Unconsolidated)

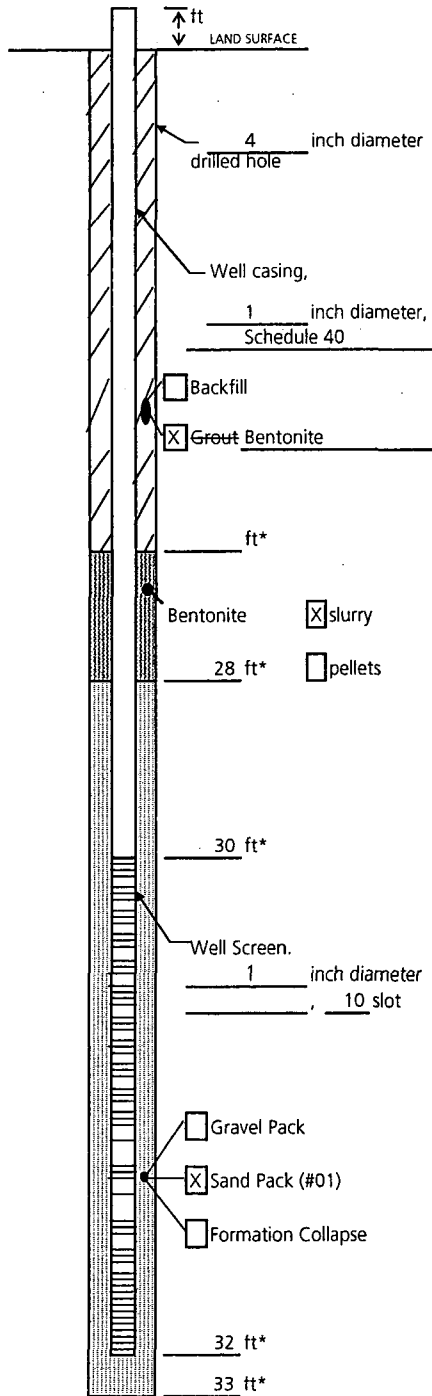

Measuring Point is
Top of Well Casing
Unless Otherwise Noted.

* Depth Below Land Surface

Project NJ000389.0007.00001 Well BS-6

Town/City Harriman

County Orange State NY

Permit No. _____

Land-Surface Elevation and Datum:

_____ feet Surveyed
 Estimated

Installation Date(s) 11/14/2001

Drilling Method Mud Rotary

Drilling Contractor Kendrick Drilling

Drilling Fluid EZ Mud

Development Technique(s) and Date(s)

Fluid Loss During Drilling _____ gallons

Water Removed During Development _____ gallons

Static Depth to Water _____ feet below M.P.

Pumping Depth to Water _____ feet below M.P.

Pumping Duration _____ hours

Yield _____ gpm Date _____

Specific Capacity _____ gpm/ft

Well Purpose Expanded Bio Sparge System-

Sparge Well

Remarks _____

Prepared by G. Horn

Well Construction Log

(Unconsolidated)

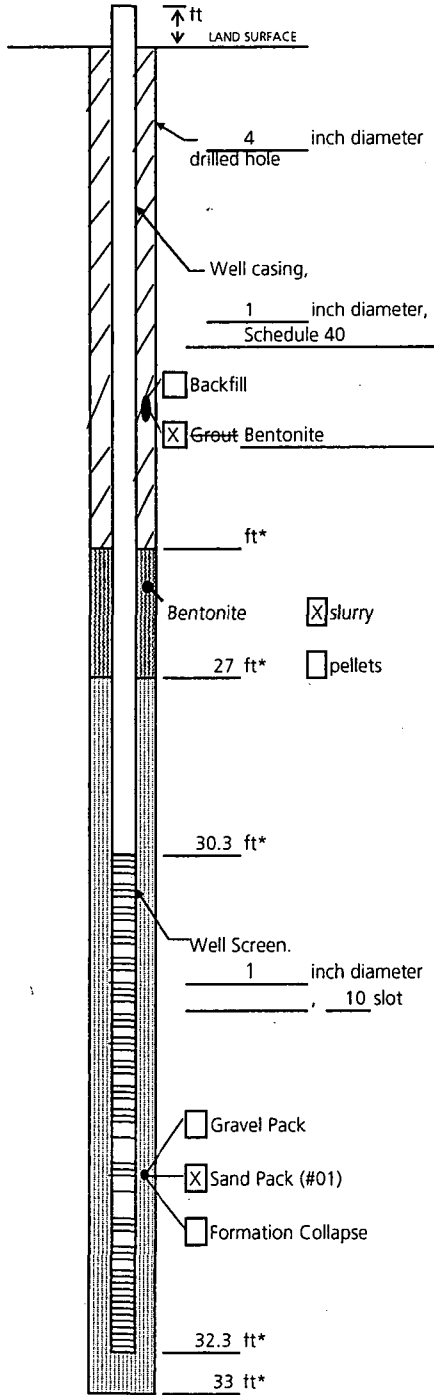

Measuring Point is
Top of Well Casing
Unless Otherwise Noted.

* Depth Below Land Surface

Project NJ000389.0007.00001 Well BS-7

Town/City Harriman

County Orange State NY

Permit No. _____

Land-Surface Elevation and Datum:
_____ feet Surveyed
 Estimated

Installation Date(s) 11/14/2001

Drilling Method Mud Rotary

Drilling Contractor Kendrick Drilling

Drilling Fluid EZ Mud

Development Technique(s) and Date(s)

Fluid Loss During Drilling _____ gallons

Water Removed During Development _____ gallons

Static Depth to Water _____ feet below M.P.

Pumping Depth to Water _____ feet below M.P.

Pumping Duration _____ hours

Yield _____ gpm Date _____

Specific Capacity _____ gpm/ft

Well Purpose Expanded Bio Sparge System-

Sparge Well _____

Remarks _____

Prepared by G. Horn

Well Construction Log

(Unconsolidated)

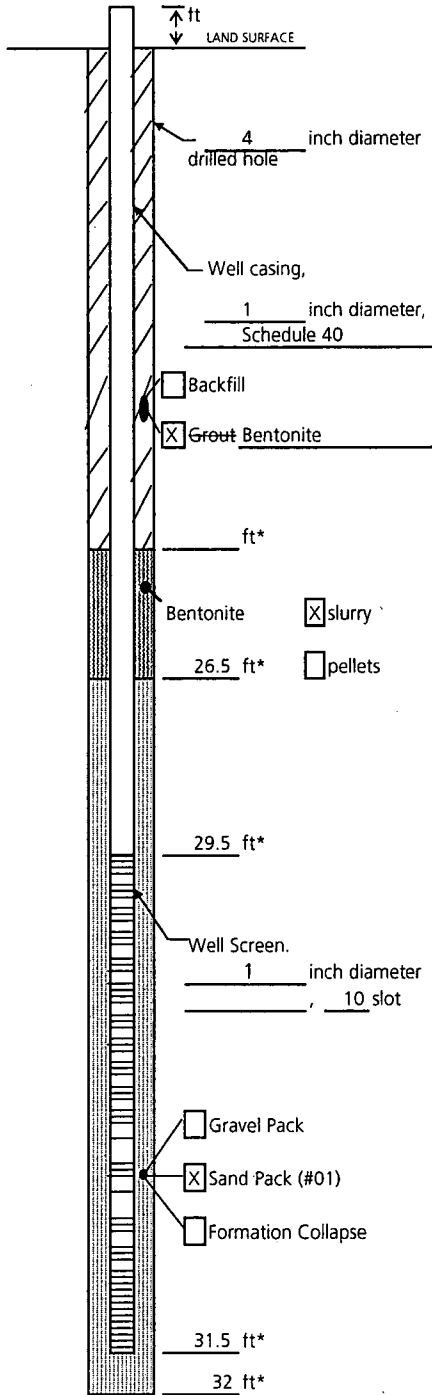

Measuring Point is
Top of Well Casing
Unless Otherwise Noted.

* Depth Below Land Surface

Project NJ000389.0007.00001 Well BS-8

Town/City Harriman

County Orange State NY

Permit No. _____

Land-Surface Elevation and Datum:
_____ feet Surveyed
 Estimated

Installation Date(s) 11/14/2001

Drilling Method Mud Rotary

Drilling Contractor Kendrick Drilling

Drilling Fluid EZ Mud

Development Technique(s) and Date(s)

Fluid Loss During Drilling _____ gallons

Water Removed During Development _____ gallons

Static Depth to Water _____ feet below M.P.

Pumping Depth to Water _____ feet below M.P.

Pumping Duration _____ hours

Yield _____ gpm Date _____

Specific Capacity _____ gpm/ft

Well Purpose Expanded Bio Sparge System-

Sparge Well _____

Remarks _____

Prepared by G. Horn

Well Construction Log

(Unconsolidated)

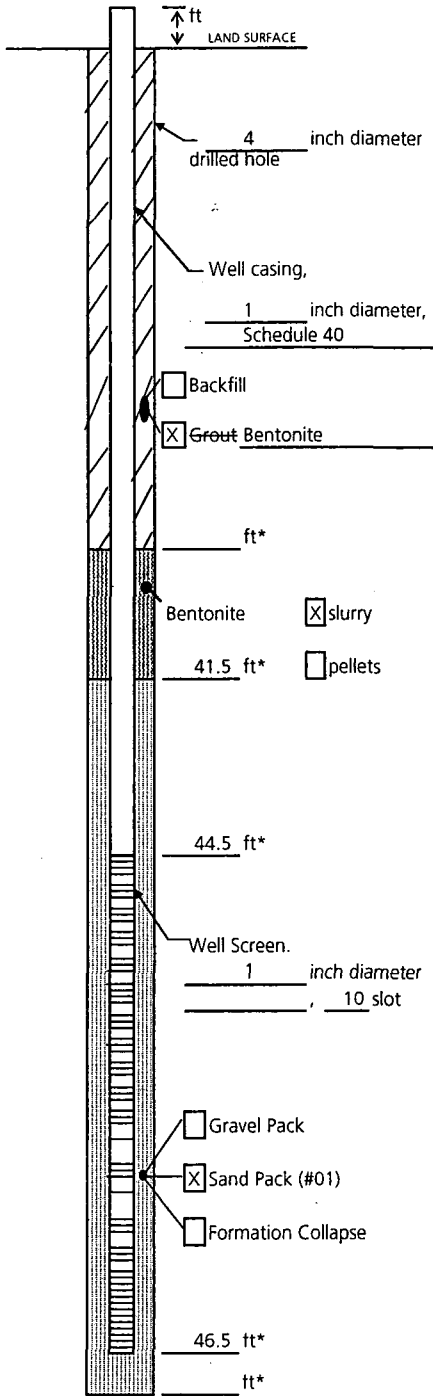

Measuring Point is
Top of Well Casing
Unless Otherwise Noted.

* Depth Below Land Surface

Project NJ000389.0007.00001. Well BS-9

Town/City Harriman

County Orange State NY

Permit No. _____

Land-Surface Elevation and Datum:
_____ feet Surveyed
_____ feet Estimated

Installation Date(s) 11/12/2001

Drilling Method Mud Rotary

Drilling Contractor Kendrick Drilling

Drilling Fluid EZ Mud

Development Technique(s) and Date(s)

Fluid Loss During Drilling _____ gallons

Water Removed During Development _____ gallons

Static Depth to Water _____ feet below M.P.

Pumping Depth to Water _____ feet below M.P.

Pumping Duration _____ hours

Yield _____ gpm Date _____

Specific Capacity _____ gpm/ft

Well Purpose Expanded Bio Sparge System-

Sparge Well _____

Remarks _____

Prepared by G. Horn

Well Construction Log

(Unconsolidated)

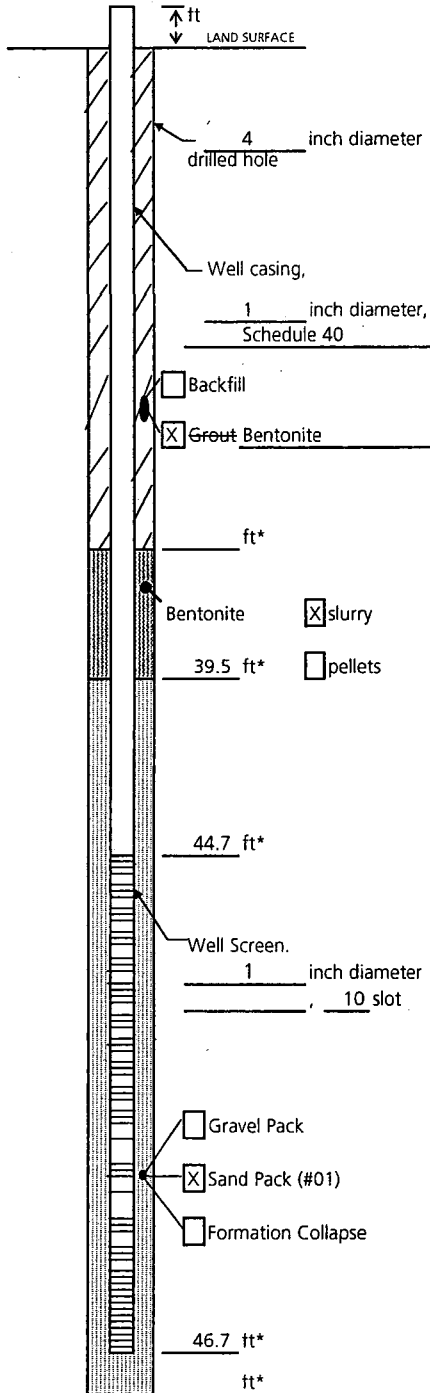

Measuring Point is
Top of Well Casing
Unless Otherwise Noted.

* Depth Below Land Surface

Project NJ000389.0007.00001 Well BS-10

Town/City Harriman

County Orange State NY

Permit No. _____

Land-Surface Elevation and Datum:

_____ feet Surveyed
 Estimated

Installation Date(s) 11/9/2001

Drilling Method Mud Rotary

Drilling Contractor Kendrick Drilling

Drilling Fluid EZ Mud

Development Technique(s) and Date(s)

Fluid Loss During Drilling _____ gallons

Water Removed During Development _____ gallons

Static Depth to Water _____ feet below M.P.

Pumping Depth to Water _____ feet below M.P.

Pumping Duration _____ hours

Yield _____ gpm Date _____

Specific Capacity _____ gpm/ft

Well Purpose Expanded Bio Sparge System-

Sparge Well

Remarks _____

Prepared by G. Horn

Well Construction Log

(Unconsolidated)

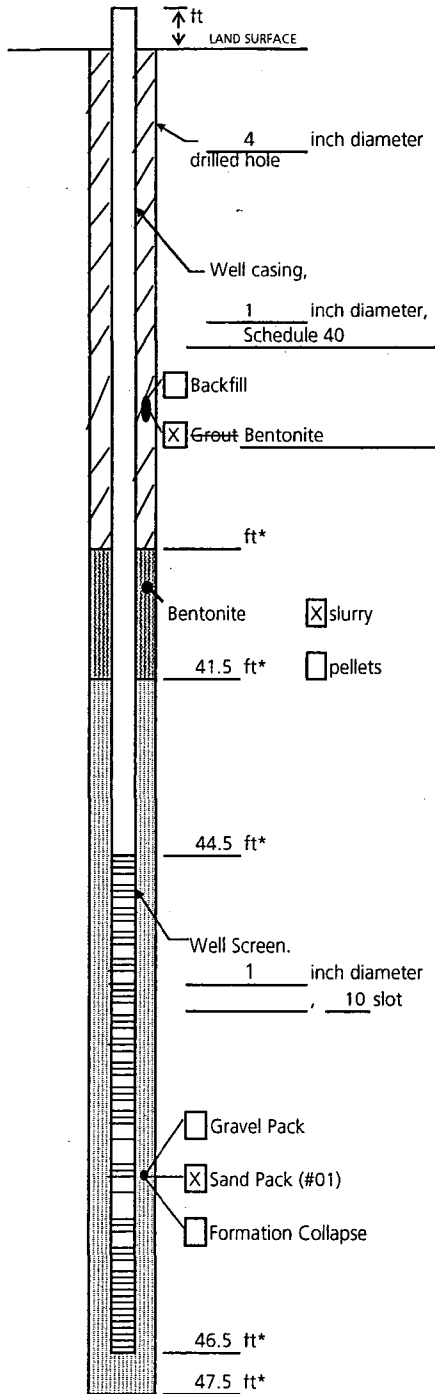

Measuring Point is
Top of Well Casing
Unless Otherwise Noted.

* Depth Below Land Surface

Project NJ000389.0007.00001 Well BS-

Town/City Harriman

County Orange State NY

Permit No. _____

Land-Surface Elevation and Datum:

_____ feet Surveyed
 Estimated

Installation Date(s) 11/12/2001

Drilling Method Mud Rotary

Drilling Contractor Kendrick Drilling

Drilling Fluid EZ Mud

Development Technique(s) and Date(s)

Fluid Loss During Drilling _____ gallons

Water Removed During Development _____ gallons

Static Depth to Water _____ feet below M.P.

Pumping Depth to Water _____ feet below M.P.

Pumping Duration _____ hours

Yield _____ gpm Date _____

Specific Capacity _____ gpm/ft

Well Purpose Expanded Bio Sparge System-

Sparge Well

Remarks _____

Prepared by G. Horn

Well Construction Log
(Unconsolidated)

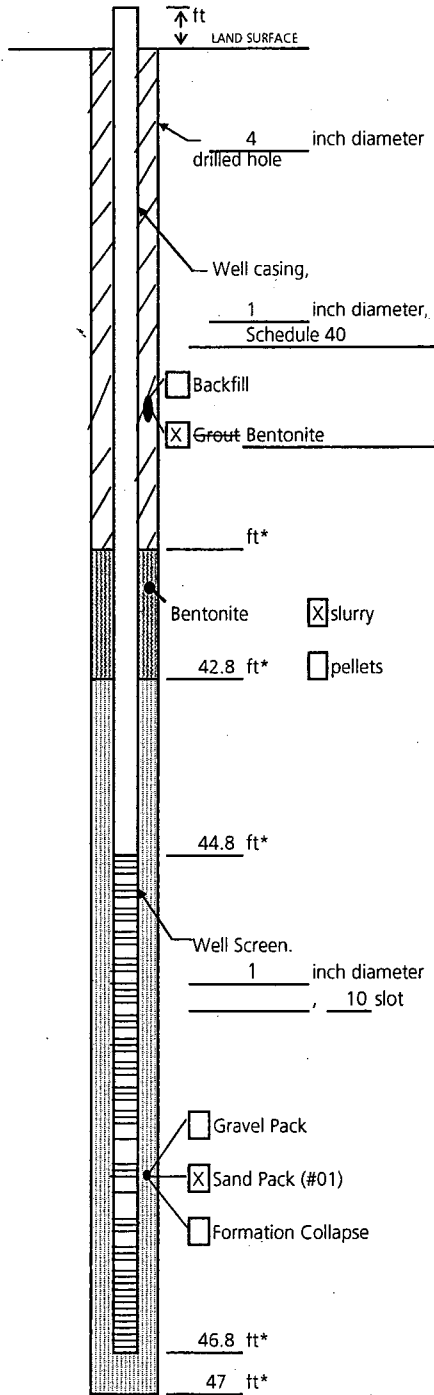

Measuring Point is
Top of Well Casing
Unless Otherwise Noted.

* Depth Below Land Surface

Project NJ000389.0007.00001 Well BS-12

Town/City Harriman

County Orange State NY

Permit No. _____

Land-Surface Elevation and Datum:
_____ feet Surveyed
 Estimated

Installation Date(s) 11/13/2001

Drilling Method Mud Rotary

Drilling Contractor Kendrick Drilling

Drilling Fluid EZ Mud

Development Technique(s) and Date(s)

Fluid Loss During Drilling _____ gallons

Water Removed During Development _____ gallons

Static Depth to Water _____ feet below M.P.

Pumping Depth to Water _____ feet below M.P.

Pumping Duration _____ hours

Yield _____ gpm Date _____

Specific Capacity _____ gpm/ft

Well Purpose Expanded Bio Sparge System-

Sparge Well _____

Remarks _____

Prepared by G. Horn

Well Construction Log

(Unconsolidated)

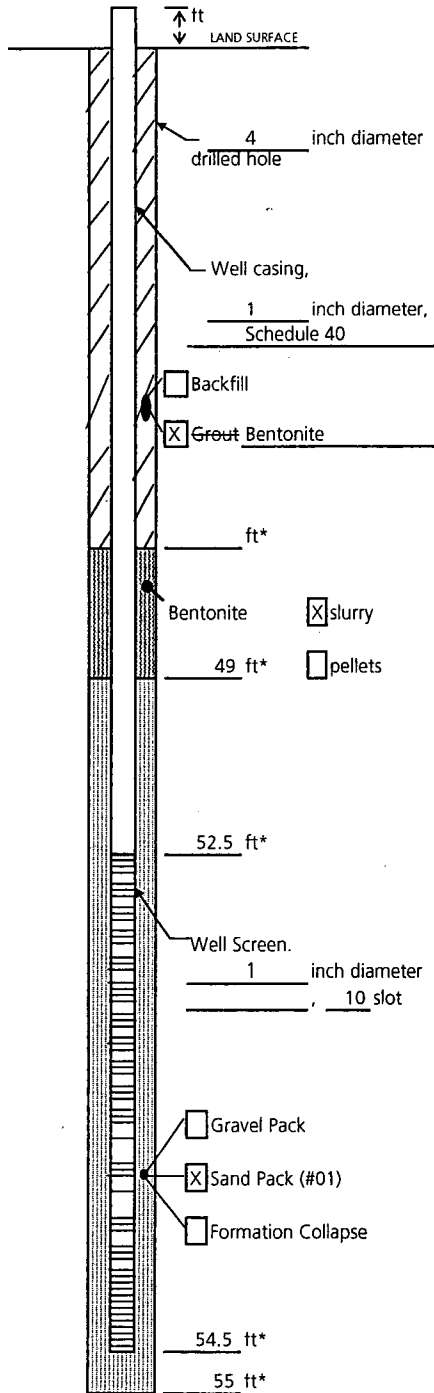

Measuring Point is Top of Well Casing Unless Otherwise Noted.

* Depth Below Land Surface

Project NJ000389.0007.00001 Well B5-13

Town/City Harriman

County Orange State NY

Permit No. _____

Land-Surface Elevation and Datum:

_____ feet Surveyed Estimated

Installation Date(s) 11/13/2001

Drilling Method Mud Rotary

Drilling Contractor Kendrick Drilling

Drilling Fluid EZ Mud

Development Technique(s) and Date(s)

Fluid Loss During Drilling _____ gallons

Water Removed During Development _____ gallons

Static Depth to Water _____ feet below M.P.

Pumping Depth to Water _____ feet below M.P.

Pumping Duration _____ hours

Yield _____ gpm Date _____

Specific Capacity _____ gpm/ft

Well Purpose Expanded Bio Sparge System-

Sparge Well _____

Remarks _____

Prepared by G. Horn

Well Construction Log

(Unconsolidated)

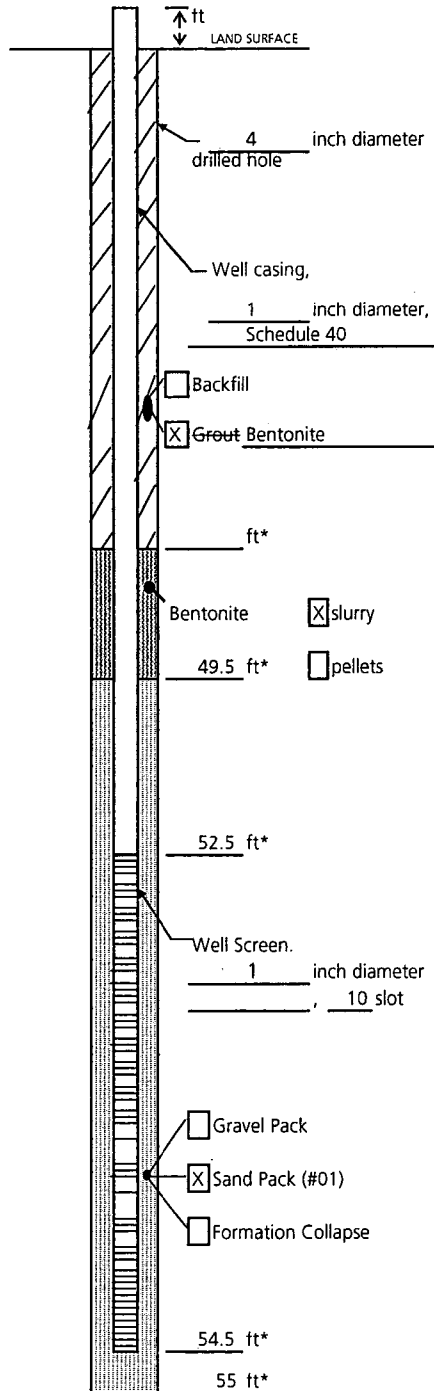

Measuring Point is
Top of Well Casing
Unless Otherwise Noted.

* Depth Below Land Surface

Project NJ000389.0007.00001 Well BS-14

Town/City Harriman

County Orange State NY

Permit No. _____

Land-Surface Elevation and Datum:

_____ feet Surveyed
 Estimated

Installation Date(s) _____

Drilling Method Mud Rotary

Drilling Contractor Kendrick Drilling

Drilling Fluid EZ Mud

Development Technique(s) and Date(s)

Fluid Loss During Drilling _____ gallons

Water Removed During Development _____ gallons

Static Depth to Water _____ feet below M.P.

Pumping Depth to Water _____ feet below M.P.

Pumping Duration _____ hours

Yield _____ gpm Date _____

Specific Capacity _____ gpm/ft

Well Purpose Expanded Bio Sparge System-

Sparge Well

Remarks _____

Prepared by G. Horn

Well Construction Log

(Unconsolidated)

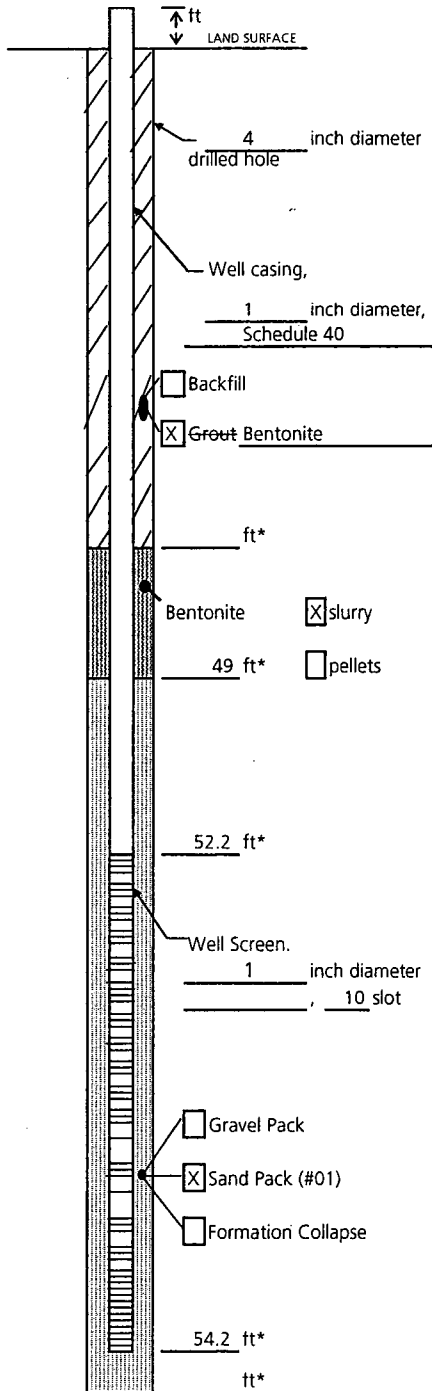

Measuring Point is
Top of Well Casing
Unless Otherwise Noted.

* Depth Below Land Surface

Project NJ000389.0007.00001 Well BS-15

Town/City Harriman

County Orange State NY

Permit No. _____

Land-Surface Elevation and Datum:

_____ feet Surveyed

Estimated

Installation Date(s) 11/8/2001

Drilling Method Mud Rotary

Drilling Contractor Kendrick Drilling

Drilling Fluid EZ Mud

Development Technique(s) and Date(s)

Fluid Loss During Drilling _____ gallons

Water Removed During Development _____ gallons

Static Depth to Water _____ feet below M.P.

Pumping Depth to Water _____ feet below M.P.

Pumping Duration _____ hours

Yield _____ gpm Date _____

Specific Capacity _____ gpm/ft

Well Purpose Expanded Bio Sparge System-

Sparge Well _____

Remarks _____

Prepared by G. Horn

Well Construction Log

(Unconsolidated)

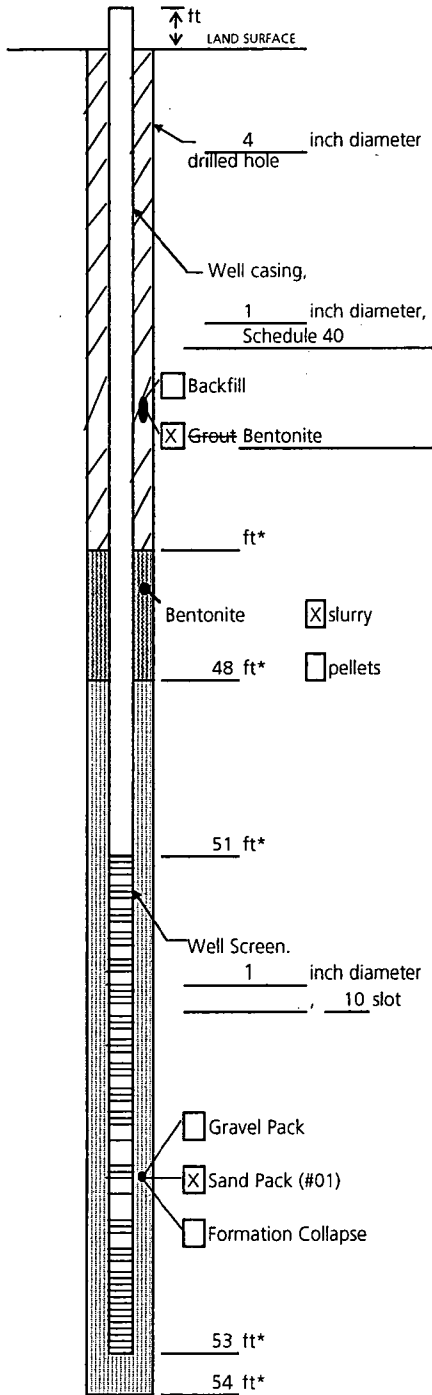

Measuring Point is
Top of Well Casing
Unless Otherwise Noted.

* Depth Below Land Surface

Project NJ000389.0007.00001 Well BS-16

Town/City Harriman

County Orange State NY

Permit No. _____

Land-Surface Elevation and Datum:

_____ feet Surveyed
 Estimated

Installation Date(s) 11/8/2001

Drilling Method Mud Rotary

Drilling Contractor Kendrick Drilling

Drilling Fluid EZ Mud

Development Technique(s) and Date(s)

Fluid Loss During Drilling _____ gallons

Water Removed During Development _____ gallons

Static Depth to Water _____ feet below M.P.

Pumping Depth to Water _____ feet below M.P.

Pumping Duration _____ hours

Yield _____ gpm Date _____

Specific Capacity _____ gpm/ft

Well Purpose Expanded Bio Sparge System-

Sparge Well _____

Remarks _____

Prepared by G. Horn

Well Construction Log

(Unconsolidated)

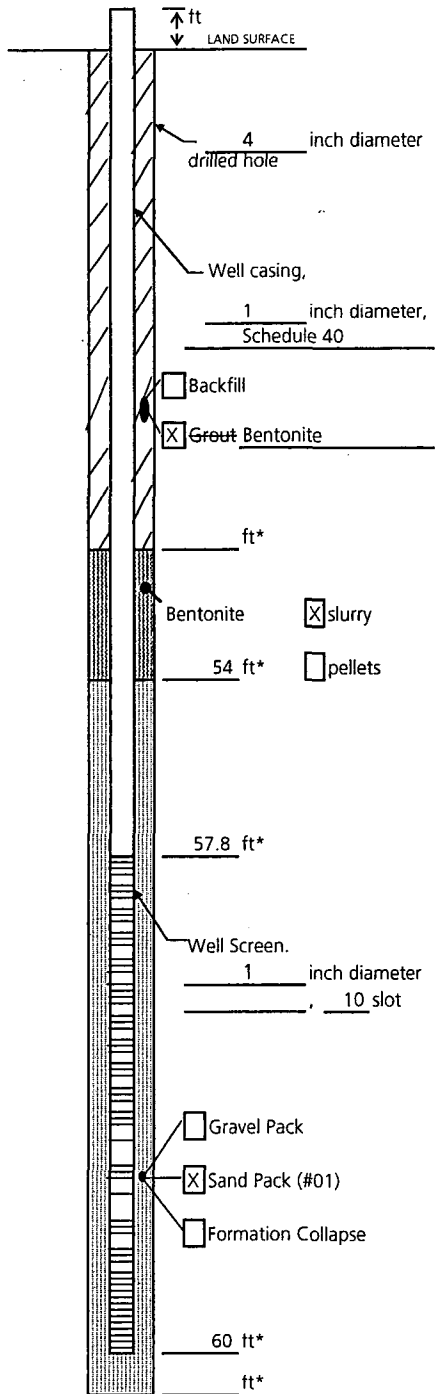

Measuring Point is
Top of Well Casing
Unless Otherwise Noted.

* Depth Below Land Surface

Project NJ000389.0007.00001 Well BS-17

Town/City Harriman

County Orange State NY

Permit No. _____

Land-Surface Elevation and Datum:

_____ feet Surveyed
 Estimated

Installation Date(s) 11/6/2001

Drilling Method Mud Rotary

Drilling Contractor Kendrick Drilling

Drilling Fluid EZ Mud

Development Technique(s) and Date(s)

Fluid Loss During Drilling _____ gallons

Water Removed During Development _____ gallons

Static Depth to Water _____ feet below M.P.

Pumping Depth to Water _____ feet below M.P.

Pumping Duration _____ hours

Yield _____ gpm Date _____

Specific Capacity _____ gpm/ft

Well Purpose Expanded Bio Sparge System-

Sparge Well

Remarks _____

Prepared by G. Horn

Well Construction Log

(Unconsolidated)

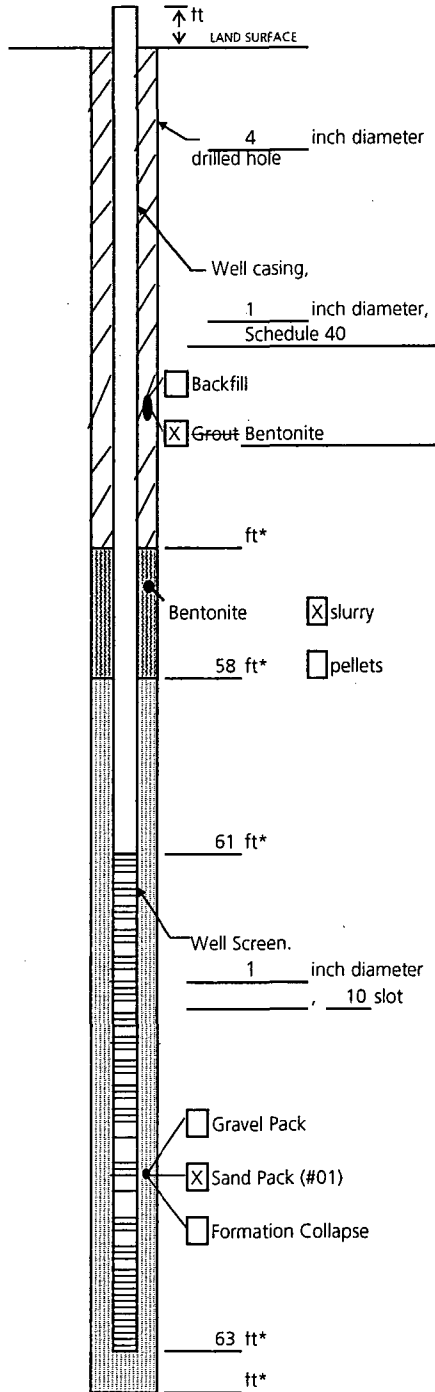

Measuring Point is
Top of Well Casing
Unless Otherwise Noted.

* Depth Below Land Surface

Project NJ000389.0007.00001 Well BS-18

Town/City Harriman

County Orange State NY

Permit No. _____

Land-Surface Elevation and Datum:

_____ feet Surveyed
 Estimated

Installation Date(s) 11/6/2001

Drilling Method Mud Rotary

Drilling Contractor Kendrick Drilling

Drilling Fluid EZ Mud

Development Technique(s) and Date(s)

Fluid Loss During Drilling _____ gallons

Water Removed During Development _____ gallons

Static Depth to Water _____ feet below M.P.

Pumping Depth to Water _____ feet below M.P.

Pumping Duration _____ hours

Yield _____ gpm Date _____

Specific Capacity _____ gpm/ft

Well Purpose Expanded Bio Sparge System-

Sparge Well

Remarks _____

Prepared by G. Horn

Well Construction Log

(Unconsolidated)

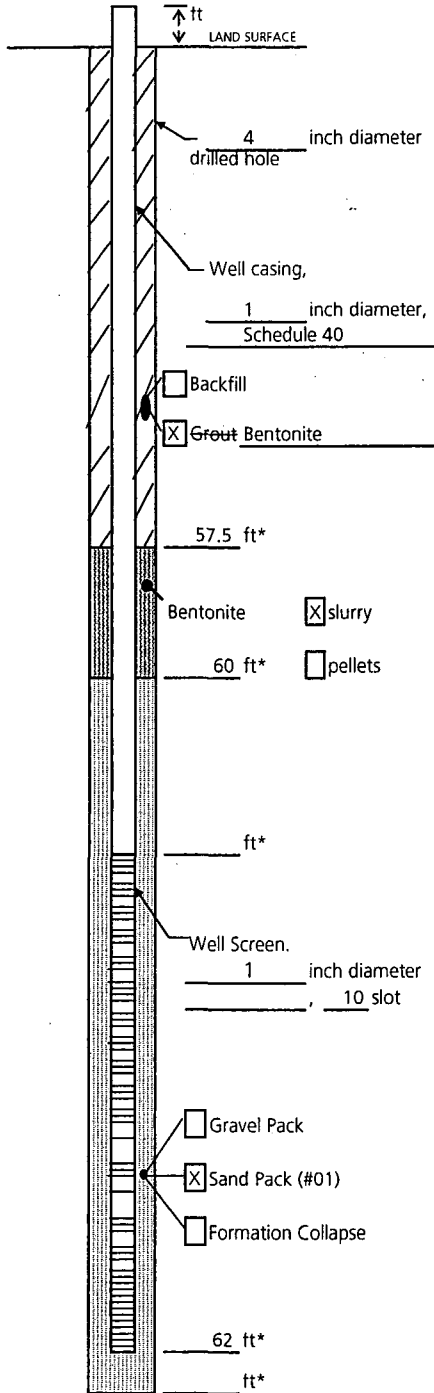

Measuring Point is
Top of Well Casing
Unless Otherwise Noted.

* Depth Below Land Surface

Project NJ000389.0007.00001 Well BS-19

Town/City Harriman

County Orange State NY

Permit No. _____

Land-Surface Elevation and Datum:

_____ feet Surveyed

Estimated

Installation Date(s) 11/7/2001

Drilling Method Mud Rotary

Drilling Contractor Kendrick Drilling

Drilling Fluid EZ Mud

Development Technique(s) and Date(s)

Fluid Loss During Drilling _____ gallons

Water Removed During Development _____ gallons

Static Depth to Water _____ feet below M.P.

Pumping Depth to Water _____ feet below M.P.

Pumping Duration _____ hours

Yield _____ gpm Date _____

Specific Capacity _____ gpm/ft

Well Purpose Expanded Bio Sparge System-

Sparge Well

Remarks _____

Prepared by G. Horn

Well Construction Log
(Unconsolidated)

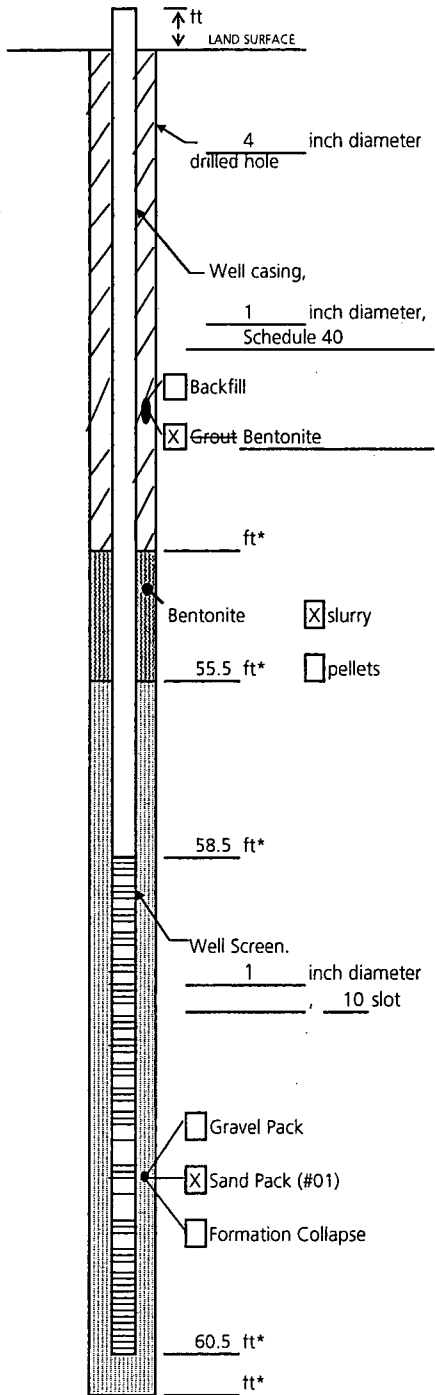

Measuring Point is
Top of Well Casing
Unless Otherwise Noted.

* Depth Below Land Surface

Project NJ000389.0007.00001 Well BS-20

Town/City Harriman

County Orange State NY

Permit No. _____

Land-Surface Elevation and Datum:
_____ feet Surveyed
 Estimated

Installation Date(s) 11/7/2001

Drilling Method Mud Rotary

Drilling Contractor Kendrick Drilling

Drilling Fluid EZ Mud

Development Technique(s) and Date(s)

Fluid Loss During Drilling _____ gallons

Water Removed During Development _____ gallons

Static Depth to Water _____ feet below M.P.

Pumping Depth to Water _____ feet below M.P.

Pumping Duration _____ hours

Yield _____ gpm Date _____

Specific Capacity _____ gpm/ft

Well Purpose Expanded Bio Sparge System-

Sparge Well

Remarks _____

Prepared by G. Horn



LOCATION OF SURVEY CONTROL POINTS
(TOE OF SLOPE AT ELEV. 521')

Survey Pt	a'	b'	c'	d'	e'	f'	g'	h'	j'	k'	m'	n'
Distance	563	563	498	228	205	167	150	113	90	90	170	483
Distance	80	240	318	363	363	353	348	318	267	80	0	0

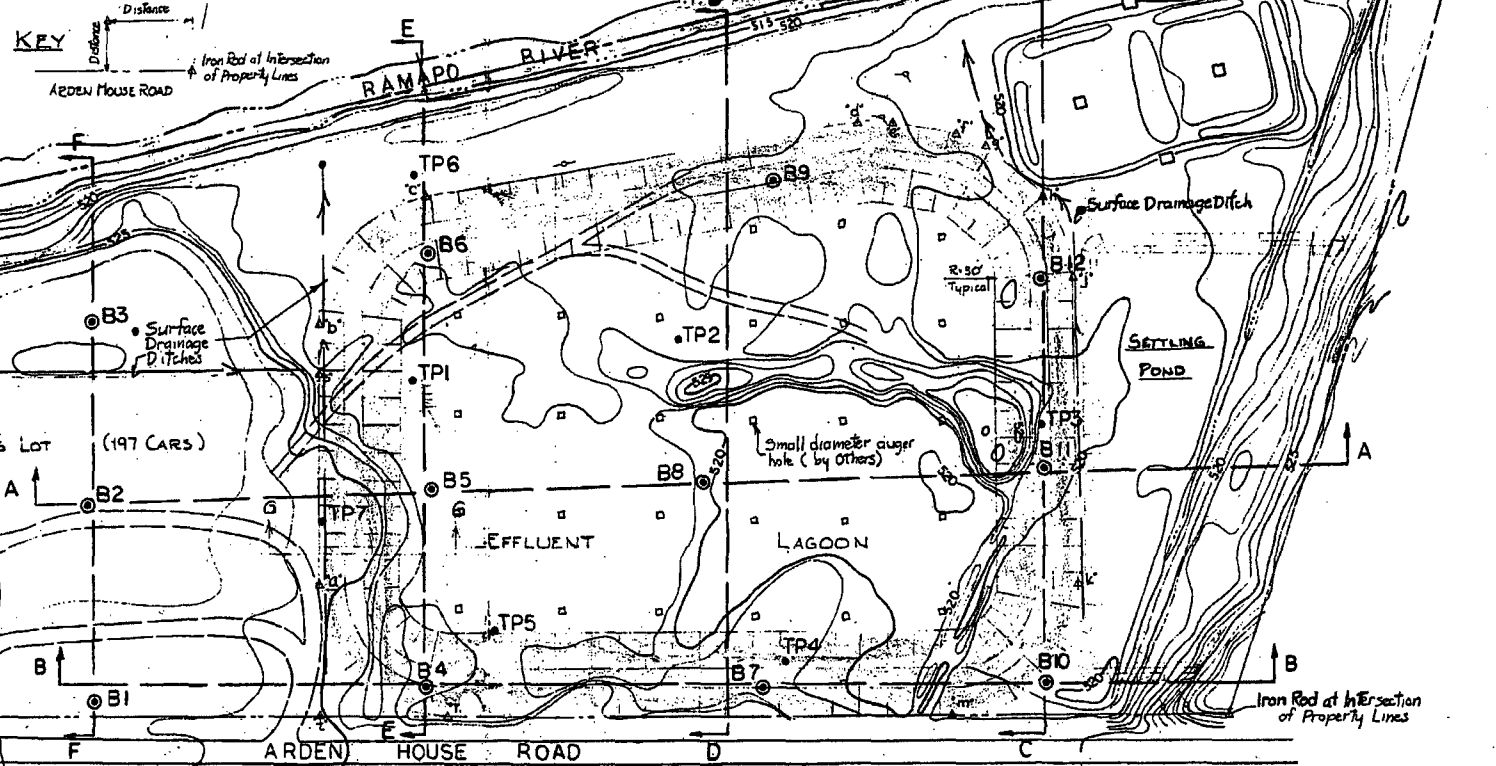

PLAN OF BORINGS & TEST PITS

Scale 1 in = 50 ft
NOTE: NOT TO SCALE (REDUCED DWG)

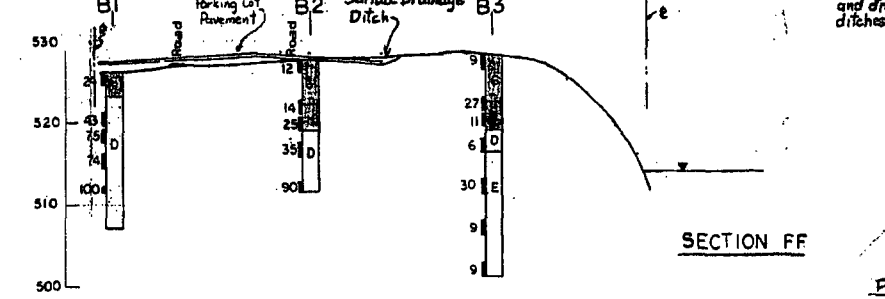
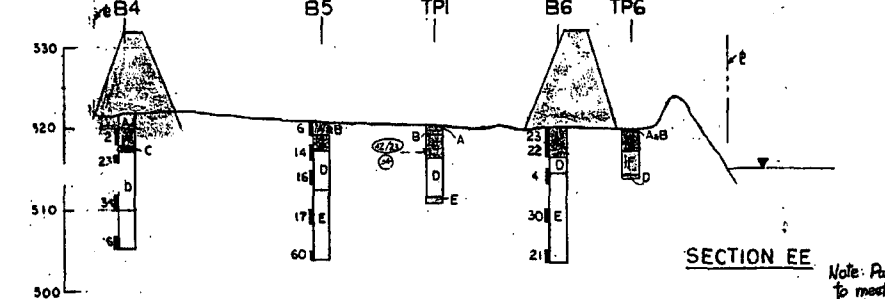
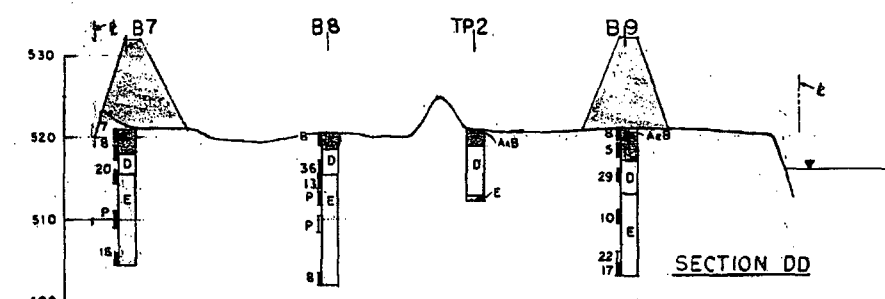
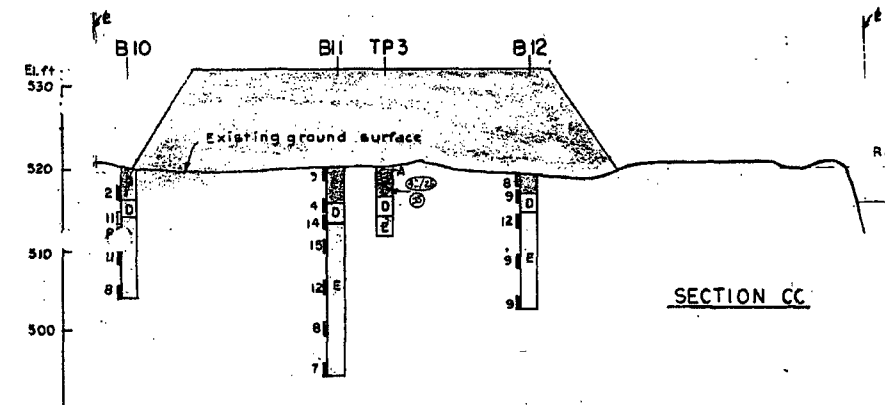
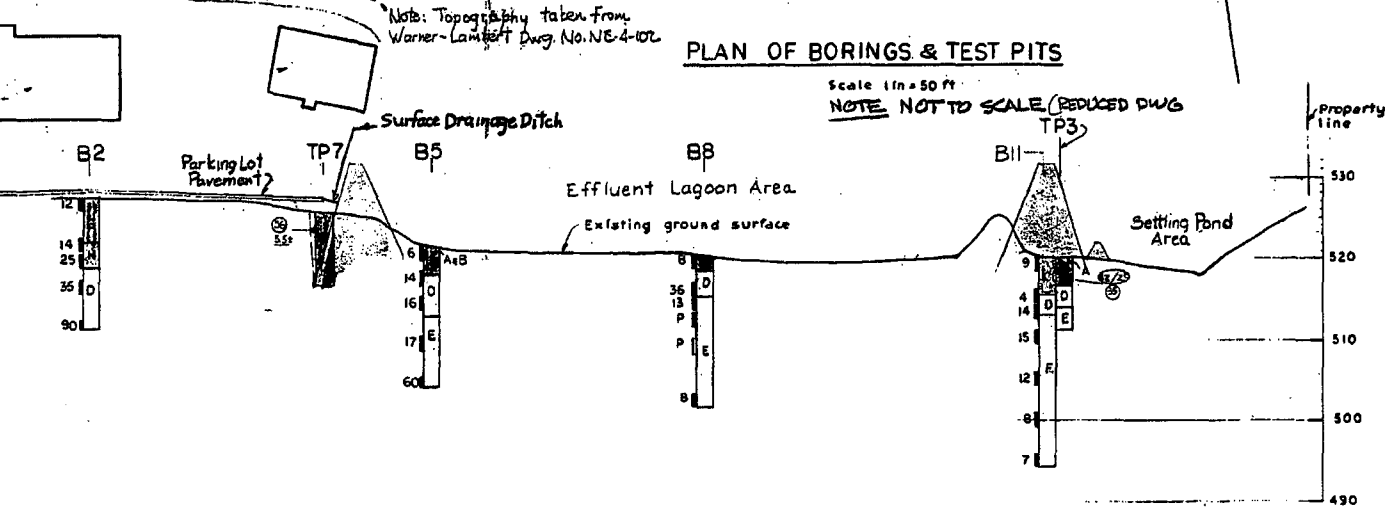

GENERALIZED SOIL PROFILES

Horiz. Scale 1 in = 50 ft
Vert. Scale 1 in = 10 ft

- LEGEND:
- Roots and topsoil-organic
 - Brown sandy topsoil
 - Brown-gray clayey silt to silty clay, trace to little fine sand
 - Gray to gray-black sandy gravel to gravelly sand w/cobbles and occasional boulders
 - Blue-gray silt w/occasional thin varves of clay
 - Gray-brown clayey silty sand (very dense) w/many cobbles and boulders
 - Chemical waste
 - Black organic clayey silt w/roots

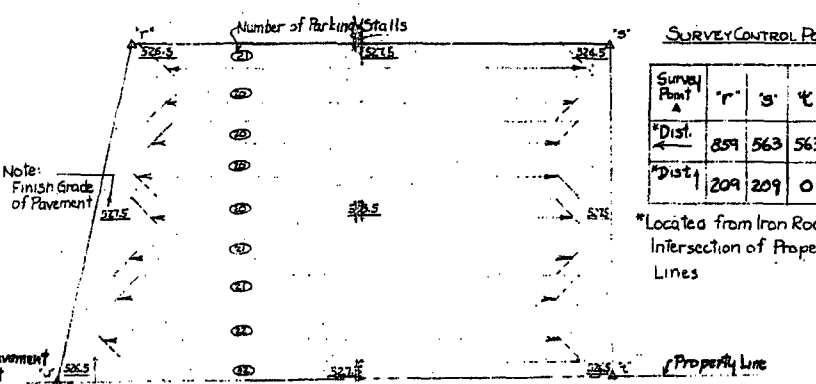
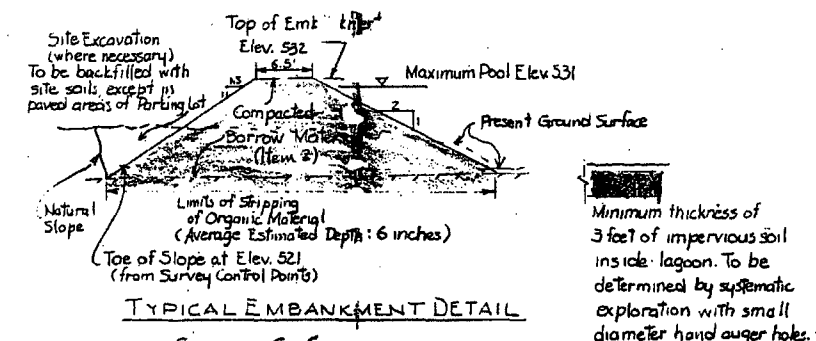

Survey Point	r'	s'	t'	u'
*Dist.	859	563	563	903
*Dist.	209	209	0	0

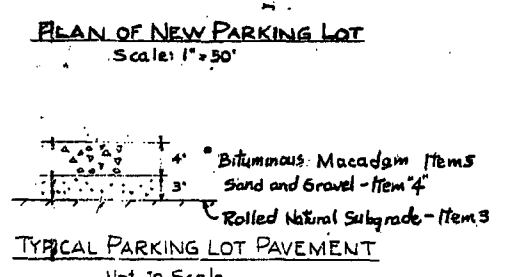

PRELIMINARY

EARTHWORK & GRADING PLANS

EFFLUENT LAGOON & PARKING LOT
NEPERA CHEMICAL COMPANY
HARRIMAN, NEW YORK

FOR: WARNER LAMBERT PHARMACEUTICAL CO.
CENTRAL ENGINEERING DEPARTMENT

BY: WOODWARD, CLYDE, SHERARD & ASSOC.

DATE: 2/64 SCALE: As Noted DWG. NO. EW-1

NEPERA - ROLL FILE #2
REF. DWG. #FP-43-015



APPENDIX E



Appendix E

Benzene, Pyridine and Alpha-Picoline
Concentrations Graph

MW-20S

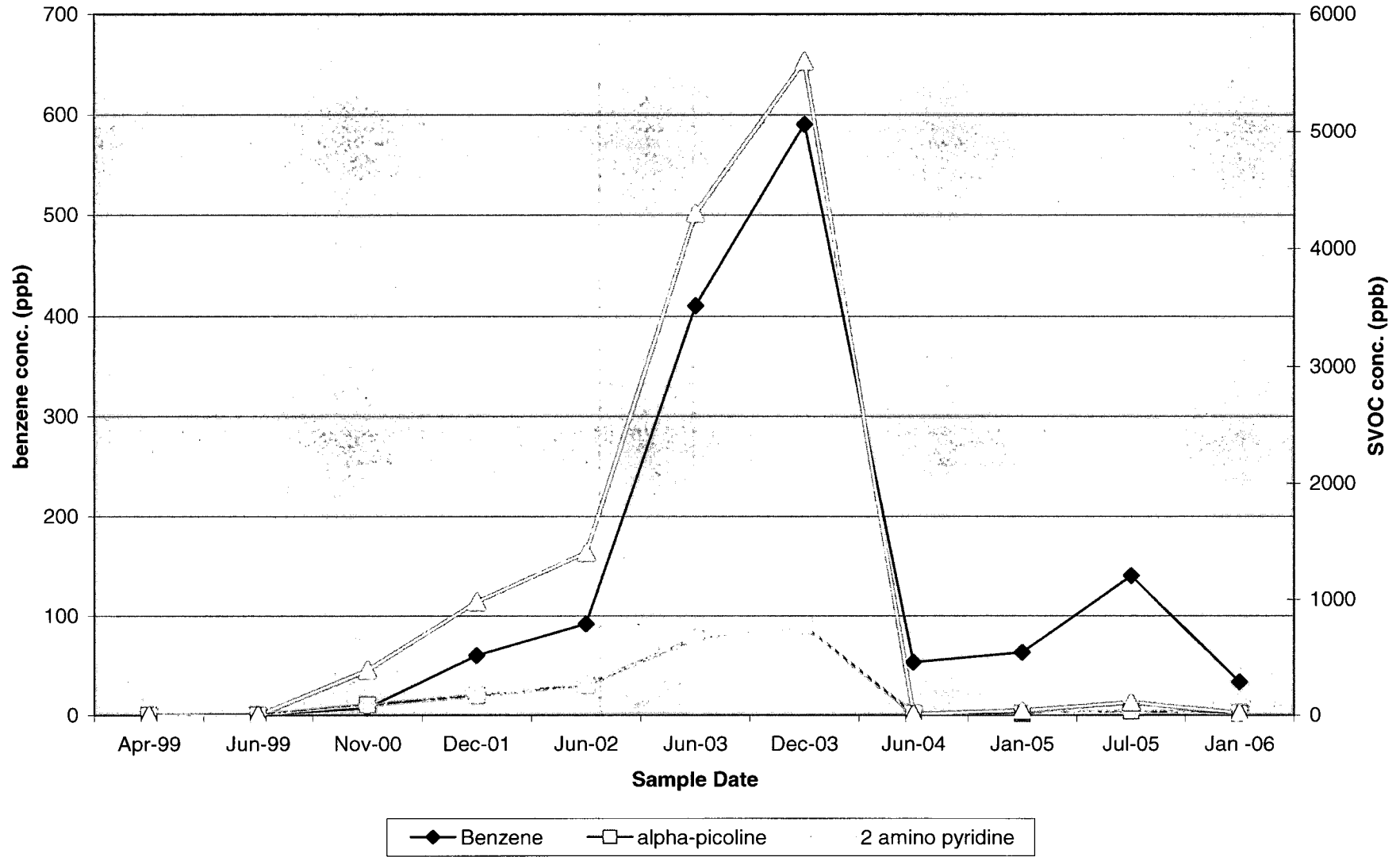

OW-6

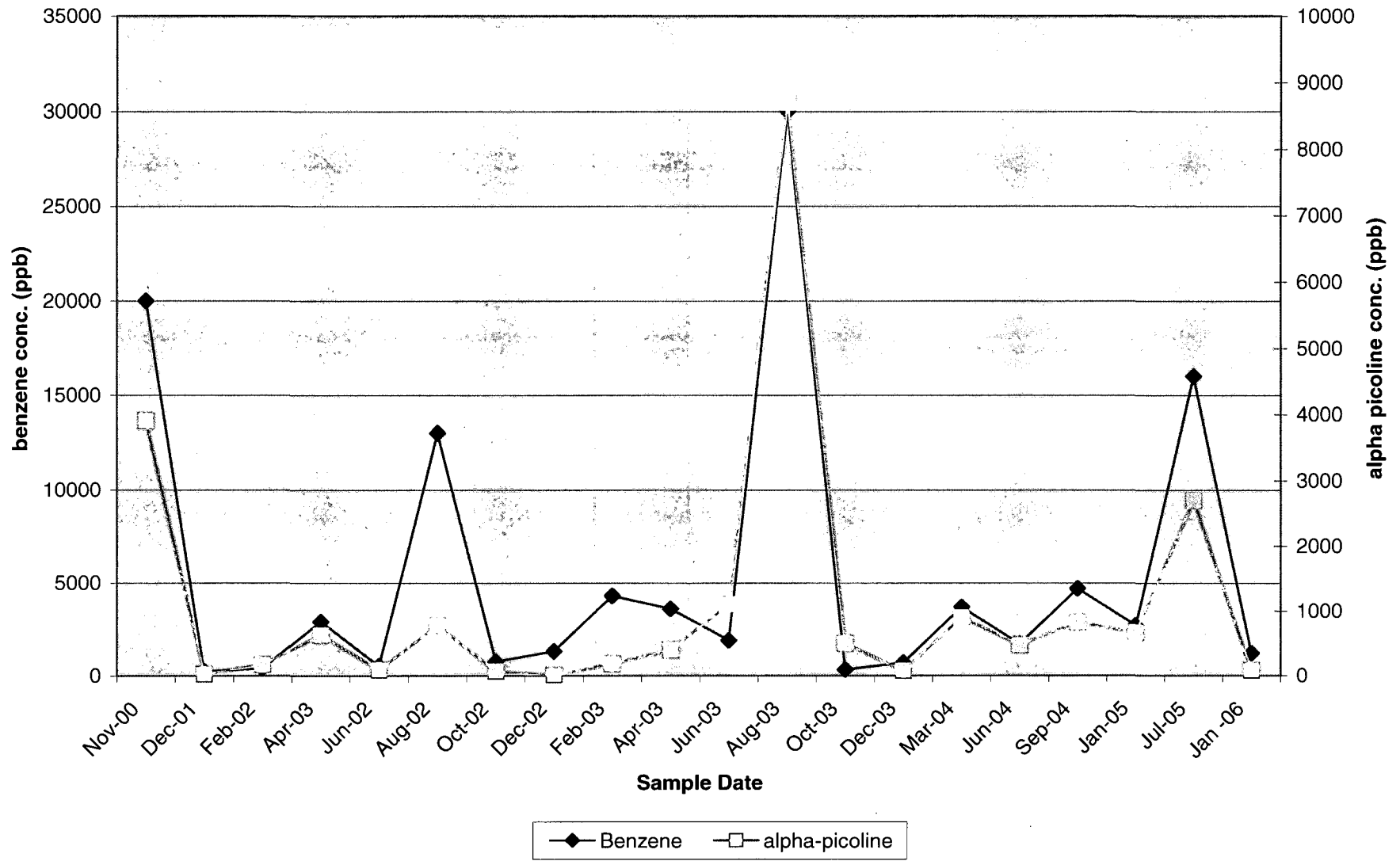

MW-16S

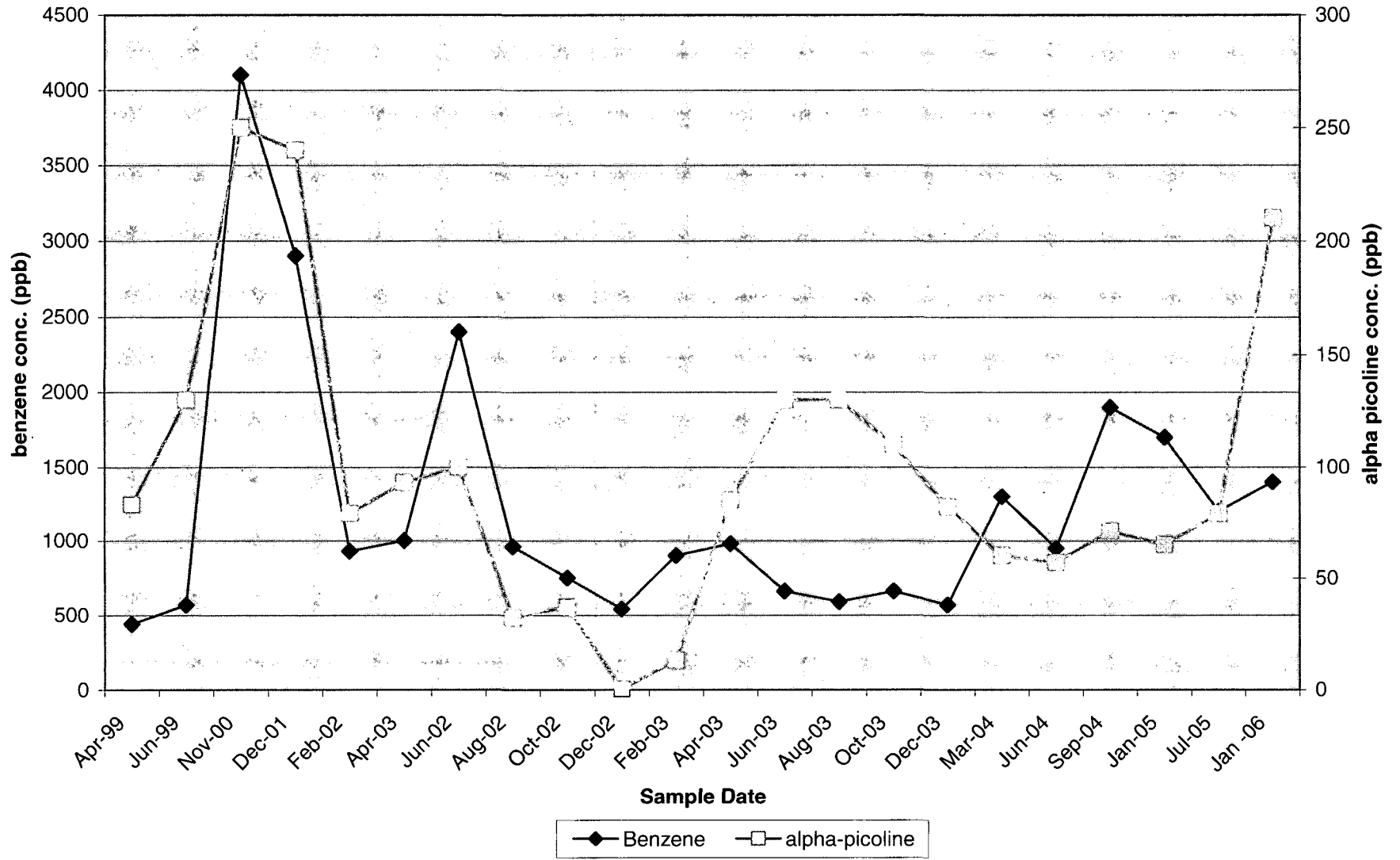



Appendix F

1988 Town of Harriman Water Supply
Well OR-7 Pumping Test Report

**INCREASED PUMP RATE TEST ANALYSIS
WELL OR-7
VILLAGE OF HARRIMAN
HARRIMAN, NEW YORK**

Prepared For

Village of Harriman

July 1998

Prepared By

LEGGETTE, BRASHEARS & GRAHAM, INC.
Professional Ground-Water and Environmental Engineering Services
126 Monroe Turnpike
Trumbull, CT 06611

TABLE OF CONTENTS

	<u>Page</u>
INTRODUCTION	1
WELL OR-7	1
March 30 to April 2, 1998 Pumping Test	1
Long-Term Yield of OR-7	2
WELL MONITORING PROGRAM	2
WATER QUALITY	4
CONCLUSIONS	4
RECOMMENDATIONS	5

LIST OF APPENDICES
(at end of report)

Appendix

- I Hydrograph and Water-Level Readings During 72-Hour Pumping Test from March 30 - April 2, 1998
- II Hydrograph of Monitoring Wells During 72-Hour Pumping Test from March 30 - April 2, 1998
- III Water-Quality Analysis for Well OR-7

PLATE
(in pocket)

Plate

- 1 Production and Monitoring Well Location Map

**INCREASED PUMP RATE TEST ANALYSIS
WELL OR-7
VILLAGE OF HARRIMAN
HARRIMAN, NEW YORK**

INTRODUCTION

Leggette, Brashears & Graham, Inc. (LBG) conducted a 72-hour pumping test on Well OR-7, with an offsite well monitoring program. Well OR-7 is presently permitted by the New York State Department of Environmental Conservation (NYSDEC) for water-taking of up to 50 gpm (gallons per minute). The well was reported to yield from up to 150 gpm during drilling. The Village would like to increase the permitted water taking from 50 to 125 gpm. Special attention was directed to evaluating the possibility of inducing ground-water contamination from the Nepera site at the increased pump rate.

WELL OR-7

The well was drilled by Turnbull Well Drilling Association under the supervision of CA Rich Consultants, Inc. Well OR-7 was completed utilizing an 8-inch diameter casing installed to a depth of 55 feet and grouted into place. The overburden material encountered during drilling consisted of 33 feet of a silty clay. The bedrock encountered during drilling from 33 feet to the completion depth of 417 feet was a hard competent dolomite bedrock unit. Two significant water-bearing zones were encountered at 53 feet and 370 feet, respectively. The casing was advanced approximately 2 feet below the 53-foot fracture to seal off this shallow fracture zone off, thereby providing the well with a deeper water-bearing zone less likely to be impacted from ground-water contamination sources in the region.

March 30 to April 2, 1998 Pumping Test

In February 1998, John Karl, Village of Harriman Water Superintendent, contracted Quackenbush Water Systems to install a 25 hp (horsepower) Grundfos submersible pump in OR-7 at a depth of 370 feet. A 1-inch diameter plastic access tube for manual measurements of water

levels was installed with the pump. The flow rate was measured with a flow meter. Well OR-7 is located on plate 1.

OR-7 was pumped at a constant rate of 148 gpm for the entire test. At the rate of 148 gpm, the water level declined from a pre-test static water level of 13.9 feet to 203.8 feet immediately prior to the end of the test. The total drawdown at the end of the test was 189.9 feet. Substantial yield and drawdown stabilization was achieved for the last eight hours of the test. Water-level data measurements collected during the pumping test and plots of the data for OR-7 are shown in Appendix I.

After the test was terminated, recovery measurements were made in OR-7 for a period of one hour. The water-level plot shown in Appendix I shows that the water level in Well OR-7 recovered from 203.8 feet to 69.3 feet in one hour. Recovery continued and in approximately four days, the water level was fully recovered.

Long-Term Yield of OR-7

The data from the pumping test indicated OR-7 is a reliable source of water and can be pumped at rates of up to 148 gpm. The test data indicated that at a rate of 148 gpm, the pumping water level stabilizes at about 203 below the top of the casing. This is approximately 167 feet above the major water-bearing zone penetrated by the borehole, affording a significant amount of available drawdown.

WELL MONITORING PROGRAM

During the March 30 to April 2, 1998 pumping test on OR-7, a well monitoring program was conducted on the ICC and Nepera property to evaluate the possibility of inducing the migration of contaminants from the Nepera site at a higher pumping rate. Nepera is currently under an "Order of Consent" with the NYSDEC as a result of the confirmed presence of a ground-water contamination problem at the Nepera facility. The ground-water contamination problem is limited to a small area within the shallow overburden material.

Nepera has been active and completed a Remedial Investigation/Feasibility Study. The pump and treat portion of the study insures that no contamination migration can likely occur. The monitoring well network in place since 1987 has historically indicated no evidence of offsite ground-water contamination migration from the Nepera site and the ground-water contamination is limited to a small area over 3,500 feet southwest of OR-7. In addition, the data from the monitoring program indicates the contamination is limited to the shallow overburden material and has not migrated to the underlying bedrock aquifer.

During the pumping test, a monitoring well network, including four cluster well locations which consisted of a monitoring well completed in both the shallow saturated overburden material and a bedrock well and one additional bedrock well were monitored. The monitoring wells are shown on plate 1. The purpose of the well monitoring program was to determine if the pumping of OR-7 at a maximum pumping rate for 72 hours would significantly affect water levels in monitoring wells within close proximity to Nepera and if there was a direct hydraulic connection between the saturated overburden material and underlying bedrock aquifer. The hydrographs for the monitoring wells are located in Appendix II.

The water levels of Monitoring Wells S-3, S-4, MW-6, MW-7, D-2, MW-23S and MW-23D show some minor fluctuations not attributed to the pumping of OR-7. The hydrographs for these wells indicate no discernible drawdown from pumping OR-7.

Two of the closest bedrock monitoring wells, D-3 and D-4, located about 1,500 feet and 1,200 feet, respectively, from OR-7 indicated 4.4 feet and 12.4 feet of drawdown from pumping OR-7 near the end of the 72-hour pumping test. During the pumping test conducted on OR-7 in June of 1988 at a rate of 50 gpm, water-level drawdown (2+ feet) was observed in bedrock monitoring wells approximately 1,100 feet from OR-7. Data indicated at the increased pumping rate the drawdown diminishes as distance increases from the pumping well (OR-7) and does not appear to extend beyond Monitoring Well D-2 located approximately 1,800 feet southwest of OR-7.

The data indicate no water-level drawdown in any of the overburden monitoring wells from pumping the bedrock aquifer (OR-7). Based on drilling logs for OR-7 and logs of other supply wells and monitoring wells on ICC/Nepera, a till or "hardpan" layer apparently extends from the upland

areas to beneath the Ramapo River Valley. This till, encountered beneath the other valley fill material, is extremely dense and impermeable and forms an effective lower confining layer for the bedrock aquifer. In addition, the logs of the test boring on the ICC/Nepera sites indicate a sufficient clayey and silt content near the surface to consider them safe from shallow subsurface contamination. The above pump test data collected during the test on OR-7 and available geologic data strongly indicates no direct hydraulic connection between the shallow saturated overburden material and the significant water-bearing zone encountered in the bedrock aquifer during the drilling of OR-7.

WATER QUALITY

Water samples were collected near the end of the pumping test. The samples were delivered to OCL Laboratories in Bloomingburg, New York and analyzed by EPA Method 502.2 for volatile organic compounds (VOCs). All constituents were found at levels below the detection limits, with the exception of methylene chloride at 1.1 ug/l (micrograms per liter). Methylene chloride is a typical in-house laboratory contaminant. A copy of the laboratory report is located in Appendix III.

CONCLUSIONS

Based on the results of the March 30 to April 2, 1998 pumping test on OR-7, the well has a sustainable yield capacity of up to 148 gpm. The well can supply about 160,000 if pumped up to 18 hours daily. LBG strongly recommends the well not be pumped more than 18 hours on a daily basis.

The water-quality analysis of OR-7 indicates no water-quality impact from ground-water contamination on the Nepera site. The monitoring well network onsite and offsite Nepera, in place since 1987, has historically indicated no evidence of offsite migration of ground-water contamination from the Nepera site. The ground-water contamination at the Nepera site is limited to the shallow overburden material in a small area over 3,500 feet southwest of OR-7. Nepera's onsite remediation plan includes a pump and treat facility to insure no contamination migration can likely occur.

The above data strongly indicate the pumping of OR-7 at rates up to 148 gpm would not likely induce migration or redirect the ground-water contamination located on the Nepera site.

RECOMMENDATIONS

LBG recommends OR-7 be placed in service at a conservative rate of 125 gpm, although under emergency conditions, the well can be pumped up to rates not to exceed 148 gpm.

The Village should sample OR-7 on a quarterly basis for EPA Method 502.2 for the presence of VOCs.

LEGGETTE, BRASHEARS & GRAHAM, INC.

Thomas P. Cusack
Associate

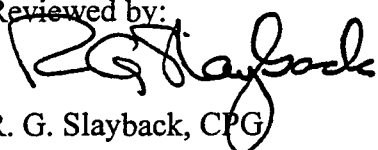

Reviewed by:

R. G. Slayback, CPG
President

cmp
July 9, 1998
H:\HARRIMAN\1998\WELLOR7.RPT

APPENDIX I

**Hydrograph and Water-Level Readings During
72-Hour Pumping Test from March 30 - April 2, 1998**

VILLAGE OF HARRIMAN HARRIMAN, NEW YORK

Hydrograph of Well OR-7 During 72-Hour Pumping Test
from March 30 - April 2, 1998

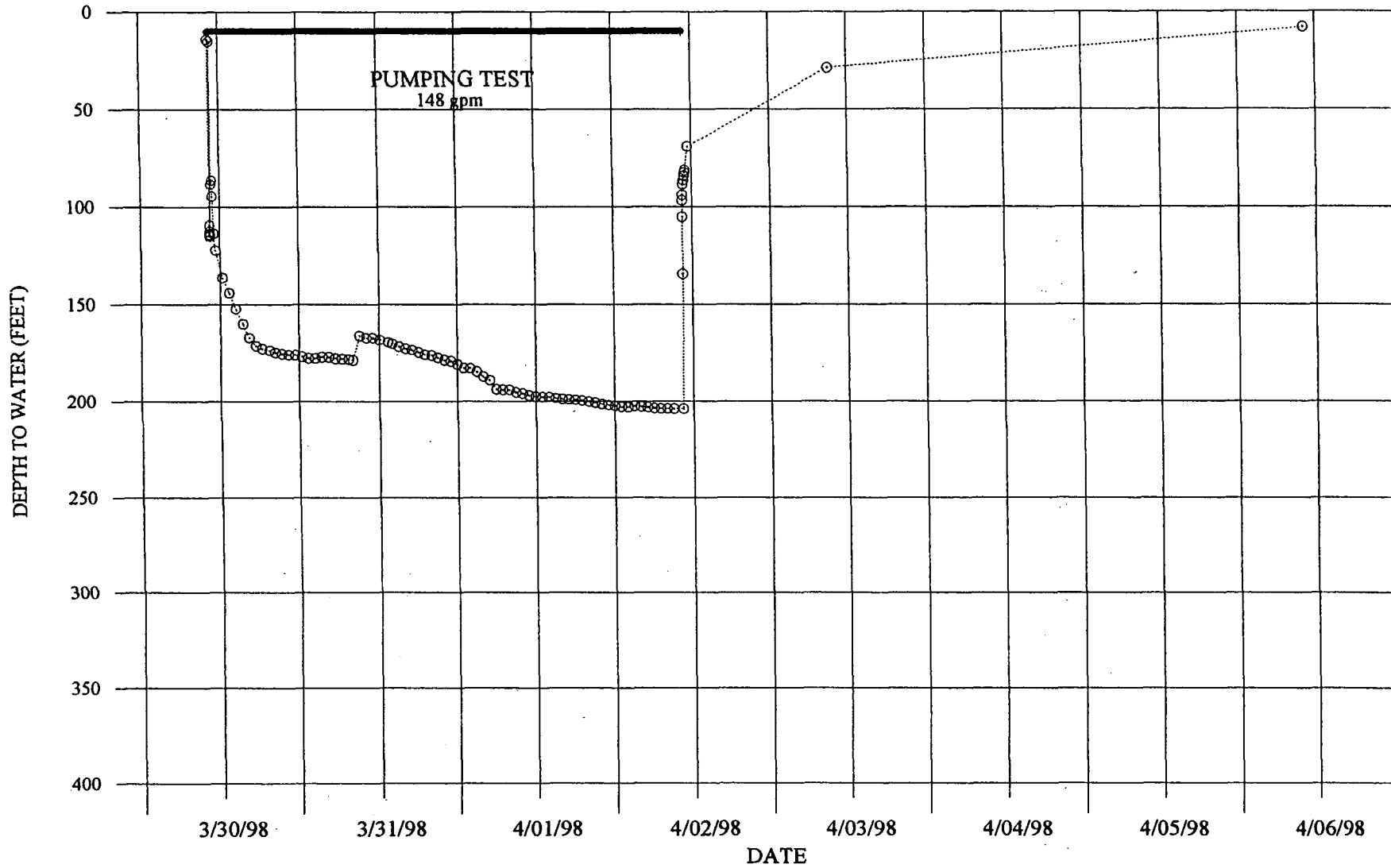

**VILLAGE OF HARRIMAN
HARRIMAN, NEW YORK**

OR-7

**Water Level and Pumping Rate Readings During
72-hour Pumping Test on OK-7 Well
from March 30 - April 2, 1998**

Date	Time (military)	Depth to water (feet)	Elapsed Time (minutes)	Remarks
03/30/98	10:20	13.90	0	Pump On 148 gpm
	10:27	109.52	7	
	10:28	112.60	8	
	10:29	113.96	9	
	10:30	114.90	10	
	10:35	-	15	Q adjusted to 148 gpm
	10:40	88.30	20	
	10:45	86.25	25	
	10:50	94.60	30	
	11:05	113.60	45	
	11:20	122.10	60	
	12:20	136.20	120	
	13:20	144.00	180	
	14:20	152.17	240	
	15:27	160.00	307	
	16:20	167.14	360	
	17:20	171.38	420	
	18:20	172.91	480	
	19:30	173.82	550	
	20:20	174.91	600	
	21:20	175.57	660	
	22:20	175.93	720	
	23:20	176.02	780	
03/31/98	00:20	176.81	840	
	01:20	177.72	900	
	02:20	177.82	960	
	03:20	177.07	1020	
	04:20	177.22	1080	
	05:20	177.89	1140	
	06:20	178.13	1200	
	07:20	178.42	1260	
	08:00	178.80	1300	
	09:00	166.30	1360	Q adjusted to 148 gpm
	10:00	167.40	1420	
	11:00	167.34	1480	
	12:00	168.30	1540	
	13:20	169.57	1620	
	14:00	170.40	1660	
03/31/98	15:00	171.92	1720	148 gpm

**VILLAGE OF HARRIMAN
HARRIMAN, NEW YORK**

**OR-7
Water Level and Pumping Rate Readings During
72-hour Pumping Test on OK-7 Well
from March 30 - April 2, 1998
(continued)**

Date	Time (military)	Depth to water (feet)	Elapsed Time (minutes)	Remarks
03/31/98	16:00	172.81	172.81	148 gpm
	17:00	173.54	173.54	
	18:00	174.78	174.78	
	19:00	176.00	176.00	
	20:00	176.32	176.32	
	21:00	177.57	177.57	
	22:00	178.91	178.91	
	23:00	179.42	179.42	
04/01/98	00:00	180.98	180.98	
	01:00	182.93	182.93	
	02:00	183.00	183.00	
	03:00	184.77	184.77	
	04:00	187.21	187.21	
	05:00	189.11	189.11	
	06:00	193.77	193.77	
	07:00	194.00	194.00	
	08:00	194.10	194.10	
	09:00	195.40	195.40	
	10:00	195.90	195.90	
	11:00	197.00	197.00	
	12:00	197.51	197.51	
	13:00	197.83	197.83	
	14:00	197.90	197.90	
	15:00	198.42	198.42	
	16:00	198.83	198.83	
	17:00	199.00	199.00	
	18:00	199.21	199.21	
	19:00	199.52	199.52	
	20:00	200.11	200.11	
	21:00	200.73	200.73	
	22:00	201.42	201.42	
	23:00	201.87	201.87	
04/02/98	00:00	202.43	202.43	
	01:00	202.92	202.92	
	02:00	203.00	203.00	
	03:00	202.52	202.52	
	04:00	202.79	202.79	
04/02/98	05:00	203.13	203.13	148 gpm

**VILLAGE OF HARRIMAN
HARRIMAN, NEW YORK**

OR-7

**Water Level and Pumping Rate Readings During
72-hour Pumping Test on OK-7 Well
from March 30 - April 2, 1998
(continued)**

Date	Time (military)	Depth to water (feet)	Elapsed Time (minutes)	Remarks
04/02/98	06:00	203.52	203.52	148 gpm
	07:00	203.80	203.80	
	08:00	203.81	203.81	
	09:00	203.90	203.90	148 gpm
	10:25	203.84	203.84	Pump Off
	10:27	134.20	13.20	
	10:28	105.20	105.20	
	10:29	96.66	96.66	
	10:30	93.90	43.90	
	10:35	88.40	88.40	
	10:40	86.40	86.40	
	10:45	84.00	84.00	
	10:50	82.40	82.40	
	10:55	81.20	81.20	
	11:25	69.33	69.33	
04/03/98	09:10	28.60	28.60	
04/06/98	10:15	7.91	7.91	

APPENDIX II

**Hydrograph of Monitoring Wells During
72-Hour Pumping Test from March 30 - April 2, 1998**

VILLAGE OF HARRIMAN HARRIMAN, NEW YORK

Hydrograph of Monitoring Well D-2 During 72-Hour Pumping Test
on OR-7 Well from March 30 - April 2, 1998

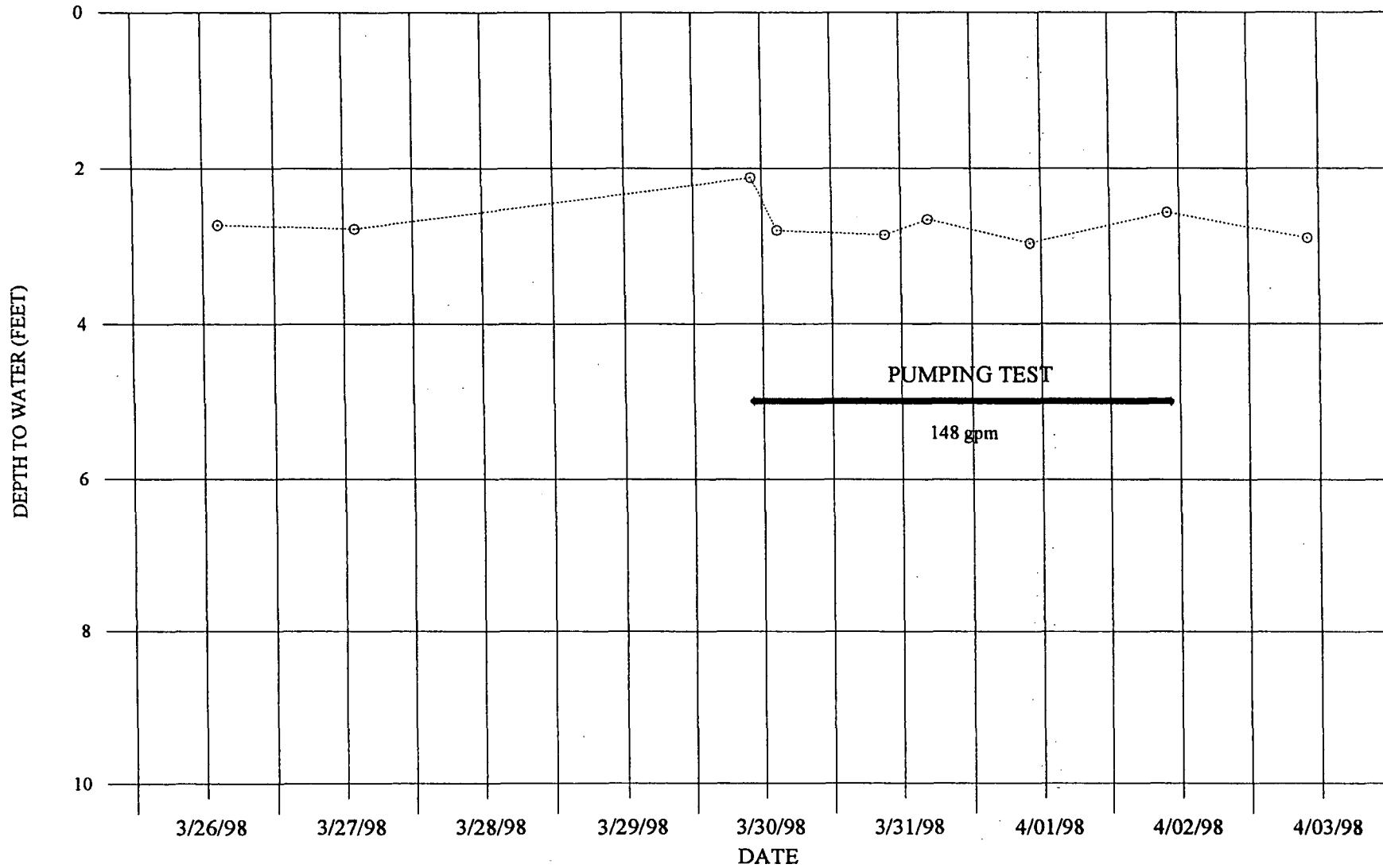

VILLAGE OF HARRIMAN HARRIMAN, NEW YORK

Hydrograph of Monitoring Well S-3 During 72-Hour Pumping Test
on OR-7 Well from March 30 - April 2, 1998

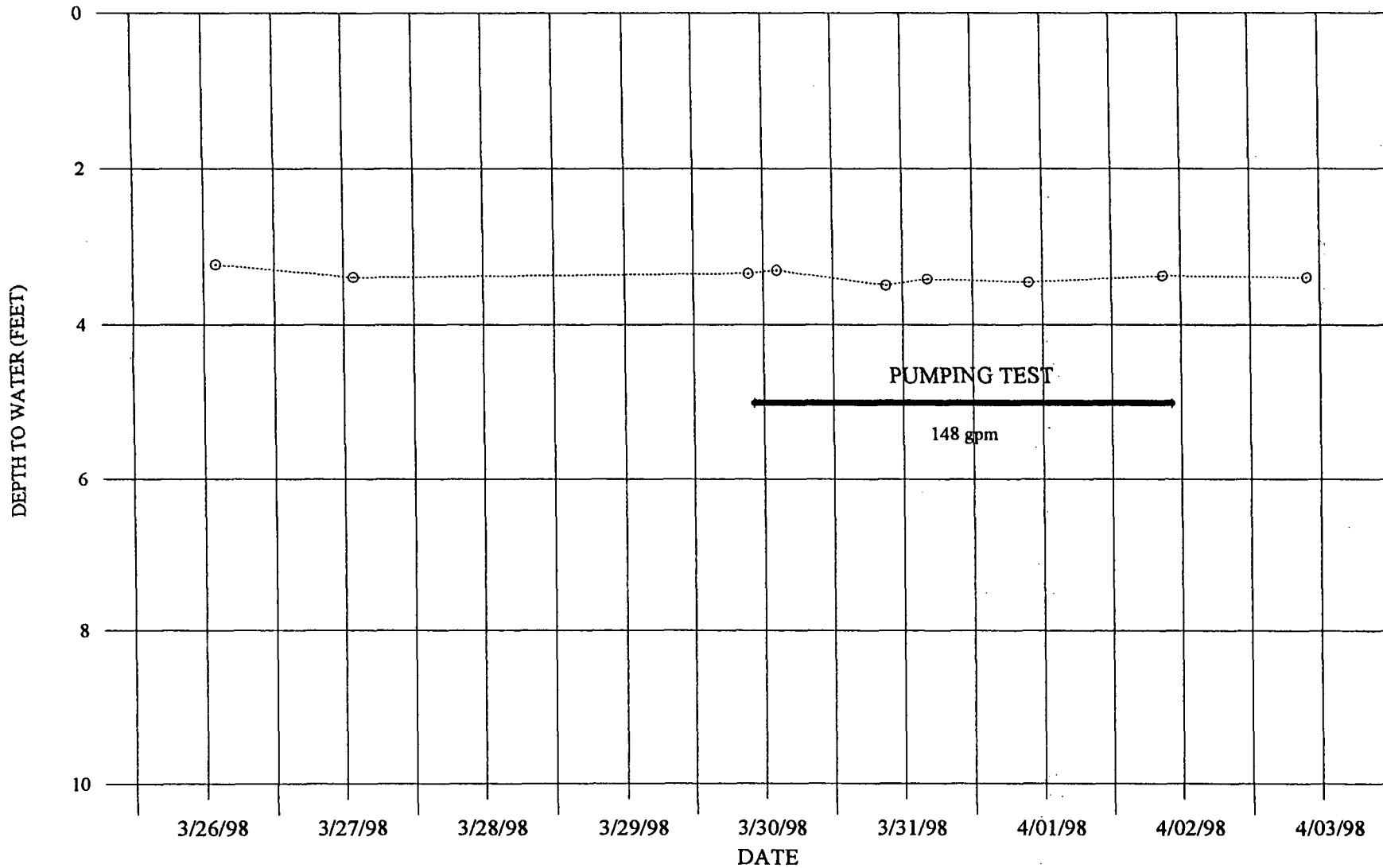

VILLAGE OF HARRIMAN HARRIMAN, NEW YORK

Hydrograph of Monitoring Well D-3 During 72-Hour Pumping Test
on OR-7 Well from March 30 - April 2, 1998

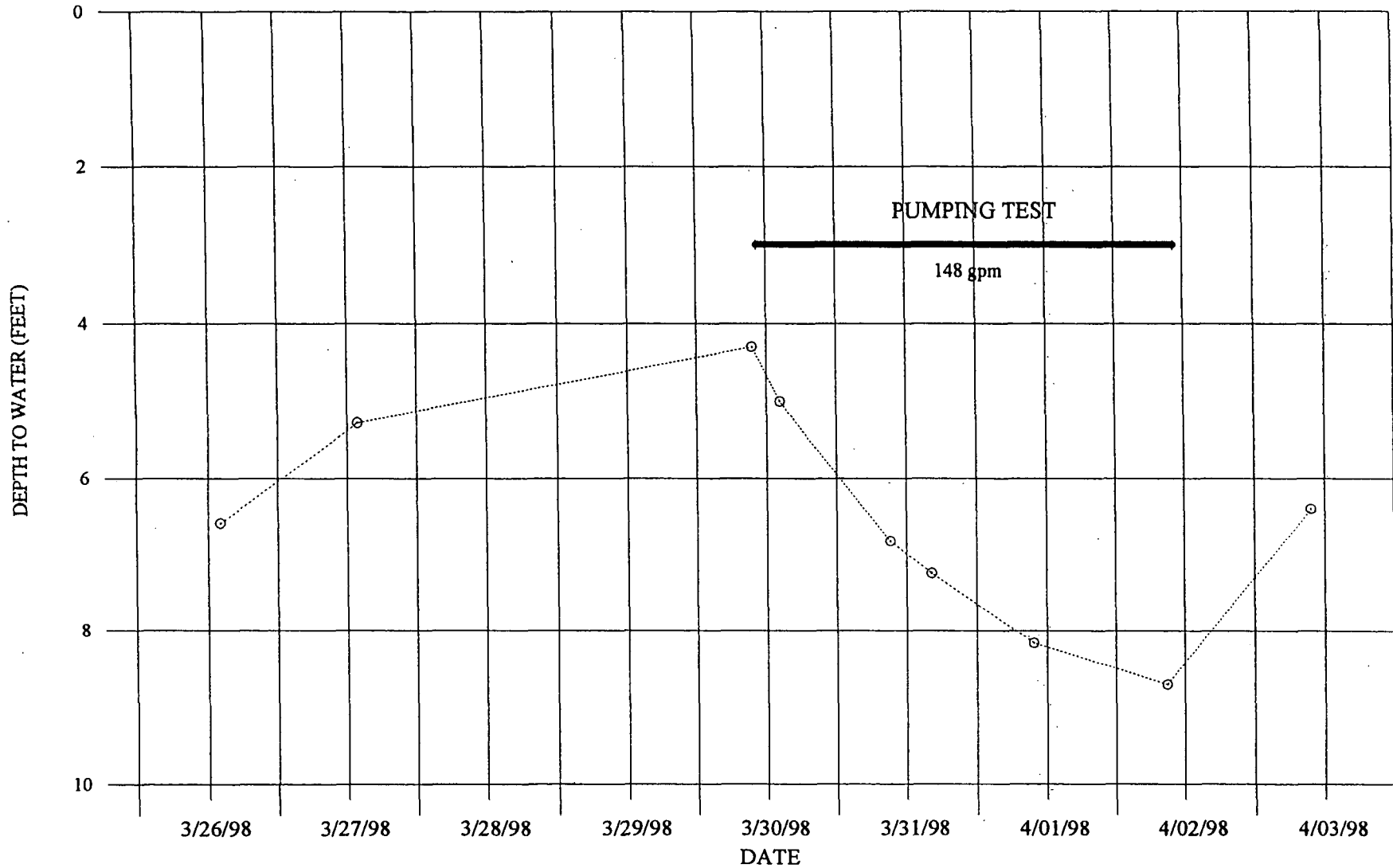

VILLAGE OF HARRIMAN HARRIMAN, NEW YORK

Hydrograph of Monitoring Well S-4 During 72-Hour Pumping Test
on OR-7 Well from March 30 - April 2, 1998

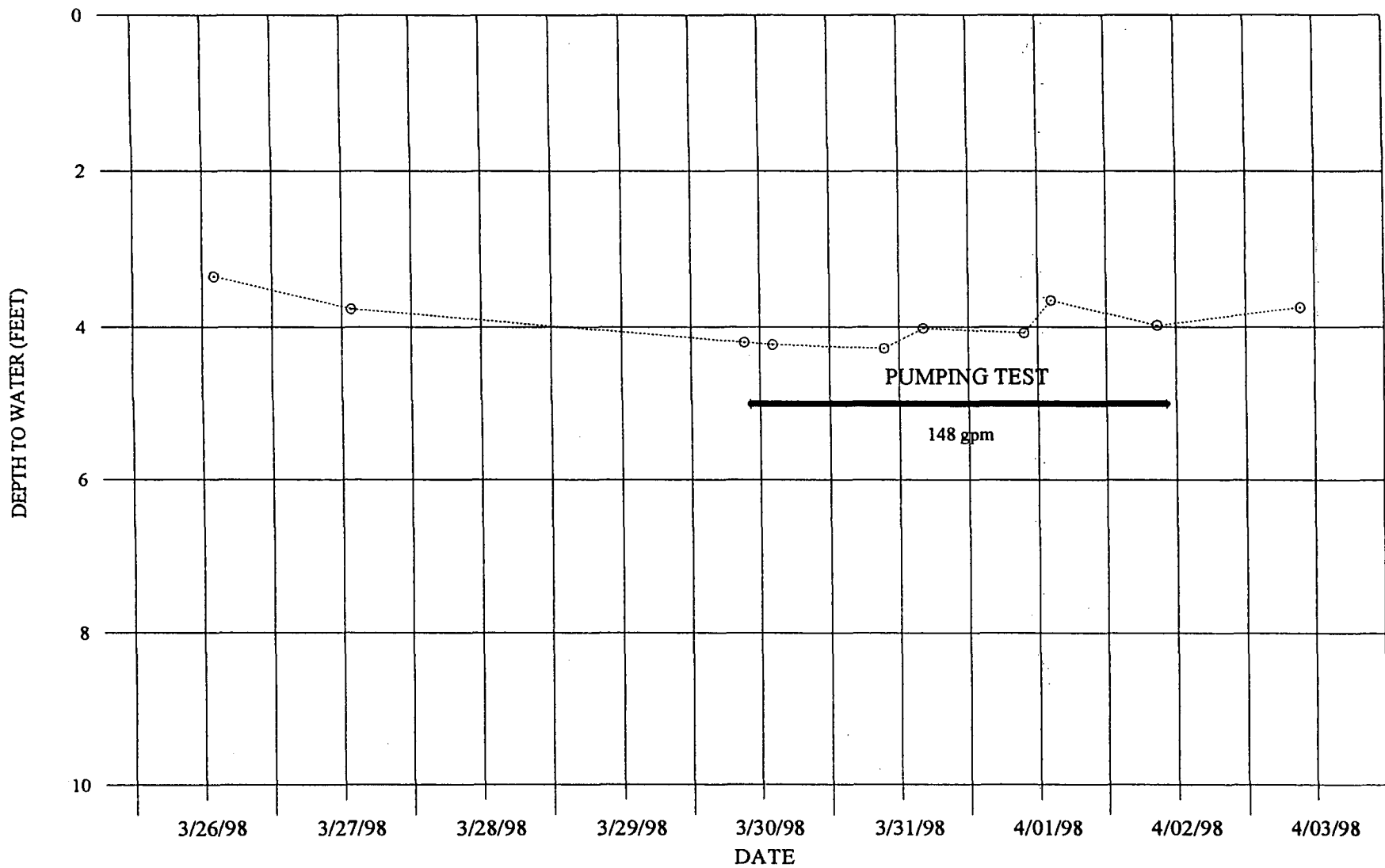

VILLAGE OF HARRIMAN HARRIMAN, NEW YORK

Hydrograph of Monitoring Well D-4 During 72-Hour Pumping Test
on OR-7 Well from March 30 - April 2, 1998

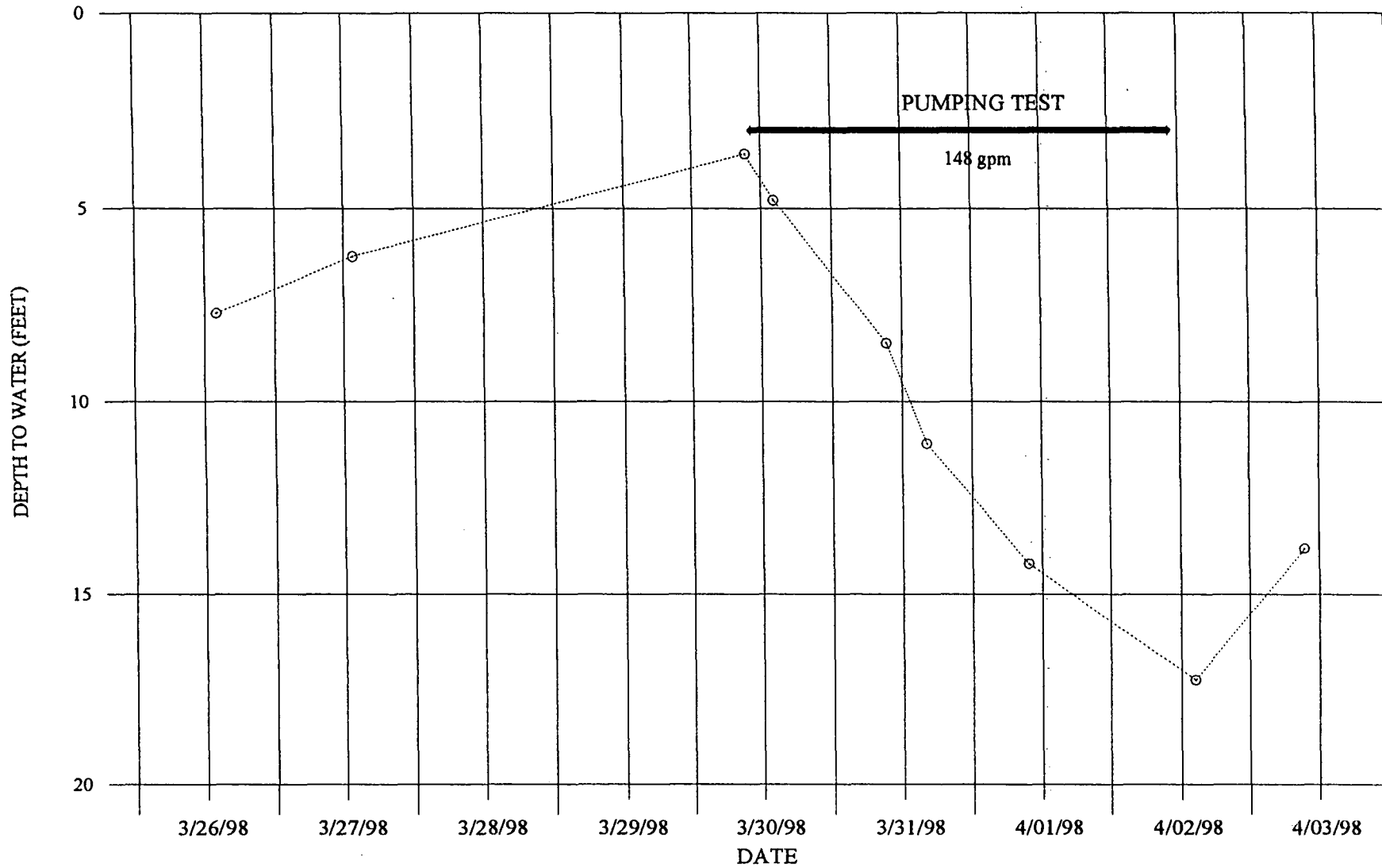

VILLAGE OF HARRIMAN HARRIMAN, NEW YORK

Hydrograph of Monitoring Well MW-23S During 72-Hour Pumping Test
on OR-7 Well from March 30 - April 2, 1998

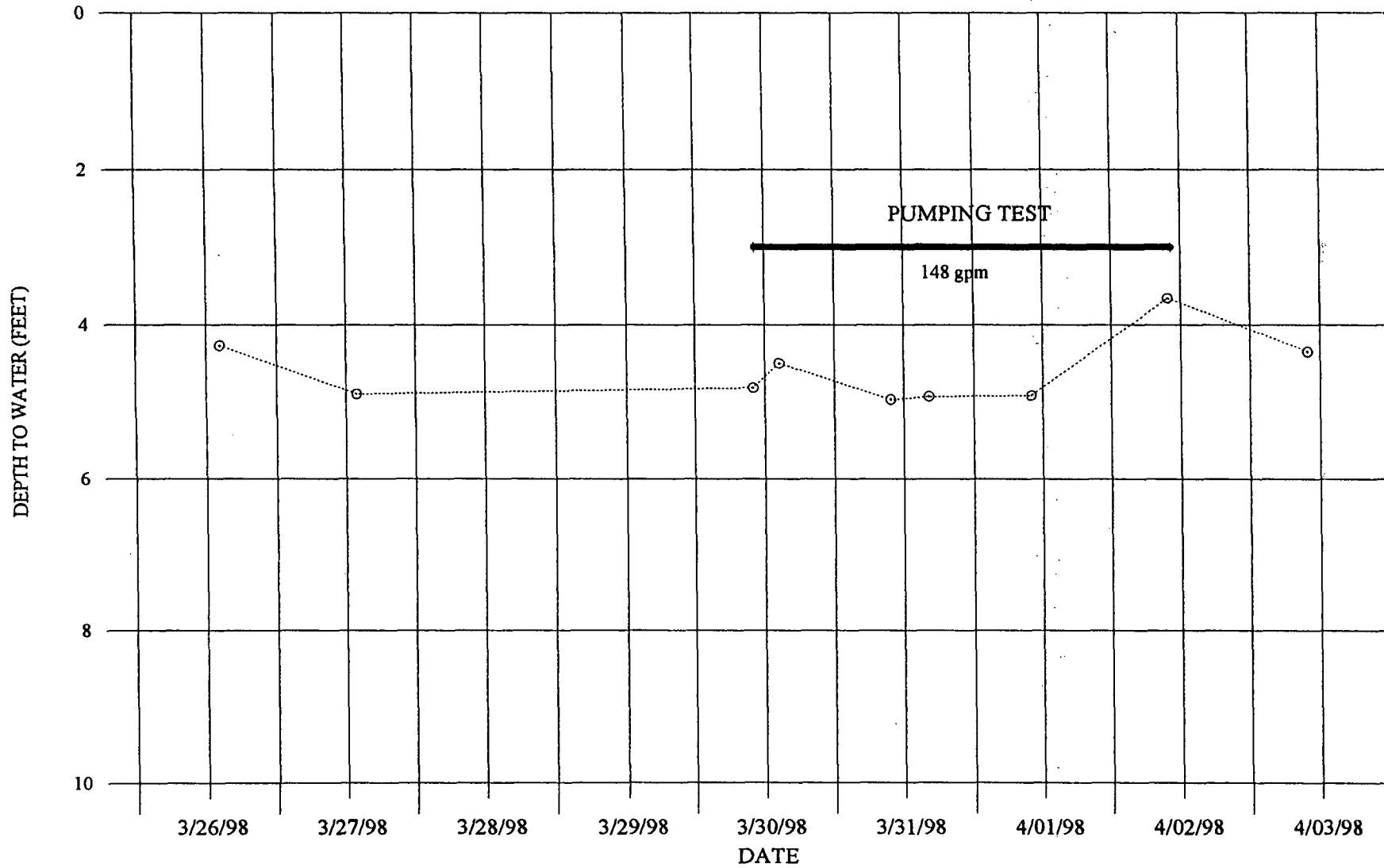

VILLAGE OF HARRIMAN HARRIMAN, NEW YORK

Hydrograph of Monitoring Well MW-23D During 72-Hour Pumping Test
on OR-7 Well from March 30 - April 2, 1998

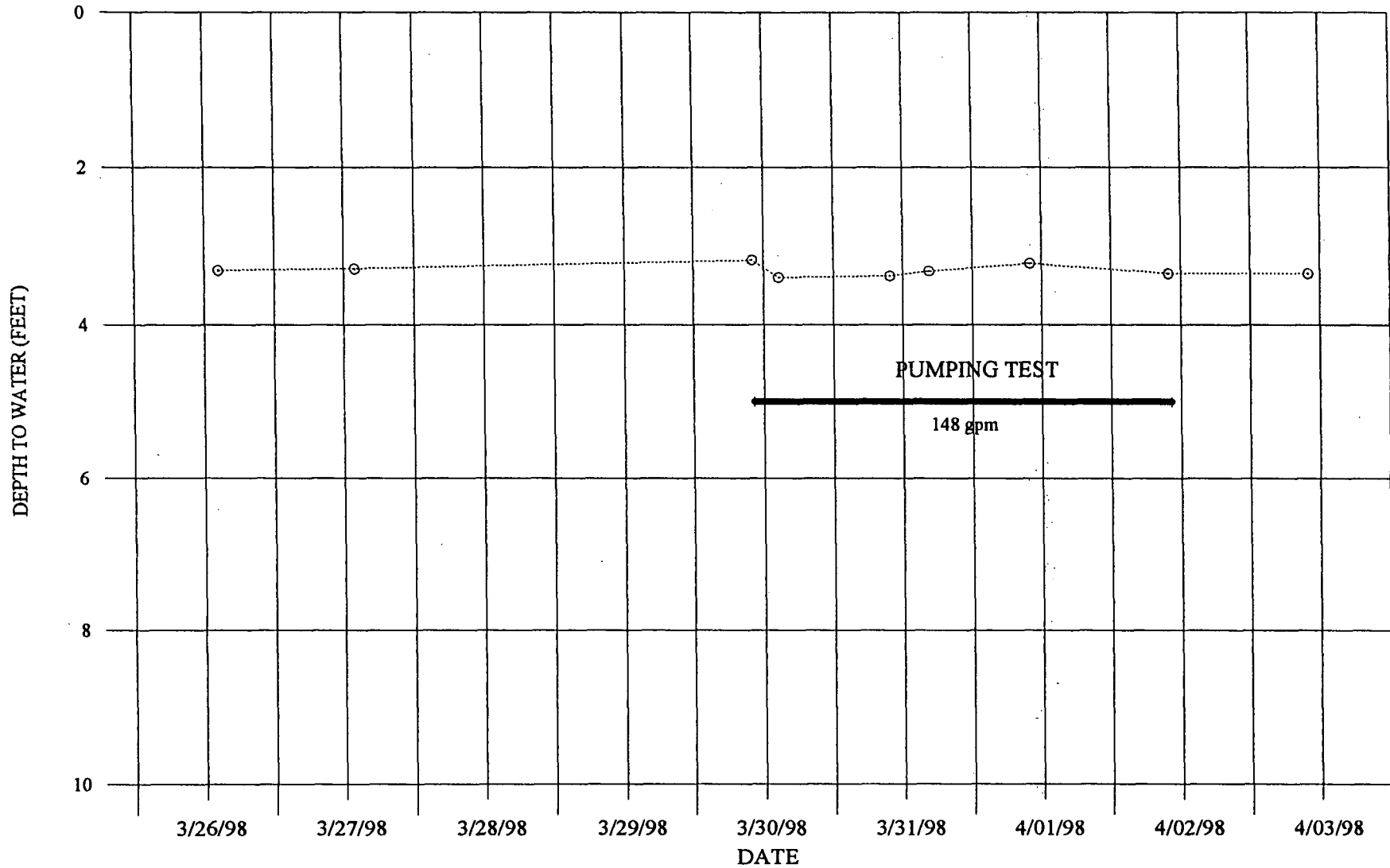

VILLAGE OF HARRIMAN HARRIMAN, NEW YORK

Hydrograph of Monitoring Well MW-6 During 72-Hour Pumping Test
on OR-7 Well from March 30 - April 2, 1998

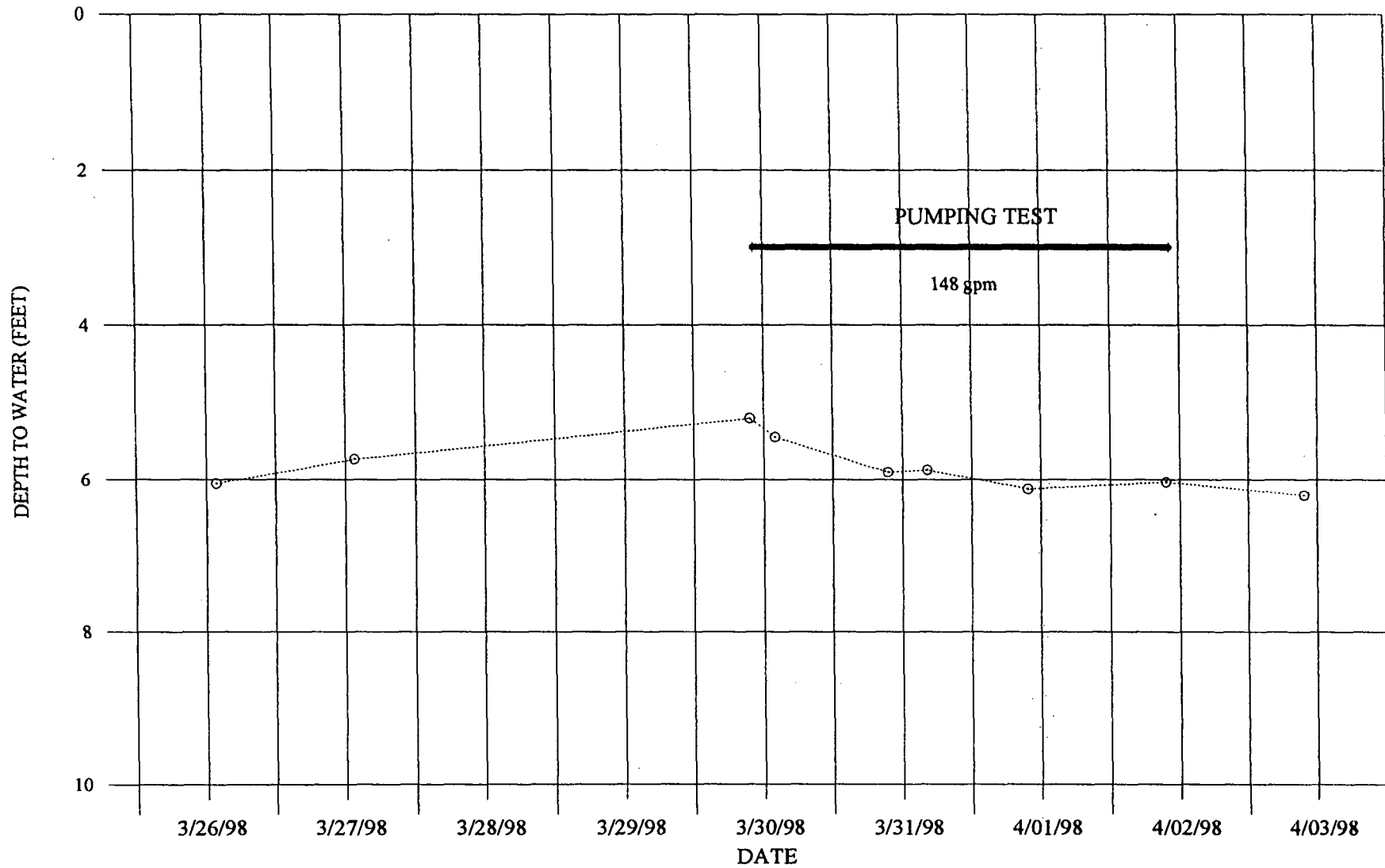

VILLAGE OF HARRIMAN HARRIMAN, NEW YORK

Hydrograph of Monitoring Well MW-7 During 72-Hour Pumping Test
on OR-7 from March 30 - April 2, 1998

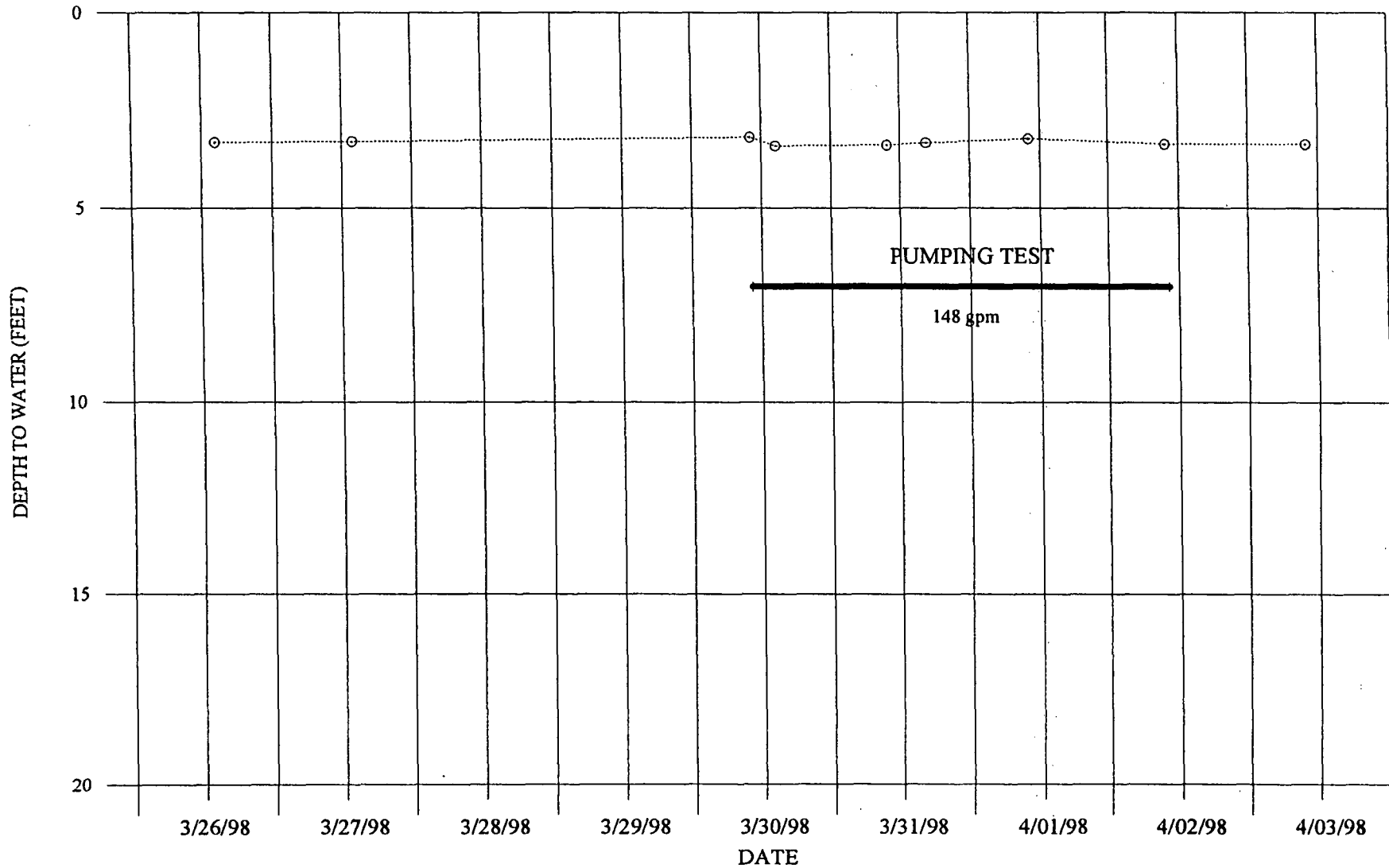

APPENDIX III

Water-Quality Analysis for Well OR-7

OCL

Analytical Services

formerly Orange County Laboratory

ELAP#10510
PADEP#68-545

OCL Analytical Services
35 Goshen Turnpike
Bloomingburg, NY 12721

(914) 733-1557 Fax: (914)733-1944

Monday, April 20, 1998
Page Number : 1

RECEIVED

Harriman Water Dept.
1 Church St.
Harriman NY 10926

APR 27 1998

Client Code : HARRWAT

Leggett & Straub

OCL Sample No : 60566

System Name : Harriman Water Dept.

Date Collected : 4/2/98

Exact Location : OR7

Time Collected :

Submit By : J Karl

Date Received : 4/3/98

Type Descr : 022 SID : Fed ID : 3503531

Analysis	Result	Units	MCL/DL	Method	Lab	Date	By
Benzene	ND	<0.5	5.0	EPA 502.2	11216	4/16/98	RJ
Bromobenzene	ND	<0.5	5.0	EPA 502.2	11216	4/16/98	RJ
Bromochloromethane	ND	<0.5	5.0	EPA 502.2	11216	4/16/98	RJ
Bromomethane	ND	<0.5	5.0	EPA 502.2	11216	4/16/98	RJ
n-Butylbenzene	ND	<0.5	5.0	EPA 502.2	11216	4/16/98	RJ
sec-Butylbenzene	ND	<0.5	5.0	EPA 502.2	11216	4/16/98	RJ
tert-Butylbenzene	ND	<0.5	5.0	EPA 502.2	11216	4/16/98	RJ
Carbon Tetrachloride	ND	<0.5	5.0	EPA 502.2	11216	4/16/98	RJ
Chlorobenzene	ND	<0.5	5.0	EPA 502.2	11216	4/16/98	RJ
Chloroethane	ND	<0.5	5.0	EPA 502.2	11216	4/16/98	RJ
Chloromethane	ND	<0.5	5.0	EPA 502.2	11216	4/16/98	RJ
2-Chlorotoluene	ND	<0.5	5.0	EPA 502.2	11216	4/16/98	RJ
4-Chlorotoluene	ND	<0.5	5.0	EPA 502.2	11216	4/16/98	RJ
Dibromomethane	ND	<0.5	5.0	EPA 502.2	11216	4/16/98	RJ
1,2-Dichlorobenzene	ND	<0.5	5.0	EPA 502.2	11216	4/16/98	RJ
1,3-Dichlorobenzene	ND	<0.5	5.0	EPA 502.2	11216	4/16/98	RJ
1,4-Dichlorobenzene	ND	<0.5	5.0	EPA 502.2	11216	4/16/98	RJ
Dichlorodifluoromethane	ND	<0.5	5.0	EPA 502.2	11216	4/16/98	RJ
1,1-Dichloroethane	ND	<0.5	5.0	EPA 502.2	11216	4/16/98	RJ
1,2-Dichloroethane	ND	<0.5	5.0	EPA 502.2	11216	4/16/98	RJ
1,1-Dichloroethene	ND	<0.5	5.0	EPA 502.2	11216	4/16/98	RJ
cis-1,2-Dichloroethene	ND	<0.5	5.0	EPA 502.2	11216	4/16/98	RJ
trans-1,2-Dichloroethene	ND	<0.5	5.0	EPA 502.2	11216	4/16/98	RJ
1,2-Dichloropropane	ND	<0.5	5.0	EPA 502.2	11216	4/16/98	RJ
1,3-Dichloropropane	ND	<0.5	5.0	EPA 502.2	11216	4/16/98	RJ
2-Dichloropropane	ND	<0.5	5.0	EPA 502.2	11216	4/16/98	RJ
1,1,1-Dichloropropene	ND	<0.5	5.0	EPA 502.2	11216	4/16/98	RJ
cis-1,3-Dichloropropene	ND	<0.5	5.0	EPA 502.2	11216	4/16/98	RJ

GT = greater than
LT = less than
ND = not detected
MCL = maximum contaminant level
DL = detection level

David M. Kennedy - Director

OCL Analytical Services
 35 Goshen Turnpike
 Bloomingburg, NY 12721

ELAP#10510
 PADEP#68-545

OCL
Analytical Services

formerly Orange County Laboratory

(914) 733-1557 Fax: (914)733-1944 # 60566

Monday, April 20, 1998
 Page Number: 2

Analysis	Result	Units	MCL/DL	Method	Lab	Date	By
trans-1,3-Dichloropropene	ND	ug/L	5.0	EPA 502.2	11216	4/16/98	RJ
Ethylbenzene	ND	ug/L	5.0	EPA 502.2	11216	4/16/98	RJ
Hexachlorobutadiene	ND	<0.5	5.0	EPA 502.2	11216	4/16/98	RJ
Isopropylbenzene	ND	<0.5	5.0	EPA 502.2	11216	4/16/98	RJ
p-Isopropyltoluene (p-cymene)	ND	<0.5	5.0	EPA 502.2	11216	4/16/98	RJ
Methylene Chloride	1.1	ug/L	5.0	EPA 502.2	11216	4/16/98	RJ
n-Propylbenzene	ND	<0.5	5.0	EPA 502.2	11216	4/16/98	RJ
Styrene	ND	<0.5	5.0	EPA 502.2	11216	4/16/98	RJ
1,1,1,2-Tetrachloroethane	ND	<0.5	5.0	EPA 502.2	11216	4/16/98	RJ
1,1,2,2-Tetrachloroethane	ND	<0.5	5.0	EPA 502.2	11216	4/16/98	RJ
Tetrachloroethene	ND	<0.5	5.0	EPA 502.2	11216	4/16/98	RJ
Toluene	ND	<0.5	5.0	EPA 502.2	11216	4/16/98	RJ
1,2,3-Trichlorobenzene	ND	<0.5	5.0	EPA 502.2	11216	4/16/98	RJ
1,2,4-Trichlorobenzene	ND	<0.5	5.0	EPA 502.2	11216	4/16/98	RJ
1,1,1-Trichloroethane	ND	<0.5	5.0	EPA 502.2	11216	4/16/98	RJ
1,1,2-Trichloroethane	ND	<0.5	5.0	EPA 502.2	11216	4/16/98	RJ
Trichloroethene	ND	<0.5	5.0	EPA 502.2	11216	4/16/98	RJ
Trichlorofluoromethane	ND	<0.5	5.0	EPA 502.2	11216	4/16/98	RJ
1,2,3-Trichloropropane	ND	<0.5	5.0	EPA 502.2	11216	4/16/98	RJ
1,2,4-Trimethylbenzene	ND	<0.5	5.0	EPA 502.2	11216	4/16/98	RJ
1,3,5-Trimethylbenzene	ND	<0.5	5.0	EPA 502.2	11216	4/16/98	RJ
p/m-Xylene	ND	<0.5	5.0	EPA 502.2	11216	4/16/98	RJ
o-Xylene	ND	<0.5	5.0	EPA 502.2	11216	4/16/98	RJ
Vinyl Chloride	ND	<0.5	2.0	EPA 502.2	11216	4/16/98	RJ

Remarks :

Copies to:

GT = greater than
 LT = less than
 ND = not detected
 MCL = maximum contaminant level
 DL = detection level

David M. Kennedy
 David M. Kennedy - Director

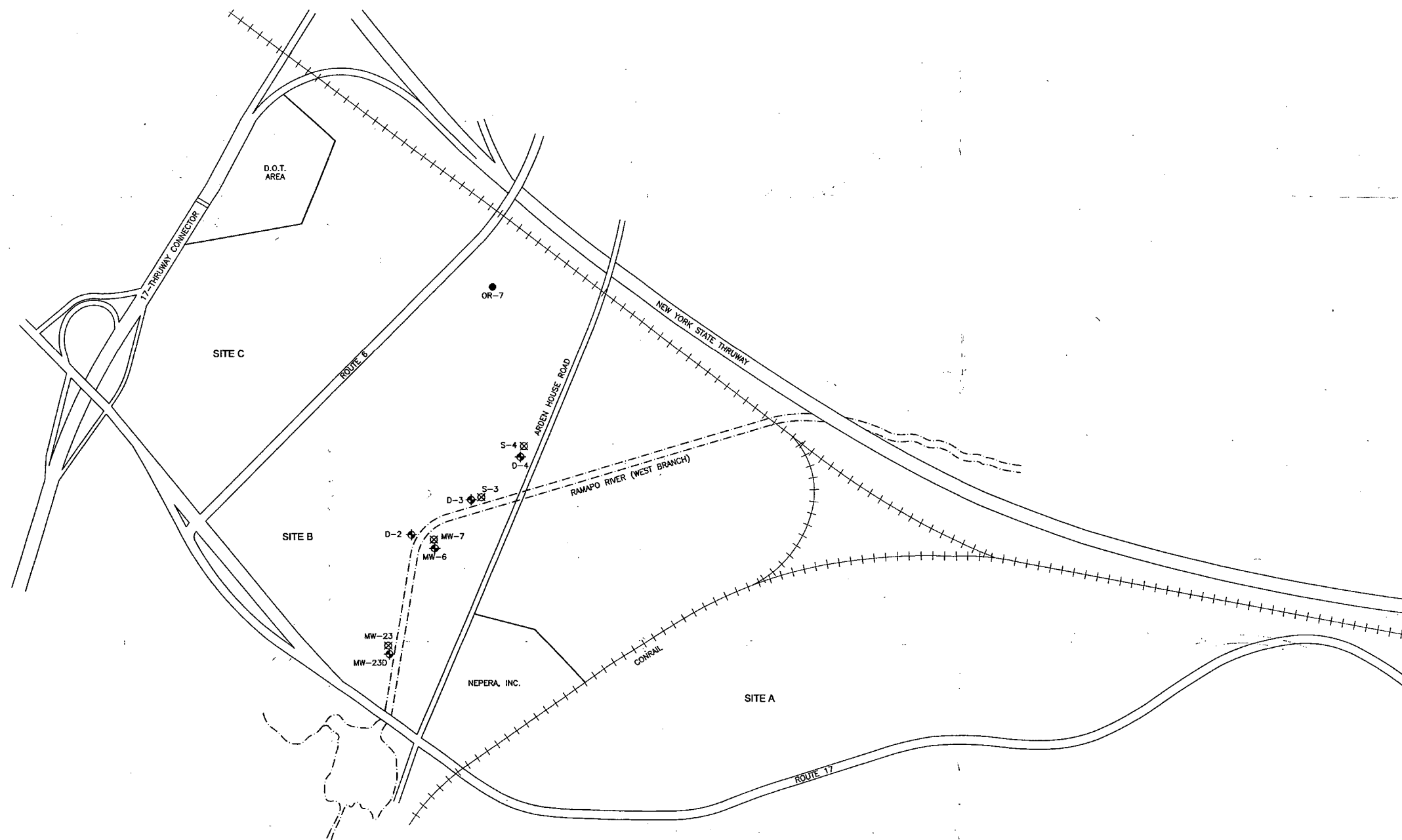
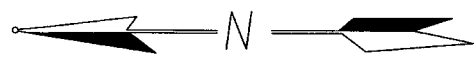

- LEGEND**
- ◆ D-4 BEDROCK MONITORING WELL
 - ⊠ S-4 OVERBURDEN MONITORING WELL
 - MW-7, MW-6, MW-23, MW-23D, OR-7 PRODUCTION WELL

**VILLAGE OF HARRIMAN
HARRIMAN, NEW YORK**

PRODUCTION AND MONITORING WELL LOCATION MAP

DATE	REVISED	PREPARED BY:
		LEGGETTE, BRASHEARS & GRAHAM, INC.
		Professional Ground-Water and Environmental Engineering Services
		126 Monroe Turnpike
		Trumbull CT 06611
		(203) 452-3100



DRAWN:	TLC	CHECKED:	TPC	DATE:	5/5/98	PLATE:	1
--------	-----	----------	-----	-------	--------	--------	---



Appendix G

Proposed Groundwater Monitoring
Program

Appendix G is a Stand Alone Document