



Radon Mitigation Fans

All RadonAway fans are specifically designed for radon mitigation. RP Series Fans provide superb performance, run ultra-quiet and are attractive. They are ideal for most sub-slab radon mitigation systems.

Features:

- ◆ Five-year hassle-free warranty
- ◆ Quiet and attractive
- ◆ Thermally protected
- ◆ Motorized impeller
- ◆ ETL Listed - for indoor or outdoor use
- ◆ Meets all electrical code requirements
- ◆ Rated for commercial and residential use



Model	Watts	Max. Pressure "WC	Typical CFM vs. Static Pressure WC							
			0"	.5"	1.0"	1.5"	2.0"	A"	B"	C"
RP140	14-20	0.8	134	68	-	-	-	9.7	7.9	4
RP145	37-71	2.1	173	132	94	55	11	9.7	7.9	4
RP260	52-72	1.8	275	180	105	20	-	11.8	9.9	6
RP265	86-140	2.5	327	260	207	139	57	11.8	9.9	6
RP380	103-156	2.3	510	393	268	165	35	13.41	10.53	8

Choice of model is dependent on building characteristics including sub-slab materials and should be made by a radon professional.

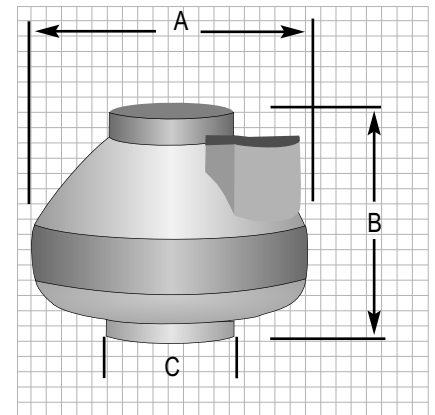

For Further Information Contact:

RP Series Installation Instructions

By

RadonAway™

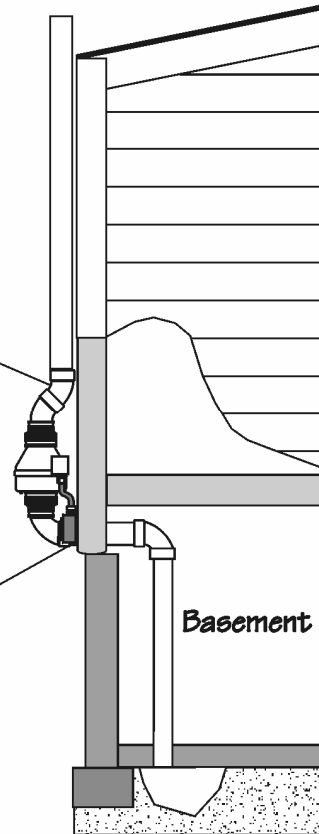
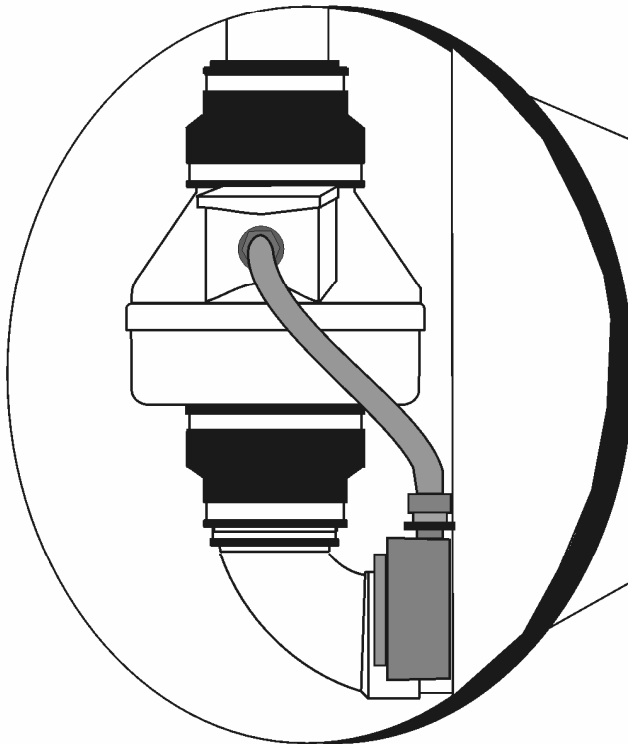

Spruce Environmental Technologies, Inc.
Ward Hill, MA P/N IN020 Rev H



Series Fan Installation Instructions

Please Read and Save These Instructions.

**DO NOT CONNECT POWER SUPPLY UNTIL FAN IS COMPLETELY INSTALLED.
MAKE SURE ELECTRICAL SERVICE TO FAN IS LOCKED IN "OFF" POSITION.
DISCONNECT POWER BEFORE SERVICING FAN.**

1. **WARNING!** Do not use fan in hazardous environments where fan electrical system could provide ignition to combustible or flammable materials.
2. **WARNING!** Do not use fan to pump explosive or corrosive gases.
3. **WARNING!** Check voltage at the fan to insure it corresponds with nameplate.
4. **WARNING!** Normal operation of this device may affect the combustion airflow needed for safe operation of fuel burning equipment. Check for possible backdraft conditions on all combustion devices after installation.
5. **NOTICE!** There are no user serviceable parts located inside the fan unit.
Do NOT attempt to open. Return unit to the factory for service.
6. All wiring must be performed in accordance with the National Fire Protection Association's (NFPA) "National Electrical Code, Standard #70"-current edition for all commercial and industrial work, and state and local building codes. All wiring must be performed by a qualified and licensed electrician
7. **WARNING!** Do not leave fan unit installed on system piping without electrical power for more than 48 hours. Fan failure could result from this non-operational storage.

DynaVac RP Series Fan Wiring Diagram

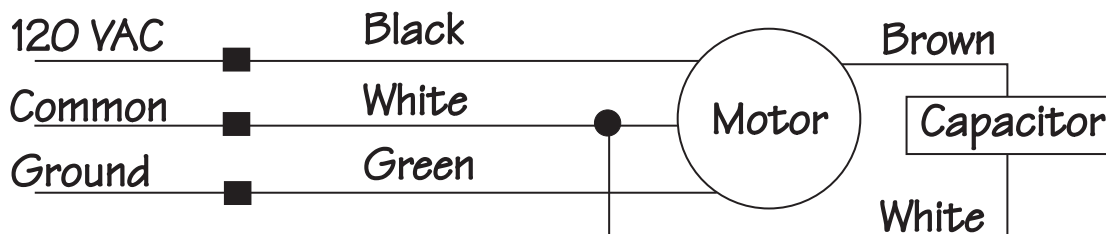

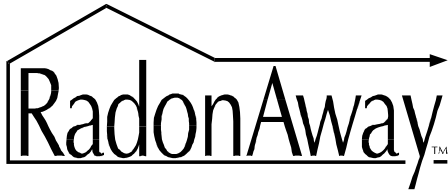
**DynaVac - RP Series****RP140 p/n 23029-1****RP145 p/n 23030-1****RP155 p/n 23031-1****RP260 p/n 23032-1****RP265 p/n 23033-1****RP380 p/n 28208****1.0 SYSTEM DESIGN CONSIDERATIONS****1.1 INTRODUCTION**

The DynaVac RP Series Radon Fans are intended for use by trained, professional Radon mitigators. The purpose of this instruction is to provide additional guidance for the most effective use of a DynaVac Fan. This instruction should be considered as a supplement to EPA standard practices, state and local building codes and state regulations. In the event of a conflict, those codes, practices and regulations take precedence over this instruction.

1.2 ENVIRONMENTALS

The RP Series Fans are designed to perform year-round in all but the harshest climates without additional concern for temperature or weather. For installations in an area of severe cold weather, please contact RadonAway for assistance. When not in operation, the fan should be stored in an area where the temperature is never less than 32 degrees F. or more than 100 degrees F.

1.3 ACOUSTICS

The RP Series Fan, when installed properly, operates with little or no noticeable noise to the building occupants. The velocity of the outgoing air should be considered in the overall system design. In some cases the "rushing" sound of the outlet air may be disturbing. In these instances, the use of a RadonAway Exhaust Muffler is recommended.

1.4 GROUND WATER

In the event that a temporary high water table results in water at or above slab level, water may be drawn into the riser pipes thus blocking air flow to the RP Series Fan. The lack of cooling air may result in the fan cycling on and off as the internal temperature rises above the thermal cutoff and falls upon shutoff. Should this condition arise, it is recommended that the fan be turned off until the water recedes allowing for return to normal operation.

1.5 SLAB COVERAGE

The RP Series Fan can provide coverage up to 2000+ sq. ft. per slab penetration. This will primarily depend on the sub-slab material in any particular installation. In general, the tighter the material, the smaller the area covered per penetration. Appropriate selection of the RP Series Fan best suited for the sub-slab material can improve the slab coverage. The RP140/145/155 are best suited for general purpose use. The RP260 can be used where additional airflow is required and the RP265/380 is best suited for large slab, high airflow applications. Additional suction points can be added as required. It is recommended that a small pit (5 to 10 gallons in size) be created below the slab at each suction hole.

1.6 CONDENSATION & DRAINAGE

Condensation is formed in the piping of a mitigation system when the air in the piping is chilled below its dew point. This can occur at points where the system piping goes through unheated space such as an attic, garage or outside. The system design must provide a means for water to drain back to a slab hole to remove the condensation. The RP Series Fan **MUST** be mounted vertically plumb and level, with the outlet pointing up for proper drainage through the fan. Avoid mounting the fan in any orientation that will allow water to accumulate inside the fan housing. The RP Series Fans are **NOT** suitable for underground burial.

For RP Series Fan piping, the following table provides the minimum recommended pipe diameter and pitch under several system conditions.

Pipe Dia.	Minimum Rise per Ft of Run*				
	@25 CFM	@50 CFM	@100 CFM	@200 CFM	@300 CFM
6"	-	3/16	1/4	3/8	3/4
4"	1/8	1/4	3/8	2 3/8	-
3"	1/4	3/8	1 1/2	-	-



*Typical RP1xx/2xx Series Fan operational flow rate is 25 - 90 CFM on 3" and 4" pipe.
(For more precision, determine flow rate by measuring Static Pressure, in WC, and correlate pressure to flow in the performance chart in the addendum.)

Under some circumstances in an outdoor installation a condensate bypass should be installed in the outlet ducting as shown. This may be particularly true in cold climate installations which require long lengths of outlet ducting or where the outlet ducting is likely to produce large amounts of condensation because of high soil moisture or outlet duct material. Schedule 20 piping and other thin-walled plastic ducting and Aluminum downspout will normally produce much more condensation than Schedule 40 piping.

The bypass is constructed with a 45 degree Wye fitting at the bottom of the outlet stack. The bottom of the Wye is capped and fitted with a tube that connects to the inlet piping or other drain. The condensation produced in the outlet stack is collected in the Wye fitting and drained through the bypass tube. The bypass tubing may be insulated to prevent freezing.

1.7 "SYSTEM ON" INDICATOR

A properly designed system should incorporate a "System On" Indicator for affirmation of system operation. A manometer, such as a U-Tube, or a vacuum alarm is recommended for this purpose.

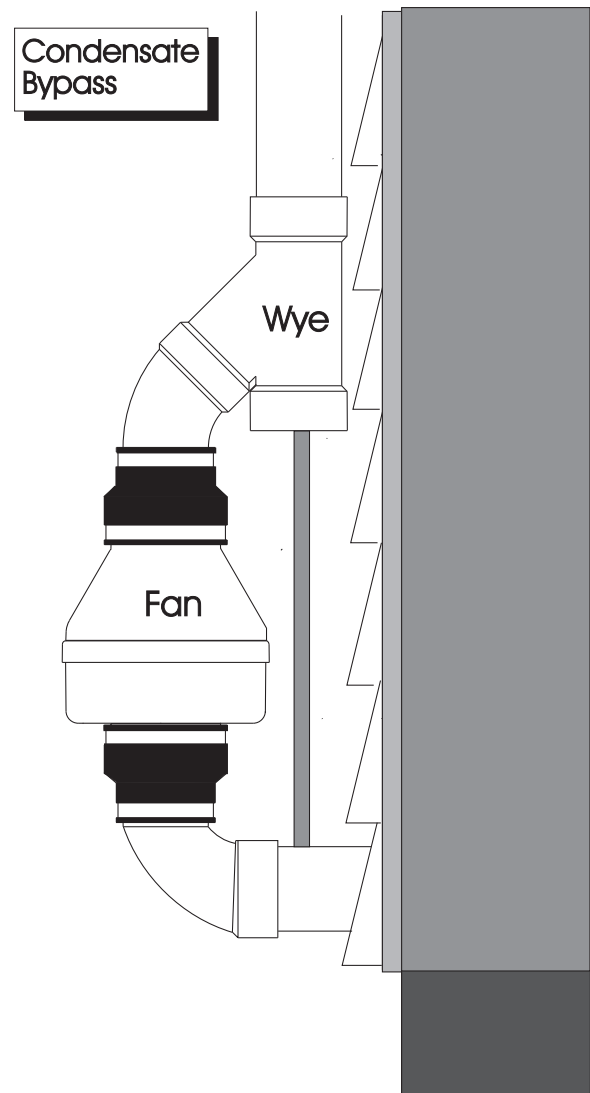

1.8 ELECTRICAL WIRING

The RP Series Fans operate on standard 120V 60 Hz. AC. All wiring must be performed in accordance with the National Fire Protection Association's (NFPA) National Electrical Code, Standard #70"-current edition for all commercial and industrial work, and state and local building codes. All wiring must be performed by a qualified and licensed electrician. Outdoor installations require the use of a U.L. listed watertight conduit. Ensure that all exterior electrical boxes are outdoor rated and properly caulked to prevent water penetration into the box. A means, such as a weep hole, is recommended to drain the box.

1.9 SPEED CONTROLS

The RP Series Fans are rated for use with electronic speed controls ,however , they are generally not recommended.

2.0 INSTALLATION

The RP Series Fan can be mounted indoors or outdoors. (It is suggested that EPA recommendations be followed in choosing the fan location.) The RP Series Fan may be mounted directly on the system piping or fastened to a supporting structure by means of optional mounting bracket.

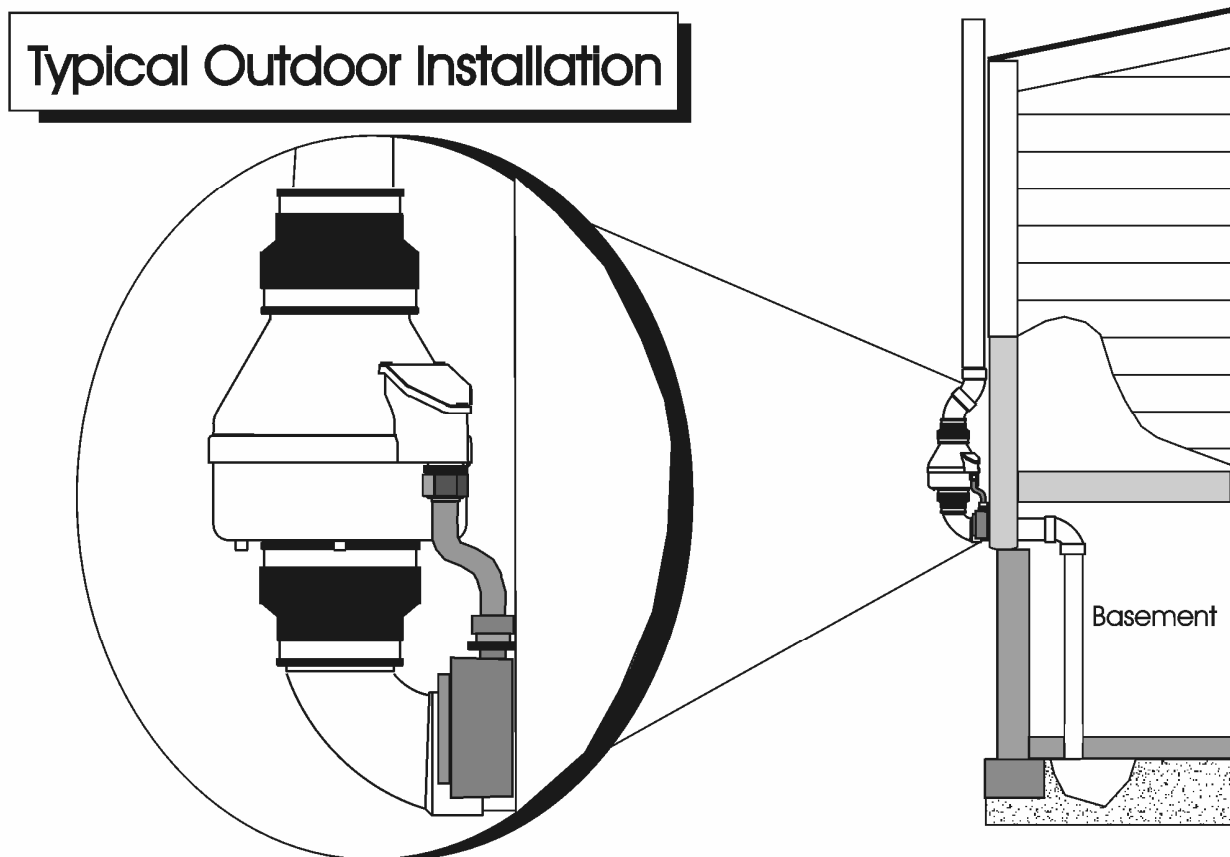

2.1 MOUNTING

Mount the RP Series Fan vertically with outlet up. Insure the unit is plumb and level. When mounting directly on the system piping assure that the fan does not contact any building surface to avoid vibration noise.

2.2 MOUNTING BRACKET (optional)

The RP Series fan may be optionally secured with the RadonAway P/N 25007-2 (25033 for RP385) mounting bracket. Foam or rubber grommets may also be used between the bracket and mounting surface for vibration isolation.

2.3 SYSTEM PIPING

Complete piping run, using flexible couplings as means of disconnect for servicing the unit and vibration isolation.

2.4 ELECTRICAL CONNECTION

Connect wiring with wire nuts provided, observing proper connections:

Fan Wire	Connection
Green	Ground
Black	AC Hot
White	AC Common

2.5 VENT MUFFLER (optional)

Install the muffler assembly in the selected location in the outlet ducting. Solvent weld all connections. The muffler is normally installed at the end of the vent pipe.

2.6 OPERATION CHECKS

- _____ **Verify** all connections are tight and **leak-free**.
- _____ **Insure** the RP Series Fan and all ducting is secure and vibration-free.
- _____ **Verify** system vacuum pressure with manometer. **Insure** vacuum pressure is **less than** maximum recommended operating pressure
(Based on sea-level operation, at higher altitudes reduce by about 4% per 1000 Feet.)
(Further reduce Maximum Operating Pressure by 10% for High Temperature environments)
See Product Specifications. If this is exceeded, increase the number of suction points.
- _____ **Verify Radon levels by testing to EPA protocol.**

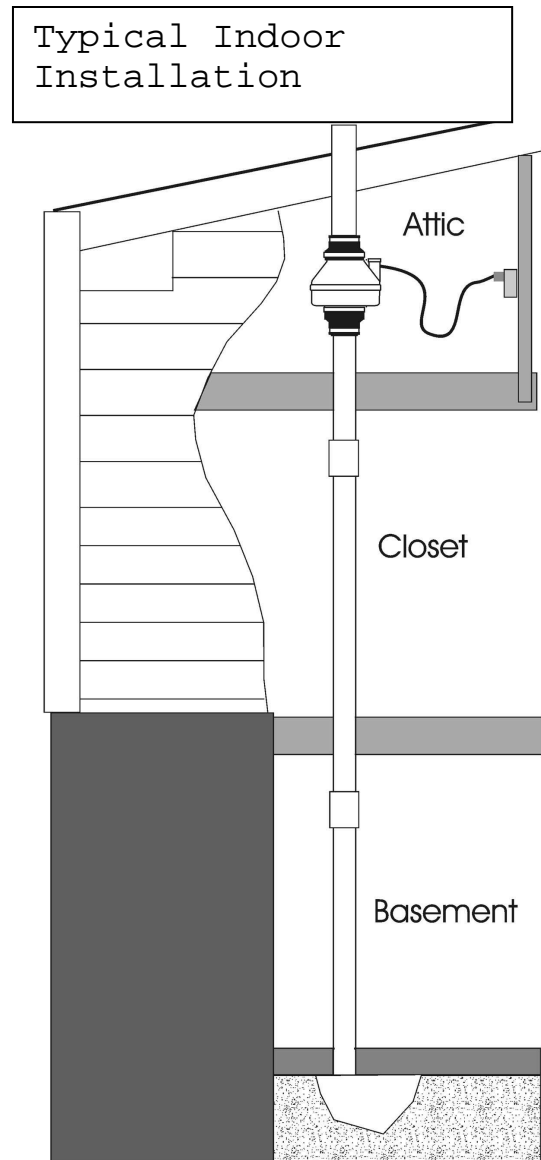

RP SERIES PRODUCT SPECIFICATIONS

The following chart shows fan performance for the RP Series Fan:

Typical CFM Vs Static Pressure "WC									
	0"	.25"	.5"	.75"	1.0"	1.25"	1.5"	1.75"	2.0"
RP140	134	101	68	10	-	-	-	-	-
RP145	173	152	132	115	94	73	55	37	-
RP155	185	161	137	115	94	73	55	37	-
RP260	275	225	180	140	105	70	20	-	-
RP265	327	302	260	230	207	176	139	101	57
RP380*	420	375	330	260	220	170	130	70	30

* Tested with 6" inlet and discharge pipe.

Power Consumption 120 VAC, 60Hz 1.5 Amp Maximum			Maximum Recommended Operating Pressure* (Sea Level Operation)**	
RP140	14 - 20	watts	RP140	0.8" W.C.
RP145	37 - 71	watts	RP145	1.7" W.C.
RP155	37 - 75	watts	RP155	1.7" W.C.
RP260	52 - 72	watts	RP260	1.5" W.C.
RP265	86 - 140	watts	RP265	2.2" W.C.
RP380	95 - 152	watts	RP380	2.0" W.C.

*Reduce by 10% for High Temperature Operation

**Reduce by 4% per 1000 feet of altitude

	Size	Weight	Inlet/Outlet
RP140	8.5H" x 9.7" Dia.	5.5 lbs.	4.5" OD (4.0" PVC Sched 40 size compatible)
RP145	8.5H" x 9.7" Dia.	5.5 lbs.	4.5" OD (4.0" PVC Sched 40 size compatible)
RP155	8.5H" x 9.7" Dia.	5.5 lbs.	5.0" OD
RP260	8.6H" x 11.75" Dia.	5.5 lbs.	6.0" OD
RP265	8.6H" x 11.75" Dia.	6.5 lbs.	6.0" OD
RP380	10.53H" x 13.41" Dia.	11.5 lbs.	8.0" OD

Recommended ducting: 3" or 4" RP1xx/2xx, 6" RP380, Schedule 20/40 PVC Pipe

Mounting: Mount on the duct pipe or with optional mounting bracket.

Storage temperature range: 32 - 100 degrees F.

Normal operating temperature range: -20 - 120 degrees F.

Maximum inlet air temperature: 80 degrees F.

Continuous Duty

Class B Insulation

Thermally protected

3000 RPM

Rated for Indoor or Outdoor Use



IMPORTANT INSTRUCTIONS TO INSTALLER

Inspect the GP/XP/XR/RP Series Fan for shipping damage within 15 days of receipt. Notify **RadonAway of any damages immediately**. Radonaway is not responsible for damages incurred during shipping. However, for your benefit, Radonaway does insure shipments.

There are no user serviceable parts inside the fan. **Do not attempt to open**. Return unit to factory for service.

Install the GP/XP/XR/RP Series Fan in accordance with all EPA standard practices, and state and local building codes and state regulations.

WARRANTY

Subject to any applicable consumer protection legislation, RadonAway warrants that the GPX01/XP/XR/RP Series Fan (the "Fan") will be free from defects in materials and workmanship for a period of 90 days from the date of purchase (the "Warranty Term").

RadonAway will replace any Fan which fails due to defects in materials or workmanship. The Fan must be returned (at Owner's cost) to the RadonAway factory. Any Fan returned to the factory will be discarded unless the Owner provides specific instructions along with the Fan when it is returned regardless of whether or not the Fan is actually replaced under this warranty. Proof of purchase must be supplied upon request for service under this Warranty.

This Warranty is contingent on installation of the Fan in accordance with the instructions provided. This Warranty does not apply where any repairs or alterations have been made or attempted by others, or if the unit has been abused or misused. Warranty does not cover damage in shipment unless the damage is due to the negligence of RadonAway.

5 YEAR EXTENDED WARRANTY WITH PROFESSIONAL INSTALLATION.

RadonAway will extend the Warranty Term of the fan to 5 years from date of manufacture if the Fan is installed in a professionally designed and professionally installed radon system or installed as a replacement fan in a professionally designed and professionally installed radon system. Proof of purchase and/or proof of professional installation may be required for service under this warranty. Outside the Continental United States and Canada the extended Warranty Term is limited to one (1) year from the date of manufacture.

RadonAway is not responsible for installation, removal or delivery costs associated with this Warranty.

EXCEPT AS STATED ABOVE, THE GPx01/XP/XR/RP SERIES FANS ARE PROVIDED WITHOUT WARRANTY OF ANY KIND, EITHER EXPRESS OR IMPLIED, INCLUDING, WITHOUT LIMITATION, IMPLIED WARRANTIES OF MERCHANTABILITY AND FITNESS FOR A PARTICULAR PURPOSE.

IN NO EVENT SHALL RADONAWAY BE LIABLE FOR ANY DIRECT, INDIRECT, SPECIAL, INCIDENTAL, OR CONSEQUENTIAL DAMAGES ARISING OUT OF, OR RELATING TO, THE FAN OR THE PERFORMANCE THEREOF. RADONAWAY'S AGGREGATE LIABILITY HEREUNDER SHALL NOT IN ANY EVENT EXCEED THE AMOUNT OF THE PURCHASE PRICE OF SAID PRODUCT. THE SOLE AND EXCLUSIVE REMEDY UNDER THIS WARRANTY SHALL BE THE REPAIR OR REPLACEMENT OF THE PRODUCT, TO THE EXTENT THE SAME DOES NOT MEET WITH RADONAWAY'S WARRANTY AS PROVIDED ABOVE.

For service under this Warranty, contact RadonAway for a Return Material Authorization (RMA) number and shipping information. No returns can be accepted without an RMA. If factory return is required, the customer assumes all shipping cost to and from factory.

RadonAway
3 Saber Way
Ward Hill, MA 01835
TEL. (978) 521-3703
FAX (978) 521-3964

Record the following information for your records:

Serial No. _____
Purchase Date _____