

**Closure Plan for the
Witmer Road Landfill
Niagara Falls, New York**

RECEIVED
MAY 18 2000
NYSDEC-REG. 9
FOIL
REL UNREL

Prepared for

The BOC Group
100 Mountain Avenue
Murray Hill, New Jersey 07974

Prepared by

EA Engineering, P.C. and Its Affiliate
EA Engineering, Science, and Technology
3 Washington Center
Newburgh, New York 12550
(914) 565-8100

April 2000
Revision: FINAL
Project No. 12040.65

Closure Plan for the Witmer Road Landfill Niagara Falls, New York

Prepared for

The BOC Group
100 Mountain Avenue
Murray Hill, New Jersey 07974

RECEIVED
MAY 18 2000
NYSDEC - REG. 9
REL - UNREL

Prepared by

EA Engineering, P.C. and Its Affiliate
EA Engineering, Science, and Technology
3 Washington Center
Newburgh, New York



David S. Santoro, P.E., L.S.
President, EA Engineering, P.C.

20 April 2000

Date

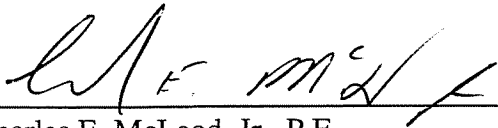

Charles E. McLeod, Jr., P.E.
Project Manager/Program Manager
EA Engineering, Science, and Technology

20 April 2000

Date

April 2000
Revision: FINAL
Project No. 12040.65

CONTENTS

	<u>Page</u>
LIST OF FIGURES	
1. INTRODUCTION.....	1
1.1 Statement of Purpose.....	1
1.2 Organization.....	1
1.3 Regulatory Guidance.....	1
2. SITE INFORMATION.....	3
2.1 Site Setting	3
2.1.1 Site Access and Easement Agreements.....	3
2.2 Site History.....	4
2.3 Environmental Status	4
2.3.1 Pre-Design Investigations	5
2.3.1.1 Leachate Survey.....	5
2.3.1.2 Ecological Vector Survey	5
2.4 Extent of Waste Fill Materials	6
2.4.1 Consolidation of Waste Materials	7
3. LANDFILL CAP DESIGN.....	8
3.1 Requested Variances to Final Cover System	8
3.2 Landfill Cap Components	8
3.2.1 Bedding Layer	8
3.2.2 Low Permeability Layer.....	9
3.2.3 Drainage Layer.....	9
3.2.4 Barrier Protection Layer.....	10
3.2.5 Topsoil Layer	10
3.3 Eastern Property Line.....	10
3.4 Stormwater Management	11
3.5 Leachate Collection System.....	11
3.6 Site Grading.....	11

	<u>Page</u>
4. LANDFILL CAP CONSTRUCTION/OPERATION AND MAINTENANCE.....	12
4.1 Construction Schedule.....	12
4.1.1 Required Air Monitoring During Construction Activities	12
4.2 Closure Report and Construction Certification	13
4.3 Operation, Monitoring, and Maintenance	13
4.3.1 Landfill Maintenance	13
APPENDIX A: POST-CLOSURE MONITORING AND FACILITY MAINTENANCE PLAN	
APPENDIX B: CONSTRUCTION QUALITY ASSURANCE AND CONSTRUCTION QUALITY CONTROL PLAN	
APPENDIX C: DESIGN SPECIFICATIONS	
APPENDIX D: DESIGN CALCULATIONS	

LIST OF FIGURES

<u>Number</u>	<u>Title</u>
1	Site location map, Witmer Road Landfill Design-Build Site Closure, Niagara Falls, New York.
2	Vanadium site, Witmer Road Landfill Design-Build Site Closure, Niagara Falls, New York.
3	Approximate seep locations, Witmer Road Landfill Design-Build Site Closure, Niagara Falls, New York.
4	Closure schedule, Witmer Road Landfill Design-Build Site Closure, Niagara Falls, New York.

1. INTRODUCTION

1.1 STATEMENT OF PURPOSE

EA Engineering, P.C., and its affiliate EA Engineering, Science, and Technology, have been retained by The BOC Group (BOC) to develop a Closure Plan for the Witmer Road Landfill parcel in Niagara Falls, New York (Figure 1). The Witmer Road Landfill is part of the Vanadium Corporation of America (Vanadium) site, which has been placed on the New York State Department of Environmental Conservation (NYSDEC) Superfund list. The Vanadium site includes three separate landfilling areas, and three different Potentially Responsible Party groups have been identified by NYSDEC. The three separate landfilled areas are aligned in a roughly west to east fashion (Figure 2), and are commonly known (from west to east) as the SKW parcel, the Airco parcel, and the Niagara Mohawk Power Corporation/New York Power Authority (NMPC/NYPA) parcel. This Closure Plan addresses only the Airco parcel, hereafter referred to as the Airco subsite, or Witmer Road Landfill.

1.2 ORGANIZATION

Chapter 1 outlines the purpose of this Closure Plan and identifies applicable regulatory provisions. Chapter 2 includes a discussion of the site setting, site history, pre-design investigation activities, ecological vectors associated with the landfill, and extent of the waste. Chapter 3 presents a discussion of the landfill cap design features, and identifies variances which have been requested through NYSDEC for the final cover system. The proposed construction schedule, as well as a discussion of post-closure monitoring and maintenance activities, are presented in Chapter 4. Appendix A contains the Post-Closure Monitoring and Facility Maintenance Plan, Appendix B contains the Construction Quality Assurance and Quality Control Plan, Appendix C includes the design specifications, and Appendix D includes the design calculations. The design drawing set is provided under separate cover.

1.3 REGULATORY GUIDANCE

This Closure Plan conforms to the provisions of 6 New York Code of Rules and Regulations (NYCRR) Part 360, Solid Waste Management Facilities (NYSDEC 1998¹), including all applicable subparts. As identified in Section 360-2.15(c)(1), the Closure Plan must:

- Meet the requirements of Paragraphs 360-2.15(b)(1) and (2), and Subdivisions 360-2.15(d) through 360-2.15(j)
- Meet the requirements of Subdivision 360-2.15(k), including the Post-Closure Monitoring and Facility Maintenance Plan (Appendix A) prepared in accordance with Paragraph 360-2.15(k)(7)

1. New York State Department of Environmental Conservation (NYSDEC). 1998. 6 New York Code of Rules and Regulations Part 360, Solid Waste Management Facilities.

- Address unacceptable environmental impacts identified in the Closure Investigation Report required in Paragraph 360-2.15(a)(5)
- Provide an estimate of the landfill area to be covered
- Provide a closure construction schedule which conforms to the requirements of Subdivision 360-2.15(d)
- Provide amended closure and post-closure monitoring and maintenance cost estimates, prepared in accordance with Subdivisions 360-2.19(b) and (c).

2. SITE INFORMATION

2.1 SITE SETTING

The Vanadium site in Niagara Falls, New York is currently listed as a Class 2 site in the New York State Registry of Inactive Hazardous Waste Sites (Site No. 932001). This classification indicates a significant threat to public health or the environment, and requires remedial action. The site consists of three separate properties, as shown on Figure 2:

1. 25-acre parcel (Witmer Road Landfill) owned by Airco, Inc. (known as BOC Group after 1994)
2. 37-acre parcel owned by SKW Alloys, Inc. (SKW subsite)
3. 53-acre parcel owned by NMPC/NYPA.

This report focuses on the Witmer Road Landfill (Airco subsite), although information from the other subsites is used when necessary to develop a clearer understanding of the issues at the Witmer Road Landfill. As required by Subpart 360-2.15(c)(1)(i), the Closure Plan must include a site plan as described in Paragraph 360-2.15(b)(1). The referenced site plan is included as Drawings C-1 and C-2 of the Witmer Road Landfill Closure Construction Drawing set (Appendix C).

2.1.1 Site Access and Easement Agreements

Because the Airco subsite is the middle of three parcels which comprise the Vanadium site, and direct access to a public road does not exist, site access agreements and/or easements with adjacent property owners must be obtained prior to construction activities.

After examining the site plan, the most logical access is from Witmer Road, northwest of the Airco site. The parcel to the north of the Witmer Road Landfill is owned by NMPC and is served by an unpaved access road with an entrance along Witmer Road. Construction traffic would use this route and access the project site from the north.

An additional construction easement will be required to allow access along the eastern, southern, and northern property boundaries for construction related activities. This will be a temporary easement and will be in place for the duration of construction of the cap system.

A meeting with NMPC personnel was attended on 11 January 2000 to discuss obtaining a permanent easement. NMPC personnel indicated that an easement was obtainable and would be granted upon successful completion of an easement application. The easement application was completed and submitted on 24 April 2000.

2.2 SITE HISTORY

As required by Subpart 360-2.15(c)(1)(v), the Closure Plan must provide an estimate of the inventory of wastes in the landfill. The following discussion presents a history of the Vanadium site, including the various landfill operators and inventory of wastes accepted.

The Airco subsite was owned and used by the Vanadium Corporation of America from 1920 to 1964 for disposal of the following materials: stainless steel (lime) slag, ferromanganese slag, ferrochrome silicon slag and dust, and ferrosilicon dust. It is estimated that during the 44 years of operation by Vanadium, 600,000 tons of slag and dust and 90,000 tons of wood, brick, and ash refuse were dumped throughout the Airco subsite and adjacent SKW and NMPC/NYPA subsites.

In 1964, the subsite was sold to Airco Inc., and operated by the Airco Alloys Division. At the time of purchase, the majority of slags onsite were sold to an independent contractor and removed from the subsite. Wastes similar to the Vanadium wastes were generated and disposed onsite from 1964 to 1971. In 1971, the disposal of slurried baghouse dusts was also initiated at the subsite.

Reportedly, between 1971 and 1979, up to 5,600 tons per year of slurried ferrochromium silicon dust and an unknown quantity of other slags and dusts were deposited on the Airco subsite and adjacent SKW subsite. From 1976 to 1979, an additional 8,000 tons per year of slurried ferrosilicon dusts were also disposed on two subsites. From 1979 to 1981, no wastes were disposed on the Airco subsite.

From 1981 through 1988, the subsite was operated as an NYSDEC-permitted landfill by the Airco Carbon Division of Airco, Inc. During this period, inert fire bricks, concrete blocks, coke, and graphite wastes were deposited on the subsite in an effort to obtain a final grade for capping and closure. By 1988, 4 acres in the southern portion of the subsite had been capped through this approach.

In August 1988, Airco, Inc. sold its Niagara Falls production facilities, but not the landfill, to the Carbide/Graphite Group. From 1988 to 1990, no wastes from the Carbide/Graphite Group production facilities were deposited at the subsite, and the landfill permit lapsed. Attempts by Carbide/Graphite Group in 1990 to renew the landfill permit were unsuccessful and, therefore, no waste disposal has occurred at the subsite since 1988. The subsite is currently owned by the BOC Group. In 1994, Airco changed its name to the BOC Group to match part of the parent organization. Currently, approximately 670,000 yd³ of waste occupy the Witmer Road Landfill.

2.3 ENVIRONMENTAL STATUS

Based on conversations with NYSDEC personnel, the investigation phase has been completed to the satisfaction of NYSDEC, and additional investigative activities are not required. However, as required by Subpart 360-2.15(c)(1)(iii), the Closure Plan must address unacceptable environmental impacts identified in previous site investigations. To comply with this requirement and collect additional data to complete the cover design, EA performed pre-design activities from 6 to 15 December 1999.

2.3.1 Pre-Design Investigations

The pre-design activities included leachate and vector surveys, topographic and wetlands surveys, and preliminary determination of the extent of waste fill material.

The pre-design activities were performed to collect data for preparation of the Closure Plan and development of the final design. The pre-design activities performed during the period 6-15 December 1999, and the results of the leachate and vector survey, are discussed below. As required by Subpart 360-2.15(c)(1)(i), the Closure Plan must identify leachate and vector problems and include an appropriate remediation program if warranted.

2.3.1.1 Leachate Survey

A surface condition investigation was conducted on 7 December 1999 to identify the presence of uncontrolled leachate at, or emanating from, the landfill. Two leachate seeps were identified at the Airco parcel. Leachate Seep LS-1 is located on the southwestern side of the property and Leachate Seep LS-2 is located on the eastern side of the property (Figure 3). Both seeps discharge directly into the perimeter swale, which ultimately flows into the adjoining wetlands beyond the property boundary. The leachate seeps are addressed in Section 3.5.

2.3.1.2 Ecological Vector Survey

An ecological vector survey was conducted on 7 December 1999. The survey consisted of walking the perimeter of the site four times and crossing diagonally from several directions over the landfill surface. The presence of vectors was based on direct observations of organisms and secondary observation of wildlife signs (tracks, scat, burrows, etc.). Remnant plant material indicated that the common reed *Phragmites* was the dominant wetland vegetation. Specimens of the following fauna were observed on or immediately adjacent to the site:

- Coyote (*Canis latrans*)
- Red-tailed hawk (*Buteo jamaicensis*)
- Muskrat (*Ondatra zibethicus*)
- Canada goose (*Branta canadensis*).

Signs of the following vertebrates were observed on the landfill:

- Humans (all-terrain vehicle tracks, bottles)
- Coyote/dog (tracks, scat)
- Rabbit (tracks)
- Mouse/mole (burrows, tracks).

The majority of these species do not permanently dwell on the Airco subsite, but gain access to and through the property under or through damaged portions of the perimeter fence. However, mouse/mole burrows were observed at various locations in and around the waste materials. These species are not part of the threatened or endangered list and, therefore, will not be

protected during the design or construction phases. The proposed final cover will eliminate/remove pathways between vectors and contamination.

2.4 EXTENT OF WASTE FILL MATERIALS

In order to minimize the lateral extent of the landfill cap, EA conducted a test-pitting program around the perimeter of the site to determine fill material thickness and lateral extent. This information will be used to determine where waste consolidation is feasible, and where the footprint of the landfill can be reduced. As required by Subpart 360-2.15(c)(1)(iv), the Closure Plan must provide an estimate of the landfill area to be covered. This estimate is provided in Section 2.4.1.

The test pits were dug utilizing a backhoe, an operator, and a supervising engineer. Excavation of the test pits was started onsite where it was likely that waste had been placed, and continued away from the landfill until no further waste was encountered.

EA's supervising engineer monitored each excavation and work space with appropriate monitoring equipment to ensure safe site operations. The supervising engineer field-staked where each test pit began, where waste placement ended, and where the test pit excavation ended; depth of the waste was recorded, if determined. These stakes were surveyed on 13 December 1999 to accurately delineate the edge of the waste. Excavated soil and waste were stockpiled alongside the test pit, and backfilled into the same excavation following completion of each test pit.

Twenty-nine test pits were dug around the perimeter of the landfill from 7 to 9 December 1999. Descriptions of the test pit activities, and associated test pit logs, are included in the variance request letter submitted to NYSDEC on 18 January 2000 (EA 2000²). The supervising engineer exercised latitude on where to place the test pits based on topography, line-of-sight, information contained in available reports, or other site conditions.

The test pit information was utilized to locate areas where additional investigation was performed utilizing a drill rig. As necessary, borings were installed to determine the vertical extent of waste material, and the geotechnical and physical characteristics of the fill and overburden materials. This information was required to determine landfill stability. Sixteen borings were installed to provide the necessary geotechnical information with an emphasis on waste delineation. Descriptions of the soil boring activities, and associated soil boring logs, are included in the variance request letter submitted to NYSDEC on 18 January 2000 (EA 2000). During installation of the soil borings, soil gas monitoring was conducted to determine if gas production was observed. No gas production was identified.

2. EA Engineering, Science, and Technology. 2000. Variance Request from Title 6, Part 360 of the Official Compilation of Codes, Rules, and Regulations for the Witmer Road Design-Build Site Closure Project, Niagara Falls, New York.

2.4.1 Consolidation of Waste Materials

To reduce closure costs, the footprint of the area to be capped will be reduced by consolidating wastes into the center of the site and, where practicable, the perimeter of the site will be excavated down to virgin clay material. This is particularly feasible along the northwestern, western, and southern perimeter, where the waste material extends from 1 to 6 ft below ground surface. Approximately 1 acre of the northwestern Airco property and a majority of the perimeter property line will be excavated to virgin clay (approximately 13,000 yd³ of waste material). The final footprint of the proposed cap and the area(s) to be consolidated is identified on Drawings C-3 and C-4 of the Witmer Road Landfill Closure Construction Drawing set. The remediated area will be restored with topsoil and vegetation growth and used as the support zone with staging for construction and support equipment. Waste consolidation will reduce the area to be capped to approximately 20 acres.

3. LANDFILL CAP DESIGN

This section discusses the design features of the landfill closure, which were prepared to meet the requirements set forth in 6 NYCRR Part 360, Subpart 2.15(d), Final Cover System. The regulations require the following capping components:

- Gas venting layer (12-in. minimum)
- Low permeability layer (18-in. 1×10^{-7} cm/sec clay layer or a 40-mil geomembrane)
- Barrier protection layer (24-in. minimum)
- Topsoil (6-in. minimum).

3.1 REQUESTED VARIANCES TO FINAL COVER SYSTEM

Based on the results of the pre-design investigation, two variances to the capping components listed above were requested in a letter to NYSDEC dated 18 January 2000 and approved on 12 April 2000. One involved eliminating the 12-in. gas vent layer and replacing that layer with a 6-in. bedding layer. Based upon the results of the soil gas monitoring performed during previous soil boring installations (EA 2000), EA has proposed to remove the gas vent layer from the cross-section due to the absence of landfill gases. The replacement of this layer with a 6-in. bedding layer meets the standard of care within the industry for protection of the very flexible polyethylene (VFPE) geomembrane. The second variance involved reducing the 24-in. barrier protection layer to a 12-in. layer and adding a geocomposite drainage layer. Therefore, the proposed final capping components are as follows:

- Bedding layer (6-in.)
- Low permeability layer (40-mil VFPE geomembrane)
- Drainage layer (geocomposite drainage net)
- Barrier protection layer (12 in.)
- Topsoil (6 in.).

Subparts 360-2.15(d)(1) and (d)(2), and Subparts 360-2.15(e) through (h) do not apply because variances have been requested for the gas venting layer and barrier protection layer.

The design cross-section, with the final capping components, is included in Appendix C on Drawings C-5 through C-7 of the Witmer Road Landfill Closure Construction Drawing set. The design cross-sections of the cap system key-in detail (with native soil) are also included on Drawings C-5 through C-7.

3.2 LANDFILL CAP COMPONENTS

3.2.1 Bedding Layer

Due to the inorganic nature of the waste at this site, a gas venting layer is not required beneath the low permeability cap. The waste is primarily slag and dust from the Vanadium and Aircro

operations. Inert fire bricks, concrete blocks, coke, and graphite wastes were also landfilled at the site. Since none of these wastes produce organic gases due to degradation, a variance was requested to eliminate the standard 12-in. gas venting layer but include a 6-in. bedding layer (to protect the VFPE membrane).

The bedding material will conform with the requirements described in the Local Government Regulatory Relief Initiative (NYSDEC 1993³). The material will not be subject to frost heaving during freeze thaw cycles, and will not be capable of causing liner damage due to differential stress caused by freeze thaw cycles.

3.2.2 Low Permeability Layer

An economic analysis was performed on four low permeability layer alternatives that met 6 NYCRR Part 360 requirements, and one that was a variance to the Part 360 requirements. The economic analysis considered the following:

- 18 in. of 1×10^{-7} cm/sec clay
- 40-mil polyvinyl chloride geomembrane
- 60-mil high density polyethylene geomembrane
- 40-mil VFPE geomembrane
- Geosynthetic clay liner (variance required).

The analysis concluded that the most economical low permeability alternative is to utilize either a VFPE geomembrane or a geosynthetic clay liner. The VFPE geomembrane has been selected as the low permeability layer based on cost effectiveness and compliance with 6 NYCRR Part 360. In addition, a variance would have been required to utilize a geosynthetic clay liner.

The use of a 40-mil VFPE geomembrane as the low permeability layer meets the requirements of Subpart 360-2.15(d)(3), and is the current industry standard for closure caps. Installation of a membrane liner eliminates approximately 60,000 yd³ of clay that would be required to meet the regulations, and will reduce the required construction time by approximately 60 working days. The stability of the slopes covered by the VFPE and subsequent cover layers is being evaluated to determine the required friction angle between the VFPE geomembrane and the barrier protection layer to ensure a stable capping system.

3.2.3 Drainage Layer

The drainage layer will consist of a high density polyethylene drainage net-geotextile geocomposite. The drainage net is manufactured by extruding two sets of strands to form a 3-dimensional structure to provide planar water flow. By design, these nets carry large amounts of liquid within their structure and are often called sheet drains. Geotextile filter fabric is heat

3. New York State Department of Environmental Conservation (NYSDEC). 1993. Local Government Regulatory Relief Initiative.

bonded to both sides of the high density polyethylene drainage net to inhibit soil intrusion into the drainage net. The material purchase, transportation, and installation costs of geocomposites is considerably less than for an equivalent sand or gravel drainage system. Also, shear tests on composites with clayey soil indicate friction angles in excess of 30 degrees.

3.2.4 Barrier Protection Layer

The barrier protection layer will consist of a 12-in. layer of 1 in. minus well-graded fill. As stated in the variance request letter to NYSDEC (EA 2000), the advantages of reducing the barrier protection layer thickness by 12 in. are as follows:

- Significant reduction in the amount of material which must be hauled onsite, in turn reducing the use of local natural resources, disruptive truck traffic on the local roads and businesses, and potential dust problems caused by placing the fill
- Significant acceleration of the cap closure schedule which will more quickly reduce potential environmental impacts from the uncapped waste site
- Reduction in total cost of the final cover system without compromising cap integrity.

The 12-in. barrier protection layer, in lieu of the 24-in. barrier protection layer required under Subpart 360-2.15(d)(4), will provide suitable cover to protect the geocomposite drainage layer and 40-mil VFPE geomembrane from surface loading and allow for a stable condition on the final slopes, including an adequate zone for supporting the vegetative layer. It will be sufficient to protect the geomembrane from root penetration without adversely impacting the efficiency of the final cover system. The physical characteristics of this layer are being evaluated as part of the preparation of the design documents.

3.2.5 Topsoil Layer

The required 6-in. topsoil layer is included in the landfill cap design. No deviations from 6 NYCRR Part 360 are proposed for this layer. The topsoil will be free of deleterious material and with a sufficient organic content to support vegetative growth. In accordance with Subpart 360-2.15(k)(6), the vegetative cover will be established within 4 months after placement.

3.3 EASTERN PROPERTY LINE

The eastern property line will require significant regrading to achieve the desired final grades. The regrading will result in the construction of a ridge on the property line that will eliminate surface runoff flow from NMPC onto the Airco property.

Drawings C-7 through C-12 contain the design that depicts the new drainage swales on both the Airco and NMPC subsites. A standard 6 NYCRR 360 closure section (6-in. topsoil, 24-in. barrier protection layer, and an 18-in. 10^{-7} clay layer) was used to address the property boundary.

The proposed cap section will key into the 18-in. clay layer as shown. Disturbed areas on the NMPC parcel will be covered with 3 in. of topsoil, and seeded to prevent erosion.

3.4 STORMWATER MANAGEMENT

Stormwater will be managed at the site in accordance with 6 NYCRR Part 360, Subpart 2.15(k)(2). The cap will be graded and seeded to minimize erosion of the cover soil and minimize ponding on the landfill cap. Perimeter drainage structures will be designed to handle the peak discharge from the 24-hour, 25-year storm.

The existing site drainage pattern will be maintained during and after the interim closure construction as shown on Drawings C-5 through C-12. Water flows around the perimeter of the landfill from a high point on the northeast corner of the site to the wetlands at the southwest corner of the site. The perimeter drainage will remain unchanged.

The perimeter drainage on the eastern property line will require encroachment onto property owned by NMPC, as shown on Drawing C-7 through C-12. Stormwater management on the abutting property will be required to prevent stormwater in contact with waste material on the abutting property from flowing onto the Airco site.

3.5 LEACHATE COLLECTION SYSTEM

As identified in Section 2.3.1.1, two leachate seeps (LS-1 and LS-2) have been identified at the Airco parcel. In accordance with Subpart 360-2.15(i), provisions will be included during construction to control the leachate outbreaks and prevent them from adversely affecting the landfill cover or threatening surface waters. Once the landfill has been capped, the leachate seep will no longer impact surface water, or pose a threat to human health or the environment.

3.6 SITE GRADING

The landfill will be graded to promote positive drainage and minimize erosion of the cover soil. In accordance with 6 NYCRR 360-2.13(r)(2)(ii), the geomembrane cover will be placed at slopes between 4 percent and 33 percent. Most of the landfill will be graded at 4 percent based on the existing topography. Around the perimeter of the landfill, the slopes will be 4-17 percent, except for the south side, which will be 33 percent.

To obtain these grades, the existing waste mass will be regraded. Approximately 45,000 yd³ of waste will be regraded within the limits of the cap to reach the subgrade elevations. In addition, approximately 17,000 yd³ of waste from NMPC's parcel and 13,000 yd³ of waste from the Airco parcel will be excavated and placed under the cap. In total, approximately 75,000 yd³ of waste materials will be regraded. The computer software Terramodel was utilized to balance the cut and fill quantities across the site to minimize the volume of offsite fill needed to reach subgrade elevations.

4. LANDFILL CAP CONSTRUCTION/OPERATION AND MAINTENANCE

This chapter discusses the proposed schedule for closure construction as well as post-closure operation and monitoring activities. Cost estimates associated with closure and post-closure monitoring and maintenance, as referenced in Subpart 360-2.15(c)(1), will be presented under separate cover prior to commencement of construction-related activities. Accordingly, financial assurance for closure monitoring and maintenance (Subpart 360-2.19[b]) will be addressed upon completion of the cap closure and prior to commencement of post-closure activities.

4.1 CONSTRUCTION SCHEDULE

The proposed schedule for closure construction is presented in Figure 4. This schedule conforms to the requirements of Subpart 360-2.15(c). The variances requested for the gas venting layer and barrier protection layer were incorporated into the construction schedule, which significantly reduced the amount of time required for project completion.

Assuming that the closure and post-closure monitoring and maintenance plans are approved and complete prior to 28 April 2000, it is anticipated that contractors will be selected and under contract by mid-May 2000. The mobilization of materials, equipment, and labor to commence construction-phase activities is anticipated to occur by 15 May 2000. Mobilization is contingent upon successful selection of a qualified contractor. It is anticipated that the landfill cap will be significantly complete with the bedding, low-permeable, barrier protection, and vegetative layers in place by 31 October 2000.

4.1.1 Required Air Monitoring During Construction Activities

Fugitive dust suppression, particulate monitoring, and subsequent action levels for such must be used and applied consistently during remedial activities at hazardous sites.

According to the Technical and Administrative Guidance Memorandum No. 4031 (Fugitive Dust Suppression and Particulate Monitoring Program at Inactive Hazardous Waste Sites), the primary standards are $150 \mu\text{g}/\text{m}^3$ over a 24-hour averaging time and $50 \mu\text{g}/\text{m}^3$ over an annual averaging time.

Real time monitoring for volatile compounds and particulate levels at the perimeter of the work area is necessary. Based on the New York State Community Air Monitoring Plan, the following monitoring will be performed:

- Particulates will be continuously monitored upwind, downwind, and within the work area at temporary particulate monitoring stations. If the downwind particulate level is $150 \mu\text{g}/\text{m}^3$ greater than the upwind particulate level, the dust suppression techniques must be employed. All readings must be recorded and available for NYSDEC and New York State Department of Health personnel to review. The closure construction will be performed in accordance with Technical and Administrative Guidance Memorandum No. 4031 and the New York State Community Air Monitoring Plan.

4.2 CLOSURE REPORT AND CONSTRUCTION CERTIFICATION

An Interim Remedial Measure Report, as specified in the Order on Consent, will be prepared to outline the completed activities associated with the closure of the Witmer Road Landfill. The Interim Remedial Measure Report will also include the construction certifications as required under 6 NYCRR Part 360. Certifications are required to provide documentation that the project plans and specifications were met during construction. The certifications will be appended to the Interim Remedial Measure Report as required.

4.3 OPERATION, MONITORING, AND MAINTENANCE

A comprehensive post-closure monitoring and facility maintenance plan has been developed in accordance with Subpart 360-2.15(k) for the site, and is included as Appendix A. Landfill maintenance requirements are briefly summarized in this section and in Appendix A. The monitoring requirements are summarized in Appendix A.

4.3.1 Landfill Maintenance

In accordance with Subpart 360-2.15(k)(3), site inspections will be performed on a quarterly basis to ensure that the final landfill cover and drainage structures are functioning within accepted design standards. The inspections will include visual checks of all culverts, rip-rap, swales, and berms/benches, if present, to ensure erosion problems are not occurring. Erosion occurrences associated with drainage will be repaired and restored. Eroded soil or displaced rip-rap will be replaced. Exposed or unvegetated soil will be reseeded, fertilized, and mulched.

Areas of concern with final landfill cover systems typically include erosion, loss of vegetative cover, and settlement or cracking on the top or side slopes. If cracks or settlement occur, the inspector will determine if the barrier layer is affected.

The presence of any vectors (e.g., rodents, burrowing animals, etc.) on the site will be noted during the routine inspection. Extermination or treatment that will remove the vecting population(s) will be implemented, as appropriate.

Monitoring well casings, locks, fences, and gates will be inspected to ensure that they are undamaged and functional. Damaged components will be repaired immediately and all structures will be re-secured.

Following each inspection, a report will be prepared and submitted to BOC and NYSDEC. The inspection report will include, at a minimum, the date and time of the inspection, personnel conducting the inspection, visual observations of the inspectors, a list of items inspected, and a brief description of any repair work, if required, including the nature of the damage, the repairs completed, and the estimated cost of the repairs. The report will also describe any items that will need future attention or repairs not completed during the course of the inspection, along with other pertinent comments.

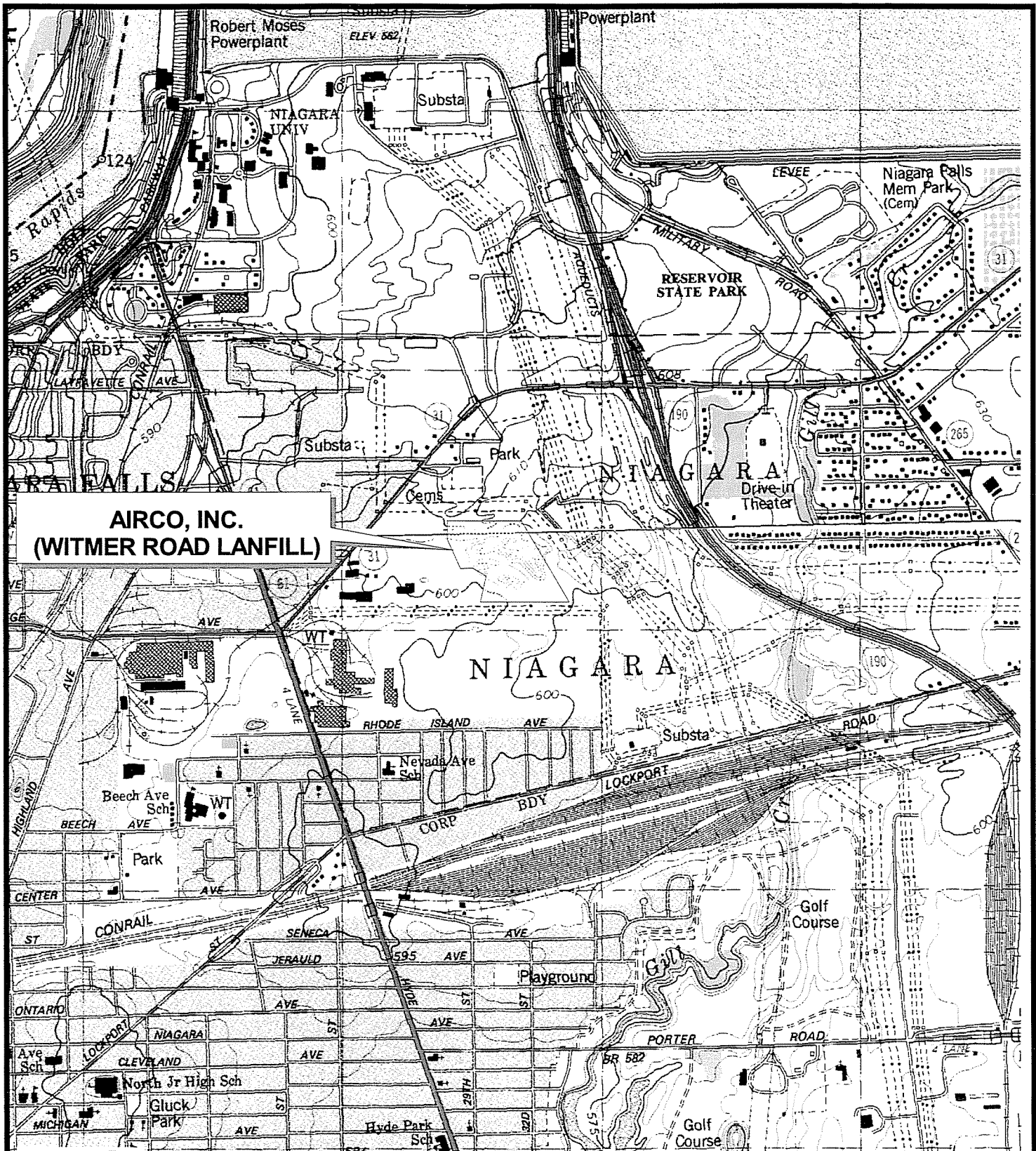

**AIRCO, INC.
(WITMER ROAD LANFILL)**

SOURCE MAP: USGS LEWISTON AND NIAGARA FALLS 7.5 MINUTE QUADRANGLES



EA ENGINEERING,
SCIENCE, AND
TECHNOLOGY

WITMER ROAD LANDFILL DESIGN-BUILD
SITE CLOSURE
NIAGARA FALLS, NEW YORK

FIGURE I
SITE LOCATION MAP

PROJECT MGR	DESIGNED BY	DRAWN BY	CHECKED BY	SCALE	DATE	PROJECT No	FILE No
CEM	BT	BT	CEM	AS SHOWN	30 NOV. 1999	12040.33	I:\BOC-NIAGARA -GIS\BOC.APR

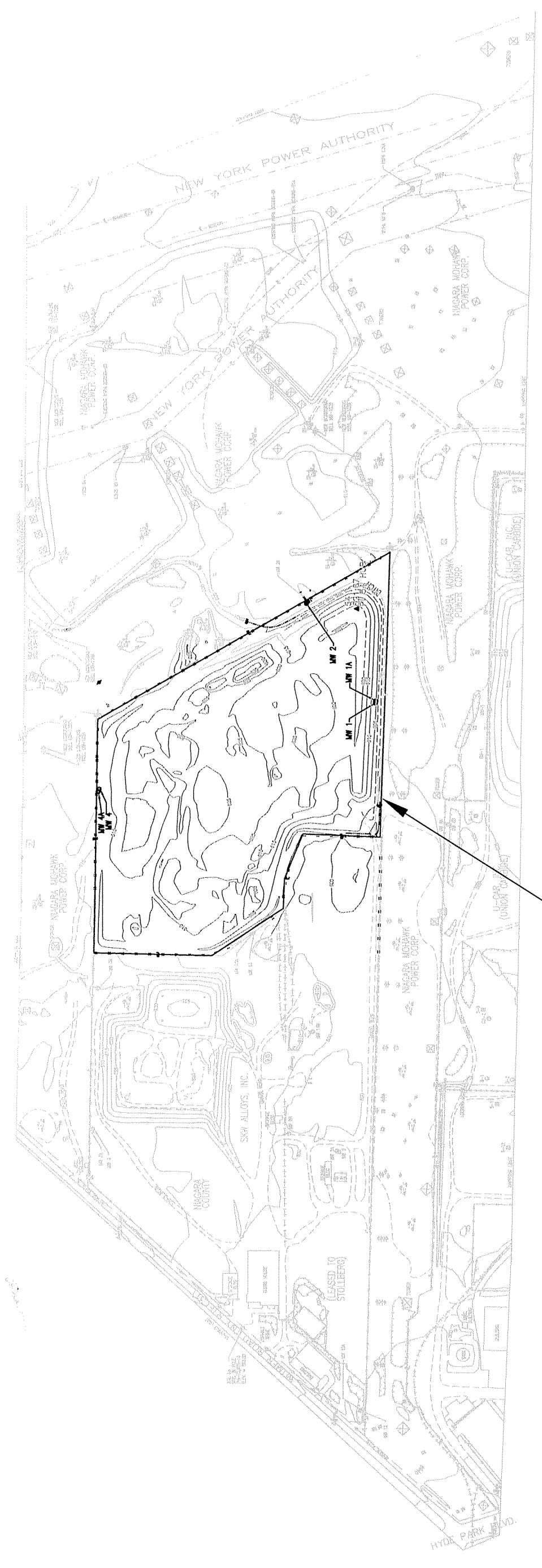

AIRCO, INC.
(WITMER ROAD LANDFILL)

- LEGEND**
- UTILITY POLE
 - PROPERTY IRON PIN
 - TREE LINE
 - ⊃ APPROX. PROPERTY LINE
 - △ SURVEY CONTROL POINT
 - x-x-x CHAIN LINK FENCE

- REFERENCES:**
1. HORIZONTAL CONTROL FOR THIS PROJECT WAS TIED INTO NAD 1983. MONUMENTS SMC-20A AND SMC-45 FROM A GS CONTROL PROJECT IN 1991 FOR THE CITY OF NIAGARA FALLS WAS USED.
 2. VERTICAL CONTROL FOR THIS PROJECT WAS TIED INTO NGVD 1929. MONUMENT SMC-20A WITH AN ELEVATION OF 588.52 WAS USED. A SECONDARY BENCHMARK (RAILROAD SPIKE IN POLE NM-73, NYT-10) WAS SET BY LU ENGINEERS WITH AN ELEVATION OF 599.00.
 3. TOPOGRAPHIC MAPPING AND 5-FT CONTOURS FOR THIS PROJECT WERE BASED ON 1"=500' PHOTOGRAPHY OBTAINED IN THE SPRING OF 1992.
 4. ALL PROPERTY LINE LOCATIONS ARE APPROXIMATE. NO BOUNDARY SURVEY WAS DONE. EXISTING SURVEYS WERE UTILIZED FROM SKW ALLOYS, INC. DATED 18 FEBRUARY 1988. UNION CARBIDE LANDFILL SITE PLAN DATED 30 DECEMBER 1983, AND NEW YORK STATE POWER AUTHORITY DRAWING "NPPSKWDWG."



	WITMER ROAD LANDFILL DESIGN-BUILD SITE CLOSURE NIAGARA FALLS, NEW YORK	FIGURE 2 VANADIUM SITE		DESIGNED BY MJG	DRAWN BY JBS	DATE 10-18-99	PROJECT NO. 12040.33
				CHECKED BY PAP	PROJECT MGR. CEM	SCALE AS SHOWN	FIGURE 2

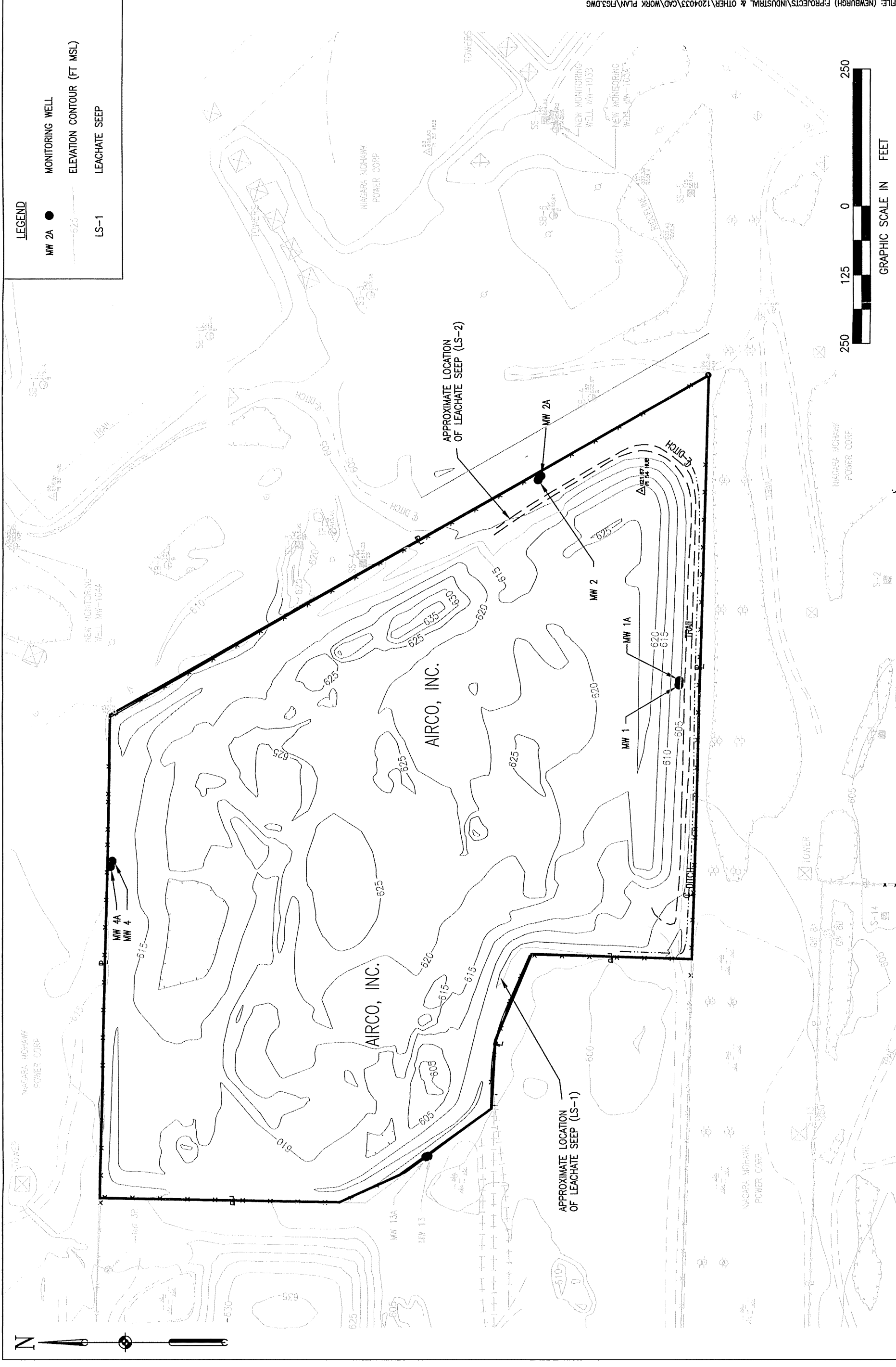

LEGEND

- MW 2A ● MONITORING WELL
- ELEVATION CONTOUR (FT MSL)
- LS-1 LEACHATE SEEP



EA EA ENGINEERING, SCIENCE, AND TECHNOLOGY	WITMER ROAD LANDFILL DESIGN-BUILD SITE CLOSURE NIAGARA FALLS, NEW YORK		FIGURE 3 APPROXIMATE SEEP LOCATIONS		DESIGNED BY MJG	DRAWN BY JBS	DATE 03-16-00	PROJECT NO. 12040.65
					CHECKED BY PAP	PROJECT MGR. CEM	SCALE AS SHOWN	FIGURE 3

FILE: (NEWBURGH) F:\PROJECTS\INDUSTRIAL & OTHER\1204033\CAD\WORK PLAN\FIG3.DWG

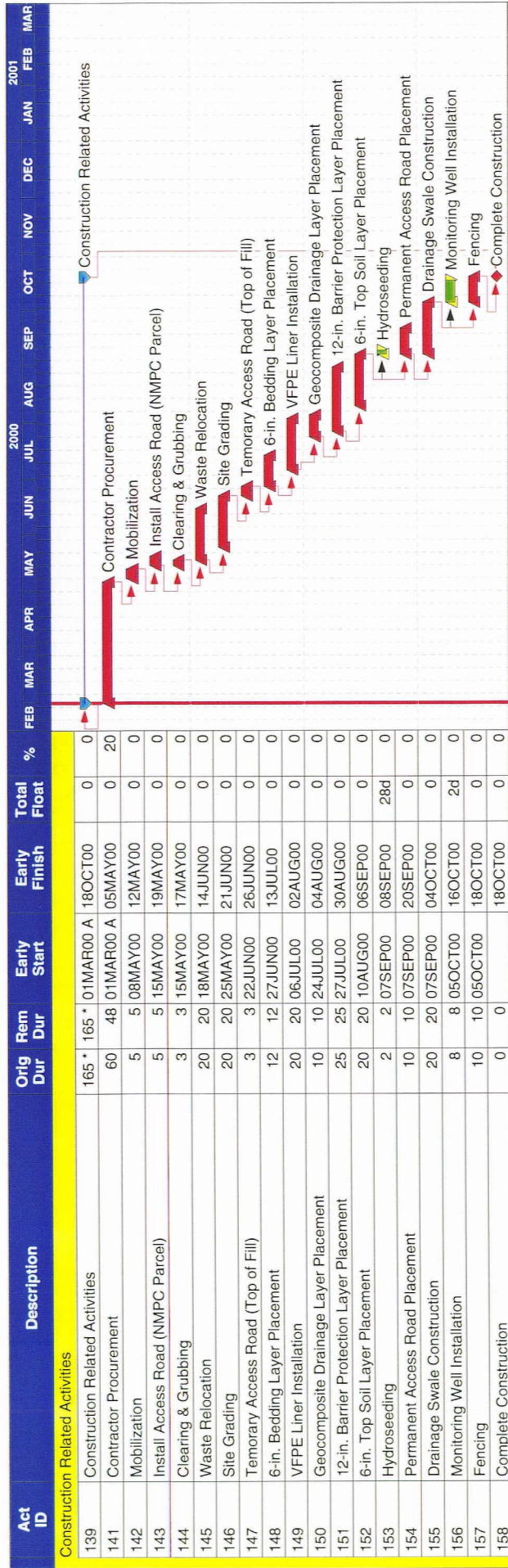

Appendix A

Post-Closure Monitoring and Facility Maintenance Plan

**Post-Closure Monitoring and Facility
Maintenance Plan for the
Witmer Road Landfill
Niagara Falls, New York**

Prepared for

The BOC Group
100 Mountain Avenue
Murray Hill, New Jersey 07974

Prepared by

EA Engineering, P.C. and Its Affiliate
EA Engineering, Science, and Technology
3 Washington Center
Newburgh, New York 12550
(914) 565-8100

April 2000
Revision: FINAL
Project No. 12040.65

**Post-Closure Monitoring and Facility
Maintenance Plan for the
Witmer Road Landfill
Niagara Falls, New York**

Prepared for

The BOC Group
100 Mountain Avenue
Murray Hill, New Jersey 07974

Prepared by

EA Engineering, P.C. and Its Affiliate
EA Engineering, Science, and Technology
3 Washington Center
Newburgh, New York



20 April 2000

David S. Santoro, P.E., L.S.
President, EA Engineering, P.C.

Date

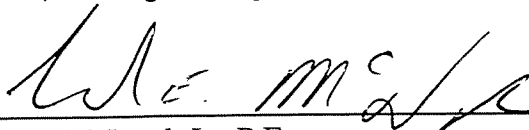

20 April 2000

Charles E. McLeod, Jr., P.E.
Project Manager/Program Manager
EA Engineering, Science, and Technology

Date

April 2000
Revision: FINAL
Project No. 12040.65

CONTENTS

	<u>Page</u>
LIST OF FIGURES	
LIST OF TABLES	
1. INTRODUCTION.....	1
1.1 Statement of Purpose.....	1
1.2 Organization.....	1
2. MAINTENANCE INSPECTIONS.....	2
2.1 Drainage Structures.....	2
2.2 Cover System.....	2
2.3 Vectors.....	3
2.4 Other Facilities and Structures.....	3
2.5 Quarterly Inspection Reports.....	3
2.6 Annual Inspection Reports.....	3
3. ENVIRONMENTAL MONITORING PROGRAM.....	4
3.1 Monitoring Well Abandonment.....	4
3.2 Monitoring Well Installation.....	5
3.2.1 Well Construction.....	6
3.2.1.1 Casing/Screen Installation.....	6
3.2.1.2 Filter Pack.....	6
3.2.1.3 Bentonite Seal.....	7
3.2.1.4 Annular Seal.....	7
3.2.1.5 Surface Completion.....	7
3.3 Well Development.....	8
3.4 Ground-Water Sampling.....	8
3.4.1 Ground-Water Gauging.....	9
3.5 Surface Water Sampling.....	9
3.6 Field Quality Control Samples.....	9
3.6.1 Water Source Sample.....	9
3.6.2 Rinsate Blanks.....	10
3.6.3 Field Duplicates.....	10
3.6.4 Trip Blanks.....	10
3.6.5 Sample Labels.....	10

	<u>Page</u>
3.7 Sample Kits and Handling.....	11
3.8 Sample Documentation in the Field	11
3.9 Decontamination Procedures.....	12
3.10 Investigation-Derived Wastes	12
3.11 Location Surveying	13
4. SAMPLING FREQUENCY AND DATA REPORTING	14
4.1 Sampling Frequency.....	14
4.1.1 Ground-Water Sampling	14
4.1.2 Surface Water Sampling.....	15
4.2 Data Reporting	15
ATTACHMENT A: FIELD FORMS	
ATTACHMENT B: STANDARD OPERATING PROCEDURES FOR LOW FLOW AND SAMPLING METHOD	

LIST OF FIGURES

<u>Number</u>	<u>Title</u>
1	Water quality sampling location map, Witmer Road Landfill Design-Build Site Closure, Niagara Falls, New York.
2	Overburden monitoring well construction diagram, Witmer Road Landfill Design-Build Site Closure, Niagara Falls, New York.

LIST OF TABLES

<u>Number</u>	<u>Title</u>
1	Summary of analytical methods, reporting limits, and standards for baseline parameters for ground-water samples collected at Witmer Road Landfill, Niagara Falls, New York.
2	Summary of sample containers, preservation techniques, and holding times for ground-water samples collected at Witmer Road Landfill, Niagara Falls, New York.

1. INTRODUCTION

1.1 STATEMENT OF PURPOSE

This Post-Closure Monitoring and Facility Maintenance Plan has been prepared for the Witmer Road Landfill located on Witmer Road in the Town of Niagara Falls, New York. This plan describes the tasks necessary for maintenance of the site, periodic inspections, and the monitoring of ground water and surface water at the facility. The intended use for this plan is to provide a guide to the current landfill owners for maintenance and facility monitoring for a period of 30 years. The plan will be re-evaluated within the first 5 years of quarterly monitoring.

In general, the following is required as part of the Post-Closure Monitoring and Facility Maintenance Plan:

- All drainage structures and ditches must be maintained to prevent ponding and erosion of the final landfill soil cap.
- Soil cover integrity, slopes, cover vegetation, drainage structures, and the perimeter road must be maintained during the post-closure monitoring and maintenance period.
- Environmental monitoring points must be maintained and sampled during the post-closure period. Quarterly and annual summary reports must be submitted to Ms. Mary E. McIntosh, Engineering Geologist II, Division of Solid and Hazardous Materials, New York State Department of Environmental Conservation (NYSDEC) Division of Solid Waste, Region 9.
- A vegetative cover must be established and maintained on all exposed final cover material, and adequate measures must be taken to ensure the integrity of the final vegetated cover, topsoil layer, and underlying barrier protection layer.
- Records must be maintained of all sampling and analysis results.

1.2 ORGANIZATION

Section 1 outlines the purpose of this Post-Closure Monitoring and Facility Maintenance Plan, and identifies applicable regulatory provisions. Section 2 includes a discussion of the maintenance inspections. Section 3 outlines the environmental monitoring program. The proposed sampling frequency and data reporting are presented in Section 4. Attachments A.1 through A.5 contain the field forms (Soil Boring Log; Field Record of Monitoring Well Construction; Field Record of Well Development; Field Record of Well Gauging, Purging, and Sampling; and Landfill Cap Inspection Checklist), and Attachment B outlines the standard operating procedures for low flow and sampling method.

2. MAINTENANCE INSPECTIONS

Quarterly landfill inspections, and inspections after major rainfall events (5-year storms), shall be performed at the facility during the minimum 30-year post-closure period, unless specific approval is given by NYSDEC to eliminate some or all of these requirements. The inspections shall be performed on the facility to ensure that the final landfill cover materials, the site drainage structures, and onsite monitoring wells are maintained and functioning within the design standards. Advance notification of inspections will be made to NYSDEC 72 hours prior to commencement of inspection-related activities in the event NYSDEC attendance is desired. An example of the inspection checklist is provided in Attachment A.5. The quarterly landfill inspection reports will be submitted to NYSDEC along with the quarterly ground-water and surface water monitoring reports.

2.1 DRAINAGE STRUCTURES

The inspections will include visual checks of culverts, drainage swales, and berms/benches, if present, to ensure erosion problems are not occurring. Any material defects and erosion occurrences discovered at the facility will be repaired immediately and restored to "new" condition. Eroded soil or cover material will be replaced as soon as possible. Exposed or unvegetated soil will be re-seeded, fertilized, and mulched.

2.2 COVER SYSTEM

Areas of concern within the final landfill cover system could include erosion, exposure, loss of vegetative cover, settlement, gravity sliding, or cracking on the top or side slopes of the landfill. Each quarter, the cover system, including topsoil layer and barrier protection layer, the geocomposite drainage layer, and the 40-mil very flexible polyethylene (VFPE) membrane, will be inspected and records will be maintained.

Minor repairs to the cover system will be done by hand, utilizing materials from the original borough source or newly approved borough source. The areas of minor erosion, sloughing, or cracking will be excavated by hand to allow for a concise repair. Materials will be placed, compacted appropriately by hand, and re-seeded. Additional erosion control measures, such as straw or hay bales, will be used accordingly to prevent future damage to the repaired areas.

In the event that major erosion, sloughing, or slumping is noted during an inspection, NYSDEC personnel will be notified within 48 hours of the problems observed. An action plan detailing the remedial measures to be taken to rectify the problem will be developed and submitted to NYSDEC for approval, prior to implementation of the remedy. Any repairs requiring patching or seaming of the VFPE membrane or geocomposite drainage layer will be conducted in accordance with manufacturers' construction specifications and outlined in the action plan.

2.3 VECTORS

The vector inspection in December 1999 indicated that vectors do not appear to pose a threat to the proposed landfill cap section. However, it is recognized that the habitat will be significantly improved after closure has been completed. The presence of any vectors (e.g., rodents, flies, etc.) on the site will be determined during the quarterly inspection. If present, extermination or treatment that will remove the vecting population(s) shall be implemented.

2.4 OTHER FACILITIES AND STRUCTURES

All monitoring well casings, casing locks, concrete aprons, site fences, and gates will be inspected to ensure that they are undamaged and functional. Damages will be repaired immediately and structures re-secured. Mowing of the cap system will occur three times during the first growing season to allow for re-germination of the vegetative cover, and annually thereafter. Annual mowing will be performed after 1 September to allow for enhancement of avian wildlife habitat.

2.5 QUARTERLY INSPECTION REPORTS

After each quarterly inspection, a report will be prepared and submitted to NYSDEC Division of Solid and Hazardous Materials Region 9 office. The inspection report will include, at a minimum, the date and time of the inspection, personnel conducting the inspection, visual observations of the inspectors, a list of items inspected, and a brief description of any repair work, if required, including the nature of the damage, the repairs completed, and the estimated cost of the repairs. The report will also describe any items that will need future attention or repairs not completed during the course of the inspection, along with any other pertinent comments. Three copies of the quarterly inspection and quarterly monitoring reports will be submitted to NYSDEC Region 9; one copy to the State of New York Department of Health in Albany, New York; and one copy included in the document repository located at the Town of Niagara Town Clerk's Office at 7105 Lockport Road, Niagara Falls, New York.

2.6 ANNUAL INSPECTION REPORTS

A brief summary report will be prepared annually and submitted outlining the previous year's monitoring and maintenance activities. The report will describe the previous year's trends with regards to constituents of concern, inspection report findings, and associated remedies, if required. Three copies of the quarterly inspection and quarterly monitoring reports will be submitted to NYSDEC Region 9; one copy to the State of New York Department of Health in Albany, New York; and one copy included in the document repository located at the Town of Niagara Town Clerk's Office at 7105 Lockport Road, Niagara Falls, New York.

3. ENVIRONMENTAL MONITORING PROGRAM

This section provides a summary of the field activities that will be conducted in order to establish the post-closure environmental monitoring system at the Witmer Road Landfill. Activities to be conducted at the site included:

- Monitoring well abandonment
- Monitoring well installation
- Monitoring well development
- Ground-water sampling
- Surface water sampling.

3.1 MONITORING WELL ABANDONMENT

There are 8 existing wells at the Witmer Road Landfill site located close to the edge of or within the waste mass, which were installed in December 1978. Due to the age and location of these monitoring wells (located within the areas of proposed closure construction activities), the 8 wells will be properly abandoned in accordance with 6 NYCRR Part 360 Solid Waste Management Facilities regulations under Section 360-2.11. Proper well abandonment is necessary in order to prevent contaminant migration through the existing borehole. The 8 monitoring wells to be abandoned include the shallow monitoring wells (MW-1A, MW-2A, MW-4A, and MW-13A) and the deeper monitoring wells (MW-1, MW-2, MW-4, and MW-13). Well abandonment will include the following procedures:

- Removal of the existing casing, to the greatest extent possible, followed by perforation of any casing left in place. All casing and well installations in the upper 5 ft of the boring or within 5 ft of the proposed level of excavation must be removed.
- The borehole will be sealed by pressure injection with cement bentonite grout, using a “tremie” pipe or other method acceptable to NYSDEC. The screened interval of the borehole will be sealed separately and tested to ensure its adequacy before sealing the remainder of the borehole. Where the surrounding geologic deposits are highly permeable, alternate methods of sealing may be required to prevent migration of the grout into the surrounding geologic formation. The upper 5 ft will be backfilled with the appropriate native material compacted to avoid settlement.
- The sealed borehole site will be restored to a safe condition. The well abandonment sites will be inspected periodically, during the quarterly inspections, after sealing for settlement, or other conditions which may require remediation and repair.

3.2 MONITORING WELL INSTALLATION

Ground-water monitoring wells will be installed in order to assess the chemical quality of onsite ground water in the saturated zone, and to evaluate the migration or potential for migration of constituents of concern (if present) to offsite receptors. A total of 8 new monitoring wells will be installed along the perimeter of the waste mass at the Witmer Road Landfill (Figure 1).

Monitoring well MW-1B will be designated as the upgradient well, with the remaining 7 monitoring wells (MW-2B through MW-8B) as downgradient wells. Protocols outlined in the current U.S. Environmental Protection Agency (EPA) guidelines as specified in EPA/600/4-89/034 (*Handbook of Suggested Practices for the Design and Installation of Ground-Water Monitoring Wells*, March 1991) will be followed for well installation and development.

Continuous split-spoon sampling will be conducted during the soil boring of the monitoring well. Split-spoon soil samples will be collected and securely stored and accessible until acceptance of the Interim Remedial Measure Report by NYSDEC personnel. No analytical samples will be collected, however, field observations will be recorded by the field geologist. Soil samples will be visually identified using the Unified soil Classification System and recorded on a geologic log for each boring (Attachment A.1). The following information will be recorded by the field geologist:

- Soil sample and depth interval
- Blow count (per 6-in. interval)
- Amount of sample recovered
- Sample color
- Sample moisture concentration
- Organic vapor (photoionization detector) measurements
- Any unusual characteristics (odors, stained intervals)
- Depth to water.

The 8 new monitoring wells will be installed in the deeper overburden to an estimated maximum depth of 20 ft below ground surface (bgs) within the dense glacial till. The glacial till consists of a variety of non-sorted, non-stratified mixture of sand, silt, gravel, and rock fragments. During the December 1999 soil boring investigation, the till unit was characterized as a dense heterogeneous mixture of reddish brown clay, silt, sand, gravel, and dolostone bedrock. This till mantles the underlying dolostone bedrock (part of the Lockport Group) beneath the site and underlies the glaciolacustrine deposits beneath the fill. The glaciolacustrine deposits consist of primarily silt, fine sand, and clay with some stratification of sediments.

Each monitoring well will have a 5-ft screen section to provide a discrete sampling interval. The exact depth of the screened intervals will be determined based on site conditions noted during the soil boring and soil lithology logging program by the field geologist. Each newly installed monitoring well will be developed using pump and surging methods until ground-water parameters (pH, temperature, and conductivity) stabilize and turbidity is minimized.

3.2.1 Well Construction

Following soil boring, well construction will be performed according to the procedures described below. The actual well completion data will be recorded on the Field Record of Monitoring Well Construction form provided in Attachment A.2.

3.2.1.1 Casing/Screen Installation

New polyvinyl chloride riser casing and well screen will be used in well construction. Material will be delivered directly to the field in packaging from the manufacturer. Well riser casing and screen sections will be steamed cleaned onsite prior to placement if the packaging is not intact to ensure that oil, grease, or wax have been removed. After the borehole has been drilled to the depth determined by the field geologist, 2-in. inner diameter Schedule 40, threaded, flush-jointed polyvinyl chloride screen and polyvinyl chloride riser casing will be set through the hollow-stem augers into the borehole. Screen slot size will be 0.010 in. unless geologic conditions, in the judgement of the field geologist, dictate differently. The screen interval will be placed at the bottom of the boring at the proper depth necessary to monitor the ground-water quality within the lower till unit directly above the dolostone bedrock. Wells will be completed with 5 ft of screen; however, this length may vary depending on site-specific conditions, as determined by the field geologist. No sediment traps will be used to cap the screen bottom. The riser casing completion is outlined in Section 3.2.1.5.

3.2.1.2 Filter Pack

Inert silica sand, certified as chemically clean by the manufacturer, and texturally clean (as seen through a 10X hand lens), will be used. The nominal grain size of the filter pack surrounding the screen will be No. 00 silica sand unless geologic conditions, in the judgement of the field geologist, dictate differently. Prior to installing the screen, a bentonite seal (with a minimum 1-ft thickness) and an overlying 6-in. thick (minimum) bedding of filter pack will be placed in the bottom of the hole (as shown on Figure 2). Next, the well screen and riser casing will be installed and the sand pack will be added. Auger flights will be progressively removed from the borehole allowing the auger to act as a tremie. Sand will be added to a depth of approximately 2 ft above the top of the well screen. The 2 ft of filter pack above the top of the screen allows for some settlement of the filter pack and a buffer between the top of the well intake and the annular seal. A finer filter pack (No. 000) 6-in. thick will be added to further control the entrance velocities at the well screen (Figure 2). The depth to the top of the filter pack will be sounded frequently with a weighted measuring tape. If bridging of the material does occur, a tremie pipe and/or a small amount of clean, potable water may be used to remove the bridge and allow the filter pack to settle correctly. The filter pack will not be placed higher than approximately 4 ft bgs in order to allow space for placement of bentonite seal and protective casing with cement-bentonite grout.

3.2.1.3 Bentonite Seal

Bentonite seals will be composed of commercially available pellets. Pellet seals will be a minimum of 3-ft thick as measured immediately after placement, without allowance for swelling. The bentonite seal will not be placed higher than 2 ft bgs in order to allow space for placement of protective casing with cement or cement-bentonite grout. Following placement of the pellets, clean, potable water will be poured down the annular space to hydrate the pellets. Pellets will be allowed to hydrate for 4 hours prior to grouting the remainder of the borehole.

3.2.1.4 Annular Seal

The annular seal will consist of cement-bentonite grout, composed by weight of 10 parts cement (Portland cement, any Type I to V) to one-half part bentonite with a maximum of 7 gal of approved water per 94-lb bag of cement. Bentonite will be added after the required amount of cement is mixed with water. Additives or borehole cuttings will not be mixed with the grout. Annular seal materials will be combined in an aboveground rigid container and mixed onsite to produce a thick, lump-free mixture.

The annular seal will be placed utilizing a tremie pipe, initially located within 1 ft above the top of the bentonite seal. The tremie pipe should be placed in the annulus between the augers and the riser pipe. The auger should be removed from the borehole as the annular seal fills the borehole at a rate compatible with annular seal placement so as to maintain borehole stability. The grout will be pumped through the tremie pipe to the bottom of the open annulus until a continuous, undiluted column of grout is formed from the bentonite seal to the frost line below ground surface.

3.2.1.5 Surface Completion

The newly installed wells will extend (up to 2 ft) above the ground surface, with a protective steel casing, similar to the existing wells at the site. The cement seal will be formed utilizing a 3-ft diameter sonotube to a depth of 4 ft bgs. The top outer edge of the pad will be flush with the ground. An internal grout collar will be placed in the annular space between the inner casing and the outer protective casing. Brass locks that are keyed alike will be used to secure the outer lids of the protective casing of the wells. For wells completed above land surface, the cement seal will fill the borehole annular space from below the frost line to the ground surface. The protective casing will be washed with clean water or steam-cleaned prior to placement, free from extraneous openings, encrusting, and/or coating material (except primer/paint applied by the manufacturer). Each well will be provided with brass locks and lockable caps. A copy of the well keys will be provided to NYSDEC upon well completion.

If water is used during drilling, any losses will be recorded and well development (prior to purging for sampling purposes) will remove at least the amount of water lost during drilling.

Traffic is not anticipated near the monitoring wells because they will be installed outside of the perimeter swale and the access road is inside of the perimeter swale. If the monitoring wells are moved and installed near the access road, protective measures will be installed to protect the wells from the traffic.

3.3 WELL DEVELOPMENT

Proper well development is necessary to remove silt from the well to ensure that representative ground-water samples can be obtained from the well. Wells will be developed within 1 week after each well has been constructed, but no sooner than 48 hours after grouting is completed.

Each well will be alternately mechanically surged with a surge block and pumped clear of sediment used during drilling activities or with a submersible pump. Low yielding wells may be hand bailed. If the addition of water is used during drilling activities, or is required to facilitate surging and bailing, water from that well or water from the approved potable water source will be used, and at least as much water as was introduced during development will be removed from each well. Care will be taken during surging to ensure that low pressures within the well casing do not cause implosion of the screen. Surging will continue until little or no sediment enters the well, or a maximum of 2.5 hours of development has occurred. At the end of that time, the well will be continuously pumped using a submersible, pneumatic drive positive displacement of bladder pump. Temperature, pH, specific conductivity, and turbidity will be monitored during pumping at a rate of one reading per casing volume removed. Turbidity will be measured as soon as the sample is brought to the surface. Pumping will continue until these parameters have stabilized (less than 0.2 pH units or a 10 percent change for the other parameters between four consecutive readings) and the turbidity does not exceed 5 nephelometric turbidity units. Failure to obtain satisfactory results will be noted on the well development record sheet. The purged ground water derived from well development will be contained in 55-gal containers and taken offsite. A copy of the Field Record of Well Development form to be completed during the development program is provided in Attachment A.3.

3.4 GROUND-WATER SAMPLING

The monitoring wells at the site will be sampled using the low-flow sampling methods, presented in Attachment B. Prior to sampling, each well will be monitored until temperature, pH, specific conductivity, and turbidity parameters have stabilized. Results will be logged on the Field Record of Well Gauging, Purging, and Sampling included in Attachment A.4. The samples will be analyzed for baseline parameters in accordance with NYSDEC NYCRR Part 360-2.11(d)(6), including volatile organic compounds by EPA Method 8260B, metals by EPA Series 6010/7000, and additional parameters provided in *Methods for Chemical Analysis of Water and Wastes* (EPA-600/4-79-020), including total organic carbon, total dissolved solids, chemical oxygen demand, specific conductivity, and pH. Table 1 includes a list of baseline parameters that will be analyzed. Based on the results of the first two ground-water sampling rounds, the analytical parameters sampled and the frequency of sampling at each monitoring well location will be evaluated, and the list of analytes will be modified. If constituents of concern are reported in the

overburden monitoring wells, then the installation of at least 1 bedrock well may be required to determine if impacts to the bedrock aquifer have occurred. An addendum to this plan will be issued detailing the necessary information for bedrock well installation, if required.

3.4.1 Ground-Water Gauging

In order to evaluate the ground-water flow direction at the site, ground-water level gauging will be performed on the onsite wells prior to sample collection. An electronic water level meter will be used for this field task capable of recording water elevations to within +/- 0.01-in. accuracy. A complete round of water elevation measurements will also be recorded 1 day following completion of well installation activities.

3.5 SURFACE WATER SAMPLING

Surface water sampling is designed to evaluate the chemical quality surface water runoff which may collect in the drainage swales prior to exiting the site to the south. Surface water samples will be collected at one location (Figure 1), if surface water is present during sampling events. The one location noted is the confluence point for the eastern and western drainage swales. Samples will be collected using a decontaminated stainless steel or Teflon dipper. Samples will be analyzed for the following parameters:

- pH
- Specific conductivity
- Total dissolved solids
- Chemical oxygen demand
- Total organic carbon
- Barium
- Hexavalent chromium
- Total chromium
- Iron
- Manganese
- Silica
- Zinc.

Based on the results of the first two sampling rounds, analytical parameters may be modified.

3.6 FIELD QUALITY CONTROL SAMPLES

These samples are not included specifically as laboratory quality control samples but are analyzed when submitted. Data for these quality control samples are reported with associated samples.

3.6.1 Water Source Sample

Water source samples are samples of water used for field decontamination purposes. Specifically, water source samples will include potable, site-supplied water used in decontamination activities and laboratory-supplied, reagent-grade, de-ionized water used for final rinse in decontamination activities. Water source samples will be analyzed for the parameters sampled during the field mobilization period. One water source sample will be

collected from the source of potable water used for equipment decontamination per sampling event. The water source sample will be collected early in the field effort to assess the quality of this potable water supply.

3.6.2 Rinsate Blanks

A rinsate blank is a water sample collected after having been poured through or over a decontaminated piece of sampling equipment to assess and document the thoroughness of the decontamination process. At least one rinsate blank per sampling event will be collected.

3.6.3 Field Duplicates

Field duplicates are two samples of the same matrix which are collected, to the extent possible, from the same location at the same time using the same techniques. Field duplicates provide information on the precision of the sampling and analysis process. Field duplicates will be collected at a frequency of 1 duplicate per 20 sample media. Quality control samples will be filled from the same discrete sample or composite mixture as the field samples.

3.6.4 Trip Blanks

Trip blanks are samples used when shipping samples for volatile organic compound analysis, in order to determine if volatile organics were released during shipment. These samples consist of a 40-ml sample vial containing laboratory grade deionized water. One trip blank will accompany each sample shipment (cooler) containing volatile organic compounds.

3.6.5 Sample Labels

Field samples collected will each be assigned a unique sample tracking number. Sample designation will be an alpha-numeric code which will identify each sample by site and location.

Sample Codes:

WRL = Witmer Road Landfill
MW = Monitoring well
SS = Surface water
RB = Rinsate blank
TB = Trip blank
DUP = Duplicate
SWB = Source water blank.

For example, the ground-water sample from MW-1B will be labeled WRL-MW-1B. Quality control samples will be labeled by the type of sample followed by a sequential numerical identification. For example, the first trip blank will be named TB-01. In order to ensure blind laboratory analysis of duplicate samples from specific matrixes, "DUP" will replace the sample

identification number. This will ensure that the laboratory cannot identify the location of the duplicate sample. For example, the first ground-water duplicate sample collected will be identified as DUP-01.

3.7 SAMPLE KITS AND HANDLING

Sample kits, which are coolers containing chain-of-custody forms, custody seals, sample containers (with preservatives), and packing material, are prepared by the laboratory. The chain-of-custody procedure begins with the preparation of sample containers and preservatives to be used in sample collection. Unless superseded by specific project requirements, the contracted laboratory purchases and distributes pre-cleaned sample containers. Vendors are required to provide documentation of analysis for each lot of containers, and the documentation is kept on file.

For the analyses specified for this project, Table 2 shows general guidelines for the type of sample container required, preservation techniques, and holding times for analytical samples collected. Preservatives will be added to the sample containers in the laboratory prior to shipment.

After the samples are collected, they are split as necessary among containers and preservatives appropriate to the parameters to be determined. Each container is provided with a sample label that is filled out at the time of collection. At this time, a chain-of-custody form is initiated. The collected samples are cooled, if necessary, and returned to the laboratory by the most expedient means to ensure that holding times will be met. The chain-of-custody form is signed and dated as necessary as the samples pass from the collectors to those persons responsible for their transportation.

3.8 SAMPLE DOCUMENTATION IN THE FIELD

Field personnel will be issued serialized weatherproof logbooks. Field personnel are responsible for recording all pertinent project information including, but not limited to, field work documentation; field instrumentation readings; calculations; calibration records; work plan distributions; photograph references; sample tag/label numbers; meeting information; and important times and dates of telephone conversations, correspondence, or deliverables. This field logbook will also contain an abbreviated version of notes listed in the team or individual field logbooks. The sample team or individual performing a particular sampling activity is required to maintain a field logbook that will be filled out at the location of sample collection immediately after sampling. It will contain sample particulars including sample number, sample collection time, sample location, sample descriptions, sampling methods used, daily weather conditions, field measurements, name of sampler, and other site-specific observations. The field logbook will also address deviations from this Plan or the Health and Safety Plan, including authorization obtained and the rationale for the deviation, visitor's names or community contacts during sampling, and geologic and other site-specific information determined by field personnel

as noteworthy. A sample log sheet will be filled out for each sample from the information recorded in the field logbook. In addition, field personnel will use appropriate forms applicable to field activities. These include boring logs, sampling data sheets, and calibration records.

3.9 DECONTAMINATION PROCEDURES

To minimize the potential for cross-contamination between sample locations, reusable sampling and drilling equipment which contacts site soil will be decontaminated via steam cleaner wash before and after the first well is installed and after each subsequent well installation. Additionally, the upgradient well (MW-1B) will be drilled first to minimize cross-contamination. Steam cleaning will be conducted between each boring on a pre-approved (by supervising geologist as coordinated with Witmer Road Landfill site personnel), centrally located decontamination pad.

The procedure for cleaning stainless steel pumps, dippers, and water level/interface probes is as follows:

- Wash with potable water and laboratory-grade detergent (e.g., Alconox[®] detergent)
- Rinse with potable water
- Rinse with deionized water
- Rinse with methanol
- Rinse with deionized water
- Air dry
- Wrap in aluminum foil if equipment will be stored.

The decontamination area will contain a wash solution collection system. The collected material will be contained in U.S. Department of Transportation-approved 55-gal drums.

3.10 INVESTIGATION-DERIVED WASTES

Waste materials generated during field investigation will include:

- Drill cuttings (soil) derived from well installation
- Decontamination fluids
- Monitoring well development and purging water
- Used personal protective equipment.

These wastes will be contained, labeled, and handled in the following manner:

- All soil cuttings will be containerized in 55-gal drums pending interpretation of analytical results. Composite samples will be collected from the containerized material to determine disposal options for investigation-derived waste. Sampling will be conducted for hazardous waste characterization of the investigation-derived waste by the Toxicity Characteristic Leachate Procedure, an extraction procedure which determines the toxicity

of the volatile organic compounds; semivolatile organic compounds; Resource Conservation and Recovery Act metals; herbicides/pesticides; and ignitability, reactivity, (as releasable sulfide and cyanide), and corrosivity (pH in the soil).

- All liquid and decontamination fluids will be collected and contained in U.S. Department of Transportation-approved 55-gal drums. Filled drums will be dated, labeled as “non-hazardous,” and temporarily stored at an onsite staging area. Disposal options for the well development and purging fluids will be based on results of the analytical sampling program.
- All used personal protective equipment will be double-bagged and disposed offsite as general refuse.

3.11 LOCATION SURVEYING

Major features of the landfill, the new 8 monitoring well locations, and the designated surface water sampling locations will be surveyed. At each monitoring well location, the ground surface elevation, along with the top of the metal casing and top of the inner polyvinyl chloride casing, will be surveyed. The surveyor will mark the inner polyvinyl chloride casing with a black marker to designate the point on the casing which has been surveyed. This mark will act as a reference point during the well gauging events. Surveying will be completed to provide as-built information for the landfill closure project and will be performed by a State of New York Licensed Land Surveyor.

4. SAMPLING FREQUENCY AND DATA REPORTING

4.1 SAMPLING FREQUENCY

Sampling and testing of the monitoring wells and the designated surface water locations will be performed on quarterly basis beginning immediately once the landfill closure activities have ceased and the new monitoring system is installed.

4.1.1 Ground-Water Sampling

The new ground-water monitoring wells at the site (MW-1B through MW-8B) will be sampled and analyzed for two rounds of baseline parameters. The first round of baseline parameter sampling will take place during the fourth quarter of 2000 (between October and December 2000), assuming the closure and well installation activities are complete. The second round of baseline parameter sampling will be conducted in the Spring 2001. The initial baseline parameter sampling results will be evaluated and a modified parameter list will be developed in conjunction with the NYSDEC Division of Environmental Remediation and Division of Solid and Hazardous Materials Region 9 Office. The ground-water monitoring points at the facility will continue to be sampled and analyzed for a selected parameters list on a quarterly basis. This quarterly sampling schedule will take place for a maximum initial period of 5 years. During the first 5-year period, the analytical ground-water quality results will be evaluated and, in conjunction with the NYSDEC Division of Environmental Remediation and Division of Solid and Hazardous Materials Region 9 Office, a more appropriate monitoring frequency and monitoring plan will be developed for the site. The selected parameter list for the ground-water monitoring program will also be re-evaluated during the initial 5-year sampling period.

As the ground water beneath the Witmer Road Landfill has been sampled and analyzed for the past 20 years, there is currently a modified parameter list. The 8 existing monitoring wells at the site will be sampled for the following parameters:

- pH
- Specific conductivity
- Total dissolved solids
- Chemical oxygen demand
- Total organic carbon
- Barium
- Hexavalent chromium
- Total chromium
- Iron
- Manganese
- Silica
- Zinc.

Of the above list, metals are currently analyzed and reported in both the total and soluble phase concentrations. The new ground-water monitoring program may include these parameters (listed above); however, additional parameters may be added on the basis of the results of the two rounds of baseline parameter sampling.

4.1.2 Surface Water Sampling

The designated surface water sampling point (SS-1) will be sampled on a quarterly basis at the site. During the sampling event, any surface water present in the drainage ditch exiting the site will be sampled and analyzed for the following parameters:

- pH
- Specific conductivity
- Total dissolved solids
- Chemical oxygen demand
- Total organic carbon
- Barium
- Hexavalent chromium
- Total chromium
- Iron
- Manganese
- Silica
- Zinc.

The samples will be analyzed and reported for both the total and soluble phase concentrations. The parameter list detailed above would be modified accordingly in the event the initial routine ground-water sampling indicated additional constituents of concern.

4.2 DATA REPORTING

The results of the two rounds of baseline parameter ground-water sampling and the subsequent quarterly site ground-water and surface monitoring will consist of the field data sheets, chain-of-custody forms, and the laboratory analysis results. Results will be sent to NYSDEC Division of Solid and Hazardous Materials Region 9 and the BOC Group. A New York State certified laboratory will be retained to analyze the ground-water and surface water samples. The laboratory will be determined prior to commencement of field activities associated with the fourth quarterly sampling event for 2000.

The results from the first two quarterly sampling events will be summarized in a letter report detailing the findings of the baseline sampling. This letter report will outline the revised parameter list recommended for future sampling events.

An annual report will be prepared that will summarize the analytical results and discuss the notable changes and trends in the ground-water and surface water quality which have occurred throughout the year. This annual report will also be sent to NYSDEC Division of Solid and Hazardous Materials Region 9.

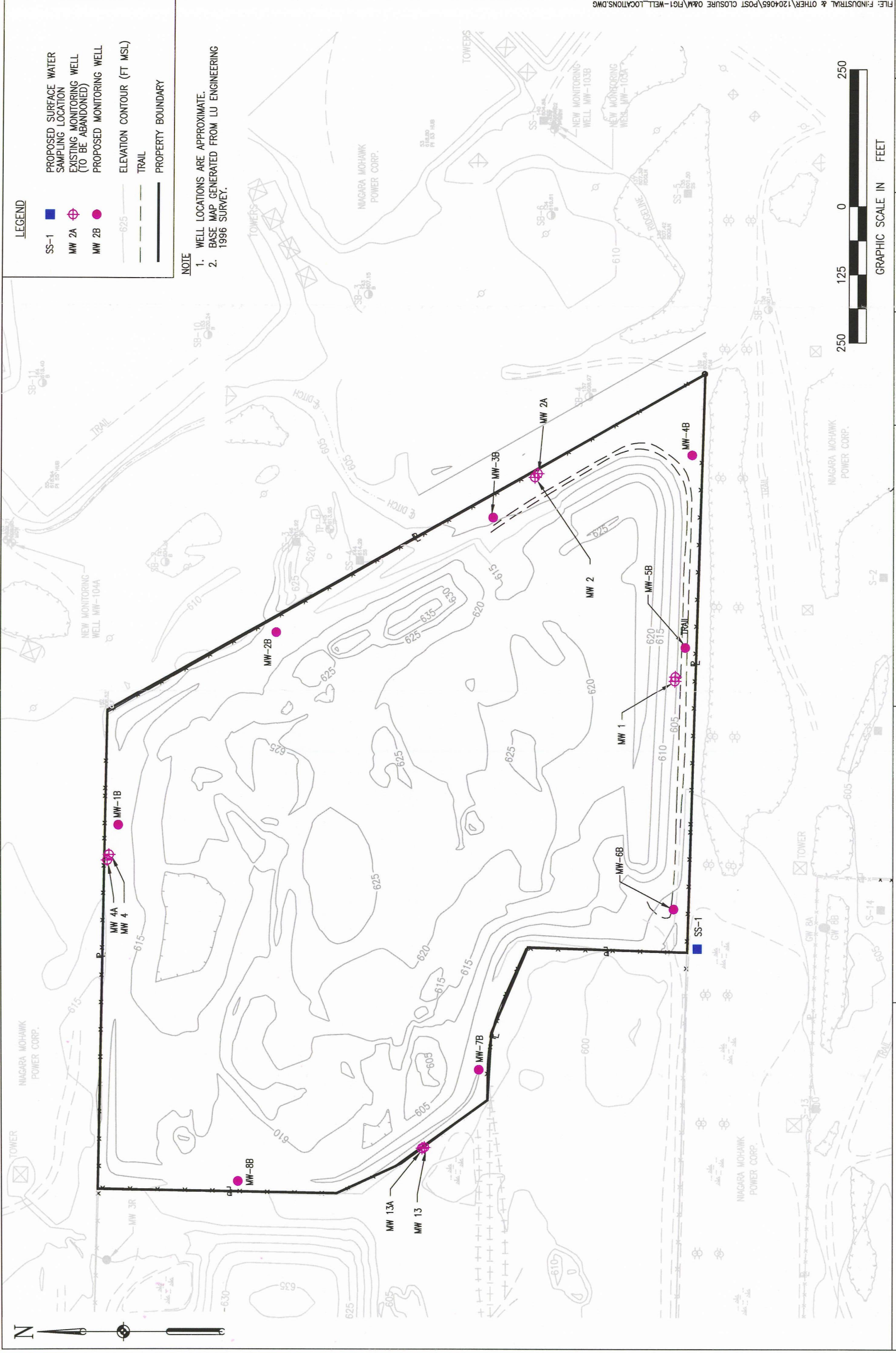

LEGEND

- SS-1 ■ PROPOSED SURFACE WATER SAMPLING LOCATION
- MW 2A ⊕ EXISTING MONITORING WELL (TO BE ABANDONED)
- MW 2B ● PROPOSED MONITORING WELL
- 625 — ELEVATION CONTOUR (FT MSL)
- - - TRAIL
- — — PROPERTY BOUNDARY

NOTE

1. WELL LOCATIONS ARE APPROXIMATE.
2. BASE MAP GENERATED FROM LU ENGINEERING 1996 SURVEY.

 EA ENGINEERING, SCIENCE, AND TECHNOLOGY	WITMER ROAD LANDFILL DESIGN-BUILD SITE CLOSURE NIAGARA FALLS, NEW YORK		FIGURE 1 WATER QUALITY SAMPLING LOCATION MAP		DESIGNED BY MJC	DRAWN BY JBS	DATE 03-21-00	PROJECT NO. 12040.65
			CHECKED BY PAP	PROJECT MGR. CEM	SCALE AS SHOWN			FIGURE 1

FILE: F:\INDUSTRIAL & OTHER\1204065\POST CLOSURE 02\M\FIG1-WELL LOCATIONS.DWG

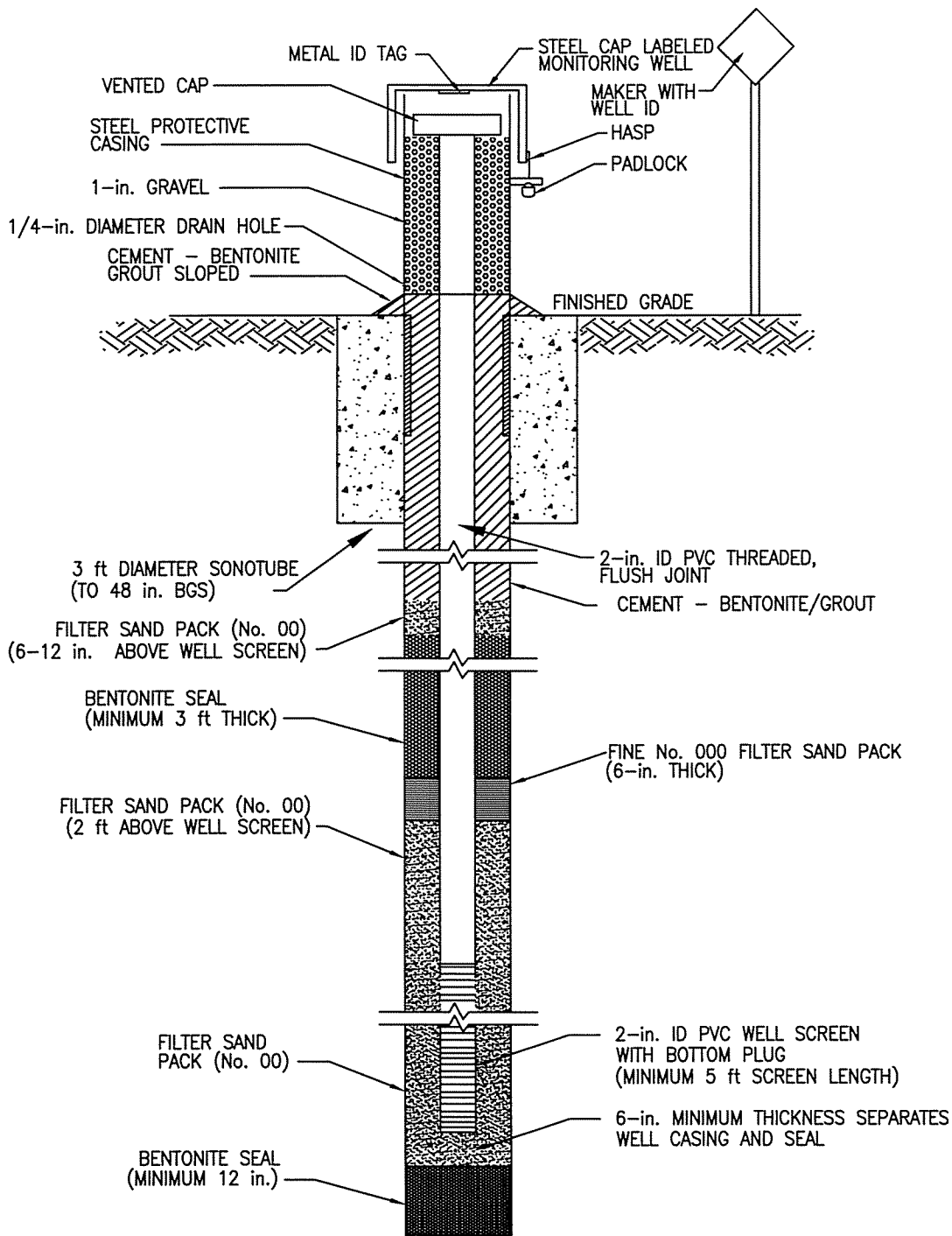

MONITORING WELL SECTION
N.T.S.

FILE: F:\INDUSTRIAL\OTHERS\BOC CASES\1204085\POST CLOSURE O&M\FIG2-WELL DIAGRAM-REV1.DWG

EA® EA ENGINEERING,
SCIENCE, AND
TECHNOLOGY

WITMER ROAD LANDFILL
DESIGN-BUILD SITE CLOSURE
NIAGARA FALLS, NEW YORK

FIGURE 2
OVERBURDEN MONITORING WELL
CONSTRUCTION DIAGRAM

PROJECT MGR CEM	DESIGNED BY GMC	DRAWN BY BT	CHECKED BY GMC	SCALE NONE	DATE 14 MARCH 2000	PROJECT NO 12040.33	FIGURE 2
--------------------	--------------------	----------------	-------------------	---------------	-----------------------	------------------------	-------------

TABLE 1 SUMMARY OF ANALYTICAL METHODS, REPORTING LIMITS, AND STANDARDS FOR BASELINE PARAMETERS FOR GROUND-WATER SAMPLES COLLECTED AT WITMER ROAD LANDFILL, NIAGARA FALLS, NEW YORK

Parameter	Suggested Laboratory Method	Project Reporting Limit ^(a)	NYSDEC Ground-Water Standards for GA Classified Waters ^(b)
VOLATILE ORGANIC COMPOUNDS ($\mu\text{g/L}$)			
Acetone	8260B	5	50
Acrylonitrile	8260B	5	5
Benzene	8260B	1	1
Bromochloromethane	8260B	1	5
Bromodichloromethane	8260B	1	50
Bromoform	8260B	1	50
Carbon disulfide	8260B	1	---
Carbon tetrachloride	8260B	1	---
Chlorobenzene	8260B	1	5
Chloroethane	8260B	1	5
Chloroform	8260B	1	7
Dibromochloromethane	8260B	1	5
1,2-Dibromo-3-chloropropane	8260B	25	0.04
1,2-Dibromoethane	8260B	1	5
1,2-Dichloropropane	8260B	1	1
<i>cis</i> -1,3-Dichloropropene	8260B	1	<0.4 ^(c)
<i>trans</i> -1,3-dichloropropene	8260B	1	<0.4 ^(c)
0-Dichlorobenzene	8260B	1	3
<i>p</i> -Dichlorobenzene	8260B	1	3
<i>trans</i> -1,4-Dichloro-2-butene	8260B	5	5
1,1-Dichloroethane	8260B	1	5
1,2-Dichloroethane	8260B	1	0.6
1,1-Dichloroethene	8260B	1	5
1,2-Dichloroethene Total	8260B	1	5
1,2-Dichloropropene	8260B	1	1
Ethylbenzene	8260B	1	5
2-Hexanone	8260B	5	50
Iodomethane	8260B	5	5
Bromomethane	8260B	1	5
Chloromethane	8260B	1	---
Dibromomethane	8260B	1	5
(a) Project Reporting Limit is either the laboratory Reporting Limit or Method Detection Limit determined according to 40 CFR 136.			
(b) NYSDEC standards for GA classified waters taken from NYCRR Title 6, Chapter X, Parts 700-705.			
(c) This value represents the sum of <i>cis</i> and <i>trans</i> isomers.			
NOTE: NYSDEC = New York State Department of Environmental Conservation. Dashes (---) indicate no standards applicable.			

Parameter	Suggested Laboratory Method	Project Reporting Limit ^(a)	NYSDEC Ground-Water Standards for GA Classified Waters ^(b)
VOLATILE ORGANIC COMPOUNDS ($\mu\text{g/L}$) (Continued)			
Dichloromethane	8260B	1	5
2-Butanone	8260B	5	---
Methyl isobutyl ketone	8260B	5	---
Styrene	8260B	1	5
1,1,1,2-Tetrachloroethane	8260B	1	5
1,1,2,2-Tetrachloroethane	8260B	1	5
Trichlorofluoromethane	8260B	1	5
Tetrachloroethene	8260B	1	5
Toluene	8260B	1	5
1,1,1, Trichloroethane	8260B	1	5
1,1,2 Trichloroethane	8260B	1	1
Trichloroethene	8260B	1	5
1,2,3-Trichloropropane	8260B	1	0.04
Vinyl acetate	8260B	1	---
Vinyl chloride	8260B	1	2
Xylenes	8260B	1	5
INORGANIC COMPOUNDS ($\mu\text{g/L}$)			
Aluminum	6010B	10	100
Antimony	6010B	3.4	3
Arsenic	6010B	2.6	25
Barium	6010B	20	1,000
Beryllium	6010B	3	3
Cadmium	6010B	0.4	5
Calcium	6010B	40	---
Chromium	6010B	0.5	50
Chromium (Hexavalent)	3500-CRB	0.4	50
Cobalt	6010B	70	---
Copper	6010B	60	200
Cyanide	4500-CNE	200	200
Iron	6010B	100	300
Lead	6010B	1.5	300
Magnesium	6010B	4	35,000
Manganese	6010B	40	300
Mercury	7470	0.2	0.7
Nickel	6010B	1.1	100
Potassium	6010B	40	---
Selenium	270.2	1.6	10
Silver	6010B	1.6	50
Sodium	6010B	8	20,000
Thallium	6010B	2.3	0.5
Vanadium	6010B	80	---
Zinc	6010B	20	2,000

Parameter	Suggested Laboratory Method	Project Reporting Limit ^(a)	NYSDEC Ground-Water Standards for GA Classified Waters ^(b)
LEACHATE INDICATORS			
Total Kjeldahl Nitrogen	LAC 107-06-2D	1.0	---
Ammonia	4500-NH3E	1.0	2,000
Nitrate	LAC 107-04-1	0.2	10,000
Chemical Oxygen Demand	HACH 8000	10	---
Biochemical Oxygen Demand	5210B	2.0	---
Total Organic Carbon	5310B	1.0	---
Total Dissolved Solids	160.1	2.0	---
Sulfate	375.4	5.0	250,000
Alkalinity	2320B	3.8	---
Phenols	LAC 210-00-1	0.01	1
Chloride	4500-CLB	5.0	250,000
Bromide	300	1.0	2,000
Total hardness as CaCO ₃	6010B	2.0	---
Color	110.1	2.5	---
Boron	6010B	50	1,000
FIELD PARAMETERS ($\mu\text{g/L}$)			
Eh	---	---	---
Dissolved Oxygen	---	---	---
Turbidity	---	---	---
pH	---	---	---
Specific Conductance	---	---	---

TABLE 2 SUMMARY OF SAMPLE CONTAINERS, PRESERVATION TECHNIQUES, AND HOLDING TIMES FOR GROUND-WATER SAMPLES COLLECTED AT WITMER ROAD LANDFILL, NIAGARA FALLS, NEW YORK

Suggested Laboratory Method	Sample Holding Time	Sample Preservation (cool to 4°C+/-2°C)	Type and Number of Containers ^(a)
<i>Volatile Organic Compounds –</i> Method 8260B	14 days	HCl	3, 40-ml glass
<i>Inorganic Compounds –</i> Method 6010B	6 months	HNO ₃	1-L Plastic
Method 3500-CRB	24 hours	None	1-L Plastic
Method 4500-CNE	14 days	NaOH	1-L Plastic
Method 7470	28 days	HNO ₃	1-L Plastic
Method 270.2	6 months	HNO ₃	1-L Plastic
<i>Leachate Indicators –</i> Method LAC 107-06-2D	28 days	H ₂ SO ₄	1-L Glass ^(b)
Method 4500-NH3E	28 days	H ₂ SO ₄	1-L Glass ^(b)
Method LAC 107-04-1	28 days	H ₂ SO ₄	1-L Glass ^(b)
Method HACH 8000	28 days	H ₂ SO ₄	1-L Glass ^(b)
Method 5210B	48 hours	None	1-L Plastic
Method 5310B	28 days	H ₂ SO ₄	2, 40-ml glass
Method 160.1	7 days	None	1-L Plastic
Method 375.4	28 days	None	1-L Plastic
Method 2320B	14 days	None	1-L Plastic
Method LAC 210-00-1	28 days	H ₂ SO ₄	1-L Amber Glass
Method 4500-CLB	28 days	None	1-L Plastic
Method 300 (Br)	28 days	None	1-L Plastic
Method 200.7	6 months	HNO ₃	1-L Plastic
Method 110.1	48 hours	None	1-L plastic
<i>Additional Parameters –</i> Method 9040	Immediate	None	Field Analysis
Method 9050	28 days	None	1-L Plastic
Method 410.1	28 days	H ₂ SO ₄	1-L Glass ^(b)
Method 5310B	28 days	H ₂ SO ₄	2, 40-ml glass
(a) All containers must have Teflon-lined lids.			
(b) Multiple analysis can be completed utilizing (one) sample container.			

Attachment A

Field Forms

- A.1 Soil Boring Log**
- A.2 Field Record of Monitoring Well Construction**
- A.3 Field Record of Well Development**
- A.4 Field Record of Well Gauging, Purging, and Sampling**
- A.5 Landfill Cap Inspection Checklist**

Attachment A.1

Soil Boring Log



EA Engineering,
Science, and
Technology, Inc.

LOG OF SOIL BORING

Co-ordinates: _____

Surface Elevation: _____

Casing Above Surface: _____

Reference Elevation: _____

Reference Description: _____

Job No. _____ Client _____

Location _____

Drilling Method: _____

Boring No. _____

Sampling Method: _____

Sheet _____ of _____
Drilling

Water Level _____

Time _____

Date _____

Reference _____

Start Time _____

Finish Time _____

Date _____

Surface Conditions: _____

Drilling Contractor: _____

Driller: _____

Lic. No. _____

By: _____

Date: _____

Checked By: _____

Sampler Type	Inches		Depth of Casing	Sample No	Sample Depth	blows/s in Sampler	Depth in Feet	USCS Log	Surface Conditions
	Driven	Recovered							
							0		
							1		
							2		
							3		
							4		
							5		
							6		
							7		
							8		
							9		
							0		
							1		
							2		
							3		
							4		
							5		
							6		
							7		
							8		
							9		
							0		

Attachment A.2

**Field Record of Monitoring
Well Construction**

FIELD RECORD OF MONITORING WELL CONSTRUCTION

(ALL MEASUREMENTS FROM GROUND SURFACE)

SIT NAME/LOCATION:			PROJECT:
DATE INSTALLED:	STARTED:	COMPLETED:	LOCATION: (COORDINATES OR STATION)
ELEVATION TOP OF BORING:			SIGNATURE OF INSPECTOR:
ELEVATION TOP OF CASING:			HOLE No. (AS SHOWN ON DRAWING TITLE AND FILE No.)
DEPTH TO WATER:			DATE/TIME:
DRILLING METHOD:			

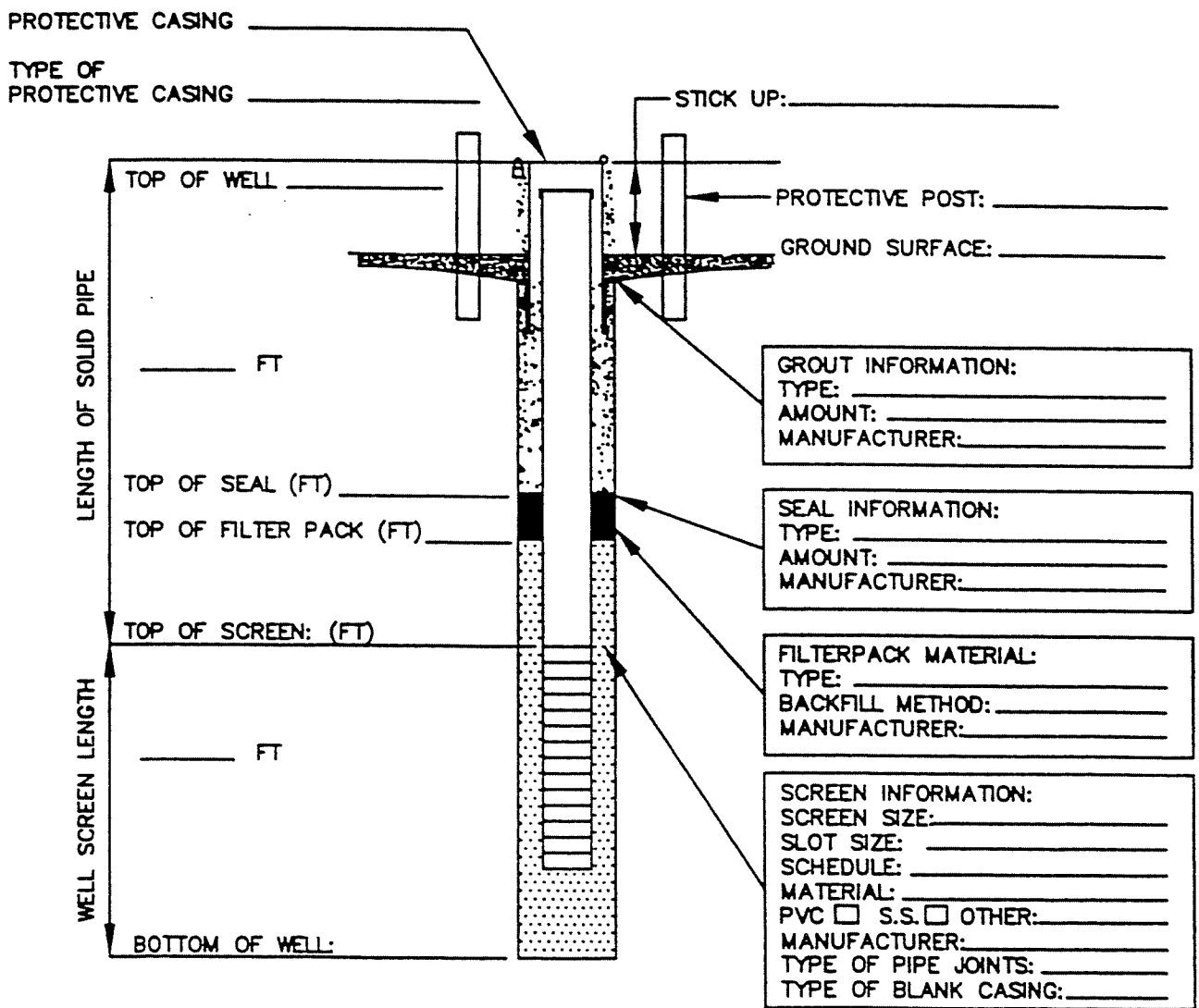

FIGURE --- FIELD RECORD OF MONITORING WELL CONSTRUCTION

Attachment A.3

**Field Record of
Well Development**



FIELD RECORD OF WELL DEVELOPMENT

Project Name:	Project No:	Date:
EA Personnel:	Development Method:	
Weather/Temperature/Barometric Pressure:		Time:

Well No.:	Well Condition:
Well Diameter:	Measurement Reference:
Well Volume Calculations	
A. Depth To Water (ft):	D. Well Volume/ft:
B. Total Well Depth (ft):	E. Total Well Volume (gal)[C*D]:
C. Water Column Height (ft):	F. Five Well Volumes (gal):

Parameter	Beginning	1 Volume	2 Volumes	3 Volumes	4 Volumes	5 Volumes
Time (min)						
Depth to Water (ft)						
Purge Rate (gpm)						
Volume Purged (gal)						
pH						
Temperature (°C)						
Conductivity (µmhos/cm)						
Dissolved Oxygen						
Turbidity						
Parameter	6 Volumes	7 Volumes	8 Volumes	9 Volumes	10 Volumes	End
Time (min)						
Depth to Water (ft)						
Purge Rate (gpm)						
Volume Purged (gal)						
pH						
Temperature (°C)						
Conductivity (µmhos/cm)						
Dissolved Oxygen						
Turbidity						

COMMENTS AND OBSERVATIONS: _____

Attachment A.4

Field Record of Well Gauging, Purging, and Sampling

FIELD RECORD OF WELL GAUGING, PURGING, AND SAMPLING

Project Name:	Project No.:	Date:
EA Personnel:	Purge Method:	
Weather/Temperature/Barometric Pressure:		Time:

Well No.:	Well Condition:
Well Diameter:	Measurement Reference:
Well Volume Calculations	
A. Depth to Water (ft):	D. Well Volume/ft:
B. Total Well Depth (ft):	E. Total Well Volume (gal) [C*D]:
C. Water Column Height (ft):	F. Five Well Volumes (gal):

Parameter	Beginning	1 Volume	2 Volumes	3 Volumes	4 Volumes	5 Volumes
Time (minutes)						
Depth to Water (ft)						
Purge Rate (gpm)						
Volume Purged (gal)						
pH						
Temperature (°C)						
Conductivity (μmhos/cm)						
Dissolved Oxygen (mg/L)						
eH (mV)						
TOTAL QUANTITY OF WATER REMOVED (gal): _____						
COMMENTS AND OBSERVATIONS: _____						

Attachment A.5

Landfill Cap Inspection Checklist

**LANDFILL CAP INSPECTION CHECKLIST
WITMER ROAD LANDFILL, NIAGARA FALLS, NEW YORK**

EA Personnel:

Date:

Weather:

1. Inspection of ground surface for exposure of geotextile cover (cap erosion):
2. Inspection of ground surface for differential settlement resulting in soil cracking or ponded water:
3. Identification of stressed vegetation:
4. Identification of seeps, rooted vegetation (trees), and/or animal burrows:
5. Identification of deteriorating equipment (i.e., monitoring wells, fencing, or drainage structures):
6. Inspection of stormwater drainage swales for erosion, sloughing, or flow-through:
7. Inspection of east side of the landfill (Niagara Mohawk Power Corporation parcel) along the intermittent stream for the presence of erosion or sloughing:
8. Inspection of access roads:

Attachment B

Standard Operating Procedures for Low Flow and Sampling Method

ATTACHMENT B

STANDARD OPERATING PROCEDURES FOR LOW FLOW AND SAMPLING METHOD

B.1 SCOPE OF APPLICATION

The purpose of this Standard Operating Procedure is to establish the protocol for collecting ground-water samples with minimum turbidity, and is also intended to be used in conjunction with the analyses for the most common types of ground-water contaminants (semivolatile organic compounds and inorganic compounds).

B.2 EQUIPMENT/MATERIALS

- Operations and Maintenance Plan.
- Well construction data and location map.
- Field logbook and Field Record of Well Gauging, Purging, and Sampling forms.
- Water level measuring device, 0.01 ft accuracy (electronic preferred) for monitoring water level during pumping operations.
- Pumps: adjustable rate, variable displacement submersible centrifugal pumps constructed of stainless steel and Teflon[®] or peristaltic pump.
- Tubing: Teflon or Teflon-lined polyethylene must be used to collect samples for organic analysis. For samples collected for inorganic analysis, Teflon or Teflon-lined polyethylene, polyvinyl chloride, Tygon, or polyethylene tubing may be used.
- Flow measurement supplies (e.g., graduated container and stopwatch).
- Power source (e.g., generator).
- Water quality indicator parameter monitoring instruments—pH, turbidity, specific conductances, temperature, oxidation-reduction potential, and dissolved oxygen. Water quality indicator parameters will be measured in the field in accordance with U.S. Environmental Protection Agency (EPA)-600/4-79-020 (1983) using the following methods: temperature (Method 170.1), pH (Method 150.1), turbidity (Method 180.1), specific conductance (Method 120.1), and dissolved oxygen (Method 360.1).
- Decontamination supplies (for monitoring instruments).

- Sample bottles and sample preservation supplies (as required by the analytical method).
- Sample tags or labels.

B.3 PRELIMINARY ACTIVITIES

The following site activities are required prior to performing well purging and ground-water sampling. Field logbooks and sampling forms should be filled out as the procedure is being performed, as noted:

- Enter the following information in the field logbook and sampling form, as appropriate: site name, project number, field personnel, well identification, weather conditions, date and time, equipment used, and quality assurance/quality control data for field instrumentation.
- Check well for damage or evidence of tampering; record pertinent observations in field logbook and on sample form.
- Lay out sheet of polyethylene for monitoring and sampling equipment.
- Unlock well and remove well cap (if applicable).
- If the well casing does not have a reference point (usually a v-cut or indelible mark in the well casing), make one.
- Measure and record the height of the protective casing above the concrete pad or ground surface, as appropriate. This reading is compared to that recorded during well installation as an indication of possible well damage or settling that may have occurred.
- Measure and record the depth to water (to 0.01 ft) in each well to be sampled before purging begins. Care should be taken to minimize disturbance of any particulate attached to the side or at the bottom of the well. The depth to well bottom should not be measured because of the potential to stir up sediment at the bottom of the well.

B.4 SAMPLING PROCEDURE

The following general procedure will be followed to obtain representative ground-water samples. Field logbooks and sampling forms should be filled out as the procedure is being performed, as noted:

- Enter the following information in the field logbook and sampling form, as appropriate, prior to purging: purge date and time, purge method, and depth to water.

- Prepare the pump by checking electrical connections, discharge tubing, and motor. Locate the generator (if applicable) downwind of the well; connect the power converter to the generator.
- Connect the instrumentation header to the pump discharge and begin purging the well at 0.2-0.5 L/minute. Measure and record the water level and time with the pump in well before starting the pump. Continue pumping the well at 0.2-0.5 L/minute.
- Establish that the water level has not dropped significantly such that the pump is dry (bubbles in discharge) or water is heard cascading down the inside of the well. This may be accomplished by setting the sensor of the water level meter approximately 3-6 in. below the static water level and monitoring for a continuous audible alarm, which indicates the sensor is in water and the level has not dropped more than 6 in. Ideally, the pump rate should cause little or no water level drawdown in the well (>0.5 ft and the water level should stabilize). The water level should be monitored every 3-5 minutes (or as appropriate) during pumping. Care should be taken not to cause entrainment of air in the pump system. Record pumping rate adjustments and depths to water. Pumping rates should, if needed, be reduced to the minimum capabilities of the pump (e.g., 0.1-0.2 L/minute) to avoid pumping the well dry and/or to ensure stabilization of indicator parameters. The well will not be purged dry as this may affect analytical parameters.
- During purging of the well, monitor the water quality indicator parameters (turbidity, temperature, specific conductance, and pH) every 3-5 minutes. Record in the field logbook and on the Field Record of Well Gauging, Purging, and Sampling the pumping rate, drawdown, water quality indicator parameters values, and clock time at 3- to 5-minute intervals in the field logbook and sampling record. Purging of the standing well water is considered complete when three consecutive readings of the water quality indicator parameters agree within approximately 10 percent. Turbidity readings consistently below 10 nephelometric turbidity units (NTU) are considered to represent stabilization of discharge water for this parameter. If the parameters have stabilized, but the turbidity is not in the range of the 10 NTU goal, the pump flow rate should be decreased and measurement of the parameters should continue every 3-5 minutes. Measurements should be obtained using a flow-through cell.
- Reduce the pump flow rate to the lowest practical setting, usually about 0.1 L/minute. Remove the in-line sensor, if applicable. If the water discharged by the pump is silty, wait for the water to clear before sampling. Ensure that bubbles are not observed in the discharge tubing. Record pertinent observations in the field logbook and on sampling records.

- Begin filling sample containers from the pump discharge, allowing the water to fill the containers by allowing the pump discharge to flow gently down the inside of the container with as little agitation or aeration as possible. Collect the sample aliquots for the analytical parameter categories in the order below, as applicable:
 - Volatile organic compounds
 - Metals
 - All other analytes.

- Complete remaining portions of Field Record of Well Gauging, Purging, and Sampling Form after each well is sampled, including sample team members, sample date and time, total quantity of water removed, well sampling sequence and time of sample collection, types of sample bottles used, sample identification numbers, preservatives used, parameters requested for analysis, and field observations of sampling event.

Appendix B

Construction Quality Assurance and Construction Quality Control Plan

**Construction Quality Assurance and
Construction Quality Control Plan for the
Witmer Road Landfill
Niagara Falls, New York**

Prepared for

The BOC Group
100 Mountain Avenue
Murray Hill, New Jersey 07974

Prepared by

EA Engineering, P.C. and Its Affiliate
EA Engineering, Science, and Technology
3 Washington Center
Newburgh, New York 12550
(914) 565-8100

April 2000
Revision: FINAL
Project No. 12040.65

**Construction Quality Assurance and
Construction Quality Control Plan for the
Witmer Road Landfill
Niagara Falls, New York**

Prepared for

The BOC Group
100 Mountain Avenue
Murray Hill, New Jersey 07974

Prepared by

EA Engineering, P.C. and Its Affiliate
EA Engineering, Science, and Technology
3 Washington Center
Newburgh, New York



20 April 2000

David S. Santoro, P.E., L.S.
President, EA Engineering, P.C.

Date

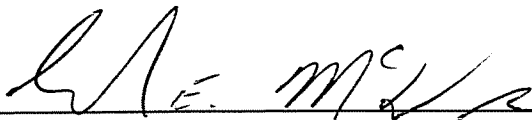

20 April 2000

Charles E. McLeod, Jr., P.E.
Project Manager/Program Manager
EA Engineering, Science, and Technology

Date

April 2000
Revision: FINAL
Project No. 12040.65

CONTENTS

	<u>Page</u>
LIST OF FIGURES	
LIST OF TABLES	
1. INTRODUCTION	1
1.1 Statement of Purpose	1
1.2 Organization.....	1
2. PROJECT MANAGEMENT/MEETINGS	2
2.1 Roles and Responsibilities	2
2.1.1 Contractor’s Project Manager	2
2.1.2 Resident Engineer	2
2.1.3 Contractor’s Construction Manager	3
2.1.4 Chief Surveyor	3
2.1.4.1 Survey Crew	3
2.2 Organizational Chart for Quality Assurance.....	4
2.3 Communication Lines.....	4
2.4 Pre-Construction Meeting.....	4
2.5 Progress Meetings.....	5
2.6 Problem/Deficiency Meetings.....	5
2.7 Pre-Final and Final Inspection Meeting.....	6
3. OPERATIONAL PLAN.....	7
3.1 Mobilization.....	7
3.2 Erosion Control and Stormwater Management Facilities.....	7
3.3 Clearing and Grubbing.....	7
3.4 Subgrade Preparation and Bedding Layer Installation.....	7
3.5 Liner Installation.....	7
3.6 Geocomposite Drainage Layer Installation.....	8
3.7 Barrier Protection Layer Installation.....	8
3.8 Topsoil	8
3.9 Seeding.....	8
3.10 Fencing.....	8
3.11 Restoration of Borrow Area.....	8

	<u>Page</u>
4. CONSTRUCTION QUALITY ASSURANCE/CONSTRUCTION QUALITY CONTROL TRAINING, CERTIFICATIONS, AND TESTING REQUIREMENTS	9
4.1 Independent Testing Laboratories.....	9
4.2 Present Qualifications and Certifications	9
4.3 Other Testing Qualifications.....	9
4.4 Natural Material Construction Quality Assurance/Construction Quality Control Testing Requirements and Natural Material Quality Assurance Testing Requirements	10
4.4.1 Natural Material Construction Quality Assurance/Construction Quality Control and Natural Quality Assurance	10
4.4.2 Materials	10
4.4.3 Construction Evaluation	11
4.4.3.1 General	11
4.4.3.2 General Fill.....	11
4.4.3.3 Construction Quality Control Testing	12
4.4.3.4 Vegetative Support and Topsoil Layers	12
4.4.3.5 Seeding and Mulching.....	13
4.4.3.6 Deficiencies	13
4.4.3.7 Notification.....	13
4.4.3.8 Repairs and Retesting.....	13
4.4.3.9 Acceptance	14
4.4.4 Trenching, Backfilling, and Compaction.....	14
4.4.5 Stormwater Control.....	14
4.4.5.1 Materials.....	14
4.4.6 Dust Control.....	15
4.5 Geosynthetics Construction Quality Assurance/Construction Quality Control Testing Requirements	15
4.5.1 Geosynthetics Manufacturing and Delivery.....	15
4.5.1.1 Manufacturing	15
4.5.1.2 Manufacturer’s Construction Quality Control Testing.....	16
4.5.1.3 Shipment, Storage, and Handling.....	17

	<u>Page</u>
4.5.2 Cap Installation	18
4.5.2.1 Surface Acceptance	18
4.5.2.2 Geomembrane Panel Layout Plan	18
4.5.2.3 Accepted Seaming Methods	20
4.5.2.4 Nondestructive Seam Testing.....	21
4.5.2.5 Destructive Seam Testing.....	22
4.5.2.6 Defects and Repairs.....	24
4.5.3 Geocomposite Installation and Construction	25
5. SURVEYING CONSTRUCTION QUALITY ASSURANCE.....	27
5.1 Introduction.....	27
5.2 Survey Control.....	27
5.3 Precision and Accuracy.....	27
5.4 Required Activities	27
5.5 Frequency and Spacing	28
5.6 Documentation.....	28
6. DOCUMENTATION	29
6.1 Daily Quality Control Report.....	29
6.2 Progress Report.....	30
6.3 Testing Data Sheets	30
6.4 Photographic Record.....	31
6.5 Design and/or Specification Changes	31
6.6 Record/As-Built Drawings.....	31
6.7 Final Certification and Summary Report.....	32

ATTACHMENT A: QUALITY ASSURANCE FORMS

LIST OF FIGURES

<u>Number</u>	<u>Title</u>
1	Quality assurance information flow chart.

LIST OF TABLES

<u>Number</u>	<u>Title</u>
1	Natural material quality assurance testing for the Witmer Road Landfill Design-Build Site Closure, Niagara Falls, New York.
2	Geosynthetic material quality assurance testing for the Witmer Road Landfill Design-Build Site Closure, Niagara Falls, New York.

1. INTRODUCTION

1.1 STATEMENT OF PURPOSE

This Construction Quality Assurance and Construction Quality Control (CQA/CQC) Plan has been prepared for the Witmer Road Landfill parcel in Niagara Falls, New York. This plan describes the necessary materials testing required under 6 NYCRR Part 360-2.8 and 2.13(j) and (k) and associated subparts. The purpose of this document is to specify the means of assuring construction quality.

The activities that will require specific quality assurance (QA) procedures for the landfill closure construction include the following:

- Erosion control and stormwater management
- Site grading/waste relocation
- Bedding layer installation
- Geosynthetic liner installation
- Barrier protection installation
- Topsoil installation.

The project construction and installation will require verification of specified materials, assurance of material placement, and laboratory and field testing of in-place materials to verify both compliance with project plans and specifications and good workmanship.

1.2 ORGANIZATION

Section 1 outlines the purpose of this CQA/CQC Plan, and identifies applicable regulatory provisions. Section 2 includes a discussion of the responsibilities and authorities for the CQA/CQC management organization and also addresses pre-construction meetings, progress meetings, problem/deficiency meetings, and pre-final and final inspection meetings. Section 3 describes the operational plan to include mobilization, erosion control, stormwater management facilities, clearing and grubbing, subgrade preparation, bedding layer installation, liner installation, geocomposite drainage layer installation, barrier protection, topsoil, seeding, fencing, and restoration of the borrow area. Section 4 identifies CQA/CQC training, certifications, and testing requirements. Section 5 addresses surveying construction QA. Section 6 summarizes project close-out documentation requirements.

2. PROJECT MANAGEMENT/MEETINGS

The construction of the landfill closure at Witmer Road will require coordinated efforts of many individuals to successfully meet the landfill closure requirements of 6 NYCRR Part 360. Those efforts include inspections, testing, and submittal review of materials to be used in the landfill closure construction. A suggested structural organization to provide support to the individuals performing the required QA activities is discussed below. The actual landfill closure contractor may have different names for the following individuals, but the general intent should closely resemble what is presented below.

2.1 ROLES AND RESPONSIBILITIES

Specific project roles will be established for the successful completion of this project. The following presents those project roles and a brief description of their anticipated responsibilities.

2.1.1 Contractor's Project Manager

The Contractor's Project Manager provides overall project coordination of field efforts and home office efforts. Overall project performance responsibilities include the staffing management, ensuring safe work conduct, meeting schedule requirements, subcontract management, billing and other accounting efforts, and reporting to the New York State Department of Environmental Conservation (NYSDEC) Regional Office. The Project Manager provides the NYSDEC Regional Office Representative with a primary contact for project and contractual issues.

2.1.2 Resident Engineer

Landfill closure activities at Witmer Road Landfill will be conducted under the direction of a Resident Engineer. A Resident Project Representative may be designated by the Resident Engineer for the purposes of being present at the site. For the purposes of this CQA/CQC Plan, the Resident Engineer and the Resident Project Representative will be considered one and the same.

The role of Resident Engineer is to provide verification that landfill closure activities and the specified standards of quality are being met. Several functions of the Resident Engineer are:

- Verifying that specified testing procedures are conducted consistently and in the prescribed manner
- Confirming that testing equipment is functioning properly and is regularly calibrated
- Documenting that materials and construction activities are performed in accordance with the project specifications

- Confirming that test data are properly recorded and interpreted
- Recommending to the NYSDEC Regional Office Representative which work should be accepted
- Documentation of construction progress and CQA performance.

The Resident Engineer must work very closely with the NYSDEC Regional Office Representative to document that project quality standards are consistently being achieved, but without undue duplication of effort. Clear lines of authority and responsibility must be made known to all parties before the construction begins.

2.1.3 Contractor's Construction Manager

The Construction Manager provides the Project Manager with onsite, day-to-day coordination of the field activities. Included in the Construction Manager's responsibilities are:

- Planning/executing daily work efforts
- Scheduling and coordinating subcontractors and material suppliers
- Daily safe work conduct
- Adherence of the work with the contract documents
- Daily tracking of budget and schedule
- Timely and efficient implementation of the construction.

The Construction Manager will be in daily contact with the Project Manager to ensure a continual line of communication. The Construction Manager provides the Resident Engineer with an onsite contact for field-related issues.

2.1.4 Chief Surveyor

The Chief Surveyor is employed by the Contractor and has the responsibility for the overall surveying requirements for the project. He/she will be a land surveyor registered in the State of New York. All surveying work will be performed under the direct supervision of the Chief Surveyor.

2.1.4.1 Survey Crew

The survey crew will consist of the Chief Surveyor, and as many crew members as is required to satisfactorily perform the work. All surveying personnel will be experienced in surveying similar sites, including detailed accurate documentation.

2.2 ORGANIZATIONAL CHART FOR QUALITY ASSURANCE

The Contractor will provide to the Resident Engineer an organizational structure that supports successful project completion in chart format. Project positions described above will be presented showing the lines of authority.

2.3 COMMUNICATION LINES

Daily construction communication, whether to written report logs or verbally to project personnel, is of paramount importance to the quality of this project. By observing and verifying the daily subcontractor construction performance, the Construction Manager will enact the QA procedures noted in the contract documents at the specified frequencies. Figure 1 presents how the information describing the construction performance moves from the field crews to the Project Manager and ultimately to the Resident Engineer and the NYSDEC Regional Office Representative.

Daily meetings that include the Resident Engineer, Construction Manager, and the field crew will highlight the type and number of QA tests required for the day's activities. QA procedures in the specifications direct the Construction Manager on how and when to test individual materials, and that information is disseminated during the daily meetings. As the construction is performed, the result is recorded on either the Daily Logs or a specific Testing Log as appropriate. Daily Logs and Testing Logs are directed to the Project Manager who checks the logs for possible construction defects. As the information is sent to the Resident Engineer from the Project Manager, the Resident Engineer's involvement in construction performance will become an important part of the project's progress. The Resident Engineer will review test results for verification and documentation. The Construction Manager and the Project Manager will have continuous communication links on a nearly daily basis, as will the NYSDEC Regional Office Representative and the Resident Engineer.

2.4 PRE-CONSTRUCTION MEETING

A pre-construction meeting will be held at the site. At a minimum, the meeting will be attended by the NYSDEC Regional Office Representative, Resident Engineer, Contractor's Project Manager, Contractor's Construction Manager, and major subcontractors.

Topics considered for this meeting include:

- Identification of appropriate modifications to the CQA/CQC Plan
- Review of responsibilities of each party
- Review of lines of authority and communication

- Review of methods for distributing and storing documents and reports
- Review of methods for documenting and reporting inspection data and procedures for handling construction deficiencies, repairs, and retesting
- Review of the Site-Specific Health and Safety Plan
- Review of site security protocols
- Review of testing and sampling requirements for construction materials
- Outline of procedures for packaging and storing geosynthetics archive samples
- Review of schedule for construction
- A site walk-around, and review of material protection, storage, and stockpiling locations
- Review of methods of material(s) placement
- Review of testing requirements for soil components.

The meeting will be documented (by a person designated at the beginning of the meeting) and the minutes will be distributed to all parties in attendance.

2.5 PROGRESS MEETINGS

Monthly progress meetings will be held at the site, unless more frequent meetings are necessary. The Project Manager or Construction Manager, Resident Engineer, and Contractor will attend (and others as appropriate). These meetings will include discussions regarding current progress, planned activities, and any new business or revisions. The Resident Engineer will document problems, decisions, and questions arising at this meeting. Any matter(s) requiring action will be reported to the appropriate parties. The general discussions in these meetings can be reported in the Contractor's daily reports. Specific problems/questions will be addressed in separate correspondence.

2.6 PROBLEM/DEFICIENCY MEETINGS

A meeting will be held when a problem or deficiency is present or likely to occur. At a minimum, the meeting will be attended by the NYSDEC Regional Office Representative and the Resident Engineer. The Contractor should also attend, if appropriate. If a problem requires a design modification, the Design Engineer should also be present. The purpose of the meeting is to define and resolve the problem or deficiency as follows:

- Define and discuss the problem or deficiency
- Review solutions
- Prepare a recommendation to the NYSDEC Regional Office Representative to implement a plan to address the problem or deficiency.

The meeting will be documented by the Resident Engineer.

2.7 PRE-FINAL AND FINAL INSPECTION MEETING

The Resident Engineer will conduct meetings after both the pre-final and final inspections. The meeting after the pre-final inspection will assist in documenting any unfinished construction items and deficiencies for inclusion in the pre-final inspection report. A meeting scheduled after the final inspection will assist in documenting that all unfinished construction items and deficiencies have been addressed. This documentation will be included in the construction completion report.

The meeting will be documented by the Resident Engineer. The meeting minutes will be distributed to all parties in attendance and filed in the appropriate project files.

3. OPERATIONAL PLAN

The successful outcome of the landfill closure for the Witmer Road project will depend on a logical sequencing of operations. This section presents a suggested sequencing that has been developed to accomplish the different activities that must be performed. The actual landfill closure Contractor may have a sequence of operations which varies from what is presented below. Such information of events will be submitted to the Resident Engineer for review and approval at the pre-construction meeting.

3.1 MOBILIZATION

This activity describes assembling the manpower and tools necessary to perform the project work. Initial forces required to establish the work site will move onto designated areas providing an established field headquarters for the project. Temporary office and supply trailers are moved to the project site and become resident for the project duration. As the work progresses, other temporary facilities or equipment are moved to the project site as required.

3.2 EROSION CONTROL AND STORMWATER MANAGEMENT FACILITIES

Erosion and sediment control measures will be installed at the Contractor-supplied offsite borrow source and the landfill work site as per the contract documents. This work will be according to the contract documents and may include the placement of berms, silt fencing, stabilized construction entrances, sediment traps, super silt fencing, and hay bale dikes to mitigate the effects of rain runoff. Efforts to de-water specific work areas may be initiated at this time, if necessary.

3.3 CLEARING AND GRUBBING

Crews will clear and remove vegetation material from the soil borrow source area and other project areas as required. Crews will remove and dispose of material as per the specifications.

3.4 SUBGRADE PREPARATION AND BEDDING LAYER INSTALLATION

In preparation for installation of the liner system, the Contractor will perform waste relocation and general site grading as indicated on the contract drawings. The Contractor will also supply and install the bedding layer over the regraded waste to the grades shown on the drawings.

3.5 LINER INSTALLATION

Crews will install a 40-mil linear, very flexible polyethylene liner according to the approved panel layout plan. Installation personnel will test, inspect, and collect samples to maintain the project requirements according to specifications.

3.6 GEOCOMPOSITE DRAINAGE LAYER INSTALLATION

Crews will install a geocomposite drainage layer according to the contract documents and specifications. Installation personnel will test, inspect, and collect samples to maintain the project requirements according to specifications.

3.7 BARRIER PROTECTION LAYER INSTALLATION

Work crews will take soil from the offsite borrow source and place the material on the geocomposite drainage layer. The Contractor will be responsible for procurement of this source of borrow material; such a site will not be specified by the contract documents, but soil from the borrow site must comply with the specifications. The soil will be placed in one 12-in. lift (compacted thickness). Personnel will compact the cover material according to the contract requirements. Samples will be collected to ensure that the material has the correct moisture content and that compaction efforts meet the contract design requirements.

3.8 TOPSOIL

The Contractor will supply topsoil from a borrow source outside the site and place the topsoil over the barrier protection layer. This final component is a 6-in. placement performed in a single lift. The topsoil surface will be tested to ensure that it meets the contract requirements, and that the surface is prepared for seeding according to the specifications.

3.9 SEEDING

After correct topsoil surface preparation, the Contractor will apply the specified seed mixtures to the landfill cap. Areas that were disturbed during construction and were specified in the project design will also receive the appropriate seeding application. Areas specified to receive wetlands-type mixtures will be seeded.

3.10 FENCING

The fencing contractor will install the perimeter fence in accordance with the contract documents.

3.11 RESTORATION OF BORROW AREA

Grading crews will finish grading the offsite borrow site after requirements for borrow material are completed. Finish contours will promote adequate area drainage. The finish grading activities include the surface preparation and hydroseed application. Restoration of the borrow site by the Contractor will conform to all federal, state, and local requirements.

4. CONSTRUCTION QUALITY ASSURANCE/CONSTRUCTION QUALITY CONTROL TRAINING, CERTIFICATIONS, AND TESTING REQUIREMENTS

4.1 INDEPENDENT TESTING LABORATORIES

Independent testing laboratories will be subcontracted by the Contractor to perform materials testing as a part of the CQA/CQC program. Materials that will require independent verification of physical properties include:

- General fill material/bedding layer soil
- Very flexible polyethylene membrane
- Geocomposite
- Geotextiles
- Barrier protection layer
- Topsoil
- Drainage swale clay (1×10^{-7} cm/sec)
- General fill
- Stone.

4.2 PRESENT QUALIFICATIONS AND CERTIFICATIONS

Testing laboratory qualifications, including verification of demonstrated knowledge, will be furnished to the Resident Engineer prior to commencement of work with the materials in question. After materials have been placed and samples taken, the certified testing results of physical properties will be presented to the Resident Engineer for approval. The testing will be certified to ensure that it was completed according to the requirements in the design plan and this CQA/CQC Plan. Testing and result reporting will be performed according to the project schedule.

4.3 OTHER TESTING QUALIFICATIONS

The person or persons who collect material samples for physical properties testing must have demonstrated knowledge of the pertinent testing procedure, and must be approved by the Contractor's Construction Manager and the Project Manager. This approval will include documentation of the technician's qualifications. The Contractor's QA Officer retains responsibility for the technician's qualifications.

4.4 NATURAL MATERIAL CONSTRUCTION QUALITY ASSURANCE/ CONSTRUCTION QUALITY CONTROL TESTING REQUIREMENTS AND NATURAL MATERIAL QUALITY ASSURANCE TESTING REQUIREMENTS

This subsection addresses the construction QA testing for natural materials for the Witmer Road Landfill closure.

The primary means of implementing this CQA/CQC Plan will be by observations made at the site, with sample testing providing proof of material and installation quality. The Construction Manager is responsible for assuring that the work is completed according to the contract documents. Materials that will receive CQA testing during construction include:

- Bedding layer soil
- Barrier protection layer soil
- Topsoil
- Drainage swale clay
- General fill
- Stone.

4.4.1 Natural Material Construction Quality Assurance/Construction Quality Control and Natural Material Quality Assurance

The Construction Manager will perform or direct the performance by qualified subcontractors of testing the natural materials. The sample collection and testing will be performed at the direction and frequency shown in the specifications and as shown in Table 1.

The individual performing the testing or the testing oversight will have demonstrated knowledge in the pertinent testing procedure, and will be approved in writing by the Contractor's Project Manager. This written approval will include documentation of the technician's qualifications. Test results will be submitted to the Resident Engineer when available.

4.4.2 Materials

The soil materials include general earth fill, bedding soil, vegetative support soil, and topsoil. Other natural materials to undergo CQA testing include stone, sand, and road gravel. The Resident Engineer will observe all materials for consistency with the approved samples. Any materials appearing to deviate from the approved samples will be retested by the Contractor to verify their compliance with the project specifications.

4.4.3 Construction Evaluation

4.4.3.1 General

The Resident Engineer will document and observe the construction activity. The responsibilities of the Resident Engineer include the following:

- Monitor removal and disposal of cleared vegetation and preparation of subgrade
- Review source(s) and conformance testing of construction materials
- Evaluate and document bedding layer placement, 18-in. vegetative support layer placement, and topsoil layer placement
- Evaluate stockpiling activities
- Evaluate completed soil components for proper elevation(s) and condition
- Evaluate/confirm that the equipment and procedures used to place soil layers have not damaged geosynthetic material(s) and that repair(s), if necessary, are made in a timely manner
- Evaluate the installation of the geosynthetic components
- Inform the NYSDEC Regional Office Representative in the event that materials, placement, and/or testing do not meet project specification requirements.

4.4.3.2 General Fill

The Contractor is responsible for the CQC testing of the various soil components. The Contractor is responsible for providing a surface suitable for placement of the geomembrane and meeting the requirements for surface acceptance.

General fill may be used in the following locations:

- 6-in. bedding layer for placement of geosynthetics
- 12-in. barrier protection layer.

During construction, the general fill placement will be observed to confirm that its characteristics are equivalent to those required in the technical specifications. Nonconforming characteristics will be identified and repaired.

4.4.3.3 Construction Quality Control Testing

Laboratory and field CQA tests will be performed by the Contractor in accordance with the project specifications, as listed below:

Test	Method
Gradation Analysis	ASTM D-422
Atterberg Limits	ASTM D-423
Moisture Density	ASTM D-698
Moisture Content of Soil	ASTM D-2216
In-Place Density-Nuclear Density Method	ASTM D-2922
NOTE: ASTM = American Society of Testing and Materials.	

The Resident Engineer will observe the CQA testing in the field and review all test results from both laboratory and field testing. He/she will confirm that the test results of the earthwork construction meet or exceed requirements outlined in the project technical specifications.

Nuclear density methods will be performed in accordance with the technical specifications and ASTM Method 2922 for all density testing due to the ease of testing and the large number of tests that can be run in a specified time. All nuclear gauges used on this project will be required to have been calibrated within the past 12 months. Standard counts for density and moisture will be taken on a daily basis. Questions concerning the accuracy of any single test will be addressed by retesting in the vicinity of the original test. Additional testing will be used at the discretion of the Resident Engineer when visual observations indicate a problem. Additional testing will be considered when:

- Lift thickness is greater than specified
- Earthfill is at improper and/or variable moisture content
- Pumping of soil is encountered during compaction
- Characteristics of the soil change.

During construction, the frequency of testing may be increased in the following situations:

- Adverse weather conditions
- Breakdown of equipment
- At the start and finish of grading
- Materials fail to meet specifications.

4.4.3.4 Vegetative Support and Topsoil Layers

The Resident Engineer will observe the placement of the 6-in. topsoil layer for consistency of quality and thickness. The Resident Engineer will confirm the final elevations of the topsoil layer are within the requirements of the project. The final elevations (top of topsoil) will be provided by the Chief Surveyor. The Contractor will verify the in-place thickness of the

vegetative support and topsoil layers by taking depth checks at the rate of four per acre of material placed. Care will be taken to ensure that the lining system is not damaged while making depth checks of the vegetative support layer. Any damage to the lining system will be immediately repaired.

4.4.3.5 Seeding and Mulching

It is necessary that the topsoil layer be covered with vegetation at the earliest possible time to stabilize the cover system and prevent erosion. A seeding subcontractor to the landfill closure Contractor may be used for this work.

The Resident Engineer will observe the seeding process to confirm that the soil is properly prepared and the seed mixtures are as specified in the technical specifications. He/she will confirm the tilling depth and the application rate of additives, rate of seed and mulch application, amount of uniformity of coverage and consistency, and methods of watering. Seeded areas will be observed for bare spots.

The CQA Officer will ensure that the seeding and mulching work is performed when weather conditions are favorable.

4.4.3.6 Deficiencies

If a deficiency is discovered in the earthworks, the Resident Engineer, together with the Construction Manager, will immediately determine the extent and nature of the deficiency. If the deficiency is indicated by an unsatisfactory test result, the Resident Engineer will determine the extent of the deficient area by additional tests, observations, records review, or other appropriate methods.

4.4.3.7 Notification

After determining the extent and nature of a deficiency, the Resident Engineer will notify the NYSDEC Regional Office Representative and the landfill closure Contractor and schedule appropriate retesting after the deficiency is corrected.

4.4.3.8 Repairs and Retesting

The landfill closure Contractor will correct the deficiency to the satisfaction of the Resident Engineer. If a requirement cannot be met, or unusual weather conditions hinder work, then the Resident Engineer may suggest solutions to the NYSDEC Regional Office Representative and the landfill closure Contractor to obtain acceptance.

All retests performed by the landfill closure Contractor must confirm that the deficiency has been corrected before any additional work is performed in the area of the deficiency. The Resident

Engineer will confirm that installation requirements are met and that CQC submittals are provided.

4.4.3.9 Acceptance

The Resident Engineer will recommend to the NYSDEC Regional Office Representative acceptance of the work performed by the landfill closure Contractor when soil components are completed in accordance with the project specifications.

4.4.4 Trenching, Backfilling, and Compaction

Trench excavation will be open cut from ground surface and located as shown on the construction drawings. Trenches will be excavated to depths as shown on construction drawings and will be adequately drained to prevent ponding of water. The trenches will be backfilled as outlined in the specification; and if the trench is associated with the installation of the geosynthetic components, care will be taken to avoid damage to the geosynthetics.

The Resident Engineer will observe the trenching, backfilling, and compaction for compliance with the project specifications and will report any noncompliance to the NYSDEC Regional Office Representative.

4.4.5 Stormwater Control

The landfill closure Contractor will be responsible for the excavation and construction of the drainage channels and the sediment ponds and berms to the lines and grade requirements of the project drawings and specifications. The Resident Engineer will observe the excavation for compliance to the specification and immediately prior to placement of any geosynthetic material(s) in order to confirm acceptability of finished surface to receive the geosynthetic material.

4.4.5.1 Materials

Geotextile

Materials used will be in accordance with the technical specifications. The geotextile will be placed as outlined in Section 4.5 of this CQA/CQC Plan. The geotextile overlaps will be shingled downslope in the direction of stormwater flow.

Riprap

Materials used will be in accordance with the technical specifications. The riprap will be placed in one operation to the specified thickness. The riprap will be placed in such a manner so as not

to damage the geotextile. The riprap will be placed to avoid clusters of large stones, small stones, and voids.

The Resident Engineer will observe the placement of materials for compliance with the specifications and report any noncompliance to the NYSDEC Regional Office Representative.

4.4.6 Dust Control

The release of dust from the site will be controlled by water spray on temporary access and haul roads and the work areas. Dust generation is expected to be more prevalent during dry weather. It is the landfill closure Contractor's responsibility to maintain control of the dust and comply with the community air monitoring plan and NYSDEC Technical Air Guidance Memorandum as outlined in the Closure Plan.

4.5 GEOSYNTHETICS CONSTRUCTION QUALITY ASSURANCE/CONSTRUCTION QUALITY CONTROL TESTING REQUIREMENTS

This subsection addresses the geosynthetic QA testing for the Witmer Road Landfill closure.

Geomembranes are the key components of the lining system, and no geomembrane requirements should be compromised in any way. The manufacturer will be responsible for supplying the specified material. The Contractor's Project Manager and the Construction Manager are responsible for the review of this material and the determination that the specification requirements have been met. Certifications from the manufacturer will be included in the final project documentation. The Construction Manager is responsible for observing and verifying that the geotextile, geocomposite, and liner, and their installation proceed, according to the requirements of the specifications and in accordance with Table 2.

Geosynthetic items that will receive testing during construction include:

- Geomembrane (manufacturer's CQC testing and supplemental CQA testing)
- Geotextiles (manufacturer's CQC testing)
- Geocomposite drainage layers (manufacturer's CQC testing).

4.5.1 Geosynthetics Manufacturing and Delivery

4.5.1.1 Manufacturing

The Resident Engineer will confirm that the geosynthetics meet the project specifications requirements. The Resident Engineer will examine manufacturer('s) product data, affidavits, and certifications supplied by the installer and will visually inspect the delivered materials.

The Resident Engineer will **confirm** that:

- Material property values are certified by the manufacturer that they meet or exceed all of the requirements given in the project specifications.
- Measurements of properties by the manufacturer are properly documented and that the test methods used are acceptable.
- The CQC certificates are provided at the required frequency and that each certificate identifies the specific rolls sampled.

Rolls

Prior to shipment, the Contractor will provide the Resident Engineer with the CQC certificates from the manufacturer(s). The CQC certificates will be signed by a responsible party employed by the manufacturer, such as the production manager. The CQC certificates will include:

- Manufacturer's name, location, and date of production.
- Roll number(s) and identification.
- Sampling procedures, test methods, and results of CQC tests. At a minimum, results will be given in accordance with the test methods outlined in the project specifications.
- Other requirements listed in the specifications.

4.5.1.2 Manufacturer's Construction Quality Control Testing

Prior to delivery of the geomembrane, the manufacturer will provide CQC certificates for the following tests based on a frequency of one test per every second roll or one test per 100,000 ft² produced, whichever is more frequent:

Test	Method
Tear resistance	ASTM D-1004
Low temperature brittleness	ASTM D-746M
Water extraction	ASTM D-570
Thickness	ASTM D-1593
Tensile strengths and elongation	ASTM D-638
Volatility	ASTM D-1203
Dimensional stability	ASTM D-1204
Friction angle ^(a)	ASTM D-5321
(a) Two tests required, between 40 mil linear low density polyethylene and geocomposite, and between the geocomposite and the borrow soil.	

Prior to delivery of the geotextile, the manufacturer will provide CQC certificates for the geotextile based on a frequency of one test per every production run/5,000 yd², whichever is more frequent:

Test	Method
Tensile strength and elongation	ASTM D-4595
Trapezoidal tear strength	ASTM D-4533
Mullen burst strength	ASTM D-3786
Puncture strength	ASTM D-4833
Apparent opening size	ASTM D-4751
Ultraviolet resistance	ASTM D-4355

Prior to delivery of the geocomposite, the manufacturer will provide CQC certificates for the geocomposite based on a frequency as stated in Specification Section 02373:

Test	Method
Geocomposite transmissivity	ASTM D-4716-95
Geonet only:	
Thickness	ASTM D-5199
Tensile strength (machine direction)	ASTM D-4595
Geotextile only:	
Grab tensile	ASTM D-4632
Puncture strength	ASTM D-4833
Angle of strength	ASTM D-4751
Flow rate	ASTM D-4491

4.5.1.3 Shipment, Storage, and Handling

Shipping of the geosynthetics are the responsibility of the manufacturer(s). Handling onsite is the responsibility of the landfill closure Contractor.

The Resident Engineer will verify that handling equipment and personnel used do not pose any risk of damage to the geosynthetics.

Upon delivery, the installer and the Resident Engineer will observe all rolls for defects and damage. These observations will be conducted without unrolling rolls unless defects or damages are found or suspected. The Resident Engineer will report the following to the NYSDEC Regional Office Representative:

- Rolls which should be rejected and removed from the site because they have severe flaws
- Rolls which include minor, repairable flaws which would not affect the performance of the material.

Storage

The landfill closure Contractor will be responsible for the storage of the geosynthetics. The Resident Engineer will identify storage space in a location(s) such that site transportation and handling are minimized. Geosynthetics will be stored in a manner that protects the product from ultraviolet degradation and other physical and environmental damage.

The Resident Engineer will confirm that the geosynthetics are protected against dirt, impact, theft, vandalism, and traffic.

4.5.2 Cap Installation

4.5.2.1 Surface Acceptance

Before the geomembrane and geocomposite drainage layer placement begins, the following will take place:

- On a daily basis the Resident Engineer and landfill closure Contractor will observe that the completed bedding layer surface remains in the condition required by the project specifications. The installer will provide the Resident Engineer with a written letter of acceptance that the surface is acceptable for cap section installation.

4.5.2.2 Geomembrane Panel Layout Plan

The landfill closure Contractor will provide a panel layout plan as required by the specifications. The Resident Engineer will review the plan and confirm that the seams shown are located as follows:

- Oriented parallel to the line of maximum slope, i.e., oriented along, not across, the slope
- All horizontal seams are staggered
- In corners and odd-shaped locations, the number of seams are minimized
- Horizontal seams are greater than 5 ft from the toe of the slope or areas of potential stress concentrations.

Panel Nomenclature

A panel is the section of geomembrane that is placed and seamed in the field. The landfill closure Contractor will give each panel a specific and logical identification code consistent with the panel layout plan.

Installation Weather Conditions

The geomembrane placement will not be considered should the weather conditions not permit seaming following placement. Geomembrane placement will not be permitted during rain, in the presence of moisture (e.g., fog, dew), in an area of ponded water, or during excessive winds.

In addition, the geomembrane will not be placed at ambient temperatures below 32°F or above 120°F, during periods of precipitation, or when winds are in excess of 20 mi per hour.

Method of Development

The landfill closure Contractor will ensure the handling equipment used will not damage the geomembrane material and the following:

- The surface underlying the geomembrane (geocomposite) has not been damaged or deteriorated.
- Unfolding the panels does not cause unacceptable damage to the geomembrane.
- Placement of the geomembrane panel minimizes wrinkles and waves.
- Ballasting or anchoring of the panel will not damage the geomembrane and will prevent uplift by wind. In case of high winds, the placement of geomembrane will be discontinued.
- Contact with the geomembrane is minimized, and the geomembrane is protected by suitable materials.
- Geomembrane placed in a working day will be welded on the same day.
- Personnel do not smoke while working on the geomembrane.

Damage and Defects

The Resident Engineer and landfill closure Contractor will observe each placed panel prior to seaming for damage and/or defects. The Resident Engineer will document which panels, or portions of panels, should be rejected, repaired, or accepted. Damaged panels, or portions of damaged panels, that have been rejected will be marked and removed from the work area. Repairs are to be made using procedures outlined in this subsection.

4.5.2.3 Accepted Seaming Methods

Fusion welding is the preferred method for field seaming.

Fusion Process

The landfill closure Contractor will log ambient temperature, weather conditions (wind, rain), and seaming apparatus information at appropriate intervals. The landfill closure Contractor will ensure that:

- For cross seam, the edge of the cross seam is ground to an incline prior to welding.
- As required, a movable protective layer is used below each area to be seamed as it prevents build-up of moisture between the panels and prevents debris from collecting around the pressure rollers.
- The geomembrane panels are aligned to have a minimum overlap of 6 in. and will be sufficient for peel tests.
- Spare operable seaming apparatus are maintained onsite.
- Seaming will not damage the geomembrane.
- The electric generator is placed on a protective base.

Seam Preparation

The landfill closure Contractor will ensure that the seam area is clean and free of moisture, dust, dirt, debris, or foreign material of any kind.

General Seaming Procedures

During seaming, the landfill closure Contractor must comply with the following:

- Fishmouths or wrinkles will be cut along the top, laid flat, and seamed or patched.
- Seaming will extend to the outside edge of panels placed in any anchor trench.

Seaming Weather Conditions

The required weather conditions for seaming are as follows:

- Dry conditions (i.e., no precipitation or other excessive moisture, such as fog or dew)
- Ambient temperature is between 32°F and 120°F, unless otherwise approved
- Winds are not excessive (i.e., greater than 20 mi per hour sustained wind speed).

Trial Seams

The landfill closure Contractor will make trial seams on pieces of geomembrane to confirm that conditions are suitable for seaming. The project engineer will certify that trial seams are made at the start of each work day for each seaming crew, after every 4 hours of continuous seaming, every time seaming equipment is changed, or when significant changes in geomembrane temperature are observed.

The trial sample will be at least 3 ft long \times 1 ft wide with seams centered lengthwise. Five random test strips will be cut from the sample and peel tested using a field tensiometer that is capable of a jaw separation rate of approximately 2 in./minute.

Three of four trial seam samples must pass the minimum values noted below:

Test	Value	Method
Bond Seam Strength	Film Tear Bond and 40 lb/in. (both smooth and textured)	ASTM D 3083
Peel Adhesion	Film Tear Bond and 30 lb/in. (textured)	ASTM D 413
	Film Tear Bond and 35 lb/in. (smooth)	

Trial Seam Failure Procedure

The trial seam test sample must meet the above requirements before failure of the seam. For peel adhesion, the seam separation will not extend more than 10 percent into the seam. If a specimen fails, the entire operation will be repeated. If additional failures occur, the equipment will be removed from service and repaired and retested, or the material will be rejected.

4.5.2.4 Nondestructive Seam Testing

Concept

Nondestructive seam testing checks the continuity of seams. Nondestructive testing will be carried out as the seaming work progresses. The landfill closure Contractor will nondestructively test all field seams over the full length of the seam, using the methods described in Specification Section 02372.

For all seams, the landfill closure Contractor will carry out nondestructive testing procedures and record location, data, test unit number, name of tester, and outcome of all testing.

4.5.2.5 Destructive Seam Testing

Destructive Seam Testing

Destructive seam testing is used to determine and evaluate seam strength. This testing includes:

- **Individual Seams**—At the beginning and the completion of a seam, a 1-in. wide strip sample, cut across the seam by the landfill closure Contractor, is removed from each location and field tested. These test samples should, if possible, be removed from a location that would not require repairing. If the test fails, other samples should be taken along the seam and tested. If these samples fail, destructive test failure procedures apply for repair of the seam and the seaming unit will be checked and a successful trial seam performed before the unit can be used for seaming.
- **Laboratory Test Sample**—The laboratory test sample locations are selected by the Resident Engineer at a minimum frequency of one sample per every 500 ft of seam length seamed by the individual performing the seaming. The landfill closure Contractor will not be informed in advance of the locations from which the samples are to be taken.

Laboratory Test Sampling

The laboratory test samples will be cut by the landfill closure Contractor at the locations selected by the Resident Engineer as seaming progresses in order to have test results before the geomembrane is to be covered. All holes resulting from destructive seam sampling will be immediately repaired in accordance with approved repair and testing procedures outlined in this CQA/CQC Plan. The Resident Engineer will:

- Select sample locations
- Observe sample cutting by the landfill closure Contractor
- Assign a number to each sample and mark it accordingly on the sample and on the geomembrane adjacent to the sample locations
- Record sample location on the geomembrane repair data sheet
- Record reason for taking sample (i.e., suspicion, routine).

Size of Sample

The procedures for obtaining the samples are provided in detail in Specification Section 02372:

- The test section will be cut into three parts and distributed as follows:
 - One portion for CQA/CQC testing, 12 in. × 16 in.
 - One portion to installer, 12 in. × 16 in.
 - One portion for archive storage, 12 in. × 16 in.

Field Testing

The 1-in. wide strip samples will be tested by electrically operated tensiometer with a jaw separation rate of 2 in. per minute, for peel and shear tests. If failure occurs, destructive test failure procedures will apply.

The Resident Engineer will witness field tests and, as required, mark all samples and portions with their number, document the sampled locations, date and time, ambient temperature, seaming unit number, seamers initials, seam number, and field test result.

Resident Engineer Test Procedures

Additional samples may be tested by an independent testing laboratory. Tests will include seam strength and peel adhesion (ASTM D-3083 and D-413, respectively).

For shear tests, the sheet will yield before failure of the seam. For peel adhesion, seam separation will not extend more than 10 percent into the seam. For either test, testing will be discontinued when the sample has visually yielded.

The minimum acceptable values for seam peel adhesion and shear strength tests are presented below. Four specimens will be cut with a 1-in. die from the test seam. Specimens will be selected alternately from the samples (i.e., peel, shear, peel, shear) for laboratory testing.

Three of four samples must pass for the minimum values noted below:

Test	Value	Method
Bonded Seam Strength: Minimum (4 replications)	Film Tear Bond and 40 lb/in. (both smooth and textured)	ASTM D-3083
Peel Adhesions: Fusion (4 replications)	Film Tear Bond and 30 lb/in. (textured) Film Tear Bond and 35 lb/in. (smooth)	ASTM D-413

Destructive Test Failure

The following will apply whenever a laboratory sample or field test strip fails:

- The landfill closure Contractor can reconstruct the seam between any two locations which were previously tested and accepted and retest.
- The landfill closure Contractor can trace the seam in both directions to locations 10 ft (minimum) from the location of the failure. Test strip samples are then taken in both locations for field-testing. If these pass, full laboratory samples are removed and tested. If the laboratory samples pass, then the seam is reconstructed, and non-destructively tested between the passing locations. If either sample fails laboratory testing, then the procedure is repeated from the location(s) of the failed sample(s).

4.5.2.6 Defects and Repairs

All seams and non-seam areas of the geomembrane will be examined by the Resident Engineer to identify defects, holes, blisters, undispersed raw materials, and any sign of contamination by foreign matter. The surface of the geomembrane seam area will be clean at the time of examination. The landfill closure Contractor will clean the geomembrane seam area if required. Each location requiring repair will be marked by the Resident Engineer and landfill closure Contractor and repaired by landfill closure Contractor.

Repair Procedures

The procedures for repairs are listed in Specification Section 02372.

Testing

Each large cap/patch will be numbered and documented. Every repair will be documented and non-destructively tested. Large caps may require destructive seam testing. The Resident Engineer may observe and document testing of repairs.

Wrinkles/Waves

Prior to placing overlying materials, the Resident Engineer will indicate which wrinkles should be cut and resealed by the landfill closure Contractor. Wrinkles should be located during the coldest part of the installation process.

Bridging

The Resident Engineer will observe areas where the geomembrane is bridging and evaluate with the landfill closure Contractor whether corrective measures are required. Corrective measures will be tested as any other repair.

Geomembrane Protection

Upon completion of an area of geomembrane (seaming, testing), access over the area will be restricted until the overlying material(s) is placed. Immediately prior to overlying material placement, the landfill closure Contractor and the Resident Engineer will observe the surface of the geomembrane for any potential damage. Any damage observed will be repaired and tested. Placement of soil materials on top of the geomembrane should take place at the coolest time of the day in order to minimize the development of waves.

4.5.3 Geocomposite Installation and Construction

The landfill closure Contractor will place geocomposites to avoid damage and to comply with the following:

- On slopes, anchor the geocomposite and roll it down the slope in such a manner as to continually keep the geocomposite sheet in tension
- Ballast all geocomposites until cover material is placed
- Cut geocomposites using a hook blade; do not damage underlying materials
- Do not entrap stones or dirt in or under the geocomposite.

Joining Procedures

No horizontal seams are allowed on side slopes unless otherwise approved. The following requirements are to be met:

- Downslope seams will be overlapped so that the geonet is in direct contact with the underlying geonet and overlaps 2-3 in.; the overlap on transverse seams will be at least 12 in.
- Geonet overlaps will be tied with colored plastic fasteners
- Tying of the geonet will be every 5 ft along the slope and every 12 in. along end-to-end seams

- Geotextile of the geocomposite will be continuously heat-bonded or sewn; the Contractor will pay particular attention at seams to ensure that no earth cover material could be inadvertently inserted beneath the geotextile
- Sewing will be double stitched using polyester thread as per the project specifications.

Defects and Repairs

The landfill closure Contractor and the Resident Engineer will locate and mark damaged areas and the landfill closure Contractor will repair these areas. The Resident Engineer will observe any repair and report any noncompliance.

If only the geotextile is damaged, a patch will be thermally bonded over the damaged area.

If the geonet is damaged, it will be removed and a geonet patch will be tied to the existing geonet and the geotextile repaired.

Should the damage be severe, as determined by the Resident Engineer, the geocomposite will be replaced.

Geocomposite Protection

Soil materials will be placed top of the geocomposites ensuring that:

- Materials are not damaged
- Slippage of the geocomposite on underlying layers is minimal
- There are no excessive stresses to the geocomposite.

5. SURVEYING CONSTRUCTION QUALITY ASSURANCE

5.1 INTRODUCTION

Surveying of lines and grades is conducted on an ongoing basis during construction of the components. Close CQA of the surveying is absolutely essential to ensure that components are properly constructed. The surveying work performed as part of the surveying QA will be part of the CQA program and is not intended to supplement or augment the Remedial Contractor's surveying for control of line and grade.

5.2 SURVEY CONTROL

Permanent benchmarks have been established for the site as shown on the drawings. The vertical and horizontal controls for the site construction activities will be based on the permanent benchmarks.

5.3 PRECISION AND ACCURACY

A wide variety of survey equipment is available to meet the requirements of this project. The survey instruments used for this work should be sufficiently precise and accurate to meet the needs of the project. All survey instruments should be capable of reading to a precision of 0.01 ft and with a setting accuracy of 20 seconds (5.6×10^{-3} degrees). Components will meet a maximum tolerance of 0.2 ft except for surface water channels where the maximum tolerance will be 0.1 ft.

5.4 REQUIRED ACTIVITIES

The following will be surveyed to verify the lines and grades and locations required by the contract documents. The survey activities should include, at a minimum:

- Initial project stake-out
- Surface of waste subgrade
- Surface of bedding layer
- Surface of barrier protection layer
- Surface of final cover (top of topsoil)
- Location survey for truck access road
- Fence stake out.

5.5 FREQUENCY AND SPACING

Surveying CQA will be carried out upon completion of a given installation to facilitate progress and avoid delaying commencement of the next installation. In addition, spot checks during construction will be necessary to assist the earthwork contractor in completing the grades.

The following spacings and locations will be provided, at a minimum, for survey points:

- Surfaces with slopes less than 10 percent will be surveyed on a square grid not wider than 100 ft with additional locations at grade breaks.
- On slopes greater than 10 percent, a square grid not wider than 100 ft will be used; in any case, a line at the crest, midpoint, and toe of the slope will be taken as well as at grade breaks.
- A line of survey points no farther than 100 ft apart will be taken along any slope break (this will include the inside edge and outside edge of any bench on a slope).

5.6 DOCUMENTATION

All field survey notes will be retained by the landfill closure Contractor's Chief Surveyor. The results from the field surveys will be documented on a set of survey record (as-built) drawings. These drawings should at least show all elevations of the surfaces surveyed.

6. DOCUMENTATION

The landfill closure construction progress at the Witmer Road Landfill will be recorded using written reports and photography. A description of the written reports and a description of the photographic activities are presented in this section.

An effective CQA/CQC Plan depends on the documentation of construction activities. The Resident Engineer will verify that CQA/CQC requirements have been addressed.

The Resident Engineer will provide the NYSDEC Regional Office Representative with signed descriptive reports, remarks, memorandums, data sheets, and checklists to confirm that monitoring, testing, and sampling activities have been completed. The Resident Engineer will maintain at the job site a complete set of project specifications, the CQA/CQC Plan, checklists, test procedures, daily logs, and other pertinent documents.

6.1 DAILY QUALITY CONTROL REPORT

The Contractor's Construction Manager will be responsible for completion of the daily construction report. This report represents the daily record of the landfill construction, and will be included in the CQA documentation submitted at project completion. A sample of a suggested daily quality control report format is provided in Attachment A. Daily reports will be submitted to the Resident Engineer on the day following the report date. At a minimum, this log will include:

- Sequencing number
- Date, project name, and location
- Weather conditions including temperature, etc.
- Meeting minutes of any formal meetings that took place during the day
- Construction locations/activities underway during the time frame of the report, including site plans of specific work areas, as appropriate
- Equipment used
- Description of work done during the day
- Location, horizontal dimensions and depth (as appropriate), and quantity of material placed

- Testing performed during the day and approximate locations of tests
- Description and quantity of any material received onsite during the day, including CQA documentation
- Data on the calibrations or recalibrations of test equipment performed during the day
- The location, description, purpose, and number of photographs taken during the day
- Any incidents of substandard quality that were made during the day, the corrective actions taken, as well as the identification number of the problem identification data sheet
- Reports of safety-related infractions or incidents
- Signature of the Construction Manager.

6.2 PROGRESS REPORTS

The Resident Engineer will prepare and submit a progress report once every 2 weeks, or at time intervals established at the pre-construction meeting, for NYSDEC review. At a minimum, this report will include the following information:

- Identifying number for cross-referencing and document control
- Date, project name, location, and other information
- Summary of work activities during progress reporting period
- Summary of construction problems or deficiencies
- Summary of weather conditions
- Brief description of activities anticipated for the next reporting period
- Signature of the Resident Engineer.

6.3 TESTING DATA SHEETS

The Construction Manager is responsible for testing data sheet oversight. The testing reports will record testing performed during the project execution. This information will be used during construction and in the compilation of the QA documentation submitted at the project completion. Although these sheets may be different according to the type of testing performed, at a minimum these sheets will include:

- Sequencing number
- Date
- Title
- Location of the test

- Description of the test, including the test method being used
- Test data with calculations, as appropriate
- Analysis of the test data
- Tester's name
- Signature of the Contractor's CQA Supervisor.

6.4 PHOTOGRAPHIC RECORD

The Contractor's Construction Manager will use digital photography necessary to record the landfill construction. The daily log will note the photographs taken. The Construction Manager will keep a photographic record log, a description of each photograph, and the date and time taken. Photographs will be kept in chronological order. Electronic copies of the photographs will be securely stored for future use. Videotape documentation may be provided at the Contractor's option and expense, but will not take the place of still photography.

All photographic records will be kept onsite and presented to and retained by the NYSDEC Regional Office Representative upon completion of the project, and will be made available to designated oversight personnel upon request during construction activities.

6.5 DESIGN AND/OR SPECIFICATION CHANGES

Design and/or specifications changes may be required during construction. In such cases, the Resident Engineer will notify the Design Engineer.

Design and/or specification changes will be made only with written agreement of the Resident Engineer and the Design Engineer, and will take the form of an addendum to the project specifications and CQA/CQC Plan.

6.6 RECORD/AS-BUILT DRAWINGS

Drawings will be prepared by the Contractor under the direction of the Resident Engineer. At a minimum, the drawings should include the following information:

- Elevation of the top of topsoil (final grade)
- Lateral extent of the cap
- Locations of existing monitoring wells, roads, pipelines, and fences
- Location and details of the earthwork construction including depths, plan dimensions, elevations, soil component thicknesses, etc.

The drawings will address each of the components and, if necessary, another drawing will identify problems or unusual conditions of the geosynthetic layers. In addition, applicable details will show constructed components that differ from the plans or specifications.

6.7 FINAL CERTIFICATION AND SUMMARY REPORT

A Interim Remedial Measure Report, as specified in the Order on Consent, will be prepared to outline the completed activities associated with the closure of the Witmer Road Landfill. The Interim Remedial Measure Report will also include the construction certifications as required under 6 NYCRR Part 360. Certifications are required to provide documentation that the project plans and specifications were met during construction. The certifications will be appended to the Interim Remedial Measure Report as required.

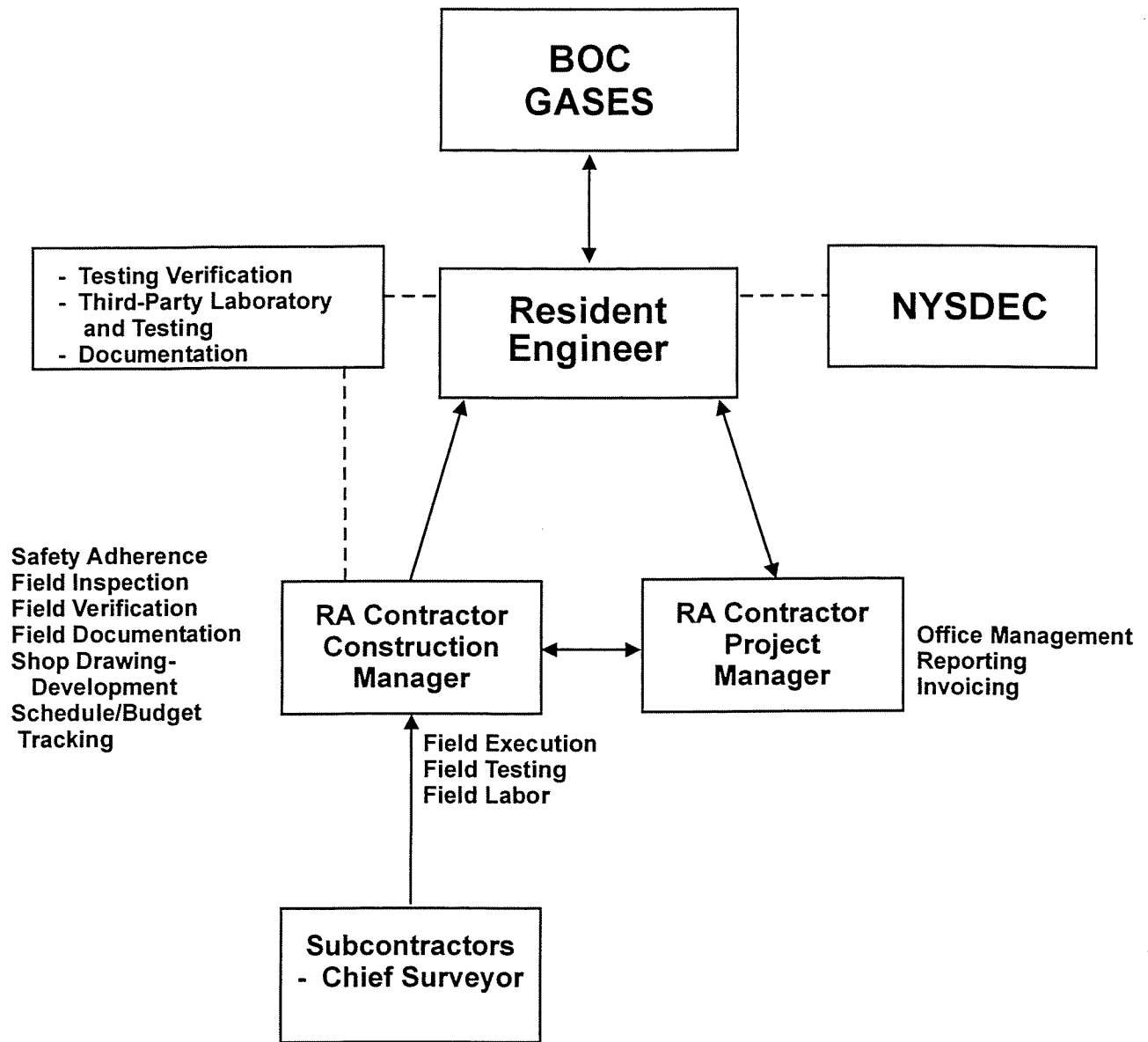

Figure 1. Quality Assurance Information Flow Chart.

TABLE 1 NATURAL MATERIAL QUALITY ASSURANCE TESTING FOR THE
WITMER ROAD LANDFILL DESIGN-BUILD SITE CLOSURE,
NIAGARA FALLS, NEW YORK

Material	Test	Test Method	Frequency
Common Borrow Fill	Target Compound List Organics	EPA Methods SW-846, 8270C, and 8260B	1 test per borrow source. ^(a)
	Target Analyte List Inorganics	EPA Methods SW-846 and 6010B/7000	1 test per borrow source. ^(a)
	Polychlorinated biphenyls	EPA Methods SW-846 and 8080	1 test per borrow source. ^(a)
	TPH Chemical Testing	EPA Method 8015	1 test per borrow source. ^(a)
	Atterberg Limits	ASTM D-4318	1 test per 1,000 yd ³ of borrow, minimum of 2 tests per source. Additional tests when material characteristics change.
	Particle Size Analysis	ASTM D-422	1 test per 2,500 yd ³ of borrow, minimum of 2 tests per source. Additional tests when material characteristics change.
	USCS Classification	ASTM D-2487	1 test per 2,500 yd ³ of borrow, minimum of 2 tests per source. Additional tests when material characteristics change.
	Moisture Content	ASTM D-2216	1 test per 1,000 yd ³ of borrow, minimum of 2 tests per source. Additional tests when material characteristics change.
Bedding Layer Material	Target Compound List Organics	EPA Methods SW-846, 8270C, and 8260B	1 test per borrow source. ^(a)
	Target Analyte List Inorganics	EPA Methods SW-846 and 6010B/7000	1 test per borrow source. ^(a)
	Polychlorinated biphenyls	EPA Methods SW-846 and 8080	1 test per borrow source. ^(a)
	TPH Chemical Testing	EPA Method 8015	1 test per borrow source. ^(a)
	Compaction Characteristics of Soil	ASTM D-1557	1 test per 1,000 yd ³ of borrow, minimum of 2 tests per source. Additional tests when material characteristics change.
	Density of Soil In-Place by Nuclear Methods	ASTM D-2922	4 tests per acre per lift.
	Rapid Moisture Content	ASTM D-3017	4 tests per acre per lift.

(a) Samples will be composite samples, collected from at least 10 uniformly spaced locations in the borrow pit(s). Samples will be collected from a depth of 1-2 ft below existing grade before borrow operations begin. Contractor will composite soil from 10 locations into one sample, which will then be sent to the accepted testing laboratory for analysis. Analytical results will be reported within 20 days of sample receipt by the laboratory.

NOTE: EPA = U.S. Environmental Protection Agency.
TPH = Total petroleum hydrocarbon.
ASTM = American Society of Testing and Materials.
USCS = Unified Soil Classification System.

Material	Test	Test Method	Frequency
Bedding Layer Material (Continued)	Particle Size Analysis	ASTM D-422	1 test per 2,500 yd ³ of borrow, minimum of 2 tests per source. Additional tests when material characteristics change.
	Atterberg Limits	ASTM D-4318	1 test per 1,000 yd ³ of borrow, minimum of 2 tests per source. Additional tests when material characteristics change.
	USCS Classification	ASTM D-2487	1 test per 2,500 yd ³ of borrow, minimum of 2 tests per source. Additional tests when material characteristics change.
	Moisture Content	ASTM D-2216	1 test per 1,000 yd ³ of borrow, minimum of 2 tests per source. Additional tests when material characteristics change.
Barrier Protection Layer	Target Compound List Organics	EPA Methods SW-846, 8270C, and 8260B	1 test per borrow source. ^(a)
	Target Analyte List Inorganics	EPA Methods SW-846 and 6010B/7000	1 test per borrow source. ^(a)
	Polychlorinated biphenyls	EPA Methods SW-846 and 8080	1 test per borrow source. ^(a)
	TPH Chemical Testing	EPA Method 8015	1 test per borrow source. ^(a)
	Compaction Characteristics of Soil	ASTM D-1557	1 test per 5,000 yd ³ of borrow, minimum of 2 tests per source. Additional tests when material characteristics change.
	Density of Soil In-Place by Nuclear Methods	ASTM D-2922	9 tests per acre per lift.
	Rapid Moisture Content	ASTM D-3017	9 tests per acre per lift.
	Particle Size Analysis	ASTM D-422	1 test per 2,500 yd ³ of borrow, minimum of 2 tests per source. Additional tests when material characteristics change.
	Atterberg Limits	ASTM D-4318	1 test per 1,000 yd ³ of borrow, minimum of 2 tests per source. Additional tests when material characteristics change.
	USCS Classification	ASTM D-2487	1 test per 2,500 yd ³ of borrow, minimum of 2 tests per source. Additional tests when material characteristics change.
	Moisture Content	ASTM D-2216	1 test per 1,000 yd ³ of borrow, minimum of 2 tests per source. Additional tests when material characteristics change.
	Hydraulic Conductivity	ASTM D-5084	1 test per 5,000 yd ³ of borrow, minimum of 2 tests per source. Additional tests when material characteristics change.
	Low-Permeability Clay Liner	Target Compound List Organics	EPA Methods SW-846, 8270C, and 8260B
Target Analyte List Inorganics		EPA Methods SW-846 and 6010B/7000	1 test per borrow source. ^(a)
Polychlorinated biphenyls		EPA Methods SW-846 and 8080	1 test per borrow source. ^(a)
TPH Chemical Testing		EPA Method 8015	1 test per borrow source. ^(a)
Particle Size Analysis		ASTM D-422	1 test per 2,500 yd ³ of borrow, minimum of 2 tests per source. Additional tests when material characteristics change.
Particle Size- No. 200 Sieve		ASTM D-1140	1 test per 2,500 yd ³ of borrow minimum of 2 tests per source. Additional tests when material characteristics change.

Material	Test	Test Method	Frequency
Low-Permeability Clay Liner (Continued)	Atterberg Limits	ASTM D-4318	1 test per 1,000 yd ³ of borrow, minimum of 2 tests per source. Additional tests when material characteristics change.
	Compaction Characteristics of Soil	ASTM D-1557	1 test per 5,000 yd ³ of borrow, minimum of 2 tests per source. Additional tests when material characteristics change.
	Density of Soil In-Place by Nuclear Methods	ASTM D-2922	9 tests per acre per lift.
	Rapid Moisture Content	ASTM D-3017	9 tests per acre per lift.
Topsoil	Target Compound List Organics	EPA Methods SW-846, 8270C, and 8260B	1 test per borrow source. ^(a)
	Target Analyte List Inorganics	EPA Methods SW-846 and 6010B/7000	1 test per borrow source. ^(a)
	Polychlorinated biphenyls	EPA Methods SW-846 and 8080	1 test per borrow source. ^(a)
	TPH Chemical Testing	EPA Method 8015	1 test per borrow source. ^(a)
	Organic Content	AASHTO – T194	1 test per 20,000 yd ³ source of borrow material. Additional tests when material characteristics change.
	Gradation	ASTM D-422 PTM No. 103	1 test per 2,500 yd ³ of borrow material, minimum of 2 tests per source. Additional tests when material characteristics change.

TABLE 2 GEOSYNTHETIC MATERIAL QUALITY ASSURANCE TESTING FOR THE WITMER ROAD LANDFILL
DESIGN-BUILD SITE CLOSURE, NIAGARA FALLS, NEW YORK

Material	Test	Test Method	Requirement	Frequency	Reporting	
Membrane Liner (Smooth and Textured)	Bonded field seam strength	ASTM D-3083	FTB and 40 lb/in. (both smooth and textured), minimum 3 of 4 samples must pass	One test per 500 ft of seaming; a minimum of 1 test for each seaming machine operating on a given day	Within 5 days of performance	
	Field seam peel adhesion (independent laboratory using procedures acceptable to New York State Department of Environmental Conservation)	ASTM D-413	FTB and 30 lb/in. (textured), minimum 3 of 4 samples must pass FTB and 35 lb/in. (smooth), minimum 3 of 4 samples must pass	Same as above	Within 5 days of performance	
	Bonded field seam width.	---	1.75 in., fusion welding	One per 3,000 linear ft of seaming or 1 per seaming period, whichever is more frequent	Within 5 days of performance	
	Air pressure testing (double fusion seam)	See Specification Section 02372	Maximum pressure drop of 4 psi in 5 minutes at 25 psi test pressure	Each wedge-welded seam continuously	Within 5 days of performance, and prior to placing overlying materials	
	Material properties	See Specification Section 02372	See Specification Section 02372	One test for each property per 100,000 ft ² or every second roll, whichever is more frequent, by the manufacturer	Within 10 days before material shipments are delivered to the site	
	Friction coefficient	ASTM D-5321	Same as above	One each between geocomposite/membrane, geocomposite/soil	Within 5 days of performance results, prior to material delivery to site	
	Thickness	ASTM D-5199	40 mil (minimum)	Minimum of 40	Within 5 days of performance	
	Elongation at break	ASTM D-638	400% minimum, smooth 400% minimum, textured	Minimum of 40	Within 5 days of performance	
	Tensile strength at break	ASTM D-638	65 lb/in., smooth 65 lb/in., textured	Minimum of 40	Within 5 days of performance	
	Vacuum test	See Specification Section 02372	5 psig vacuum	All extrusion seams	Within 5 days of performance	
	NOTE: ASTM = American Society of Testing and Materials. FTB = Film Tear Bond.					

Attachment A
Quality Assurance Forms

DAILY CONSTRUCTION REPORT

Report No.								
Date:		Sun	Mon	Tue	Wed	Thur	Fri	Sat
Weather:	Brt Sun	Clear	Overcast	Rain	Snow			
Temperature:	To 32	32-50	50-70	70-85	85 +			
Wind:	Still	Mod	High	Humidity		Dry	Mod	Humid
Contractors:								
Visitors (Time & Representing)								
Equipment on site: (type & number)								
Construction Activities								
Location #1.								
Location #2.								
Location #3.								
Testing Activities:								
Test Equipment Calibrations:								
Materials Received:								
Photographs Taken:	Location #1 - Description				Location #2 - Description			
	Location #3 - Description				Location #4 - Description			
Safety Infractions and Action Taken								
SIGNED					TITLE			

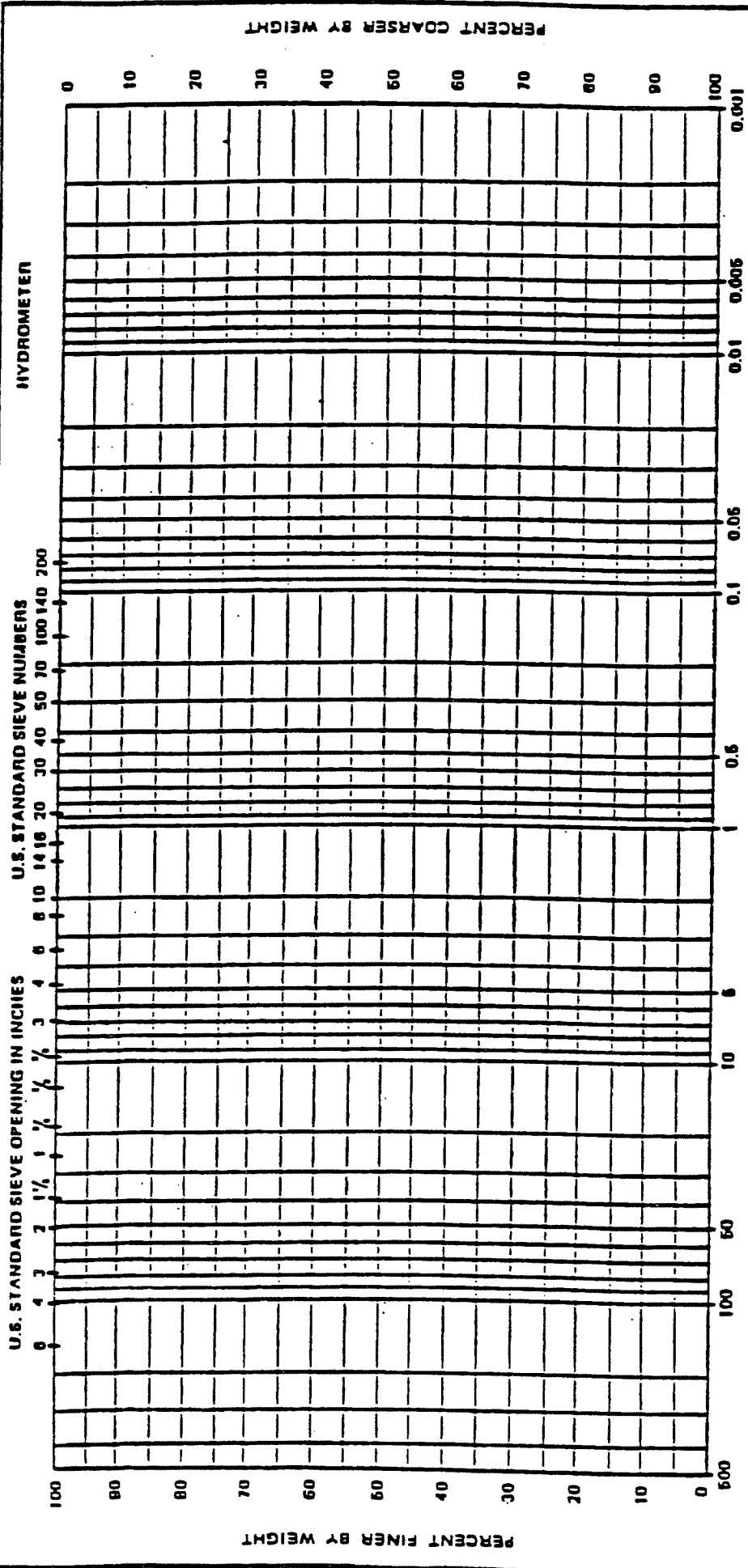

COBBLES	GRAVEL		SAND			SILT OR CLAY	
	COARSE	FINE	COARSE	MEDIUM	FINE		

SAMPLE NO.	ELEV. OR DEPTH	CLASSIFICATION	NATWX	LL	PL	PI	PROJECT
							AREA

INSPECTOR'S DAILY REPORT OF COMPACTED FILL

DATE _____

DAY

S	M	T	W	TH	F	S
---	---	---	---	----	---	---

PROJECT _____
 JOB NO. _____
 CLIENT _____
 CONTRACTOR _____
 PROJECT MANAGER _____

WEATHER	Clear	Overcast	Rain	Snow
TEMP.	70-80	60-70	70-85	65 up
WIND	Wind	High	Report No.	
HUMIDITY	Dry	Moist	Humid	

Grading Contractor	Contractor's Supt. or Foreman	Field Tech.	Mtr. on Site
Source and Description of Fill Materials	Approximate Fill Yards		
	Total Req'd	Placed this shift	Total to Date

Test No.	Test Location	Elevation or Depth	Soil Type	Fill Moisture %	Test Dry Density lbs./cu. ft.	% of Max. Dry Density

Remarks: Describe equipment used for hauling, spreading, watering, conditioning and compacting, also report thickness of lifts, removal of poor soil, soil insufficiently compacted, and comment on unusual events.

DISTRIBUTION. 1. Proj. Mgr.
 2. Field Office
 3. File

BY _____ TITLE _____

MOVING AVERAGE AND TEST RESULT SUMMARY

PROJECT _____	PROJECT NO. _____
CONTRACTOR _____	CONTRACT NO. _____

Material _____

Test _____

SPECIFICATION {

Moving Average _____

Individual _____

Test Results _____

JOB STAMP

GRAPHICAL SUMMARY

Test No.	Date and Time	Samples Taken	Test Result	Sum + by	Moving Avg.	[Empty Grid]			

Remarks _____

NOTICE OF MATERIAL TO BE INSPECTED OR SAMPLED

TO _____

Date _____
 Project Title _____

 Project No. _____
 Contract No. _____
 Purchase Order _____
 Work Order No. _____
 Service Agreement No. _____

Project
 Contractor: _____

Please proceed with inspection of the following materials in accordance with the attached specifications, drawings, and/or referred standards at the suppliers' or manufacturers' plants.

CONTRACT ITEM	MATERIAL	QUANTITY	SUBCONTRACTOR SUPPLIER OR MANUFACTURER

Remarks:

Correspondence and invoices shall include Contract Item Number, Contract Number, Work Order Number, Service Agreement Number and material covered.

Attachments: Specifications
 Drawings

- Distribution:
- 1. Original - Inspection Agency
 - 2. 1 - Project Manager
 - 3. 2 - Resident Project Representative
 - 4. 1 - File

By _____
 Title _____

Appendix C
Design Specifications

**Technical Specifications
Witmer Road Landfill
Niagara Falls, New York**

Prepared for

The BOC Group
100 Mountain Avenue
Murray Hill, New Jersey 07974

Prepared by

EA Engineering, P.C. and Its Affiliate
EA Engineering, Science, and Technology
3 Washington Center
Newburgh, New York 12550
(914) 565-8100

April 2000
Revision: FINAL
Project No. 12040.65

TABLE OF CONTENTS

<u>SECTION</u>	<u>TITLE</u>
01351	Safety, Health, and Emergency Response
01410	Environmental Protection
01500	Temporary Facilities and Controls
01700	Execution Requirements
02230	Clearing and Grubbing
02300	Earthwork
02301	Bedding Layer
02302	Barrier Protection Layer
02372	Geomembrane
02373	Geocomposite
02374	Geotextile
02377	Low-Permeability Clay Liner
02433	Drainage Structures
02831	Chain-Link Fence
02921	Seeding

SECTION 01351

SAFETY, HEALTH, AND EMERGENCY RESPONSE

PART 1 GENERAL

1.1 DESCRIPTION OF WORK

This section specifies a Site Safety and Health Plan (SSHP) which shall apply to work performed in both "contaminated" and "clean" areas.

1.2 REGULATORY REQUIREMENTS

Work performed under this contract shall comply with Occupational Safety and Health Administration (OSHA) standards, 29 CFR 1910, especially Section .120, "Hazardous Waste Site Operations and Emergency Response" and 29 CFR 1926, especially Section .65, "Hazardous Waste Site Operations and Emergency Response".

1.3 SITE SAFETY AND HEALTH PLAN

A Site Safety and Health Plan (SSHP) shall be prepared covering onsite work to be performed by the Contractor and all subcontractors. The Safety and Health Manager shall be responsible for the development, implementation and oversight of the SSHP. The SSHP shall establish, in detail, the protocols necessary for the anticipation, recognition, evaluation, and control of hazards associated with each task performed. The SSHP shall address site-specific safety and health requirements and procedures based upon site-specific conditions. The level of detail provided in the SSHP shall be tailored to the type of work, complexity of operations to be performed, and hazards anticipated. Details about some activities may not be available when the initial SSHP is prepared and submitted. Therefore, the SSHP shall address, in as much detail as possible, anticipated tasks, their related hazards and anticipated control measures.

1.4 SITE DESCRIPTION AND CONTAMINATION CHARACTERIZATION

1.4.1 Project/Site Conditions

Boring logs, test pit logs, and chemical waste analyses are included in "Summary Report, Pre-Design Investigation," EA, 2000.

1.4.2 Plan Requirements

The SSHP shall include a site description and contamination characterization section that addresses the following elements:

- A. Description of site location, topography, size and past uses of the site.
- B. A list of contaminants, which may present occupational health and safety, hazards.

1.5 SITE HAZARDS

The following potential hazards may be encountered during site work. These are not complete lists; therefore, they shall be expanded and/or revised as necessary during preparation of the SSHP.

1.5.1 Safety Hazards

The following hazards may be present: excavations, slips, trips, and faults; electricity; construction equipment and machinery; trenching; debris handling; and underground lines.

1.5.2 Chemical Hazards

The SSHP shall describe the chemical, physical, and toxicological properties of contaminants, sources and pathways of employee exposures, anticipated onsite and offsite exposure level potentials, and regulatory (including Federal, state, and local) or recommended protective exposure standards. The SSHP shall also address employee exposure to hazardous substances brought onsite, and shall comply with the requirements of 29 CFR 1910, Section .1200 and 29 CFR 1926, Section .59, Hazard Communication.

1.5.3 Physical Agents

The following hazards may be encountered: noise, heat and cold stress and vibration.

1.5.4 Biological Hazards

Poisonous plants, animals, and ticks (Lyme Disease) may be encountered.

1.6 ACTION LEVELS

1.6.1 General

Action levels shall be established for site operations. The action levels and required actions (engineering controls, changes in PPE, etc.) shall be presented in the SSHP.

1.7 STAFF ORGANIZATION, QUALIFICATIONS, AND RESPONSIBILITIES

An organizational structure shall be developed that sets forth lines of authority (chain of command), responsibilities, and communication procedures concerning site safety, health, and emergency response. This organizational structure shall cover management, supervisors and employees of the Contractor and subcontractors.

1.7.1 Site Superintendent

A Site Superintendent, who has responsibility to implement the SSHP, the authority to direct work performed under this contract and verify compliance, shall be designated.

1.7.2 Safety and Health Manager

The Safety and Health Manager shall:

- A. Be responsible for the development, implementation, oversight, and enforcement of the SSHP.
- B. Conduct initial site-specific training.
- C. Be present onsite during the first day of remedial activities and at the startup of each new major phase.
- D. Visit the site as needed to audit the effectiveness of the SSHP.
- E. Be available for emergencies.
- F. Provide onsite consultation as needed to ensure the SSHP is fully implemented.
- G. Provide continued support for upgrading/downgrading of the level of personal protection.
- H. Be responsible for evaluating air monitoring data and recommending changes to engineering controls, work practices, and PPE.
- I. Review accident reports and results of daily inspections.

1.7.3 Site Safety and Health Officer (SSHO)

The Site Safety and Health Officer shall:

- A. Assist and represent the Safety and Health Manager in onsite training and the day to day onsite implementation and enforcement of the accepted SSHP.
- B. Be assigned to the site on a full time basis for the duration of field activities. The SSHO shall have no duties other than Safety and Health related duties.
- C. Have authority to stop work if unacceptable health or safety conditions exist, and take necessary action to re-establish and maintain safe working conditions.
- D. Consult with and coordinate any modifications to the SSHP with the Safety and Health Manager and the Site Superintendent.
- E. Conduct accident investigations and prepare accident reports.
- F. Review results of daily quality control inspections and document safety and health findings into the Daily Safety Inspection Log.
- G. In coordination with site management and the Safety and Health Manager, recommend corrective actions for identified deficiencies and oversee the corrective actions.

1.8 TRAINING

Personnel shall receive training in accordance with the Contractor's written safety and health training program and 29 CFR 1910 Section .120, 29 CFR 1926

Section .65, and 29 CFR 1926 Section .21. The SSHP shall include a section describing training requirements.

1.9 PERSONAL PROTECTIVE EQUIPMENT

1.9.1 General

In accordance with 29 CFR 1910 Section .120 (g) (5) and 29 CFR 1926 Section .65 (g) (5), a written Personal Protective Equipment (PPE) program which addresses the elements listed in that regulation, and which complies with respiratory protection program requirements of 29 CFR 1910 Section .134, is to be included in the employer's Safety and Health Program.

1.9.2 Levels of Protection

The Safety and Health Manager shall establish appropriate levels of protection for each work activity based on review of historical site information, existing data, an evaluation of the potential for exposure (inhalation, dermal, ingestion, and injection) during each task, past air monitoring results, and a continuing safety and health monitoring program. The Safety and Health Manager shall also establish action levels for upgrade or downgrade in levels of PPE from the following specified minimum levels of protection.

1.10 MEDICAL SURVEILLANCE

The SSHP shall detail the medical surveillance program that includes scheduling of examinations, certification of fitness for duty, compliance with OSHA requirements, and information provided to the physician.

1.11 SITE CONTROL MEASURES

In order to prevent the spread of contamination and control the flow of personnel, vehicles, and materials into and out of work areas, site control measures shall be established and described in the SSHP.

1.11.1 Site Control Log

A log of personnel visiting, entering, or working on the site shall be maintained. The log shall include the following: date, name, agency or company, and time entering and exiting site.

1.12 EQUIPMENT DECONTAMINATION

Vehicles and equipment used onsite shall be decontaminated prior to leaving the site. The procedures for decontamination of vehicles and equipment shall be addressed in the SSHP.

1.13 EMERGENCY EQUIPMENT AND FIRST AID REQUIREMENTS

The SSHP shall describe the emergency and first aid equipment to be available onsite. The following items, as a minimum, shall be maintained onsite and available for immediate use:

- A. First aid equipment and supplies.
- B. Emergency eyewashes which comply with ANSI Z358.1.

- C. Fire extinguishers with a minimum rating of 20-A:120-B:C shall be provided at site facilities.

1.14 EMERGENCY RESPONSE AND CONTINGENCY PROCEDURES

An Emergency Response Plan, that meets the requirements of 29 CFR 1910 Section .120 (1) and 29 CFR 1926 Section .65 (1), shall be developed and implemented as a section of the SSHP. In the event of any emergency associated with remedial action, the Contractor shall, without delay, alert all onsite employees that there is an emergency situation; take action to remove or otherwise minimize the cause of the emergency; and institute measures necessary to prevent repetition of the conditions or actions leading to, or resulting in, the emergency. The following elements, as a minimum, shall be addressed in the plan:

- A. Pre-emergency planning. The local emergency response agencies shall be contacted during preparation of the Emergency Response Plan.
- B. Personnel roles, lines of authority, communications for emergencies.
- C. Criteria and procedures for site evacuation (emergency alerting procedures, employee alarm system, emergency PPE and equipment, safe distances, places of refuge, evacuation routes, site security and control).
- D. Specific procedures for decontamination and medical treatment of injured personnel.
- E. Route maps to nearest prenotified medical facility.
- F. Emergency alerting and response procedures including posted instructions and a list of names and telephone numbers of emergency contacts.

1.15 CERTIFICATE OF WORKER/VISITOR ACKNOWLEDGEMENT

A copy of a Contractor-generated certificate of worker/visitor acknowledgement shall be completed and submitted for each visitor and for each employee, following the example certificate at the end of this section.

EXAMPLE CERTIFICATE OF WORKER/VISITOR ACKNOWLEDGMENT

PROJECT NAME _____ CONTRACT NO. _____
PROJECT ADDRESS _____
CONTRACTOR'S NAME _____
[EMPLOYEE'S] [VISITOR'S] NAME _____

The contract for the above project requires the following: that you be provided with and complete formal and site-specific training; that you be supplied with proper personal protective equipment including respirators; that you be trained in its use; and that you receive a medical examination to evaluate your physical capacity to perform your assigned work tasks, under the environmental conditions expected, while wearing the required personal protective equipment. These things are to be done at no cost to you. By signing this certification, you are acknowledging that your employer has met these obligations to you.

I HAVE READ, UNDERSTAND AND AGREE TO FOLLOW THE SITE SAFETY AND HEALTH PLAN FOR THIS SITE.

Name

Date

FORMAL TRAINING: I have completed the following formal training courses that meet OSHA's requirements:

Date Completed

40 hour: _____
8 hour supervisory:..... _____
8 hour refresher:..... _____

SITE-SPECIFIC TRAINING: I have been provided and have completed the site-specific training required by this Contract. The Site Safety and Health Officer conducted the training.

RESPIRATORY PROTECTION: I have been trained in accordance with the criteria in [the Contractor's] my Employer's Respiratory Protection program. I have been trained in the proper work procedures and use and limitations of the respirator(s) I will wear. I have been trained in and will abide by the facial hair policy.

RESPIRATOR FIT-TEST TRAINING: I have been trained in the proper selection, fit, use, care, cleaning, and maintenance, and storage of the respirator(s) that I will wear. I have been fit-tested in accordance with the criteria in [the Contractor's] my employer's Respiratory Program and have received a satisfactory fit. I have been assigned my individual respirator. I have been taught how to properly perform positive and negative pressure fit-check upon donning negative pressure respirators each time.

MEDICAL EXAMINATION: I have had a medical examination within the last twelve months which was paid for by my employer. The examination included: health history, pulmonary function tests and may have included an evaluation of a chest ax-ray. A physician made determination regarding my physical capacity to perform work tasks on the project while wearing protective equipment including a respirator. I was personally provided a copy and informed of the results of that examination. My employer's industrial hygienist evaluated the medical certification provided by the physician and checked the appropriate blank below. The physician determined that there:

were no limitations to performing the required work tasks;

were identified physical limitations to performing the required work tasks.

Date medical exam completed

[Employee's] [Visitor's] Signature _____
Date _____

Printed Name _____

Social Security Number _____

Contractor's Site Safety and Health Officer Signature _____

Date _____

Printed Name _____

Social Security Number _____

SECTION 01410

ENVIRONMENTAL PROTECTION

PART 1 GENERAL

1.1 GENERAL REQUIREMENTS

The Contractor shall perform the work minimizing environmental pollution and damage as the result of construction operations. The control of environmental pollution and damage requires consideration of land, water, and air, and includes management of visual aesthetics, noise, solid waste, as well as other pollutants.

1.2 LAND RESOURCES

Except in areas indicated on the Drawings or specified to be cleared, the Contractor shall not remove, cut, deface, injure, or destroy land resources including trees, shrubs, vines, grasses, topsoil, and land forms without permission.

1.3 WATER RESOURCES

The Contractor shall manage construction activities to avoid pollution of surface and ground waters. Temporary erosion and sediment controls may be required in addition to what is shown on the Drawings in accordance with New York Guidelines for Urban Erosion and Sediment Control. Temporary erosion and sediment controls shall be maintained for the duration of the project.

1.4 AIR RESOURCES

Equipment operation and other activities shall be in accordance with the New York State Department of Health Community Air Monitoring Plan NYSDEC TAGM 4031 for Fugitive Dust. Areas affected by the construction activities shall be monitored. A monitoring station will be required for each area of excavating, grading, and filling operations.

1.5 POST CONSTRUCTION CLEANUP

The Contractor shall clean up all areas used for construction.

1.6 RESTORATION OF LANDSCAPE DAMAGE

The Contractor shall restore landscape features damaged or destroyed during construction operations outside the limits of the approved work areas.

PART 2 PRODUCTS

2.1 SILT FENCE

Silt fence shall be Geofab, Envirofence, or approved equal as shown on the Drawings.

2.2 EROSION CONTROL MATTING

Erosion control matting shall be HV Curlex or approved equal as shown on the Drawings.

2.3 STRAW BALE DIKES

Straw bale dike shall be as shown on the Drawings.

PART 3 EXECUTION

3.1 DUST CONTROL

Dust control measures shall be available onsite at all times. Dust control measures shall be implemented in accordance with TAGM 4031. Witmer Road shall be inspected daily and shall be swept clean of dust and dirt that trucks track onto it.

3.2 EQUIPMENT DECONTAMINATION

Equipment shall be decontaminated onsite in accordance with the "Site Safety and Health Plan."

SECTION 01500

TEMPORARY FACILITIES AND CONTROLS

PART 1 GENERAL

1.1 SECTION INCLUDES

- A. Temporary Utilities
 - 1. Temporary electricity.
 - 2. Temporary heating.
 - 3. Temporary cooling.
 - 4. Temporary water service.
 - 5. Temporary sanitary facilities.
- B. Construction Facilities
 - 1. Field offices and sheds.
 - 2. Parking.
- C. Temporary Controls (Fencing)
- D. Removal of Utilities, Facilities, and Controls.

1.2 TEMPORARY ELECTRICITY

- A. A generator shall be provided onsite at the field office to operate a heater, air conditioner, lights, a computer, or other small electrical appliances. The Contractor shall fuel and maintain the generator for the project duration.

1.3 TEMPORARY HEATING

- A. Provide heating devices and heat as needed to maintain specified conditions for construction operations.
- B. Prior to operation of permanent equipment for temporary heating purposes, verify installation is approved for operation, equipment is lubricated and filters are in place. Provide and pay for operation, maintenance, and regular replacement of filters and worn or consumed parts.
- C. Maintain minimum ambient temperature of 60 degrees F in the field office.

1.4 TEMPORARY COOLING

- A. Provide cooling devices and cooling as needed to maintain specified conditions for construction operations.
- B. Prior to operation of permanent equipment for temporary cooling purposes, verify installation is approved for operation, equipment is lubricated and filters are in place. Provide and pay for operation, maintenance, and regular replacement of filters and worn or consumed parts.

- C. Maintain maximum ambient temperature of 70 degrees F in the field office.
- 1.5 TEMPORARY WATER SERVICE
- A. Provide potable drinking water cooler in field office.
- 1.6 TEMPORARY SANITARY FACILITIES
- A. Provide and maintain required facilities and enclosures. Provide facilities at time of project mobilization.
- 1.7 FIELD OFFICES
- A. Office: Weather tight, with lighting, electrical outlets, heating, and cooling equipment, and equipped with sturdy furniture including drawing display table. Provide space for Engineer and NYSDEC personnel.
 - B. Provide space for Project meetings, with table and chairs to accommodate 10 persons.
 - C. Construction: Portable or mobile buildings, or buildings constructed with floors raised above ground, securely fixed to foundations with steps and landings at entrance doors.
 - 1. Construction: Structurally sound, secure, weather tight enclosures for office and storage spaces. Maintain during progress of Work; remove at completion of Work.
 - 2. Fire Extinguishers: Appropriate type fire extinguisher at each office and each storage area.
 - D. Maintenance And Cleaning: Weekly janitorial services for offices; periodic cleaning and maintenance for office and storage areas.
 - E. Removal: At completion of Work remove buildings, foundations, utility services, and debris. Restore areas.
- 1.8 PARKING
- A. Construct temporary gravel surface parking areas to accommodate construction personnel.
 - B. Locate as indicated on Drawings.
- 1.9 FENCING
- A. Maintain existing perimeter fence until new fence is placed. Site access shall be restricted for the duration of the project.
- 1.10 REMOVAL OF UTILITIES, FACILITIES, AND CONTROLS
- A. Remove temporary utilities, equipment, facilities, and materials at completion of project.

PART 2 PRODUCTS

Not Used.

PART 3 EXECUTION

Not Used.

SECTION 01700

EXECUTION REQUIREMENTS

PART 1 GENERAL

1.1 SECTION INCLUDES

- A. Project record documents.

1.2 PROJECT RECORD DOCUMENTS

- A. Maintain on site one set of the following record documents; record actual revisions to the Work:
 - 1. Drawings.
 - 2. Specifications.
 - 3. Addenda.
 - 4. Change Orders and other modifications to the Contract.
 - 5. Reviewed Shop Drawings, Product Data, and Samples.
 - 6. Manufacturer's instruction for assembly, installation, and adjusting.
- B. Ensure entries are complete and accurate, enabling future reference by Owner.
- C. Store record documents separate from documents used for construction.
- D. Record information concurrent with construction progress, not less than weekly.
- E. Specifications: Legibly mark and record at each product section description of actual products installed, including the following:
 - 1. Manufacturer's name and product model and number.
 - 2. Product substitutions or alternates utilized.
 - 3. Changes made by Addenda and modifications.
- F. Record Drawings: Legibly mark each item to record actual construction including:
 - 1. Measured horizontal and vertical locations of underground utilities and appurtenances, referenced to permanent surface improvements.
 - 2. Field changes of dimension and detail.

3. Details not on original Contract drawings.
 4. Perform as-built surveys of subgrade, bedding layer, barrier protection layer, and final conditions.
- G. Submit copies of shop drawings and material submittals to NYSDEC upon approval of each item. Record documents shall be compiled and submitted to NYSDEC as part of the Construction Certification Report upon completion of the project.

PART 2 PRODUCTS

Not Used.

PART 3 EXECUTION

Not Used.

SECTION 02230

CLEARING AND GRUBBING

PART 1 GENERAL

1.1 DEFINITIONS

1.1.1 Clearing

Clearing shall consist of the felling, trimming, and cutting of trees into sections and the satisfactory disposal of the trees and other vegetation designated for removal, including down timber, snags, brush, and rubbish occurring in the areas to be cleared.

1.1.2 Grubbing

Grubbing shall consist of removal and disposal of stumps, roots larger than 3 inches in diameter, and matted roots from the designated grubbing areas.

PART 2 PRODUCTS (NOT APPLICABLE)

PART 3 EXECUTION

3.1 CLEARING

Trees, stumps, roots, brush, and other vegetation in areas to be cleared shall be cut off flush with or below the original ground surface, except such trees and vegetation as may be indicated or directed to be left standing. Clearing shall also include the removal and disposal of structures that obtrude, encroach upon, or otherwise obstruct the work. Topsoil shall be stripped and stockpiled for re-use.

3.2 GRUBBING

Material to be grubbed, shall be removed to a depth of not less than 24 inches below the original surface level of the ground in areas indicated to be grubbed and in areas indicated as construction areas under this contract, such as areas for buildings, and areas to be paved. Depressions made by grubbing shall be filled with suitable material and compacted to make the surface conform with the original adjacent surface of the ground.

3.3 DISPOSAL OF MATERIALS

Logs, stumps, roots, brush, rotten wood, and other refuse from the clearing and grubbing operations, shall be disposed of offsite.

SECTION 02300

EARTHWORK

PART 1 GENERAL

This section covers common borrow fill and general site grading.

PART 2 PRODUCTS

2.1 COMMON BORROW FILL

Common borrow fill shall comprise materials classified by ASTM D 2487 as GW, GP, GM, GP-GM, GC, GP-GC, GM-GC, SW, SP, SM, SW-SM, SC, SW-SC, SP-SM, or SP-SC. Material shall not have stones larger than 8 inches.

Common borrow fill shall not include man-made fills; trash; refuse; backfills from previous construction; nor root or other organic matter or frozen material.

PART 3 EXECUTION

3.1 GENERAL GRADING

General grading shall be in conformity with the typical sections shown to a tolerance of ± 0.2 ft. Grading in drainage swales shall be performed to a tolerance of ± 0.1 ft.

During construction, excavation and fill shall be performed in a manner and sequence that will provide proper drainage at all times.

3.2 COMPACTION

Regraded waste material and common borrow material shall be compacted by tracking over it with construction equipment in maximum 12-in. lifts.

3.3 MATERIAL TESTING

Common borrow fill shall be tested in accordance with the following table:

TEST	METHOD	FREQUENCY
TCLP	EPA SW846	1 test per borrow source.
Particle Size Analysis	ASTM D-422	1 test per 2,500 CY of borrow, minimum of two tests per source. Additional tests when material characteristics change.
Atterberg Limits	ASTM D-4318	1 test per 1,000 CY of borrow, minimum of two tests per source. Additional tests when material characteristics change.

TEST	METHOD	FREQUENCY
USCS Classification	ASTM D-2487	1 test per 2,500 CY of borrow, minimum of two tests per source. Additional tests when material characteristics change.
Moisture Content	ASTM D-2216	1 test per 1,000 CY of borrow, minimum of two tests per source. Additional tests when material characteristics change.

Test results shall be forwarded to NYSDEC.

SECTION 02301

BEDDING LAYER

PART 1 GENERAL

This section covers bedding layer material and placement.

PART 2 PRODUCTS

2.1 BEDDING LAYER MATERIAL

The bedding layer shall comprise materials classified by ASTM D 2487 as GW, GP, GM, GP-GM, GC, GP-GC, GM-GC, SW, SP, SM, SW-SM, SC, SW-SC, SP-SM, or SP-SC. Material shall not have stones larger than 2 inches. The bedding layer shall be certified by a soil scientist or agronomist to be "sufficiently well-drained to prevent frost heave impacts on the geomembrane," as required by NYSDEC.

Bedding layer material shall not include man-made fills; trash; refuse; backfills from previous construction; nor root or other organic matter or frozen material. The surface of the bedding layer, upon which the geomembrane is to be installed, must be reasonably free of stones, organic matter, irregularities, protrusions, loose soil, and any abrupt changes in grade that could damage the geomembrane, as required by 6 NYCRR Part 360-2.13(k)(2)(iv).

PART 3 EXECUTION

3.1 GENERAL GRADING

General grading shall be in conformity with the typical sections shown to a tolerance of ± 0.2 ft.

During construction, excavation and fill shall be performed in a manner and sequence that will provide proper drainage at all times.

3.2 COMPACTION

The bedding layer shall be compacted to 85% maximum Modified Proctor density as determined by ASTM D-1557. Field in-place densities shall be verified by ASTM D-2922. Testing shall be in accordance with the following table:

TEST	METHOD	FREQUENCY
Compaction Characteristics of Soil	ASTM D-1557	1 test per 5,000 CY of borrow, minimum of two tests per source. Additional tests when material characteristics change.
Density of Soil In-Place by Nuclear Methods	ASTM D-2922	4 tests per acre per lift.
Rapid Moisture Content	ASTM D-3017	4 tests per acre per lift.

3.3 MATERIAL TESTING

Bedding layer material shall be tested in accordance with the following table:

TEST	METHOD	FREQUENCY
TCLP	EPA SW846	1 test per borrow source.
Particle Size Analysis	ASTM D-422	1 test per 2,500 CY of borrow, minimum of two samples per source. Additional tests when material characteristics change.
Atterberg Limits	ASTM D-4318	1 test per 1,000 CY of borrow, minimum of two samples per source. Additional tests when material characteristics change.
USCS Classification	ASTM D-2487	1 test per 2,500 CY of borrow, minimum of two samples per source. Additional tests when material characteristics change.
Moisture Content	ASTM D-2216	1 test per 1,000 CY of borrow, minimum of two samples per source. Additional tests when material characteristics change.

Test results shall be forwarded to NYSDEC.

SECTION 02302

BARRIER PROTECTION LAYER

PART 1 GENERAL

This section covers barrier protection layer material and placement.

PART 2 PRODUCTS

2.1 BARRIER PROTECTION LAYER MATERIAL

The barrier protection layer shall comprise materials classified by ASTM D 2487 as GW, GP, GM, GP-GM, GC, GP-GC, GM-GC, SW, SP, SM, SW-SM, SC, SW-SC, SP-SM, or SP-SC. Material shall not have stones larger than 2 inches.

Barrier protection layer material shall have a minimum d_{85} of 0.105 mm and a maximum permeability of 1×10^{-4} cm/sec.

A soil scientist or agronomist shall certify that "the topsoil and barrier protection layer will, acting together, continually support growth of the proposed vegetative cover and not result in root damage to the barrier layer," as required by NYSDEC.

Barrier protection layer material shall not include man-made fills; trash; refuse; backfills from previous construction; nor root or other organic matter or frozen material.

PART 3 EXECUTION

3.1 GENERAL GRADING

General grading shall be in conformity with the typical sections shown to a tolerance of ± 0.2 ft.

During construction, excavation and fill shall be performed in a manner and sequence that will provide proper drainage at all times.

3.2 COMPACTION

The barrier protection layer shall be placed in one lift and compacted to 80% maximum Modified Proctor density as determined by ASTM D-1557. Beneath the perimeter access road, the 18-in. thick barrier protection layer shall be compacted with a smooth-drum roller before the road is constructed on top of it. Field in-place densities shall be verified by ASTM D-2922. ASTM D-2922 testing shall be performed in the top 6 in. of the layer to avoid contact with the geocomposite and geomembrane. Testing shall be in accordance with the following table:

TEST	METHOD	FREQUENCY
Compaction Characteristics of Soil	ASTM D-1557	1 test per 5,000 CY of borrow, minimum of two tests per source. Additional tests when material characteristics change.
Density of Soil In-Place by Nuclear Methods	ASTM D-2922	9 tests per acre per lift.
Rapid Moisture Content	ASTM D-3017	9 tests per acre per lift.

3.3 MATERIAL TESTING

Barrier protection layer material shall be tested in accordance with the following table:

TEST	METHOD	FREQUENCY
TCLP	EPA SW846	1 test per borrow source.
Particle Size Analysis	ASTM D-422	1 test per 2,500 CY of borrow, minimum of two tests per source. Additional tests when material characteristics change.
Atterberg Limits	ASTM D-4318	1 test per 1,000 CY of borrow, minimum of two tests per source. Additional tests when material characteristics change.
USCS Classification	ASTM D-2487	1 test per 2,500 CY of borrow, minimum of two tests per source. Additional tests when material characteristics change.
Moisture Content	ASTM D-2216	1 test per 1,000 CY of borrow, minimum of two tests per source. Additional tests when material characteristics change.
Hydraulic Conductivity	ASTM D-5084	1 test per 5,000 CY of borrow, minimum of two tests per source. Additional tests when material characteristics change.

Test results shall be forwarded to NYSDEC.

SECTION 02372

GEOMEMBRANE

PART 1 GENERAL

1.1 QUALIFICATIONS

1.1.1 Manufacturer

Manufacturer shall have produced the proposed geomembrane sheets for at least 5 completed projects having a total minimum area of 50 million square feet. Manufacturer's qualifications shall be submitted to NYSDEC.

1.1.2 Installer

The installer is responsible for field handling, deploying, seaming, anchoring, and field quality control testing of the geomembrane. The installer shall have installed the proposed geomembrane material for at least 5 completed projects having a total minimum area of 50 acres. At least one seamer shall have experience seaming a minimum of 50 acres of the proposed geomembrane using the same type of seaming equipment and geomembrane thickness specified for this project. Installer's qualifications shall be submitted to NYSDEC.

1.1.3 Independent Laboratory

The independent laboratory is the third party quality assurance laboratory, independent from the manufacturer, fabricator, and installer who is responsible for laboratory quality assurance geomembrane testing. Independent laboratory shall have provided quality control and/or quality assurance testing of the proposed geomembrane seams for at least 5 completed projects having a total minimum area of 50 acres. Laboratory's qualifications shall be submitted to NYSDEC.

1.2 DELIVERY, STORAGE AND HANDLING

The geomembrane shall be protected from puncture, abrasion, excessive heat or cold, material degradation, adhesion of individual layers or other damaging circumstances. Temporary storage at the project site shall be away from standing water and performed without crushing the core of roll goods or flattening of the rolls. A sacrificial opaque and waterproof covering shall be provided over the stored geomembrane for protection against precipitation, ultraviolet exposure, and accidental damage.

1.3 WEATHER LIMITATIONS

Geomembrane shall be deployed and field-seamed only when the geomembrane is dry, winds are low (<20 mph), and there is no precipitation. Geomembrane shall not be deployed outside the range of 32°F - 120°F unless demonstrated that it can be performed in accordance with the seaming requirements.

1.4 EQUIPMENT

Equipment used in performance of the work shall be in accordance with the geomembrane manufacturer's recommendations and shall be maintained in satisfactory working condition.

PART 2 PRODUCTS

2.1 MATERIALS

2.1.1 Raw Materials

Resin used in manufacturing geomembranes shall be made of virgin uncontaminated ingredients. Polyethylene geomembrane resins shall have a density greater than or equal to 0.92 for VFPE. Carbon black used in polyethylene geomembranes shall be a Group 3 category, or lower, as defined in ASTM D 1765 and shall be 2.0 to 3.0 percent by weight in accordance with ASTM D 1603. No more than (2) percent regrind, reworked, or trim material in the form of chips or edge strips shall be used. All regrind, reworked, or trim materials shall be from the same manufacturer and exactly the same formulation as the geomembrane sheet being produced. Materials with previous service life, which are recycled, will not be allowed. Resins shall not contain fatty acid residues, epoxy, or secondary plasticizers.

2.1.2 Sheet Materials

Geomembrane sheets shall be uniform in color, thickness, and surface texture. The sheets shall be free of and resistant to fungal or bacterial attack; and free of cuts, abrasions, holes, blisters, contaminants and other imperfections.

2.1.3 Geomembrane Physical Properties

Geomembrane sheets and factory seams shall conform to the physical requirements listed in Table 1. Test values shown in Table 1, except when specified as minimum or maximum, are minimum average roll values (MARV).

TABLE 1. GEOMEMBRANE PHYSICAL PROPERTIES

PROPERTY	TEST VALUE		TEST METHOD
	<u>Smooth</u>	<u>Textured</u>	
Thickness, mils, (minimum)	40	40	ASTM D 5199
Tensile Strength at Break, lbs/in. width	65	65	ASTM D 638
Elongation at Break, percent	400	400	ASTM D 638
Tear Resistance, lbs	24	24	ASTM D 1004
Puncture Resistance, lbs.	55	68	ASTM D 4833

Water Vapor Transmission Rate, in gram per meter squared per day	<0.03	<0.03	360-2.13 (k)
Low Temperature Brittleness, degrees F	-90	-90	ASTM D 746
Seam Shear Strength, lbs./in. width (minimum) Note 2	48	48	ASTM D 4437
Seam Peel Adhesion, lbs./in. width, (minimum) Note 3	40	40	ASTM D 4437

Note 1: ASTM D 5199 shall be used for non-textured geomembranes and a screw or ported micrometer shall be used for textured geomembranes in accordance with the manufacturer's recommendations.

Note 2: Test results shall be considered passing if the minimum shear strength value is reached or the geomembrane elongates greater than 12 inches without failing regardless of the shear strength value.

Note 3: Seams tested for peel adhesion must fail in the Film Tear Bond mode. This is a failure in the ductile mode of one of the bonded sheets by tearing or breaking prior to complete separation of the bonded area. Where applicable, both tracks of a double hot wedge seam shall be tested for peel adhesion.

2.2 TESTS, INSPECTIONS, AND CERTIFICATIONS

2.2.1 Interface Friction Testing

Laboratory interface friction tests shall be conducted on the interfaces listed below using ASTM D 5321. Normal stresses of 1, 2, and 5 psi along with a displacement rate of 0.04 inches per minute shall be used. Soil components shall be compacted to the same moisture-density requirements specified for full-scale field placement and saturated prior to shear. The shear force in the geosynthetics shall be parallel to the downslope orientation of these components in the field.

A minimum peak interface friction angle is required between materials as described below:

Interface	Minimal Friction Angle
Bedding Layer/Smooth VFPE Membrane	8°
Smooth VFPE Membrane/Geocomposite	8°
Bedding Layer/Textured VFPE Membrane	13°
Textured VFPE Membrane/Geocomposite	13°
Geocomposite/Barrier Protection Layer	13°

One test for each interface shall be performed prior to construction and additional tests shall be performed as material characteristics of borrow sources change.

2.2.2 Manufacturing, Sampling, and Testing

2.2.2.1 Resin Materials

Resin shall be tested in accordance with the approved geomembrane manufacturer's quality control manual. Any resin which fails to meet the geomembrane manufacturer's specified physical properties shall not be accepted for manufacturing the sheet. Polyethylene seaming rod and pellets shall be manufactured of resin which is essentially identical to that used in the geomembrane sheet. Seaming rods and pellets shall be tested for density, melt index, and carbon black content in accordance with the approved geomembrane manufacturer's quality control manual. Seaming rods and pellets which fail to meet the corresponding property values required for the sheet material shall be rejected.

2.2.2.2 Geomembrane Sampling

Geomembrane sheets shall be randomly sampled and tested in accordance with the manufacturer's approved quality control manual. Sheets not meeting the minimum requirements specified in Table 1 shall be rejected.

2.2.2.3 Multi-Axial Tensile Test

As a minimum, one multi axial tensile test shall be run per 200,000 square feet of geomembrane used. Testing shall be conducted prior to installation in accordance with ASTM D 5617.

2.2.3 Fabrication, Sampling, and Testing

2.2.3.1 General

Prior to, or during factory seaming, roll goods shall be visually inspected on both sides for defects and impurities and in accordance with the manufacturer's approved QA plan. Defects and impurities shall be removed and repaired prior to completion of the fabrication process. Thickness measurements shall be made at the center and each edge of the beginning and end of each roll of material in accordance with the methods specified in Table 1. Rolls having a thickness less than the minimum value specified in Table 1 shall be rejected.

2.2.4 Certifications

The geomembrane manufacturer shall certify that the geomembrane meets these specifications. The certification shall specifically include the following items:

- origin and identification of the raw materials used in manufacturing
- quality control certificates from the producer of the raw materials that include test reports that verify specific gravity, melt flow index, percent carbon black, and carbon dispersion

PART 3 EXECUTION

3.1 PREPARATION

3.1.1 Surface Preparation

Rocks larger than 1/2 inch in diameter and any other debris which could damage the geomembrane shall be removed from the surfaces to be covered with the geomembrane. Construction equipment tire or track deformation beneath the geomembrane shall not be greater than 1 inch in depth. The subgrade surface shall be observed daily by the inspector and installer to evaluate the surface condition.

3.1.2 Anchor Trench

Only the amount of anchor trench required for the geomembrane to be anchored in one day shall be excavated. Trench corners shall be slightly rounded to avoid sharp bends in the geomembrane. Loose soil, rock larger than 1 inch in diameter, and any other debris which could damage the geomembrane shall be removed from the surfaces of the trench.

3.2 GEOMEMBRANE DEPLOYMENT

The geomembrane shall be placed with minimum handling. The procedures and equipment used shall not damage the geomembrane or underlying subgrade. Geomembrane damaged during installation shall be removed or repaired as specified in paragraph Patches. Only geomembrane that can be anchored and seamed together the same day shall be deployed. Adequate ballast (e.g., sandbags) shall be placed on the geomembrane, without damaging the geomembrane, to prevent uplift by wind. Only small rubber tired equipment, with maximum tire inflation pressures of 5 LB per square inch, shall be allowed directly on the geomembrane. The method used to deploy the geomembrane shall not scratch, crimp or excessively elongate the geomembrane. Seams shall be oriented parallel to the line of maximum slope. Where seams can only be oriented across the slope, the upper panel/sheet shall be lapped over the lower panel/sheet.

No horizontal seams shall be allowed on slopes greater than 10 horizontal to 1 vertical.

3.2.1 Wrinkles

The method used to deploy the geomembrane shall minimize wrinkles. The geomembrane manufacturer and installer shall coordinate efforts to provide sufficient slack in the deployed geomembrane for the coldest temperature anticipated, to prevent tensile stresses in the geomembrane and its seams during installation and after the geomembrane is covered. The geomembrane shall have adequate slack to prevent uplift from the subgrade or substrate material at any location.

3.2.2 Thickness Measurement

For textured geomembrane, a screw or ported micrometer shall be used to take the same number of thickness readings specified for the non-textured geomembrane. Panels/sheets whose thickness falls below the specified minimum value shall be rejected and replaced.

3.3 FIELD SEAMING

3.3.1 Trial Seams

Trial seams shall be made on test strips of excess geomembrane under field conditions to verify that seaming conditions are adequate. Trial seams shall be made each day prior to production seaming, whenever there is a change in seaming personnel or seaming equipment, and at least once every four hours, by each seamer and each piece of seaming equipment used that day. One sample shall be obtained from each trial seam. This sample shall be at least 36 inches long by 20 inches wide with the seam centered lengthwise. Ten random specimens 1 inch wide shall be cut from the sample. Five seam specimens shall be tested for shear strength and 5 for peel adhesion using an approved quantitative tensiometer. Jaw separation speed shall be in accordance with the installer's approved quality control manual. Where necessary, accelerated curing of trial seams made by chemical fusion methods shall be conducted in accordance with GRI Test Meth GM-7. To be acceptable, 4 out of 5 replicate test specimens shall meet specified seam strength requirements. If the field tests fail to meet these requirements, the entire operation shall be repeated. If the additional trial seam fails, the seaming apparatus or seamer shall not be accepted or used for seaming until the deficiencies are corrected by the installer and 2 consecutive successful trial seams are achieved.

3.3.2 Field Seams

3.3.2.1 General Requirements

Panels/sheets shall be overlapped a minimum of 3 inches. In corners and odd-shaped geometric locations, the number of field seams shall be minimized. Seaming shall extend to the outside edge of panels/sheets to be placed in anchor and/or drainage trenches. Seaming shall not be conducted in the presence of standing water and/or soft subgrades. Wet surfaces shall be thoroughly dried and soft subgrades compacted prior to seaming. The seam area shall be cleaned of dust, dirt, and foreign material prior to and during seaming.

3.3.2.2 Polyethylene Seams

Polyethylene geomembranes shall be seamed by thermal fusion methods. Extrusion welding shall only be used for patching and seaming around appurtenances. If seam overlap grinding is required, the grinding marks shall be oriented perpendicular to the seam direction and no marks shall extend beyond the extrudate after placement. The depth of the grinding marks shall be no greater than 10 percent of the sheet thickness. Extrusion welding shall begin within 10 minutes after grinding. Where extrusion fillet welds are temporarily terminated long enough to cool, they shall be ground prior to applying new extrudate over the existing seam.

3.3.3 Field Sampling and Testing

3.3.3.1 Non-Destructive Field Seam Continuity Testing

Field seams shall be non-destructively tested over their full length in accordance with the procedure below or Installer's approved quality control manual, whichever is stricter, to ensure seam continuity. Seam testing shall be performed as the seaming work progresses, not at the completion of

field seaming. Any seams which fail shall be documented and repaired in accordance with the installer's approved quality control manual.

Vacuum Box Testing: All field seams shall be inspected for unbonded areas by applying a vacuum to a soaped section of seam. The vacuum shall be applied by a vacuum box equipped with a vacuum gage, a clear glass view panel in the top, and a soft rubber gasket on the periphery of the open bottom. The vacuum box shall be similar to the Series A 100 Straight Seam Tester as supplied by the American Parts and Service Company, 2201 West Commonwealth Avenue, P.O. Box 702, Alhambra, California 91802. A section of the seam shall be soaped thoroughly and the inspection box shall be placed over the soaped seam section and the gasket sealed to the cap. A vacuum of between 4 and 8 inches of Mercury (Hg) shall be applied to the box by use of a gasoline or electric driven power-vacuum pump apparatus. The applied vacuum will show bubbles over unbonded areas and the unbonded areas will then be marked for repair.

Pressure Testing: Wedge welded seams shall be pressure tested at 25 psi for 5 minutes. No more than a 3 psi drop is allowed or the seam shall fail and will be cap stripped with a 2-foot wide liner sheet the entire length of the seam.

3.3.3.2 Destructive Field Seam Testing

A minimum of one destructive test sample per seaming machine per 500 feet of field seam shall be obtained. Sample locations shall not be identified prior to seaming. Samples shall be a minimum of 12 inches wide by 42 inches long with the seam centered lengthwise. Each sample shall be cut into two equal pieces with one piece retained by the installer and one piece given to the independent laboratory. Each sample shall be numbered and cross referenced to a field log which identifies: (1) panel/sheet number; (2) seam number; (3) top sheet; (4) date and time cut; (5) ambient temperature within 6 inches above the geomembrane; (6) seaming unit designation; (7) name of seamer; and (8) seaming apparatus temperature and pressures (where applicable). Ten 1-inch wide replicate specimens shall be cut from the installer's sample. Five specimens shall be tested for shear strength and 5 for peel adhesion using an approved field quantitative tensiometer. Jaw separation speed shall be in accordance with the installer's approved quality control manual. To be acceptable, 4 out of 5 replicate test specimens shall meet the specified seam strength requirements. If the field tests pass, 5 specimens shall be tested at the independent laboratory for shear strength and 5 for peel adhesion in accordance with ASTM D 4437. To be acceptable, 4 out of 5 replicate test specimens shall meet specified seam strength requirements. If the field or laboratory tests fail, the seam shall be repaired in accordance with paragraph Destructive Seam Test Repairs. In addition, destructive seam sample holes shall be repaired the same day as cut.

3.3.4 Defects and Repairs

3.3.4.1 Destructive Seam Test Repairs

Seams that fail destructive seam testing may be overlaid with a strip of new material and seamed (cap stripped). Alternatively, the seaming path shall be retraced to an intermediate location a minimum of 10 feet on each side of the failed seam location. At each location a 12 by 18-inch minimum size seam sample shall be taken for two additional shear strength and two

additional peel adhesion tests using an approved quantitative field tensiometer. If these tests pass, then the remaining seam sample portion shall be sent to the independent laboratory for five shear strength and five peel adhesion tests in accordance with ASTM D 4437. To be acceptable, four out of five replicate test specimens must meet specified seam strength requirements. If these laboratory tests pass, then the seam shall be cap stripped between that location and the original failed location. If field or laboratory tests fail, then the process is repeated. After cap stripping, the entire cap stripped seam shall be non-destructively tested.

3.3.4.2 Patches

Tears, holes, blisters and areas with undispersed raw materials or foreign material contamination shall be repaired with patches. Patches shall have rounded corners, be made of the same geomembrane, and extend a minimum of 6 inches beyond the edge of defects. Minor localized flaws shall be repaired by spot welding or seaming. Repairs shall be non-destructively tested.

3.3.4.3 Visual Inspection and Evaluation

Immediately prior to covering the geomembrane, seams and non-seam areas shall be visually inspected for defects, holes, or damage due to weather conditions or construction activities. Each suspect location shall be non-destructively tested. Each location that fails non-destructive testing shall be repaired in accordance with paragraph Patches and non-destructively tested prior to acceptance.

3.4 PENETRATIONS

Tailored area field seams shall be non-destructively tested in accordance with the installer's approved quality control manual. Seams that fail non-destructive testing shall be repaired in accordance with the installer's approved quality control manual and non-destructively tested prior to acceptance.

3.5 PROTECTION AND BACKFILLING

The deployed and seamed geomembrane shall be covered with the required soil within 5 days of deployment. Permanent folding over of geomembrane wrinkles will not be allowed prior to or during placement of cover materials. Placement of soil shall proceed from a stable working area adjacent to the deployed geomembrane and gradually progress outward. Soil shall not be dropped from heights in excess of 3 feet onto the underlying geosynthetics. Equipment with ground pressures less than 5 psi shall be used to place the first lift over the geomembrane.

SECTION 02373

GEOCOMPOSITE

1.1 DESCRIPTION OF WORK

This section specifies the requirements for the cap drainage geocomposite.

1.2 DELIVERY, STORAGE AND HANDLING

The geocomposite materials shall be packaged, shipped, stored, and handled ensuring that no damage is incurred. The Contractor shall be responsible for keeping the geocomposite free of dirt, dust, mud, or any other foreign materials. Each roll shall be labeled with the Manufacturer's name, product identification, lot number, roll number, and roll dimensions. Geocomposite shall be protected from UV exposure during storage and shall not be exposed more than 7 days when placed on the landfill.

PART 2 PRODUCTS

2.1 GEOCOMPOSITE

Geocomposite shall be Tenax Tendrain 70 CN-2 or approved equal. Geocomposite shall be bi-planar or tri-planar with a minimum transmissivity of 1.5×10^{-3} m²/sec. Transmissivity shall be measured using water at 70°F with a gradient of 0.10 under a normal pressure of 200 psf. Geotextiles shall be attached to the geonet in the same configuration as will be used in the field for transmissivity testing. A minimum seating period of 15 minutes shall be used.

2.2 GEOTEXTILE PROPERTIES

The geonet shall be covered on both sides with a geotextile. The geotextile shall be 6 oz/yd² with an AOS of 70.

2.3 BOND PROPERTIES

A geocomposite shall be created by heat bonding geotextiles to the geonet with ply adhesion meeting the requirements of ASTM D 413. The bond between the geotextile and the geonet shall exhibit a minimum peel strength of 1 lbs/inch.

2.4 SAMPLING AND TESTING

2.4.1 General Requirements

A minimum of two transmissivity tests shall be performed in accordance with the requirements specified in Section 2.1.

PART 3 EXECUTION

3.1 INSTALLATION

3.1.1 Surface Preparation

Prior to placement of the geocomposite, the surface of the geomembrane and cap subgrade shall be cleaned of all soil, rock, and other materials which could damage the geocomposite.

3.1.2 Placement

The geocomposite shall be unrolled downslope keeping the net in slight tension to minimize wrinkles and folds. The geocomposite shall be maintained free of dirt, mud, or any other foreign materials at all times during construction. Adequate loading (e.g. sandbags) shall be placed to prevent uplift by wind.

3.1.2.1 Overlap and Fasteners

Adjacent rolls shall be overlapped a minimum of 6 inches. Fasteners, as recommended by the Manufacturer shall be used to join adjacent rolls. Metallic fasteners will not be allowed. Fasteners shall be spaced a maximum of 5 feet along downslope roll overlaps and a maximum of 2 feet along cross slope roll overlaps. Fasteners shall be of contrasting color from the geonet to facilitate visual inspection.

3.2 REPAIRS

Holes or tears in the geocomposite shall be repaired by placing a patch of geonet extending a minimum of 2 feet beyond the edges of the hole or tear. Fasteners, spaced every 6 inches around the patch, shall be used to fasten the patch to the original roll.

3.3 FINAL COVER

Upon completion of the geocomposite in an area, the geocomposite shall be covered with the required materials within 14 days in accordance with the drawings and specifications.

SECTION 02374

GEOTEXTILE

PART 1 GENERAL

1.1 DELIVERY, STORAGE AND HANDLING

Delivery, storage, and handling of geotextile shall be in accordance with ASTM D 4873.

1.1.1 Delivery

Rolls shall be packaged in an opaque, waterproof, protective plastic wrapping. The plastic wrapping shall not be removed until deployment. If quality assurance samples are collected, rolls shall be immediately rewrapped with the plastic wrapping. Geotextile or plastic wrapping damaged during storage or handling shall be repaired or replaced, as directed. Each roll shall be labeled with the manufacturer's name, geotextile type, roll number, roll dimensions (length, width, gross weight), and date manufactured.

1.1.2 Storage

Geotextile rolls shall be protected from becoming saturated. Rolls shall either be elevated off the ground or placed on a sacrificial sheet of plastic. The geotextile rolls shall also be protected from the following: construction equipment, ultraviolet radiation, chemicals, sparks and flames, temperatures in excess of 160 degrees F, and any other environmental condition that may damage the physical properties of the geotextile.

1.1.3 Handling

Geotextile rolls shall be handled and unloaded with load carrying straps, a fork lift with a stinger bar, or an axial bar assembly. Rolls shall not be dragged along the ground, lifted by one end, or dropped to the ground.

PART 2 PRODUCTS

2.1 MATERIALS

2.1.1 Geotextile

Geotextile shall be a nonwoven 10 oz. pervious sheet of polymeric material and shall consist of long-chain synthetic polymers composed of at least 95 percent by weight polyolefins, polyesters, or polyamides. Stabilizers and/or inhibitors shall be added to the base polymer, as needed, to make the filaments resistant to deterioration by ultraviolet light, oxidation, and heat exposure. Regrind material, which consists of edge trimmings and other scraps that have never reached the consumer, may be used to produce the geotextile. Post-consumer recycled material shall not be used. Geotextile shall be formed into a network such that the filaments or yarns retain dimensional stability relative to each other, including the selvages. Geotextiles and factory seams shall meet the requirements specified in Table 1. Where applicable, Table 1 property values represent minimum average roll

values (MARV) in the weakest principal direction. Values for AOS represent maximum average roll values.

TABLE 1. GEOTEXTILE PHYSICAL PROPERTIES

<u>PROPERTY</u>	<u>TEST VALUE</u>	<u>TEST METHOD</u>
Elongation at Break, percent	50	ASTM D 4632
Apparent Opening Size (U.S. Sieve)	100	ASTM D 4751
Permittivity, sec-1	1.0	ASTM D 4491
Puncture, lbs.	150	ASTM D 4633
Grab Tensile, lbs	200	ASTM D 4632
Trapezoidal Tear, lbs.	100	ASTM D 4533
Burst Strength, psi	450	ASTM D 3786
Ultraviolet Stability (percent strength retained at 500 hours)	70	ASTM D 4355
Seam Strength, lbs.	100	ASTM D 4632

2.1.2 Thread

Sewn seams shall be constructed with high-strength polyester, nylon, or other approved thread type. Thread shall have ultraviolet light stability equivalent to the geotextile and the color shall contrast with the geotextile.

2.2 MANUFACTURING QUALITY CONTROL SAMPLING AND TESTING

Manufacturing quality control sampling and testing shall be performed in accordance with the manufacturer's approved quality control manual. As a minimum, geotextiles shall be randomly sampled for testing in accordance with ASTM D 4354, Procedure A.

PART 3 EXECUTION

3.1 QUALITY ASSURANCE SAMPLES AND TESTS

3.1.1 Quality Assurance Samples

Samples shall be collected upon delivery to the site for quality assurance testing at a frequency of one per 100,000 square feet. Samples shall be identified with a waterproof marker by manufacturer's name, product

identification, lot number, roll number, and machine direction. The date and a unique sample number shall also be noted on the sample. The outer layer of the geotextile roll shall be discarded prior to sampling a roll. Samples shall then be collected by cutting the full-width of the geotextile sheet a minimum of 3 feet long in the machine direction. Rolls which are sampled shall be immediately rewrapped in their protective covering.

3.1.2 Quality Assurance Tests

Samples will be tested to verify that geotextile meets the requirements specified in Table 1. Test method ASTM D 4355 shall not be performed on the collected samples. Geotextile product acceptance shall be based on ASTM D 4759. Tests not meeting the specified requirements shall result in the rejection of applicable rolls.

3.2 INSTALLATION

3.2.1 Subgrade Preparation

The surface underlying the geotextile shall be smooth and free of ruts or protrusions which could damage the geotextile. Subgrade materials and compaction requirements shall be in accordance with Section 02300 EARTHWORK.

3.2.2 Placement

Geotextile rolls which are damaged or contain imperfections shall be repaired or replaced as directed. The geotextile shall be laid flat and smooth so that it is in direct contact with the subgrade. The geotextile shall also be free of tensile stresses, folds, and wrinkles. On slopes greater than 5 horizontal on 1 vertical, the geotextile shall be laid with the machine direction of the fabric parallel to the slope direction.

3.3 SEAMS

3.3.1 Overlap Seams

Geotextile panels shall be continuously overlapped a minimum of 12 inches. Where it is required that seams be oriented across the slope, the upper panel shall be lapped over the lower panel. The Contractor has the option of field sewing instead of overlapping.

3.3.2 Sewn Seams

A flat seam with one row of a two-thread chain stitch shall be used unless otherwise recommended by manufacturer. The thread at the end of each seam run shall be tied off to prevent unraveling. Seams shall be on the top side of the geotextile to allow inspection. Skipped stitches or discontinuities shall be sewn with an extra line of stitching with a minimum of 18 inches of overlap.

3.4 PROTECTION

The geotextile shall be protected during installation from clogging, tears, and other damage. Damaged geotextile shall be repaired or replaced as directed. Adequate ballast (e.g. sand bags) shall be used to prevent uplift by wind. The geotextile shall not be left uncovered for more than 14 days during installation.

3.5 REPAIRS

Geotextile damaged during installation shall be repaired by placing a patch of the same type of geotextile which extends a minimum of 12 inches beyond the edge of the damage or defect. Patches shall be continuously fastened using a sewn seam or other approved method. The machine direction of the patch shall be aligned with the machine direction of the geotextile being repaired. Geotextile which cannot be repaired shall be replaced.

3.6 PENETRATIONS

Engineered penetrations of the geotextile shall be constructed by methods recommended by the geotextile manufacturer.

3.7 COVERING

Cover soil shall be placed in a manner that prevents soil from entering the geotextile overlap zone, prevents tensile stress from being mobilized in the geotextile, and prevents wrinkles from folding over onto themselves. No equipment shall be operated directly on top of the geotextile. A minimum of 12 inches of soil shall be maintained between full-scale construction equipment tires/tracks and the geotextile during the covering process.

SECTION 02377

LOW-PERMEABILITY CLAY

PART 1 GENERAL

1.1 DESCRIPTION OF WORK

This section describes the work associated with furnishing and installing low-permeability clay.

PART 2 PRODUCTS

2.1 LOW PERMEABILITY CLAY

Clay shall be free of roots, debris, organic or frozen material, and shall have a maximum clod size of 2 inches at the time of compaction. Clay used must also satisfy the criteria listed in Table 1.

TABLE 1
REQUIRED PHYSICAL PROPERTIES OF CLAY

Property	Test Value	Test Method
Max. particle size (inches)	1	ASTM D 422
Min. percent passing No. 4 sieve	80	ASTM D 422
Min. percent passing No. 200 sieve	50	ASTM D 1140
Min. liquid limit	35	ASTM D 4318
Min. plasticity index	10	ASTM D 4318
Max. plasticity index	40	ASTM D 4318

PART 3 EXECUTION

3.1 BORROW SOURCE ASSESSMENT

3.1.1 General Requirements

Borrow source assessment tests shall be performed on each material proposed for use as low permeability clay to assure compliance with specified requirements and to develop compaction requirements for placement. At a minimum, one set of borrow assessment tests shall be performed for each borrow source proposed. A set of borrow source assessment tests shall consist of classification testing, moisture-density (compaction) testing, and hydraulic conductivity testing.

3.1.2 Classification Testing

Test pits shall be used to characterize each proposed borrow source. Visual classification as described in ASTM D 2488 shall be performed over the full depth of each test pit by a qualified geologist or geotechnical engineer. Soils shall be grouped into "principal types" based on visual classification. Classification testing shall be performed on representative samples of each material. At a minimum, one set of classification tests shall be performed per 2,500 cubic yards of proposed borrow. Classification testing shall consist of liquid and plastic limits in accordance with

ASTM D 4318 for every 1,000 cy and particle size analysis in accordance with ASTM D 422 for every 2,500 cy. Moisture content testing of proposed borrow shall be performed at a frequency of once per 1,000 cubic yards.

3.1.3 Compaction Testing

A representative sample from each principal type or combination of materials shall be tested to establish a compaction curve using ASTM D 1557. A minimum of one set of compaction tests shall be performed per 5,000 cubic yards of proposed borrow. A minimum of 5 points shall be used to develop each compaction curve. The compaction curves shall be plotted on a single graph of dry density versus moisture content.

3.1.4 Hydraulic Conductivity Testing

A set of hydraulic conductivity tests shall be performed on representative samples of each material. A minimum of one set of tests shall be performed per 5,000 cubic yards of proposed borrow. A set of tests shall consist of a minimum of 6 test specimens. The moisture contents and densities of the specimens shall meet the criteria outlined in paragraph Acceptable Zone Development. Hydraulic conductivity testing referenced in this section shall be conducted in accordance with ASTM D 5084. In addition, the following procedures shall also be adhered to when performing the testing:

- a. Saturation of test specimens shall be verified by determination of the B coefficient. The B coefficient must be at least 0.95. The B coefficient is defined as the change in pore water pressure divided by the change in confining pressure.
- b. During consolidation of the test specimens, outflow volumes shall be recorded to confirm primary consolidation has been completed prior to initiation of the hydraulic conductivity test.
- c. The permeant used for back pressure saturation and hydraulic conductivity testing shall be 0.005 N calcium sulfate as specified in ASTM D 5084.
- d. The average effective confining pressure shall be 40 psi.

3.1.5 Acceptable Zone Development

An "Acceptable Zone" of moisture contents and densities shall be developed and displayed on the compaction curve graphs for each material. The "Acceptable Zone" shall consist of moisture-density values that meet the following requirements:

- a. Maximum Allowable Permeability = 1×10^{-7} cm per second
- b. The minimum allowable moisture content shall be no less than optimum moisture content -0.0% based on ASTM D 1557. The maximum allowable moisture content shall be +4.0%.
- c. The minimum allowable density shall be no less than 90% of maximum dry density based on ASTM D 1557.

3.1.6 Chemical Contamination Testing

Borrow used for the clay layer shall be free of contamination. Each proposed borrow source shall be sampled and analyzed for chemical contamination by EPA SW846.

3.1.7 Commercial Testing Laboratory

Tests for the clay layer shall be performed by an approved commercial testing laboratory.

3.2 SUBGRADE PREPARATION

Low permeability clay shall not be placed on surfaces that are muddy, frozen, or contain frost. The subgrade shall be free of contamination, trash, debris, roots or other organic matter, or stones larger than 3 inches in any dimension.

3.2.1 Scarification and Compaction

The excavated or natural ground portion of the subgrade shall be scarified to a depth of 6 inches and compacted to 90% maximum laboratory density (ASTM D 1557).

3.3 INSTALLATION

3.3.1 Clay Placement

Clay shall be placed to the lines and grades shown on the drawings. The clay shall be placed in loose lifts not to exceed 8 inches in thickness. In areas where hand operated tampers must be used, the loose lift thickness shall not exceed 4 inches. If grade stakes are driven into the clay layer to control lift thickness, they shall be numbered and accounted for at the end of each shift. When removing grade stakes, no broken portion of the grade stakes shall be left in the clay layer. Holes left by grade stakes shall be backfilled with clay.

3.3.2 Moisture Control

Clay shall be placed and compacted within the moisture content range -0.0%, +4.0% of optimum. The moisture content shall be maintained uniform throughout each lift. Moisture added shall be thoroughly incorporated into the clay to ensure uniformity of moisture content prior to compaction.

3.3.3 Compaction

Clay shall be compacted to 90% maximum laboratory density (ASTM D 1557).

3.3.4 Scarification

Scarification shall be performed on all areas of the upper surface of each clay lift prior to placement of the next lift. The final lift of clay shall not be scarified.

3.4 CONSTRUCTION TOLERANCES

The top surface of the clay layer shall be no greater than 0.2 feet above the lines and grades shown on the drawings. No minus tolerance will be permitted.

3.5 TESTS

3.5.1 Frequency Tests

Representative samples shall be taken for testing at the frequencies listed in Table 2 after a loose lift of clay has been placed. Test results shall meet the requirements listed in Table 1. Where test results indicate a previously undefined material type, additional testing shall be performed as described in paragraph BORROW SOURCE ASSESSMENT.

TABLE 2
BORROW TESTS

<u>Property</u>	<u>Frequency</u>	<u>Test Method</u>
Percent passing No. 4 sieve	2,500 cubic yards	ASTM D 422
Percent passing No. 200 sieve	2,500 cubic yards	ASTM D 1140
Liquid and plastic limits	1,000 cubic yards	ASTM D 4318
Compaction	5,000 cubic yards	ASTM D 1557

3.5.2 Moisture Content and Density Tests

Moisture content and density tests shall be performed in a grid pattern. The grid pattern shall be staggered for successive lifts so that sampling points are not at the same location in each lift. Moisture content and density tests shall be performed in accordance with Table 3.

TABLE 3
MOISTURE CONTENT AND DENSITY TESTS

<u>Property</u>	<u>Frequency</u>	<u>Test Method</u>
Rapid Moisture Content	9 per acre per lift	ASTM D 3017
Rapid Density	9 per acre per lift	ASTM D 2922

Rapid moisture and density test results shall be checked against standard test results to verify good correlation. A minimum of one moisture content and density test shall be performed each day clay is compacted. Nuclear density gauges shall be used in the direct transmission mode. Nuclear density and moisture calibration curves shall be checked and adjusted by the procedures described in ASTM D 2922 and ASTM D 3017. The nuclear gauge calibration checks shall be made at the beginning of a job, on each

different type of material to be placed, and at intervals as directed. At the start of construction, a minimum of ten measurements shall be made on representative samples of compacted clay using both standard methods and any rapid moisture or density testing methods to be used. Results shall be compared to verify good correlation. The field moisture content and density test results shall be plotted on the "Acceptable Zone" plot that corresponds to the appropriate material type being tested. If test results are not within the "Acceptable Zone" for moisture content or density, 3 additional tests shall be taken at the location of the failed parameter. If all retests pass, no additional action shall be taken. If any of the retests fail, the lift of soil shall be removed and replaced to the limits defined by passing tests for that parameter.

3.5.3 Hydraulic Conductivity Tests

Undisturbed samples shall be taken for hydraulic conductivity testing at a frequency of one per acre per lift of clay placed. Vertical samples shall be cut from the lift in accordance with ASTM D 1587 and transported in the vertical position in accordance with ASTM D 4220, Group C. Each undisturbed sample shall be tested for hydraulic conductivity in accordance with ASTM D 5084, moisture content in accordance with ASTM D 2216, particle size analysis in accordance with ASTM D 422, and liquid and plastic limits in accordance with ASTM D 4318. Hydraulic conductivity testing shall be conducted in accordance with the requirements in paragraph Hydraulic Conductivity Testing. If any test result is greater than the "Maximum Allowable Permeability", modifications shall be proposed and approved for the placement of additional clay of that type. If the hydraulic conductivity of any test is more than the "Maximum Allowable Permeability", the area of the failed test shall be retested and repaired as directed. Holes left by samples shall be backfilled with clay.

3.6 PROTECTION

3.6.1 Weather Conditions

Clay placement and compaction shall not take place during adverse weather conditions of freezing, desiccation, or excessive moisture.

3.6.2 Excess Surface Water

Excess moisture shall be removed prior to placement of additional clay. If in-place clay is reworked and recompacted, affected areas shall be retested at the same frequency as the rest of the project. Erosion that occurs in the clay layer shall be repaired and grades re-established before covering it.

3.6.3 Freezing and Desiccation

Freezing and desiccation of the clay layer shall be prevented. If freezing or desiccation occurs, the affected soil shall be removed or reconditioned. Affected areas shall be retested at the same frequency as the rest of the project.

SECTION 02433

DRAINAGE STRUCTURES

PART 1 GENERAL

1.1 DESCRIPTION

Contractor shall furnish all labor, materials, equipment, and incidentals necessary to install drainage structures including culvert pipes and similar structures as shown, specified, and otherwise required to complete the Work.

PART 2 PRODUCTS

2.1 STONE

Stone used for drainage shall meet the requirements of New York State Department of Transportation Standard Specifications, Construction and Materials, Section 703-02, Coarse Aggregate.

2.2 CORRUGATED METAL PIPE

Pipe denoted as "CMP" shall be bituminous-coated corrugated steel pipe in accordance with New York State Department of Transportation, Standard Specifications, Construction and Materials, Section 707-Metal Pipe.

2.3 HIGH-DENSITY POLYETHYLENE (HDPE) PIPE

Pipe shall be ASTM D-1248, Type 111, Class C, SDR17, classified as Cell 345434C, material PE 3408, and shall meet API-15 LE. Acceptable pipe includes Plexco EHMW PE 3408; Phillips Driscopipe 6400 PE 3408; or approved equal.

The HDPE pipe shall have the following typical physical properties:

<u>Physical Property</u>	<u>Test Method</u>	<u>Nominal Value</u>
Density	ASTM D-1505	0.955 g/cm ³
Tensile Yield Strength	ASTM D-638	3,200 psi
Tensile Modulus of Elasticity	ASTM D-638	130,000 psi
Flexural Modulus	ASTM D-790	135,000 psi
Environmental Stress Condition A,B,C	ASTM D-1693	>5,000 hrs
Compression	ASTM D-1248	>3,500 hrs

The pipe shall be homogeneous throughout and free from visible cracks, holes, foreign inclusions, or other defects. The pipe shall be uniform in color, opacity, density, and other physical properties.

PART 3 EXECUTION

3.1 GENERAL

Install all pipe accurately to line and grade shown within 0.1 feet of vertical elevation shown on plan. Slope piping uniformly between elevations shown. Contractor shall provide As-Builts of pipe installation at a scale equal to that shown on the Contract Drawings. Survey shall be performed by an approved surveyor. At a minimum, elevations of top of installed pipe shall be shot for as-builts every 25 feet.

3.2 CORRUGATED METAL PIPE

3.2.1 General

Pipe, fittings, couplings and accessories shall be handled in a manner that will ensure installation in sound, undamaged condition. Equipment, tools, and methods used in unloading, reloading, hauling, and laying shall be such that the pipe, fittings, couplings and accessories are not damaged. The CONTRACTOR shall repair any damaged pipe coating before installing the pipe.

3.2.2 Bedding

Each run of pipe shall be laid to grade. Sections of the pipe shall be joined using appropriate methods. Each connection shall be made to ensure a tight joint and to form a continuous conduit. The pipe shall be firmly and uniformly bedded throughout its entire length. Where rock or soft, spongy, or other unstable soil is encountered, all such material shall be removed and replaced with suitable earth compacted to provide adequate support.

Where culvert pipe is to be laid on existing ground and on or under fill the Contractor shall construct the embankment to a height of at least 9 inches but not more than 3 feet above top of pipe and then excavate a trench to receive the pipe. Trench shall be no wider than necessary to permit proper tamping of embedment around the pipe.

3.2.3 Laying Pipe

All CMP shall be placed with inside circumferential laps pointing downstream and with the longitudinal laps at the sides. The interior of all pipe, fittings, and couplings shall be thoroughly cleaned of all foreign matter before being installed. Before jointing, all joint contact surfaces shall be wire brushed if necessary, wiped clean, and kept clean until jointing is completed.

3.3 HDPE Pipe

3.3.1 General

Install piping as shown, specified, and recommended by the manufacturer. Minimum cover over piping shall be as shown on the drawings. Pipe, fittings, specials, and accessories that are cracked, damaged or in poor condition or have damaged linings will be rejected.

3.3.2 Bedding

Bed pipe as specified below and in accordance with the details shown. Excavate trenches below the pipe bottom by an amount shown and specified. Remove all loose and unsuitable material from the trench bottom. Carefully and thoroughly compact pipe bedding with hand held pneumatic compactors. No welded pipe run shall be brought into position until the preceding length has been bedded and secured in its final position.

3.3.3 Laying Pipe

Conform to manufacturer's instructions and requirements of ASTM D2774 and D2321. Snake piping in trench to compensate for thermal expansion as recommended by manufacturer. Ensure that water level in trench is at least 6 inches below bottom of pipe before laying piping. Do not lay pipe in water. Maintain dry trench conditions until jointing and backfilling are complete. Inspect interior of all pipe and fittings and completely clean

all dirt, gravel, sand, debris, or other foreign material from pipe interior before it is moved into the trench.

Field cut pipe, where required, with a machine specially designed for cutting piping. Make cuts carefully, without damage to pipe or lining, and with a smooth end at right angles to the axis of pipe. Cut ends on push-on joint shall be tapered and sharp edges filed off smooth. Flame cutting will not be allowed.

3.3.4 HDPE Butt Fusion Joints

Pipe joints shall be butt fused and comply with the manufacturer's instructions concerning equipment, temperature, melt time, heat coat, and joining time. During fusion procedures, check the heater plate temperature routinely to ensure the proper temperature is maintained.

3.3.5 Backfill

Place backfill as construction progresses. Backfill by hand and use power tampers until pipe is covered by at least 1 foot of fill.

SECTION 02831

CHAIN-LINK FENCE

PART 1 GENERAL

1.1 DESCRIPTION

This Section includes the requirements for providing all labor, materials, equipment, and incidentals necessary for construction of a chain link fence and gate system, as specified herein and shown on the Contract Drawings.

PART 2 PRODUCTS

2.1 MATERIALS

Materials shall conform to the following.

2.1.1 Chain Link Fence

FS RR-F-191/GEN.

2.1.1.1 Fabric

FS RR-F-191/1, Type I, zinc-coated steel wire with minimum coating weight of 1.2 ounces of zinc per square foot of coated surface, or Type II, aluminum-coated steel wire. Fabric shall be fabricated of 9-gauge wire woven in 2-inch mesh. Fabric height shall be as shown. Fabric shall be twisted and barbed on the top selvage and knuckled on the bottom selvage.

2.1.1.2 Gates

FS RR-F-191/2. Gate shall be the type and swing shown. Gate frames shall be constructed of Class 1 Grade A or B, steel pipe, size SP2, as specified in FS RR-F-191/3. Gate fabric shall be as specified for chain-link fabric. Gate leaves more than 8 feet wide shall have either intermediate members and diagonal truss rods or shall have tubular members as necessary to provide rigid construction, free from sag or twist. Gate leaves less than 8 feet wide shall have truss rods or intermediate braces. Intermediate braces shall be provided on all gate frames with an electro-mechanical lock. Gate fabric shall be attached to the gate frame by method standard with the manufacturer except that welding will not be permitted. Latches, hinges, stops, keepers, rollers, and other hardware items shall be furnished as required for the operation of the gate. Latches shall be arranged for padlocking so that the padlock will be accessible from both sides of the gate. Stops shall be provided for holding the gates in the open position.

2.1.1.3 Posts

FS RR-F-191/3, zinc-coated; Class 1 Grade A or B, steel pipe; Class 3, formed steel sections; or Class 6, steel square sections. Class 4, steel H-section may be used for line posts in lieu of line post shapes specified for the other classes. Sizes shall be as shown on the drawings. Line posts and terminal (corner, gate, and pull) posts selected shall be of the same class throughout the fence. Gate post shall be either round or square, subject to the limitation specified in FS RR-F-191/3.

2.1.1.4 Braces and Rails

FS RR-F-191/3, zinc-coated, Class 1, Grade A or B, steel pipe, size SP1. Class 3, formed steel sections, size FS1, conforming to FS RR-F-191/3, may be used as braces and rails if Class 3 line posts are furnished.

2.1.1.5 Accessories

FS RR-F-191/4. Ferrous accessories shall be zinc or aluminum coated. Truss rods shall be furnished for each terminal post. Truss rods shall be provided with turnbuckles or other equivalent provisions for adjustment. Tie wire for attaching fabric to rails, braces, and posts shall be 9-gauge steel wire.

2.1.2 Concrete

ASTM C 94, using 3/4-inch maximum size aggregate, and having minimum compressive strength of 3,000 psi at 28 days. Grout shall consist of one (1) part portland cement to three (3) parts clean, well-graded sand and the minimum amount of water to produce a workable mix.

2.1.3 Padlocks

ASTM F 883, Type PO1, Grade 2, Size 1-3/4 inch. Padlocks shall be keyed alike and each lock shall be furnished with two (2) keys.

PART 3 EXECUTION

3.1 GENERAL

Fence shall be installed to the lines and grades indicated. Terminal (corner, gate, and pull) posts shall be set at abrupt changes in vertical and horizontal alignment. Fabric shall be continuous between terminal posts; however, runs between terminal posts shall not exceed 500 feet. Damage to the galvanized surface due to welding shall be repaired with "repair sticks" of zinc-cadmium alloys or zinc-tin-lead alloys per AWS WZC.

3.2 EXCAVATION

The ground surface irregularities along the fence line shall be eliminated to the extent necessary to maintain a 2-inch clearance between the bottom of the fabric and finish grade.

3.3 POSTS

Posts shall be set plumb and in alignment. Corner, end, and gate posts set in concrete shall be set in holes not less than the diameter shown on the drawings. Diameters of holes in solid rock shall be at least 1 inch greater than the largest cross section of the post. Concrete and grout shall be thoroughly consolidated around each post, shall be free of voids and finished to form a dome. Concrete and grout shall be allowed to cure for 72 hours prior to attachment of any item to the posts.

3.4 BRACES AND TRUSS RODS

Braces and truss rods shall be installed as indicated and in conformance with the standard practice for the fence furnished. Horizontal (compression) braces and diagonal truss (tension) rods shall be installed on the fence. Braces and truss rods shall extend from terminal posts to line posts. Diagonal braces shall form an angle of approximately 40 to 50 degrees with the horizontal.

3.5 TENSION WIRES

Tension wires shall be installed along the top and bottom of the fence line and attached to the terminal posts of each stretch of the fence. Top tension wires shall be installed within the top 4 inches of the installed fabric. Bottom tension wire shall be installed within the bottom 6 inches of the installed fabric. Tension wire shall be pulled taut and shall be free of sag.

3.6 CHAIN LINK FABRIC

Chain link fabric shall be installed on the side of the post indicated. Fabric shall be attached to terminal posts with stretcher bars and tension bands. Bands shall be spaced at approximately 15-inch intervals. The fabric shall be installed and pulled taut to provide a smooth and uniform appearance free from sag, without permanently distorting the fabric diamond or reducing the fabric height. Fabric shall be fastened to line posts at approximately 15-inch intervals and fastened to all rails and tension wires at approximately 24-inch intervals. Fabric shall be cut by untwisting and removing pickets. Splicing shall be accomplished by weaving a single picket into the ends of the rolls to be joined. The bottom of the installed fabric shall be 1 inch (plus or minus 1/2 inch) above the ground.

3.7 GROUNDING

Fence shall be grounded at each side of every gate, where the fence alignment changes more than 15 degrees, and at maximum intervals of 650 feet of length. Fences crossed by powerlines of 600 volts or more shall be grounded at or near the point of crossing and at distances not exceeding 150 feet on each side of crossing. Ground conductor shall consist of No. 8 AWG solid copper wire. Grounding electrodes shall be 3/4-inch by 10-foot-long copper-clad steel rod. Electrodes shall be driven into the earth so that the top of the electrode is at least 6 inches below the grade. Where driving is impracticable, electrodes shall be buried a minimum of 12 inches deep and radially from the fence. The top of the electrode shall be not less than 2 feet or more than 8 feet from the fence. Ground conductor shall be clamped to the fence and electrodes with bronze grounding clamps to create electrical continuity between fence posts, fence fabric, and ground rods. After installation the total resistance of fence to ground shall not be greater than 25 ohms. Each gate panel shall be bonded with a flexible bond strap to its gate post.

SECTION 02921

SEEDING

PART 1 GENERAL

1.1 DESCRIPTION OF WORK

This section covers seeding of disturbed areas.

PART 2 PRODUCTS

2.1 SEED, MULCHING, AND FERTILIZER

1. All areas defined shall be leveled and graded for application of seed, limestone, mulch, and fertilizer in accordance with NYSDOT Specifications Section 610 Turf and Wildflower Establishments.
2. Fertilizer shall meet NYSDOT 713-03, Type No. 2, 1-1-1, and shall be applied at the rate of 120 lb/acre. Another analysis, in the same ratio, may be used by varying the application rate to produce the same values specified. In addition, 2 tons/acre of agricultural lime shall be applied, in accordance with NYSDOT 713-02.
3. Seed shall be thoroughly mixed and evenly sown at a rate of 150 lb/acre over the prepared areas. Seed may be sown hydraulically. Seed mixture shall be as shown below:

Name	Percent of Mix
K-31 Tall Fescue	30
Creeping Red Fescue	25
Annual Rye	20
Timothy	12
Bluegrass	10
White Clover	3

2.2 TOPSOIL

When available, the topsoil shall be the existing surface soil stripped and stockpiled onsite in accordance with Section 02230 CLEARING AND GRUBBING. Topsoil shall be free from slag, cinders, stones, lumps of soil, sticks, roots, trash or other material over a minimum 1-1/2 inch diameter. Topsoil shall be free from viable plants and plant parts and meet the following requirements:

Organic content	> 3%
Silt fraction	25-50%
Clay fraction	0-30%
Sand fraction	20-35%
PH	5.0-7.6
Soluble salts	<600ppm

PART 3 EXECUTION

3.1 SEEDING, MULCHING AND FERTILIZER

3.1.1 Seeding Time

Seeding can be done between 1 April and 15 June or between 15 August and 1 October. Seeding time other than the above shall require the approval of the Engineer.

3.1.2 Application

Fertilizer, mulch, and seed shall be applied in accordance with NYSDOT Sections 610-3.02, Established Turf, and Method No. 1, Ground Preparation. Care During Construction shall conform to Method No. 1.

All finished areas, including berms and ditches, shall be seeded at intervals and in accordance with the Contract Documents or as directed by the Engineer.

Mulching material shall be in accordance with NYSDOT 713-18 and/or 713-19 and evenly placed over all seeded areas in accordance with NYSDOT 713-12. Mulch shall be straw applied at the approximate rate of 2 tons/acre.

3.2 WATERING SEED

Hydromulch shall be applied at 1,200 lbs/acre. During dry conditions, in lieu of hydromulch, use straw at 3,000 lbs/acre with tackifier.

Watering shall be started immediately after completing the seeding of an area. Water shall be applied to supplement rainfall at a rate sufficient to ensure moist soil conditions to a minimum 1 inch depth. Run-off and puddling shall be prevented. Watering trucks shall not be driven over turf areas.

Attachment A

Special Conditions for Work on Electric Transmission Rights of Way

ATTACHMENT "A"

SPECIAL CONDITIONS FOR WORK ON
ELECTRIC TRANSMISSION RIGHTS OF WAY

1. The work conducted on an electric transmission right of way or easement (collectively referred to hereinafter as "ROW") shall be performed in compliance with the High Voltage Proximity Act. GRANTEE shall take all necessary steps to insure that minimum line clearances are maintained by all persons, equipment, and vehicles entering the Property as follows:

Voltage	Minimum Clearance
50 Kv or less	10 feet
115 Kv	15 feet
230 Kv	17 feet
345 Kv	20 feet

2. All Equipment which is operated under or near any electrical conductors shall be effectively grounded as follows:

GROUNDING SPECIFICATIONS

Extreme caution shall be exercised while working in the vicinity of Niagara Mohawk Power Corporation's electric transmission towers, poles and/or underground facilities so as not to diversely affect, in any manner whatsoever, the structural stability of said towers and/or facilities. All equipment used in the work area which could approach nearer than twenty-five feet (25') to an energized electric power line or power facility, located overhead or underground, shall be grounded in order to protect persons and property. A good ground connection shall be securely attached to all equipment utilized at the work site and shall not be removed until the boom or any other substantial extension of all mobile equipment has been removed from the area of the work. All equipment used to make grounds shall be furnished at the sole cost and expense of the party performing the work, who shall also be responsible for determining the adequacy of all grounding arrangements utilized in the work area. However, the minimum steps that must be taken to effectively ground all equipment utilized in the work area are as follows:

- 1) All such equipment shall be provided with a permanent clamp for convenient and effective attachment to a grounding conductor.

- 2) The cable connecting the clamp to an adequate ground shall be equivalent to a No. 2/0 AWG or larger copper cable approximately 50 to 100 feet long, extra flexible, with 600 volt covering for abrasive protection and with terminal parts that will ensure a proper connection.

3) Station grounds, water hydrants, metallic pipe water systems, common neutral wire or steel tower earth footings provide grounds that are likely to be adequate in order of preference listed. When such grounds are not available, anchor rods, temporarily driven, or auger-type grounds shall be used to secure a low-resistance ground.

The above-mentioned recommendations are suggested by Niagara Mohawk Power Corporation as minimum requirements only; a Niagara Mohawk Power Corporation Inspector will review compliance with these minimum requirements prior to commencement of construction of activities on said premises.

3. Equipment which has the capability of extending within the wire clear zone established in Paragraph 1 above shall have a warning sign attached identifying the potential hazard.
4. No equipment utilized in site preparation grading, etc. shall be operated within ten (10) feet of any transmission line supporting structure.
5. There shall be no changes in grade within the right of way unless approved by **GRANTOR**.
6. UFPO (800-962-7962) shall be notified two days prior to any excavation specifically for, but not limited to, the purpose of identifying and locating the **GRANTOR**'s facilities or underground facilities of other parties. The **GRANTEE** shall use extreme caution during excavation and installation of the facilities such that the **GRANTOR**'s facilities are not disturbed. The **GRANTEE** shall be responsible for all repair costs of damages incurred which are a result of the installation of the facilities or their future maintenance.
7. All soil not used to backfill the excavation shall be removed from the ROW and disposed of in accordance with applicable regulatory requirements.
8. There shall be no blasting on the ROW.
9. The site preparation procedures shall include no activities which cause material to migrate or be placed or disposed off the boundaries of **GRANTOR**'s ROW.
10. No activities shall be permitted which compromise the electrical or structural integrity of overhead transmission facilities.
11. **GRANTOR** reserves the right to review any construction drawings and specifications as well as review and inspect the activities being carried on with ROW.
12. Markers shall be placed on each side of the ROW locating the buried facilities.
13. There shall be no excavation under the overhead lines within fifteen feet of the nearest wood member or guy anchor and/or twenty-five feet of the nearest steel member of a transmission line supporting structure.
14. No structures of any kind shall be constructed on the ROW.
15. The Superintendent of Area Transmission and distribution shall be notified in writing ten (10) days before any work is started on the ROW. The address is:

Superintendent T & D
Niagara Mohawk Power Corporation
Electric Operations Headquarters
300 Erie Boulevard West
Syracuse, New York 13202

16. If any terms or provisions of this Attachment are inconsistent with the Agreement, the terms and conditions of the Agreement shall have precedence.

Appendix D
Design Calculations



Project Witmer Road Landfill Closure Project No. 12040.65.0005
Subject Final Cover System Veneer Stability Calculations Sheet No. 1 of 5
Drawing No. _____
Computed by MJG Date 3/20/00 Checked by SD Date 3/21/00

OBJECTIVE:

Calculate the required peak friction angle between critical capping components to achieve a factor of safety of 1.5 for veneer stability.

PROCEDURE:

Use methodology presented by the Environmental Protection Agency (EPA) in *Stability of Lined Slopes at Landfills and Surface Impoundments* (1990). Calculate the factor of safety based on infinite slope and finite slope theory. Finite slope theory considers the buttressing effect of the toe of the landfill and results in a higher factor of safety.

The critical interfaces (those with the lowest expected friction angles based on manufacturer's literature) are evaluated on the steepest slopes of the final cover and on the top of the cap.

See attached sheets for veneer stability calculations.

CONCLUSIONS:

The VLDPE/geocomposite interface must have a peak friction angle of 13° for a minimum finite slope factor of safety of 1.59 on the 6H:1V side slopes. Based on manufacturer's data, this is not an achievable peak interface friction angle. **Textured VLDPE will be specified on the landfill side slopes with a minimum friction angle of 13°.** ✓

Assuming the cover soil is saturated, the stability of the top of the cap was calculated. On the 4 percent slopes, a minimum friction angle of 8° is required to achieve a factor of safety of 1.69. **Therefore, smooth VLDPE will be specified for the top of the landfill with a minimum friction angle of 8°.** ✓

The geocomposite/soil interface must have a peak friction angle of 13° for a minimum finite slope factor of safety of 1.57. Based on manufacturer's data, this is an achievable peak interface friction angle. ✓

**WITMER ROAD LANDFILL CLOSURE
LANDFILL CAP SLOPE STABILITY ANALYSIS
TRIAL FAILURE PLANE: 40-mil VLDPE/Nonwoven Needle-Punched Geotextile**

interface cohesion, c =	0 psf	
interface friction angle, ϕ =	13 °	Peak value (from GSE)
slope, z =	6 H:1V	
slope, β =	9.46 °	
length of slope, L =	70 ft	
unit weight of soil, γ =	120 pcf	
depth of soil, D =	1.5 ft	
pore pressure, μ =	0 in. water	
	0 psf	
toe soil cohesion, c_s =	0 psf	Silty sand
toe soil friction angle, ϕ_s =	26 °	Silty sand
weight of toe, W_T =	810 lb/ft	

INFINITE SLOPE FACTOR OF SAFETY:

$$F.S. = \frac{(\gamma D \cos \beta - \mu) \tan \phi + c}{\gamma D \sin \beta}$$

F.S. = 1.39

Reference: Stability of Lined Slopes at Landfills and Surface Impoundments, August 1990 (Equation 5).

FINITE SLOPE FACTOR OF SAFETY:

$$F.S. = \frac{(\gamma D \cos \beta - \mu) L \tan \phi + c L + \frac{W_T \tan \phi_s + c_s L}{\cos \beta - \sin \beta \tan \phi}}{\gamma D L \sin \beta}$$

F.S. = 1.59

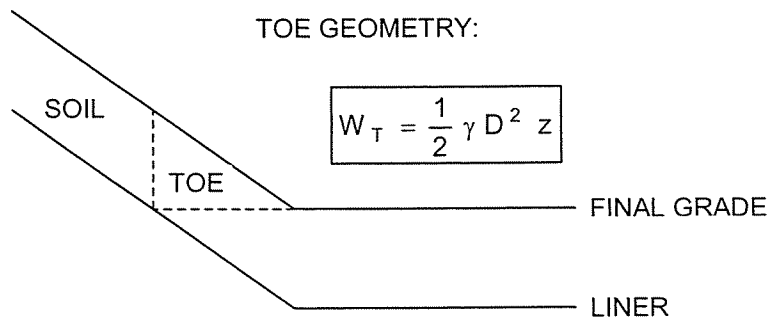

Reference: Stability of Lined Slopes at Landfills and Surface Impoundments, August 1990 (Equation 9).

**WITMER ROAD LANDFILL CLOSURE
LANDFILL CAP SLOPE STABILITY ANALYSIS
TRIAL FAILURE PLANE: Nonwoven Needle-Punched Geotextile/Soil**

interface cohesion, c =	0 psf	
interface friction angle, ϕ =	13 °	Peak value (from GSE)
slope, z =	6 H:1V	
slope, β =	9.46 °	
length of slope, L =	70 ft	
unit weight of soil, γ =	120 pcf	
depth of soil, D =	1.5 ft	
pore pressure, μ =	0.35 in. water	
	1.82 psf	
toe soil cohesion, c_s =	0 psf	Silty sand
toe soil friction angle, ϕ_s =	26 °	Silty sand
weight of toe, W_T =	810 lb/ft	

INFINITE SLOPE FACTOR OF SAFETY:

$$F.S. = \frac{(\gamma D \cos \beta - \mu) \tan \phi + c}{\gamma D \sin \beta}$$

F.S. = 1.37

Reference: Stability of Lined Slopes at Landfills and Surface Impoundments, August 1990 (Equation 5).

FINITE SLOPE FACTOR OF SAFETY:

$$F.S. = \frac{(\gamma D \cos \beta - \mu) L \tan \phi + c L + \frac{W_T \tan \phi_s + c_s L}{\cos \beta - \sin \beta \tan \phi}}{\gamma D L \sin \beta}$$

F.S. = 1.57

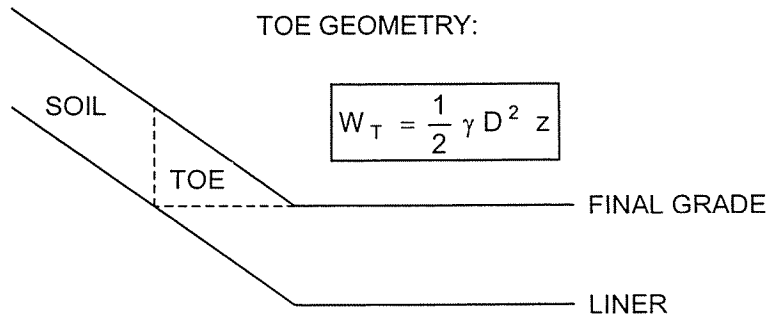

Reference: Stability of Lined Slopes at Landfills and Surface Impoundments, August 1990 (Equation 9).

**WITMER ROAD LANDFILL CLOSURE
LANDFILL CAP SLOPE STABILITY ANALYSIS
TRIAL FAILURE PLANE: 40-mil VLDPE/Nonwoven Needle-Punched Geotextile**

interface cohesion, c =	0 psf	
interface friction angle, ϕ =	8 °	Peak value (from GSE)
slope, z =	25 H:1V	
slope, β =	2.29 °	
length of slope, L =	430 ft	
unit weight of soil, γ =	120 pcf	
depth of soil, D =	1.5 ft	
pore pressure, μ =	18 in. water	
	93.6 psf	
toe soil cohesion, c_s =	0 psf	Silty sand
toe soil friction angle, ϕ_s =	26 °	Silty sand
weight of toe, W_T =	3375 lb/ft	

INFINITE SLOPE FACTOR OF SAFETY:

$$F.S. = \frac{(\gamma D \cos \beta - \mu) \tan \phi + c}{\gamma D \sin \beta}$$

F.S. = 1.69

Reference: Stability of Lined Slopes at Landfills and Surface Impoundments, August 1990 (Equation 5).

FINITE SLOPE FACTOR OF SAFETY:

$$F.S. = \frac{(\gamma D \cos \beta - \mu) L \tan \phi + c L + \frac{W_T \tan \phi_s + c_s L}{\cos \beta - \sin \beta \tan \phi}}{\gamma D L \sin \beta}$$

F.S. = 2.22

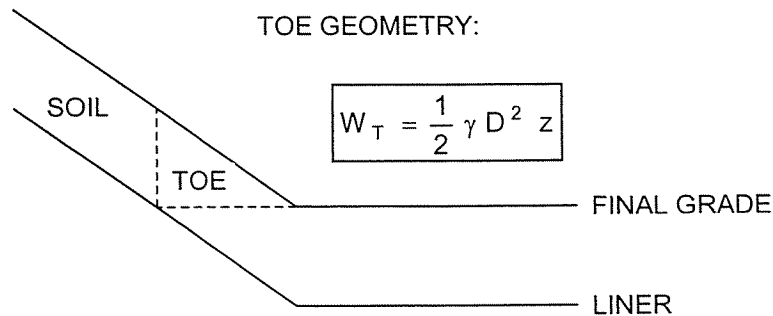

Reference: Stability of Lined Slopes at Landfills and Surface Impoundments, August 1990 (Equation 9).

**WITMER ROAD LANDFILL CLOSURE
LANDFILL CAP SLOPE STABILITY ANALYSIS
TRIAL FAILURE PLANE: Nonwoven Needle-Punched Geotextile/Soil**

interface cohesion, c =	0 psf	
interface friction angle, ϕ =	8 °	Peak value (from GSE)
slope, z =	25 H:1V	
slope, β =	2.29 °	
length of slope, L =	430 ft	
unit weight of soil, γ =	120 pcf	
depth of soil, D =	1.5 ft	
pore pressure, μ =	18 in. water	
	93.6 psf	
toe soil cohesion, c_s =	0 psf	Silty sand
toe soil friction angle, ϕ_s =	26 °	Silty sand
weight of toe, W_T =	3375 lb/ft	

INFINITE SLOPE FACTOR OF SAFETY:

$$F.S. = \frac{(\gamma D \cos \beta - \mu) \tan \phi + c}{\gamma D \sin \beta}$$

F.S. = 1.69

Reference: Stability of Lined Slopes at Landfills and Surface Impoundments, August 1990 (Equation 5).

FINITE SLOPE FACTOR OF SAFETY:

$$F.S. = \frac{(\gamma D \cos \beta - \mu) L \tan \phi + c L + \frac{W_T \tan \phi_s + c_s L}{\cos \beta - \sin \beta \tan \phi}}{\gamma D L \sin \beta}$$

F.S. = 2.22

TOE GEOMETRY:

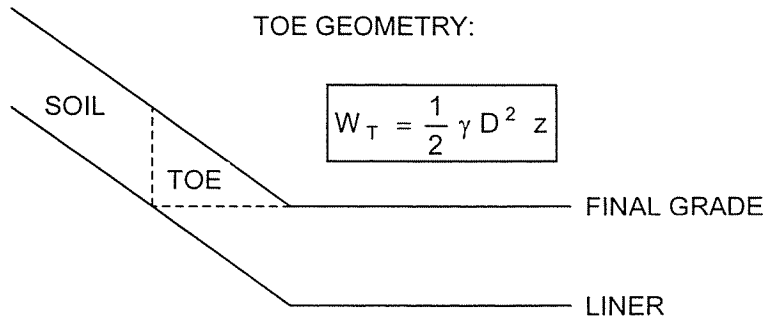

Reference: Stability of Lined Slopes at Landfills and Surface Impoundments, August 1990 (Equation 9).



Project Witmer Road Landfill Closure Project No. 12040.65.0005
Subject Barrier Protection Layer Requirements Sheet No. 1 of 1
Based on Geotextile Filter Drawing No. _____
Computed by DOK Date 3/10/00 Checked by MJA Date 3/21/00

OBJECTIVE:

Determine the requirements for the barrier protection layer material based on the apparent opening size (AOS) of the geotextile component of the geocomposite drainage collection layer. Specify a barrier protection layer material which will minimize clogging of the geotextile and piping into the drainage layer.

PROCEDURE:

Use Carroll's criteria to determine the smallest acceptable d_{85} for the barrier protection layer soil.

$$d_{85} \geq \frac{O_{95}}{2}$$

where:

O_{95} = apparent opening size of geotextile (AOS)

d_{85} = 85% of the barrier protection layer soil is smaller than this diameter (mm)

$$d_{85} \geq \frac{O_{95}}{2} \geq \frac{0.21 \text{ mm}}{2} \geq 0.105 \text{ mm}$$

RESULTS:

The d_{85} of the soil barrier protection layer must be $> 0.105 \text{ mm}$

Koerner, R.M. (1998).
Designing With Geosynthetics, Fourth Edition. Prentice Hall. Upper Saddle River, NJ.

Carroll, R.G., Jr. (1983).
"Geotextile Filter Criteria,"
Engineering Fabrics in Transportation Construction. TRR 916, TBR, Washington, D.C.

Tenax Tenflow 70CN-2



OBJECTIVE:

Determine the flow capacity of the geocomposite drainage layer in the landfill cap.

PROCEDURE:

- 1) Determine the flow of water infiltrating into the drainage layer based on the barrier protection layer's drainage properties and the slope geometry.

$$Q_{in} = k_{veg} * L * i \quad (\text{assumes saturation})$$

where:

Q_{in} = flow of water infiltrating into a unit width of drainage composite

k_{veg} = permeability of cover soil = 1×10^{-4} cm/sec

L = length of drainage composite = 130 m

$$Q_{in} = 1 \times 10^{-4} \text{ cm/sec} * 130 \text{ m} * (1 \text{ m}/100 \text{ cm}) = 1.3 \times 10^{-4} \text{ m}^2/\text{sec}$$

- 2) Determine the flow capacity of the drainage layer based on the geocomposite's drainage properties and the slope geometry.

$$Q_{out} = k_g * i * A = k_g * i * (t * 1) = (k_g * t) * i = \theta_{all} * i$$

θ_{all} = required transmissivity of the geocomposite

$$= \theta_{ultimate} / (RF_{in} * RF_{cr} * RF_{cc} * RF_{bc})$$

i = gradient = landfill side slope = 0.33 on south side

$\theta_{ultimate}$ = ultimate transmissivity = 1.5×10^{-3} m²/sec

RF_{in} = reduction factor for elastic deformation = 1.4

RF_{cr} = reduction factor for creep deformation = 1.3

RF_{cc} = reduction factor for chemical clogging = 1.1

RF_{bc} = reduction factor for biological clogging = 1.3

$$Q_{out} = [(1.5 \times 10^{-3} \text{ m}^2/\text{sec}) / (1.4 * 1.3 * 1.1 * 1.3)] * 0.33 = 1.90 \times 10^{-4} \text{ m}^2/\text{sec}$$

TENAX "Issues on Geocomposite Drainage Systems in Landfills (1998) TTR:DE17

Req'd in specifications From final grading plan

From final grading plan Transnet 250-2-H060



Project Witmer Road Landfill Project No. 12040.65.0005
Subject Cap Geocomposite Drainage Layer Capacity Sheet No. 2 of 2
Drawing No. _____
Computed by DOK Date 03/13/00 Checked by MJD Date 4/21/00

3) Calculate the factor of safety for the drainage capacity, FS_{dc} , of the geocomposite drain.

$$F.S._{dc} = \frac{Q_{out}}{Q_{in}} = \frac{1.90 \times 10^{-4}}{1.30 \times 10^{-4}} = 1.46$$

CONCLUSION:

The drainage layer geocomposite has sufficient capacity to transmit the infiltration through the barrier protection layer on the landfill side slopes.