

FINAL ENGINEERING REPORT
For
LOVE CANAL
BLACK AND BERGHOLTZ CREEKS
REMEDICATION

City of Niagara Falls, New York
Site Number 9-32-020



*Record
Document*

Prepared for:

NEW YORK STATE
DEPARTMENT OF ENVIRONMENTAL CONSERVATION
50 WOLF ROAD, ALBANY, NEW YORK 12233

THOMAS C. JORLING, COMMISSIONER

DIVISION OF HAZARDOUS WASTE REMEDIATION
MICHAEL J. O'TOOLE, JR., P.E., DIRECTOR

OCTOBER 1990

TAMS Consultants, Inc. - New York, N.Y.
Goldberg-Zoino Associates of New York, P.C. - Buffalo, N.Y.

**BLACK AND BERGHOLTZ CREEKS REMEDIATION
FINAL ENGINEERING REPORT**

TABLE OF CONTENTS

- 1. INTRODUCTION**
 - 1.1 BACKGROUND
 - 1.2 PROJECT OBJECTIVES
- 2. BIDDING PROCESS AND SELECTION**
- 3. CONTRACTOR PERSONNEL ORGANIZATION**
- 4. SUBCONTRACTED WORK**
 - 4.1 APPROVED SUBCONTRACTORS
 - 4.2 SUMMARY OF M/WBE UTILIZATION GOALS
 - 4.3 TABLE OF CONTRACTOR EQUIPMENT
 - 4.4 TABLE OF MATERIAL SUPPLIERS
- 5. EXECUTION AND SIGNIFICANT CHANGES**
 - 5.1 MOBILIZATION
 - 5.2 PSA CONSTRUCTION
 - 5.3 DCF AND FORCE MAIN CONSTRUCTION
 - 5.4 DDSF CONSTRUCTION
 - 5.5 MONITORING WELL CONSTRUCTION
 - 5.6 DEWATERING FACILITY RENOVATION
 - 5.7 CREEK REMEDIATION
 - 5.7.1 Sewer Cleaning
 - 5.7.2 Creek Excavation and Backfill
 - 5.7.3 Pedestrian Bridge
 - 5.6.4 Cribwall
 - 5.8 SCHEDULE
- 6. COST**
 - 6.1 ACTUAL QUANTITIES AND COSTS
 - 6.2 CHANGE ORDERS
 - 6.3 CLAIMS

1. INTRODUCTION

1.1 BACKGROUND:

In 1978 the New York State Department of Health (DOH) declared a state of emergency at Love Canal in response to the effects of chemically contaminated leachate carried to the surface at Love Canal. The leachate was dispersed from Love Canal through sanitary and storm sewers to other locations, including Black and Bergholtz Creeks via the storm sewer system. Among the most hazardous chemicals contained in the leachate at Love Canal is 2, 3, 7, 8 -TCDD (Dioxin); which has a tendency to adhere to sediment particles and migrate with sediment during transport associated with sewer or riverine hydraulics.

During early January 1983, field investigations conducted by a Remedial Investigation/Feasibility Study (RI/FS) sampling team confirmed the presence of dioxin and other contaminants in the bed sediments of Black and Bergholtz Creeks. The RI/FS report was accepted by the New York State Department of Environmental Conservation (NYSDEC); however, the United States Environmental Protection Agency (USEPA) determined that additional cost evaluations, risk assessments, and technical studies of remedial measures were required. Therefore, the original RI/FS was augmented with more technical design analyses. The resulting studies were accepted by the USEPA, and a Record of Decision (ROD) was issued in May 1985; describing a cleanup plan that includes dredging of contaminated sediments from the beds of Black and Bergholtz Creeks and construction of an interim containment facility for the sediments.

In October 1985 the Division of Solid and Hazardous Waste of the NYSDEC requested proposals for the Design and Construction Oversight for the Black and Bergholtz Creeks Remediation, Love Canal, City of Niagara Falls, N.Y. TAMS Consultants, Inc. was selected to perform the work and NYSDEC awarded the contract on July 23, 1986.

1.2. PROJECT OBJECTIVES:

This project involved the construction of a dewatering containment facility (DCF) for storage of dioxin-contaminated creek sediments and construction debris; construction of a decontamination/drum storage facility (DDSF); and excavation of the creek sediment. The sediment and other waste materials to be stored in the dewatering containment facility (DCF) were to be destroyed at a future time using a transportable thermal destruction unit (see: Section 5 - Execution and Significant Changes - page 17).

The sections of creeks to be cleaned included: approximately 3,150 feet of Bergholtz Creek from about 150 feet above its confluence with Black Creek to its confluence with Cayuga Creek and the above ground portion of the Black Creek from the twin-culverts at 98th Street to its confluence with the Bergholtz Creek. Under this project there were five primary tasks to be completed as follows:

- Task A: Construction, filling and closure of the dewatering containment facility (DCF)
- Task B: Construction of the decontamination/drum storage facility (DDSF)
- Task C: Removal and disposal of Black and Bergholtz Creek Sediments
- Task D: Cleaning of the storm sewers with outfalls leading into the creeks within the area to be remediated and rehabilitation of the 93rd Street sanitary sewer beneath the Bergholtz Creek bed.
- Task E: Rehabilitation and use of the existing dewatering facility located near 100th Street within the fenced area of the Love Canal site.

The detailed description of the above tasks was as follows:

TASK A - DEWATERING CONTAINMENT FACILITY (DCF)

The DCF will be constructed to store wastes (primarily creek sediments) resulting from the remediation of the creeks and other work items comprising the Project.

Construction of the DCF shall be completed prior to the start of any activity involving handling of any contaminated materials from Tasks C, D and E which will be stored in the DCF.

DCF construction will involve:

- Clearing and grubbing and other miscellaneous site work
- Utility relocation and abandonment
- Topsoil and overburden excavation (the by-products to be spread and seeded at the designated location at the Love Canal Site)
- Excavation of rubble and debris contained in the basements of former homes which are located at the proposed DCF location (the by-products to be containerized and stored for disposal in the DCF)
- Construction of permanent staging area (PSA)
- Construction of the landfill with attendant concrete work and mechanical and electrical systems, including clay and synthetic liners, leak detection and leachate collection systems pumps stations, force mains, underdrains, fences, access roads and other related work
- Filling the DCF
- Closure of the DCF

The work will also include abandonment of designated existing monitoring wells, installation of monitoring wells and integration of the leachate collection system into the NYSDEC Leachate Treatment Facility at the Love Canal Site.

TASK B - DECONTAMINATION/DRUM STORAGE FACILITY (DDSF)

The DDSF will consist of a pre-engineered building, to be selected and built by the Contractor. The DDSF will include a storage area for drums containing hazardous materials, a separate facility for future decontamination of equipment used at the Love Canal Site and control room and emergency shower. Features of the work to be performed for DDSF construction include:

- Clearing and grubbing.
- Excavation of topsoil and overburden (the by-products to be spread and seeded at the designated location at the Love Canal Site).
- Excavation of rubble and debris contained in the basements of former homes which are located at the proposed DDSF location (the by-products to be stored for disposal in the DCF).
- Backfill of excavated materials with structural fill.
- Construction of the DDSF; the building features include:
 - approximate dimensions 60 ft. x 160 ft.
 - reinforced concrete slab on grade
 - overhead rolling doors comprising the east and west walls
 - paved access road on fill along the building perimeter
 - storage area separated from the decontaminated area by partition wall
 - control room and emergency shower attached to the building
 - drainage trench in the building leading to an outside pump to be connected to NYSDEC Leachate Treatment Facility at the Love Canal Site.

TASK C - REMOVAL AND DISPOSAL OF CREEK BED MATERIALS (Creek Remediation)

Features of the Creeks Remediation work include:

- Erection of security fencing, decontamination facilities and demarcation fencing along creek banks.
- Clear and grub access routes and stockpile area.
- Construction of haul routes to edges of creeks.
- Construction of Short Term dewatering facilities near the creeks.
- Installation of bypass facilities and installation of a Silt Screen in Cayuga Creek at confluence with Bergholtz Creek.
- Construction divided into at least three reaches.
- Construction of cofferdams at various stages of the creek remediation activities.
- For each reach, the remediation procedure will consist of:
 - dewatering reach and construction of haul road on creek bed
 - excavation of creek bed material, side slopes and haul roads within the Remediation Zone and removal to the DCF
 - placement of clean fill material on creek bed.
- Remove and replace bulkhead at designated location.
- Replace footbridge at 93rd Street.
- Restore normal creek flows by discontinuing pumping and removing bypass pumps, piping and turbidity barrier.
- Restore Remediation Zone by removing access routes and demarcation fencing.
- Clean site, remove decontamination facilities and security fencing.
- Restore landscape and repair roadways along designated haul routes.

TASK D - SEWER CLEANING

This work will include:

- Cleaning storm sewers from the last manhole or catch basin to the outlet in the creeks within the Project Site.
- The total length of sewers to be cleaned is approximately 1,000 ft.
- The sewer diameters vary from 12 to 27 inches.
- Install flap valves on each sewer outlet.
- Television inspection of sewers shall be performed upon completion.
- Rehabilitation of 93rd Street sanitary sewer.

The work shall be performed when the appropriate section of the creeks has been dewatered and prior to creek cleaning.

TASK E - USE AND REHABILITATION OF NYSDEC'S DEWATERING FACILITY

This work will involve:

- Cleaning sediment from the existing facility and disposing of it in the DCF.
- Replacing bottom filter and rehabilitating the facility for safe operation during performance of other construction activities including disposal of decontamination water and, if necessary, water from dewatering creek.
- Cleaning the facility during the work, as required, and after completion of creek remediation. Sediments resulting from the cleaning shall be disposed of in the DCF.
- Replacing piping and mechanical components as required for future use at the Love Canal Site.

Supplemental work that was necessary to obtain the primary project objectives included the following:

- Provide and maintain site facilities such as engineer's offices, contractor's offices, security and communications operations, equipment decontamination facilities, personnel hygiene and recreation facilities, emergency medical facility and parking areas.

- Provide, operate and maintain temporary site utilities including telephone, electricity, water and sanitation.
- Prepare, submit, and implement a quality control plan, a health and safety plan, a spill control plan methods statement, and activity hazardous analysis (Phase Plan) for each feature of the work and all necessary documentation for transporting wastes from their point of origin to the DCF.
- Install and maintain a weather station, and collect data.

2. PROJECT BID PROCESS AND AWARD

The project contract went out to bid on December 17, 1987. A mandatory pre-bid meeting and site visit was held on Thursday, January 7, 1988 at the Frontier Fire Hall for all bidders, the engineer assisted the NYSDEC in answering questions raised by perspective bidders and also described the project features.

The following potential bidders were represented at the pre-bid meeting:

- Westinghouse Environmental Technology
- IT Corporation
- Roy F. Weston
- CECOS
- Riedel Environmental Services, Inc.
- Scrufari Construction Co.
- SOS Environmental
- Sevenson Construction Corp.
- Sicali and Massaio
- Kimmins
- Herbert F. Darling, Inc.
- SLC Consultants/Construction

During the bidding period, two addenda were issued to the potential bidders. These addenda mainly presented minor technical clarifications.

Sealed proposals were received by the New York State Department of Environmental Conservation Office of Fiscal Management until 3:00 P.M. Wednesday, February 10, 1988. Formal bids were received from Sevenson Environmental Services and Westinghouse Inc. Upon analysis of bids and the overall construction costs it was determined that Sevenson Environmental Services has the lowest responsible bid in the amount of twelve million, two hundred and eighty nine thousand, two hundred and fifty dollars (\$12,289,250.00). Westinghouse Inc. submitted a bid in the amount of \$22,097,617.00. The NYSDEC awarded the contract to Sevensen Environmental on April 1, 1988.

3. CONTRACTOR PERSONNEL ORGANIZATION

The functional responsibilities of contractor key technical personnel at the site are summarized below with a organizational flow chart attached.

Project Manager: Kim W. Lickfield

- Corporate quality control and quality assurance;
- Managerial guidance to technical group;
- Technical representation at meetings;
- Liaison between technical group and client.

Quality Control Supervisor: William Beck (1988):
Jerry Castiglione (1989):

- Ensure total compliance of the field work to project specifications;
- Prepare, submit and maintain daily and weekly project submittals to the Engineer;
- Maintain project schedule.

Health and Safety Officer: Paul Hitcho, Ph.D., CIH

- Development and implementation of the Health and Safety Plan;
- Preconstruction indoctrination of all on-site personnel;
- Review and revise Health and Safety Plan as necessary;
- Oversee Site Safety Officer's activities.

Site Safety Officer: Dana Tipton

- Implement and monitor Health and Safety Plan on a daily basis;
- Conduct Air Monitoring Program;
- Review and Report Analytical Results.

Project Superintendent: Salvatore Sparatorio (1988)
Frank Fracassi (1989)

- Responsible for all site construction activities;
- Coordination of subcontractor activities;
- Ensure compliance of the field work to the project specifications.

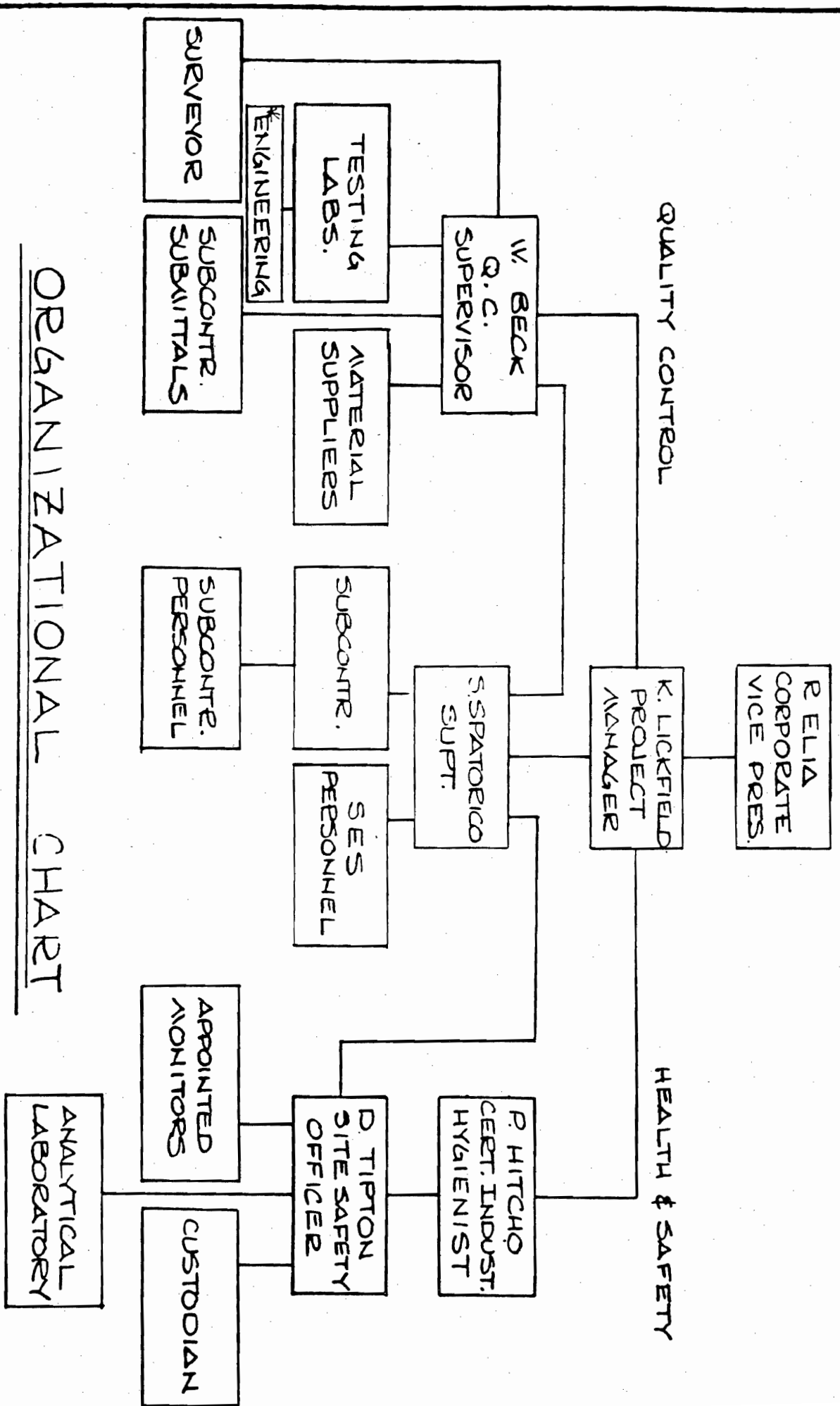

ORGANIZATIONAL CHART

LOVE CANAL - BLACK & BERGHOLTZ CREEK
 REMEDIATION
 NYSDEC CONTRACT NO. D001939

*INCLUDING
 PROFESSIONAL ENGINEERS

KVL

4. SUBCONTRACTOR WORK

4.1 APPROVED SUBCONTRACTORS

The following list of approved subcontractors in accordance with Article 17 - Subcontractors of the general conditions were used by the general contractor to accomplish their respectively described work tasks for the project.

<u>SUBCONTRACTOR</u>	<u>WORK</u>
- FOX FENCE INC. 4205 Hyde park Boulevard Niagara Falls, New York	Fence Work, Sections 02101 and 02110
- INNOVATIVE ERECTING 29 Grant Street Lockport, New York	DDSF Building Structure, Section 13125--Erection
- VAUGHAN DOOR CENTER, INC. 2925 Military Road Niagara Falls, New York	DDSF Building Structure Section 13125--O.H. Doors
- G & D CONSTRUCTION AND SUPPLY, INC. 932 Kenmore Avenue Buffalo, New York 14216	Field Painting Section 13125
- IN-COM ELECTRICAL CONS- TRUCTION COMPANY, INC. 1067 Harlem Road Buffalo, New York 14227	Electrical Work
- GUNDLE LINING CONSTR. CORP. 19103 Gundle Road Houston, Texas 77073	HDPE Liners Sections 01400, 02220 and 02400
- JOHN W. DANFORTH COMPANY 1940 Fillmore Avenue Buffalo, New York 14214	Bypass Piping Installation NYSDEC Temporary Dewatering Facility Inspection, Rehabilitation
- MERIT PAVING INC. 4817 Henry Avenue Niagara Falls, N.Y. 14304	Asphalt Work DDSF Area and Permanent Staging Area
- MARTIN BLACKTOP & CONSTR. 3631 Chapin Avenue Niagara Falls, New York	Asphalt Work TDF Area

SUBCONTRACTOR

WORK

- SELECT ENVIRONMENTAL SERVICES, INC.
2235 West Harrison Street
Chicago, Illinois 60612

Section 13510
Section 13520
Clean and Televisive

- INSTITUFORM - METROPOLITAN
446 West 34th Street
New York, New York 10001

Rehab of the 93rd
Street Sewer
Section 13520

- C.P. WARD, INC.
800 Ridge Road, West
Rochester, New York 14615

Sheet Pile Cofferdam
Sheet Pile at the
Crib Wall
H-Pile Installation
for the Pedestrian
Bridge Section 02476

- CABLE GUIDE RAILING
CONSTRUCTION COMPANY
89 Brandel Avenue
Lancaster, New York 14086

Cribbing
Section 02270

- G & J CONTRACTING
5140 Walmore Road
Sanborn, New York 14132

Reinforcing
Steel Erection
Section 03300

- REPUBLIC PAINTING, SHEETING
& BUILDING CORP.
4242 Ridge Lea Road
Amherst, New York

DDSF Field
Painting
Section 13125

4.2 SUMMARY OF M/WBE UTILIZATION:

The final project M/WBE participation for the project is summarized as follows:

<u>CONTRACT AMOUNT</u>	<u>15% MBE GOAL</u>	<u>5% WBE GOAL</u>
\$12,289,250.00	\$1,843,388.00	\$ 614,463.00
<u>TOTAL MBE PARTICIPATION</u>		
G, & J Contracting		\$ 18,590.00
In-Com Electrical		176,190.32
Martin Blacktop and Construction Co.		41,250.00
Pavilion Drainage Supply Co.		79,817.00
Select Environmental Services		108,164.00
Velco Sheet Metal		5,274.96
Comet Flasher Services		<u>505.90</u>
	TOTAL	\$429,792.18
	GOAL	\$1,843,388.00
	Percent Achieved	23.3%
<u>TOTAL WBE PARTICIPATION</u>		
Doran Trucking Company		\$203,873.11
Dobmeier Janitor Supply		3,716.91
Innovative Building		46,996.85
Republic Painting		10,558.00
Linda Rocco Photography		8,308.43
Vaughan Door Center		53,414.00
Wilson Brothers Trucking		<u>19,300.44</u>
	TOTAL	\$346,167.74
	GOAL	\$614,463.00
	Percent Achieved	56.3%

Table 4.3

CONTRACTOR EQUIPMENT

<u>NUMBER</u>	<u>DESCRIPTION</u>
(1)	Komatsu D 68 E Dozer
(2)	Komatsu D 65 E Dozer
(2)	Komatsu D 31 E Dozer
(2)	Komatsu D 37 E Dozer
(1)	Dresser TD 15 Dozer
(1)	I.H. Dozer
(1)	J.D. 850 Dozer
(1)	J.D. 400 Dozer
(1)	P & H 115 T Truck Crane
(1)	P & H 70 T Truck Crane
(2)	I-R Sheepsfoot Roller
(2)	I-R Smooth Drum Roller
(1)	Komatsu 993 B Track Loader
(1)	Cat 950 Loader
(1)	Komatsu WA 200 Loader
(1)	Komatsu WA 70 Loader
(1)	Yutani 400 Backhoe
(1)	Komatsu 400 Backhoe
(3)	Komatsu 200 Backhoe
(1)	Komatsu PC 90 Backhoe
(1)	Komatsu PC 30 Backhoe
(1)	B-E 190 Dymahoe
(1)	Mack Water Truck
(1)	Road Broom
(1)	JCB 530 B Forklift
(1)	Ingersoll Rand Compress
(1)	York Rake
(1)	Read Screen All
(2)	5000 Gallon Tank
(1)	3500 Gallon Tank
(1)	Ice Hammer
(2)	Honda 5000 Generator
(2)	Yamaha 5000 Generator
(1)	Miller Welder
(2)	3" Stow Pump
(2)	3" Honda Pump
(6)	2" Tsurumi Pump
(1)	Safety Van
(1)	Water Treatment Tran.

Table 4.4

<u>SUPPLIER</u>	<u>MATERIAL</u>
NIAGARA STONE CORP 8875 Quarry Road Niagara Falls, New York	Drainage Stone, Filter Stone, Bedding Stone, Riprap, Subbase Stone, Type Z Fill, Asphalt
EMPIRE BUILDERS SUPPLY New Road Niagara Falls, New York	Concrete
GUNDLE LINING CORPORATION 19103 Gundle Road Houston, Texas	HDPE Liners (Type I, II & III)
GERNATT PRODUCTS, INC. Richardson Road Collins, New York	Sand
KISTNER CONCRETE PRODUCTS, INC. 8713 Read Road East Pembroke, New York	Catch Basins
FORT MILLER COMPANY, INC. 55690 Camp Road Hamburg, New York	Manholes
CABLE GUIDE RAILING, INC. 89 Brandel Avenue Lancaster, New York	Concrete Precast Cribbing
CONTINENTAL CUSTOM BRIDGE Alexandria, Minnesota	Pedestrian Bridge
FRONTIER METAL BUILDINGS (Straw Building) 1926 New Jersey Avenue Niagara Falls, New York	DDSF Building
PHILLIPS DRISCOPIPE, INC. 2929 North Central Expressway Houston, Texas	High Density Polyethylene -PVC Pipe and Fitting
BUFFALO TANK CORPORATION Division/U.S. Steel Corp. 1900 Frankfurst Avenue Baltimore, Maryland	10,000 Gallon Tank

PHILLIPS FIBERS CORPORATION
P.O. Box 66
Greenville, South Carolina

Filter Fabric, Geotextile

HASELY FARM
Niagara County

Topsoil, Clay,
Suitable Material

5. EXECUTION AND SIGNIFICANT CHANGES

5.1 MOBILIZATION:

The New York State Department of Environmental Conservation awarded the contract on April 1, 1988. Shortly thereafter the contractor mobilized by constructing the project field office and staging area at the 93rd Street schoolyard location. Major work items were site survey, fence, installation, clearing and grubbing, office trailer's set-up, utility installation, access roads and parking lot. The contractor also conducted a road condition survey including photographs and video of local streets that would possibly be used by construction vehicles during the creek cleaning project.

The contractor then proceeded to build the temporary dewatering facility and a decontamination pad at the 93rd Street school site. Preparation work (i.e. clearing and grubbing, demarcation and perimeter fence work, access roads, staging area and by-pass pipeline grading) for the creeks remediation followed.

The contractor's Health and Safety Plan final approval on June 27, 1988 allowed the Contractor to proceed with hazardous work at both the Love Canal Work Area and the Black & Bergholtz Creek's Remediation Area.

The contractor also proceeded with submittals for review and approval including: construction schedule, quality control plan, material sources and test data, health & safety plan, work methods and proceedings, shop drawings, equipment manufacturers, list of subcontractors, etc.

5.2 PERMANENT STORAGE AREA:

The PSA construction at the southeast corner of 95th Street and Read Avenue started in August, 1988 with site work (temporary fence relocation, clearing and grubbing, utility relocation, well abandonment) then proceeded with basement hazardous excavations which were placed in sealed 30 yd containers, tarped and stored on TSA-1. Basements were then backfilled and subgrade, base and surface asphalt courses placed for PSA pad. Construction was completed September, 1988.

A total of 9 basements were excavated in order to construct the PSA Pad. They were house No. 822, 826, 830, 834, 838, 842, 846, 850, & 856. The measured and paid quantity was 1861 CY YD. [Item I-5] which included excavation to top of basement floor*. Basement floor concrete was broken, then basement wall sections were placed flat on slab to reduce containerized (landfill) yardage. The measured and paid backfill quantity for these nine basements was 1158 CY of bedding stone [Item I-6].

* Basement debris was excavated in entirety due to instability of material excavated to support PSA design loads [Engineers Direction].

Problems encountered during construction were: (1) The recharging of basement excavations due to ground water from abandoned sewers. (2) Capping of additional monitoring wells found during subgrade preparation. (3) Utility conflicts during storm sewer installation. (4) Location & abandonment of existing water service in 95th Street main. The above resulted in issuance of Change Orders No. 3 & 4.

5.3 DDSF CONSTRUCTION:

The start of DDSF construction was March, 1989. Site work included the excavation and backfill of (6) basements [5 below building foundation and (1) additional for driveway construction]. The pre-engineered metal building manufactured by Stran Buildings was 60' x 65' x 16' in final approved dimensions.

Prior to award of Contract No. D-001939, the office of the state controller ruled that the DDSF structure qualified as a "Building", thereby according to section 135 of State Finance Law it required preparation of separate contract documents and bids for the Mechanical and Electrical work associated with DDSF. Therefore the interior mechanical and electrical work was deleted from Main Contract, bid and awarded as separate contracts to Ferguson Electric (Electric Contract No. D-002097 and to Severson Environmental Services (Mechanical Contract No. D-002099). A portion of the exterior mechanical and electrical work for the DDSF including excavation and backfill was reinserted into and made part of this contract by Change Order No. One (see Section 6.2 for full description of change order).

Problems encountered during construction were: (1) Recharging of basement excavations with ground water from abandoned street sewer lines resulted in additional contractor costs. (2) Storm sewer conflict with building foundation resulted in relocating building 10' to the North. (3) Parking lot required design cross-section thickness construction interfered with existing love canal cap HDPE liner, resulting in parking lot redesign. These conflicts and unknown conditions resulted in time issuance of Change Order No. 10.

The DDSF Building general construction was substantially complete in November, 1989. The Mechanical and Electrical Contracts were substantial complete in March, 1990.

5.4 DCF AND FORCE MAIN CONSTRUCTION:

The DCF construction started in June, 1988 with temporary fence relocation, construction of 95th Street decon pad and clearing and grubbing operation at the Love Canal site. Then continued with topsoil removal, general excavation and access road installation on existing cap. Basement excavations for CDD cell area began in August. A total of 23 basements were excavated. SES proceeded to submit second source (Haseley site) for clay material approval during August, 1988 after original source (Indian Hill site) did not meet contract specifications nor appear to have sufficient quantity for project. Suitable material

placement for CDD cell began in late September, 1988. Contractor stopped construction in DCF area at end of November, 1988 due to weather and lack of approved material submittals. The 30 yard container and material movement from TSA to PSA continued through winter months. Construction of DCF resumed in March, 1989.

The NYSDEC stopped construction of CDD cell portion of DCF facility on June 30, 1989 as a result of agreement with Occidental Chemical Corporation for final disposition of creek sediments. Design modification were made in July which included the deletion of construction demolition debris (CDD) cell, addition of an internal berm in the DCF cell to subdivide the cell into two subareas identified as subarea "A" and "B" and installation of manhole #15 with an interim valve in the leachate transfer system to limit leachate from subarea "B" from backing into subarea "A" during storm events. Subarea "A" (Northern end) of the DCF was designed to store the demolition debris initially intended to be placed in the CDD cell and subarea "B" southern end) as a contingency area to temporarily hold contaminated creek sediments at times when OCC might be unable to accept waste.

The DCF facility was substantially complete, ready to accept waste by the end of August, 1989. After it was ascertained by NYSDEC that OCC's bagging facility would function as designed contractor began to fill subarea "A" with the containerized construction demolition debris stored on the PSA. Total fill quantity was 6670 cy. The DCF was then capped with clay and closed by November 15, 1989. Subarea "B" remained open.

Construction problems encountered during construction of DCF were: (1) NYSDEC's withholding of progress payments for contractor's non-compliance with the Affirmative Action requirements of contract resulted in SES physical work stoppage during November and December of 1988. Work resumed after SES was informed by the NYSDEC that this action was a material breach of Contract (reference section 0082.3 of Contract Documents) and after the Bureau of Affirmative Action was able to clarify their position. (2) The original approved contract schedule of May, 1988 was revised in September, 1988 and then further revised in February of 1989. This last revision was never approved by the owner/engineer since the submitted schedule indicated two sets of contract completion dates: December 1989 and June 1990.

The elimination of the CDD cell portion resulted in a net cost savings of \$470,000 calculated from the unit price schedule of adjusted quantities that were directly related to the construction of the DCF. The DCF modification resulted in a cost increase of \$213,127 (Change Order No. 18). Additional change orders associated with the DCF construction were numbers 7, 15, 16 and 21. (see section 6.2).

The force main construction from DDSF building to the Love Canal leachate treatment facility was started and completed in late fall of 1989. The work was accomplished by a time and material change order which resulted from the legal requirements of Wick's Law that had made

it necessary to modify the prime contract. (Change Order No. 1-Section 6.2). A design change was made to the containment envelope of force main due to space constraints and high water table for trench excavation. This design change consisted basically of using a double wall pipe within a 40 mil HDPE liner instead of original 2.5' feet of clay incasement for secondary leachate containment.

Construction problems encountered during construction of Force Main were: (1) Extreme weather conditions. (2) Constant dewatering. (3) Physical constraints of excavation. (4) Increased material and labor costs, as a result of design change. These problems resulted in cost overruns of \$145,849.00 above the negotiated cost estimate of \$239,407.00 (Change Order 20, see Section 6.2).

5.5 MONITORING WELL ABANDONMENT/CONSTRUCTION:

Plans called for the abandonment and/or extension of designated existing monitoring wells and the installation of 62 monitoring wells around the DDSF and CDD cells and across the eastern side of the existing cap. There were 39 well abandonment/extensions at a cost of \$11,700.00. The 62 wells consisted of 19 well clusters and 3 single wells. As work progressed a number of modifications were made to the installation and development of the wells: only 58 wells were installed for a total of 1415 linear feet. In addition, some bedrock wells were installed as triple-cased, telescoping monitoring wells. The double cased wells were covered by change order No. 5.

Details of the monitoring well program, including modifications and procedures used for installation and development are described in a report titled "Monitoring Well Installation Report for Love Canal - Black and Bergholtz Creeks Remediation."

5.6 DEWATERING FACILITY RENOVATION:

The rehabilitation of facility was accomplished as per specification. After the (4) tanks were dewatered, contaminated sludge material (approximately 360 cy) was removed by clam bucket and hand excavation. It was then transported in 30 yd (14) containers to OCC for processing at the Tricel Bagging Facility. Final cleaning was done by vacuum truck. Tank liners were inspected, patched and hydrostatically tested, before installation of new fabric and filter sand. Due to the weathered and deteriorated condition of covers, NYSDEC elected to replace with new 20 Mil PVC floating covers manufactured by Modutank Inc. Total cost for labor and materials was \$9,040.00.

Additional work included replacing existing truck discharge with a decontamination pad, replacement of two secondary tank discharge pumps, repair/replacement of piping, valves, supports, etc. for mechanical system and renovation of north and south sand filter tanks. Total payment for this task was item D-19 in the amount of \$22,624.00.

5.7 CREEK REMEDIATION:

5.7.1 Sewer Cleaning: A total of eleven storm sewers that discharged into the scheduled remediation reaches A, B, & C of Black & Bergholtz Creeks were cleaned by a high pressure sewer jetting machine capable of 80 gallon per minute at a pressure of 2000 PSI. The storm sewers that varied from 12 inch to 27 inch in pipe diameter were cleaned from the upstream manhole to the down stream pipe discharge location. The work was accomplished by Select Environmental Services during the last week of July and the first week of August in 1989. All the storm sewer lines were then color televised using a VHS recorder with written television inspection reports provided (see appendix A). After the creek remediation was complete Severson Environmental Service installed Neenah Automatic Drainage Gates for each outlet as an "approved equal" to the specified flap valves.

The rehabilitation of the 93rd Street sanitary sewer was accomplished by the insituform process in lieu of the HDPE sliplining as originally specified. The process basically consists of inverting a polyester fiber felt tube into sewer line, then heating with hot water the impregnated liquid thermosetting resin to bond and strengthen existing pipe wall. The work was accomplished by Insituform-Metropolitan of New York City. The rehabilitated length was 172 linear feet of 14 inch diameter steel pipe. A television inspection was made before and after the remediation on September 19, 1989.

5.7.2 Creek Excavation and Backfill: Most construction activities associated with this task were accomplished as per design. Preparation work including demarcation fence & security fence installation, clearing and grubbing, nonhazardous access and haul road construction and 30" steel bypass pipeline construction for Bergholz Creek were accomplished in 1988. Also Easements and Map preparation was accomplished by TAMS Consultants and the NYSDEC obtained temporary usage and restoration agreements from individual property owners along creeks. The primary up-stream Bergholz intake concrete chamber (6' x 16') was designed with (2) 8" and (2) 12" Flygt submersible centrifugal pumps capable of pumping 30 CFS at 40 feet of head. A 5th Flygt 8" standby pump was installed in a 6' x 6' concrete chamber. Pump controls were automatic with recording flow meter and alarms. Stand-by generator was provided. Black Creek upstream bypass pumping consisted of (2) 6" Flygt pumps (installed in a 6' x 6' concrete chamber) that were capable of pumping 4 CFS at 32 feet of head. The water from Black Creek was diverted upstream of Bergholtz cofferdam by use of a 10" diameter PVC by-pass pipe line.

The contractor then proceeded with construction of upstream primary earth cofferdams (2) and downstream primary steel sheetpile cofferdam at the confluence of Bergholtz and Cayuga Creeks. After dewatering a specific reach of creek a 20' wide haul road was constructed on existing insitu creek subgrade using a bottom layer of unwoven GTF 130 P geotextile, a top layer of woven Exxon GTF 300 geotextile, 69 inches of 2" well graded ROC and top course of 9-12 inches 2" max aggregate. Road

was design to support a 40 ton tandem axle truck. Creek material below elev. 562.0 were excavated to a minimum depth of 12" using a backhoe, loaded on tandem dump trucks, deconned upon exit from remediation zone. Excavated material then transported to TDF (Temporary Dewatering Facility), processed by OCC (Oxidental Chemical Corporation) bagging facility and finally transported and stored at Oxy Buffalo Ave plant. A total of 12,493 cy of contaminated material was excavated from the 3 designated reaches A, B, & C. Secondary cofferdam and haul road material was removed as contaminated excavation proceeded in creek.

Creek bed gravel then was placed on geotextile using tandem dump trucks accessing stream bed from 'clean' portion of reach. Material was graded using bulldozer. A total of 9,350 cy of gravel and 1937 cy of topsoil were placed.

Occidental Chemical Corporations's (OCC) involvement in project also resulted in changes in the scope of work for remediation of Black & Bergholtz Creeks in addition to previous noted changes for DCF Task (ref. section 5.4). The major modifications were : (1) OCC's bagging and processing plant built at the 93rd street site eliminated - SES handling of contaminated creek sediments on TDF, Decon of trucks, transportation of materials to Love Canal DCF, and Demolition/Removal of TDF. (2) OCC removed stored drums from Love Canal site and processed contents at bagging facility there by eliminating SES's contract task of handling and placement in DCF. (3) NYSDEC requested miscellaneous Love Canal site debris be placed in DCF by SES. (4) Required that all SSDF contaminated material be transported to OCC facility instead of placement in DCF.

The above outlined major modifications and several other items were negotiated between NYSDEC and SES at job meetings and through correspondence. A tentative "no cost" agreement was made between the parties on March 22, 1990. A final agreement was reached on May 31, 1990 after the NYSDEC deducted an amount of \$10,000 from contract for SES not having to remove the TDF.

Major construction problems encountered during this task were: (1) Difficulty in the closure of downstream primary sheetpile cofferdam at confluence with Cayuga Creek (see Change Order No. 8). (2) Removal of unknown wooden piles at 91st Street bridge (see Change Order No. 17). (3) Required extensions of 94th Street storm sewer (see Change Order No. 19).

5.7.3 Pedestrian Bridge: The 85' long x 6' wide pedestrian bridge was supplied by Continental Custom Bridge Co. and erected by Project General Contractor in the fall of 1989. Bridge design was self-weathering structural steel rectangular tube structural tube arch truss with timber deck. An existing utility conflict with sanitary and storm sewers at 93rd Street resulted in the revision of bridge location and elevation change of bottom of footing.

5.7.4 **Cribwall:** The replacement of timber bulkhead along South bank of Bergholtz Creek at 91st Street bridge was accomplished by installing a 7' high crib-type retaining wall approximately 134' long. Material and installation was provided by Canle Guide Railing Construction Co. Inc. in the Fall of 1989. (Pay Item No. II - 17).

Construction problems encountered were: (1) Upon review of soil conditions it was determined that the existing soft, silty clay layer which underlie the timber bulkhead had to be excavated to a competent foundation in order to prevent a general soil bearing capacity failure and replaced with a selected gravel backfill before cribwall could be constructed. (2) Proximity of existing house foundation created problem for sheetpile installation and removal. (See Change Order No. 14, Section 6.2).

The contractor then proceeded with construction of upstream primary earth cofferdams (2) and downstream primary steel sheetpile cofferdam at the confluence of Bergholtz and Cayuga Creeks. After dewatering a specific reach of creek a 20' wide haul road was constructed on existing insitu creek subgrade using a bottom layer of unwoven GTF 130 P geotextile, a top layer of woven Exxon GTF 300 geotextile, 69 inches of 2" well graded ROC and top course of 9-12 inches 2" max aggregate. Road was design to support a 40 ton tandem axle truck. Creek material below elev. 562.0 were excavated to a minimum depth of 12" using a backhoe, loaded on tandem dump trucks, deconned upon exit from remediation zone. Excavated material then transported to TDF (Temporary Dewatering Facility), processed by OCC (Occidental Chemical Corporation) bagging facility and finally transported and stored at Oxy Buffalo Ave plant. A total of 12,493 cy of contaminated material was excavated from the 3 designated reaches A, B, & C. Secondary cofferdam and haul road material was removed as contaminated excavation proceeded in creek.

Creek bed gravel then was placed on geotextile using tandem dump trucks accessing stream bed from 'clean' portion of reach. Material was graded using bulldozer. A total of 9,350 cy of gravel and 1937 cy of topsoil were placed.

Occidental Chemical Corporations's (OCC) involvement in project also resulted in changes in the scope of work for remediation of Black & Bergholtz Creeks in addition to previous noted changes for DCF Task (ref. section 5.4). The major modifications were : (1) OCC's bagging and processing plant built at the 93rd street site eliminated - SES handling of contaminated creek sediments on TDF, Decon of trucks, transportation of materials to Love Canal DCF, and Demolition/Removal of TDF. (2) OCC removed stored drums from Love Canal site and processed contents at bagging facility there by eliminating SES's contract task of handling and placement in DCF. (3) NYSDEC requested miscellaneous Love Canal site debris be placed in DCF by SES. (4) Required that all SSDF contaminated material be transported to OCC facility instead of placement in DCF.

The above outlined major modifications and several other items were negotiated between NYSDEC and SES at job meetings and through correspondence. A tentative "no cost" agreement was made between the parties on March 22, 1990. A final agreement was reached on May 31, 1990 after the NYSDEC deducted an amount of \$10,000 from contract for SES not having to remove the TDF.

Major construction problems encountered during this task were: (1) Difficulty in the closure of downstream primary sheetpile cofferdam at confluence with Cayuga Creek (see Change Order No. 8). (2) Removal of unknown wooden piles at 91st Street bridge (see Change Order No. 17). (3) Required extensions of 94th Street storm sewer (see Change Order No. 19).

5.7.3 Pedestrian Bridge: The 85' long x 6' wide pedestrian bridge was supplied by Continental Custom Bridge Co. and erected by Project

General Contractor in the fall of 1989. Bridge design was self-weathering structural steel rectangular tube structural tube arch truss with timber deck. An existing utility conflict with sanitary and storm sewers at 93rd Street resulted in the revision of bridge location and elevation change of bottom of footing.

5.7.4 **Cribwall:** The replacement of timber bulkhead along South bank of Bergholtz Creek at 91st Street bridge was accomplished by installing a 7' high crib-type retaining wall approximately 134' long. Material and installation was provided by Canle Guide Railing Construction Co. Inc. in the Fall of 1989. (Pay Item No. II - 17).

Construction problems encountered were: (1) Upon review of soil conditions it was determined that the existing soft, silty clay layer which underlie the timber bulkhead had to be excavated to a competent foundation in order to prevent a general soil bearing capacity failure and replaced with a selected gravel backfill before cribwall could be constructed. (2) Proximity of existing house foundation created problem for sheetpile installation and removal. (See Change Order No. 14, Section 6.2).

6.1 ACTUAL QUANTITIES AND COSTS

PROJECT: LOVE CANAL, BLACK AND BERGHOLTZ CREEK REMEDIATION
 CONTRACTOR: SEVENSON ENVIRONMENTAL SERVICES, INC.
 ENGINEER: TAMS CONSULTANTS, INC.
 N.Y.S.D.E.C. Contract No. D001939

ITEM NO.	D E S C R I P T I O N	QUANTITY and UNIT	UNIT PRICE (DOLLARS)	SCHEDULE VALUE (DOLLARS)	TOTAL UNIT	QUANTITY & UNIT PRICE (DOLLARS)
C-1	Project Mobilization	Lump Sum	1,725,000.00	1,725,000.00	100%	1,725,000.00
C-2	Site Preparation Exclusion and Remediation Zones	Lump Sum	1,100,000.00	1,100,000.00	99.1%	1,090,000.00
C-3	Site Services	Lump Sum	1,700,000.00	1,700,000.00	99.9%	1,698,754.00
C-4	Project Site Restoration	Lump Sum	100,000.00	100,000.00	100%	100,000.00
<u>P a r t I</u>						
<u>FENCING, UTILITIES, WELLS</u>						
I-1	Fence Removal & Installation	Lump Sum	80,000.00	80,000.00	100%	80,000.00
I-2	Utility Abandonment Relocation and Modifications	Lump Sum	85,000.00	85,000.00	100%	85,000.00
I-3	Well Abandonment & Extensions	36 Each	300.00	10,800.00	39 Ea	11,700.00
I-4	Well Installation	1,590 LF	100.00	159,000.00	1415.1 LF	141,510.00
<u>EARROWORK</u>						
I-5	Basement Excavation Below Elevation 570.5	6,000 CY	120.00	720,000.00	6670.1 CY	800,412.00
I-6	Basement Backfill	2,800 CY	40.00	112,000.00	5198.4 CY	207,936.00
<u>S u b t o t a l</u>						5,940,312.00
<u>T O T A L</u>						5,940,312.00

PROJECT: LOVE CANAL BLACK AND BERGHOLTZ CREEK REMEDIATION

CONTRACTOR: SEVENSON ENVIRONMENTAL SERVICES, INC.

ENGINEER: TAMS CONSULTANTS, INC.

N.Y.S.D.E.C. Contract No. D001939

ITEM NO.	D E S C R I P T I O N	QUANTITY and UNIT	UNIT PRICE (DOLLARS)	SCHEDULE VALUE (DOLLARS)	TOTAL UNIT	QUANTITY & UNIT PRICE (DOLLARS)
I-7	General Excavation	6,000 CY	5.00	30,000.00	9387 CY	46,935.00
I-8	Dewatering-DCF Area	Lump Sum	46,000.00	46,000.00	100%	46,000.00
I-9	Clay	81,000 CY	8.00	648,000.00	59,176 CY	473,408.00
I-10	Bedding Stone	4,200 CY	25.00	105,000.00	10.5 CY	262.50
I-11	Drainage Stone	27,500 CY	30.00	825,000.00	17,493 CY	524,790.00
I-12	Suitable Material	26,000 CY	8.00	208,000.00	33,891 CY	271,128.00
I-13	Riprap	1,400 CY	30.00	42,000.00	396.9 CY	11,907.00
I-14	Topsoil and Seed	6,700 CY	10.00	67,000.00	6473.2 CY	64,732.00
LINERS AND FILTERS						
I-15	HPDE Liner, Type I	47,000 SY	9.00	423,000.00	42,848 SY	385,632.00
I-16	Filter Fabric	34,000 SY	2.00	68,000.00	29,808 SY	59,616.00
I-17	Geotextile	90,000 SY	2.00	180,000.00	81,638 SY	163,276.00
Subtotal						0.00
TOTAL						7,987,998.50

PROJECT: LOVE CANAL BLACK AND BERGHOLTZ CREEK REMEDIATION
 CONTRACTOR: SEVENSON ENVIRONMENTAL SERVICES, INC.
 ENGINEER: TAMS CONSULTANTS, INC.
 N.Y.S.D.E.C. Contract No. D001939

ITEM NO.	D E S C R I P T I O N	QUANTITY and UNIT	UNIT PRICE (DOLLARS)	SCHEDULE VALUE (DOLLARS)	TOTAL UNITS	QUANTITY & UNIT PRICE (DOLLARS)
<u>DRAINAGE</u>						
I-18	Toe Underdrain	800 LF	20.00	16,000.00	800 LF	16,000.00
I-19	Catch Basins	4 Each	1,000.00	4,000.00	5 Each	5,000.00
I-20	Storm Drainage Pipe	620 LF	35.00	21,700.00	658 L.F.	23,030.00
I-21	Manholes	16 Each	2,000.00	32,000.00	12 Each	24,000.00
<u>LEACHATE COLLECTION</u>						
I-22	Upper & Lower Leachate Collection Systems	1,660 LF	20.00	33,200.00	1330 LF	26,600.00
I-23	Upper & Lower Leachate Transfer Systems	1,300 LF	40.00	52,000.00	1157.2 LF	46,288.00
<u>PUMP STATIONS AND HOLDING TANK</u>						
I-24	Pump Stations No. 1, 2 & 3	Lump Sum	70,000.00	70,000.00	63.2%	44,240.00
I-25	Holding Tank & Pump Station #4	Lump Sum	80,000.00	80,000.00	100%	80,000.00
I-26	Force Main	770 LF	40.00	30,800.00	310 LF	12,400.00
<u>Subtotal</u>						277,558.00

T O T A L 8,265,556.50

PROJECT: LOVE CANAL BLACK AND BERGHOLTZ CREEK REMEDIATION
 CONTRACTOR: SEVENSON ENVIRONMENTAL SERVICES, INC.
 ENGINEER: TAMS CONSULTANTS, INC.
 N.Y.S.D.E.C. Contract No. D001939

ITEM NO.	D E S C R I P T I O N	QUANTITY and UNIT	UNIT PRICE (DOLLARS)	SCHEME VALUE (DOLLARS)	TOTAL UNITS	QUANTITY & UNIT PRICE (DOLLARS)
MISCELLANEOUS						
I-27	Subbase Stone	1,500 CY	20.00	30,000.00	1183 CY	23,660.00
I-28	Staging Area	Lump Sum	500,000.00	500,000.00	100%	500,000.00
I-29	Filter Stone	500 CY	30.00	15,000.00	104 CY	3,120.00
I-30	GAS Collection System	Lump Sum	30,000.00	30,000.00	81.6%	24,480.00
Part II						
DECONTAMINATION/DRUM STORAGE FACILITY						
II-1	DDSF Foundations, Pavement & Drainage	Lump Sum	500,000.00	500,000.00	100%	500,000.00
II-2	DDSE Building Superstructure	Lump Sum	175,000.00	175,000.00	100%	175,000.00
II-3	- - - Deleted - - -					
II-4	- - - Deleted - - -					
SEWER CLEANING						
II-5	Sewer Cleaning-Storm Sewers	Lump Sum	100,000.00	100,000.00	100%	100,000.00
II-6	Rehabilitation of 93rd Street Sanitary Sewer	Lump Sum	60,000.00	60,000.00	100%	60,000.00
Subtotal						1,386,260.00

ITEM NO.	DESCRIPTION	QUANTITY and UNIT	UNIT PRICE (DOLLARS)	SCHEDULE VALUE (DOLLARS)	TOTAL UNITS	QUANTITY & UNIT PRICE (DOLLARS)
CREEK REMEDIATION						
II-7	Access Roads	Lump Sum	120,000.00	120,000.00	100%	120,000.00
II-8	Cofferdams, Bypass Facilities, and Care of Water	Lump Sum	900,000.00	900,000.00	100%	900,000.00
II-9	Overtopping of Cofferdams	2 Each	50,000.00	100,000.00	0	
II-10	Removal of Material from the Remediation Zone	10,000 CY	40.00	400,000.00	12,493 CY	499,720.00
II-11	Removal of Concrete, Stone Protection and Debris	Lump Sum	30,000.00	30,000.00	100%	30,000.00
II-12	Creek Bed Gravel	7,200 CY	25.00	180,000.00	8,350.2 CY	208,755.00
II-13	Select Granular Fill	300 CY	35.00	10,500.00	50 CY	1,750.00
II-14	Topsoil and Seed	1,330 CY	25.00	33,250.00	1937.4 CY	48,435.00
II-15	Pedestrian Bridge	Lump Sum	55,000.00	55,000.00	100%	55,000.00
Subtotal						0.00
TOTAL						11,515,476.50

PROJECT: LOVE CANAL BLACK AND BERGHOLTZ CREEK REMEDIATION
 CONTRACTOR: SEVENSON ENVIRONMENTAL SERVICES, INC.
 ENGINEER: TAMS CONSULTANTS, INC.
 N.Y.S.D.E.C. Contract No. D001939

Final Quantities

Page 6 of 6

ITEM NO.	D E S C R I P T I O N	QUANTITY and UNIT	UNIT PRICE (DOLLARS)	SCHEMATIC VALUE (DOLLARS)	TOTAL UNITS TO DATE	QUANTITY & UNIT PRICE (DOLLARS)
II-16	Sewer Outfall Protection	3 Each	\$ 8,000.00	\$ 24,000.00	1 Each	8,000.00
II-17	Replacement of Timber Bulkhead at 91st Street	Lump Sum	100,000.00	100,000.00	100%	100,000.00
II-18	Waste Water Management-- All work required by Sections 02415 and 02416 of Specifications, Part II except Item II-19	Lump Sum	125,000.00	125,000.00	100%	125,000.00
II-19	Furnish, Deliver and Install New Materials; Test; Place in Operating Condition; Existing Dewatering Facility	Lump Sum	10,000.00	10,000.00	226.2%	22,624.02
II-20	Excavation of Miscellaneous Contaminated Material	600 CY	30.00	18,000.00	0	
Subtotal						0.00
TOTAL						11,771,100.52

6.2 CHANGE ORDERS

New York State Department of Environmental Conservation
 Black & Bergholtz Creeks Remediation - Change Order Log
 Severson Environmental Services, Inc., Contract # D001939
 Site # 9-32-020, Original Contract Amt. \$12,289,250.00

C.O. Number	Description	Date Approved	C.O. Amount	Actual cost	Difference	Comments
1.	DDFS Force Main	10/03/89	239407.00	385,256.00	145,849.00	TAMS verified costs
2.	Frontier Ave. Storm Sewer Abandonment - (void)		0.00	0.00	0.00	Deleted
3.	PSA Excavation Dewatering	03/11/89	15572.00	15572.00	0.00	Final
4.	95th Street Water Service Conflict	03/11/89	14675.00	14675.00	0.00	Final
5.	Telescoping Wells	04/06/89	44124.00	28694.54	(15,429.46)	Final
6.	MH Waterstops Pedestrian bridge handrail modifications, credit for concrete fence post footings, perimeter fencing change along Bergholtz	08/02/89	-41.00	-41.00	0.00	Final
7.	Vent Pipe Extension, Utility abandonment at the DCF	09/06/89	2751.00	2751.00	0.00	Final
8.	Reach B Haul Road Modifications	09/20/89	22158.00	22158.00	0.00	Final
9.	Telescoping Well Standby Costs	09/11/89	22440.00	22440.00	0.00	Final

TAMS

C.O. Number	Description	Date Approved	C.O. Amount	Actual Cost	Difference	Comments
10.	Revision of the DDFS Location and Catch Basin, DDSF Dewatering	12/12/89	26145.00	19427.00	(6,718.00)	TAMS verified costs
11.	Modification to Primary Sheet Pile Cofferdam	12/12/89	25000.00	18145.00	(6,855.00)	TAMS verified costs
12.	Utility conflict/ Dewatering for DCF Force Main at 97th and Wheatfield	12/12/89	15000.00	9598.00	(5,402.00)	TAMS verified costs
13.	Remediation of Reach "C"	11/16/89	20088.00	12546.00	(7,540.00)	TAMS verified costs
14.	Cribwall Foundation Replacement	11/16/89	57237.00	148972.55	91735.55	TAMS verified costs
15.	95th Street Fence Gates installations	12/05/89	2310.00	2310.00	0.00	Final
16.	Steel pipe coating at 10,000 gallon holding tank	12/19/89	151.25	151.25	0.00	Final
17.	Wooden Pile Removal at 91st Street bridge	12/19/89	4030.00	4030.00	0.00	Final
18.	DCF Modifications	04/19/90	220000.00	213127.00	(6,873.00)	TAMS verified costs
19.	94th Street Storm Sewer Extension	01/20/90	4200.00	3873.00	(327.00)	Final
20.	Contract Cost Adjustment		199,927.98	N/A	0.00	Final

TAMS

<u>C.O. Number</u>	<u>Description</u>	<u>Date Approved</u>	<u>C.O. Amount</u>	<u>Actual Cost</u>	<u>Difference</u>	<u>Comments</u>
21.	100th Street Stockpile	03/29/90	19377.00	19342.00	(35.00)	TAMS verified costs
22.	HDPE Liner Credit & DDSF Roof Fan Repair	10/10/90	- 1700.16	- 1700.16	0.00	Final
Totals			\$952852.07	\$941327.18	\$188403.09	

Original Contract Amount: \$ 12,289,250.00
Net Increase Due to Change Orders: \$ 952,852.07
Net Contract Amount: \$ 13,242,102.07

New York State Department of Environmental Conservation
Division of Hazardous Waste and Remediation

CHANGE ORDER

Date of Issue: August 16, 1989

Change Order No.: 1

Change Order Amount: \$239,407.00

Contract No.: D-001939

Project Name: Black and Bergholtz Creek Remediation,
Love Canal, Niagara County

NYSDEC Project No.: Site Number 9-32-020

Contractor's Name: Severson Environmental Services, Inc.

I. DESCRIPTION OF CHANGE

A portion of the exterior mechanical and electrical work for the Decontamination Drum Storage Facility (DDSF) including excavation and backfill, deleted by the Rider to Agreement Including Attachment No. 1 to Rider, as specifically defined hereinafter, is hereby reinserted into and made part of this Contract. The interior mechanical and electrical work within the DDSF and certain specified exterior mechanical work, remains deleted and is not part of this Contract.

IA. Mechanical Work Reinserted by this Change Order and made part of this Contract.

1. Drainage Piping

(a) Furnish and install all underground and below the floor slab 3-inch cast iron drainage pipe and fittings and steel pipe sleeve from the service sink area to the sump pit as shown on Contract Drawing No. 122. The drainage pipe at the service sink area shall terminate 4 inches above the floor slab and capped for future piping connection and to prevent the entrance of foreign objects.

(b) Furnish and install all underground 4-inch ductile iron drainage pipe and fittings and including steel pipe sleeves from the trench to the sump pit as shown on Contract Drawing No. 122 of the Contract.

2. Cold Water Service Piping

Furnish and install all underground and below the floor slab 1-inch pipe and fittings from the 1-inch service water valve located in the building to a connection point on the nearest existing active service water line as shown on Drawing No. 122 of the Contract.

3. Sump Pipe Discharge Piping, Force Main and Liner

- (a) Furnish and install all 4-inch cast iron pump discharge pipe and fittings and including steel pipe sleeve from the flange outlet of a 4-inch tee located inside the sump pit to the 4-inch underground high density polyethylene (HDPE) force main pipe terminating at a manhole located behind the Leachate Treatment Facility as shown on Contract Drawing Nos. 121 and 122.
- (b) Furnish and install HDPE liner for the underground force main from the sump pit to the manhole located behind the Leachate Treatment Facility as shown on Contract Drawing Nos. 121 and 122.

4. Sump Pit Vent Pipe

Furnish and install that portion of the 4-inch vent pipe that is embedded in concrete and extend 6 inches above the concrete top slab of the sump pit complete with a 4-inch slip-on flange and anchor bolts as shown on Contract Drawing No. 122.

IB. Electrical Work Reinserted by this Change Order and Made Part of this Contract.

1. Remove Existing Wires and Conduits including:

- (a) Disconnect gate intercom wiring at Administration Building.
- (b) Disconnect gate opener, power and control wiring at Administration Building.
- (c) Remove underground conduits from Administration Building to Read Avenue Gate as shown on Contract Drawing No. 121. Provide temporary power and control wiring to operate the gate from the Administration Building.

2. Furnish and install Underground Conduit.

- (a) Furnish and install underground empty conduits from the Administration Building to Pole P-1, to the Read Avenue Gate, and to the DDSF, and from the DDSF to the Read Avenue Gate, as shown on Contract Drawing No. 121.
- (b) Furnish and install pull boxes in the underground conduit runs as shown on Contract Drawing No. 121 and provide a 1/4 inch nylon drag line in each conduit.
- (c) Leave the pull boxes accessible for future cable installation.
- (d) The ends of all underground conduits installed, shall be terminated above ground with a threaded coupling and a watertight

cap. At the DDSF the conduits shall rise through and terminate above the floor slab.

IC. The above mechanical and electrical work includes excavation, backfill, supports, restoration of pavement and curbs, removal of water and incidentals required to complete the work.

DRAWINGS

Drawing 121, DDSF, Electrical/Mechanical Utilities

Drawing 122, DDSF, Electrical/Mechanical Utilities
Plans Details & Schedules

SPECIFICATION

The following Sections of the Specifications deleted by Rider to Agreement, Attachment No. 1, are hereby reinserted into the Specifications. The work under the Change Order shall conform to the applicable provisions of the following Sections.

DIVISION 15 - Mechanical (for DDSF) Reinserted Sections

<u>Section No.</u>	<u>Title</u>
15000	General Provisions - Mechanical
15050	Basic Materials and Methods - Mechanical
15400	Plumbing Systems
15880	DDSF Pump Station

DIVISION 16 - Electrical (for DDSF) Reinserted Sections

<u>Section No.</u>	<u>Title</u>
16000	Basic Materials and Methods - Electrical
16100	Conduits and Fittings
16131	Outlet, Junction and Pull Boxes
16740	Telephone and Telephone Conduit System

CONTRACT ITEMS: UNIT PRICE SCHEDULE AND SECTION 01800 - MEASUREMENT AND PAYMENT, OF THE SPECIFICATIONS

The following new Contract Items cover all the work required under this Change Order:

<u>Item No.</u>	<u>Description</u>	<u>Unit</u>
II-3A	Exterior DDSF Mechanical Work, Change Order No. 1	L.S.
II-4A	Exterior DDSF Electrical Work, Change Order No. 1	L.S.

Insert new measurement and payment paragraphs to replace paragraphs 39 and 40 (page 01800-14) deleted by Rider to Agreement Attachment No. 1, as follows:

"39. ITEM NO. II-3A: EXTERIOR DDSF MECHANICAL WORK - CHANGE ORDER NO. 1

"39.1 Measurement.

All exterior mechanical and related work for the DDSF as required by Change Order No. 1 acceptably constructed ready for use, will be measured as a complete unit.

"39.1 Payment.

Payment for the unit measured as provided above will be made on the basis of "...actual cost of labor and materials plus overhead and profit, cost to be determined as the work progresses..." in accordance with sub-article 11.4(d) of Section 0071.0 - General Conditions, except that the maximum limit of payment for completion of the entire work under the Item (all mechanical and related work) shall be the Contract price of \$166,907.00 for Item II-3A in this Change Order. Should the actual cost as determined above reach such amount and the work under the Item not be completed, the Contractor will be required to complete the work at no additional cost to the Department."

Actual cost records will be kept, even if the above amount is exceeded. Should the Engineer determine that the specified amount caused undo hardship to the Contractor, he will recommend to the Department an appropriate increase in the amount in accordance with the last sentence of Article 11.11.

"40. ITEM NO. II-4A: EXTERIOR DDSF ELECTRICAL WORK - CHANGE ORDER NO. 1

"40.1 Measurement.

All exterior electrical and related work for the DDSF as required by Change Order No. 1 acceptably constructed ready for use, will be measured as a complete unit.

"40.1 Payment.

Payment for the unit measured as provided above will be made on the basis of "...actual cost of labor and materials plus overhead and profit, cost to be determined as the work progresses..." in accordance with sub-article 11.4(d) of Section 0071.0 - General Conditions, except that the maximum limit of payment for completion of the entire work under the Item (all electrical and related work) shall be the Contract price of \$72,500.00 for Item II-4A in this Change Order. Should the actual cost as determined above reach such amount and the work under the Item not be completed, the Contractor will be required to complete the work at no additional cost to the Department.

Actual cost records will be kept, even if the above amount is exceeded. Should the Engineer determine that the specified amount caused undo hardship to the Contractor, he will recommend to the Department an appropriate increase in the amount in accordance with the last sentence of Article 11.11.

II. REASON FOR CHANGE:

At the direction of the Office of the State Controller, DHWR reviewed the Black and Bergholtz Creeks Remediation contract documents with NYSDEC counsel and it was determined that the pre-engineered structure, identified as the Decontamination Drum Storage Facility (DDSF), in the creek remediation contract documents qualified as a "building". Since the DDSF has been judged a "building", Section 135 of State Finance Law, which requires the preparation of separate plans and specifications and separate bidding of contracts for the plumbing, electrical and heating, ventilating and air-conditioning subdivisions of work for any building whose entire costs exceeds \$50,000, was deemed applicable.

To comply with this determination, prior to award of Contract No. D-001939, the NYSDEC deleted from the contract both the DDSF Mechanical Systems bid item, which included all plumbing work, and DDSF Electrical Systems bid item which includes all electrical work associated with this "building".

A portion of the exterior mechanical and electrical work for the Decontamination Drum Storage Facility (DDSF) including excavation and backfill, deleted prior to award as noted above, is hereby reinserted into and made part of Contract No. D-001939. The interior mechanical and electrical work within the DDSF and certain specific exterior mechanical work, remains deleted and is not part of this Contract.

Performance of this work under this Change Order is required in order for Contractor to commence work on the Staging Area which will need to

be done at the beginning of the project in order to complete the work within the Contract completion time.

III. CHANGE IN CONTRACT PRICE

Original Contract Price: \$12,289,250.00

Contract Price after previous Change Order: N/A

Net Maximum Increase due to this Change Order: \$239,407.00

Itemization:

<u>Item No.</u>	<u>Amount</u>
II-3A	\$166,907.00
II-4A	\$ 72,500.00

New contract price including this Change Order: To be determined based on amounts for Items II-3A and II-4A as per paragraphs 39 and 40. Maximum New Contract Price \$12,528,657.00.

IV. CHANGE IN CONTRACT CALENDAR DAYS COMPLETION DATE

Original Contract Time 625

Contract Time after
previous Change Order N/A

Net (INCREASE)
due to this Change Order: 0

New Contract Time including
this Change Order 625

It is understood and agreed that, unless expressly so stated above, the work herein authorized will not extend the time for the completion of the contract.

This work is to be performed in accordance with the terms of the contract and original plans and specifications, except as herein modified. It is understood and agreed that this order shall be deemed executory only to the extent of moneys available and no liability shall be incurred by the State beyond the moneys available for the purpose.

APPROVALS

Contractor (Print) Sevenson Environmental Services, Inc.

(Sign) _____ Title: Vice President

Date: _____

Engineer (Print) TAMS Consultants, Inc.

(Sign) _____ Title: Resident Engineer

Date: _____

NYSDEC/Division of Hazardous Waste Remediation

(Print) _____

(Sign) _____ Title: Acting Division Director

Date: _____

NEW YORK STATE DEPARTMENT OF ENVIRONMENTAL CONSERVATION

(Print) _____

(Sign) _____ Title: Director, Div. of Fiscal Mgmt.

Date: _____

For NYS Dept. of Audit and Control Approval

Date: _____

chord816.nol

New York State Department of Environmental Conservation
Division of Hazardous Waste and Remediation

CHANGE ORDER

Date of Issue: October 19, 1988

Change Order No.: 3

Change Order Amount: \$15,572.00

Contract No.: D-001939

Project Name: Black and Bergholtz Creek Remediation,
Love Canal, Niagara County

NYSDEC Project No.: Site Number 9-32-020

Contractor's Name: Severson Environmental Services, Inc.

I. DESCRIPTION OF CHANGE

- IA. Installation of vent plugs, (3) three in number, in monitoring wells located in the Permanent Staging Area.
- IB. Re-alignment of the (2) two 8" watermain conflicts as discovered on 95th Street. Relocation to remove the potential for interference between the existing waterline and the storm sewer pipe to be installed.
- IC. The abandonment of the utilities in the Permanent Staging Area that were not specified by or included in the contract.
- ID. Performance of dewatering operation for removal of a potential problem with an existing sanitary sewer located on the former 97th Street.
- IE. Installation of steel reinforcement in concrete that was placed, in the form of (2) two slabs, around storm manhole's #12 and #13.

DRAWINGS: N/A for IA,IB,IC,ID,IE above.

All work (AOBE) as ordered by the Engineer.

SPECIFICATION

All work completed under this change order shall conform to the general specifications as ordered by the Engineer/NYSDEC.

PAYMENT

Payment for the unit measured as provided above will be made on the basis of "...actual cost of labor and materials plus overhead and profit, cost to be determined as the work progresses..." in accordance with sub-article 11.4 (d) if Section 0071.0 - General Conditions.

II. REASON FOR CHANGE:

Work completed under this Change Order has been generated as follows:

- IA. The work completed under this item was recommended by NYSDEC for improvement as a condition that was considered to be potentially troublesome.
- IB. Discovery of an existing utility conflict forced the work to be done under this item. The city of Niagara Falls approved the relocation plan that was instituted.
- IC. The existence of some unknown conditions (i.e. additional utilities) generated the work that was conducted under this item.
- ID. Unknown conditions also generated the work completed under this item. The work conducted was ordered by the Engineer/NYSDEC.
- IE. The additional work generated under this item was AOB for increasing the structural stability of the item.

Performance of the work under this change order is necessary to allow the contractor to continue operations and complete the work within the contract time.

III. CHANGE IN CONTRACT PRICE

Original Contract Price: \$12,289,250.00

Contract Price after previous Change Order: N/A

Net Increase due to this Change Order: \$15,572.00

Itemization:

IA	Vent Plugs	\$ 910.00
IB	Waterline Relocation	\$ 8,685.00
IC	Utility Abandonment - PSA	\$ 2,227.00
ID	Dewatering 97th Street Sewers	\$ 3,586.00
IE	Steel Reinforcement	\$ 164.00

Total: \$15,572.00

IV. CHANGE IN CONTRACT CALANDAR DAYS COMPLETION DATE

Original Contract Time 625

Contract Time after
previous Change Order N/A

Net (INCREASE) (DECREASE)
due to this Change Order: 0

New Contract Time including
this Change Order 625

It is understood and agreed that, unless expressly stated above, the work herein authorized will not extend the time for the completion of the contract.

This work is to be performed in accordance with the terms of the contract and original plans and specifications, except as herein modified. It is understood and agreed that this order shall be deemed executory only to the extent of moneys available and no liability shall be incurred by the State beyond the moneys available for the purpose.

APPROVALS

Contractor (Print)

(Sign)

Title:

Date:

Engineer (Print)

(Sign)

Title: Section Chief

NYSDEC/Division of Hazardous Waste Remediation

(Print)

(Sign)

Title: Acting Division Director

Date:

NEW YORK STATE DEPARTMENT OF ENVIRONMENTAL CONSERVATION

(Print)

(Sign)

Title: Director, Div. of Fiscal Mgmt.

Date:

For NYS Dept. of Audit and Control Approval

Date:

New York State Department of Environmental Conservation
Division of Hazardous Waste and Remediation

CHANGE ORDER

Date of Issue: November 18, 1988

Change Order No.: 4

Change Order Amount: \$14,675.00

Contract No.: D-001939

Project Name: Black and Bergholtz Creek Remediation,
Love Canal, Niagara County

NYSDEC Project No.: Site Number 9-32-020

Contractor's Name: Severson Environmental Services, Inc.

I. DESCRIPTION OF CHANGE

The work accomplished under this change order included, but was not limited to, the location, exposure, and rectification of what the Owner believed to be a leaking water service on the east side of 95th Street, south of Read Avenue. The performance of this work was under the observation of the Owner and the Engineer.

DRAWINGS: As-built drawings provided by SES and entitled "Waterline Excavation - 10/26/88, 10/25/88, 10/24/88". All work (AOBE) as ordered by the Engineer.

SPECIFICATION

All work completed under this change order conformed to the general specifications as ordered by the Engineer/NYSDEC.

PAYMENT

Payment for the unit measured as provided above was made on the basis of "...actual cost of labor and materials plus overhead and profit, cost to be determined as the work progresses..." in accordance with sub-article 11.4 (d) of Section 0071.0 - General Conditions.

II. REASON FOR CHANGE:

During the progression of work through the Permanent Staging Area, a potentially troublesome problem was discovered. This problem was in the form of an unknown generator of free liquids that was encountered in the basement excavations. In order to alleviate this situation in consideration of future work operations, some investigation was performed by the Owner / Engineer and it was determined that the most likely source of the liquids would be a possibly leaking water service on 95th Street. Change Order No. 4 was initiated to conduct further investigation and/or rectify the situation.

III. CHANGE IN CONTRACT PRICE

Original Contract Price: \$12,289,250.00

Contract Price after previous Change Order: N/A

Net Increase due to this Change Order: \$14,675.00

IV. CHANGE IN CONTRACT

CALENDAR DAYS

COMPLETION DATE

Original Contract Time

625

Contract Time after
previous Change Order

N/A

Net (INCREASE) (DECREASE)
due to this Change Order:

\$14,675.00

New Contract Time including
this Change Order

625

It is understood and agreed that, unless expressly stated above, the work herein authorized will not extend the time for the completion of the contract.

This work was performed in accordance with the terms of the contract and original plans and specifications, except as herein modified. It is understood and agreed that this order shall be deemed executory only to the extent of moneys available and no liability shall be incurred by the State beyond the moneys available for the purpose.

APPROVALS

Contractor (Print)

(Sign)

Title:

Date:

Engineer (Print)

(Sign)

Title:

NYSDEC/Division of Hazardous Waste Remediation

(Print)

(Sign)

Title:

Date:

NEW YORK STATE DEPARTMENT OF ENVIRONMENTAL CONSERVATION

(Print)

(Sign)

Title:

Date:

For NYS Dept. of Audit and Control Approval

Date:

New York State Department of Environmental Conservation
Division of Hazardous Waste and Remediation

CHANGE ORDER

Date of Issue: , 1989

Change Order No.:

Estimated Change Order Amount: \$44,124.00 *

Contract No.: D-001939

Project Name: Black and Bergholtz Creek Remediation,
Love Canal, Niagara County

NYSDEC Project No.: Site Number 9-32-020

Contractor's Name: Severson Environmental Services, Inc.

I. DESCRIPTION OF CHANGE

The work to be executed under this change order is that additionally needed to complete six telescoping wells in accordance with the detail and direction given to the contractor by the Owner/Engineer. This work has been instituted to insure against any cross-contamination between geologic strata. The performance of this work shall be under the observation of the Owner and the Engineer.

DRAWINGS: "Telescoping Well Detail" Dated 1-17-89.

SPECIFICATION

All work to be completed under this change order shall conform to the contract specifications and/or as ordered by the Engineer/Owner.

MEASUREMENT

The unit of measurement shall be as follows for the various items:

	<u>ITEM</u>	<u>UNIT</u>
1.	17 inch Augering	Linear foot
2.	16 inch Pipe Grouted	Linear foot
3.	Additional 55 Gal. Drums	Each
4.	6 inch Pipe Grouted	Linear foot
5.	Additional Decons	Hour
6.	Material Handling-Drum	Each

PAYMENT

Payment for the units measured as provided previously will be made on the basis of "...acceptance of agreed unit prices based on estimated cost plus overhead and profit as applicable..." in accordance with sub-article 11.4 (b) of Section 0071.0 - General Conditions. The agreed unit prices including overhead and profit are as follows:

	<u>ITEM</u>	<u>UNIT PRICE</u>
1.	17 inch Augering	\$88/foot
2.	16 inch Pipe Grouted	\$55/foot
3.	Additional 55 Gal. Drums	\$33 each
4.	6 inch Pipe Grouted	\$44/foot
5.	Additional Decons	\$132/hour
6.	Material Handling-Drum	\$40 each

II. REASON FOR CHANGE:

Upon further review of the six wells included under this change order, it was determined by the Owner and Engineer that some additional measures should be taken in order to protect the integrity of these wells. Therefore the double-casing system was considered, as a solution to the potential problems with cross-contamination.

III. CHANGE IN CONTRACT PRICE

Original Contract Price: \$12,289,250.00

Contract Price after previous Change Order: N/A

Estimated Net Increase due to this Change Order: \$44,124.00 *

IV. CHANGE IN CONTRACT

CALENDAR DAYS

COMPLETION DATE

Original Contract Time 625

Contract Time after previous Change Order N/A

Estimated Net (INCREASE) due to this Change Order: \$44,124.00 *

New Contract Time including this Change Order 625

* See attached cost summary. The actual change in the contract amount will be determined by agreed unit prices and final quantities approved by engineer.

It is understood and agreed that, unless expressly stated above, the work herein authorized will not extend the time for the completion of the contract.

This work is to be performed in accordance with the terms of the contract and original plans and specifications, except as herein modified. It is understood and agreed that this order shall be deemed executory only to the extent of moneys available and no liability shall be incurred by the State beyond the moneys available for the purpose.

APPROVALS

Contractor (Print) _____

(Sign) _____

Title: _____

Date: _____

Engineer (Print) _____

(Sign) _____

Title: _____

YSDEC/Division of Hazardous Waste Remediation

(Print) _____

(Sign) _____

Title: _____

Date: _____

NEW YORK STATE DEPARTMENT OF ENVIRONMENTAL CONSERVATION

(Print) _____

(Sign) _____

Title: _____

Date: _____

For NYS Dept. of Audit and Control Approval

Date: _____

New York State Department of Environmental Conservation
Division of Hazardous Waste and Remediation

CHANGE ORDER

Date of Issue: June 29, 1989

Change Order No.:

Change Order Amount: \$41.00 DEDUCT

Contract No.: D-001939

Project Name: Black and Bergholtz Creek Remediation,
Love Canal, Niagara County

NYSDEC Project No.: Site Number 9-32-020

Contractor's Name: Severson Environmental Services, Inc.

I. DESCRIPTION OF CHANGE:

The work that is to be included in this change order shall include the following:

- 1A. Credit for allowing the Contractor to place perimeter fence posts without concrete footings as originally specified in the contract documents. [Bergholtz and Black Creek Area]
- 1B. Payment for an improvement to the pedestrian bridge hand rails that is to cross Bergholtz Creek at 93rd Street.
- 1C. Payment for changes in perimeter fence layout in two locations. [Bergholtz and Black Creek Area]
- 1D. The addition of two water stop strips on each manhole joint within the leachate collection and transfer system of the DCF.

The net result of this change order shall be in the form of a credit that will be due to the Owner.

DRAWINGS: 1D. GZA - Typical Manhole Joint Detail (May, 1989) Rev.

SPECIFICATION: All work performed under this change order shall be conducted in accordance with the contract specifications and as ordered by the Engineer.

PAYMENT: This payment, made to the Owner, shall be in the form of a deduction from the next monthly pay estimate upon execution of this change order.

II. REASON FOR CHANGE:

- 1A. The importance of having concrete footings for the perimeter fencing was determined to be unnecessary due to the fact that no "freeze-thaw" would be encountered during the term

of the fence being in place. This action reduced the time and cost for this operation. For this time and cost savings the Contractor has offered a credit that is equal to the amount of work that was eliminated.

- 1B. While in the final approval stage with the Pedestrian Bridge across Bergholtz Creek, the engineering department of the City of Niagara Falls took exception to the hand rail design and requested that a change in the design be initiated. This change resulted in some additional expenses by the bridge manufacturer which shall be covered under this change order.
- 1C. Due to a complaint of the owner of "Old Greenwalds" restaurant, the Owner ordered a change in the location of a section of perimeter fencing that would have interfered with the business in that area. The change in location that was ordered by the Owner came at a point in which work in that area that had already commenced. Because of that fact, some additional expenses were incurred by the sub-contractor performing the work in order to remove and reposition the fencing in question. In addition, a change in location was ordered by the Owner along the south bank of the creek where it passed through a Mr. Berrard's property. The extra cost of relocation in this area will also be included in this change order.
- 1D. The project specifications (Section 02606, paragraph 2.3) calls for rubber gaskets between each manhole riser section. To limit infiltration into the manholes or leakage from the manholes, the manhole joint should also include two 1-inch square bentonite-coated butyl rubber joint sealants between each manhole section.

III. CHANGE IN CONTRACT PRICE

Original Contract Price: \$12,289,250.00

Contract Price after previous Change Order:

Estimated Net DECREASE due to this Change Order: \$41.00(-)

Itemization:

1A. Credit for Fence Post Footings	\$4,500.00(-)
1B. Change in Pedestrian Bridge	
Hand Rails	242.00
1C. Perimeter Fence Layout	317.00
1D. Manhole Waterstop	<u>3,900.00</u>

Total: \$ 41.00(-)

<u>IV. CHANGE IN CONTRACT</u>	<u>CALENDAR DAYS</u>	<u>COMPLETION DATE</u>
Original Contract Time	625	
Contract Time after previous Change Order	N/A	
Estimated Net (DECREASE) due to this Change Order:	0	
New Contract Time including this Change Order	625	

It is understood and agreed that, unless expressly stated above, the work herein authorized will not extend the time for the completion of the contract.

This work is to be performed in accordance with the terms of the contract and original plans and specifications, except as herein modified. It is understood and agreed that this order shall be deemed executory only to the extent of moneys available and no liability shall be incurred by the State beyond the moneys available for the purpose.

APPROVALS

Contractor (Print) Severson Environmental Services, Inc.

(Sign) Title: Vice President

Date:

Engineer (Print) Tams Consultants, Inc.

(Sign) Title: Resident Engineer

NYSDEC/Division of Hazardous Waste Remediation

(Print)

(Sign) Title:

Date:

NEW YORK STATE DEPARTMENT OF ENVIRONMENTAL CONSERVATION

(Print) _____

(Sign) _____

Title: _____

Date: _____

For NYS Dept. of Audit and Control Approval

Date: _____

c:CHOR.JB

New York State Department of Environmental Conservation
Division of Hazardous Waste and Remediation

CHANGE ORDER

Date of Issue: June 30, 1989

Change Order No.: 7

Change Order Amount: \$2,751.00

Contract No.: D-001939

Project Name: Black and Bergholtz Creek Remediation,
Love Canal, Niagara County

NYSDEC Project No.: Site Number 9-32-020

Contractor's Name: Severson Environmental Services, Inc.

I. DESCRIPTION OF CHANGE

- 1A. Extension of 2" steel SCH. 80 vent pipe with accompanying pipe support channel MC6X 12 for proposed 10,000 gallon leachate storage tank. [DCF Construction Area]
- 1B. Abandonment and removal of unknown 8" diameter clay tile drainage pipe found during excavation of subgrade for lower leachate collection system of the DCF Cell construction. Work required was below elevation 570.5 feet, therefore Hazardous Level 'C'. Work consisted of dewatering, grouting of tile and removal of catch basin. [DCF Construction Area]

DRAWINGS

- 1A. Reference Contract Drawing No. 223 and TAMS Revision Sketch Dated 3/22/89.
- 1B. Not applicable.

SPECIFICATION

All work performed under this change order shall be conducted in accordance with the contract specifications and as ordered by the Engineer.

PAYMENT

- 1A. By acceptance of agreed lump sum price based on estimated cost plus overhead and profit as applicable in accordance with Sub-Article 11.4(b) of Section 0071.0 - General Conditions.

1B. Actual cost of labor and materials plus overhead and profit, cost determined as the work progressed in accordance with Sub-Article 11.4(d) of Section 0071.0 - General Conditions.

II. REASON FOR CHANGE:

- 1A. The modification of the tank vent will allow a back-up of leachate in the system without any risk of over topping during construction filling of the DCF.
- 1B. The abandonment of the 6" drain was performed to prevent any potential for migration of leachate from the site.

III. CHANGE IN CONTRACT PRICE

Original Contract Price: \$12,289,250.00
Contract Price after previous Change Order: N/A
Net Increase due to this Change Order: \$2,751.00

Itemization:

1A.	10,000 Gallon Tank Vent	\$1,094.00
1B.	Utility Abandonment	<u>\$1,657.00</u>
	Total:	\$2,751.00

IV. CHANGE IN CONTRACT CALENDAR DAYS COMPLETION DATE

Original Contract Time	625
Contract Time after previous Change Order	N/A
Net (INCREASE) due to this Change Order:	0
New Contract Time including this Change Order	625

It is understood and agreed that, unless expressly stated above, the work herein authorized will not extend the time for the completion of the contract.

This work is to be performed in accordance with the terms of the contract and original plans and specifications, except as herein modified. It is understood and agreed that this order shall be deemed executory only to the extent of moneys available and no liability shall be incurred by the State beyond the moneys available for the purpose.

APPROVALS

Contractor (Print) Sevenson Environmental Services, Inc.

(Sign) _____ Title: Vice President

Date: _____

Engineer (Print) TAMS Consultants, Inc.

(Sign) _____ Title: Resident Engineer

Date: _____

NYSDEC/Division of Hazardous Waste Remediation

(Print) _____

(Sign) _____ Title: Acting Division Director

Date: _____

NEW YORK STATE DEPARTMENT OF ENVIRONMENTAL CONSERVATION

(Print) _____

(Sign) _____ Title: Director, Div. of Fiscal Mgmt.

Date: _____

For NYS Dept. of Audit and Control Approval

Date: _____

New York State Department of Environmental Conservation
Division of Hazardous Waste and Remediation

CHANGE ORDER

Date of Issue: July 19, 1989

Change Order No.:

Change Order Amount: \$22,158.00

Contract No.: D-001939

Project Name: Black and Bergholtz Creek Remediation,
Love Canal, Niagara County

NYSDEC Project No.: Site Number 9-32-020

Contractor's Name: Severson Environmental Services, Inc.

I. DESCRIPTION OF CHANGE

Reconstruction of Reach B Temporary Haul Road from west edge of 93rd Street School paved parking lot to the west post of the North Access Ramp Gate to Reach 'A' (approximately 380 linear feet). See attached location sketch. Road section shall be the same as approved submittal for 'Access Road Within the Remediation Zone Design'. The existing haul road surface shall be regraded and proof rolled prior to new haul road construction.

DRAWINGS

1. Location Sketch [Exhibit 1].
2. Schematic Roadway Cross Section (Glynn 3/31/89) & Design Summary Sheet [Exhibit 2]

SPECIFICATION

All work performed under this change order shall be conducted in accordance with the contract specifications, attached exhibits and as ordered by the Engineer.

PAYMENT

Payment will be made in a lump sum upon completion and approval of all work in this change order.

II. REASON FOR CHANGE:

Instability of existing subgrade and necessary NYSDEC requirement to leave material in-situ due to possibility of low level contamination resulted in failure of standard haul road construction on topsoil.

III. CHANGE IN CONTRACT PRICE

Original Contract Price: \$12,289,250.00

Contract Price after previous Change Order:

Net Increase due to this Change Order: \$22,158.00

IV. CHANGE IN CONTRACT CALENDAR DAYS COMPLETION DATE

Original Contract Time 625

Contract Time after
previous Change Order N/A

Net (INCREASE)
due to this Change Order: To be determined

New Contract Time including
this Change Order 625

It is understood and agreed that, unless expressly stated above, the work herein authorized will not extend the time for the completion of the contract.

This work is to be performed in accordance with the terms of the contract and original plans and specifications, except as herein modified. It is understood and agreed that this order shall be deemed executory only to the extent of moneys available and no liability shall be incurred by the State beyond the moneys available for the purpose.

APPROVALS

Contractor (Print) Sevenson Environmental Services, Inc.

Sign) Title: Vice President

Date: _____

Engineer (Print) TAMS Consultants, Inc.

(Sign) Title: Resident Engineer

Date:

NYSDEC/Division of Hazardous Waste Remediation

(Print)

(Sign) Title: Acting Division Director

Date:

NEW YORK STATE DEPARTMENT OF ENVIRONMENTAL CONSERVATION

(Print)

(Sign) Title: Director, Div. of Fiscal Mgmt.

Date:

For NYS Dept. of Audit and Control Approval

Date:

c:chord719

New York State Department of Environmental Conservation
Division of Hazardous Waste and Remediation

Date of Issue: July 26, 1989

Change Order No.:

Estimated Change Order Amount:

Contract No.: D-001939

Project Name: Black and Bergholtz Creek Remediation,
Love Canal, Niagara County

NYSDEC Project No.: Site Number 9-32-020

Contractor's Name: Severson Environmental Services, Inc.

I. DESCRIPTION OF CHANGE

The owner instructed the contractor to suspend all telescoping well construction activities pending implementation of a change in procedure. The effective date of the change order was May 22, 1989. The order to proceed was issued on June 13, 1989, 17 working days later.

DRAWINGS: N/A

SPECIFICATION

All work to be completed under this change order shall conform to the contract specifications and/or as ordered by the Engineer/Owner.

MEASUREMENT

The unit of measurement shall be as follows for the various items:

<u>ITEM</u>	<u>UNIT</u>
Drill-rig standby cost	per hour

PAYMENT

Payment for the units measured as provided previously were made on the basis of "...acceptance of agreed unit prices based on estimated cost plus overhead and profit as appli-

cable..." in accordance with sub-article 11.4 (b) of Section 0071.0 - General Conditions. The agreed unit prices including overhead and profit were as follows:

<u>ITEM</u>	=	<u>UNIT PRICE</u>
drill-rig standby cost	=	\$150/hr.
total cost based on an 8 hr. day for 17 working days	=	\$20,400.00
+ 10% (profit & overhead)	=	<u>2,040.00</u>
Total		\$22,440.00

II. REASON FOR CHANGE:

The owner ordered the change in procedure for the installation of the telescoping wells due to contamination problems encountered during the installation of the wells.

III. CHANGE IN CONTRACT PRICE

Original Contract Price: \$12,289,250.00

Contract Price after previous Change Order: N/A

Estimated Net Increase due to this Change Order: \$22,440.00

IV. CHANGE IN CONTRACT CALENDAR DAYS COMPLETION DATE

Original Contract Time 625

Contract Time after
previous Change Order N/A

Estimated Net (INCREASE)
due to this Change Order: 0

New Contract Time including
this Change Order 625

It is understood and agreed that, unless expressly stated above, the work herein authorized will not extend the time for the completion of the contract.

This work is to be performed in accordance with the terms of the contract and original plans and specifications, except as herein modified. It is understood and agreed that this order shall be deemed executory only to the extent of moneys available and no liability shall be incurred by the State beyond the moneys available for the purpose.

APPROVALS

Contractor (Print) Sevenson Environmental Services, Inc.

(Sign) _____ Title: _____

Date: _____

Engineer (Print) TAMS Consultants, Inc.

(Sign) _____ Title: Resident Engineer

Date: _____

NYSDEC/Division of Hazardous Waste Remediation

(Print) _____

(Sign) _____ Title: _____

Date: _____

NEW YORK STATE DEPARTMENT OF ENVIRONMENTAL CONSERVATION

(Print) _____

(Sign) _____ Title: _____

Date: _____

For NYS Dept. of Audit and Control Approval

Date: _____

New York State Department of Environmental Conservation
Division of Hazardous Waste and Remediation

CHANGE ORDER

Date of Issue: August 12, 1989

Change Order No.: 8

Change Order Amount: \$26,145.00

Contract No.: D-001939

Project Name: Black and Bergholtz Creek Remediation,
Love Canal, Niagara County

NYSDEC Project No.: Site Number 9-32-020

Contractor's Name: Severson Environmental Services, Inc.

I. DESCRIPTION OF CHANGE

The work included in this change order consists of the following described items and any additional work as required by engineer:

- 1A. Revised location of DDSF Building by increasing building setback 10 feet_± from Read Avenue. This resulted in an additional 10 foot length of driveway section and increased the quantities for clearing & grubbing and general excavation items at the north end of site.
- 1B. Modify existing catch basin, relocate existing manhole, install new catch basin, relocate driveway entrance, reversed slope of 30 feet parking area apron and change site grading for existing Love Canal swale.
- 1C. Perform additional dewatering for basement excavation and backfill in DDSF building foundation area.

DRAWINGS

- 1A. Revised Contract Drawing No. 117 (5/2/89)
- 1B. Revised Contract Drawing No. 117 (5/2/89)
- 1C. N/A

SPECIFICATION

All work performed under this change order shall be conducted in accordance with the contract specifications and as ordered by the Engineer.

PAYMENT

Payment for the work as described above will be made on the basis of "estimate of actual cost of labor and materials plus overhead and profit, cost to be determined as the work progresses . . ." in accordance with Sub-article 11.4(c) of Section 071.0 - General Conditions.

II. REASON FOR CHANGE:

- 1A. Proposed DDSF Building foundation location conflicted with existing 15" PVC storm sewer lateral at Station 1-10₊.
- 1B. Existing catch basin at Station 2+46 conflicted with proposed DDSF pavement and trench drain. It was also necessary to reverse pavement slope on east side of building and move driveway entrance to avoid subgrade interference with existing Love Canal HDPE liner cap.
- 1C. Unknown source of storm water was recharging basement #920 during excavation/backfill operations.

III. CHANGE IN CONTRACT PRICE

Original Contract Price: \$12,289,250.00

Contract Price after previous Change Order: N/A

*Net Increase due to this Change Order: \$26,145.00

*Preliminary Estimate [See Payment Method]

IV. CHANGE IN CONTRACT

CALENDAR DAYS

COMPLETION DATE

Original Contract Time 625

Contract Time after previous Change Order N/A

Net (INCREASE) due to this Change Order: \$26,145.00

New Contract Time including this Change Order 625

It is understood and agreed that, unless expressly stated above, the work herein authorized will not extend the time for the completion of the contract.

This work is to be performed in accordance with the terms of the contract and original plans and specifications, except as herein modified. It is understood and agreed that this order shall be deemed executory only to the extent of moneys available and no liability shall be incurred by the State beyond the moneys available for the purpose.

APPROVALS

Contractor (Print) Sevenson Environmental Services, Inc.

(Sign) _____ Title: Vice President

Date: _____

Engineer (Print) TAMS Consultants, Inc.

(Sign) _____ Title: Resident Engineer

Date: _____

NYSDEC/Division of Hazardous Waste Remediation

(Print) _____

(Sign) _____ Title: Acting Division Director

Date: _____

NEW YORK STATE DEPARTMENT OF ENVIRONMENTAL CONSERVATION

(Print) _____

(Sign) _____ Title: Director, Div. of Fiscal Mgmt.

Date: _____

For NYS Dept. of Audit and Control Approval

Date: _____

c:chord711

New York State Department of Environmental Conservation
Division of Hazardous Waste and Remediation

CHANGE ORDER

Date of Issue: August 14, 1989

Change Order No.:

Change Order Amount:

Contract No.: D-001939

Project Name: Black and Bergholtz Creek Remediation,
Love Canal, Niagara County

NYSDEC Project No.: Site Number 9-32-020

Contractor's Name: Severson Environmental Services, Inc.

I. DESCRIPTION OF CHANGE

Construct clay reinforcement for primary sheet pile cofferdam at the confluence of Cayuga and Bergholtz Creeks. Work to include temporary sandbag placement at sheeting, dewatering, temporary upstream cofferdam construction, creek excavation and clay placement. Majority of work would be within remediation zone and, therefore require Level 'C' protection. The performance of this work will be under the observation of the owner and the engineer.

DRAWINGS

N/A

SPECIFICATION

All work completed under this change order shall conform to the contract specifications and as ordered by the engineer.

PAYMENT

Payment for the work as described above will be made on the basis of "estimate of actual cost of labor and materials plus overhead and profit, cost to be determined as the work progresses . . ." in accordance with Sub-article 11.4(c) of Section 071.0 - General Conditions.

II. REASON FOR CHANGE:

The sheet piles were not able to be driven to the minimum design depth of 12.5 feet, (Elevation of 550 feet) due to rock interference at a depth of 556 feet ±.

III. CHANGE IN CONTRACT PRICE

Original Contract Price: \$12,289,250.00

Contract Price after previous Change Order:

*Net Increase due to this Change Order: \$25,000.00

*Preliminary Estimate [See Payment Method]

IV. CHANGE IN CONTRACT CALENDAR DAYS COMPLETION DATE

Original Contract Time 625

Contract Time after
previous Change Order N/A

Net (INCREASE)
due to this Change Order: To be determined

New Contract Time including
this Change Order 625

This work is to be performed in accordance with the terms of the contract and original plans and specifications, except as herein modified. It is understood and agreed that this order shall be deemed executory only to the extent of moneys available and no liability shall be incurred by the State beyond the moneys available for the purpose.

APPROVALS

Contractor (Print) Sevenson Environmental Services, Inc.

(Sign) _____ Title: Vice President

Date: _____

Engineer (Print) TAMS Consultants, Inc.

(Sign) _____ Title: Resident Engineer

Date: _____

NYSDEC/Division of Hazardous Waste Remediation

(Print)

(Sign)

Title: Acting Division Director

Date:

NEW YORK STATE DEPARTMENT OF ENVIRONMENTAL CONSERVATION

(Print)

(Sign)

Title: Director, Div. of Fiscal Mgmt.

Date:

For NYS Dept. of Audit and Control Approval

Date:

c:chord720

New York State Department of Environmental Conservation
Division of Hazardous Waste and Remediation

CHANGE ORDER

Date of Issue: August 14, 1989

Change Order No.:

Change Order Amount:

Contract No.: D-001939

Project Name: Black and Bergholtz Creek Remediation,
Love Canal, Niagara County

NYSDEC Project No.: Site Number 9-32-020

Contractor's Name: Severson Environmental Services, Inc.

I. DESCRIPTION OF CHANGE

All required underground utility abandonment, removal and dewatering at the intersection of 97th Street and Wheatfield Street [DCF area of project] necessary to allow the installation of DCF force main from Manhole 8 to NYSDEC Leachate Treatment Facility. The performance of this work will be under the observation of the owner and the engineer. Dewatering method will be as per NYSDEC direction.

DRAWINGS

N/A

SPECIFICATION

All work completed under this change order shall conform to the contract specifications and as ordered by the engineer.

PAYMENT

Payment for the work as described above will be made on the basis of "estimate of actual cost of labor and materials plus overhead and profit, cost to be determined as the work progresses . . ." in accordance with Sub-article 11.4(c) of Section 071.0 - General Conditions.

II. REASON FOR CHANGE:

Unknown utilities found during excavation for DCF force main trench.

III. CHANGE IN CONTRACT PRICE

Original Contract Price: \$12,289,250.00

Contract Price after previous Change Order:

*Net Increase due to this Change Order: \$15,000.00

*Preliminary estimate [See Payment Method]

IV. CHANGE IN CONTRACT CALENDAR DAYS COMPLETION DATE

Original Contract Time 625

Contract Time after
previous Change Order N/A

Net (INCREASE)
due to this Change Order: To be determined

New Contract Time including
this Change Order 625

This work is to be performed in accordance with the terms of the contract and original plans and specifications, except as herein modified. It is understood and agreed that this order shall be deemed executory only to the extent of moneys available and no liability shall be incurred by the State beyond the moneys available for the purpose.

APPROVALS

Contractor (Print) Sevenson Environmental Services, Inc.

(Sign) Title: Vice President

Date: _____

Engineer (Print) TAMS Consultants, Inc.

(Sign) Title: Resident Engineer

Date: _____

NYSDEC/Division of Hazardous Waste Remediation

(Print) _____

(Sign) _____ Title: Acting Division Director

Date: _____

NEW YORK STATE DEPARTMENT OF ENVIRONMENTAL CONSERVATION

(Print) _____

(Sign) _____ Title: Director, Div. of Fiscal Mgmt.

Date: _____

For NYS Dept. of Audit and Control Approval

Date: _____

c:chord809

New York State Department of Environmental Conservation
Division of Hazardous Waste and Remediation

CHANGE ORDER

Date of Issue: September 16, 1989

Change Order No.:

Change Order Amount:

Contract No.: D-001939

Project Name: Black and Bergholtz Creek Remediation,
Love Canal, Niagara County

NYSDEC Project No.: Site Number 9-32-020

Contractor's Name: Severson Environmental Services, Inc.

I. DESCRIPTION OF CHANGE

Remediation of last 80 feet (+) of Reach 'C' (Bergholtz Creek) between primary sheet pile cofferdam (station 36+33) and secondary clay cofferdam (station 35+50). Work consists of:

1. Excavation of 10' wide strip underwater to a depth of 18" adjacent to both the steel sheetpile cofferdam and riprap section of the Cayuga Road Bridge abutment.
2. Installation of impervious membrane and placement of clay liner for same locations in order to seal the riprap and strengthen the existing sheetpile cofferdam.
3. Dewatering of Area.
4. Removal of secondary clay cofferdam and excavation of dewatered area to a depth of 18 inches.
5. Backfill area with Type I gravel. (Original contract work item)
6. Flood Reach 'C'. (Original contract work item)
7. Excavate remaining clay and replace with Type I gravel.

Majority of work would be within the Remediation Zone and therefore require Level 'C' protection. The performance of this work will be under the observation of the Owner and the Engineer.

DRAWINGS

N/A

SPECIFICATION

All work completed under this change order shall conform to the contract specifications and as ordered by the engineer.

PAYMENT

Payment for the work as described above will be made on the basis of "estimate of actual cost of labor and materials plus overhead and profit, cost to be determined as the work progresses . . ." in accordance with Sub-article 11.4(c) of Section 071.0 - General Conditions.

II. REASON FOR CHANGE:

Location of sheetpile north closure at bridge abutment riprap prevented the proper dewatering of Reach 'C'. There was excessive seepage of water through the riprap from the Cayuga Creek portion of stream confluence at bridge location.

III. CHANGE IN CONTRACT PRICE

Original Contract Price: \$12,289,250.00

Contract Price after previous Change Order: N/A

*Net Increase due to this Change Order: \$20,088.00

*Preliminary Estimate [See Payment Method]

IV. CHANGE IN CONTRACT

CALENDAR DAYS

COMPLETION DATE

Original Contract Time

625

Contract Time after
previous Change Order

N/A

Net (INCREASE)

due to this Change Order:

To be determined.

New Contract Time including
this Change Order

625

It is understood and agreed that, unless expressly so stated above, the work herein authorized will not extend the time for the completion of the contract.

This work is to be performed in accordance with the terms of the contract and original plans and specifications, except as herein modified. It is understood and agreed that this order shall be deemed executory only to the extent of moneys available and no liability shall be incurred by the State beyond the moneys available for the purpose.

APPROVALS

Contractor (Print) Sevenson Environmental Services, Inc.

(Sign) _____ Title: Vice President

Date: _____

Engineer (Print) TAMS Consultants, Inc.

(Sign) _____ Title: Resident Engineer

Date: _____

NYSDEC/Division of Hazardous Waste Remediation

(Print) _____

(Sign) _____ Title: Acting Division Director

Date: _____

NEW YORK STATE DEPARTMENT OF ENVIRONMENTAL CONSERVATION

(Print) _____

(Sign) _____ Title: Director, Div. of Fiscal Mgmt.

Date: _____

For NYS Dept. of Audit and Control Approval

Date: _____

TAMS

LIST OF CONTRACT CLAIMS

New York State Department of Environmental Conservation
Black & Bergholtz Creeks Remediation
Sevenson Environmental Services, Inc.
Contract No. D-001939 Site N. 9-32-020

<u>DESCRIPTION</u>	<u>DATE</u>	<u>AMOUNT</u>	<u>ACTION</u>
Max SDR17 Material Spec	July-1-88	No Value	Denied (9/15/88)
Asphalt Testing Allowance	Aug-26-88	4,000.00	Denied (3/06/89)
DCF Area Dewatering	Sept-30-88	No Value	Denied (9/15/89)
91st Street Stop Signs	May-30-89	405.00	Awarded (2/23/90)
Cayuga Creek Turbidity	May-31-90	No Value	Denied (5/16/90)
40 Mil Liner Repair	July-13-89	1,110.66	Denied (2/16/90)
Meteorological Station	Oct-16-89	1,464.00	Awarded (2/23/90)
DDSF Wall Panels	Oct-25-89	4,450.77	Denied (6/08/90)
DDSF Door Jambs	Nov-15-89	3,885.65	Denied (6/07/90)
Crib Wall Disposal	Nov-28-89	6,357.00	Awarded (5/21/90)
Container Rental	Nov-30-89	63,171.37	Denied (7/18/90)
Pump Chamber 3A Cleaning	Feb-20-90	2,800.00	Awarded (7/10/90) \$1,793.00

D. Melancon

New York State Department of Environmental Conservation
50 Wolf Road, Albany, New York 12233



Thomas C. Jorling
Commissioner

Mr. Kim Lickfield
Project Manager
Sevenson Environmental Services, Inc.
2749 Lockport Road
Niagara Falls, NY 14302

FILE COPY
RECEIVED
JUL 16 1990
TAMS CONSULTANT, INC.

Re: Black and Bergholtz Creeks Remediation, Love Canal, Niagara County
Site No. 9-32-020, Contract No. D001939

Dear Mr. Lickfield:

Sevenson Environmental Services, Inc.'s (SES) February 20, 1990 letter addressed to Commissioner Thomas C. Jorling of the New York State Department of Environmental Conservation (NYSDEC) has been reviewed. This letter sets forth an appeal under Article 16 of the General Conditions entitled "Disputes", of the above referenced contract. The appeal is concerned with the deduction of Love Canal Pump Chamber 3A cleaning costs from SES's payment no. 21. The NYSDEC considers SES's February 20, 1990 letter and its enclosures and also SES's letter to Robert Schick, Chief, Remedial Section A, dated May 2, 1990 as SES's opportunity to be heard, and as such it presents all evidence in support of this appeal.

SES in its appeal, contends that no deduction to payment no. 21 should have been made due to the following facts:

1. The work being performed at PC 3A was under Change Order no. 12 in which SES had provided prefiltering and clarification of groundwater that was being pumped to PC 3A. This "pretreatment" of the collected water prior to discharging to PC 3A was required before the NYSDEC would authorize discharge directly to PC 3A. SES feels that the dewatering operations complied with the approved procedures for discharging into PC 3A.
2. The NYSDEC never afforded SES the opportunity to clean PC 3A but instead hired Wizard Methods to perform the work. If SES had been notified this cleaning was required, it would have been performed under Change Order no. 12 work. Additionally, SES claims their costs would have been significantly less because SES owns their own vac truck.

The NYSDEC has considered the arguments put forth by SES, the provisions of the contract and the interpretations thereof. In evaluating the appeal, the following facts have been taken into consideration:

1. The material found in the bottom of PC 3A included, concrete, wood and duct tape. These materials were left over from SES's work installing the discharge piping for the force main through the wall of PC 3A, not the dewatering operations at 97th Street and Wheatfield.
2. Prior to the NYSDEC's approval of SES discharging their dewatering operations under C.O. no. 12 into PC 3A, the NYSDEC discussed the

importance of the operation of this pump station with SES and the need to keep it operational at all times. SES was informed that if pump station 3A was to fail it would have immediate impacts on the processing of leachate and therefore the NYSDEC could not tolerate any "down time" at this pump station.

3. Due to the impending possibility of a tremendous amount of process water from the DCF, as well as NYSDEC's obligation to properly operate the collection system and maintain the containment system, it was necessary to immediately rectify the situation. In this case, total failure of PC 3A pumps due to impeller blockage by foreign material, the NYSDEC could not afford any delays which would have resulted if discussions were held between SES and the NYSDEC concerning responsibility for the situation. It was essential to return the pump station back to normal operation as fast as possible in order to process the collected leachate from the field. Because the NYSDEC had just completed awarding a contract regarding Carbon Removal and Pump Chamber Cleaning, the subcontractor under this contract, Wizard Methods, was contacted to respond as soon as possible.

Having given due consideration to the position as stated by SES, and in consideration of the factors presented above, the NYSDEC has made a determination as follows:

1. SES had the right to respond to the situation and be given the opportunity to clean PC 3A. Based on SES's cost estimate submitted by SES on May 2, 1990, SES's cost to clean PC 3A, including Equipment, Labor and Materials would have been \$456.72. These costs would not have been allowed under change order no. 12 work, therefore SES would have had to absorb the cost of the cleaning under the Black and Bergholtz Creeks Remediation Contract No. D001939. This cost represents what SES would have incurred if they had performed the cleaning of PC 3A.
2. The NYSDEC incurred costs due to the pump failures in January 1990 due to impeller obstructions from foreign material caused by SES's work at PC 3A. Costs included labor and materials for the installation and maintenance of temporary utility pumps and hoses to allow for the discharge of collected leachate from PC 3A to the Treatment Plant for processing. NYSDEC's estimated costs for four (4) days of operation to dewater the manhole for cleaning is \$550.00.
3. Assuming that SES could have performed the cleaning at a cost less than the \$2,800.00 charged by Wizard Methods and that the cleaning would have been performed in the same time frame as was performed by Wizard Methods, SES should only be assessed those costs which they would have incurred for the actual cleaning and costs incurred by the NYSDEC for the temporary pumping of PC 3A to dewater the site. The remaining amount left over after this assessment should be reimbursed to SES.

Based on the above determination, the amount to be reimbursed to SES is calculated as follows:

Amount the NYSDEC paid Wizard to clean PC 3A	\$2,800.00
Estimated cost for SES to clean PC 3A	- 456.72
Estimated cost for NYSDEC to temporarily pump PC 3A	- <u>550.00</u>
Amount to be reimbursed SES	\$1,793.28

Therefore, the NYSDEC agrees to reimburse SES the amount of \$1,793.28. This amount will be added to the final contract cost. The amount of \$1,006.72 remains withheld to offset the cost SES would have and the NYSDEC did incur to clean out PC 3A.

If there are any questions, please contact Mr. Robert W. Schick, P.E. or Philip G. Waite, P.E. of my staff, at (518) 457-4343.

Sincerely,

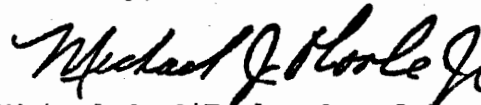

Michael J. O'Toole, Jr., P.E.
Director
Division of Hazardous Waste Remediation

cc: R. Elia
J. Fiteni
D. Melancon

ORIGINAL

D.M

New York State Department of Environmental Conservation
50 Wolf Road, Albany, New York 12233



Thomas C. Jorling
Commissioner

Mr. Kim Lickfield
Project Manager
Sevenson Environmental Services, Inc.
2749 Lockport Road
Niagara Falls, NY 14302

FILE COPY

RECEIVED

JUL 23 1990

TAMS CONSULTANT, INC.

Re: Black and Bergholtz Creeks Remediation, Love Canal, Niagara County
Site No. 9-32-020, Contract No. D001939

Dear Mr. Lickfield:

Sevenson Environmental Services, Inc.'s (SES) February 20, 1990 letter addressed to Commissioner Thomas C. Jorling of the New York State Department of Environmental Conservation (NYSDEC) has been reviewed. This letter sets forth an appeal under Article 16 of the General Conditions entitled "Disputes", of the above referenced contract. The appeal is concerned with the decision of TAMS Consultants, Inc. regarding container rental costs for the month of August 1989 for the 30 yard containers SES rented from Bear Equipment. The NYSDEC considers SES's February 20, 1990 letter and its enclosures as SES's opportunity to be heard, and as such it presents all evidence in support of this appeal.

SES in its appeal, presents the following three rebuttals to TAMS's February 15, 1990 letter disallowing a change order for the rental costs:

1. According to SES, they were ready to begin filling the Dewatering Containment Facility (DCF) with construction demolition debris (CDD) material on August 1, 1989. They argue that if the NYSDEC had allowed the placement of CDD material into the DCF to commence on that date SES would not have had to pay container rental costs for the month of August. Also, SES claims that since TAMS neither approved or disapproved SES's revised construction schedule submitted on February 14, 1989 and revised on April 3, 1989, that both the NYSDEC and TAMS should have been aware that SES planned to fill the DCF beginning on August 1, 1989.
2. SES claims that all sea boxes have been sold and the fact that there are remaining boxes still at the site is not SES's fault but instead the fault of the new owners who have not yet arranged for pick up. SES also indicates that the 30 yard containers were emptied first to expedite their return to Bear Equipment. It was the NYSDEC's delay in allowing SES to commence filling the DCF that resulted in SES incurring additional rental costs for the month of August.
3. Finally SES claims that since they were denied use of the containers for the month of August due to the NYSDEC revising the DCF construction, the fact that a time extension of four days was granted to SES does not apply and rental costs for the entire month are justified.

The NYSDEC has considered the arguments put forth by SES and the responses by TAMS and the provisions of the contract and the interpretations thereof. In evaluating the appeal, the following facts have been taken into consideration:

1. The NYSDEC and TAMS reviewed SES's revised schedule dated April 3, 1989. The comments that were submitted to SES based on that review were never formally addressed and resubmitted by SES for additional consideration. Because of that, an approved construction schedule showing when the DCF was to be filled with material was never adopted.
2. Although SES submitted a letter to TAMS on July 13, 1989 indicating the DCF was nearing completion and requesting notification of any outstanding items needing completion prior to approval, SES did not submit notice of their claim that the DCF was substantially complete until July 31, 1989.
3. On August 1, 1989, the DCF was not 100% completed and ready to accept CDD material. Based on an inspection performed on August 9, 1989, it was determined that additional work was necessary by SES prior to allowing CDD material to be placed.
4. A punch list of deficiencies was submitted to SES on August 9, 1989 and although some of the punch list items referred to the revised DCF construction, the remainder applied to the original DCF design. These items included: regrading the access ramp, sealing the holding tank liner, testing the leachate collection lines and the completion of the force main from the holding tank. These items were identified and agreed to in March 1989 as being necessary to declare the DCF substantially complete. SES did not satisfactorily complete work on the punch list items until August 23, 1989, 14 calendar days after the punch list was submitted to SES. Therefore, SES would have still required the use of the containers for this amount of time while the punch list items were being corrected.
5. With OCC's involvement in the remediation contract, several work tasks required under the contract to be completed by SES were eliminated. These items included: completion of the CDD cell of the DCF, filling the DCF with on-site hazardous waste drums and the need to import "suitable material" for the completion/capping of the DCF. The elimination of these tasks allowed SES to substantially complete the contract by the contractual completion date. At the time the temporary stop work order was issued for the CDD cell (June 30, 1989) the construction of the CDD cell was lagging behind the construction of the DCF cell. At that time SES's intent was to dedicate the majority of their effort to complete the DCF cell to prepare for the possibility of having to place creek sediments into it. A minimal effort was being given to the CDD cell. The placement of the CDD material stored in the containers was to be considered later once the sediment excavation task was commencing properly. If OCC had not become involved, the requirement to complete, fill and cap the CDD cell would have extended the time SES needed to use the CDD containers past August and payment for August's rental costs would have still been necessary.

Taking the above facts into consideration, the NYSDEC feels that SES was not ready to fill the DCF until August 23, 1989 and the cost for the additional container rentals for the month of August is not justified. Therefore the

NYSDEC denies SES's claim that they are entitled to the container rental costs and associated equipment rental costs for the month of August.

If there are any questions, please contact Mr. Robert W. Schick, P.E. or Philip G. Waite, P.E. of my staff, at (518) 457-4343.

Sincerely,

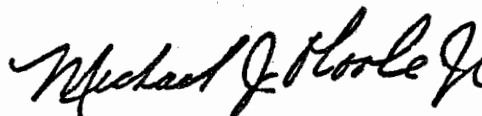

Michael J. O'Toole, Jr., P.E.
Director
Division of Hazardous Waste Remediation

cc: R. Elia
J. Fiteni
D. Melancon

FILE COPY

New York State Department of Environmental Conservation
50 Wolf Road, Albany, New York 12233-1010

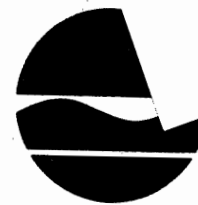

Thomas C. Jorling
Commissioner

RECEIVED

MAY 21 1990
MAY 23 1990

Mr. Kim Lickfield
Project Manager
Sevenson Environmental Services, Inc.
2749 Lockport Road
Niagara Falls, NY 14302

TAMS CONSULTANT, INC.

Re: Black and Bergholtz Creeks Remediation, Love Canal, Niagara County
Site No. 9-32-020, Contract No. D001939

Dear Mr. Lickfield:

Sevenson Environmental Services, Inc.'s (SES) November 28, 1989 letter addressed to Commissioner Thomas C. Jorling of the New York State Department of Environmental Conservation (NYSDEC) has been reviewed. This letter sets forth an appeal under Article 16 of the General Conditions entitled "Disputes", of the above referenced contract. The appeal is concerned with the decision of Messrs. James Tuk, NYSDEC Construction Inspector, and Philip Waite, NYSDEC Project Engineer, regarding the disposal of the 91st Street crib wall material. The NYSDEC considers SES's November 28, 1989 letter and its enclosures as SES's opportunity to be heard, and as such it presents all evidence in support of this appeal.

SES in its appeal, contends that their interpretation of the specifications (Section 1800-19, paragraph 53.2, payment description for Item II-17) is correct in assuming that the material removed from the existing retaining wall should have been placed in the DCF, if the DCF had not been capped at the time the material was removed. SES continues by indicating that because of a delay in processing a change order involving the construction of the new crib wall at this location, capping of the DCF by SES proceeded prior to the removal of the existing retaining wall in order not to delay the completion of the overall project. Therefore SES claims that the NYSDEC is responsible for a changed condition, the need to have the material disposed of off-site, and should reimburse SES for the costs incurred.

The NYSDEC has considered the arguments put forth by SES and the responses by Messrs. Tuk and Waite and the provisions of the contract and the interpretations thereof. In evaluating the appeal, the following facts have been taken into consideration:

1. Section 1800-19, paragraph 53.2 does require disposal of the crib wall material in the DCF.
2. Even though the disposal was not possible, due to circumstances not caused by SES, there is no requirement in the contract specifications that the crib wall material, if not contaminated, be treated as non-contaminated when disposed of in an alternative manner.

3. Since the crib wall material is not specifically mentioned in Section II, 02903, paragraph 4.5.1 as it is in Section 1800-19, paragraph 53.2, the latter specification applies.

Taking the above facts into consideration, the NYSDEC hereby concludes that SES is entitled to the \$6,357.00 cost of disposing the material at the Modern Disposal Facility. This cost will be included in the final adjustment of the contract cost.

If there are any questions, please contact Mr. Robert W. Schick, P.E. or Philip G. Waite, P.E. of my staff, at (518) 457-4343.

Sincerely,



Michael J. O'Toole, Jr., P.E.
Director
Division of Hazardous Waste Remediation

cc: R. Elia
J. Fiteni
D. Melancon

W. Melanson

New York State Department of Environmental Conservation
50 Wolf Road, Albany, New York 12233



Thomas C. Jorling
Commissioner

JUN -7 1990

FILE COPY

Mr. Kim Lickfield
Project Manager
Sevenson Environmental Services, Inc.
2749 Lockport Road
Niagara Falls, NY 14302

Re: Black and Bergholtz Creeks Remediation, Love Canal, Niagara County,
Site No. 9-32-020, Contract No. D001939

Dear Mr. Lickfield:

Sevenson Environmental Services, Inc.'s (SES) November 15, 1989 letter addressed to Commissioner Thomas C. Jorling of the New York State Department of Environmental Conservation (NYSDEC) has been reviewed. This letter sets forth an appeal under Article 16 of the General Conditions entitled "Disputes", of the above referenced contract. The appeal is concerned with the decision rendered by TAMS Consultants, Inc. (TAMS) regarding structural requirements of the door jamb members of the Decontamination/Drum Storage Facility (DDSF). The NYSDEC considers SES's November 15, 1989 letter and its enclosures as SES's opportunity to be heard, and as such it presents all evidence in support of this appeal.

SES contends in its appeal that due to the need to modify the structural columns and header adjacent to each roll-up door in the DDSF, identified by TAMS during their structural review, SES's subcontractor for the erection of the facility, Innovative Building Systems Erection, incurred additional costs which were passed along to SES. SES claims that since TAMS required structural stiffener plates be attached to the main load bearing members surrounding each door, the building supplier, Strand Buildings, changed the section of the door jamb member from the type Innovative had assumed was to be installed when they bid on the subcontract. As a result, during the attachment of the building's exterior wall sheeting, the different section surrounding each door required pre-drilling in order to attach the sheeting to the door jamb section. Innovative, claiming that they did not anticipate the extra work to pre-drill the door jamb section and that the cost for this extra work was not reflected in their bid to SES, requested additional compensation to install the building as approved by TAMS.

The NYSDEC has considered the arguments put forth by SES, their subcontractor Innovative, the responses by TAMS and the provisions of the contract and the interpretations thereof. In evaluating the appeal, the following facts have been taken into consideration:

1. The design of each of the framed openings created by these doors was required to conform to the contract specifications including section 13125, paragraph 4.2, entitled "Framing and Structural Members". In that paragraph there is the following requirement, ... "Framed openings shall be designed to structurally replace the covering and framing displaced." This requirement was not met by SES's original shop drawing submittal therefore requiring the subsequent revised structural sections. It was the contractor's responsibility to propose a design for the building which would meet the specifications.
2. SES was required by the contract to provide shop drawings of the DDSF building's structural design to TAMS for structural review and approval. After review, in TAMS's judgement, the building supplier, Strand Buildings, had not provided sufficient load bearing members around the large roll-up doors to accommodate the potential wind loads required by the specifications. SES was therefore required to modify the building's structural design to increase the strength of the load bearing members. TAMS identified as a possible solution, the welding of a structural "Base" plate to each member to increase their load bearing capacity. SES submitted a revised design incorporating the necessary structural members, of sufficient strength, which was then approved by TAMS.
3. SES solicited bids for the erection of the DDSF prior to TAMS's structural review of the building's shop drawing submittals. SES's contract for this work was based on a performance specification and Innovative's bid was based on the contract drawings supplied by TAMS which were not intended to be the actual shop drawings of the building to be erected. The method of conforming to the performance specifications of this work was SES's responsibility. The shop drawings submitted as the chosen alternative to meet the performance specification were not approved by the Engineer and, therefore, SES was contractually required to revise the plans to meet the specifications as determined by the Engineer.

Taking the above facts into consideration, the NYSDEC decides against SES's claim that they are entitled to the \$3,885.65 claimed by Innovative for the additional costs to attach the exterior wall sheeting.

If there are any questions, please contact Mr. Robert W. Schick, P.E. or Philip G. Waite, P.E. of my staff, at 518/457-4343.

Sincerely,



Michael J. O'Toole, Jr., P.E.
Director
Division of Hazardous Waste Remediation

cc: R. Elia
J. Fiteni
D. Melancon

W. Melancon

New York State Department of Environmental Conservation
50 Wolf Road, Albany, New York 12233



Thomas C. Jorling
Commissioner

JUN - 8 1990

Mr. Kim Lickfield
Project Manager
Sevenson Environmental Services, Inc.
2749 Lockport Road
Niagara Falls, NY 14302

FILE COPY

Re: Black and Bergholtz Creeks Remediation, Love Canal, Niagara County
Site No. 9-32-020, Contract No. D001939

Dear Mr. Lickfield:

Sevenson Environmental Services, Inc.'s (SES) February 20, 1990 letter addressed to Commissioner Thomas C. Jorling of the New York State Department of Environmental Conservation (NYSDEC) has been reviewed. This letter sets forth an appeal under Article 16 of the General Conditions entitled "Disputes", of the above referenced contract. The appeal is concerned with the decision of TAMS Consultants, Inc. regarding the installation of wall panels in the Decontamination/Drum Storage Facility (DDSF). The NYSDEC considers SES's February 20, 1990 letter and its enclosures as SES's opportunity to be heard, and as such it presents all evidence in support of this appeal.

SES in its appeal, presents the following rebuttal to TAMS's February 15, 1990 letter disallowing a change order for the costs to install the wall panels over the insulation in the decontamination bay and the DDSF office:

1. SES's estimator had included the cost of the wall panel materials in his bid, however he did not include the cost for installation.
2. SES's subcontractor, Innovative Building Systems Erection Company (Innovative), responsible for the DDSF erection, was unaware that it was SES's intention that the wall panels were not to be installed, and therefore went ahead with the installation on all wall sides except the north side of the south wall of the drum storage bay.
3. SES claims that installing the wall panels was a benefit to the NYSDEC because the insulation in the decontamination bay (high pressure water wash area with an environment of high humidity and water vapor) would have been ruined quickly without the wall panels.
4. SES claims that since the NYSDEC benefited from their mistake, they should be reimbursed at least for the erection costs of installing the wall panels. As stated in SES's February 20, 1990 letter, these costs amount to \$4,450.77.
5. SES indicates that the construction drawings, and the specifications, do not call for wall panels at the interior wall of the DDSF or the DDSF office. SES also claims that the specification quoted by TAMS in their February 15, 1990 letter (Section 13125, paragraph 11.5) does not apply to this situation and refers instead to neat appearance of exposed insulation not covered by wall panels.

The NYSDEC has considered the arguments put forth by SES and the responses by TAMS and the provisions of the contract and the interpretations thereof. In evaluating the appeal, the following facts have been taken into consideration:

1. The fact that SES's subcontractor installed the wall panels prior to SES informing them that SES did not want the panels installed is not the fault of the NYSDEC. Oversight of subcontractors is clearly the responsibility of SES.
2. Section 13125, paragraph 11.5.2 of the specifications reads: "Blanket insulation may be used in concealed areas in lieu of rigid or semirigid type. ..." The NYSDEC feels that this wording does indeed relate to the installation of the wall panels and requires the contractor to install wall panels over this type of insulation as was installed in the DDSF office and the decontamination bay walls. The fact that the specifications identify the requirement for the panels is not changed by the fact that the construction drawings do not specifically show wall panels since the choice of insulation was left up to SES and/or its subcontractor.

Taking the above facts into consideration, the NYSDEC feels that SES has not provided sufficient justification for reimbursement of their costs of \$4,450.77 to install the wall panels in the DDSF. Therefore the NYSDEC denies SES's request for reimbursement of these costs.

If there are any questions, please contact Mr. Robert W. Schick, P.E. or Philip G. Waite, P.E. of my staff, at (518) 457-4343.

Sincerely,



Michael J. O'Toole, Jr., P.E.
Director
Division of Hazardous Waste Remediation

cc: R. Elia
J. Fiteni
D. Melancon

New York State Department of Environmental Conservation
50 Wolf Road, Albany, New York 12233

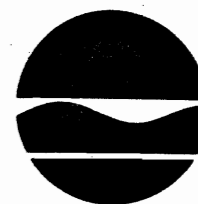

Thomas C. Jorling
Commissioner

RECEIVED

MAR 02 1990

TAMS CONSULTANT, INC.

FILE COPY

Mr. Kim Lickfield
Project Manager
Sevenson Environmental Services, Inc.
2749 Lockport Road
Niagara Falls, NY 14302

Dear Mr. Lickfield:

Re: Black and Bergholtz Creeks Remediation, Love Canal, Niagara County
Site No. 9-32-020, Contract No. D001939

Sevenson Environmental Services, Inc.'s (SES) October 16, 1989 (attached) letter addressed to Commissioner Thomas C. Jorling of the New York State Department of Environmental Conservation (NYSDEC) has been reviewed. This letter sets forth an appeal under Article 16 of the General Conditions entitled "Disputes", of the above referenced contract. The appeal is concerned with the decision of Mr. Robert W. Schick, P.E. regarding withholding a portion of the full payment for SES's work in installing a Meteorological Station (Met. Station) as required under paragraph 9.7 of the Health and Safety requirements (Section 01035 of specifications) for this contract. The NYSDEC considers SES's October 16, 1989 letter and its enclosures as SES's opportunity to be heard, and as such it presents all evidence in support of this appeal.

The NYSDEC has considered the arguments put forth by SES and the responses by Mr. Schick and the provisions of the contract and the interpretations thereof. In evaluating the appeal, the following facts have been taken into consideration:

1. Paragraph 9.7.1 of Section 01035 of the contract specifications includes the following requirement:

"The equipment and its placement shall be in conformance with USEPA Ambient Monitoring Guidelines for Prevention of Significant Deterioration (PSD) standards for horizontal wind speed and direction as specified on PSD regulations promulgated by EPA under the Clean Air Act Amendments of 1977 (Public Law [P.L.] 95-95, August 7, 1980)."

2. PSD standards require the wind speed and direction sensor as well as other equipment to be a minimum of 10 meters (33 feet) above the ground.

3. On August 9, 1988 it was discovered that the height of the Met. Station was only 23 feet and SES was informed that day that the Met. Station did not conform to the specifications.
4. Not until October 8, 1988 did SES raise the Met. Station to the minimum required height of 33 feet. Therefore, from July 19, 1988 (date when Met. Station became operational) through October 8, 1988, the meteorological information gathered by the Met. Station could not be considered true and accurate as based on PSD standards and therefore the installation did not conform to the specifications.
5. On August 1, 1988 basement excavation began. It is this date that accurate air monitoring data was necessary.

Having given due consideration to the position as stated by SES, and in consideration of the factors presented above, the NYSDEC has made a determination as follows:

SES should not be paid for the period between August 1, 1988, the date the beginning of accurate air monitoring was required, and October 8, 1988, the date the mast of the Met. Station was raised to the required height.

Based on the above determination, the amount to be reimbursed to SES is calculated as follows:

Date Met. Station was installed	= Jul. 19, 1988
Date Met. Station was brought into conformance with Specs.	= Oct. 8, 1988
Number of days not in conformance	= 81 days
Amount currently being withheld	= \$1,464.00 or \$18.07 per day
Date commencement of accurate air monitoring was required	= Aug. 1, 1988
Date Met. Station was brought into conformance with Specs.	= Oct. 8, 1988
Number of days not in conformance	= 69 days
Final amount to be withheld at \$18.07 per day	= \$1,246.83
Final amount to be reimbursed \$1,464.00 - \$1,246.83	= \$ 217.17
	Say \$ 218.00

Therefore, the NYSDEC agrees to reimburse SES the amount of \$218.00. This amount should be claimed on the next payment application. The amount of \$1,246.00 remains withheld due to nonconformance with the specifications.

Mr. Kim Lickfield

Page 3

If there are any questions, please contact Mr. Robert W. Schick, P.E. or Philip G. Waite, P.E. of my staff, at (518) 457-4343.

Sincerely,



Michael J. O'Toole, Jr., P.E.
Director
Division of Hazardous Waste Remediation

Attachment

cc:w/att. R. Elia
J. Fiteni
D. Melancon



~~Mr. Sullivan~~
TUS sig.

October 16, 1989

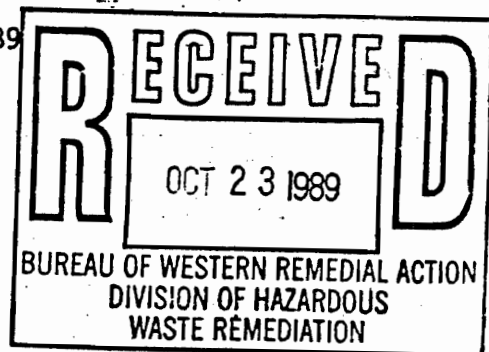

NEW YORK STATE DEPARTMENT
OF ENVIRONMENTAL CONSERVATION
50 Wolf Road
Albany, New York 12233

ATTENTION: Thomas C. Jorling
Commissioner

REGARDING: LOVE CANAL
Black and Bergholtz Creek Remediation
Contract # D-001939
ARTICLE 16 -- DISPUTES

OCT 19 1989

Gentlemen:

In accordance with Article 16 -- Disputes, we hereby appeal the decision rendered by Mr. R. Schick, NYSDEC, in regards to the withholding of monies for the Met. Station.

Mr. Schick has withheld \$1,464.00 for the Met. Station because the "NYSDEC still maintain(s) that Sevenson is not entitled to the full costs for the Met. Station since it was not functioning per the specifications" (for the initial three months of the project). The Met. Station was ordered at the start of the project in April 1988. The initial delivery of the Met. Station equipment was shipped on June 9, 1988. The assembly of the Station proceeded once the Station arrived. On June 30, 1988, the remaining parts were shipped from a back order. When these parts were received, they were installed, and the debugging process began in July 1988, which is indicated in our May 1, 1989 letter to Mr. Schick (copy enclosed).

We feel we should not be penalized for not providing a Meteorological Station, fully operational, upon the Notice to Proceed date of this contract. This unit is quite sophisticated and required three months to receive all the parts to make it operational. Once the unit was received, we expedited its installation so that we were in full compliance with the specifications. This unit has been operational since that time. We have, from time to time, repaired and maintained the Station to insure its compliance with the specifications.

S

NEW YORK STATE DEPARTMENT
of ENVIRONMENTAL CONSERVATION
ATTENTION: Thomas C. Jorling, Commissioner

October 16, 1989
Page Number 2

We feel we have completely fulfilled the requirements of the specifications (provided an operating Met. Station) and therefore expect to be fully compensated as outlined in the specifications.

We have enclosed two invoices from Campbell Scientific which indicate the dates the Met. Station components were shipped to us.

We request you review our claim and respond accordingly.

Sincerely,

SEVENSON ENVIRONMENTAL SERVICES

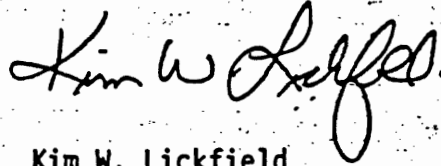

Kim W. Lickfield
Project Manager

KWL/mc
cc: File
R. Elia

Encls.

D. Melancon

New York State Department of Environmental Conservation
50 Wolf Road, Albany, New York 12233

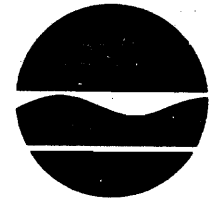

Thomas C. Jorling
Commissioner

FILE COPY

FEB 16 1990

RECEIVED

FEB 23 1990

TAMS CONSULTANT, INC.

Mr. Kim Lickfield
Project Manager
Sevenson Environmental Services, Inc.
2749 Lockport Road
Niagara Falls, NY 14302

Re: Black and Bergholtz Creeks Remediation, Love Canal, Niagara County
Site No. 9-32-020, Contract No. D001939

Dear Mr. Lickfield:

Sevenson Environmental Services, Inc.'s (SES) July 13, 1989 letter addressed to Commissioner Thomas C. Jorling of the New York State Department of Environmental Conservation (NYSDEC) has been reviewed. This letter sets forth an appeal under Article 16 of the General Conditions entitled "Disputes", of the above referenced contract. The appeal is concerned with the decision rendered by TAMS Consultants, Inc. (TAMS) in the matter of Article 10 "Inspection and Acceptance" of the General Conditions of the contract. SES's July 13, 1989 letter and its enclosures presents all evidence in support of SES's appeal.

SES contends that the inspector from Goldberg Zoino and Associates (GZA), subconsultants working for TAMS, should have been inspecting the work as it progressed during the repair of the existing 40 mil HDPE liner along the east side of the Dewatering Containment Facility (DCF) rather than waiting several days after the liner repair had been completed, during which time the work had been silted over, and then requesting the liner be cleaned for the inspection. SES further contends that this delay in the engineer's inspection resulted in over \$1,000.00 of time and material expenses by SES.

The NYSDEC has considered the arguments put forth by SES, the responses by TAMS and GZA's inspector, and the provisions of the contract and interpretations thereof. In evaluating the appeal, the following facts have been taken into consideration:

- The GZA inspector was unable to make adequate "on-going" inspections of the liner repair due to the fact that other inspection duties relating to the construction of the DCF were occupying the majority of his time.
- After SES indicated the liner repairs were satisfactorily completed, the liner was then adequately cleaned for final inspection by SES. At that time, during final inspection, additional holes and tears were discovered needing repair. SES was ordered to perform the repair at which time they did to the satisfaction of the Engineer.

- Paragraph 10.6 of Article 10 "Inspection and Acceptance" states:

"Should the Engineer determine at any time before acceptance of the entire work to examine work already completed and accepted by removing, uncovering or testing the same, the Contractor shall, upon request, promptly furnish all necessary equipment, labor and materials to conduct such inspection, examination or test. If such work is found to be defective or nonconforming in any respect, the Contractor shall defray all the expenses of such examination and satisfactory reconstruction."

Based on the above analysis, additional payment for providing services to clean the HDPE liner so that the Engineer could perform the final inspection is not justified under the contract provisions. Therefore the NYSDEC denies the SES appeal and additional payment will not be made to compensate SES for this work.

If there are any questions, please contact Mr. Robert W. Schick, P.E. or Philip G. Waite, P.E. of my staff, at (518) 457-4343.

Sincerely,



Michael J. O'Toole, Jr., P.E.
Director
Division of Hazardous Waste Remediation

cc: R. Elia
J. Fiteni
D. Melancon



~~Mr. Gerstman
AA
Mr. Sullivan
J. Pagnoni '9~~

July 13, 1989

NEW YORK STATE DEPARTMENT
OF ENVIRONMENTAL CONSERVATION
50 Wolf Road
Albany, New York 12233

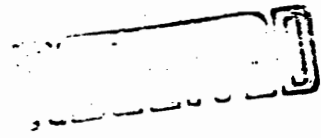

Attention: Thomas C. Jorling
Commissioner

JUL 19 1989

Regarding: NYSDEC - Love Canal
Black and Bergholtz Creek Remediation
Contract No. D 001939
ARTICLE 16 - DISPUTES

Gentlemen:

In accordance with Article 16 - DISPUTES we hereby appeal the decision rendered by TAMS CONSULTANTS, INC. in regards to the non-payment for additional work performed as directed by the Engineer.

According to our contract, the soil materials outside the east berm had to be removed to the existing HDPE liner so that clay could be placed at this location for the construction of the Love Canal "Landfill". During this excavation process the existing HDPE Liner was knicked by the machines excavating the soils. The existing HDPE liner was cleaned and repairs to the liner were performed to bring the existing HDPE liner back to its original condition. During this period of excavation and repairs several rains occurred which placed water and silts on the existing liners. This process continued for the entire length of the landfill. As we were preparing to place clay on the exposed existing liner, Mr. K. May of GOLDBERG ZOINO ASSOCIATES notified us the liner required cleaning (removal of dust and silts) so that he could make his final inspection of the work.

We contend Mr. May should have been making his inspections as the work progressed and not waiting several days later, once the liner had been silted, then requesting the liner be cleaned for his inspection. This delay in the inspection performed by the Engineer resulted in over \$1000.00 of time and material expended by us due to this "after the fact" type of inspection.

5

We therefore request payment for providing services to clean the HDPE liner so that the Engineer could inspect this liner several days after the work was performed.

We have enclosed correspondence regarding the above claim for your review.

Sincerely,

SEVENSON ENVIRONMENTAL
SERVICES, INC.

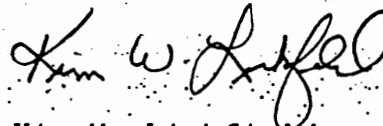

Kim W. Lickfield
Project Manager

KWL28:bg

cc: File
R. Elia
D. Melancon

TO MR. FRAUM FRACASSI

DATE 7/5/89

SES

SUBJECT TSM SH. NO. 03758

BPA CREEKS REMEDIATION

FOR RECLEANING 40 MIL HDPE EXISTING LINER

MESSAGE

THE ABOVE REFERENCED 'ADDITIONAL WORK' TSM CHARGES ARE NOT CONSIDERED BY THE ENGINEER TO BE ALLOWABLE. THE SURFACE OF 40 MIL LINER WAS NOT ^{PREVIOUSLY} ADEQUATELY CLEANED FOR VISUAL INSPECTION AND APPROVAL. THEREFORE THE AREA IN QUESTION WAS REQUESTED TO BE CLEANED FOR FURTHER EXAMINATION, WHICH RESULTED IN ADDITIONAL LINER REPAIRS. (REFERENCE ARTICLE 10.6 OF GENERAL CONDITIONS.

SIGNED D. W. Melanson

REPLY

TO TAMS

FROM



Sevenson
Containment
Corporation

2749 LOCKPORT ROAD
NIAGARA FALLS, N.Y. 14302
(716) 284-0431

SUBJECT 40 ML LINEIC REPAIRS

DATE 6/23/89

MESSAGE WE HAVE FINISHED REPAIRS ALONG THE EAST SIDE OF THE EAST BEEM. AS THE SOIL WAS REMOVED FROM THE LINIC, THE REPAIR AREAS WERE LOCATED BY GUNDRLE. AS THE REPAIRS WERE MADE, THE Q/C WAS PERFORMED AND WE ARE NOW READY TO PLACE CLAY. AS YOU ARE AWARE, SEVERAL RAINS HAVE HIT THE LINIC AND IT HAS BEEN SOAKED SEVERAL TIMES TO REMOVE THE DIRT + EXCESS WATER. YOU ARE ALSO AWARE THAT DEC HAS ORDERED US NOT TO DRIVE OVER THE GRASS REPLY TO ACCESS THIS AREA, SO IT IS IMPORTANT THAT THIS AREA BE COVERED IMMEDIATELY. YOU ARE AWARE WE HAVE TRIED FOR OVER TWO WEEKS TO ACCOMPLISH THIS. WE HAVE BEEN NOTIFIED BY KEN MAY OF GZA THAT THE ENTIRE AREA HAS TO BE RECLEANED SO HE CAN INSPECT THE ENTIRE LINIC. IN OUR OPINION, AND IT HAS BEEN STATED SEVERAL TIMES, THAT THE INSPECTION MUST OCCUR AS THE

SIGNED

DATE / /

SEND PARTS 1 AND 3 WITH CARBON INTACT -
PART 3 WILL BE RETURNED WITH REPLY.

DETACH AND FILE FOR YOUR FOLLOW UP

F
R
O
M



Sevenson
Containment
Corporation

2749 LOCKPORT ROAD
NIAGARA FALLS, N.Y. 14302
(716) 284-0431

SUBJECT 40 ML LINER REPAIRS PAGE 2

DATE 6/23/89

MESSAGE WORK IS PROCEEDING NOT AT THE END. THE LINER WAS REPAIRED SYSTEMATICALLY, SOUTH TO NORTH AND AMPLE TIME WAS AVAILABLE TO INSPECT THE SAME. WE ARE READY TO COVER THE LINER NOW. SHOULD YOU DEEM IT NECESSARY TO CLEAN THE ENTIRE LENGTH OF THE LINER WE EXPECT TO BE PAID FOR THE CLEANING TIME AND FOR ANY OTHER DELAYS SHOULD THE RAINS COME BEFORE THE CLAY IS PLACED. ALSO PLEASE NOTE THAT ~~SIGNED~~ WHEN THE 40 ML REPAIRS WERE MADE REPLY IN THE SOUTHERN AREAS ALONG THE EAST BERM, 2 INSPECTORS WERE ON SITE, ONE DEVOTED TO FULL TIME INSPECTION OF THE WORK.

SIGNED

DATE 6/23/89

SEND PARTS 1 AND 3 WITH CARBON INTACT -
PART 3 WILL BE RETURNED WITH REPLY.

DETACH AND FILE FOR YOUR FOLLOW UP

DATE 6-23 DAY F TYPE WORK 31 CO JOB NO E103 W.O. REF. OR CODE NO. PROJECT NAME LOVE CANAL

WORK BEING PERFORMED FOR: NYSDEL

RE COMPANY P.O. NO.

EMPLOYEE NO. (SOCIAL SECURITY NO.)	HR AS CLASS	EMPLOYEE NAME (LIST EMPLOYEES IN GROUPS BY CLASSIFICATIONS)	DATE INCL. UNDER EMP. CONTRIB.	TOTAL HOURS	BY	BY	BY	BY	BY	DOLLAR AMOUNT
	L	W Cole	31 ⁰⁶	3	X	3				93 ¹⁸
	L	J CARUBBA	31 ⁰⁶	3	K	3				93 ¹⁸
	L	RANDOLPH	31 ⁰⁶	2	K	2				62 ¹²
	S	W KOSTUK	28 ²⁰	2	X	2				57 ⁰⁰
										306 ²⁸
										20 ⁶³
										1070 ⁰⁴
										336 ⁹¹
										1070 ^P
										336 ⁶⁹
										370 ⁶⁰
										01 ¹⁵
										745 ²¹
TOTAL										457 ⁷⁶

TOTAL COMPANY EQUIPMENT	18 ¹⁵
TOTAL LABOR	457 ⁷⁶
TOTAL RENTAL EQUIPMENT	90 ⁷⁵
TOTAL MATERIAL	550 ⁻
GRAND TOTAL TODAY	\$1110 ⁶⁶
SUMMARY OF TODAY'S WORK COMPLETED: (EXACT AND IN DETAIL)	
DECLAN 40' LINER	
HOPE LINER FOR	
ENGR INSPECTION	
WHICH WAS NOT PERFORMED	
DURING ORIG. REPAIRS	
TO THE LINER.	

NOTABLE: Business Form No. 010-073 (1-64)

COMPANY EQUIPMENT WORKING TODAY

TYPE OF EQUIPMENT	THIS JOB NO. TRANSFERRED TO	DATE	1200 HOURS	1200 HOURS	DOLLAR AMOUNT
TRUCK #44		5-	3		15 ⁻
			1070 ⁰⁴		1 ⁰⁰
			1070 ^P		16 ⁵⁰
					18 ¹⁵

EXACT LOCATION OF THIS WORK? LINER (40' LINER) EAST OF THE DCF

WHY IS THIS WORK BEING PERFORMED BY COMPANY AND NOT BY THE CUSTOMER?

WORK ORDER REQUESTED BY _____

SUBCONTRACTOR FAILED TO MEET PROMISED DELIVERY DATE OF _____ (DATE) MADE BY _____ (VENDOR REP.) ON _____ (DATE)

SUBCONTRACTOR REFUSED TO DO WORK HEREIN.

RENTAL EQUIPMENT WORKING TODAY

VENDOR NAME	TYPE OF EQUIP.	P. O. OR P. S.	DATE	1200 HOURS	1200 HOURS	DOLLAR AMOUNT
COMPRESSOR			50/DAY	3		50 ⁻
GENERATOR			25/DAY	3		25 ⁻
			1070 ⁰⁴			
			1070 ^P			

TOTAL RENTAL EQUIPMENT COST → 90⁷⁵

NOTIFIED BY MR. _____ CO REPRESENTATIVE

AND IS IN AGREEMENT.

DISAGREEMENT WITH THIS WORK BEING DONE FOR THE FIRM. REASON GIVEN BY CUSTOMER DISAGREES: _____

MATERIAL AND/OR SERVICES RECEIVED TODAY

VENDOR NAME	1200 VENDOR NUMBER	DESCRIPTION	P. O. OR P. S. NO.	INVOICE NO.	DATE	UNIT PRICE	DOLLAR AMOUNT
BUNDLE	2 TECH	3 OT HRS EA = 6 HRS @ 50					300 ⁻
BUNDLE	2 TECH	2 OT HRS EA = 4 HRS @ 50					200 ⁻
TOTAL							500 ⁻

MATERIAL COST → 500⁻

FOR THIS REPORT FOR SUPERVISOR

(Signature) VERIFIED

ACCEPTANCE-CUSTOMER REPRESENTATIVE SIGNATURE TITLE

0-4-1970

TURN IN ALL COPIES OF THIS REPORT TO OUR MAIN OFFICE TODAY.

ACCOUNTS RECEIVABLE COPY

550 ONLY FOR CONCEPT. HURTS - DO NOT CONCERN FOR

FILE COPY

New York State Department of Environmental Conservation
50 Wolf Road, Albany, New York 12233

RECEIVED

MAY 21 1990

MAY 16 1990

TAMS CONSULTANT, INC.

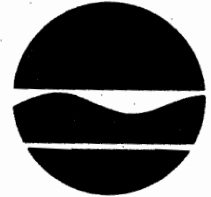

Thomas C. Jorling
Commissioner

Mr. Kim Lickfield
Project Manager
Sevenson Environmental Services, Inc.
2749 Lockport Road
Niagara Falls, NY 14302

Re: Black and Bergholtz Creeks Remediation, Love Canal, Niagara County
Site No. 9-32-020, Contract No. D001939

Dear Mr. Lickfield:

Sevenson Environmental Services, Inc.'s (SES) May 31, 1989 letter addressed to Commissioner Thomas C. Jorling of the New York State Department of Environmental Conservation (NYSDEC) has been reviewed. This letter sets forth an appeal under Article 16 of the General Conditions entitled "Disputes", of the above referenced contract. The appeal is concerned with the decision rendered by TAMS Consultants, Inc. (TAMS) regarding the discharge of turbid water into Cayuga Creek from the Bergholtz Creek remediation. (Specification Section 02415). The NYSDEC considers SES's May 31, 1989 letter and its enclosures as SES's opportunity to be heard, and as such it presents all evidence in support of this appeal.

SES in its appeal, contends that TAMS took no exception to SES's Waste Water Management (WWM) Plan submitted on June 16, 1988 as the plan related to the handling of water in Bergholtz Creek below elevation 562.00. SES's June 16, 1988 WWM Plan proposed treatment, via a sand filter, of any water below elevation 562.00 which failed a turbidity criteria test. Any water that passed this turbidity criteria test was to be discharged directly to Cayuga Creek without treatment. SES claims that TAMS reversed their previous approval of SES's June 16, 1988 WWM Plan relating to water treatment below elevation 562.00 during an April 19, 1989 meeting, at which time SES was directed to treat the water below elevation 562.00 regardless of its turbidity. Treatment has to be by an approved method or through the use of the facilities at the Love Canal site identified by the specifications. The stated basis for SES's claim is its interpretation of Section 02415, paragraph 4.1.1 of the Specifications. SES contends that since the paragraph uses the wording "...to an acceptable level..." and "prior to discharging into Cayuga Creek..." that a determination as to the degree of turbidity in that water below elevation 562.00 should be made prior to requiring treatment of the water before discharge to the Cayuga Creek. It is SES's claim that if the turbidity of the water below elevation 562.00 was not above a certain acceptable level then no treatment was necessary.

The following facts have been considered in determining if SES has a valid claim:

1. In the first response to SES's draft WWM Plan from TAMS, dated June 15, 1988, SES was directed to revise and resubmit the WWM Plan as per the attached comments which were written directly on the WWM Plan. On page three under the second paragraph of the topic entitled "Water from the creek dewatering operations" (see enclosure 1): SES stated that "The discharge of water into Cayuga Creek will be visually monitored daily by SES personnel to insure turbidity levels are maintained." TAMS commented in writing directly under that sentence that "water below elevation 562.00 shall not be discharged in Cayuga Creek." This statement indicated to SES that a discharge to Cayuga Creek would not be considered based on an evaluation or monitoring of turbidity levels. Treatment at the source or else transport of this water to the NYSDEC Dewatering Facility was required, as per the specification.
2. SES, in response to TAMS' comments, revised and resubmitted the WWM Plan. In the response to this resubmittal from TAMS dated June 16, 1988, SES was informed that the WWM Plan was "Approved as Noted" with one of the notes stating, "Water treated in Reach C below elevation 562.00 by means of a sand filter system shall have sediment disposed of at DCF." With the previous comments from the day before, this statement was intended to reinforce TAMS' direction that this water was to be transported to the NYSDEC Dewatering Facility or treated at the source, no matter what the turbidity level.
3. Paragraph 4.1.1 of Section 2415 states: "If the discharge from the creek dewatering operation causes excessive turbidity in Cayuga Creek, or if the water elevation in the reach to be dewatered is below elevation 562.00 feet, the water shall either be treated by the Contractor to reduce the turbidity to an acceptable level as specified above prior to being discharged into Cayuga Creek, or shall be transported to the NYSDEC Dewatering Facility." In other words, the only water that was to be treated by the Contractor solely to reduce turbidity was that water above 562.00 which was found to exceed the established "acceptable level" of turbidity. All water below 562.00 was to be either treated before discharge to Cayuga Creek or transported to the NYSDEC Dewatering Facility, regardless of turbidity. It was also specified to contain water within each reach and not to pump from reach to reach. At SES's request, this requirement was reconsidered and it was decided by TAMS and the NYSDEC to allow SES to pump water from Reaches A and B into Reach C provided SES then treat all water, both above and below 562.00, collected in Reach C by a sand filter prior to discharge to

Mr. Kim Lickfield

Page 3

Cayuga Creek. This concession eliminated the need for turbidity control at each reach, as well as the need to transport water from the creeks to the Love Canal site for treatment, thus facilitating the dewatering process and helping SES complete the project on schedule.

In consideration of the above facts, the NYSDEC decides against SES's claim that they should have been allowed to test for turbidity and thus determine if the water below elevation 562.00 was to be treated or discharged without treatment directly to Cayuga Creek. This determination is based upon the specified need to treat all water below elevation 562.00 as per Section 2415, Paragraph 4.1.1.

If there are any questions, please contact Mr. Robert W. Schick, P.E. or Philip G. Waite, P.E. of my staff, at (518) 457-4343.

Sincerely,

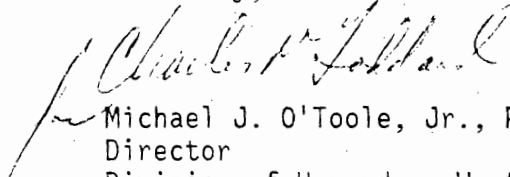

Michael J. O'Toole, Jr., P.E.
Director
Division of Hazardous Waste Remediation

cc: R. Elia
J. Fiteni
D. Melancon

New York State Department of Environmental Conservation
50 Wolf Road, Albany, New York 12233



Thomas C. Jorling
Commissioner

FILE COPY

RECEIVED

MAR 02 1990

TAMS CONSULTANT, INC.

Mr. Kim Lickfield
Project Manager
Sevenson Environmental Services, Inc.
2749 Lockport Road
Niagara Falls, NY 14302

Dear Mr. Lickfield:

Re: Black and Bergholtz Creeks Remediation, Love Canal, Niagara County
Site No. 9-32-020, Contract No. D001939

Sevenson Environmental Services, Inc.'s (SES) May 30, 1989 (attached) letter addressed to Commissioner Thomas C. Jorling of the New York State Department of Environmental Conservation (NYSDEC) has been reviewed. This letter sets forth an appeal under Article 16 of the General Conditions entitled "Disputes", of the above referenced contract. The appeal is concerned with the decision rendered by TAMS Consultants, Inc. (TAMS) regarding the installation of traffic control signs at the intersection of 91st Street and Cayuga Drive. The NYSDEC considers SES's May 30, 1989 letter and its enclosures as SES's opportunity to be heard, and as such it presents all evidence in support of this appeal.

The NYSDEC has considered the arguments put forth by SES and the responses by TAMS, the NYSDEC on-site construction inspector and the provisions of the contract and interpretations thereof. In evaluating the appeal, the following facts have been taken into consideration:

1. SES installed the construction limit chain link fence in the location shown on the construction drawings.
2. It was only after the fence was erected that the problem concerning sight distance at the intersection became apparent.

Having given due consideration to the position as stated by SES, and in consideration of the factors presented above, the NYSDEC has made a determination as follows:

SES cannot be liable for that which it was not aware and which reasonably could not be aware of until after the bid was made.

Based on the above considerations and facts, the NYSDEC finds that SES is entitled to full compensation for both labor and material costs to install the traffic control signs.

Mr. Kim Lickfield

Page 2

Therefore, the NYSDEC agrees to fully reimburse SES for this cost. Once the actual costs of the sign installation are submitted and approved by the Engineer, authorization for payment will be granted.

If there are any questions, please contact Mr. Robert W. Schick, P.E. or Philip G. Waite, P.E. of my staff, at (518) 457-4343.

Sincerely,

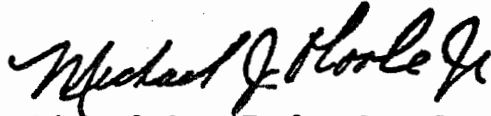

Michael J. O'Toole, Jr., P.E.
Director
Division of Hazardous Waste Remediation

Attachment

cc:w/att.- R. Elia
J. Fiteni
D. Melancon

N. Sullivan
A.A.

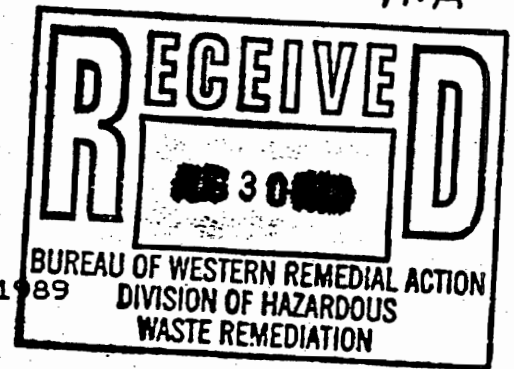

May 30, 1989

NEW YORK STATE DEPARTMENT
OF ENVIRONMENTAL CONSERVATION
50 Wolf Road
Albany, New York 12233

ATTN: Thomas C. Jorling
Commissioner

RE: LOVE CANAL - Black and Bergholtz
Creek Remediation
Contract No. D001939
Article 16 - DISPUTES

JUN. 2 1989

Gentlemen:

In accordance with Article 16 - DISPUTES, we hereby appeal the decision rendered by TAMS CONSULTANTS, INC. in regards to the installation of signs at the intersection of 91st Street and Cayuga Drive.

During the installation of the fence work along Cayuga Drive (Contract Drawing Nos. 111 and 112) the NYSDEC became aware that a potential problem with the site distance at the intersection had been created (reference NYSDEC letter dated May 4, 1989 from Mr. P. Waite, P.E., NYSDEC to Mr. Davis F. Jaros, P.E. Director, City of Niagara Falls, enclosed). Based upon this information the City of Niagara Falls verbally agreed the signs were required at this intersection.

The NYSDEC proceeded to release information to the news (news release dated May 12, 1989, enclosed) regarding the installation of these signs.

Once these signs were installed by Sevenson Environmental Services (SES) the costs for the installation of the signs were submitted to TAMS CONSULTANTS, INC. for verification so that a Change Order could be issued to reimburse us for our costs for this installation. (SES letter to TAMS dated May 24, 1989 enclosed).

TAMS responded to our May 24, 1989 request for a Change Order noting the supply and installation of the signs was included in Specification Section 01570, Paragraph 2.1 and therefore is not allowable to be processed as a Change Order.

S

We responded to TAMS letter on May 25, 1989 (SES letter enclosed) noting the specification section and paragraphs referenced by TAMS refers to the temporary signing required when closing or restricting the public streets or highways. We feel no temporary or permanent signing is required at this intersection. Additionally, the contract drawings do not indicate this signing is required.

We contend this is a design flaw, the fence limiting sight distances, and we should be compensated for the installation of signs as directed by the NYSDEC.

Again we reiterate we interpret Specification Section 01570 referencing Traffic Safety and Regulations while the contractor is working "within public roadways." As we are not working in the roadway these signs are not required by contract.

Please review our dispute and resolve it accordingly.

Sincerely,

SEVENSON ENVIRONMENTAL
SERVICES, INC.

Kim W. Lickfield
Project Manager

KWL:bjg

Enclosures

cc: File
R. Elia

D. Melancon



Thomas C. Jorling
Commissioner

New York State Department of Environmental Conservation
50 Wolf Road, Albany, New York 12233

MAR 02 1989

RECEIVED

MAR 07 1989

Mr. Kim W. Lickfield
Sevenson Environmental Services, Inc.
2749 Lockport Road
Niagara Falls, New York 14302

TAMS CONSULTANT, INC.

Dear Mr. Lickfield:

Re: Black and Bergholtz Creek Remediation, Love Canal, Niagara County,
Site No. 9-32-020, Contract No. D001939

Sevenson Environmental Services, Inc.'s (SES) September 30, 1988 letter addressed to Commissioner Thomas C. Jorling of the New York State Department of Environmental Conservation (NYSDEC) has been reviewed. This letter sets forth the appeal under Article 16 of General Conditions entitled, Disputes, of the above referenced contract regarding the decision rendered by TAMS Consultants, Inc. (TAMS) in the matter of Technical Specifications Part I Section 2530 - Dewatering, contained in the contract agreement. The Department considers SES's September 30, 1988 letter and its enclosure as SES's opportunity to be heard, and as such it presents all evidence in support of this appeal.

SES in its appeal, contends that a changed site condition from the work scope defined in the contract was encountered. The basis of SES's contention is that as the basement excavation in the Construction Demolition Debris Cell (CDD) and Dewatering Containment Facility (DCF) areas of the project proceeded northwards, water was encountered in the basements. The water was noted entering basements from the east section of the excavation, similar to a condition encountered during the construction of the Permanent Staging Area (PSA) with the water situation becoming worse as excavation proceeded northward.

The Department has considered the arguments put forth by SES, TAMS's responses and the provisions of the contract and interpretations thereof. In evaluating this appeal, the following facts have been taken into consideration:

- SES has not established in its September 30, 1988 appeal letter, the correlation between the water and water levels in the abandoned sewers, or any other outside source, and the water and water level in the excavated basement.
- The information regarding existing site conditions provided to bidders as Section 2220 and 2530 of the contract indicated that a potential for seepage of ground water into excavations exists.

- Boring log No. GZA-10, within the excavation area of basements 710 through 750, (which is the area under dispute) indicates water at 3'4 feet in borehole, five minutes after completion of drilling. (Refer to Appendix A to the contract).
- Boring logs in the DCF area indicate the presence of moist to wet soils (Refer to Appendix A to the contract).
- Item No. I-8 entitled Dewatering - DCF Area, of the contract provides for dewatering of all construction in the DCF area. It specifically includes compensation for subsurface dewatering, drainage of ponded water, etc.

Based on the above evaluation, the Department does not consider that a changed site condition was encountered by SES and that dewatering of any groundwater encountered is provided for in the contract and therefore, denies the SES's appeal, and will not issue a change order to the contract to compensate SES on this account.

If there are any questions, please contact Mr. Robert W. Schick, P.E. or Amarinderjit S. Nagi, P.E., of my staff, at 518-457-4343.

Sincerely,



Michael J. O'Toole, Jr., P.E.
Director
Division of Hazardous Waste Remediation

AN/tv

cc: R. Elia
J. Fiteni
D. Melancon

D. Melancon



Thomas C. Jorling
Commissioner

New York State Department of Environmental Conservation
50 Wolf Road, Albany, New York 12233

FILE COPY

MAR 06 1989

RECEIVED

MAR 08 1989

TAMS CONSULTANT, INC.

Mr. Kim W. Lickfield
Sevenson Environmental Services, Inc.
2749 Lockport Road
Niagara Falls, New York 14302

Re: Black and Bergholtz Creek Remediation Project, Love Canal, Niagara
County, Site No. 9-32-020, Contract No. D001939

Dear Mr. Lickfield:

Sevenson Environmental Services, Inc.'s (SES) August 26, 1988 letter addressed to Commissioner Thomas C. Jorling of the New York State Department of Environmental Conservation (NYSDEC) has been reviewed in light of additional information provided with your October 17, 1988 letter. SES's August 26, 1988 letter sets forth an appeal under Article 16 of the General Conditions of the Contract entitled, Disputes, regarding the decision rendered by TAMS Consultants, Inc. (TAMS) in the matter of Technical Specifications Part II Section 02500 ASPHALTIC CONCRETE PAVEMENT - Part I - General Para 4 Laboratory, contained in the contract. An opportunity to be heard, and to offer any evidence in support of the appeal was provided to SES by the Department in its October 6, 1988 letter. The Department considers SES's August 26, and October 17, 1988 letters and enclosures of these letters as SES's opportunity to be heard, and as such, it presents all evidence in support of this appeal.

SES in its appeal contends that:

- Per Section 02500 of specification there is an allowance of \$ 4,000.00 to cover the costs of asphalt laboratory.
- Contract specification Section 01800, in particular item II-1 does not include an allowance to cover the costs incurred by hiring an asphalt laboratory.

In accordance with the technical Specification Part II Section 02500 of the contract, SES is to provide an independent testing laboratory selected by the Engineer to perform sampling and testing of materials, as the engineer may request, and the contractor is to include an allowance of \$4,000.00 in the contract price to cover the approved certified laboratory bills. Based upon the actual laboratory bills the contract price is to be adjusted by the amount over or under \$4,000.00.

Mr. Kim W. Lickfield

Page 2.

Based upon the above contract provision the Department denies the SES's appeal and, therefore, no change order to the contract will be issued to compensate SES up to \$4,000.00 for providing the services of an independent laboratory. However, per the provisions of the contract, the contract price will be increased by the increment of the amount of the bills above the \$4,000.00 and decreased by the amount of decrement below \$4,000.00.

If there are any questions, please contact Mr. Robert W. Schick, P.E., or Mr. Amarinderjit S. Nagi, P.E., of my staff, at 518-457-4343.

Sincerely,



Michael J. O'Toole, Jr., P.E.
Director
Division of Hazardous Waste Remediation

AN/tv

cc: R. Elia, SES
J. Fiteni, TAMS
D. Melancon, TAMS

D. Melancon

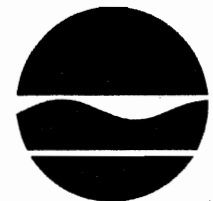

Thomas C. Jorling
Commissioner

New York State Department of Environmental Conservation
50 Wolf Road, Albany, New York 12233

RECEIVED

SEP 19 1988

TAMS CONSULTANT, INC.

FILE COPY

Mr. Kim Lickfield
Project Manager
Sevenson Environmental Services, Inc.
2749 Lockport Road
Niagara Falls, New York 14302

Re: Black and Bergholtz Creek Remediation, Love Canal, Niagara County, Site
No. 9-32-020, Contract No. D001939

Dear Mr. Lickfield:

Your letter of July 1, 1988, addressed to Commissioner Thomas C. Jorling of the New York State Department of Environmental Conservation (Department) has been reviewed. This letter sets forth an appeal, by Sevenson Environmental Services, Inc. (SES), in accordance with the General Conditions, Article 16, entitled, Disputes, of the contract between the Department and SES. The appeal is concerned with the decision rendered by TAMS Consultants, Inc. (TAMS), in the matter of the material specifications found in Section 02400, paragraphs 2.1, 2.2 and 2.4, of the contract. The Department considers the July 1, 1988 letter and enclosures of the letter as SES's opportunity to be heard, and as such, it presents all evidence in support of this appeal.

The basis of the SES appeal is that: (a) the specification calls for "... high density polyethylene (HDPE) pipe, maximum SDR 17, as manufactured by Phillips Driscopipe, Inc., or equal ..."; and (b) that the use of Phillips Driscopipe, Inc., SDR 32.5 HDPE pipe is acceptable, since the use of a lesser grade of pipe, up to the maximum of SDR 17 would meet the specification for use on the project.

The Department has taken under consideration the arguments of SES and TAMS with regard to interpretation of the specification; available product literature; standard definitions of terms relating to plastic piping systems per ASTM F 412 and AWWA C 900; and discussion with distributors of the product. In evaluating this appeal, the following facts were taken into account:

1. Phillips Driscopipe HDPE pipe is available in two series - Series 8600 and 1000. As "maximum SDR 17" or equal HDPE pipe was specified, and as there is no SDR 17 HDPE pipe available in the 8600 series, no ambiguity regarding series designation is evident in the specification.
2. Phillips Driscopipe series identification is analogous to grade designation while Standard Dimension Ratio (SDR) is not. SDR relates to the diameter of pipe divided by pipe wall thickness. The designation of SDR is a term universal to plastic pipe, and has no bearing on the grade of pipe. As series 8600 Driscopipe is the higher "grade" of pipe available, the use of the term grade to differentiate between SDR's is flawed.

3. The use of Dimension Ratio (DR) (equivalent to SDR), or pressure rating, in specifying pipe is necessary information the purchaser must supply in the specifications. In this instance, both SDR and diameter are supplied in the contract documents. By specifying a maximum SDR and the diameter of the pipe, the definition of SDR fixes the minimum pipe wall thickness required. A larger SDR for the same diameter pipe results in a decrease in the pipe wall thickness. SDR 32.5 being greater than the maximum SDR number specified results in a pipe wall thickness less than what is required.

Based upon the above, the Department denies SES's appeal, and therefore, no change order will be issued to compensate SES for complying with the specified requirements of the contract. SES shall provide the required submittals to comply with Section 02400 of the Contract in order to allow this work to proceed without delay.

If there are any questions, please contact Mr. Robert W. Schick, P.E., Chief, Remedial Action Section A at 518-457-4343.

Sincerely,

Michael J. O'Toole, Jr., P.E.
Director
Division of Hazardous Waste Remediation

GTB/tv

cc: J. Fiteni, TAMS
D. Melancon, TAMS ✓
R. Elia, SES

APPENDIX 'A'

SELECT> ENVIRONMENTAL> SERVICES
2235> W. HARRISON> ST.
CHICAGO> ILL. 60612
SEVENSON> CONTAINMENT> LOVE> CANAL

TELEVISION INSPECTION AND GROUTING REPORT

UPSTREAM MANHOLE NUMBER

DOWNSTREAM MANHOLE NUMBER

1

2

STREET NAME : MASON CT
TELEVISION DATE : 07-26-89
TIME OF DAY : 14:03
OPERATOR NUMBER : 0001
PRECIPITATION CONDITION : LIGHT RAIN
GROUND CONDITION : DAMP
SURFACE TYPE : NON-PAVED
PIPE DIAMETER (INCHES) : 18
PIPE DEPTH (FEET) : 05.0
PIPE MATERIAL : VITRIFIED CLAY
TEST PRESSURE : 00.0
LENGTH BETWEEN JOINTS : 03.0
VIDEO TAPE NUMBER : 000001
TAPE STARTING INDEX : 000000
TAPE ENDING INDEX : 000526
COMMENTS :

LEGEND FOR OBSERVATION DATA:

FTG=FOOTAGE
INF=INFILTRATION (GPM)
SR =SEVERITY RATING
TI =TAPE INDEX

PIC=PICTURE NUMBER
JNT=JOINT NUMBER
T =AIR TEST (P=PASS, F=FAIL)
GRT=GROUT AMOUNT

SELECT ENVIRONMENTAL SERVICES
2235 W. HARRISON ST.
CHICAGO ILL. 60612
SEVENSON CONTAINMENT LOVE CANAL

STREET NAME : MASON CT

LINE SEGMENT NUMBER : 1- 2

FTG OBSERVATION INF -SR- TI -PIC- JNT-T- GRT

000.0 UPSTREAM MANHOLE
088.0 LONGITUDINAL CRCK IN PIPE
AT CROWN
110.0 JOINT W/MODERATE OFFSET
116.0 DOWNSTREAM MANHOLE

TOTAL INFILTRATION 0000.00

TOTAL GROUT 0000.0

TOTAL FAILED JOINTS 0000

SELECT>ENVIRONMENTAL>SERVICES
2235>W. HARRISON>ST.
CHICAGO>ILL. 60612
SEVENSON>CONTAINMENT>LOVE>CANAL

TELEVISION INSPECTION AND GROUTING REPORT

UPSTREAM MANHOLE NUMBER

DOWNSTREAM MANHOLE NUMBER

3

4

STREET NAME : 96TH ST & Greenwald Ave.
TELEVISION DATE : 07-27-89
TIME OF DAY : 13:32
OPERATOR NUMBER : 0001
PRECIPITATION CONDITION : NONE
GROUND CONDITION : DRY
SURFACE TYPE : NON-PAVED
PIPE DIAMETER (INCHES) : 27
PIPE DEPTH (FEET) : 09.0
PIPE MATERIAL : CONCRETE
TEST PRESSURE : 00.0
LENGTH BETWEEN JOINTS : 05.0
VIDEO TAPE NUMBER : 000001
TAPE STARTING INDEX : 000527
TAPE ENDING INDEX : 001400
COMMENTS :

LEGEND FOR OBSERVATION DATA:

FTG=FOOTAGE
INF=INFILTRATION (GPM)
SR =SEVERITY RATING
TI =TAPE INDEX

PIC=PICTURE NUMBER
JNT=JOINT NUMBER
T =AIR TEST (P=PASS, F=FAIL)
GRT=GROUT AMOUNT

SELECT ENVIRONMENTAL SERVICES
 2235 W. HARRISON ST.
 CHICAGO ILL. 60612
 SEVENSON CONTAINMENT LOVE CANAL

STREET NAME : 98TH ST

LINE SEGMENT NUMBER : 3- 4

FTG	OBSERVATION	INF	-SR-	TI	-PIC-	JNT	T-	GRT
000.0	UPSTREAM MANHOLE							
008.0	JOINT WITH INFILTRATION TO RIGHT							
021.0	BREAK-IN SERVICE CONNECTN AT CROWN							
025.0	BREAK-IN SERVICE CONNECTN AT CROWN							
078.0	BREAK-IN SERVICE CONNECTN AT CROWN							
087.0	BREAK-IN SERVICE CONNECTN AT CROWN							
123.0	BREAK-IN SERVICE CONNECTN AT CROWN BEGIN OBSERVATION SAG IN PIPE							
132.0	BREAK-IN SERVICE CONNECTN AT CROWN							
160.0	END OBSERVATION SAG IN PIPE							
167.0	DOWNSTREAM MANHOLE							

TOTAL INFILTRATION 0000.00

TOTAL GROUT 0000.0

TOTAL FAILED JOINTS 0000

SELECT>ENVIRONMENTAL>SERVICES
2235>W. HARRISON>ST.
CHICAGO>ILL. 60612
SEVENSON>CONTAINMENT>LOVE>CANAL

TELEVISION INSPECTION AND GROUTING REPORT

UPSTREAM MANHOLE NUMBER

DOWNSTREAM MANHOLE NUMBER

5

6

STREET NAME : 91TH ST
TELEVISION DATE : 07-28-89
TIME OF DAY : 14:32
OPERATOR NUMBER : 0001
PRECIPITATION CONDITION : NONE
GROUND CONDITION : DRY
SURFACE TYPE : NON-PAVED
PIPE DIAMETER (INCHES) : 12
PIPE DEPTH (FEET) : 04.0
PIPE MATERIAL : VITRIFIED CLAY
TEST PRESSURE : 00.0
LENGTH BETWEEN JOINTS : 03.0
VIDEO TAPE NUMBER : 000001
TAPE STARTING INDEX : 001401
TAPE ENDING INDEX : 001862
COMMENTS :

LEGEND FOR OBSERVATION DATA:

FTG=FOOTAGE
INF=INFILTRATION (GPM)
SR =SEVERITY RATING
TI =TAPE INDEX

PIC=PICTURE NUMBER
JNT=JOINT NUMBER
T =AIR TEST (P=PASS, F=FAIL)
GRT=GROUT AMOUNT

SELECT ENVIRONMENTAL SERVICES
 2235 W. HARRISON ST.
 CHICAGO ILL. 60612
 SEVENSON CONTAINMENT LOVE CANAL

STREET NAME : 91TH ST

LINE SEGMENT NUMBER : 5- 6

FTG OBSERVATION INF -SR- TI -PIC- JNT-T- GRT

 000.0 UPSTREAM MANHOLE
 022.0 LONGITUDINAL CRCK IN PIPE
 BEGIN OBSERVATION
 030.0 END OBSERVATION
 LONGITUDINAL CRCK IN PIPE
 042.0 LONGITUDINAL CRCK IN PIPE
 044.0 PIPE CORROSION
 AT INVERT
440 pipe changes material from clay pipe to C.M.P.
 056.0 DOWNSTREAM MANHOLE

 TOTAL INFILTRATION 0000.00

 TOTAL GROUT 0000.0

TOTAL FAILED JOINTS 0000

SELECT>ENVIRONMENTAL>SERVICES
2235>W. HARRISON>ST.
CHICAGO>ILL. 60612
SEVENSON>CONTAINMENT>LOVE>CANAL

TELEVISION INSPECTION AND GROUTING REPORT

UPSTREAM MANHOLE NUMBER

DOWNSTREAM MANHOLE NUMBER

7

8

STREET NAME : 89TH ST
TELEVISION DATE : 07-31-89
TIME OF DAY : 11:32
OPERATOR NUMBER : 0001
PRECIPITATION CONDITION : NONE
GROUND CONDITION : DRY
SURFACE TYPE : NON-PAVED
PIPE DIAMETER (INCHES) : 18
PIPE DEPTH (FEET) : 06.0
PIPE MATERIAL : VITRIFIED CLAY
TEST PRESSURE : 00.0
LENGTH BETWEEN JOINTS : 03.0
VIDEO TAPE NUMBER : 000001
TAPE STARTING INDEX : 001875
TAPE ENDING INDEX : 002266
COMMENTS :

LEGEND FOR OBSERVATION DATA:

FTG=FOOTAGE
INF=INFILTRATION (GPM)
SR =SEVERITY RATING
TI =TAPE INDEX

PIC=PICTURE NUMBER
JNT=JOINT NUMBER
T =AIR TEST (P=PASS, F=FAIL)
GRT=GROUT AMOUNT

SELECT ENVIRONMENTAL SERVICES
 2235 W. HARRISON ST.
 CHICAGO ILL. 60612
 SEVENSON CONTAINMENT LOVE CANAL

STREET NAME : 89TH ST

LINE SEGMENT NUMBER : 7- 8

FTG	OBSERVATION	INF	-SR-	TI	-PIC-	JNT-T-	GRT
000.0	UPSTREAM MANHOLE						
009.0	LONGITUDINAL CRCK IN PIPE BEGIN OBSERVATION						
020.0	BREAK-IN SERVICE CONNECTN TO RIGHT						
029.0	END OBSERVATION LONGITUDINAL CRCK IN PIPE						
047.0	LONGITUDINAL CRCK IN PIPE AT CROWN AT INVERT BEGIN OBSERVATION						
072.0	BROKEN PIPE						
081.0	JOINT WITH SEVERE OFFSET						
087.0	DOWNSTREAM MANHOLE						
	TOTAL INFILTRATION	0000.00					
						TOTAL GROUT	0000.0
						TOTAL FAILED JOINTS	0000

SELECT ENVIRONMENTAL SERVICES
2235 W. HARRISON ST.
CHICAGO ILL. 60612
SEVENSON CONTAINMENT LOVE CANAL

TELEVISION INSPECTION AND GROUTING REPORT

UPSTREAM MANHOLE NUMBER

DOWNSTREAM MANHOLE NUMBER

9

10

STREET NAME : 93TH ST
TELEVISION DATE : 08-01-89
TIME OF DAY : 12:02
OPERATOR NUMBER : 0001
PRECIPITATION CONDITION : NONE
GROUND CONDITION : DRY
SURFACE TYPE : NON-PAVED
PIPE DIAMETER (INCHES) : 18
PIPE DEPTH (FEET) : 09.0
PIPE MATERIAL : VITRIFIED CLAY
TEST PRESSURE : 00.0
LENGTH BETWEEN JOINTS : 03.0
VIDEO TAPE NUMBER : 000001
TAPE STARTING INDEX : 002330
TAPE ENDING INDEX : 002853
COMMENTS :

LEGEND FOR OBSERVATION DATA:

FTG=FOOTAGE
INF=INFILTRATION (GPM)
SR =SEVERITY RATING
TI =TAPE INDEX

PIC=PICTURE NUMBER
JNT=JOINT NUMBER
T =AIR TEST (P=PASS, F=FAIL)
GRT=GROUT AMOUNT

SELECT>ENVIRONMENTAL>SERVICES
 2235>W. HARRISON>ST.
 CHICAGO>ILL. 60612
 SEVENSON>CONTAINMENT>LOVE>CANAL

STREET NAME : 93TH ST

LINE SEGMENT NUMBER : 9- 10

FTG	OBSERVATION	INF	-SR-	TI	-PIC-	JNT-T-	GRT
000.0	UPSTREAM MANHOLE						
003.0	JOINT WITH LIGHT ROOTS AT CROWN						
005.0	JOINT WITH LIGHT ROOTS						
009.0	JOINT WITH LIGHT ROOTS						
015.0	LONGITUDINAL CRCK IN PIPE AT CROWN						
018.0	LONGITUDINAL CRCK IN PIPE AT CROWN AT INVERT						
030.0	BURIED MANHOLE						
064.0	LONGITUDINAL CRCK IN PIPE AT CROWN AT INVERT						
070.0	MISALIGNED JOINT						
071.0	SERVICE CONNECTION TO RIGHT						
074.0	MISALIGNED JOINT LONGITUDINAL CRCK IN PIPE END OBSERVATION						
080.0	DOWNSTREAM MANHOLE						
	TOTAL INFILTRATION	0000.00					
						TOTAL GROUT	0000.0
						TOTAL FAILED JOINTS	0000

SELECT>ENVIRONMENTAL>SERVICES
2235>W. HARRISON>ST.
CHICAGO>ILL. 60612
SEVENSON>CONTAINMENT>LOVE>CANAL

TELEVISION INSPECTION AND GROUTING REPORT

UPSTREAM MANHOLE NUMBER

DOWNSTREAM MANHOLE NUMBER

11

12

STREET NAME : 93TH ST
TELEVISION DATE : 08-04-89
TIME OF DAY : 14:02
OPERATOR NUMBER : 0001
PRECIPITATION CONDITION : LIGHT RAIN
GROUND CONDITION : DAMP
SURFACE TYPE : NON-PAVED
PIPE DIAMETER (INCHES) : 27
PIPE DEPTH (FEET) : 10.0
PIPE MATERIAL : CONCRETE
TEST PRESSURE : 00.0
LENGTH BETWEEN JOINTS : 03.0
VIDEO TAPE NUMBER : 000001
TAPE STARTING INDEX : 003254
TAPE ENDING INDEX : 003434
COMMENTS :

LEGEND FOR OBSERVATION DATA:

FTG=FOOTAGE
INF=INFILTRATION (GPM)
SR =SEVERITY RATING
TI =TAPE INDEX

PIC=PICTURE NUMBER
JNT=JOINT NUMBER
T =AIR TEST (P=PASS, F=FAIL)
GRT=GROUT AMOUNT

SELECT> ENVIRONMENTAL> SERVICES
2235> W. HARRISON> ST.
CHICAGO> ILL. 60612
SEVENSON> CONTAINMENT> LOVE> CANAL

STREET NAME : 93TH ST

LINE SEGMENT NUMBER : 11- 12

FTG	OBSERVATION	INF	-SR-	TI	-PIC-	JNT-T-	GRT
000.0	UPSTREAM MANHOLE						
013.0	BEGIN OBSERVATION						
	SAG IN PIPE						
061.0	END OBSERVATION						
063.0	DOWNSTREAM MANHOLE						

TOTAL INFILTRATION 0000.00 TOTAL GROUT 0000.0

TOTAL FAILED JOINTS 0000

SELECT ENVIRONMENTAL SERVICES
2235 W. HARRISON ST.
CHICAGO ILL. 60612
SEVENSON CONTAINMENT LOVE CANAL

TELEVISION INSPECTION AND GROUTING REPORT

UPSTREAM MANHOLE NUMBER

DOWNSTREAM MANHOLE NUMBER

13

14

STREET NAME : 92ND ST
TELEVISION DATE : 08-05-89
TIME OF DAY : 15:34
OPERATOR NUMBER : 0001
PRECIPITATION CONDITION : NONE
GROUND CONDITION : DRY
SURFACE TYPE : NON-PAVED
PIPE DIAMETER (INCHES) : 21
PIPE DEPTH (FEET) : 09.0
PIPE MATERIAL : CONCRETE
TEST PRESSURE : 00.0
LENGTH BETWEEN JOINTS : 03.0
VIDEO TAPE NUMBER : 000001
TAPE STARTING INDEX : 003675
TAPE ENDING INDEX : 003973
COMMENTS :

LEGEND FOR OBSERVATION DATA:

FTG=FOOTAGE
INF=INFILTRATION (GPM)
SR =SEVERITY RATING
TI =TAPE INDEX

PIC=PICTURE NUMBER
JNT=JOINT NUMBER
T =AIR TEST (P=PASS, F=FAIL)
GRT=GROUT AMOUNT

SELECT ENVIRONMENTAL SERVICES
2235 W. HARRISON ST.
CHICAGO ILL. 60612
SEVENSON CONTAINMENT LOVE CANAL

STREET NAME : 92ND ST

LINE SEGMENT NUMBER : 13- 14

FTG	OBSERVATION	INF	-SR-	TI	-PIC-	JNT	-T-	GRT
000.0	UPSTREAM MANHOLE							
072.0	JOINT W/MODERATE OFFSET							
081.0	DOWNSTREAM MANHOLE							

TOTAL INFILTRATION 0000.00

TOTAL GROUT 0000.0

TOTAL FAILED JOINTS 0000

SELECT>ENVIRONMENTAL>SERVICES
2235>W. HARRISON>ST.
CHICAGO>ILL. 60612
SEVENSON>CONTAINMENT>LOVE>CANAL

TELEVISION INSPECTION AND GROUTING REPORT

UPSTREAM MANHOLE NUMBER

DOWNSTREAM MANHOLE NUMBER

15

16

STREET NAME : 94TH ST
TELEVISION DATE : 08-08-89
TIME OF DAY : 15:34
OPERATOR NUMBER : 0001
PRECIPITATION CONDITION : NONE
GROUND CONDITION : DRY
SURFACE TYPE : NON-PAVED
PIPE DIAMETER (INCHES) : 18
PIPE DEPTH (FEET) : 08.0
PIPE MATERIAL : VITRIFIED CLAY
TEST PRESSURE : 00.0
LENGTH BETWEEN JOINTS : 03.0
VIDEO TAPE NUMBER : 000001
TAPE STARTING INDEX : 004209
TAPE ENDING INDEX : 004665
COMMENTS :

LEGEND FOR OBSERVATION DATA:

FTG=FOOTAGE
INF=INFILTRATION (GPM)
SR =SEVERITY RATING
TI =TAPE INDEX

PIC=PICTURE NUMBER
JNT=JOINT NUMBER
T =AIR TEST (P=PASS, F=FAIL)
GRT=GROUT AMOUNT

SELECT ENVIRONMENTAL SERVICES
 2235 W. HARRISON ST.
 CHICAGO ILL. 60612
 SEVENSON CONTAINMENT LOVE CANAL

STREET NAME : 94TH ST

LINE SEGMENT NUMBER : 15- 16

FTG	OBSERVATION	INF	-SR-	TI	-PIC-	JNT	T-	GRT
000.0	UPSTREAM MANHOLE							
035.0	LONGITUDINAL CRCK IN PIPE							
	AT CROWN							
	AT INVERT							
	BEGIN OBSERVATION							
050.0	JOINT WITH LIGHT ROOTS							
	BEGIN OBSERVATION							
081.0	JOINT WITH LIGHT ROOTS							
	END OBSERVATION							
105.0	LONGITUDINAL CRCK IN PIPE							
	END OBSERVATION							
120.0	DOWNSTREAM MANHOLE							
	TOTAL INFILTRATION	0000.00						
	TOTAL GROUT					0000.0		
	TOTAL FAILED JOINTS							0000

105' pipe causes material from clay pipe to steel pipe

ROBINSON PIPE CLEANING CO.
EIGHTY FOUR PA.
SEVENSON CONTAINMENT CORP
NIAGARA FALLS NY

TELEVISION INSPECTION AND GROUTING REPORT

UPSTREAM MANHOLE NUMBER

DOWNSTREAM MANHOLE NUMBER

17

18

STREET NAME : 91ST BROOKSIDE

TELEVISION DATE : 09-05-89

TIME OF DAY : 10:09

OPERATOR NUMBER : 0001

PRECIPITATION CONDITION : NONE

GROUND CONDITION : DRY

SURFACE TYPE : NON-PAVED

PIPE DIAMETER (INCHES) : 21

PIPE DEPTH (FEET) : 08.0

PIPE MATERIAL : CONCRETE

TEST PRESSURE : 00.0

LENGTH BETWEEN JOINTS : 03.0

VIDEO TAPE NUMBER : 000001

TAPE STARTING INDEX : 000000

TAPE ENDING INDEX : 000000

COMMENTS :

LEGEND FOR OBSERVATION DATA:

FTG=FOOTAGE

INF=INFILTRATION (GPM)

SR =SEVERITY RATING

TI =TAPE INDEX

PIC=PICTURE NUMBER

JNT=JOINT NUMBER

T =AIR TEST (P=PASS,F=FAIL)

GRT=GROUT AMOUNT

ROBINSON PIPE CLEANING CO.
EIGHTY FOUR PA.
SEVENSON CONTAINMENT CORP
NIAGARA FALLS NY

STREET NAME : 91ST BROOKSIDE

LINE SEGMENT NUMBER : 17- 18

FTG OBSERVATION INF -SR- TI -PIC- JNT-T- GRT

000.0 UPSTREAM MANHOLE

017.0 OPEN CODE B *PIPE CHANGES MATERIAL FROM CONCRETE TO STEEL PIPE*

030.0 DOWNSTREAM MANHOLE

TOTAL INFILTRATION 0000.00

TOTAL GROUT 0000.0

TOTAL FAILED JOINTS 0000

ROBINSON PIPE CLEANING CO.
EIGHTY FOUR PA.
SEVENSON CONTAINMENT CORP
NIAGARA FALLS NY

TELEVISION INSPECTION AND GROUTING REPORT

UPSTREAM MANHOLE NUMBER

DOWNSTREAM MANHOLE NUMBER

19

20

STREET NAME : 90TH ST
TELEVISION DATE : 09-05-89
TIME OF DAY : 15:02
OPERATOR NUMBER : 0001
PRECIPITATION CONDITION : NONE
GROUND CONDITION : DRY
SURFACE TYPE : NON-PAVED
PIPE DIAMETER (INCHES) : 21
PIPE DEPTH (FEET) : 07.0
PIPE MATERIAL : CONCRETE
TEST PRESSURE : 00.0
LENGTH BETWEEN JOINTS : 03.0
VIDEO TAPE NUMBER : 000002
TAPE STARTING INDEX : 000000
TAPE ENDING INDEX : 000000
COMMENTS :

LEGEND FOR OBSERVATION DATA:

FTG=FOOTAGE
INF=INFILTRATION (GPM)
SR =SEVERITY RATING
TI =TAPE INDEX

PIC=PICTURE NUMBER
JNT=JOINT NUMBER
T =AIR TEST (P=PASS,F=FAIL)
GRT=GROUT AMOUNT

EIGHTY FOUR PA.
SEVENSON CONTAINMENT CORP
NIAGARA FALLS NY

STREET NAME : 90TH ST

LINE SEGMENT NUMBER : 19- 20

FTG OBSERVATION INF -SR- TI -PIC- JNT-T- GRT

000.0 UPSTREAM MANHOLE
018.0 BREAK-IN SERVICE CONNECTN
AT CROWN
055.0 DOWNSTREAM MANHOLE

TOTAL INFILTRATION 0000.00 TOTAL GROUT 0000.0

TOTAL FAILED JOINTS 0000

ROBINSON PIPE CLEANING CO.
EIGHTY FOUR PA.
SEVENSON CONTAINMENT CORP
NIAGARA FALLS NY

TELEVISION INSPECTION AND GROUTING REPORT

UPSTREAM MANHOLE NUMBER

DOWNSTREAM MANHOLE NUMBER

21

22

STREET NAME : 88TH ST
TELEVISION DATE : 09-06-89
TIME OF DAY : 11:02
OPERATOR NUMBER : 0001
PRECIPITATION CONDITION : NONE
GROUND CONDITION : DRY
SURFACE TYPE : NON-PAVED
PIPE DIAMETER (INCHES) : 12
PIPE DEPTH (FEET) : 03.0
PIPE MATERIAL : CONCRETE
TEST PRESSURE : 00.0
LENGTH BETWEEN JOINTS : 03.0
VIDEO TAPE NUMBER : 000002
TAPE STARTING INDEX : 000000
TAPE ENDING INDEX : 000000
COMMENTS :

LEGEND FOR OBSERVATION DATA:

FTG=FOOTAGE
INF=INFILTRATION (GPM)
SR =SEVERITY RATING
TI =TAPE INDEX

PIC=PICTURE NUMBER
JNT=JOINT NUMBER
T =AIR TEST (P=PASS, F=FAIL)
GRT=GROUT AMOUNT

ROBINSON PIPE CLEANING CO.
EIGHTY FOUR PA.
SEVENSON CONTAINMENT CORP
NIAGARA FALLS NY

STREET NAME : 88TH ST

LINE SEGMENT NUMBER : 21- 22

FTG OBSERVATION INF -SR- TI -PIC- JNT-T- GRT

000.0 UPSTREAM MANHOLE

046.0 DOWNSTREAM MANHOLE

TOTAL INFILTRATION 0000.00

TOTAL GROUT 0000.0

TOTAL FAILED JOINTS 0000

15

New York State Department of Environmental Conservation
Division of Hazardous Waste and Remediation

CHANGE ORDER

Date of Issue: September 18, 1989

Change Order No.:

Change Order Amount:

Contract No.: D-001939

Project Name: Black and Bergholtz Creek Remediation,
Love Canal, Niagara County

NYSDEC Project No.: Site Number 9-32-020

Contractor's Name: Severson Environmental Services, Inc.

I. DESCRIPTION OF CHANGE

Additional foundation construction required for the new crib-type retaining wall that is designed to replace the existing timber bulkhead at station 22+00 to 23+00 along the south bank of Bergholtz Creek. [Reference Contract Dwg. No. 109 and 112]

The existing soft, silty clay layer which underlies the timber bulkhead is to be excavated to a competent foundation as determined by the Engineer (approximate elevation 550) and replaced with Type I gravel backfill which will become the new foundation for the proposed cribwall. This new foundation will extend along the length of the proposed concrete cribwall from the proposed temporary sheeting line (approximately 3 feet from the inside face of the cribwall) to 3 feet beyond the toe of the cribwall.

The work will consist of necessary additional line of sheet piling, field engineering, excavation of unsuitable foundation material, shoring, dewatering and backfilling the excavation. The contaminated creekbed sediments have been removed, therefore the level of worker protection will be considered non-hazardous. The performance of this work will be under the observation of the Owner and the Engineer.

DRAWINGS

Foundation Design Method Statement and Elevation Sketch dated 8/30/89.

SPECIFICATION

All work completed under this change order shall conform to the contract specifications and as ordered by the Engineer.

PAYMENT

Payment for the work as described above will be made on the basis of "estimate of actual cost of labor and materials plus overhead and profit, cost to be determined as the work progresses . . ." in accordance with Sub-article 11.4(c) of Section 071.0 - General Conditions.

II. REASON FOR CHANGE:

Engineering foundation analysis determined that the bearing capacity of existing soil was not adequate to support the design loads of new cribwall.

III. CHANGE IN CONTRACT PRICE

Original Contract Price: \$12,289,250.00

Contract Price after previous Change Order: N/A

*Net Increase due to this Change Order: \$57,237.00

*Preliminary Estimate [See Payment Method]

IV. CHANGE IN CONTRACT CALENDAR DAYS COMPLETION DATE

Original Contract Time 625

Contract Time after
previous Change Order N/A

Net (INCREASE)
due to this Change Order: To be determined

New Contract Time including
this Change Order 625

It is understood and agreed that, unless expressly so stated above, the work herein authorized will not extend the time for the completion of the contract.

This work is to be performed in accordance with the terms of the contract and original plans and specifications, except as herein modified. It is understood and agreed that this order shall be deemed

executory only to the extent of moneys available and no liability shall be incurred by the State beyond the moneys available for the purpose.

APPROVALS

Contractor (Print) Sevenson Environmental Services, Inc.

(Sign) _____ Title: Vice President

Date: _____

Engineer (Print) TAMS Consultants, Inc.

(Sign) _____ Title: Resident Engineer

Date: _____

NYSDEC/Division of Hazardous Waste Remediation

(Print) _____

(Sign) _____ Title: Acting Division Director

Date: _____

NEW YORK STATE DEPARTMENT OF ENVIRONMENTAL CONSERVATION

(Print) _____

(Sign) _____ Title: Director, Div. of Fiscal Mgmt.

Date: _____

For NYS Dept. of Audit and Control Approval

Date: _____

chord918

New York State Department of Environmental Conservation
Division of Hazardous Waste and Remediation

CHANGE ORDER

Date of Issue: September 19, 1989

Change Order No.:

Change Order Amount:

Contract No.: D-001939

Project Name: Black and Bergholtz Creek Remediation,
Love Canal, Niagara County

NYSDEC Project No.: Site Number 9-32-020

Contractor's Name: Severson Environmental Services, Inc.

I. DESCRIPTION OF CHANGE

Provide and install five (5) 3' x 7' mangates in the new perimeter fence at 95th Street of the DCF area. Locations will be as per direction of NYSDEC.

DRAWINGS

N/A

SPECIFICATION

Section 02101 Part I and as ordered by Engineer.

PAYMENT

Payment for the work as described above will be made on the basis of "acceptance of agreed unit prices based on estimated cost plus overhead and profit as applicable . . ." in accordance with sub-article 11.4(b) or Section 071.0 General Conditions.

II. REASON FOR CHANGE:

Requested by NYSDEC in order to provide access to monitoring well clusters located between new 95th Street perimeter fence and DCF Cell.

III. CHANGE IN CONTRACT PRICE

Original Contract Price: \$12,289,250.00

Contract Price after previous Change Order: N/A

Net Increase due to this Change Order: \$2,310.00

IV. CHANGE IN CONTRACT CALENDAR DAYS COMPLETION DATE

Original Contract Time 625

Contract Time after
previous Change Order N/A

Net (INCREASE)
due to this Change Order: 0

New Contract Time including
this Change Order 625

It is understood and agreed that, unless expressly so stated above, the work herein authorized will not extend the time for the completion of the contract.

This work is to be performed in accordance with the terms of the contract and original plans and specifications, except as herein modified. It is understood and agreed that this order shall be deemed executory only to the extent of moneys available and no liability shall be incurred by the State beyond the moneys available for the purpose.

APPROVALS

Contractor (Print) Sevenson Environmental Services, Inc.

(Sign) Title: Vice President

Date: _____

Engineer (Print) TAMS Consultants, Inc.

(Sign) Title: Resident Engineer

Date: _____

NYSDEC/Division of Hazardous Waste Remediation

(Print) _____

(Sign) _____

Title: Acting Division Director

Date: _____

NEW YORK STATE DEPARTMENT OF ENVIRONMENTAL CONSERVATION

(Print) _____

(Sign) _____

Title: Director, Div. of Fiscal Mgmt.

Date: _____

For NYS Dept. of Audit and Control Approval

Date: _____

chord919

New York State Department of Environmental Conservation
Division of Hazardous Waste and Remediation

CHANGE ORDER

Date of Issue: October 16, 1989

Change Order No.:

Change Order Amount:

Contract No.: D-001939

Project Name: Black and Bergholtz Creek Remediation,
Love Canal, Niagara County

NYSDEC Project No.: Site Number 9-32-020

Contractor's Name: Severson Environmental Services, Inc.

I. DESCRIPTION OF CHANGE

Coat the inside of six (6) inch diameter steel leachate transfer pipe to the 10,000 Gallon Storage Tank using Tenemac No. 61 application or equal.

DRAWINGS

Contract Drawing No. 223

SPECIFICATION

All work completed under this change order shall conform to the contract specification Section 02400(I) and as ordered by the Engineer.

PAYMENT

Payment for the work as described above will be made on the basis of "acceptance of agreed unit prices based on estimated cost plus overhead and profit as applicable . . ." in accordance with sub-article 11.4(b) or Section 071.0 General Conditions.

II. REASON FOR CHANGE:

Steel transition pipe and 90 degree elbow connecting the HDPE piping from Manhole No. 7 to 10,000 Gallon Tank drop inlet pipe required coating application. This was necessary in order to maintain the integrity of pipe intake system interior wall protection.

III. CHANGE IN CONTRACT PRICE

Original Contract Price: \$12,289,250.00

Contract Price after previous Change Order: N/A

Net Increase due to this Change Order: \$151.25

IV. CHANGE IN CONTRACT CALENDAR DAYS COMPLETION DATE

Original Contract Time 625

Contract Time after
previous Change Order N/A

Net (INCREASE)
due to this Change Order: 0

New Contract Time including
this Change Order 625

It is understood and agreed that, unless expressly so stated above, the work herein authorized will not extend the time for the completion of the contract.

This work is to be performed in accordance with the terms of the contract and original plans and specifications, except as herein modified. It is understood and agreed that this order shall be deemed executory only to the extent of moneys available and no liability shall be incurred by the State beyond the moneys available for the purpose.

APPROVALS

Contractor (Print) Sevenson Environmental Services, Inc.

(Sign) Title: Vice President

Date: _____

Engineer (Print) TAMS Consultants, Inc.

(Sign) Title: Resident Engineer

Date:

NYSDEC/Division of Hazardous Waste Remediation

(Print)

(Sign) Title: Acting Division Director

Date:

NEW YORK STATE DEPARTMENT OF ENVIRONMENTAL CONSERVATION

(Print)

(Sign) Title: Director, Div. of Fiscal Mgmt.

Date:

For NYS Dept. of Audit and Control Approval

Date:

chord10.16

New York State Department of Environmental Conservation
Division of Hazardous Waste and Remediation

CHANGE ORDER

Date of Issue: October 17, 1989

Change Order No.:

Change Order Amount: \$4,030.00

Contract No.: D-001939

Project Name: Black and Bergholtz Creek Remediation,
Love Canal, Niagara County

NYSDEC Project No.: Site Number 9-32-020

Contractor's Name: Severson Environmental Services, Inc.

I. DESCRIPTION OF CHANGE

Removal/cut-off of approximately thirty (30) 12 inch diameter wooden piles uncovered in creekbed during excavation work below 91st Street Bridge. (Reach C of Creek Remediation Work).

DRAWINGS

N/A

SPECIFICATION

All work completed under this Change Order shall conform to the Contract Specifications and also "As Ordered by the Engineer".

PAYMENT

Payment for the work as described above will be made on the basis of "actual cost of labor and materials plus overhead and profit, cost to be determined as the work progresses . . ." in accordance with Sub-article 11.4(d) of Section 071.0 - General Conditions.

II. REASON FOR CHANGE:

Unknown condition that required removal and/or cut-off of piling at design creekbed subgrade profile so as not to interfere with hydraulics of channel flow.

III. CHANGE IN CONTRACT PRICE

Original Contract Price: \$12,289,250.00

Contract Price after previous Change Order: N/A

Net Increase due to this Change Order: \$4,030.00

IV. CHANGE IN CONTRACT CALENDAR DAYS COMPLETION DATE

Original Contract Time 625

Contract Time after
previous Change Order N/A

Net (INCREASE)
due to this Change Order: To be determined

New Contract Time including
this Change Order 625

It is understood and agreed that, unless expressly so stated above, the work herein authorized will not extend the time for the completion of the contract.

This work is to be performed in accordance with the terms of the contract and original plans and specifications, except as herein modified. It is understood and agreed that this order shall be deemed executory only to the extent of moneys available and no liability shall be incurred by the State beyond the moneys available for the purpose.

APPROVALS

Contractor (Print) Sevenson Environmental Services, Inc.

(Sign) Title: Vice President

Date: _____

Engineer (Print) TAMS Consultants, Inc.

(Sign) Title: Resident Engineer

Date: _____

NYSDEC/Division of Hazardous Waste Remediation

(Print)

(Sign)

Title: Acting Division Director

Date:

NEW YORK STATE DEPARTMENT OF ENVIRONMENTAL CONSERVATION

(Print)

(Sign)

Title: Director, Div. of Fiscal Mgmt.

Date:

For NYS Dept. of Audit and Control Approval

Date:

chord10.17

New York State Department of Environmental Conservation
Division of Hazardous Waste and Remediation

CHANGE ORDER

Date of Issue: September 12, 1989

Change Order No.:

Change Order Amount:

Contract No.: D-001939

Project Name: Black and Bergholtz Creek Remediation,
Love Canal, Niagara County

NYSDEC Project No.: Site Number 9-32-020

Contractor's Name: Severson Environmental Services, Inc.

I. DESCRIPTION OF CHANGE

The modifications include deletion of the construction demolition debris (CDD) cell, addition of an internal berm in the DCF cell to subdivide the cell into two subareas identified as Subarea A and B and installation of an interim valve in the leachate transfer system from Subarea A.

DRAWINGS

Contract Drawing No. 207 (12/87)

Revised Contract Drawing No. 207A (7/29/89)

Revised Contract Drawing No. 207B (7/29/89)

SPECIFICATION

All work performed under this change order shall be conducted in accordance with the contract specifications and as ordered by the Engineer.

PAYMENT

Payment for the work as described above will be made on the basis of "estimate of actual cost of labor and materials plus overhead and profit, cost to be determined as the work progresses . . ." in accordance with Sub-article 11.4(c) of Section 071.0 - General Conditions.

II. REASON FOR CHANGE:

These modifications were made to accommodate changes to the Black and Bergholtz Creeks remediation plan which resulted from Occidental Chemical Corporation's agreement with the United States Environmental Protection Agency and NYSDEC.

The CDD Cell construction was stopped at the request of NYSDEC. At the time of the stop order, the CDD Cell's berm and lower clay liner were partially constructed. Therefore the following changes had to be made: (1) excavation of materials already in place and regrading of the area, (2) modifying the proposed toe drain along the east side of the CDD cell and (3) modifying the berm between the CDD cell and the DCF cell to the north.

NYSDEC also requested that an internal berm be designed to separate the DCF cell into two subareas which have been identified as Subareas A and B. Subarea A (northern end) of the DCF will be used to store the demolition debris initially intended to be placed in the CDD cell, and Subarea B (southern end) will be used as a containment area to temporarily hold contamination creek sediments at times with OCC is unable to accept waste.

The interim valve was necessary to limit leachate from Subarea B from backing into Subarea A during storm events or other times when the treatment plant is unable to process leachate at the same rate as it is generated.

III. CHANGE IN CONTRACT PRICE

Original Contract Price: \$12,289,250.00

Contract Price after previous Change Order: N/A

*Net Increase due to this Change Order: \$220,000.00

*Preliminary Estimate [See Payment Method]

<u>IV. CHANGE IN CONTRACT</u>	<u>CALENDAR DAYS</u>	<u>COMPLETION DATE</u>
Original Contract Time	625	
Contract Time after previous Change Order	N/A	
Net (INCREASE) due to this Change Order:	To be determined	
New Contract Time including this Change Order	625	

It is understood and agreed that, unless expressly so stated above, the work herein authorized will not extend the time for the completion of the contract.

This work is to be performed in accordance with the terms of the contract and original plans and specifications, except as herein modified. It is understood and agreed that this order shall be deemed executory only to the extent of moneys available and no liability shall be incurred by the State beyond the moneys available for the purpose.

APPROVALS

Contractor (Print) Sevenson Environmental Services, Inc.

(Sign) _____ Title: Vice President

Date: _____

Engineer (Print) TAMS Consultants, Inc.

(Sign) _____ Title: Resident Engineer

Date: _____

NYSDEC/Division of Hazardous Waste Remediation

(Print) _____

(Sign) _____ Title: Acting Division Director

Date: _____

NEW YORK STATE DEPARTMENT OF ENVIRONMENTAL CONSERVATION

(Print) _____

(Sign) _____

Title: Director, Div. of Fiscal Mgmt.

Date: _____

For NYS Dept. of Audit and Control Approval

Date: _____

chord912

New York State Department of Environmental Conservation
Division of Hazardous Waste and Remediation

CHANGE ORDER

Date of Issue: October 2, 1989

Change Order No.:

Change Order Amount:

Contract No.: D-001939

Project Name: Black and Bergholtz Creek Remediation,
Love Canal, Niagara County

NYSDEC Project No.: Site Number 9-32-020

Contractor's Name: Severson Environmental Services, Inc.

I. DESCRIPTION OF CHANGE

This change shall be comprised of the work that was performed to install additional storm sewer pipe along the north bank of Bergholtz Creek at approximate baseline station 13+0. Fifteen lineal feet of 18 inch steel storm sewer pipe was installed by the Contractor.

DRAWINGS

N/A

SPECIFICATION

All work completed under this change order shall conform to the contract specifications and as ordered by the Engineer.

PAYMENT

Payment for the work as described above will be made on the basis of "acceptance of agreed unit prices based on estimated cost plus overhead and profit as applicable . . ." in accordance with sub-article 11.4(b) or Section 071.0 General Conditions.

II. REASON FOR CHANGE:

During the storm sewer cleaning operations, a situation was encountered that reached beyond the scope of the Contractor's work under the original contract. A storm sewer outfall was discovered to be inadequate in length to meet the existing creek bank at its

outfall. In order to resolve this situation, the Contractor was ordered to perform the work needed to alleviate the problem.

III. CHANGE IN CONTRACT PRICE

Original Contract Price: \$12,289,250.00

Contract Price after previous Change Order: N/A

Net Increase due to this Change Order: \$ 4200.00

IV. CHANGE IN CONTRACT CALENDAR DAYS COMPLETION DATE

Original Contract Time 625

Contract Time after
previous Change Order N/A

Net (INCREASE)
due to this Change Order: 0

New Contract Time including
this Change Order 625

It is understood and agreed that, unless expressly so stated above, the work herein authorized will not extend the time for the completion of the contract.

This work is to be performed in accordance with the terms of the contract and original plans and specifications, except as herein modified. It is understood and agreed that this order shall be deemed executory only to the extent of moneys available and no liability shall be incurred by the State beyond the moneys available for the purpose.

APPROVALS

Contractor (Print) Sevenson Environmental Services, Inc.

(Sign) Title: Vice President

Date: _____

Engineer (Print) TAMS Consultants, Inc.

(Sign) _____ Title: Resident Engineer

Date: _____

NYSDEC/Division of Hazardous Waste Remediation

(Print) _____

(Sign) _____ Title: Acting Division Director

Date: _____

NEW YORK STATE DEPARTMENT OF ENVIRONMENTAL CONSERVATION

(Print) _____

(Sign) _____ Title: Director, Div. of Fiscal Mgmt.

Date: _____

For NYS Dept. of Audit and Control Approval

Date: _____

chord10.02

New York State Department of Environmental Conservation
Wolf Road, Albany, New York 12233

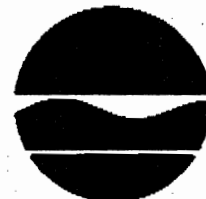

Thomas C. Jorling
Commissioner

NEW YORK STATE DEPARTMENT OF ENVIRONMENTAL CONSERVATION
DIVISION OF HAZARDOUS WASTE REMEDIATION

ORDER ON CONTRACT

Change Order No.: 20

Change Order Amount: \$199,927.98

Contract No.: D001939

Project Name: Black and Bergholtz Creeks Remediation
Love Canal Site, Niagara County, Niagara Falls, New York

NYSDEC Site Number: 9-32-020

Contractor's Name: Severson Environmental Services, Inc.

I. DESCRIPTION OF CHANGE

This change order reconciles the difference between the original costs of previously approved change order no.'s 1, 5, 10, 11, 12, 13, 14, 18, 19 and 21 and the costs accepted by the NYSDEC, which were compiled from the actual work reports. Also included under this change order is the additional work and associated costs required for the following seven items:

- A. Reimbursement to Severson Environmental Services, Inc. (SES) of the costs associated with the installation of the traffic control signs at the intersection of 91st Street and Cayuga Drive.
- B. Additional work involving restoration requirements under a Temporary Use and Occupancy Agreement (TUO) at the Stockings' property located at 1121 91st Street.
- C. Additional work required for the modifications to the railings at the 93rd Street Pedestrian Bridge.
- D. Partial reimbursement to SES of the deduction from pay estimate no. 21 for the costs incurred by the NYSDEC for cleaning pump chamber (PC) 3A.
- E. NYSDEC credit for the cost of 4-1/2 rolls of geotextile SES removed from the site and used on another contract.
- F. Property fence restoration for the Berard property.
- G. Reimbursement to SES of the costs to dispose of the crib wall material from Bergholtz Creek.

The costs stated herein represent the actual costs claimed as reviewed and approved by TAMS and accepted by the NYSDEC.

Change Order No. 20, B & B Creeks Remediation Contract No. D001939

Drawings

N/A

Specification

All work completed under this change order shall conform to the contract specifications and as ordered by the Engineer.

Payment

Payment for the work as described above will be made by the following basis:

1. For the reconciliation of change orders 1, 5, 10, 11, 12, 13, 14, 18, 19, and 21, payment will be made on the basis of actual cost of labor and materials plus overhead and profit as determined from the contractor's extra work reports reviewed and approved by TAMS and accepted by the NYSDEC.
2. For items A., D., and G., described above, payment will be made on the basis of the decision rendered by the NYSDEC concerning SES's appeals (see Attachments B, F and I respectively).
3. For item B. as described above, payment will be made on the basis of:
 - a. actual cost of labor and materials plus overhead and profit as determined from the contractor's extra work reports reviewed and approved by TAMS and accepted by the NYSDEC (see Attachment C for this cost) and,
 - b. lump sum quote submitted by the contractor, reviewed and approved by TAMS and accepted by the NYSDEC (see Attachment D for this quote).
4. For items C. and F., described above, payment will be made on the basis of a lump sum quote submitted by the contractor, reviewed and approved by TAMS and accepted by the NYSDEC (see Attachments E and H respectively).
5. For item E., described above, payment will be made on the basis of the actual cost to the NYSDEC for the material as charged by the contractor in their pay estimate (see Attachment G).

II. REASON FOR CHANGE

Final costs for the change orders based on time and materials, as accepted by the NYSDEC project manager, differed from the approved estimated costs. For change order numbers 5, 10, 11, 12, 13, 18, 19 and 21, accepted labor and material costs were less than the approved change order amounts. For change order numbers 1 and 14, accepted labor and material costs were greater than the approved change order amounts. The scope of work for these change orders was unchanged.

Change Order No. 20, B & B Creeks Remediation Contract No. D001939

The following reasons and descriptions are separated into three (3) groups for better clarification of the purpose of this change order:

1. Contract cost adjustment for final (previously approved) change order costs, accepted by the NYSDEC project manager, ending up under the approved change order amount. This group of previously approved change orders includes nos. 5, 10, 11, 12, 13, 18, 19 and 21. Because of the fact that these change orders were performed on a "time and materials" (T&M) basis, the final cost of the change order could only be estimated. In this case the accepted cost of all of these change orders came in under the estimated cost. See Attachment A for the listing of the costs differences for these change orders.
2. Contract cost adjustment for final (previously approved) change order costs ending up over the approved change order amount. This group of previously approved change orders includes nos. 1 and 14. Again due to the nature of the change order type (T&M), the final costs could only be estimated at the time of the original submission.

Change order no. 1 involved the work required by the General Contractor to install the force main from the Decontamination/Drum Storage Facility (DDSF) to the Love Canal Leachate Treatment Facility (LCLTF) after the prime contract for the DDSF was split into three prime contracts to satisfy Wick's Law requirements. Due to extremely difficult working requirements involving construction of the force main containment system as well as delays due to wet conditions and dewatering requirements, unforeseen by both the contractor and the engineering consultant responsible for the preparation of the cost estimate, material and labor costs overran the original estimate.

Change order no. 14 involved work to satisfy a required design change to the construction of the concrete crib wall in Bergholtz Creek. As work progressed in excavating the creek bed for preparation of the construction of a structural foundation for the crib wall, costs involved in unforeseen dewatering requirements and additional sheet pile installation requirements resulted in cost overruns in both labor and materials costs.

See Attachment A for the listing of the costs differences for these change orders.

3. A. Reimbursement to SES of the costs associated with the installation of the traffic control signs at the intersection of 91st Street and Cayuga Drive. On February 23, 1990, in a letter from Michael J. O'Toole, Jr. (Attachment B), the DEC upheld SES's appeal for reimbursement of the costs associated with this work. This change order will provide for that reimbursement (\$405.00).
- B. Additional work involving restoration requirements under a Temporary Use and Occupancy Agreement (TUO) at Mr. Stockings' property. Prior to the commencement of this contract, the DEC had negotiated with numerous property owners along Bergholtz

Change Order No. 20, B & B Creeks Remediation Contract No. D001939

Creek for the right of access on their property for purposes of completing the remediation project. To document the what was agreed to during the negotiations, between the property owner and the DEC, a TUO was prepared and signed by both parties. The work agreed to under the TUO for restoration of the property was not made part of the contract with SES but instead was considered change order work. SES performed restoration work (at a cost of \$1,141.00) for Mr. Stockings' property as previously agreed to in a signed TUO. SES is entitled to reimbursement of this cost. See Attachments C and D for SES's costs for this work.

- C. Additional work required for the railings at the Pedestrian Bridge. During a final inspection walk through with the City of Niagara Falls, the City requested a change to the construction of the hand railings due to the presence of a large gap between the hand railing and the bridge railing. The City requested, with the DEC's concurrence, that the gap be closed in order to prevent the potential of children slipping through the gap and falling into the Bergholtz Creek. SES has provided a lump sum quote, in the amount of \$1,250.00, to perform the work. See Attachment E for this quote.
- D. Partial reimbursement to SES of the deduction from pay estimate no. 21 for the costs incurred by the NYSDEC for cleaning pump chamber (PC) 3A. On July 10, 1990, in a letter from Michael J. O'Toole, Jr. (Attachment F), the DEC upheld SES's appeal for reimbursement of a portion of the costs associated with this work. This change order will provide for that partial reimbursement (\$1,793.28).
- E. NYSDEC credit for the cost of 4-1/2 rolls of geotextile SES removed from the site and used on another contract. As a result of the elimination of a portion of the DCF cell due to Occidental Chemical Company's intervention, excess geotextile material was stockpiled on-site. Under a separate remediation contract for the Charles Gibson site (site no. 9-32-063) SES was required to install the same material as was used under this contract. Upon request, SES was allowed to remove the stockpiled geotextile and use it at the Gibson site. SES agreed to credit the NYSDEC \$600.00 for the material. This change order includes this credit in the net cost. See Attachment G for the identification of this credit.
- F. Property fence restoration for Mr. Berard. Mr. Berard's property borders the Bergholtz Creek and a portion of the property adjacent to the creek was utilized for the remediation efforts. Final property restoration efforts included additional work to repair Mr. Berard's fence. This work is considered beyond the scope of the contract restoration requirements and includes replacement of the fence fabric, top rail and installation of a concrete end post encasement. The work is necessary to satisfy Mr. Berard's disputed claims over what was existing prior to the commencement of creek excavation and Mr. Berard's claims of damages to his property by the contractor. See Attachment H for this cost quote in the amount of \$1,150.00.

- G. Reimbursement to SES of the costs to dispose of the crib wall material from Bergholtz Creek. On May 21, 1990, in a letter from Michael J. O'Toole, Jr. (Attachment I), the DEC upheld SES's appeal for reimbursement of the costs SES incurred to dispose of existing wooden retaining wall material removed along the Bergholtz Creek during the installation of the new concrete crib wall. This change order will reimburse SES for their cost (\$6,357.00).

III. CHANGE IN CONTRACT PRICE

Original Contract Price:	\$12,289,250.00
Contract Price after previous Change Order:	\$13,043,874.25
Net Increase due to this Change Order:	\$ 199,927.98
New Contract Price:	\$13,243,802.23

IV. CHANGE IN CONTRACT CALENDAR DAYS COMPLETION DATE

Original Contract Time	625 Days	December 12, 1989
Contract Time after previous Change Order	810 Days	June 15, 1990
Net Increase due to this Change Order	0 Days	June 15, 1990
New Contract Time	810 Days	June 15, 1990

It is understood and agreed that, unless expressly so stated above, the work herein authorized will not extend the time for the completion of the contract.

This work is to be performed in accordance with the terms of the contract and original plans and specifications, except as herein modified. It is understood and agreed that this order shall be deemed executory only to the extent of moneys available and no liability shall be incurred by the State beyond the moneys available for the purpose.

APPROVALS

Contractor (Print): SEVENSON ENVIRONMENTAL SERVICES, INC.

(Sign) [Signature] Title: EXEC. VICE - PRESIDENT

Date: 8/17/90

Engineer (Print): _____

(Sign) _____ Title: _____

Date: _____

NYSDEC/Division of Hazardous Waste Remediation

(Print) Michael J. O'Toole, Jr.

(Sign) _____ Title: _____

Date: _____

NEW YORK STATE DEPARTMENT OF ENVIRONMENTAL CONSERVATION

(Print) _____

(Sign) _____ Title: Dir. Div. of Fiscal Mgmt.

Date: _____

For NYS Dept. of Audit and Control Approval

Date: _____

Attachments

Change Order No. 20, B & B Creeks Remediation Contract No. D001939

LIST OF ATTACHMENTS

<u>Attachment</u>	<u>Description</u>
A	Listing of the differences between the approved amount and accepted costs of all applicable, previously approved change orders and additional costs/credits to be included under change order no. 20.
B	Response letter from Michael J. O'Toole, Director, Division of Hazardous Waste Remediation (MJO) to Severson Environmental Services (SES), dated February 23, 1990, regarding the appeal for the costs to install traffic control signs.
C	SES's extra work report(s) for Stockings' TUO requirements.
D	SES's cost quote for Stockings' TUO requirements.
E	SES's cost quote for modifications to railings at the 93rd Street pedestrian bridge.
F	Response letter from MJO to SES, dated July 10, 1990, regarding the appeal for deduction of NYSDEC costs for PC 3A cleaning.
G	SES's invoice showing their cost (passed on to the NYSDEC) for geotextile.
H	SES's cost quote for Mr. Berard's fence restoration.
I	Response letter from MJO to SES, dated May 21, 1990, regarding appeal for disposal costs of wooden retaining wall material.

ATTACHMENT A

09-Aug-90

Change Order No. 20
 Mack and Bergholtz Creeks Remediation Contract No. D001939
 Svenson Environmental Services, Inc.

C.O. No.	Description	Approved Amount	Accepted Cost	Difference
1	DDSF General/Electric	\$239,407.00	\$385,256.00	\$145,849.00
5	Telescoping Wells	\$44,124.00	\$28,694.54	(\$15,429.46)
10	DDSF Location, Catch Basin, Dewatering	\$26,145.00	\$19,427.00	(\$6,718.00)
11	Primary Sheetpile Cofferdam	\$25,000.00	\$18,145.00	(\$6,855.00)
12	Utility Conflict	\$15,000.00	\$9,598.00	(\$5,402.00)
13	Remediation of Reach "C"	\$20,088.00	\$12,546.00	(\$7,542.00)
14	Cribwall Foundation Replacement	\$57,237.00	\$148,816.00	\$91,579.00
18	DCF Modifications	\$220,000.00	\$213,312.00	(\$6,688.00)
	94th Street Storm Sewer Extension	\$4,200.00	\$3,873.00	(\$327.00)
21	100th Street Stockpile	\$19,377.00	\$19,342.16	(\$34.84)
N/A	SES Appeal Traffic Signs	N/A	\$405.00	\$405.00
N/A	Stocking's TUO Requirements (\$183+\$958)	N/A	\$1,141.00	\$1,141.00
N/A	Pedistrian Bridge Railings	N/A	\$1,250.00	\$1,250.00
N/A	SES Appeal Cleaning PC 3A	N/A	\$1,793.28 (See Note 1)	\$1,793.28
N/A	NYSDEC Credit 4-1/2 Rolls of Geotextile	N/A	(\$600.00)	(\$600.00)
N/A	Fence Work at Berard's	N/A	\$1,150.00	\$1,150.00
N/A	SES Appeal Crib Wall Mat'l Disposal	N/A	\$6,357.00	\$6,357.00
	TOTALS			\$199,927.98

NOTES:

1. Partial reimbursement of \$2,800.00 deducted under pymt no. 21

New York State Department of Environmental Conservation
Division of Hazardous Waste and Remediation

CHANGE ORDER

Date of Issue: October 16, 1989

Change Order No.:

Change Order Amount:

Contract No.: D-001939

Project Name: Black and Bergholtz Creek Remediation,
Love Canal, Niagara County

NYSDEC Project No.: Site Number 9-32-020

Contractor's Name: Severson Environmental Services, Inc.

I. DESCRIPTION OF CHANGE

Uniform grading and shaping of general excavation stockpile at designated 100th Street Spoil Area of DCF construction phase of contract.

DRAWINGS

Contract Drawing No. 103 and Grading Sketch dated 10/16/89.

SPECIFICATION

All work completed under this change order shall conform to the contract specifications and as ordered by the Engineer.

PAYMENT

Payment for the work as described above will be made on the basis of "estimate of actual cost of labor and materials plus overhead and profit, cost to be determined as the work progresses . . ." in accordance with Sub-article 11.4(c) of Section 071.0 - General Conditions.

II. REASON FOR CHANGE:

Deemed necessary by the NYSDEC from an environmental and aesthetic standpoint for general restoration of the 100th Street Spoil Area of the Love Canal Site.

III. CHANGE IN CONTRACT PRICE

Original Contract Price: \$12,289,250.00

Contract Price after previous Change Order: N/A

*Net Increase due to this Change Order: \$ 19,377.00

*Preliminary Estimate [See Payment Method]

IV. CHANGE IN CONTRACT CALENDAR DAYS COMPLETION DATE

Original Contract Time 625

Contract Time after
previous Change Order N/A

Net (INCREASE)
due to this Change Order: To be determined

New Contract Time including
this Change Order 625

It is understood and agreed that, unless expressly so stated above, the work herein authorized will not extend the time for the completion of the contract.

This work is to be performed in accordance with the terms of the contract and original plans and specifications, except as herein modified. It is understood and agreed that this order shall be deemed executory only to the extent of moneys available and no liability shall be incurred by the State beyond the moneys available for the purpose.

APPROVALS

Contractor (Print) Sevenson Environmental Services, Inc.

(Sign) Title: Vice President

Date: _____

Engineer (Print) TAMS Consultants, Inc.

(Sign) Title: Resident Engineer

Date: _____

NYSDEC/Division of Hazardous Waste Remediation

(Print)

(Sign) Title: Acting Division Director

Date: _____

NEW YORK STATE DEPARTMENT OF ENVIRONMENTAL CONSERVATION

(Print)

(Sign) Title: Director, Div. of Fiscal Mgmt.

Date: _____

For NYS Dept. of Audit and Control Approval

Date: _____

chord10.16a

NEW YORK STATE DEPARTMENT OF ENVIRONMENTAL CONSERVATION
DIVISION OF HAZARDOUS WASTE AND REMEDIATION

CHANGE ORDER

Date of Issue: October 10, 1990

Change Order No. 22

Change Order Amount: Credit: (-\$1700.16)

Contract No. : D-001939

Project Name: Black and Bergholtz Creek Remediation,
Love Canal, Niagara County

NYSDEC Project No: Site Number 9-32-020

Contractor's Name: Severson Environmental Services, Inc.

I. DESCRIPTION OF CHANGE

- a) Provide and install six (6) Roof Deflectors for exhaust fans curbs of DDSF building. [Debit Amount: \$1,848.00]
- b) Purchase by Contractor of 6,336 square feet of 80 mil HDPE Liner. Previously stockpiled on-site at the Love Canal PSA. [Credit Amount: \$3,548.16]
- c) Increase Contract completion by 138 days thus revising completion date from June 15, 1990 to November 1, 1990 at no additional cost.

DRAWINGS

- a) TAMS sketch dated 7-2-90.
- b) NA
- c) NA

SPECIFICATIONS

Contract specifications Part II and as Ordered BY Engineer.

PAYMENT

Payment for the work as described above will be made on the basis of "acceptance of agreed unit prices based on estimated cost plus overhead and profit as applicable . . ." in accordance with subarticle 11 4(b) or Section 071.0 General Conditions.

II. REASONS FOR CHANGE:

- a) Necessary modification to roof flashing and drainage in order to facilitate positive roof drainage and prevent roof leaks.

- b) Agreed sale of excess material remaining at Love Canal Site, due to design modifications of the DCF cell. Excess 80 mil liner used at the Gibson Site [Site No. 9-32-063].
- c) Completion of work for this change order.

III. CHANGE IN CONTACT PRICE

Original Contract Price: \$12,289,250.00

Contract Price after previous Change Order (Change order No. 20): \$ 13,242,802.23

Net Decrease due to this Change Order: \$1,700.16

New Contract Price: \$ 13,242,102.07

IV. CHANGE IN CONTRACT CALENDAR DAYS COMPLETION DATE

Original Contract Time 625 12-16-89

Contract Time after
previous Change Order 810 6-19-90

Net (INCREASE) due to
this Change Order: 138

New Contract Time
including this Change
Order 948 11-04-90

This work is to be performed in accordance with the terms of the contract and original plans and specifications, except as herein modified. It is understood and agreed that this order shall be deemed executory only to the extent of moneys available and no liability shall be incurred by the State beyond the moneys available for the purpose.

APPROVALS

Contractor (Print) Sevenson Environmental Services, Inc.

(Sign)  Title: Vice President

Date: 11/1/90

Engineer (Print) TAMS Consultants, Inc.

(Sign) D.W. Melanson Title: Resident Engineer

Date: 11/5/90

NYSDEC/DIVISION of Hazardous Waste Remediation

(Print) _____

(Sign) _____ Title: Acting Division Director

Date: _____

NEW YORK STATE DEPARTMENT OF ENVIRONMENTAL CONSERVATION

(Print) _____

(Sign) _____ Title: Director, Div. Fiscal Mgmt.

Date: _____

For NYS Dept. of Audit and Control Approval
Date: _____

TAMS

Job No. 5016

Project BLACK & BERGHOLTZ CREEKS REMEDIATION

Subject DDSF BLDG ROOF EXHAUST FAU CURB

CRICKET / DEFLECTOR DETAIL

Sheet 1 of 1

Date 7-2-90

By DWM

Ch'k. by _____

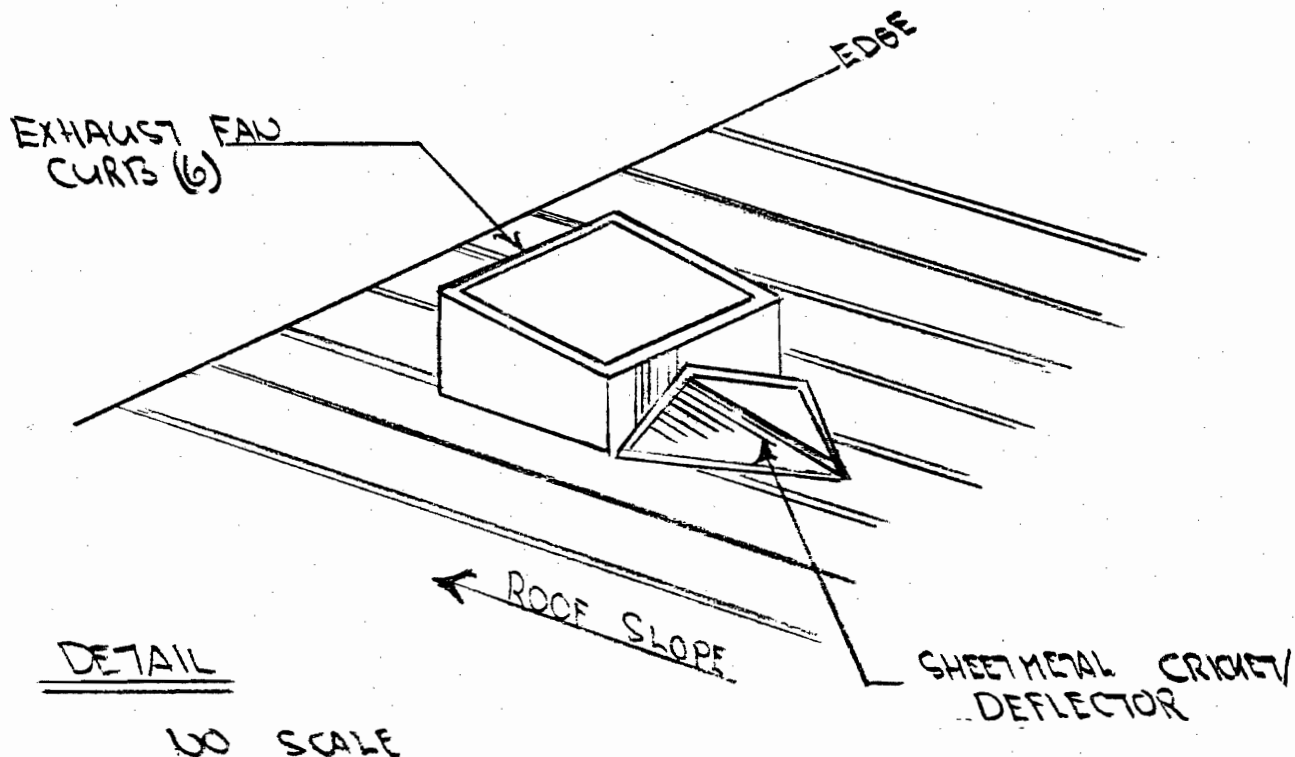

PROPOSAL:

- INSTALLATION OF A SHEET METAL CRICKET / DEFLECTOR ON HIGH SIDE OF EXHAUST FAU CURB TO PREVENT WATER FROM 'POUNDING'. [SIX LOCATIONS]
- ALTERNATE PROPOSAL - USE OF ASPHALT OR ROOF CEMENT BUILT-UP ON CURB TO PREVENT POUNDING AT FAU AREA OF CURB.

6.3 CLAIMS