

The electronic version of this file/report should have the file name:

Report. HW. 932052. 1999-03-29. 1998-1999 - GW -

Monitoring - Summary. pdf

Type of document . Site Number . Year-Month . File Year-Year or Report name . pdf

---

\_\_\_\_\_ . File \_\_\_\_\_ . pdf

example: letter . Year-Month . File Year-Year . pdf

---

\_\_\_\_\_ . pdf

example: report . Site Number . Year-Month . Report Name . pdf

Project Site numbers will be preceded by the following:

Municipal Brownfields - B

Superfund - HW

Spills - SP

ERP - E

VCP - V

BCP - C

Handwritten text, possibly a date or initials, oriented vertically on the left side of the page.

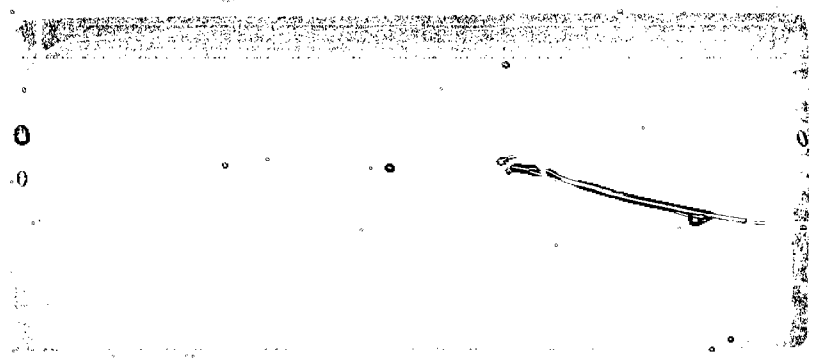

**Golder Associates Inc.**

2221 Niagara Falls Boulevard, Suite 9  
Niagara Falls, NY USA 14304  
Telephone (716) 731-1560  
Fax (716) 731-1652



RECEIVED

APR 01 1999

NYSDEC - REG. 9  
FOIL  
REL UNREL

REPORT ON

1998-1999 ANNUAL SUMMARY AND  
SYSTEM PERFORMANCE  
OFF-SITE AND ON-SITE GROUNDWATER  
EXTRACTION SYSTEMS  
FORMER TEXTRON INC.  
WHEATFIELD, NEW YORK FACILITY

Submitted to:

Textron Inc.  
40 Westminster Street  
Providence, Rhode Island, 02903-6028

DISTRIBUTION:

8 Copies - Ms. Leslie Alden; Textron Inc.; Providence, Rhode Island  
1 Copy - Golder Associates Inc.; Buffalo, New York

March 1999

973-9158

**Golder Associates Inc.**

2221 Niagara Falls Boulevard, Suite 9  
Niagara Falls, NY USA 14304  
Telephone (716) 731-1560  
Fax (716) 731-1652



March 29, 1999

973-9158

Textron Inc.  
40 Westminster Street  
Providence, Rhode Island, 02903-6028

Attention: Ms. Leslie Alden

RE: REPORT ON 1998-1999 ANNUAL SUMMARY AND SYSTEM  
PERFORMANCE, OFF-SITE AND ON-SITE GROUNDWATER EXTRACTION  
SYSTEMS, FORMER TEXTRON INC., WHEATFIELD, NEW YORK  
FACILITY

Dear Ms. Alden:

Golder Associates Inc. (Golder) is pleased to submit this report on the 1998-1999 Annual Summary and System Performance for the Off-Site and On-Site Groundwater Extraction Systems located at the former Textron Inc.'s (Textron's) Wheatfield facility in Wheatfield, New York. This report is submitted in accordance with Textron's New York State Department of Environmental Conservation (NYSDEC) Title 6 New York Code of Rules and Regulations (6NYCRR) Part 373 Post-Closure Permit, effective September 24, 1998 (Permit No. 9-2940-00001/000079).

Golder appreciates the opportunity to provide continuing professional engineering services to Textron. If you have any questions regarding this report, please do not hesitate to call.

Very truly yours,

GOLDER ASSOCIATES INC.

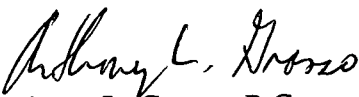
  
Anthony L. Grasso, P.G.  
Project Director/Associate

ALG:dml

Attachments

F/N: C:\Common\Projects\973-9158\Reports\98-99ANN\STHANN.DOC



TABLE OF CONTENTS

Cover Letter

Table of Contents

i

<u>SECTION</u>	<u>PAGE</u>
1. INTRODUCTION .....	1
2. BACKGROUND .....	2
3. SUMMARY OF GROUNDWATER MONITORING.....	3
3.1 General.....	3
3.2 Chemical Monitoring.....	3
3.3 Hydraulic Monitoring.....	5
3.3.1 General.....	5
3.3.2 Off-Site System.....	5
3.3.3 On-Site System .....	6
3.4 Routine Operations and Maintenance of Monitoring Points.....	8
4. SUMMARY OF SYSTEM OPERATIONS .....	10
4.1 Off-Site System .....	10
4.2 On-Site System.....	10
5. RECOMMENDATIONS FOR FUTURE GROUNDWATER MONITORING AND SYSTEM OPERATIONS .....	12
6. SUMMARY.....	13
REFERENCES.....	14

In Order  
Following  
Page 14

- TABLE 1 - Monitoring Points Included in the On-Site and Off-Site Effectiveness Monitoring Program
- TABLE 2 - Summary of Groundwater Analytical Data (Detected Compounds Only), April 1998 Semi-Annual Monitoring Event
- TABLE 3 - Summary of Groundwater Analytical Data (Detected Compounds Only), October 1998 Annual Monitoring Event
- TABLE 4 - Summary of Hydraulic Monitoring, April 1998 Semi-Annual Monitoring Event
- TABLE 5 - Summary of Hydraulic Monitoring Data, July 1998 Quarterly Monitoring Event

TABLE OF CONTENTS  
(Continued)

TABLE 6	-	Summary of Hydraulic Monitoring Data, October 1998 Annual Monitoring Event
TABLE 7	-	Summary of Hydraulic Monitoring Data, January 1999 Quarterly Hydraulic Monitoring Event
TABLE 8	-	Summary of Vertical Hydraulic Gradients
TABLE 9	-	Summary of Operations and Maintenance of Monitoring Points
FIGURE 1	-	Sample Locations
FIGURE 2	-	MW 89-15(1) TVOC Concentrations versus Time
FIGURE 3	-	MW 87-20(1) TVOC Concentrations versus Time
FIGURE 4	-	EW-4 TVOC Concentrations versus Time
FIGURE 5	-	Groundwater Elevation Contour Map Zone 1 Bedrock - October 1998
FIGURE 6	-	On-Site Groundwater Elevation Contour Map Zone 1 Bedrock - October 1998
FIGURE 7	-	Groundwater Elevation Contour Map Zone 1 Bedrock - April 1998
FIGURE 8	-	On-Site Groundwater Elevation Contour Map Zone 1 Bedrock - April 1998
FIGURE 9	-	Groundwater Elevation Contour Map Zone 1 Bedrock - July 1998
FIGURE 10	-	On-Site Groundwater Elevation Contour Map Zone 1 Bedrock - July 1998
FIGURE 11	-	Groundwater Elevation Contour Map Zone 1 Bedrock - January 1999
FIGURE 12	-	On-Site Groundwater Elevation Contour Map Zone 1 Bedrock - January 1999
FIGURE 13	-	Groundwater Elevation Contour Map Zone 3 Bedrock - October 1998
APPENDIX A	-	Analytical Sampling Results

## 1. INTRODUCTION

This report represents the annual summary and system performance report for the Off-Site Groundwater Extraction System and the On-Site Groundwater Extraction System (Off-Site System and On-Site System, respectively) located at the former Textron Inc. (Textron) Wheatfield facility located at 2221 Niagara Falls Boulevard in Wheatfield, New York, for the 12-month period March 1998 through February 1999. This report is submitted in accordance with Textron's New York State Department of Environmental Conservation (NYSDEC) Title 6 New York Code of Rules and Regulations (6NYCRR) Part 373 Post Closure Permit, September 24, 1998 (Permit No. 9-2940-00001/000079). Included herein is a summary of the previous twelve months of operation including groundwater quality results, groundwater hydraulic monitoring results, and system operation information. In addition, this report presents proposed changes to Textron's current groundwater monitoring program (GMP) and recommendations for future operations for the Off-Site System (based on the first six years of operation) and the On-Site System (based on the first four years of operation).

## 2. BACKGROUND

The Off-Site System consists of six Zone 1 bedrock groundwater extraction wells (EW-1 through EW-6), connected by a subsurface double-containment pipeline that discharges the extracted groundwater to the Niagara County Sewer District (NCSD) Publicly Owned Treatment Works (POTW). Figure 1 presents a site layout showing the locations of the extraction wells and the groundwater monitoring points. The Off-Site System has been operating since March 1993. Extraction well EW-1 was taken out of service during system start-up in March 1993, based on the hydraulic response observed during system start-up. EW-6 was taken off-line on April 11, 1996 in an attempt to reduce the constituent concentration at the southern boundary of the dissolved phase plume in the area of EW-6. The cessation of pumping at EW-6 has allowed EW-5 to draw the dissolved phase plume boundary (as of October 1998, just to the south of EW-6) to the north toward EW-5.

The On-Site System consists of seven Zone 1 bedrock groundwater extraction wells (EW-7, EW-8, EW-13, and DW-9 through DW-12) connected by a subsurface double-containment pipeline that delivers the extracted groundwater to the On-Site Treatment Plant. At the Treatment Plant, the water is stripped of volatile organic compounds (VOCs), the VOCs thermally destroyed (until June 2, 1998 when the thermal oxidizer was bypassed and the VOCs discharged to the atmosphere under a NYSDEC approved air permit) and the water ultimately discharged to the Walmore Road storm sewer. Figure 1 presents a site layout showing the locations of the extraction wells and the groundwater monitoring points. Construction of the system was initiated on September 20, 1993, and was substantially completed in late 1994. Start-up of the system began in February 1995. DW-9 was taken off-line on May 26, 1998 in order to focus remedial efforts on the southern facility property line near wells EW-7 and EW-8. In order to form a more robust hydraulic barrier between wells EW-7 and EW-8, extraction well EW-13 was added to the system approximately midway between these wells and was activated on September 25, 1998.

### 3. SUMMARY OF GROUNDWATER MONITORING

#### 3.1 General

Groundwater quality and hydraulic monitoring of the Off-Site and On-Site Systems were performed pursuant to Textron's GMP (Golder, February 1993 and the new revision Golder, October 1998a) and the data for the past year were presented in individual Monitoring Event Reports (Golder, July 1998, October 1998b, January 1999, and March 1999). Groundwater quality monitoring was conducted in April 1998 and October 1998. Hydraulic monitoring was conducted on a quarterly basis, in April 1998, July 1998, October 1998, and January 1999, with the April and October events corresponding with the two groundwater quality monitoring events in April and October. As detailed in the GMP, groundwater quality sampling is currently scheduled to be conducted on an annual basis (each October), whereas hydraulic monitoring will continue to be performed quarterly.

A summary of the operations associated with the Off-Site System during each quarter, including a discussion of the groundwater quality and hydraulic monitoring data collected during the representative quarter, is presented in detail in each of the aforementioned Quarterly Reports. The following sections present some general trends that are noted in the data collection during the past year.

#### 3.2 Chemical Monitoring

Table 1 presents the monitoring points included in Textron's GMP for the most recent sampling event (October 1998); the monitoring locations are shown on Figure 1. Groundwater quality monitoring was conducted on a semi-annual basis (April 1998 and October 1998) with additional monitoring points included during the annual event (October 1998). These monitoring events include the analysis for USEPA Method 8260 VOCs only, for each monitoring point. Tables 2 and 3 present a summary of the detected compounds of the groundwater analytical data from the semi-annual and annual event, respectively. Appendix A presents a database of all analyzed compounds for the past four years for each monitoring point.

Continuing downward chemical trends have been observed in most monitoring wells and extraction wells, based on calculated total volatile organic compound (TVOC) concentrations. TVOC concentrations were calculated by summing the concentrations of all detected compounds for a sample. For the On-Site area, this downward trend in TVOC concentrations is well illustrated by the TVOC concentration versus time plot of analytical results from monitoring well 89-15(1) (located over the DNAPL plume), as shown on Figure 2. This apparent reduction of TVOC concentrations may be attributed to the pumping of the Zone 1 aquifer by the On-Site System. Notable over the last two years is a decrease in the rate of VOC reduction; this pattern is well known for pump and treat groundwater remediation systems as the mass of contaminants is reduced through extraction.

The downward trend in TVOC concentrations for an area between the On-Site and Off-Site Systems is shown by the TVOC concentration versus time plot of analytical results from monitoring well 87-20(1) (located north of the Off-Site System), as shown on Figure 3. Reductions of TVOC concentrations in this well may be attributed to the pumping of both the On-Site and Off-Site Systems.

Figure 4 presents the TVOC concentration versus time plot of analytical results from extraction well EW-4. This Off-Site extraction well displays a continuing downward trend in TVOC concentrations.

Figure 5 presents the approximate limit of the dissolved phase plume in the Zone 1 bedrock aquifer, based upon the groundwater quality monitoring data collected during the October 1998 annual monitoring event (Golder, January 1999). The extent of the dissolved phase plume in Zone 1 has remained relatively constant as compared to last year, as anticipated.

### 3.3 Hydraulic Monitoring

#### 3.3.1 General

Tables 4 through 7 present a quarterly summary of the past year's hydraulic monitoring data. Figures 5, 7, 9, and 11 present groundwater elevation contour maps for each quarter for both the On-Site and Off-Site area together while Figures 6, 8, 10, and 12 present more detailed quarterly groundwater elevation contour maps of just the On-Site area.

#### 3.3.2 Off-Site System

Groundwater equipotential maps of the Zone 1 bedrock aquifer in the vicinity of the On-Site and Off-Site Systems for all four quarters are presented on Figures 5, 7, 9, and 11. These maps show there is a consistent and significant overlap of the cone-of-depression and the contaminant plume in the off-site area, which is one of the design goals of the system. The hydraulic response to pumping of the Off-Site System has remained reasonably consistent since system startup in March 1993, although precipitation is shown to have a significant impact on the overall elevation of the cone-of-depression. Precipitation events tend to raise the elevation of all the wells in the off-site area. However, an inward hydraulic gradient toward the Off-Site System has always been observed.

Groundwater flow directions, as shown by the arrows on Figures 5, 7, 9, and 11, have remained relatively consistent within the developed cone-of-depression. The flow direction is generally towards the four pumping extraction wells (i.e. EW-2 through EW-5) of the Off-Site System. The horizontal hydraulic gradient in the area immediately north of the Off-Site System during October 1998 was approximately 0.007 feet/foot (ft/ft), as determined from water levels recorded in wells 87-20(1) and EW-2 in October 1998 (see Figure 5). This figure is in good agreement with the horizontal gradient between these two wells over the past several years and the gradient is exactly the same as last year (Golder, March 1998).

The flow rate, or average linear velocity of groundwater, can be calculated from hydraulic gradient data. To calculate this flow rate ( $V_s$ ), the average Zone 1 hydraulic conductivity ( $K$ ) of  $2 \times 10^{-3}$  centimeters per second (cm/sec), an effective porosity ( $n_e$ ) value of 3-percent, as presented in the Resource Conservation and Recovery Act (RCRA) Facility Investigation (RFI) for the Textron facility (Golder, June 1991), and the calculated hydraulic gradient ( $i$ ) as recorded during October 1998 were used. The formula is:

$$V_s = -K/n_e \times i$$

The flow rate in the area immediately north of the Off-Site System during October 1998 was approximately 1.32 feet per day (ft/day), based on the hydraulic gradient of 0.007 ft/ft. The flow rates are comparable from year to year.

### 3.3.3 On-Site System

The hydraulic response of the On-Site System through this year has reached the design expectations of establishing a zone of groundwater capture over the DNAPL plume; establishing a groundwater zone of capture along the southern property boundary of the Textron facility; maintaining an upward gradient between the Zone 3 and Zone 1 aquifers; and maintaining a downward gradient between the overburden and the Zone 1 aquifer.

A groundwater capture zone has been created by operation of the On-Site System, in the Zone 1 aquifer, over the DNAPL plume. An examination of the Zone 1 equipotential maps for the quarterly monitoring (Figures 6, 8, 10, and 12) illustrate that the operation of the On-Site System is producing a hydraulic capture zone in Zone 1 over essentially all of the DNAPL plume. As shown on Figures 6, 8, 10, and 12, for each quarterly monitoring event groundwater flowing through Zone 1 over the area of the DNAPL plume is not migrating off-site. In addition, groundwater flowing through the on-site area that is not captured by extraction wells DW-10 through DW-12 (adjacent to the DNAPL plume) is subsequently captured by the On-Site extraction wells EW-7, EW-8, and EW-13.



The quarterly monitoring events in April 1998, October 1998, and January 1999, (see Figures 6, 8, and 12), show a groundwater capture zone developed in Zone 1 along the southern boundary of the on-site area south of Niagara Falls Boulevard, however, prior to the installation of EW-13 in September of 1998, it did not extend entirely across the area between EW-7 and EW-8. During the July 1998 quarterly monitoring event (see Figure 10), EW-7 and EW-8 were off-line for the construction of EW-13 and no capture zone was observed. Following the activation of EW-13, a complete capture zone along the southern boundary of the on-site area has been observed in both subsequent hydraulic monitoring events (Figure 6, October 1998 and Figure 12, January 1999).

The horizontal hydraulic gradient in the Zone 1 bedrock at the on-site area has been measured from two locations in October 1998, as determined from water levels recorded between monitoring well 87-02(1) and extraction well DW-12; and between monitoring well 87-01(1) and extraction well EW-8 (See Figure 6). A horizontal hydraulic gradient of 0.015 ft/ft was calculated between wells 87-02(1) and DW-12 and a horizontal hydraulic gradient of 0.025 ft/ft was calculated between wells 87-01(1) and EW-8. The on-site groundwater flow rate, using a hydraulic conductivity value of  $2 \times 10^{-3}$  cm/sec and an effective porosity value of 3-percent (the same parameters as used for the off-site area), is 2.8 ft/day, based on a gradient of 0.015 ft/ft between 87-02(1) and DW-12, and 4.7 ft/day, based on a gradient of 0.025 ft/ft between 87-01(1) and EW-8.

Data from every quarter (presented in their respective quarterly reports) indicate that the desired upward gradients, between Zones 3 and 1, and downward gradients, between the overburden and Zone 1, are present in every well cluster measured with the exception of some instances during the January 1999 monitoring event. Because of a significant snow melt event occurring during that time, upward gradients between overburden and Zone 1 were noted in well pairs 87-15, 87-17, and 87-21.

Table 8 presents a summary of vertical hydraulic gradients between Zones 1 and 3 based on the past year's hydraulic monitoring data. The data indicate that the hydraulic gradients range from -0.011 to 0.79 ft/ft; in every case but one, the flow direction is upwards from

Zone 3 to Zone 1, which is the desired direction. The downward vertical gradient noted in January 1998 in well pair 87-15, as discussed in the quarterly report and also above, was likely caused by the significant snow melt event occurring during that time.

Figure 13 presents an on-site groundwater elevation contour map for the Zone 3 bedrock aquifer as measured in October 1998. It indicates that groundwater flow in the Zone 3 aquifer is generally in a southeasterly direction, which is similar to its flow direction prior to the On-Site System's operation.

### **3.4 Routine Operations and Maintenance of Monitoring Points**

During each monitoring event, personnel performed a standard general operations and maintenance (O&M) check of each well sampled. The following is a compilation of the results of the O&M check and activity completed, per monitoring event. Table 9 summarizes the following information:

#### April 1998

No deficiencies were noted.

O&M activities from the previous quarter, performed prior to the April 1998 monitoring event, included the resurvey of repaired well 89-03(1) and a riser elevation check of well 87-04(0) which may have suffered frost heave. No frost heave was evident.

#### July 1998

No deficiencies were noted.

October 1998

During the October 1998 O&M check, the following problems were noted:

- Monitoring well 89-22(0) had its lock hammered off by vandals; and
- Monitoring well 89-22(1) had its lock damaged by vandals.

No other damage to the wells was noted. The locks were replaced the day the damage was discovered, on October 26, 1998.

January 1999

No deficiencies were noted.

## 4. SUMMARY OF SYSTEM OPERATIONS

### 4.1 Off-Site System

There were no operational changes made to the Off-Site System during the past year. No unscheduled down time was noted for the Off-Site System this year.

Specific pump flow settings and implementation dates have been previously presented in the Quarterly System Operation Reports (Golder, July 1998, October 1998b, January 1999, and March 1999). However, a review of the Off-Site System's performance is provided:

- Total flow rate for the Off-Site System ranged from a monthly low of approximately 55,142 gallons per day (gpd) during the second quarter (July 1998) of operation to a high of approximately 90,137 gpd during the fourth quarter (January 1999) of operation; and
- During the year the flow rate of individual off-site extraction wells ranged from approximately 23 gallons per minute (gpm) to 24.6 gpm for EW-2; ranged from approximately 9 gpm to 12 gpm for EW-3; ranged from approximately 5.3 gpm to 7 gpm for EW-4; and ranged from approximately 7.8 gpm to 9 gpm for EW-5.

### 4.2 On-Site System

There were four operational changes made to the On-Site System during the past year. On May 26, 1998, DW-9 was taken off-line in order to focus On-Site remedial efforts on the southern facility property line near wells EW-7 and EW-8. On June 2, 1998, the off-gas from the air strippers in the treatment building was redirected through a new, taller, stack directly to the building exterior instead of through the thermal oxidizer and scrubber system in accordance with Textron's NYSDEC approved revised air permit. On September 25, 1998, EW-13 was brought on-line to supplement the hydraulic barrier between EW-7 and EW-8. On January 15, 1999, a float switch was fitted to the treatment building sump which will indicate an alarm condition, shut down the treatment plant, and activate the service auto-dialer in the event of high sump liquid levels. Downtime, generally associated with the system changes noted above, has been minor. No downtime reports were required to be submitted to the NYSDEC this year.

Specific pump flow settings and implementation dates have been previously presented in the Quarterly System Operation Reports (Golder, July 1998, October 1998b, January 1999, and March 1999). However, a review of the On-Site System's performance is provided:

- The average influent flow to the treatment plant ranged from a monthly low of approximately 25,200 gpd during the second quarter (July 1998) of operation to a high of approximately 61,920 gpd during the first quarter (April 1998); and
- During the year the flow rate of individual on-site extraction wells ranged from approximately 4.9 gpm to 9.7 gpm for EW-7; ranged from approximately 6 gpm to 9 gpm for EW-8; ranged from approximately 3.2 gpm to 8.4 gpm for DW-9 (prior to shutdown); ranged from approximately 3.5 gpm to 6.9 gpm for DW-10; ranged from approximately 2.5 gpm to 10 gpm for DW-11; ranged from approximately 4.8 gpm to 11.3 gpm for DW-12; and ranged from approximately 8.8 gpm to 11 gpm for EW-13.

## 5. RECOMMENDATIONS FOR FUTURE GROUNDWATER MONITORING AND SYSTEM OPERATIONS

This section presents recommendations for future groundwater monitoring of the On-Site and Off-Site Systems as well as recommendations for future operations of the Systems.

Textron proposes the following recommendations:

- Textron proposes to change the frequency of groundwater quality monitoring for five interior On-Site monitoring wells from the current annual sampling to sampling once every other year. The wells under consideration are 87-01(0), 87-01(1), 87-02(1), 87-08(1), and 87-14(0). Generally, these wells have been sampled quarterly or semi-annually for approximately the last five years and with lesser frequency back to the time of the wells' installations in 1987, so a large amount of historical analytical data has been obtained. Due to the anticipated long-term nature of the remedial efforts in this area, the predictable nature of the chemistry changes through time in these wells, the interior location of the wells, and the desire to conserve remedial budgets, Textron believes that a 2-year sampling interval is sufficient to monitor the groundwater quality in this area. Wells on the perimeter of the On-Site area and the On-Site extraction wells will continue to be monitored for groundwater quality on the current schedule (annually). No changes are proposed for the hydraulic monitoring frequency (quarterly) for these wells.
- No changes for future hydraulic monitoring are currently proposed for the On-Site or Off-Site systems.

## 6. SUMMARY

The Off-Site System has been operating since start-up of the system in March 1993. Twenty-four quarterly monitoring events have been performed during the past six years of operation of the Off-Site System. The data collected from these monitoring events indicates that the Off-Site System is operating as intended, as a cone-of-depression has developed in the Zone 1 aquifer which sufficiently overlaps the dissolved phase contamination in the off-site area. Therefore, Textron will continue to operate the Off-Site System based on its current mode of operation. The suspension of pumping of EW-6 will continue as before.

The hydraulic response of the On-Site System has met the design expectations of establishing a zone of groundwater capture over the DNAPL plume; maintaining an upward gradient between the Zone 3 and Zone 1 aquifers; maintaining a downward gradient between the overburden and the Zone 1 aquifer; and establishing a groundwater zone of capture along the southern property boundary of the Textron facility, between extraction wells EW-7, EW-13, and EW-8. Therefore, Textron will continue to operate the On-Site System based on its current mode of operation. The suspension of pumping of DW-9 has caused no degradation of system performance and will continue as before.

GOLDER ASSOCIATES INC.

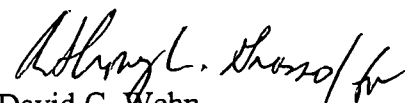
  
David C. Wehn  
Project Hydrogeologist

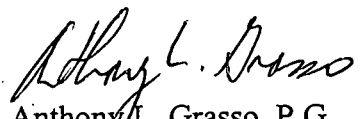
  
Anthony L. Grasso, P.G.  
Project Director/Associate

DCW/ALG:dml

F/N: C:\Common\Projects\973-9158\Reports\98-99ANN\STHANN.DOC

## REFERENCES

- Golder Associates Inc., June 1991, "RCRA Facility Investigation, Neutralization Pond, Bell Aerospace Textron, Wheatfield Plant," Volumes I and II.
- Golder Associates Inc., February 1993, "Ground Water Monitoring Plan, Bell Aerospace Textron, Wheatfield, New York, February 1993 Revision".
- Golder Associates Inc., March 1998, "1997-1998 Annual Summary and System Performance, Off-Site and On-Site Groundwater Extraction Systems, Textron Realty Operations (Wheatfield), Inc. Facility, Wheatfield, New York."
- Golder Associates Inc., July 1998, "April 1998 Semi-Annual Groundwater Monitoring Event and Summary of Off-Site and On-Site Groundwater Extraction System Operation, Textron Inc. Wheatfield Facility, Wheatfield, New York."
- Golder Associates Inc., October 1998a, "Groundwater Monitoring Plan, Former Textron Inc. Wheatfield, New York Facility, October 1998 Revision."
- Golder Associates Inc., October 1998b, "July 1998 Quarterly Hydraulic Monitoring Event and Summary of Off-Site and On-Site Groundwater Extraction System Operation, Former Textron Inc. Wheatfield, New York Facility."
- Golder Associates Inc., January 1999, "October 1998 Annual Groundwater Monitoring Event and Summary of Off-Site and On-Site Groundwater Extraction System Operation, Former Textron Inc. Wheatfield, New York Facility."
- Golder Associates Inc., March 1999, "January 1999 Quarterly Hydraulic Monitoring Event and Summary of Off-Site and On-Site Groundwater Extraction System Operation, Former Textron Inc. Wheatfield, New York Facility."



TABLE 1  
 GROUNDWATER QUALITY MONITORING POINTS  
 FOR THE ON-SITE AND OFF-SITE  
 EFFECTIVENESS MONITORING PROGRAMS  
 FORMER TEXTRON INC.  
 WHEATFIELD, NEW YORK FACILITY

WELL NUMBER	FREQUENCY	ANALYTICAL METHOD
	ANNUAL (A)	
<b>OVERBURDEN MONITORING WELLS</b>		
87-01(0)	X	8260
87-10(0)	X	8260
87-14(0)	X	8260
87-18(0)	X	8260
87-20(0)	X	8260
87-22(0)	X	8260
87-23(0)	X	8260
89-14(0)	X	8260
B-8	X	8260
<b>TOTAL OVERBURDEN SAMPLES PER EVENT</b>		<b>9</b>
<b>ZONE 1 MONITORING WELLS</b>		
87-01(1)	X	8260
87-02(1)	X	8260
87-08(1)	X	8260
87-17(1)	X	8260
87-19(1)	X	8260
87-20(1)	X	8260
87-21(1)	X	8260
87-22(1)	X	8260
89-02(1) *	X	8260
89-03(1)	X	8260
89-04(1)	X	8260
89-14(1)	X	8260
89-15(1)	X	8260
89-16(1)	X	8260
89-17(1)	X	8260
93-03(1)	X	8260
94-02(1)	X	8260
B-14(1)	X	8260
<b>TOTAL ZONE 1 SAMPLES PER EVENT</b>		<b>18</b>
<b>ZONE 3 MONITORING WELLS</b>		
87-02(3)	X	8260
87-13(3)	X	8260
89-02(3) *	X	8260
<b>TOTAL ZONE 3 SAMPLES PER EVENT</b>		<b>3</b>
<b>OFF-SITE EXTRACTION WELLS</b>		
EW-2	X	8260
EW-3	X	8260
EW-4	X	8260
EW-5	X	8260
EW-6	X	8260
<b>TOTAL OFF-SITE EXTRACTION WELL SAMPLES PER EVENT</b>		<b>5</b>

(A) Annual sampling to be conducted in October.

A water level reading will be taken from each well shown during each monitoring event.

\* Decommissioned after annual sampling event in October 1998.

TABLE 1  
 GROUNDWATER QUALITY MONITORING POINTS  
 FOR THE ON-SITE AND OFF-SITE  
 EFFECTIVENESS MONITORING PROGRAMS  
 FORMER TEXTRON INC.  
 WHEATFIELD, NEW YORK FACILITY

WELL NUMBER	FREQUENCY	ANALYTICAL METHOD
	ANNUAL (A)	
<b>ON-SITE EXTRACTION WELLS</b>		
EW-7	X	8260
EW-8	X	8260
DW-9	X	8260
DW-10	X	8260
DW-11	X	8260
DW-12	X	8260
<b>TOTAL ON-SITE EXTRACTION WELL SAMPLES PER EVENT</b>	<b>6</b>	
<b>GRAND TOTAL SAMPLES PER EVENT</b>	<b>41</b>	

(A) Annual sampling to be conducted in October.  
 A water level reading will be taken from each well shown during each monitoring event.

TABLE 2  
SUMMARY OF GROUNDWATER ANALYTICAL DATA (1)  
APRIL 1998 SEMI-ANNUAL MONITORING EVENT  
FORMER TEXTRON INC.  
WHEATFIELD, NEW YORK FACILITY

ANALYTICAL METHOD EPA 8260  
(Concentrations in µg/L)

SAMPLE LOCATION	87-02(3)	87-13(3)	87-19(1)	87-20(1)	87-21(1)	89-02(3)	89-03(1)
SAMPLE I.D.	BAT87023980420	BAT87133980423	BAT87191980422	BAT87201980420	BAT87211980421	BAT89023980421	BAT89031980422
SAMPLE DATE	4/20/98	4/23/98	4/22/98	4/20/98	4/20/98	4/20/98	4/22/98
PARAMETER							
VINYL CHLORIDE	-	15	-	720	-	-	-
1 1-DICHLOROETHENE	-	-	-	-	-	-	-
ACETONE	-	11 B	-	-	-	-	-
CARBON DISULFIDE	5	38	2	-	-	4	-
METHYLENE CHLORIDE	-	-	-	-	-	-	-
TRANS-1 2-DICHLOROETHENE	-	-	-	-	-	-	-
1 1-DICHLOROETHANE	-	-	-	-	-	-	-
CIS-1 2-DICHLOROETHENE	-	67	7	9700	37	-	11
1 1 1-TRICHLOROETHANE	-	-	-	-	-	-	-
TRICHLOROETHENE	-	150	3	430	-	-	-
STYRENE	-	-	-	-	-	-	1 B
BROMOFORM	-	-	-	-	-	-	-

**NOTES:**

- 1 = Only sample locations with detected compounds are listed.
- = Compound not detected at the Practical Quantitation Limit; refer to Appendix C for Practical Quantitation Limits.
- \* = Duplicate Sample
- B = Analyte was detected in the method or trip blank.

TABLE 2  
SUMMARY OF GROUNDWATER ANALYTICAL DATA (1)  
APRIL 1998 SEMI-ANNUAL MONITORING EVENT  
FORMER TEXTRON INC.  
WHEATFIELD, NEW YORK FACILITY

ANALYTICAL METHOD EPA 8260  
(Concentrations in µg/L)

SAMPLE LOCATION	89-04(1)	89-05(1A)	89-14(0)	93-03(1)	DW-9	*	DW-10
SAMPLE I.D.	BAT89041980421	BAT89051A980421	BAT89140980422	BAT93031980422	BATDW9980423	BATDW9DUP980423	BATDW10980423
SAMPLE DATE	4/20/98	4/20/98	4/22/98	4/22/98	4/23/98	4/23/98	4/23/98
PARAMETER							
VINYL CHLORIDE	-	48	-	-	150	150	-
1 1-DICHLOROETHENE	3	2	-	-	21	21	-
ACETONE	-	-	-	-	-	-	-
CARBON DISULFIDE	110	3	-	2	15	17	210
METHYLENE CHLORIDE	-	-	-	-	6300	6300	15000
TRANS-1 2-DICHLOROETHENE	-	1	-	-	15	16	-
1 1-DICHLOROETHANE	-	-	-	-	28	29	-
CIS-1 2-DICHLOROETHENE	18	190	-	-	3600	3600	610
1 1 1-TRICHLOROETHANE	-	2	-	-	290	310	-
TRICHLOROETHENE	6	4	-	-	4500	4700	950
STYRENE	-	-	1 B	-	-	-	-
BROMOFORM	-	-	-	-	-	-	-

**NOTES:**

- 1 = Only sample locations with detected compounds are listed.
- = Compound not detected at the Practical Quantitation Limit; refer to Appendix C for Practical Quantitation Limits.
- \* = Duplicate Sample
- B = Analyte was detected in the method or trip blank.

TABLE 2  
SUMMARY OF GROUNDWATER ANALYTICAL DATA (1)  
APRIL 1998 SEMI-ANNUAL MONITORING EVENT  
FORMER TEXTRON INC.  
WHEATFIELD, NEW YORK FACILITY

ANALYTICAL METHOD EPA 8260  
(Concentrations in µg/L)

SAMPLE LOCATION	DW-11	DW-12	EW-6	EW-7	EW-8
SAMPLE I.D.	BATEW11980422	BATDW12980422	BATEW6980420	BATEW7980420	BATEW8980420
SAMPLE DATE	4/22/98	4/22/98	4/20/98	4/20/98	4/20/98
PARAMETER					
VINYL CHLORIDE	150	120	11	500	110
1 1-DICHLOROETHENE	-	-	-	-	-
ACETONE	-	1100 B	-	-	-
CARBON DISULFIDE	-	-	1	-	-
METHYLENE CHLORIDE	5400	530	-	-	-
TRANS-1 2-DICHLOROETHENE	-	-	-	-	-
1 1-DICHLOROETHANE	-	-	-	-	-
CIS-1 2-DICHLOROETHENE	2800	5800	33	2800	1300
1 1 1-TRICHLOROETHANE	620	-	-	-	-
TRICHLOROETHENE	15000	7300	-	88	430
STYRENE	-	-	-	-	-
BROMOFORM	-	-	-	-	-

**NOTES:**

- 1 = Only sample locations with detected compounds are listed.
- = Compound not detected at the Practical Quantitation Limit; refer to Appendix C for Practical Quantitation Limits.
- \* = Duplicate Sample
- B = Analyte was detected in the method or trip blank.

MARCH 1999

973-9158

TABLE 3  
 SUMMARY OF GROUNDWATER ANALYTICAL DATA (1)  
 OCTOBER 1998 ANNUAL MONITORING EVENT  
 FORMER TEXTRON INC.  
 WHEATFIELD, NEW YORK FACILITY

ANALYTICAL METHOD EPA 8260  
 (Concentrations in ug/L)

SAMPLE LOCATION	87-01(1)	87-02(1)	87-02(3) *	87-08(1)	87-10(0)	87-13(3)	87-14(0)	87-17(1)
SAMPLE I.D.	BAT87011981029	BAT87021981029	BAT87023981029DUP	BAT87081981029	BAT87100981029	BAT87133981030	BAT87140981029	BAT87171981030
SAMPLE DATE	10/29/98	10/29/98	10/29/98	10/29/98	10/29/98	10/30/98	10/29/98	10/30/98
PARAMETER								
VINYL CHLORIDE	170	20 J	-	120	-	19	-	91
1 1-DICHLOROETHENE	-	-	-	-	-	-	-	3 J
CARBON DISULFIDE	-	-	1	-	-	35	-	-
METHYLENE CHLORIDE	-	-	-	-	-	-	-	61
TRANS-1 2-DICHLOROETHENE	-	-	-	-	2 J	-	-	2 J
1 1-DICHLOROETHANE	-	8 J	-	-	6	-	-	17
CIS-1 2-DICHLOROETHENE	1000	360	-	1800	130	62	4800	540
CHLOROFORM	-	-	-	-	2	-	-	-
1 1 1-TRICHLOROETHANE	-	20 J	-	-	16	-	-	74
TRICHLOROETHENE	38 J	300	-	56	6	92	17000	28

NOTES:

- 1 = Only sample locations with detected compounds are listed.
- = Compound not detected at the Practical Quantitation Limit; refer to Appendix C for Practical Quantitation Limits.
- \* = Duplicate Sample
- J = Result estimated below the quantitation limit.
- E = Estimated

MARCH 1999

TABLE 3  
SUMMARY OF GROUNDWATER ANALYTICAL DATA (1)  
OCTOBER 1998 ANNUAL MONITORING EVENT  
FORMER TEXTRON INC.  
WHEATFIELD, NEW YORK FACILITY

973-9158

ANALYTICAL METHOD EPA 8260  
(Concentrations in ug/L)

SAMPLE LOCATION	87-19(1)	87-19(1) *	87-20(1)	87-21(1)	87-22(1)	89-02(1)	89-02(3)	89-03(1)
SAMPLE I.D.	BAT87191981027	BAT87191981027DUP	BAT87201981028	BAT87211981028	BAT87221981028	BAT89021981028	BAT89023981028	BAT89031981027
SAMPLE DATE	10/27/98	10/27/98	10/28/98	10/27/98	10/28/98	10/28/98	10/28/98	10/27/98
PARAMETER								
VINYL CHLORIDE	-	-	-	54	130	81	-	-
1 1-DICHLOROETHENE	-	-	-	-	-	-	-	-
CARBON DISULFIDE	-	-	-	-	-	-	2	-
METHYLENE CHLORIDE	-	-	-	-	-	-	-	-
TRANS-1 2-DICHLOROETHENE	-	-	-	-	-	-	-	-
1 1-DICHLOROETHANE	-	-	-	-	-	-	-	-
CIS-1 2-DICHLOROETHENE	8	5	11000	1200	1800	710	-	64
CHLOROFORM	-	-	-	-	-	-	-	-
1 1 1-TRICHLOROETHANE	-	-	-	-	-	-	-	-
TRICHLOROETHENE	4	2 J	1800	700	-	260	-	-

**NOTES:**

- 1 = Only sample locations with detected compounds are listed.
- = Compound not detected at the Practical Quantitation Limit; refer to Appendix C for Practical Quantitation Limits.
- \* = Duplicate Sample
- J = Result estimated below the quantitation limit.
- E = Estimated

MARCH 1999

973-9158

TABLE 3  
 SUMMARY OF GROUNDWATER ANALYTICAL DATA (1)  
 OCTOBER 1998 ANNUAL MONITORING EVENT  
 FORMER TEXTRON INC.  
 WHEATFIELD, NEW YORK FACILITY

ANALYTICAL METHOD EPA 8260  
 (Concentrations in ug/L)

SAMPLE LOCATION	89-04(1)	89-14(1)	89-15(1)	93-03(1)	B-14(1)	DW-9	DW-10	DW-11
SAMPLE ID	BAT89041981027	BAT89141981028	BAT89151981029	93-03 (1)	BATB141981029	BATDW9981030	BATDW10981029	BATEW11981029
SAMPLE DATE	10/27/98	10/28/98	10/29/98	10/27/98	10/29/98	10/30/98	10/29/98	10/29/98
PARAMETER								
VINYL CHLORIDE	4	27	-	-	100	130 J	-	230
1 1-DICHLOROETHENE	3	-	-	-	2 J	-	-	-
CARBON DISULFIDE	99	-	-	-	-	-	-	-
METHYLENE CHLORIDE	-	-	4500	-	-	-	17000	5800
TRANS-1 2-DICHLOROETHENE	-	-	-	-	2 J	-	-	-
1 1-DICHLOROETHANE	-	13	-	-	9	-	-	-
CIS-1 2-DICHLOROETHENE	19	500	750 J	3 J	380 E	4200	1400	4000
CHLOROFORM	-	-	-	-	-	-	-	-
1 1 1-TRICHLOROETHANE	-	22	-	-	33	-	-	760
TRICHLOROETHENE	6	30	16000	-	3 J	340 J	1500	14000

NOTES:

- 1 = Only sample locations with detected compounds are listed.
- = Compound not detected at the Practical Quantitation Limit; refer to Appendix C for Practical Quantitation Limits.
- \* = Duplicate Sample
- J = Result estimated below the quantitation limit.
- E = Estimated



MARCH 1999

TABLE 3  
 SUMMARY OF GROUNDWATER ANALYTICAL DATA (1)  
 OCTOBER 1998 ANNUAL MONITORING EVENT  
 FORMER TEXTRON INC.  
 WHEATFIELD, NEW YORK FACILITY

973-9158

ANALYTICAL METHOD EPA 8260  
 (Concentrations in ug/L)

SAMPLE LOCATION	DW-12	EW-2	EW-3	EW-4	EW-5	EW-6	EW-7	EW-8
SAMPLE I.D.	BATDW12981029	BATEW2981027	BATEW3981027	BATEW4981027	BATEW5981027	BATEW6981027	BATEW7981029	BATEW8981029
SAMPLE DATE	10/29/98	10/27/98	10/27/98	10/27/98	10/27/98	10/27/98	10/29/98	10/29/98
PARAMETER								
VINYL CHLORIDE	420	170	480	29	42	11	3600	210 J
1 1-DICHLOROETHENE	-	-	-	-	2	-	-	-
CARBON DISULFIDE	-	-	-	-	-	-	-	-
METHYLENE CHLORIDE	270	-	-	-	-	-	-	-
TRANS-1 2-DICHLOROETHENE	-	-	-	-	1	-	-	-
1 1-DICHLOROETHANE	-	-	-	-	-	-	-	-
CIS-1 2-DICHLOROETHENE	6600	2400	3700	130	83	32	2700	2500
CHLOROFORM	-	-	-	-	-	-	-	-
1 1 1-TRICHLOROETHANE	-	-	-	-	-	-	-	-
TRICHLOROETHENE	6100	50 J	49 J	11	1	-	-	690

NOTES:

- 1 = Only sample locations with detected compounds are listed.
- = Compound not detected at the Practical Quantitation Limit; refer to Appendix C for Practical Quantitation Limits.
- \* = Duplicate Sample
- J = Result estimated below the quantitation limit.
- E = Estimated

TABLE 4  
SUMMARY OF HYDRAULIC MONITORING DATA  
APRIL 1998 SEMI-ANNUAL MONITORING EVENT  
FORMER TEXTRON INC.  
WHEATFIELD, NEW YORK FACILITY  
(Measurements Recorded April 17, 1998)

WELL NAME	TOP OF RISER ELEVATION (FT. MSL)	WATER LEVEL (FT. BTOR)	WATER LEVEL ELEVATION (FT. MSL)
87-01(0)	588.10	13.71	574.39
87-01(1)	587.99	15.75	572.24
87-02(1)	589.21	15.99	573.22
87-02(3)	588.63	12.82	575.81
87-04(0)	589.32	10.50	578.82
87-04(1)	589.08	14.00	575.08
87-04(3)	589.49	12.50	576.99
87-05(1)	589.37	14.01	575.36
87-05(3)	589.46	11.97	577.49
87-06(1)	588.27	13.08	575.19
87-08(1)	589.48	14.97	574.51
87-10(0)	587.30	12.51	574.79
87-10(1)	587.52	15.67	571.85
87-12(1)	583.84	14.30	569.54
87-13(0)	589.77	9.05	580.72
87-13(1)	590.06	15.31	574.75
87-13(3)	589.91	12.53	577.38
87-14(0)	589.56	10.18	579.38
87-14(1)	589.06	15.76	573.30
87-14(3)	590.35	12.50	577.85
87-15(0)	590.70	12.66	578.04
87-15(1)	590.27	13.71	576.56
87-15(3)	589.87	11.84	578.03
87-16(3B)	590.51	12.68	577.83
87-17(0)	589.50	11.70	577.80
87-17(1)	589.62	11.92	577.70
87-18(0)	585.95	12.73	573.22
87-18(1)	586.02	17.75	568.27
87-19(0)	581.57	2.62	578.95
87-19(1)	581.47	12.18	569.29
87-20(0)	578.77	5.00	573.77
87-20(1)	579.01	9.66	569.35
87-21(0)	577.23	8.84	568.39
87-21(1)	577.33	8.23	569.10
87-22(0)	583.80	7.95	575.85
87-22(1)	583.97	13.83	570.14
87-23(0)	587.27	4.62	582.65
87-23(1)	587.13	14.66	572.47
89-02(1)	584.69	13.63	571.06
89-02(3)	584.80	10.35	574.45
89-03(1)	581.01	14.77	566.24
89-04(1)	577.92	6.87	571.05

TABLE 4  
SUMMARY OF HYDRAULIC MONITORING DATA  
APRIL 1998 SEMI-ANNUAL MONITORING EVENT  
FORMER TEXTRON INC.  
WHEATFIELD, NEW YORK FACILITY  
(Measurements Recorded April 17, 1998)

WELL NAME	TOP OF RISER ELEVATION (FT. MSL)	WATER LEVEL (FT. BTOR)	WATER LEVEL ELEVATION (FT. MSL)
89-05(1A)	577.56	15.01	562.55
89-05(1B)	577.77	9.53	568.24
89-06(1)	575.93	9.67	566.26
89-07(1A)	577.66	11.62	566.04
89-07(1B)	577.48	10.79	566.69
89-12(1)	586.60	15.18	571.42
89-13(0)	588.18	11.47	576.71
89-14(0)	587.45	10.03	577.42
89-14(1)	587.59	13.80	573.79
89-15(1)	588.76	16.56	572.20
89-16(1)	576.76	5.71	571.05
89-17(1)	577.59	6.41	571.18
89-18(1)	576.75	12.55	564.20
93-02(1)	579.05	18.38	560.67
93-03(1)	572.30	12.00	560.30
94-02(1)	574.50	8.37	566.13
96-01(1)	585.18	15.74	569.44
96-02(1)	584.82	15.53	569.29
B-8(0)	590.26	10.37	579.89
B-12(0)	589.48	12.26	577.22
B-13(1)	588.41	13.32	575.09
B-14(1)	589.54	14.60	574.94
89-SW(2)	577.54	8.40	569.14
EW-2	568.15	N/A	561.90
EW-3	569.56	N/A	556.00
EW-4	570.07	N/A	555.40
EW-5	569.47	N/A	553.60
EW-6	568.17	N/A	563.40
EW-7 (1)	580.96	14.01	566.95
EW-8 (1)	578.44	13.50	564.94
DW-9 (1)	581.30	12.45	568.85
DW-10 (1)	583.95	9.08	574.87
DW-11 (1)	583.05	9.39	573.66
DW-12 (1)	580.48	9.41	571.07

**NOTES:**

BTOR = Below top of riser (or measuring point).

MSL = Mean sea level.

N/A = Not applicable, measurement taken from electronic readout in vault.

(1) = Water level elevation measured from top of vault grate.

TABLE 5  
SUMMARY OF HYDRAULIC MONITORING DATA  
JULY 1998 MONITORING EVENT  
FORMER TEXTRON INC.  
WHEATFIELD, NEW YORK FACILITY  
(Measurements Recorded July 24 and July 27, 1998)

WELL NAME	TOP OF RISER ELEVATION (FT. MSL)	WATER LEVEL (FT. BTOR)	WATER LEVEL ELEVATION (FT. MSL)
87-01(0)	588.10	15.02	573.08
87-01(1)	587.99	18.61	569.38
87-02(1)	589.21	18.51	570.70
87-02(3)	588.63	14.02	574.61
87-04(0)	589.32	12.00	577.32
87-04(1)	589.08	16.10	572.98
87-04(3)	589.49	13.76	575.73
87-05(1)	589.37	17.09	572.28
87-05(3)	589.46	13.39	576.07
87-06(1)	588.27	15.31	572.96
87-08(1)	589.48	15.34	574.14
87-10(0)	587.30	14.48	572.82
87-10(1)	587.52	18.59	568.93
87-12(1)	583.84	18.76	565.08
87-13(0)	589.77	9.62	580.15
87-13(1)	590.06	16.81	573.25
87-13(3)	589.91	13.92	575.99
87-14(0)	589.56	11.45	578.11
87-14(1)	589.06	15.65	573.41
87-14(3)	590.35	13.99	576.36
87-15(0)	590.70	13.64	577.06
87-15(1)	590.27	15.08	575.19
87-15(3)	589.87	13.42	576.45
87-16(3B)	590.51	14.18	576.33
87-17(0)	589.50	12.02	577.48
87-17(1)	589.62	13.49	576.13
87-18(0)	585.95	12.59	573.36
87-18(1)	586.02	21.14	564.88
87-19(0)	581.57	7.92	573.65
87-19(1)	581.47	15.77	565.70
87-20(0)	578.77	6.79	571.98
87-20(1)	579.01	14.00	565.01
87-21(0)	577.23	DRY	DRY
87-21(1)	577.33	12.49	564.84
87-22(0)	583.80	DRY	DRY
87-22(1)	583.97	17.47	566.50
87-23(0)	587.27	8.35	578.92
87-23(1)	587.13	16.64	570.49
89-02(1)	584.69	16.79	567.90
89-02(3)	584.80	11.52	573.28
89-03(1)	581.01	16.72	564.29
89-04(1)	577.92	Bees	Nest

TABLE 5  
SUMMARY OF HYDRAULIC MONITORING DATA  
JULY 1998 MONITORING EVENT  
FORMER TEXTRON INC.  
WHEATFIELD, NEW YORK FACILITY  
(Measurements Recorded July 24 and July 27, 1998)

WELL NAME	TOP OF RISER ELEVATION (FT. MSL)	WATER LEVEL (FT. BTOR)	WATER LEVEL ELEVATION (FT. MSL)
89-05(1A)	577.56	18.42	559.14
89-05(1B)	577.77	13.35	564.42
89-06(1)	575.93	11.73	564.20
89-07(1A)	577.66	13.80	563.86
89-07(1B)	577.48	13.99	563.49
89-12(1)	586.60	18.10	568.50
89-13(0)	588.18	13.62	574.56
89-14(0)	587.45	DRY	DRY
89-14(1)	587.59	13.85	573.74
89-15(1)	588.76	18.66	570.10
89-16(1)	576.76	8.91	567.85
89-17(1)	577.59	9.19	568.40
89-18(1)	576.75	15.73	561.02
93-02(1)	579.05	21.96	557.09
93-03(1)	572.30	15.04	557.26
94-02(1)	574.50	10.62	563.88
96-01(1)	585.18	19.58	565.60
96-02(1)	584.82	19.48	565.34
B-8(0) (*)	590.26	13.61	576.65
B-12(0) (*)	589.48	13.14	576.34
B-13(1)	588.41	15.50	572.91
B-14(1)	589.54	16.71	572.83
89-SW(2) (*)	577.54	13.61	563.93
EW-2	568.15	N/A	558.30
EW-3	569.56	N/A	552.30
EW-4	570.07	N/A	550.70
EW-5	569.47	N/A	550.30
EW-6	568.17	N/A	(***)
EW-7 (**)	580.96	15.84	565.12
EW-8 (**)	578.44	12.45	565.99
DW-9 (*) (**)	581.30	7.74	573.56
DW-10 (**)	583.95	11.97	571.98
DW-11 (**)	583.05	13.09	569.96
DW-12 (**)	580.48	12.25	568.23

**NOTES:**

BTOR = Below top of riser (or measuring point).

MSL = Mean sea level.

N/A = Not applicable, measurement taken from electronic readout in vault.

(\*) Water level measurements taken on 7/27/98.  
All others taken on 7/24/98.

(\*\*) Water level elevation measured from top of vault grate.

(\*\*\*) Water level elevation was not obtained due to inoperable readout.

Bees Nest = Water level measurement not taken at this location due to a bees nest located in the well casing.

TABLE 6  
 SUMMARY OF HYDRAULIC MONITORING DATA  
 OCTOBER 1998 MONITORING EVENT  
 FORMER TEXTRON INC.  
 WHEATFIELD, NEW YORK FACILITY  
 (Measurements Recorded October 26, 1998)

WELL NAME	TOP OF RISER ELEVATION (FT. MSL)	WATER LEVEL (FT. BTOR)	WATER LEVEL ELEVATION (FT. MSL)
87-01(0)	588.10	DRY	DRY
87-01(1)	587.99	20.27	567.72
87-02(1)	589.21	20.62	568.59
87-02(3)	588.63	15.53	573.10
87-04(0)	589.32	14.48	574.84
87-04(1)	589.08	17.25	571.83
87-04(3)	589.49	15.18	574.31
87-05(1)	589.37	18.50	570.87
87-05(3)	589.46	14.84	574.62
87-06(1)	588.27	17.20	571.07
87-08(1)	589.48	17.31	572.17
87-10(0)	587.30	15.81	571.49
87-10(1)	587.52	20.66	566.86
87-12(1)	583.84	22.42	561.42
87-13(0)	589.77	11.22	578.55
87-13(1)	590.06	18.10	571.96
87-13(3)	589.91	15.37	574.54
87-14(0)	589.56	13.35	576.21
87-14(1)	589.06	17.18	571.88
87-14(3)	590.35	15.47	574.88
87-15(0)	590.70	15.60	575.10
87-15(1)	590.27	16.79	573.48
87-15(3)	589.87	14.88	574.99
87-16(3B)	590.51	15.65	574.86
87-17(0)	589.50	13.63	575.87
87-17(1)	589.62	14.92	574.70
87-18(0)	585.95	11.64	574.31
87-18(1)	586.02	24.43	561.59
87-19(0)	581.57	9.20	572.37
87-19(1)	581.47	19.33	562.14
87-20(0)	578.77	6.94	571.83
87-20(1)	579.01	17.50	561.51
87-21(0)	577.23	DRY	DRY
87-21(1)	577.33	16.04	561.29
87-22(0) (*)	583.80	DRY	DRY
87-22(1)	583.97	20.54	563.43
87-23(0)	587.27	13.55	573.72
87-23(1)	587.13	18.12	569.01
89-02(1)	584.69	18.63	566.06
89-02(3)	584.80	13.22	571.58
89-03(1)	581.01	18.69	562.32
89-04(1)	577.92	12.00	565.92

TABLE 6  
SUMMARY OF HYDRAULIC MONITORING DATA  
OCTOBER 1998 MONITORING EVENT  
FORMER TEXTRON INC.  
WHEATFIELD, NEW YORK FACILITY  
(Measurements Recorded October 26, 1998)

WELL NAME	TOP OF RISER ELEVATION (FT. MSL)	WATER LEVEL (FT. BTOR)	WATER LEVEL ELEVATION (FT. MSL)
89-05(1A)	577.56	20.85	556.71
89-05(1B)	577.77	16.77	561.00
89-06(1)	575.93	13.91	562.02
89-07(1A)	577.66	16.08	561.58
89-07(1B)	577.48	15.39	562.09
89-12(1)	586.60	20.11	566.49
89-13(0)	588.18	DRY	DRY
89-14(0)	587.45	DRY	DRY
89-14(1)	587.59	15.18	572.41
89-15(1)	588.76	20.05	568.71
89-16(1)	576.76	11.29	565.47
89-17(1)	577.59	12.49	565.10
89-18(1)	576.75	18.43	558.32
93-02(1)	579.05	24.17	554.88
93-03(1)	572.30	17.58	554.72
94-02(1)	574.50	12.89	561.61
96-01(1)	585.18	23.52	561.66
96-02(1)	584.82	23.05	561.77
B-8(0)	590.26	15.73	574.53
B-12(0)	589.48	14.37	575.11
B-13(1)	588.41	17.13	571.28
B-14(1)	589.54	18.00	571.54
89-SW(2)	577.54	16.30	561.24
EW-2	568.15	13.60	554.55
EW-3	569.56	N/A	550.7
EW-4	570.07	N/A	552.0
EW-5	569.47	N/A	549.2
EW-6	568.17	9.50	558.67
EW-7 (**)	580.96	19.50	561.46
EW-8 (**)	578.44	21.30	557.14
DW-9 (**)	581.30	9.01	572.29
DW-10 (**)	583.95	11.87	572.08
DW-11 (**)	583.05	12.23	570.82
DW-12 (**)	580.48	14.25	566.23
EW-13	579.84	24.68	555.16

**NOTES:**

BTOR = Below top of riser (or measuring point).

MSL = Mean sea level.

N/A = Not applicable, measurement taken from electronic readout in vault.

(\*) Lock removed by vandals sometime prior to measuring.

(\*\*) Water level elevation measured from top of vault grate.

TABLE 7  
 SUMMARY OF HYDRAULIC MONITORING DATA  
 JANUARY 1999 MONITORING EVENT  
 FORMER TEXTRON INC.  
 WHEATFIELD, NEW YORK FACILITY  
 (Measurements Recorded January 26, 1999)

WELL NAME	TOP OF RISER ELEVATION (FT. MSL)	WATER LEVEL (FT. BTOR)	WATER LEVEL ELEVATION (FT. MSL)
87-01(0)	588.10	14.82	573.28
87-01(1)	587.99	15.23	572.76
87-02(1)	589.21	15.18	574.03
87-02(3)	588.63	12.93	575.70
87-04(0)	589.32	7.37	581.95
87-04(1)	589.08	12.64	576.44
87-04(3)	589.49	12.65	576.84
87-05(1)	589.37	13.76	575.61
87-05(3)	589.46	11.85	577.61
87-06(1)	588.27	11.89	576.38
87-08(1)	589.48	12.02	577.46
87-10(0)	587.30	11.00	576.30
87-10(1)	587.52	14.90	572.62
87-12(1)	583.84	14.10	569.74
87-13(0)	589.77	8.80	580.97
87-13(1)	590.06	13.40	576.66
87-13(3)	589.91	12.43	577.48
87-14(0)	589.56	9.60	579.96
87-14(1)	589.06	12.30	576.76
87-14(3)	590.35	12.30	578.05
87-15(0)	590.70	14.30	576.40
87-15(1)	590.27	11.98	578.29
87-15(3)	589.87	11.66	578.21
87-16(3B)	590.51	12.52	577.99
87-17(0)	589.50	12.09	577.41
87-17(1)	589.62	11.60	578.02
87-18(0)	585.95	11.89	574.06
87-18(1)	586.02	17.80	568.22
87-19(0)	581.57	3.00	578.57
87-19(1)	581.47	12.79	568.68
87-20(0)	578.77	4.30	574.47
87-20(1)	579.01	9.28	569.73
87-21(0)	577.23	8.55	568.68
87-21(1)	577.33	7.92	569.41
87-22(0)	583.80	DRY	DRY
87-22(1)	583.97	13.99	569.98
87-23(0)	587.27	9.63	577.64
87-23(1)	587.13	13.33	573.80
89-03(1)	581.01	15.05	565.96
89-04(1)	577.92	7.54	570.38
89-05(1A)	577.56	15.25	562.31
89-05(1B)	577.77	9.55	568.22



TABLE 7  
 SUMMARY OF HYDRAULIC MONITORING DATA  
 JANUARY 1999 MONITORING EVENT  
 FORMER TEXTRON INC.  
 WHEATFIELD, NEW YORK FACILITY  
 (Measurements Recorded January 26, 1999)

WELL NAME	TOP OF RISER ELEVATION (FT. MSL)	WATER LEVEL (FT. BTOR)	WATER LEVEL ELEVATION (FT. MSL)
89-06(1)	575.93	10.10	565.83
89-07(1A)	577.66	11.99	565.67
89-07(1B)	577.48	11.24	566.24
89-12(1)	586.60	14.28	572.32
89-13(0)	588.18	9.47	578.71
89-14(0)	587.45	8.03	579.42
89-14(1)	587.59	10.81	576.78
89-15(1)	588.76	15.05	573.71
89-16(1)	576.76	6.15	570.61
89-17(1)	577.59	7.84	569.75
89-18(1)	576.75	12.72	564.03
93-02(1)	579.05	17.99	561.06
93-03(1)	572.30	12.05	560.25
94-02(1)	574.50	8.60	565.90
96-01(1)	585.18	15.79	569.39
96-02(1)	584.82	15.49	569.33
B-8(0)	590.26	12.45	577.81
B-12(0)	589.48	12.41	577.07
B-13(1)	588.41	12.13	576.28
B-14(1)	589.54	13.69	575.85
89-SW(2)	577.54	8.12	569.42
EW-2	568.15	8.35	559.80
EW-3	569.56	N/A	556.5
EW-4	570.07	N/A	549.7
EW-5	569.47	N/A	554.0
EW-6	568.17	6.97	561.20
EW-7 (**)	580.96	14.05	566.91
EW-8 (**)	578.44	9.90	568.54
DW-9 (**)	581.30	2.50	578.80
DW-10 (**)	583.95	8.31	575.64
DW-11 (**)	583.05	9.98	573.07
DW-12 (**)	580.48	8.60	571.88
EW-13	579.84	11.04	568.80

**NOTES:**

BTOR = Below top of riser (or measuring point).

MSL = Mean sea level.

N/A = Not applicable, measurement taken from electronic readout in vault.

(\*\*) Water level elevation measured from top of vault grate.

TABLE 8  
SUMMARY OF VERTICAL HYDRAULIC GRADIENTS

ANNUAL SUMMARY OF SYSTEM OPERATIONS REPORT  
FORMER TEXTRON INC.  
WHEATFIELD, NEW YORK FACILITY

WELL NAME	VERTICAL GRADIENT (dH/dL)			
	April 1998	July 1998	October 1998	January 1999
87-02(1)	0.37	0.56	0.64	0.24
87-02(3)				
87-04(1)	0.27	0.39	0.35	0.06
87-04(3)				
87-05(1)	0.30	0.54	0.54	0.29
87-05(3)				
87-13(1)	0.38	0.39	0.37	0.12
87-13(3)				
87-14(1)	0.65	0.42	0.43	0.18
87-14(3)				
87-15(1)	0.21	0.18	0.22	-0.01
87-15(3)				
89-02(1)	0.48	0.77	0.79	Decommissioned
89-02(3)				

NOTE: Positive vertical gradients are upwards from Zone 3 to Zone 1

MARCH 1999

TABLE 9  
SUMMARY OF OPERATIONS AND MAINTENANCE  
OF MONITORING POINTS  
FORMER TEXTRON INC.  
WHEATFIELD, NEW YORK FACILITY

973-9158

INSPECTION DATE	WELL I.D.	ISSUE	RESOLUTION	COMPLETION DATE
3/3/98*	89-03(1)	Well was repaired - needs resurveyed	Well resurveyed	1/26/98
	89-04(0)	Possible frost heave	Riser elevation checked	4/17/98
10/26/98	89-22(0)	Lock hammered off by vandals	Lock replaced	10/26/98
	89-22(1)	Lock damaged by vandals	Lock replaced	10/26/98

\* = date of letter from NYSDEC to Textron.

N/A = Not Applicable

**FIGURE 2**  
**TVOC CONCENTRATIONS VS. TIME**  
**MONITORING WELL 89-15(1)**

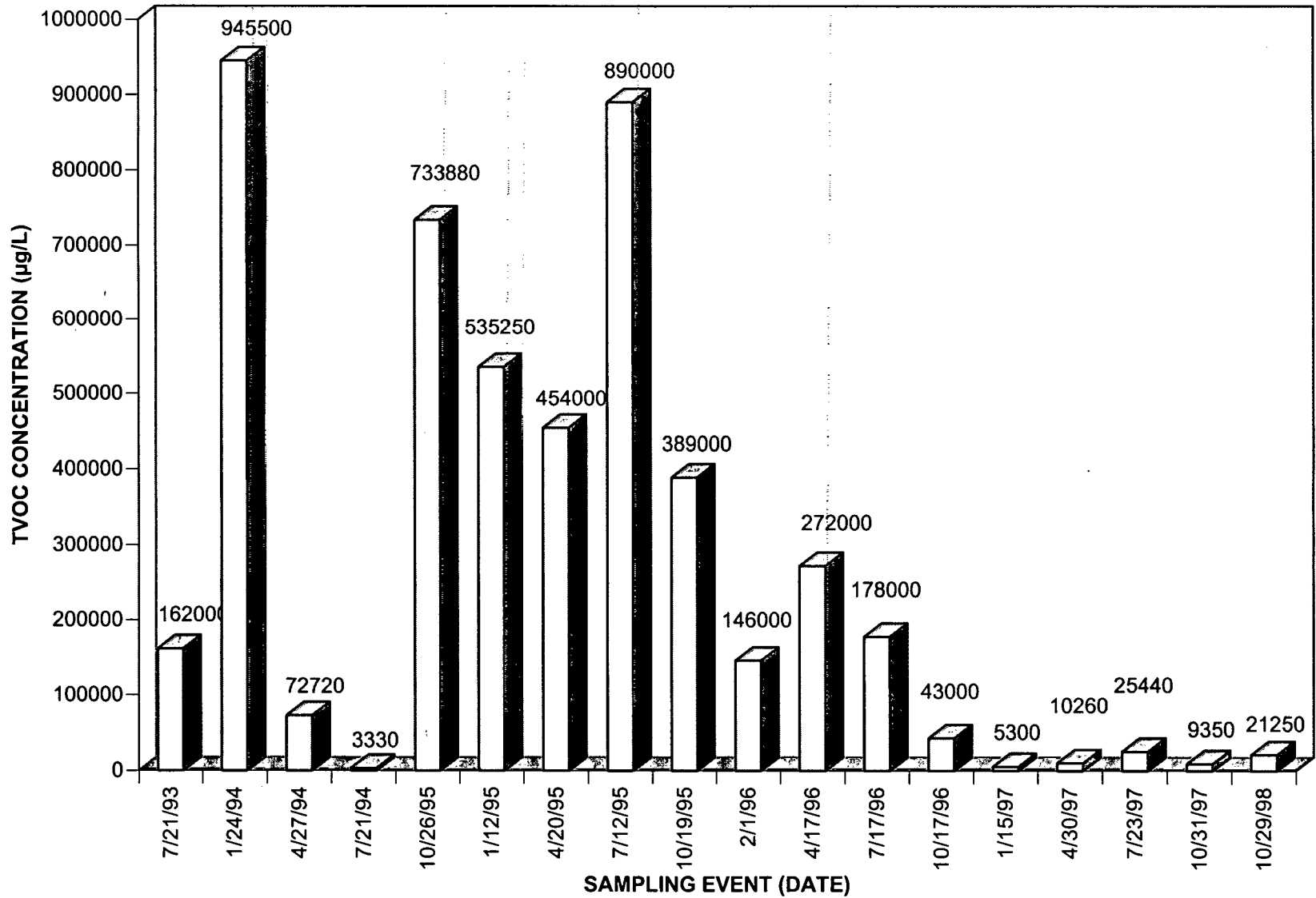

TVOC = Total Volatile Organic Compounds Detected

**FIGURE 3**  
**TVOC CONCENTRATIONS VS. TIME**  
**MONITORING WELL 87-20(1)**

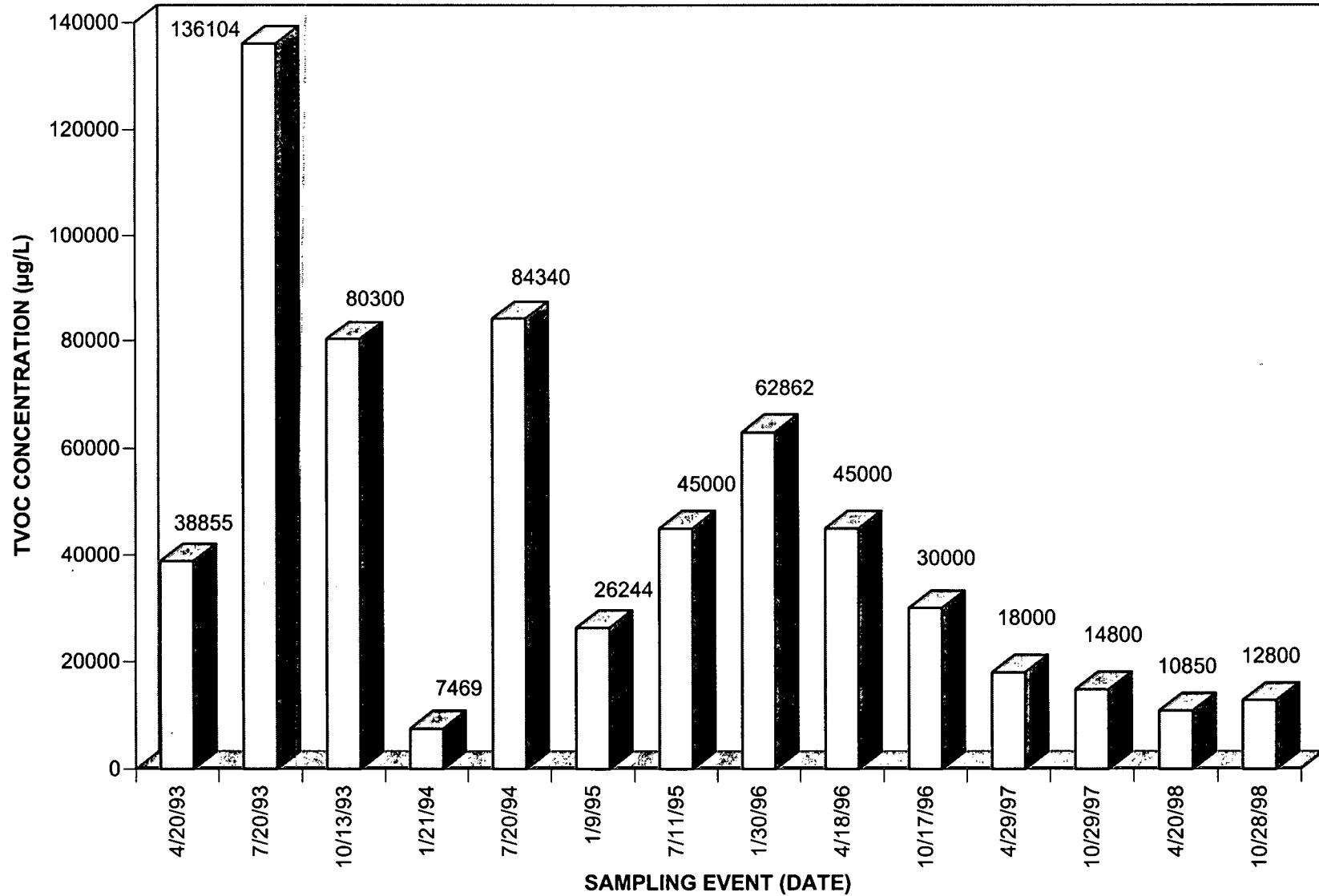

TVOC = Total Volatile Organic Compounds Detected

**FIGURE 4**  
**TVOC CONCENTRATIONS VS. TIME**  
**EXTRACTION WELL EW-4**

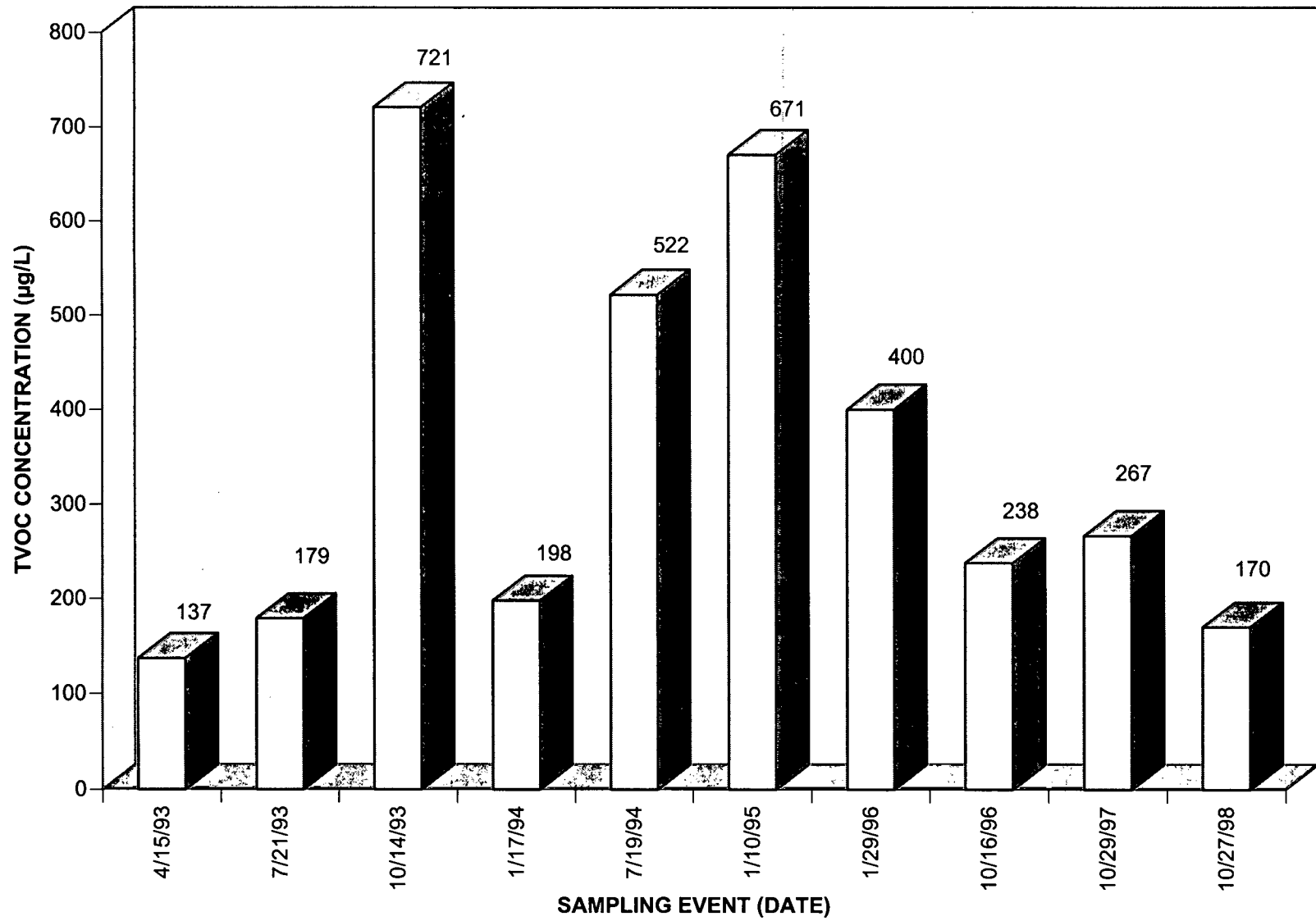

TVOC = Total Volatile Organic Compounds Detected

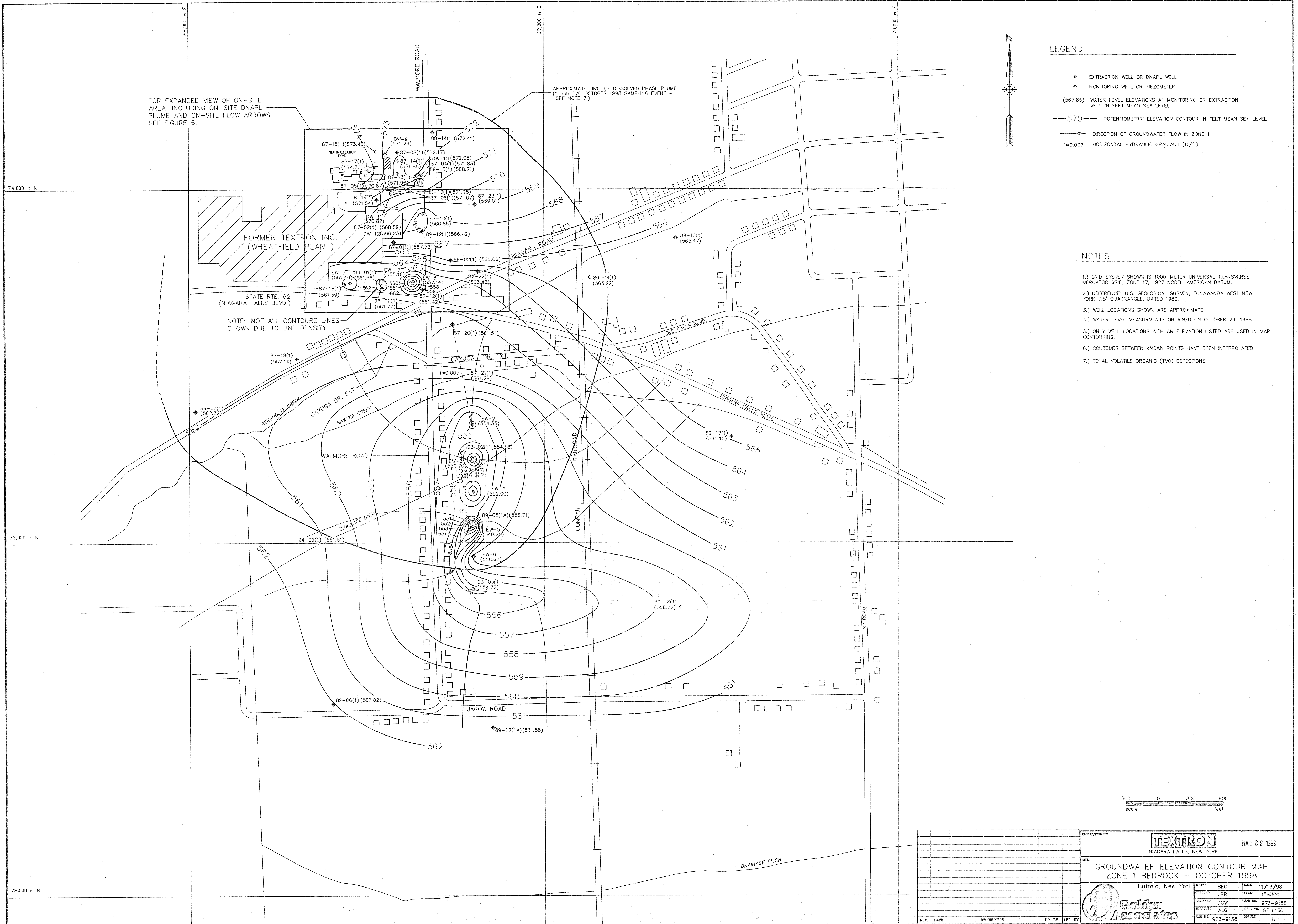

FOR EXPANDED VIEW OF ON-SITE AREA, INCLUDING ON-SITE DNAPL PLUME AND ON-SITE FLOW ARROWS, SEE FIGURE 6.

APPROXIMATE LIMIT OF DISSOLVED PHASE PLUME (1 ppb TVO OCTOBER 1998 SAMPLING EVENT - SEE NOTE 7.)

- LEGEND**
- ◆ EXTRACTION WELL OR DNAPL WELL
  - ⊕ MONITORING WELL OR PIEZOMETER
  - (567.85) WATER LEVEL ELEVATIONS AT MONITORING OR EXTRACTION WELL IN FEET MEAN SEA LEVEL
  - 570— POTENTIOMETRIC ELEVATION CONTOUR IN FEET MEAN SEA LEVEL
  - DIRECTION OF GROUNDWATER FLOW IN ZONE 1
  - i=0.007 HORIZONTAL HYDRAULIC GRADIENT (ft/ft)

- NOTES**
- 1.) GRID SYSTEM SHOWN IS 1000-METER UNIVERSAL TRANSVERSE MERCATOR GRID, ZONE 17, 1927 NORTH AMERICAN DATUM.
  - 2.) REFERENCE: U.S. GEOLOGICAL SURVEY, TONAWANDA WEST NEW YORK 7.5' QUADRANGLE, DATED 1980.
  - 3.) WELL LOCATIONS SHOWN ARE APPROXIMATE.
  - 4.) WATER LEVEL MEASUREMENTS OBTAINED ON OCTOBER 26, 1998.
  - 5.) ONLY WELL LOCATIONS WITH AN ELEVATION LISTED ARE USED IN MAP CONTOURING.
  - 6.) CONTOURS BETWEEN KNOWN POINTS HAVE BEEN INTERPOLATED.
  - 7.) TOTAL VOLATILE ORGANIC (TVO) DETECTIONS.

NOTE: NOT ALL CONTOURS LINES SHOWN DUE TO LINE DENSITY



		WAR 2 & 3 1998 NIAGARA FALLS, NEW YORK	
<b>TITLE</b> GROUNDWATER ELEVATION CONTOUR MAP ZONE 1 BEDROCK - OCTOBER 1998 Buffalo, New York			
DRAWN BY: BEC CHECKED BY: JPR DESIGNED BY: DCW APPROVED BY: ALG	DATE: 11/19/98 SCALE: 1"=300' JOB NO.: 973-915B SHEET NO.: BELL133	PREPARED BY: JPR DATE: 11/19/98	FILE NO.: 973-915B SHEET NO.: 5
REV.	DATE	DESCRIPTION	DR. BY

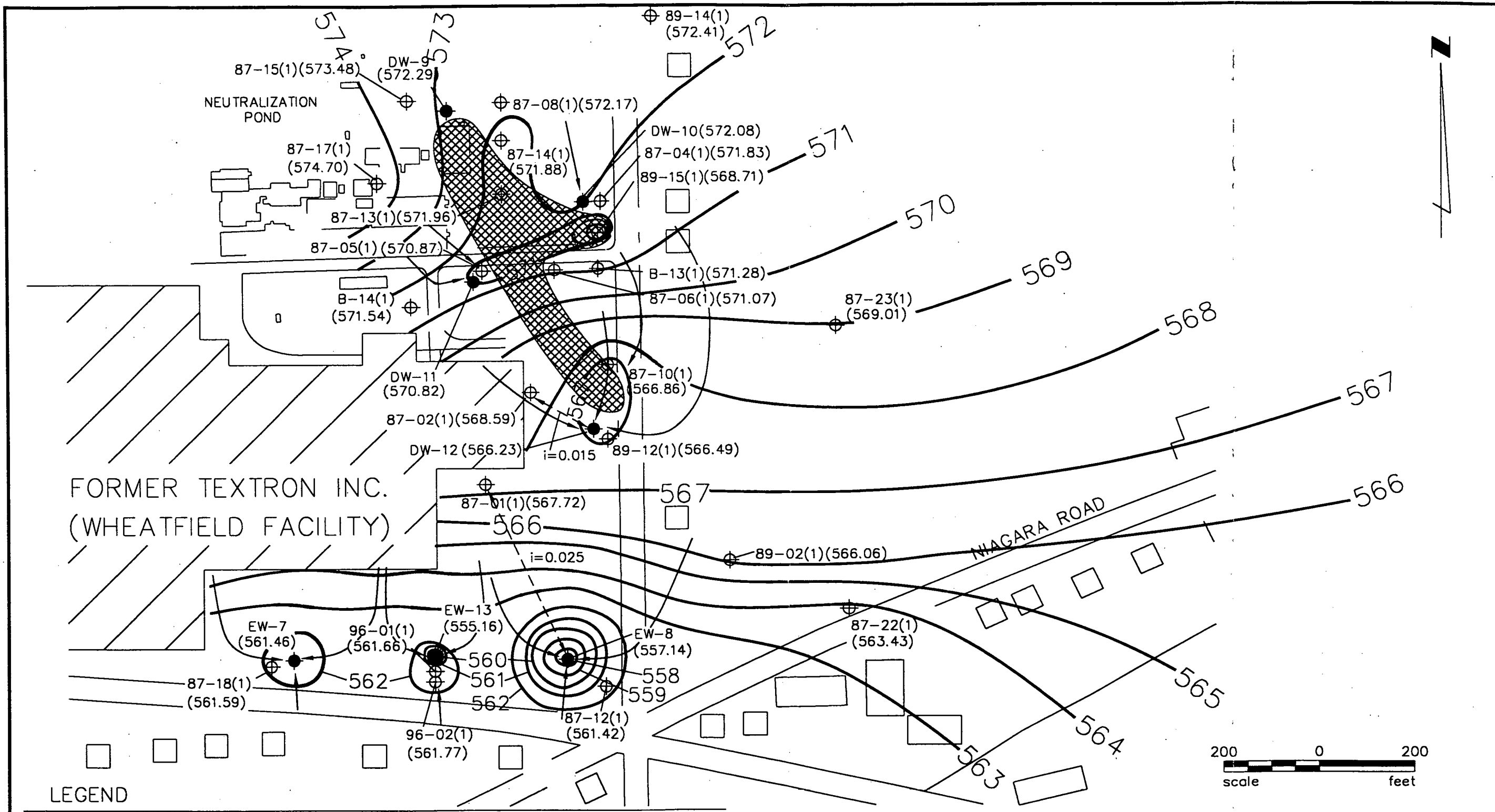

**LEGEND**

- EXTRACTION WELL OR DNAPL WELL
- ⊕ MONITORING WELL
- (564.88) WATER LEVEL ELEVATIONS AT MONITORING OR EXTRACTION WELL IN FEET MEAN SEA LEVEL.
- DIRECTION OF GROUND WATER FLOW IN ZONE 1
- i=0.025 HORIZONTAL HYDRAULIC GRADIENT (ft/ft)
- 569 — POTENTIOMETRIC ELEVATION CONTOUR IN FEET MEAN SEA LEVEL
- ▨ DNAPL PLUME

**Golder Associates** Buffalo, New York

CLIENT/PROJECT **TEXTRON** NIAGARA FALLS, NEW YORK

TITLE ON-SITE GROUNDWATER ELEVATION CONTOUR MAP, ZONE 1 BEDROCK OCTOBER 1998			
DRAWN	BEC	DATE	11/16/98
CHECKED	JPR	SCALE	AS SHOWN
REVIEWED	ALG	FILE NO.	973-9158
JOB NO.		973-9158	
DWG. NO.		BELL131	
FIGURE NO.		6	



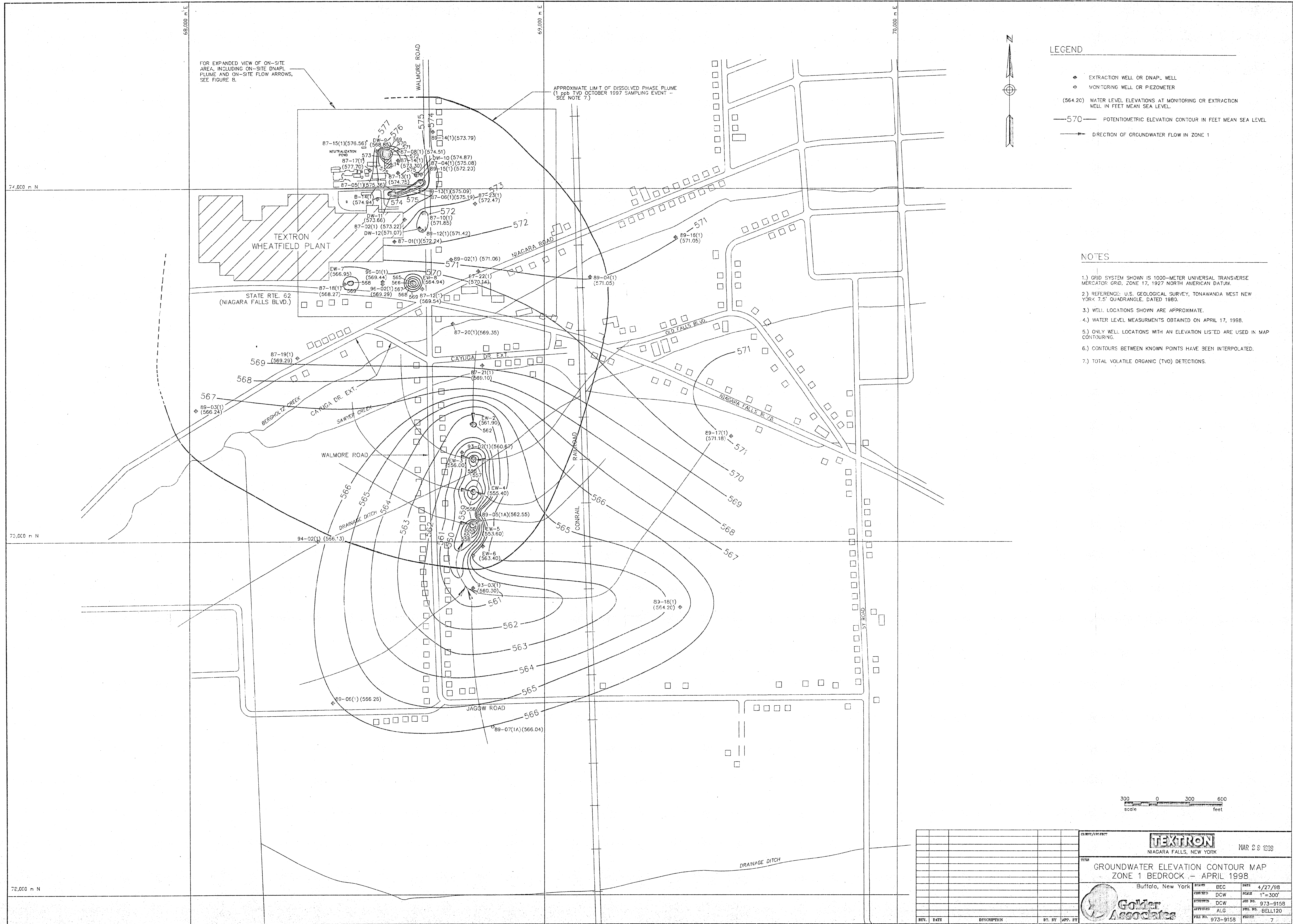

FOR EXPANDED VIEW OF ON-SITE AREA, INCLUDING ON-SITE DNAPL PLUME AND ON-SITE FLOW ARROWS, SEE FIGURE 8.

APPROXIMATE LIMIT OF DISSOLVED PHASE PLUME (1 ppb TVO OCTOBER 1997 SAMPLING EVENT - SEE NOTE 7.)

- LEGEND**
- ◆ EXTRACTION WELL OR DNAPL WELL
  - ⊕ MONITORING WELL OR PIEZOMETER
  - (564.20) WATER LEVEL ELEVATIONS AT MONITORING OR EXTRACTION WELL IN FEET MEAN SEA LEVEL
  - 570— POTENTIOMETRIC ELEVATION CONTOUR IN FEET MEAN SEA LEVEL
  - DIRECTION OF GROUNDWATER FLOW IN ZONE 1

- NOTES**
- 1.) GRID SYSTEM SHOWN IS 1000-METER UNIVERSAL TRANSVERSE MERCATOR GRID, ZONE 17, 1927 NORTH AMERICAN DATUM.
  - 2.) REFERENCE: U.S. GEOLOGICAL SURVEY, TONAWANDA WEST NEW YORK 7.5' QUADRANGLE, DATED 1980.
  - 3.) WELL LOCATIONS SHOWN ARE APPROXIMATE.
  - 4.) WATER LEVEL MEASUREMENTS OBTAINED ON APRIL 17, 1998.
  - 5.) ONLY WELL LOCATIONS WITH AN ELEVATION LISTED ARE USED IN MAP CONTOURING.
  - 6.) CONTOURS BETWEEN KNOWN POINTS HAVE BEEN INTERPOLATED.
  - 7.) TOTAL VOLATILE ORGANIC (TVO) DETECTIONS.

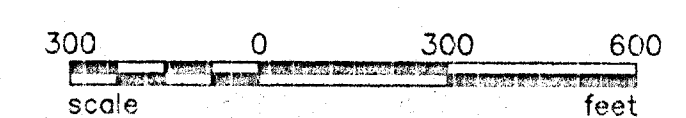

<b>TEXTRON</b> NIAGARA FALLS, NEW YORK		MAR 28 1998	
<b>GROUNDWATER ELEVATION CONTOUR MAP</b> ZONE 1 BEDROCK - APRIL 1998 Buffalo, New York			
DRAWN BY DCW	REC'D DCW	DATE 4/27/98	SCALE 1"=300'
APPROVED BY ALG	JOB NO. 973-9158	FILE NO. BELL20	SHEET NO. 7
REV. DATE DESCRIPTION	D. BY APP. BY		

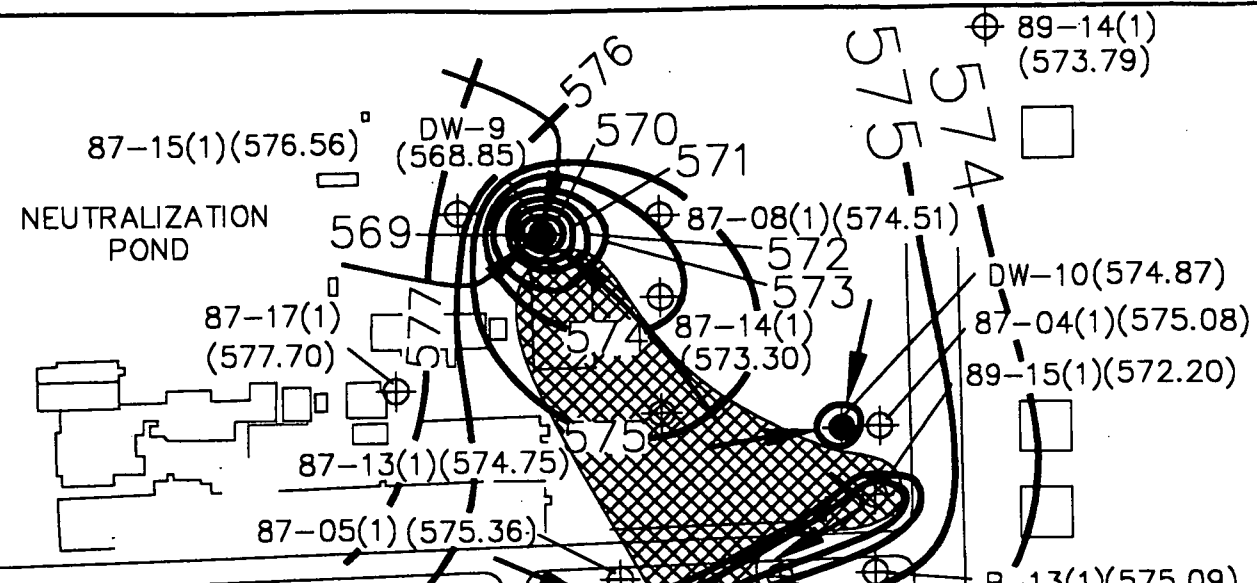

TEXTRON  
WHEATFIELD PLANT

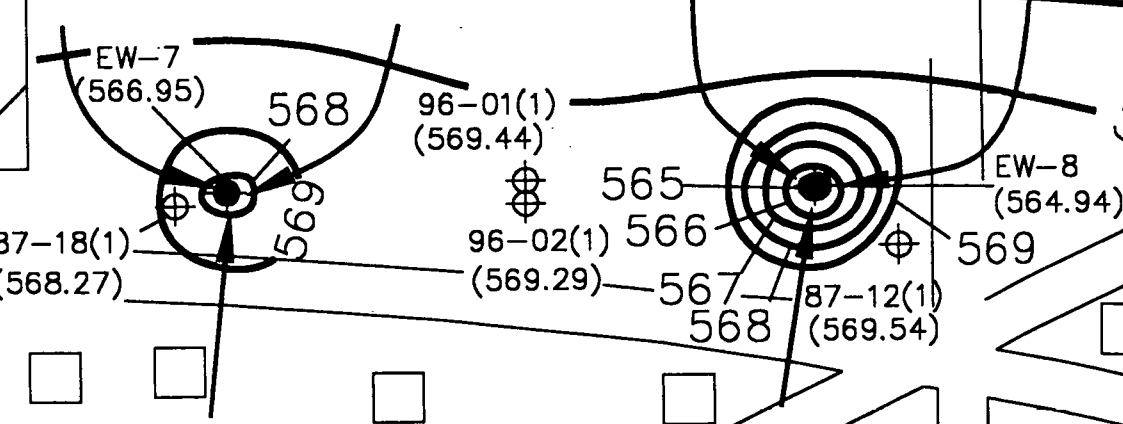

NIAGARA ROAD

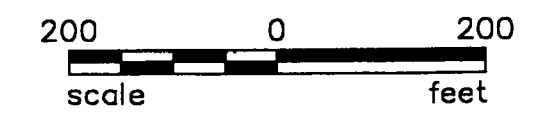

- LEGEND**
- EXTRACTION WELL OR DNAPL WELL
  - ⊕ MONITORING WELL
  - (569.10) WATER LEVEL ELEVATIONS AT MONITORING OR EXTRACTION WELL IN FEET MEAN SEA LEVEL.
  - DIRECTION OF GROUND WATER FLOW IN ZONE 1
  - 569 — POTENTIOMETRIC ELEVATION CONTOUR IN FEET MEAN SEA LEVEL
  - ▨ DNAPL PLUME

**Golder Associates** Buffalo, New York

CLIENT/PROJECT **TEXTRON**  
NIAGARA FALLS, NEW YORK

TITLE ON-SITE GROUNDWATER ELEVATION CONTOUR MAP, ZONE 1 BEDROCK APRIL 1998			
DRAWN	BEC	DATE	4/27/98
CHECKED	DCW	SCALE	AS SHOWN
REVIEWED	ALG	FILE NO.	973-9158
JOB NO.		973-9158	
DWG. NO.		BELL121	
FIGURE NO.		8	



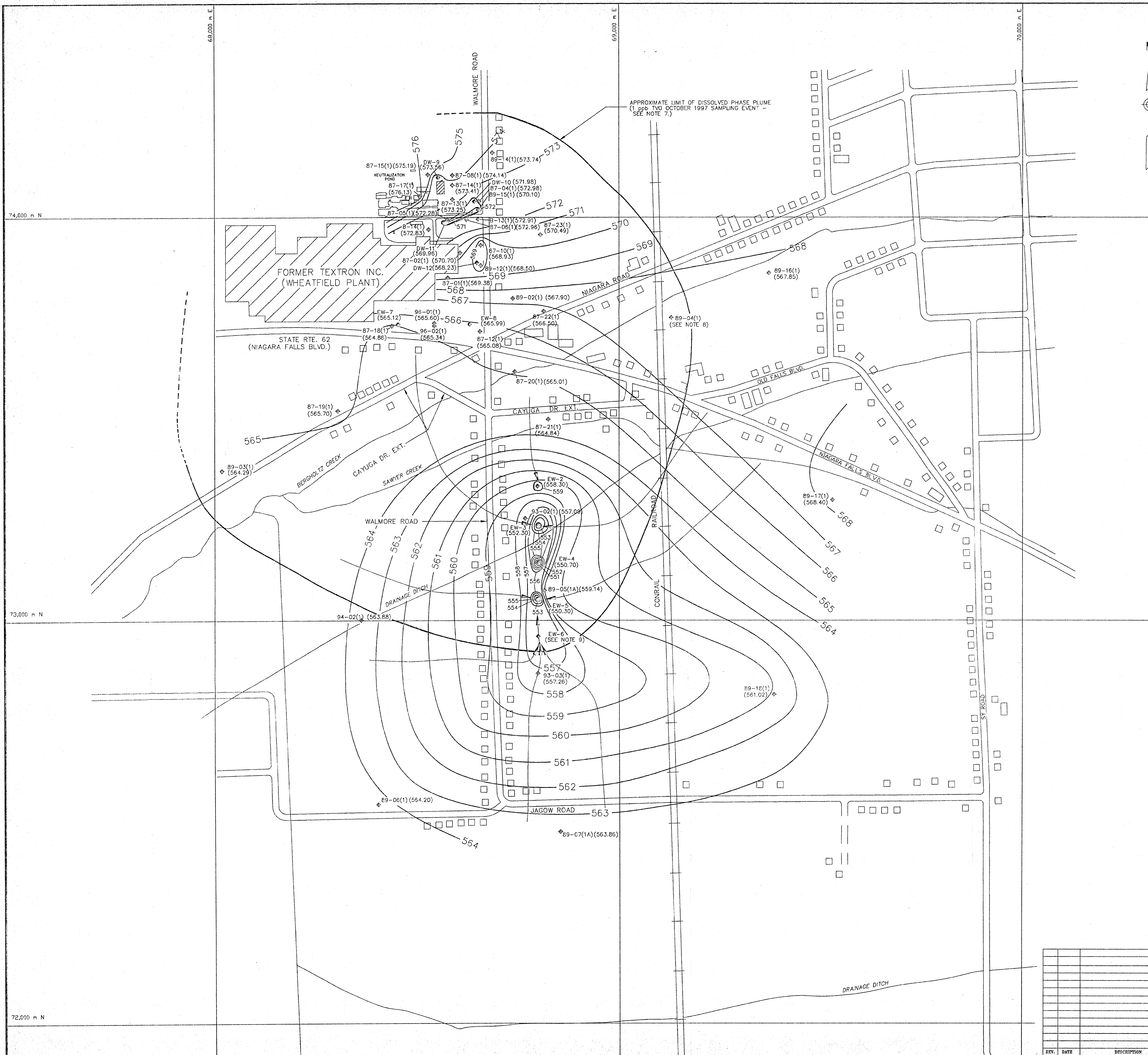

- LEGEND**
- ◆ EXTRACTION WELL OR DNAPL WELL
  - ⊕ MONITORING WELL OR PIEZOMETER
  - (567.85) WATER LEVEL ELEVATIONS AT MONITORING OR EXTRACTION WELL IN FEET MEAN SEA LEVEL
  - 570— POTENTIOMETRIC ELEVATION CONTOUR IN FEET MEAN SEA LEVEL
  - DIRECTION OF GROUNDWATER FLOW IN ZONE 1

- NOTES**
- 1.) GRID SYSTEM SHOWN IS 1000-METER UNIVERSAL TRANSVERSE MERCATOR GRID, ZONE 17, 1927 NORTH AMERICAN DATUM.
  - 2.) REFERENCE: U.S. GEOLOGICAL SURVEY, TONAWANDA WEST NEW YORK 7.5' QUADRANGLE, DATED 1980.
  - 3.) WELL LOCATIONS SHOWN ARE APPROXIMATE.
  - 4.) WATER LEVEL MEASUREMENTS OBTAINED ON JULY 24 AND 27, 1998.
  - 5.) ONLY WELL LOCATIONS WITH AN ELEVATION LISTED ARE USED IN MAP CONTOURING.
  - 6.) CONTOURS BETWEEN KNOWN POINTS HAVE BEEN INTERPOLATED.
  - 7.) TOTAL VOLATILE ORGANIC (TVO) DETECTIONS.
  - 8.) WATER LEVEL AT 89-04(1) NOT OBTAINED DUE TO BEES LOCATED IN WELL CASING.
  - 9.) WATER LEVEL AT EW-6 NOT OBTAINED DUE TO INOPERATEABLE VAULT READOUT.
  - 10.) EW-7, EW-8, AND DW-9 WERE OFFLINE DURING HYDRAULIC MONITORING.

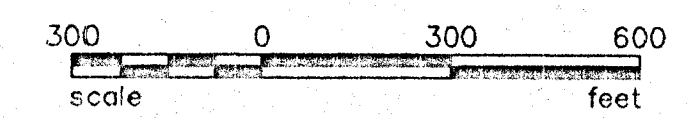

		MAR 29 1998	
NIAGARA FALLS, NEW YORK			
<b>TITLE</b> GROUNDWATER ELEVATION CONTOUR MAP ZONE 1 BEDROCK - JULY 1998			
Buffalo, New York		DRAWN BEC	DATE 9/17/98
		CHECKED JPR	SCALE 1"=300'
REVIEWED DCW		JOB NO. 973-0158	APPROVED ALG
FILE NO. 973-0158		SHEET NO. BELL123	PAGE 9

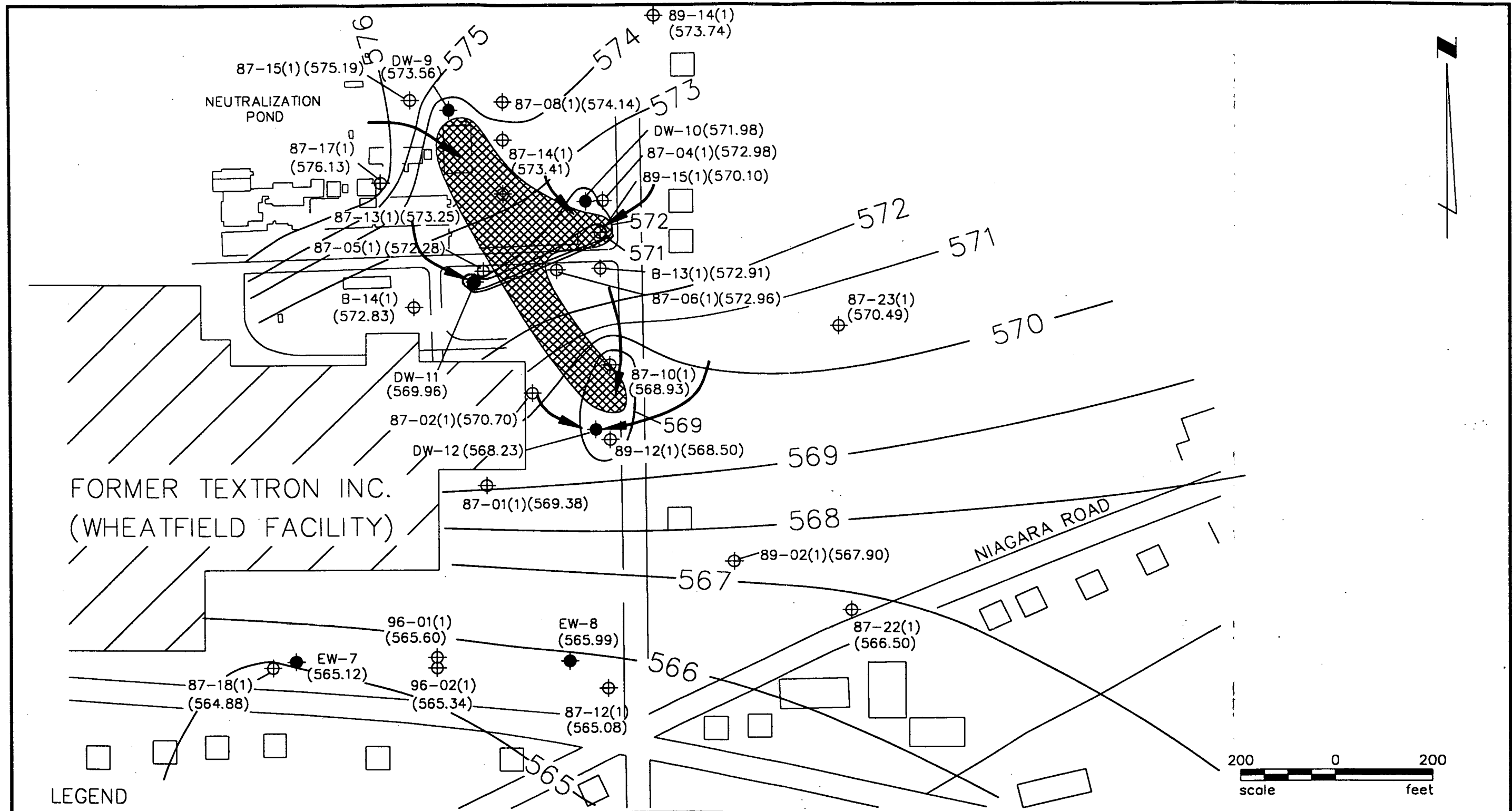

- LEGEND**
- EXTRACTION WELL OR DNAPL WELL
  - ⊕ MONITORING WELL
  - (564.88) WATER LEVEL ELEVATIONS AT MONITORING OR EXTRACTION WELL IN FEET MEAN SEA LEVEL.
  - DIRECTION OF GROUND WATER FLOW IN ZONE 1
  - 569 — POTENTIOMETRIC ELEVATION CONTOUR IN FEET MEAN SEA LEVEL
  - ▨ DNAPL PLUME

<b>Golder Associates</b> Buffalo, New York	<b>TITLE</b> ON-SITE GROUNDWATER ELEVATION CONTOUR MAP, ZONE 1 BEDROCK JULY 1998		
	<b>CLIENT/PROJECT</b> <b>TEXTRON</b> NIAGARA FALLS, NEW YORK	<b>DRAWN</b> BEC	<b>DATE</b> 9/1/98
	<b>CHECKED</b> JPR	<b>SCALE</b> AS SHOWN	<b>DWG. NO.</b> BELL124
	<b>REVIEWED</b> ALG	<b>FILE NO.</b> 973-9158	<b>FIGURE NO.</b> 10



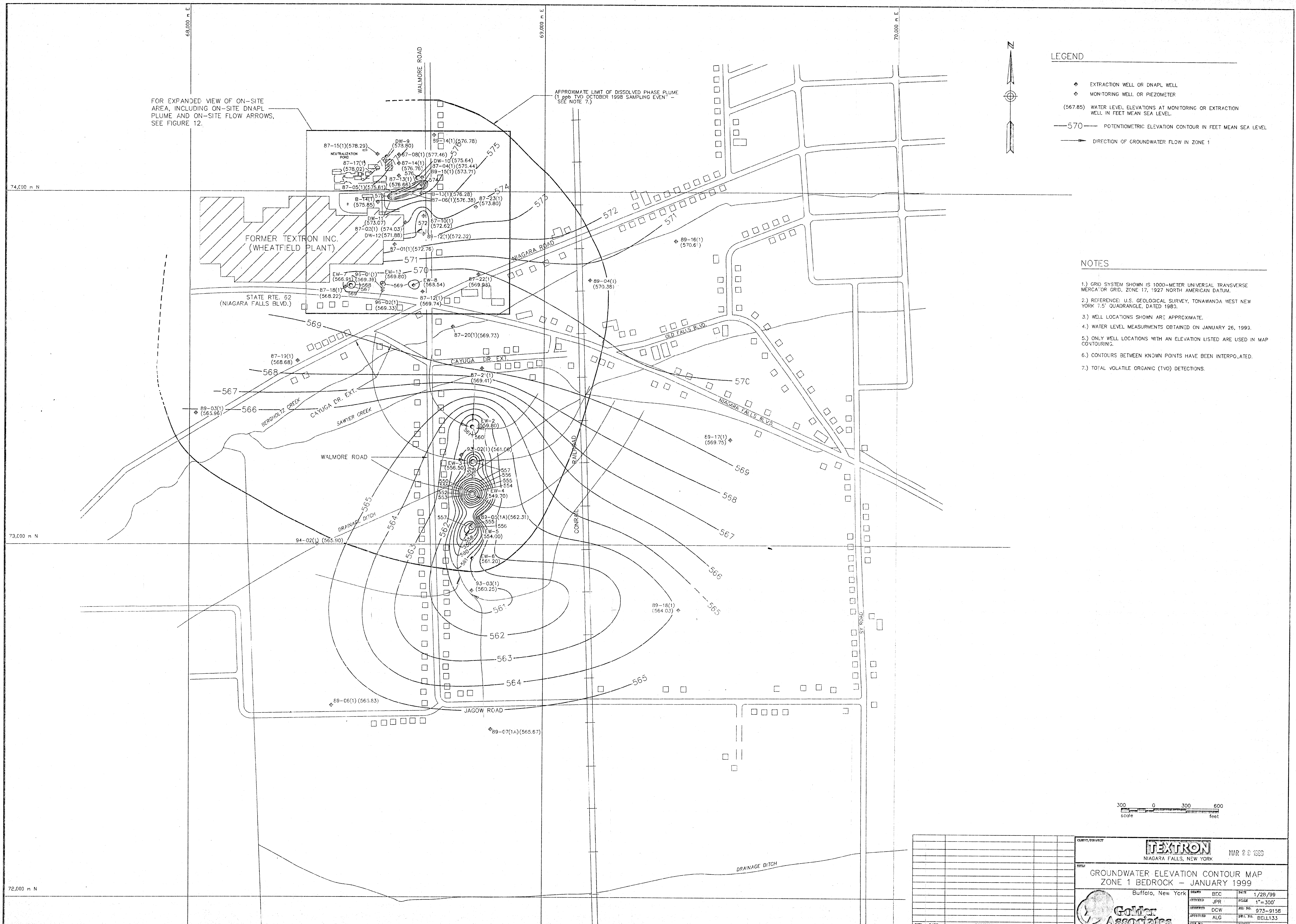

FOR EXPANDED VIEW OF ON-SITE AREA, INCLUDING ON-SITE DNAPL PLUME AND ON-SITE FLOW ARROWS, SEE FIGURE 12.

APPROXIMATE LIMIT OF DISSOLVED PHASE PLUME (1 ppb TVO OCTOBER 1998 SAMPLING EVENT - SEE NOTE 7.)

- LEGEND**
- ◆ EXTRACTION WELL OR DNAPL WELL
  - ◇ MONITORING WELL OR PIEZOMETER
  - (567.85) WATER LEVEL ELEVATIONS AT MONITORING OR EXTRACTION WELL IN FEET MEAN SEA LEVEL.
  - 570— POTENTIOMETRIC ELEVATION CONTOUR IN FEET MEAN SEA LEVEL
  - DIRECTION OF GROUNDWATER FLOW IN ZONE 1

- NOTES**
- 1.) GRID SYSTEM SHOWN IS 1000-METER UNIVERSAL TRANSVERSE MERCATOR GRID, ZONE 17, 1927 NORTH AMERICAN DATUM.
  - 2.) REFERENCE: U.S. GEOLOGICAL SURVEY, TONAWANDA WEST NEW YORK 7.5' QUADRANGLE, DATED 1980.
  - 3.) WELL LOCATIONS SHOWN ARE APPROXIMATE.
  - 4.) WATER LEVEL MEASUREMENTS OBTAINED ON JANUARY 26, 1999.
  - 5.) ONLY WELL LOCATIONS WITH AN ELEVATION LISTED ARE USED IN MAP CONTOURING.
  - 6.) CONTOURS BETWEEN KNOWN POINTS HAVE BEEN INTERPOLATED.
  - 7.) TOTAL VOLATILE ORGANIC (TVO) DETECTIONS.

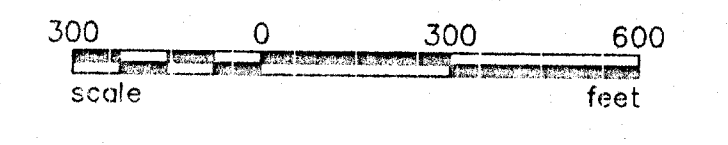

		MAR 20 1999	
<b>TITLE</b> GROUNDWATER ELEVATION CONTOUR MAP ZONE 1 BEDROCK - JANUARY 1999 Buffalo, New York			
	DRAWN BY BEC	DATE 1/28/99	
	CHECKED BY JPR	SCALE 1" = 300'	
	APPROVED BY DCW	JOB NO. 973-9158	
		DWN. NO. BELL133	
		FILE NO. 973-0158	
		SHEETS 11	

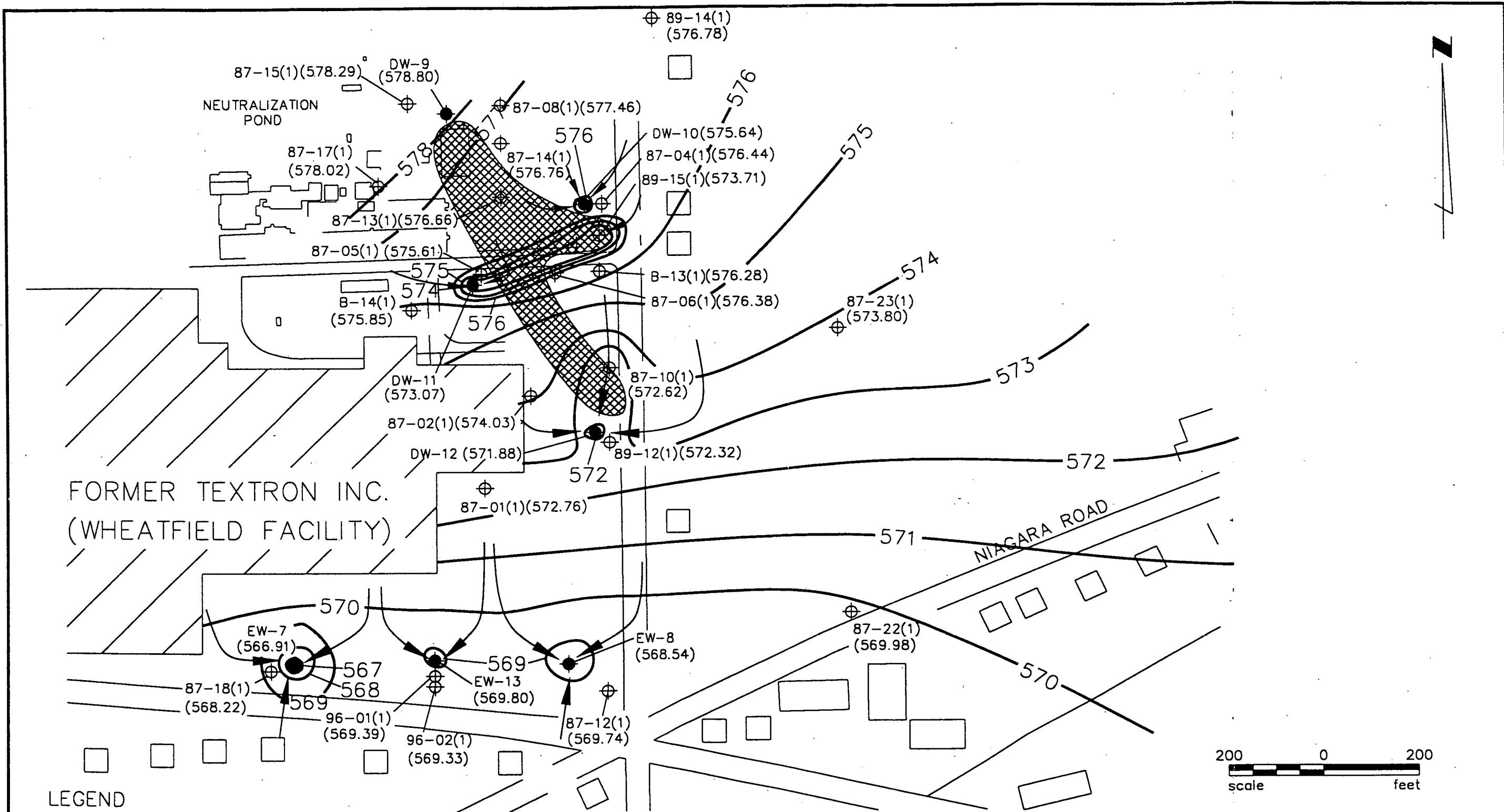

LEGEND

- EXTRACTION WELL OR DNAPL WELL
- ⊕ MONITORING WELL
- (569.74) WATER LEVEL ELEVATIONS AT MONITORING OR EXTRACTION WELL IN FEET MEAN SEA LEVEL.
- DIRECTION OF GROUND WATER FLOW IN ZONE 1
- 569 — POTENTIOMETRIC ELEVATION CONTOUR IN FEET MEAN SEA LEVEL
- ▨ DNAPL PLUME

**Golder Associates** Buffalo, New York  
 CLIENT/PROJECT **TEXTRON**  
 NIAGARA FALLS, NEW YORK

TITLE ON-SITE GROUNDWATER ELEVATION CONTOUR MAP, ZONE 1 BEDROCK JANUARY 1999			
DRAWN	BEC	DATE	1/28/99
CHECKED	JPR	SCALE	AS SHOWN
REVIEWED	ALG	FILE NO.	973-9158
JOB NO.		973-9158	
DWG. NO.		BELL134	
FIGURE NO.		12	

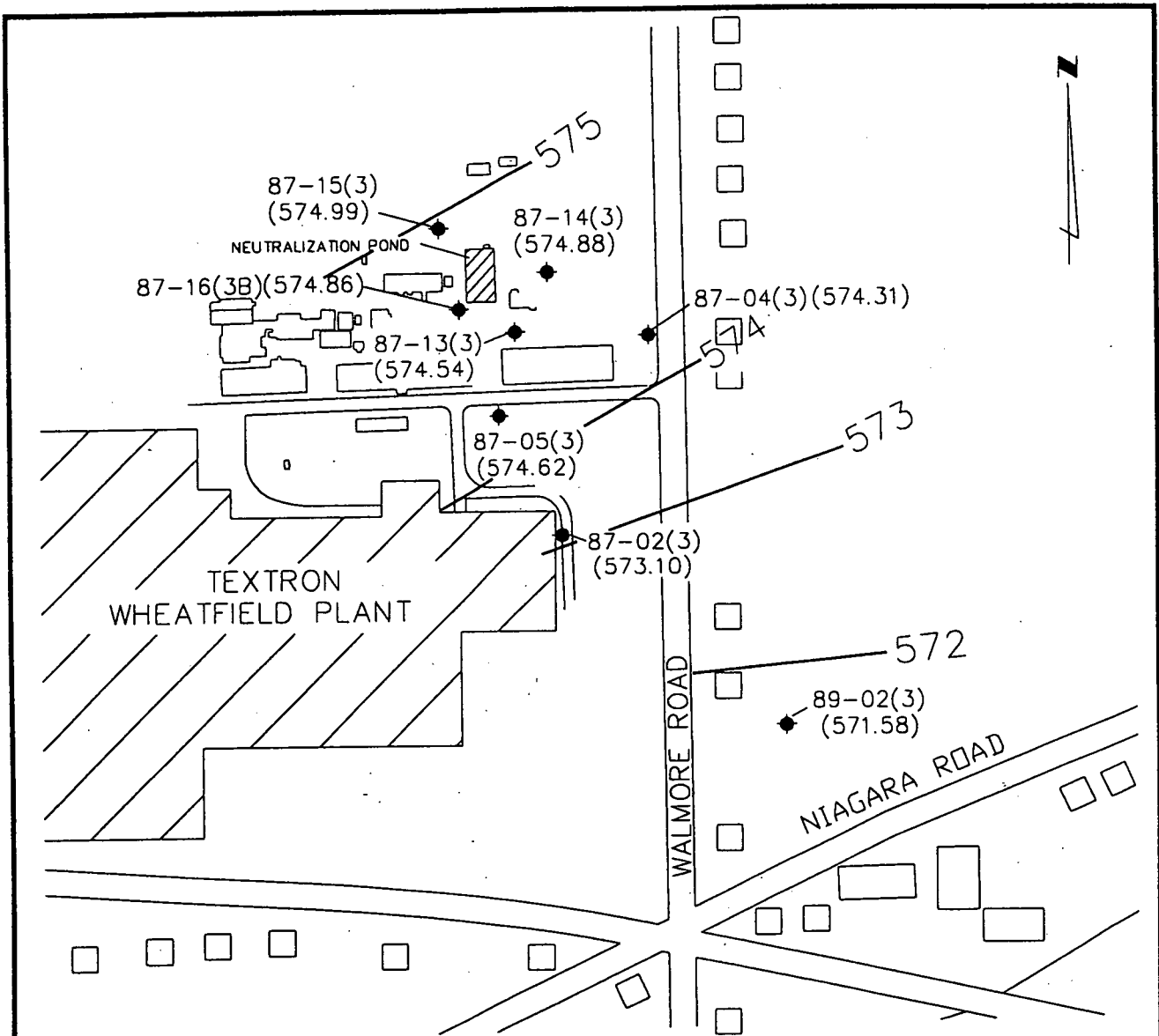

### LEGEND

◆ MONITORING WELL

(571.58) WATER LEVEL ELEVATIONS AT MONITORING WELL IN FEET MEAN SEA LEVEL.

—575— POTENTIOMETRIC ELEVATION CONTOUR IN FEET MEAN SEA LEVEL

➔ DIRECTION OF GROUND WATER FLOW IN ZONE 3

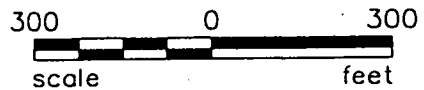

**Golder Associates** Buffalo, New York

CLIENT/PROJECT

**TEXTRON**

NIAGARA FALLS, NEW YORK

TITLE

ON-SITE GROUNDWATER ELEVATION CONTOUR MAP, ZONE 3 BEDROCK  
OCTOBER 1998

DRAWN	BEC	DATE	2/10/99	JOB NO.	973-9158
CHECKED	DCW	SCALE	AS SHOWN	DWG NO./REV. NO.	BELL135
REVIEWED	ALG	FILE NO.	973-9158	FIGURE NO.	13

APPENDIX A  
ANALYTICAL SAMPLING RESULTS



WELL NUMBER 87-01(0)  
ANALYTICAL SAMPLING RESULTS  
(Concentrations in ug/L)

ANALYTE	4/93	7/93	10/93	1/94	4/94	7/94	10/94	1/9/95	4/95	7/95	10/95	2/1/96	4/96	7/96	10/17/96
CHLOROMETHANE								0.5 U				0.5 U			0.5 U
VINYL CHLORIDE								0.5 U				0.5 U			0.5 U
CHLOROETHANE								0.5 U				0.5 U			0.5 U
BROMOMETHANE								0.5 U				0.5 U			0.5 U
1 1-DICHLOROETHENE								0.5 U				0.5 U			0.5 U
ACETONE								10 U				10 U			10 U
CARBON DISULFIDE								0.5 U				0.5 U			0.5 U
METHYLENE CHLORIDE								0.5 U				0.5 U			0.5 U
TRANS-1 2-DICHLOROETHENE								0.5 U				0.5 U			0.5 U
1 1-DICHLOROETHANE								0.5 U				0.5 U			0.5 U
CIS-1 2-DICHLOROETHENE								0.5 U				0.5 U			0.5 U
METHYL ETHYL KETONE								10 U				10 U			10 U
CHLOROFORM								0.5 U				0.5 U			0.5 U
1 1 1-TRICHLOROETHANE								0.5 U				0.5 U			0.5 U
CARBON TETRACHLORIDE								0.5 U				0.5 U			0.5 U
BENZENE								0.5 U				0.5 U			0.5 U
1 2-DICHLOROETHANE								0.5 U				0.5 U			0.5 U
TRICHLOROETHENE								0.5 U				0.5 U			0.5 U
1 2-DICHLOROPROPANE								0.5 U				0.5 U			0.5 U
BROMODICHLOROMETHANE								0.5 U				0.5 U			0.5 U
CIS-1 3-DICHLOROPROPENE								0.5 U				0.5 U			0.5 U
MIBK								10 U				10 U			10 U
TOLUENE								0.5 U				0.5 U			0.5 U
TRANS-1 3-DICHLOROPROPENE								0.5 U				0.5 U			0.5 U
1 1 2-TRICHLOROETHANE								0.5 U				0.5 U			0.5 U
TETRACHLOROETHENE								0.5 U				0.5 U			0.5 U
2-HEXANONE								10 U				10 U			10 U
DIBROMOCHLOROMETHANE								0.5 U				0.5 U			0.5 U
CHLOROBENZENE								0.5 U				0.5 U			0.5 U
ETHYLBENZENE								0.5 U				0.5 U			0.5 U
P-XYLENE/M-XYLENE								0.5 U				0.5 U			0.5 U
O-XYLENE								0.5 U				0.5 U			0.5 U
STYRENE								0.5 U				0.5 U			0.5 U
BROMOFORM								0.5 U				0.5 U			0.5 U
1 1 2 2-TETRACHLOROETHANE								0.5 U				1 U			0.5 U

**NOTES:**

U = Below Practical Quantitation Limit (PQL)

Blank = Not sampled

WELL NUMBER 87-01(0)  
ANALYTICAL SAMPLING RESULTS  
(Concentrations in ug/L)

ANALYTE	1/97	4/97	7/97	10/30/97	4/98	10/98	AVG
CHLOROMETHANE				0.5 U			0.0
VINYL CHLORIDE				0.5 U			0.0
CHLOROETHANE				0.5 U			0.0
BROMOMETHANE				0.5 U			0.0
1 1-DICHLOROETHENE				0.5 U			0.0
ACETONE				10 U			0.0
CARBON DISULFIDE				0.5 U			0.0
METHYLENE CHLORIDE				0.5 U			0.0
TRANS-1 2-DICHLOROETHENE				0.5 U			0.0
1 1-DICHLOROETHANE				0.5 U			0.0
CIS-1 2-DICHLOROETHENE				0.5 U			0.0
METHYL ETHYL KETONE				10 U			0.0
CHLOROFORM				0.5 U			0.0
1 1 1-TRICHLOROETHANE				0.5 U			0.0
CARBON TETRACHLORIDE				0.5 U			0.0
BENZENE				0.5 U			0.0
1 2-DICHLOROETHANE				0.5 U			0.0
TRICHLOROETHENE				1			0.3
1 2-DICHLOROPROPANE				0.5 U			0.0
BROMODICHLOROMETHANE				0.5 U			0.0
CIS-1 3-DICHLOROPROPENE				0.5 U			0.0
MIBK				10 U			0.0
TOLUENE				0.5 U			0.0
TRANS-1 3-DICHLOROPROPENE				0.5 U			0.0
1 1 2-TRICHLOROETHANE				0.5 U			0.0
TETRACHLOROETHENE				0.5 U			0.0
2-HEXANONE				10 U			0.0
DIBROMOCHLOROMETHANE				0.5 U			0.0
CHLOROBENZENE				0.5 U			0.0
ETHYLBENZENE				0.5 U			0.0
P-XYLENE/M-XYLENE				0.5 U			0.0
O-XYLENE				0.5 U			0.0
STYRENE				0.5 U			0.0
BROMOFORM				0.5 U			0.0
1 1 2 2-TETRACHLOROETHANE				0.5 U			0.0

## NOTES:

U = Below Practical Quantitation Limit (PQL)

Blank = Not sampled

WELL NUMBER 87-01(1)  
ANALYTICAL SAMPLING RESULTS  
(Concentrations in ug/L)

ANALYTE	4/93	7/93	10/93	1/94	4/94	7/94	10/94	1/9/95	4/95	7/95	10/95	2/1/96	4/96	7/96	10/17/96
CHLOROMETHANE								50 U				100 U			50 U
VINYL CHLORIDE								201				440			150
CHLOROETHANE								50 U				100 U			50 U
BROMOMETHANE								50 U				100 U			50 U
1 1-DICHLOROETHENE								50 U				100 U			50 U
ACETONE								500 U				810			250 U
CARBON DISULFIDE								50 U				100 U			50 U
METHYLENE CHLORIDE								842				100 U			50 U
TRANS-1 2-DICHLOROETHENE								50 U				100 U			50 U
1 1-DICHLOROETHANE								50 U				100 U			50 U
CIS-1 2-DICHLOROETHENE								2130				1600			920
METHYL ETHYL KETONE								500 U				810			250 U
CHLOROFORM								50 U				100 U			50 U
1 1 1-TRICHLOROETHANE								145				100 U			58
CARBON TETRACHLORIDE								50 U				100 U			50 U
BENZENE								50 U				100 U			50 U
1 2-DICHLOROETHANE								50 U				100 U			50 U
TRICHLOROETHENE								951				100 U			50 U
1 2-DICHLOROPROPANE								50 U				100 U			50 U
BROMODICHLOROMETHANE								50 U				100 U			50 U
CIS-1 3-DICHLOROPROPENE								50 U				100 U			50 U
MIBK								500 U				500 U			100 U
TOLUENE								50 U				100 U			50 U
TRANS-1 3-DICHLOROPROPENE								50 U				100 U			50 U
1 1 2-TRICHLOROETHANE								50 U				100 U			50 U
TETRACHLOROETHENE								50 U				100 U			50 U
2-HEXANONE								500 U				500 U			100 U
DIBROMOCHLOROMETHANE								50 U				100 U			50 U
CHLOROBENZENE								50 U				100 U			50 U
ETHYLBENZENE								50 U				100 U			50 U
P-XYLENE/M-XYLENE								50 U				100 U			50 U
O-XYLENE								50 U				100 U			50 U
STYRENE								50 U				100 U			50 U
BROMOFORM								50 U				100 U			50 U
1 1 2 2-TETRACHLOROETHANE								50 U				100 U			50 U

## NOTES:

U = Below Practical Quantitation Limit (PQL)

Blank = Not sampled

WELL NUMBER 87-01(1)  
ANALYTICAL SAMPLING RESULTS  
(Concentrations in ug/L)

ANALYTE	1/97	4/97	7/97	10/30/97	4/98	10/29/98	AVG
CHLOROMETHANE				0.5 U		130 U	0.0
VINYL CHLORIDE				170		170	226.2
CHLOROETHANE				0.5 U		130 U	0.0
BROMOMETHANE				0.5 U		130 U	0.0
1 1-DICHLOROETHENE				0.5 U		130 U	0.0
ACETONE				10 U		630 U	162.0
CARBON DISULFIDE				0.5 U		130 U	0.0
METHYLENE CHLORIDE				0.5 U		130 U	168.4
TRANS-1 2-DICHLOROETHENE				5		130 U	1.0
1 1-DICHLOROETHANE				20		130 U	4.0
CIS-1 2-DICHLOROETHENE				1700		1000	1470.0
METHYL ETHYL KETONE				10 U		630 U	162.0
CHLOROFORM				0.5 U		130 U	0.0
1 1 1-TRICHLOROETHANE				66		130 U	53.8
CARBON TETRACHLORIDE				0.5 U		130 U	0.0
BENZENE				0.5 U		130 U	0.0
1 2-DICHLOROETHANE				0.5 U		130 U	0.0
TRICHLOROETHENE				50		38 J	200.2
1 2-DICHLOROPROPANE				0.5 U		130 U	0.0
BROMODICHLOROMETHANE				0.5 U		130 U	0.0
CIS-1 3-DICHLOROPROPENE				0.5 U		130 U	0.0
MIBK				10 U		250 U	0.0
TOLUENE				1		130 U	0.2
TRANS-1 3-DICHLOROPROPENE				0.5 U		130 U	0.0
1 1 2-TRICHLOROETHANE				0.5 U		130 U	0.0
TETRACHLOROETHENE				0.5 U		130 U	0.0
2-HEXANONE				10 U		250 U	0.0
DIBROMOCHLOROMETHANE				0.5 U		130 U	0.0
CHLOROBENZENE				0.5 U		130 U	0.0
ETHYLBENZENE				0.5 U		130 U	0.0
P-XYLENE/M-XYLENE				0.6		130 U	0.1
O-XYLENE				0.5 U		130 U	0.0
STYRENE				0.5 U		130 U	0.0
BROMOFORM				0.5 U		130 U	0.0
1 1 2 2-TETRACHLOROETHANE				0.5 U		130 U	0.0

**NOTES:**

U = Below Practical Quantitation Limit (PQL)

Blank = Not sampled

WELL NUMBER 87-02(1)  
ANALYTICAL SAMPLING RESULTS  
(Concentrations in ug/L)

ANALYTE	4/93	7/93	10/93	1/94	4/27/94	7/21/94	10/26/94	1/11/95	4/20/95	7/12/95	10/19/95	2/1/96	4/18/96
CHLOROMETHANE					5 U	125 U	125 U	100 U	1000 U	50 U	25 U	50 U	250 U
VINYL CHLORIDE					73	125 U	125 U	252	1000 U	50 U	25 U	300	250 U
CHLOROETHANE					5 U	125 U	125 U	100 U	1000 U	50 U	25 U	50 U	250 U
BROMOMETHANE					5 U	125 U	125 U	100 U	1000 U	50 U	25 U	50 U	250 U
1 1-DICHLOROETHENE					5 U	125 U	125 U	100 U	1000 U	50 U	25 U	50 U	250 U
ACETONE					50 U	1250 U	1250 U	1000 U	10000 U	500 U	250 U	250 U	1250 U
CARBON DISULFIDE					5 U	125 U	125 U	100 U	1000 U	50 U	25 U	50 U	250 U
METHYLENE CHLORIDE					9880	125 U	828	16800	1000 U	50 U	25 U	820	250 U
TRANS-1 2-DICHLOROETHENE					15	125 U	125 U	100 U	1000 U	50 U	25 U	50 U	250 U
1 1-DICHLOROETHANE					23	125 U	125 U	100 U	1000 U	50 U	25 U	50 U	250 U
CIS-1 2-DICHLOROETHENE					1640	658	1830	7250	7010	510	370	6800	2000
METHYL ETHYL KETONE					50 U	1250 U	1250 U	1000 U	10000 U	500 U	250 U	250 U	1250 U
CHLOROFORM					6	125 U	125 U	100 U	1000 U	50 U	25 U	50 U	250 U
1 1 1-TRICHLOROETHANE					624	125 U	125 U	817	1000 U	50 U	25 U	250	250 U
CARBON TETRACHLORIDE					5 U	125 U	125 U	100 U	1000 U	50 U	25 U	50 U	250 U
BENZENE					5 U	125 U	125 U	100 U	1000 U	50 U	25 U	50 U	250 U
1 2-DICHLOROETHANE					5 U	125 U	125 U	100 U	1000 U	50 U	25 U	50 U	250 U
TRICHLOROETHENE					13800	941	1540	20000	10000	620	130	4000	910
1 2-DICHLOROPROPANE					5 U	125 U	125 U	100 U	1000 U	50 U	25 U	50 U	250 U
BROMODICHLOROMETHANE					5 U	125 U	125 U	100 U	1000 U	50 U	25 U	50 U	250 U
CIS-1 3-DICHLOROPROPENE					5 U	125 U	125 U	100 U	1000 U	50 U	25 U	50 U	250 U
MIBK					50 U	1250 U	1250 U	1000 U	10000 U	500 U	250 U	250 U	500 U
TOLUENE					6	125 U	125 U	100 U	1000 U	50 U	25 U	50 U	250 U
TRANS-1 3-DICHLOROPROPENE					5 U	125 U	125 U	100 U	1000 U	50 U	25 U	50 U	250 U
1 1 2-TRICHLOROETHANE					5 U	125 U	125 U	100 U	1000 U	50 U	25 U	50 U	250 U
TETRACHLOROETHENE					5 U	125 U	125 U	100 U	1000 U	50 U	25 U	50 U	250 U
2-HEXANONE					50 U	1250 U	1250 U	1000 U	10000 U	500 U	250 U	250 U	500 U
DIBROMOCHLOROMETHANE					5 U	125 U	125 U	100 U	1000 U	50 U	25 U	50 U	250 U
CHLOROBENZENE					5 U	125 U	125 U	100 U	1000 U	50 U	25 U	50 U	250 U
ETHYLBENZENE					5 U	125 U	125 U	100 U	1000 U	50 U	25 U	50 U	250 U
P-XYLENE/M-XYLENE					5 U	125 U	125 U	100 U	1000 U	50 U	26	50 U	250 U
O-XYLENE					5 U	125 U	125 U	100 U	1000 U	50 U	25 U	50 U	250 U
STYRENE					5 U	125 U	125 U	100 U	1000 U	50 U	25 U	50 U	250 U
BROMOFORM					5 U	125 U	125 U	100 U	1000 U	50 U	25 U	50 U	250 U
1 1 2 2-TETRACHLOROETHANE					5 U	125 U	125 U	100 U	1000 U	50 U	25 U	50 U	250 U

**NOTES:**

U = Below Practical Quantitation Limit (PQL)

Blank = Not sampled

WELL NUMBER 87-02(1)  
ANALYTICAL SAMPLING RESULTS  
(Concentrations in ug/L)

ANALYTE	7/17/96	10/17/96	1/15/97	4/30/97	7/23/97	10/30/97	4/98	10/29/98	AVG
CHLOROMETHANE	25 U	25 U	5 U	0.5 U	0.5 U	25 U		25 U	0.0
VINYL CHLORIDE	25 U	25 U	8	15	160	25 U		20 J	50.5
CHLOROETHANE	25 U	25 U	5 U	0.5 U	0.5 U	25 U		25 U	0.0
BROMOMETHANE	25 U	25 U	5 U	0.5 U	0.5 U	25 U		25 U	0.0
1 1-DICHLOROETHENE	25 U	25 U	5 U	0.9	10	25 U		25 U	0.7
ACETONE	125 U	120 U	25 U	10 U	10 U	120 U		130 U	0.0
CARBON DISULFIDE	25 U	25 U	5 U	0.5 U	0.5 U	25 U		25 U	0.0
METHYLENE CHLORIDE	25 U	25 U	5 U	0.5 U	0.7	25 U		25 U	1770.5
TRANS-1 2-DICHLOROETHENE	25 U	25 U	5 U	4	19	25 U		25 U	2.4
1 1-DICHLOROETHANE	25 U	25 U	5 U	2	9	25 U		8 J	2.1
CIS-1 2-DICHLOROETHENE	340	350	170	250	3400	300		360	2077.4
METHYL ETHYL KETONE	125 U	120 U	25 U	10 U	10 U	120 U		130 U	0.0
CHLOROFORM	25 U	25 U	5 U	3	4	25 U		25 U	0.8
1 1 1-TRICHLOROETHANE	25 U	25 U	8	6	38	25 U		20 J	108.9
CARBON TETRACHLORIDE	25 U	25 U	5 U	0.5 U	0.5 U	25 U		25 U	0.0
BENZENE	25 U	25 U	5 U	0.5 U	0.5 U	25 U		25 U	0.0
1 2-DICHLOROETHANE	25 U	25 U	5 U	0.5 U	0.5 U	25 U		25 U	0.0
TRICHLOROETHENE	320	220	130	190	1100	230		300	3401.9
1 2-DICHLOROPROPANE	25 U	25 U	5 U	0.5 U	0.5 U	25 U		25 U	0.0
BROMODICHLOROMETHANE	25 U	25 U	5 U	0.5 U	0.5 U	25 U		25 U	0.0
CIS-1 3-DICHLOROPROPENE	25 U	25 U	5 U	0.5 U	0.5 U	25 U		25 U	0.0
MIBK	50 U	50 U	10 U	10 U	10 U	50 U		50 U	0.0
TOLUENE	25 U	25 U	5 U	0.5 U	2	25 U		25 U	0.5
TRANS-1 3-DICHLOROPROPENE	25 U	25 U	5 U	0.5 U	0.5 U	25 U		25 U	0.0
1 1 2-TRICHLOROETHANE	25 U	25 U	5 U	0.5 U	0.5 U	25 U		25 U	0.0
TETRACHLOROETHENE	25 U	25 U	5 U	0.5 U	0.5 U	25 U		25 U	0.0
2-HEXANONE	50 U	50 U	10 U	10 U	10 U	50 U		50 U	0.0
DIBROMOCHLOROMETHANE	25 U	25 U	5 U	0.5 U	0.5 U	25 U		25 U	0.0
CHLOROBENZENE	25 U	25 U	5 U	0.5 U	0.5 U	25 U		25 U	0.0
ETHYLBENZENE	25 U	25 U	5 U	0.5 U	0.5 U	25 U		25 U	0.0
P-XYLENE/M-XYLENE	25 U	25 U	5 U	0.5 U	0.5 U	25 U		25 U	1.6
O-XYLENE	25 U	25 U	5 U	0.5 U	0.5 U	25 U		25 U	0.0
STYRENE	25 U	25 U	5 U	0.5 U	0.5 U	25 U		25 U	0.0
BROMOFORM	25 U	25 U	5 U	0.5 U	0.5 U	25 U		25 U	0.0
1 1 2 2-TETRACHLOROETHANE	25 U	25 U	5 U	0.5 U	0.5 U	25 U		25 U	0.0

## NOTES:

U = Below Practical Quantitation Limit (PQL)

Blank = Not sampled

WELL NUMBER 87-02(3)  
ANALYTICAL SAMPLING RESULTS  
(Concentrations in ug/L)

ANALYTE	4/93	7/93	10/93	1/94	4/27/94	7/21/94	10/26/94	1/11/95	4/20/95	7/11/95	10/19/95	2/1/96	4/18/96
CHLOROMETHANE					0.5 U	1 U	1 U	0.5 U	1 U	1 U	1 U	0.5 U	0.5 U
VINYL CHLORIDE					0.5 U	1 U	1 U	0.5 U	1 U	1 U	1 U	1 U	0.5 U
CHLOROETHANE					0.5 U	1 U	1 U	0.5 U	1 U	1 U	1 U	0.5 U	0.5 U
BROMOMETHANE					0.5 U	1 U	1 U	0.5 U	1 U	1 U	1 U	0.5 U	0.5 U
1 1-DICHLOROETHENE					0.5 U	1 U	1 U	0.5 U	1 U	1 U	1 U	0.5 U	0.5 U
ACETONE					10 U	10 U	10 U	10 U	10 U	10	10 U	0.5 U	10 U
CARBON DISULFIDE					1	1 U	1 U	2	1 U	1	1 U	1	2
METHYLENE CHLORIDE					0.5 U	1 U	1 U	0.5 U	1 U	1 U	1 U	0.5 U	0.5 U
TRANS-1 2-DICHLOROETHENE					0.5 U	1 U	1 U	0.5 U	1 U	1 U	1 U	0.5 U	0.5 U
1 1-DICHLOROETHANE					0.5 U	1 U	1 U	0.5 U	1 U	1 U	1 U	0.5 U	0.5 U
CIS-1 2-DICHLOROETHENE					0.5 U	1 U	1 U	0.5 U	1 U	1 U	1 U	0.5 U	0.5 U
METHYL ETHYL KETONE					10 U	10 U	10 U	10 U	10 U	10 U	10 U	10 U	10 U
CHLOROFORM					0.5 U	1 U	1 U	0.5 U	1 U	1 U	1 U	0.5 U	0.5 U
1 1 1-TRICHLOROETHANE					0.5 U	1 U	1 U	0.5 U	1 U	1 U	1 U	0.5 U	0.5 U
CARBON TETRACHLORIDE					0.5 U	1 U	1 U	0.5 U	1 U	1 U	1 U	0.5 U	0.5 U
BENZENE					0.5 U	1 U	1 U	0.5 U	1 U	1 U	1 U	0.5 U	0.5 U
1 2-DICHLOROETHANE					0.5 U	1 U	1 U	0.5 U	1 U	1 U	1 U	0.5 U	0.5 U
TRICHLOROETHENE					0.5 U	1 U	1 U	0.5 U	1 U	1 U	1 U	0.5 U	0.5 U
1 2-DICHLOROPROPANE					0.5 U	1 U	1 U	0.5 U	1 U	1 U	1 U	0.5 U	0.5 U
BROMODICHLOROMETHANE					0.5 U	1 U	1 U	0.5 U	1 U	1 U	1 U	0.5 U	0.5 U
CIS-1 3-DICHLOROPROPENE					0.5 U	1 U	1 U	0.5 U	1 U	1 U	1 U	0.5 U	0.5 U
MIBK					10 U	10 U	10 U	10 U	10 U	10 U	10 U	10 U	10 U
TOLUENE					0.5 U	1 U	1 U	0.5 U	1 U	1 U	1 U	0.5 U	0.5 U
TRANS-1 3-DICHLOROPROPENE					0.5 U	1 U	1 U	0.5 U	1 U	1 U	1 U	0.5 U	0.5 U
1 1 2-TRICHLOROETHANE					0.5 U	1 U	1 U	0.5 U	1 U	1 U	1 U	0.5 U	0.5 U
TETRACHLOROETHENE					0.5 U	1 U	1 U	0.5 U	1 U	1 U	1 U	0.5 U	0.5 U
2-HEXANONE					10 U	10 U	10 U	10 U	10 U	10 U	10 U	10 U	10 U
DIBROMOCHLOROMETHANE					0.5 U	1 U	1 U	0.5 U	1 U	1 U	1 U	0.5 U	0.5 U
CHLOROBENZENE					0.5 U	1 U	1 U	0.5 U	1 U	1 U	1 U	0.5 U	0.5 U
ETHYLBENZENE					0.5 U	1 U	1 U	0.5 U	1 U	1 U	1 U	0.5 U	0.5 U
P-XYLENE/M-XYLENE					0.5 U	1 U	1 U	0.5 U	1 U	1 U	1 U	0.5 U	0.5 U
O-XYLENE					0.5 U	1 U	1 U	0.5 U	1 U	1 U	1 U	0.5 U	0.5 U
STYRENE					0.5 U	1 U	1 U	0.5 U	1 U	1 U	1 U	0.5 U	0.5 U
BROMOFORM					0.5 U	1 U	1 U	0.5 U	1 U	1 U	1 U	0.5 U	0.5 U
1 1 2 2-TETRACHLOROETHANE					0.5 U	1 U	1 U	0.5 U	1 U	1 U	1 U	1 U	1 U

## NOTES:

U = Below Practical Quantitation Limit (PQL)

Blank = Not sampled

WELL NUMBER 87-02(3)  
 ANALYTICAL SAMPLING RESULTS  
 (Concentrations in ug/L)

ANALYTE	7/17/96	10/17/96	1/15/97	4/30/97	7/23/97	10/30/97	4/20/98	10/29/98	AVG
CHLOROMETHANE	0.5 U	0.5 U	0.5 U	0.5 U	0.5 U	0.5 U	1 U	5 U	0.0
VINYL CHLORIDE	0.5 U	0.5 U	0.5 U	0.5 U	0.5 U	0.5 U	1 U	5 U	0.0
CHLOROETHANE	0.5 U	0.5 U	0.5 U	0.5 U	0.5 U	0.5 U	1 U	5 U	0.0
BROMOMETHANE	0.5 U	0.5 U	0.5 U	0.5 U	0.5 U	0.5 U	1 U	5 U	0.0
1 1-DICHLOROETHENE	0.5 U	0.5 U	0.5 U	0.5 U	0.5 U	0.5 U	1 U	5 U	0.0
ACETONE	10 U	10 U	10 U	10 U	10 U	10 U	10 U	25 U	0.6
CARBON DISULFIDE	1	3	1	1	1	0.7	5	5 U	1.2
METHYLENE CHLORIDE	0.5 U	0.5 U	0.5 U	0.5 U	0.5 U	0.5 U	2 U	5 U	0.0
TRANS-1 2-DICHLOROETHENE	0.5 U	0.5 U	0.5 U	0.5 U	0.5 U	0.5 U	1 U	5 U	0.0
1 1-DICHLOROETHANE	0.5 U	0.5 U	0.5 U	0.5 U	0.5 U	0.5 U	1 U	5 U	0.0
CIS-1 2-DICHLOROETHENE	0.5 U	0.5 U	0.5 U	0.5 U	0.5 U	0.5 U	1 U	5 U	0.0
METHYL ETHYL KETONE	10 U	10 U	10 U	10 U	10 U	10 U	10 U	25 U	0.0
CHLOROFORM	0.5 U	0.5 U	0.5 U	0.5 U	0.5 U	0.5 U	1 U	5 U	0.0
1 1 1-TRICHLOROETHANE	0.5 U	0.5 U	0.5 U	0.5 U	0.5 U	0.5 U	1 U	5 U	0.0
CARBON TETRACHLORIDE	0.5 U	0.5 U	0.5 U	0.5 U	0.5 U	0.5 U	1 U	5 U	0.0
BENZENE	0.5 U	0.5 U	0.5 U	0.5 U	0.6	0.5 U	0.7 U	5 U	0.0
1 2-DICHLOROETHANE	0.5 U	0.5 U	0.5 U	0.5 U	0.5 U	0.5 U	1 U	5 U	0.0
TRICHLOROETHENE	0.5 U	0.5 U	0.5 U	0.5 U	0.5 U	0.5 U	1 U	5 U	0.0
1 2-DICHLOROPROPANE	0.5 U	0.5 U	0.5 U	0.5 U	0.5 U	0.5 U	1 U	5 U	0.0
BROMODICHLOROMETHANE	0.5 U	0.5 U	0.5 U	0.5 U	0.5 U	0.5 U	1 U	5 U	0.0
CIS-1 3-DICHLOROPROPENE	0.5 U	0.5 U	0.5 U	0.5 U	0.5 U	0.5 U	1 U	5 U	0.0
MIBK	10 U	10 U	10 U	10 U	10 U	10 U	10 U	10 U	0.0
TOLUENE	0.5 U	0.5 U	0.5 U	0.5 U	0.5 U	0.5 U	1 U	5 U	0.0
TRANS-1 3-DICHLOROPROPENE	0.5 U	0.5 U	0.5 U	0.5 U	0.5 U	0.5 U	1 U	5 U	0.0
1 1 2-TRICHLOROETHANE	0.5 U	0.5 U	0.5 U	0.5 U	0.5 U	0.5 U	1 U	5 U	0.0
TETRACHLOROETHENE	0.5 U	0.5 U	0.5 U	0.5 U	0.5 U	0.5 U	1 U	5 U	0.0
2-HEXANONE	10 U	10 U	10 U	10 U	10 U	10 U	10 U	10 U	0.0
DIBROMOCHLOROMETHANE	0.5 U	0.5 U	0.5 U	0.5 U	0.5 U	0.5 U	1 U	5 U	0.0
CHLORO BENZENE	0.5 U	0.5 U	0.5 U	0.5 U	0.5 U	0.5 U	1 U	5 U	0.0
ETHYLBENZENE	0.5 U	0.5 U	0.5 U	0.5 U	0.5 U	0.5 U	1 U	5 U	0.0
P-XYLENE/M-XYLENE	0.5 U	0.5 U	0.5 U	0.5 U	0.5 U	0.5 U	1 U	5 U	0.0
O-XYLENE	0.5 U	0.5 U	0.5 U	0.5 U	0.5 U	0.5 U	1 U	5 U	0.0
STYRENE	0.5 U	0.5 U	0.5 U	0.5 U	0.5 U	0.5 U	1 U	5 U	0.0
BROMOFORM	0.5 U	0.5 U	0.5 U	0.5 U	0.5 U	0.5 U	1 U	5 U	0.0
1 1 2 2-TETRACHLOROETHANE	1 U	0.5 U	0.5 U	0.5 U	0.5 U	0.5 U	1 U	5 U	0.0

NOTES:

U = Below Practical Quantitation Limit (PQL)

Blank = Not sampled



WELL NUMBER 87-08(1)  
 ANALYTICAL SAMPLING RESULTS  
 (Concentrations in ug/L)

ANALYTE	4/93	7/93	10/93	1/94	4/28/94	7/21/94	10/25/94	1/12/95	4/20/95	7/12/95	10/19/95	2/1/96	4/17/96
CHLOROMETHANE					5 U	25 U	25 U	50 U	500 U	5 U	100 U	50 U	50 U
VINYL CHLORIDE					42	30	150	72	662	72	100 U	76	100
CHLOROETHANE					5 U	25 U	25 U	50 U	500 U	5 U	100 U	50 U	50 U
BROMOMETHANE					5 U	25 U	25 U	50 U	500 U	5 U	100 U	50 U	50 U
1 1-DICHLOROETHENE					5 U	25 U	25 U	50 U	500 U	5 U	100 U	50 U	50 U
ACETONE					50 U	250 U	250 U	500 U	5000 U	50 U	1000 U	260	250 U
CARBON DISULFIDE					5 U	25 U	25 U	50 U	500 U	5 U	100 U	50 U	50 U
METHYLENE CHLORIDE					5 U	25 U	25 U	50 U	500 U	5 U	220	50 U	790
TRANS-1 2-DICHLOROETHENE					10	25 U	25 U	50 U	500 U	5 U	100 U	50 U	50 U
1 1-DICHLOROETHANE					5 U	25 U	25 U	50 U	500 U	5 U	100 U	50 U	50 U
CIS-1 2-DICHLOROETHENE					684	523	1340	1160	12600	1090	1400	1200	950
METHYL ETHYL KETONE					50 U	250 U	250 U	500 U	5000 U	50 U	1000 U	250 U	250 U
CHLOROFORM					5 U	25 U	25 U	50 U	500 U	5 U	100 U	50 U	50 U
1 1 1-TRICHLOROETHANE					5 U	25 U	25 U	50 U	500 U	5 U	100 U	50 U	50 U
CARBON TETRACHLORIDE					5 U	25 U	25 U	50 U	500 U	5 U	100 U	50 U	50 U
BENZENE					5 U	25 U	25 U	50 U	500 U	5 U	100 U	50 U	50 U
1 2-DICHLOROETHANE					5 U	25 U	25 U	50 U	500 U	5 U	100 U	50 U	50 U
TRICHLOROETHENE					81	57	184	94	950	49	220	200	130
1 2-DICHLOROPROPANE					5 U	25 U	25 U	50 U	500 U	5 U	100 U	50 U	50 U
BROMODICHLOROMETHANE					5 U	25 U	25 U	50 U	500 U	5 U	100 U	50 U	50 U
CIS-1 3-DICHLOROPROPENE					5 U	25 U	25 U	50 U	500 U	5 U	100 U	50 U	50 U
MIBK					50 U	250 U	250 U	500 U	5000 U	50 U	1000 U	250 U	100 U
TOLUENE					5 U	25 U	25 U	50 U	500 U	5 U	100 U	50 U	50 U
TRANS-1 3-DICHLOROPROPENE					5 U	25 U	25 U	50 U	500 U	5 U	100 U	50 U	50 U
1 1 2-TRICHLOROETHANE					5 U	25 U	25 U	50 U	500 U	5 U	100 U	50 U	50 U
TETRACHLOROETHENE					5 U	25 U	25 U	50 U	500 U	5 U	100 U	50 U	50 U
2-HEXANONE					50 U	250 U	250 U	500 U	5000 U	50 U	1000 U	250 U	100 U
DIBROMOCHLOROMETHANE					5 U	25 U	25 U	50 U	500 U	5 U	100 U	50 U	50 U
CHLOROBENZENE					5 U	25 U	25 U	50 U	500 U	5 U	100 U	50 U	50 U
ETHYLBENZENE					5 U	25 U	25 U	50 U	500 U	5 U	100 U	50 U	50 U
P-XYLENE/M-XYLENE					5 U	25 U	25 U	50 U	500 U	5 U	100 U	50 U	50 U
O-XYLENE					5 U	25 U	25 U	50 U	500 U	5 U	100 U	50 U	50 U
STYRENE					5 U	25 U	25 U	50 U	500 U	5 U	100 U	50 U	50 U
BROMOFORM					5 U	25 U	25 U	50 U	500 U	5 U	100 U	50 U	50 U
1 1 2 2-TETRACHLOROETHANE					5 U	25 U	25 U	50 U	500 U	5 U	100 U	50 U	50 U

NOTES:

U = Below Practical Quantitation Limit (PQL)

Blank = Not sampled

WELL NUMBER 87-08(1)  
 ANALYTICAL SAMPLING RESULTS  
 (Concentrations in ug/L)

ANALYTE	7/17/96	10/16/96	1/15/97	4/30/97	7/23/97	10/30/97	4/98	10/29/98	AVG
CHLOROMETHANE	50 U	120 U	120 U	250 U	25 U	100 U		20 U	0.0
VINYL CHLORIDE	94	120 U	120 U	250 U	53	110		120	98.8
CHLOROETHANE	50 U	120 U	120 U	250 U	25 U	100 U		20 U	0.0
BROMOMETHANE	50 U	120 U	120 U	250 U	25 U	100 U		20 U	0.0
1 1-DICHLOROETHENE	50 U	120 U	120 U	250 U	25 U	100 U		20 U	0.0
ACETONE	250 U	620 U	620 U	1200 U	500 U	500 U		200 U	16.3
CARBON DISULFIDE	50 U	120 U	120 U	250 U	25 U	100 U		20 U	0.0
METHYLENE CHLORIDE	3200	3400	11000	6800	54	870		20 U	1645.9
TRANS-1 2-DICHLOROETHENE	50 U	120 U	120 U	250 U	25 U	100 U		20 U	0.6
1 1-DICHLOROETHANE	50 U	120 U	120 U	250 U	25 U	100 U		20 U	0.0
CIS-1 2-DICHLOROETHENE	1500	1300	1100	1300	1300	1500		1800	1921.7
METHYL ETHYL KETONE	250 U	620 U	620 U	1200 U	500 U	500 U		200 U	0.0
CHLOROFORM	50 U	120 U	120 U	250 U	25 U	100 U		20 U	0.0
1 1 1-TRICHLOROETHANE	50 U	120 U	120 U	250 U	25 U	100 U		20 U	0.0
CARBON TETRACHLORIDE	50 U	120 U	120 U	250 U	25 U	100 U		20 U	0.0
BENZENE	50 U	120 U	120 U	250 U	25 U	100 U		14 U	0.0
1 2-DICHLOROETHANE	50 U	120 U	120 U	250 U	25 U	100 U		20 U	0.0
TRICHLOROETHENE	650	550	550	420	790	400		56	336.3
1 2-DICHLOROPROPANE	50 U	120 U	120 U	250 U	25 U	100 U		20 U	0.0
BROMODICHLOROMETHANE	50 U	120 U	120 U	250 U	25 U	100 U		20 U	0.0
CIS-1 3-DICHLOROPROPENE	50 U	120 U	120 U	250 U	25 U	100 U		20 U	0.0
MIBK	100 U	250 U	250 U	500 U	500 U	200 U		200 U	0.0
TOLUENE	50 U	120 U	120 U	250 U	25 U	100 U		20 U	0.0
TRANS-1 3-DICHLOROPROPENE	50 U	120 U	120 U	250 U	25 U	100 U		20 U	0.0
1 1 2-TRICHLOROETHANE	50 U	120 U	120 U	250 U	25 U	100 U		20 U	0.0
TETRACHLOROETHENE	50 U	120 U	120 U	250 U	25 U	100 U		20 U	0.0
2-HEXANONE	100 U	250 U	250 U	500 U	500 U	200 U		200 U	0.0
DIBROMOCHLOROMETHANE	50 U	120 U	120 U	250 U	25 U	100 U		20 U	0.0
CHLOROBENZENE	50 U	120 U	120 U	250 U	25 U	100 U		20 U	0.0
ETHYLBENZENE	50 U	120 U	120 U	250 U	25 U	100 U		20 U	0.0
P-XYLENE/M-XYLENE	50 U	120 U	120 U	250 U	25 U	100 U		20 U	0.0
O-XYLENE	50 U	120 U	120 U	250 U	25 U	100 U		20 U	0.0
STYRENE	50 U	120 U	120 U	250 U	25 U	100 U		20 U	0.0
BROMOFORM	50 U	120 U	120 U	250 U	25 U	100 U		20 U	0.0
1 1 2 2-TETRACHLOROETHANE	50 U	120 U	120 U	250 U	25 U	100 U		20 U	0.0

NOTES:

U = Below Practical Quantitation Limit (PQL)

Blank = Not sampled

WELL NUMBER 87-10(0)  
ANALYTICAL SAMPLING RESULTS  
(Concentrations in ug/L)

ANALYTE	4/93	7/93	10/93	1/20/94	4/94	7/94	10/94	1/11/95	4/95	7/95	10/95	2/1/96	4/96	7/96	10/16/96
CHLOROMETHANE				0.5 U				0.5 U				0.5 U			0.5 U
VINYL CHLORIDE				0.5 U				0.5 U				0.5 U			0.5 U
CHLOROETHANE				0.5 U				0.5 U				0.8			0.5 U
BROMOMETHANE				0.5 U				0.5 U				0.5 U			0.5 U
1 1-DICHLOROETHENE				0.5 U				0.5				0.5 U			0.5 U
ACETONE				50 U				10 U				10 U			10 U
CARBON DISULFIDE				0.5 U				0.5 U				0.5 U			0.7
METHYLENE CHLORIDE				0.5 U				0.5 U				0.5 U			0.5 U
TRANS-1 2-DICHLOROETHENE				0.6				1				1			0.5 U
1 1-DICHLOROETHANE				2				4				6			2
CIS-1 2-DICHLOROETHENE				85				128				211			54
METHYL ETHYL KETONE				50 U				10 U				10 U			10 U
CHLOROFORM				0.8				2				0.5 U			5
1 1 1-TRICHLOROETHANE				10				15				25			8
CARBON TETRACHLORIDE				0.5 U				0.5 U				4			0.5 U
BENZENE				0.5 U				0.5 U				0.5 U			0.5 U
1 2-DICHLOROETHANE				0.5 U				0.5 U				0.5 U			0.5 U
TRICHLOROETHENE				9				12				5			2
1 2-DICHLOROPROPANE				0.5 U				0.5 U				0.5 U			0.5 U
BROMODICHLOROMETHANE				0.5 U				0.5 U				0.5 U			0.5 U
CIS-1 3-DICHLOROPROPENE				0.5 U				0.5 U				0.5 U			0.5 U
MIBK				50 U				10 U				10 U			10 U
TOLUENE				0.6 U				0.5 U				0.5 U			0.5 U
TRANS-1 3-DICHLOROPROPENE				0.5 U				0.5 U				0.5 U			0.5 U
1 1 2-TRICHLOROETHANE				0.5 U				0.5 U				0.5 U			0.5 U
TETRACHLOROETHENE				0.5 U				0.5 U				0.5 U			0.5 U
2-HEXANONE				50 U				10 U				10 U			10 U
DIBROMOCHLOROMETHANE				0.5 U				0.5 U				0.5 U			0.5 U
CHLOROBENZENE				0.5 U				0.5 U				0.5 U			0.5 U
ETHYLBENZENE				0.5 U				0.5 U				0.5 U			0.5 U
P-XYLENE/M-XYLENE				0.6				0.5 U				0.5 U			0.5 U
O-XYLENE				0.5 U				0.5 U				0.5 U			0.5 U
STYRENE				0.5 U				0.5 U				0.5 U			0.5 U
BROMOFORM				0.5 U				0.5 U				0.5 U			0.5 U
1 1 2 2-TETRACHLOROETHANE				0.5 U				0.5 U				1 U			0.5 U

**NOTES:**

U = Below Practical Quantitation Limit (PQL)

Blank = Not sampled

WELL NUMBER 87-10(0)  
ANALYTICAL SAMPLING RESULTS  
(Concentrations in ug/L)

ANALYTE	1/97	4/97	7/97	10/30/97	4/98	10/29/98	AVG
CHLOROMETHANE				0.5 U		1 U	0.00
VINYL CHLORIDE				0.5 U		1 U	0.00
CHLOROETHANE				0.5 U		1 U	0.13
BROMOMETHANE				0.5 U		1 U	0.00
1 1-DICHLOROETHENE				0.5 U		1 U	0.08
ACETONE				10		10 U	1.67
CARBON DISULFIDE				0.5 U		1 U	0.12
METHYLENE CHLORIDE				0.5 U		1 U	0.00
TRANS-1 2-DICHLOROETHENE				0.5 U		2 J	0.43
1 1-DICHLOROETHANE				1		6	3.50
CIS-1 2-DICHLOROETHENE				46		130	109.00
METHYL ETHYL KETONE				10 U		10 U	0.00
CHLOROFORM				3		2	2.13
1 1 1-TRICHLOROETHANE				3		16	12.83
CARBON TETRACHLORIDE				0.5 U		1 U	0.67
BENZENE				0.5 U		0.700 U	0.00
1 2-DICHLOROETHANE				0.5 U		1 U	0.00
TRICHLOROETHENE				1		6	5.83
1 2-DICHLOROPROPANE				0.5 U		1 U	0.00
BROMODICHLOROMETHANE				0.5 U		1 U	0.00
CIS-1 3-DICHLOROPROPENE				0.5 U		1 U	0.00
MIBK				10 U		10 U	0.00
TOLUENE				0.5 U		1 U	0.00
TRANS-1 3-DICHLOROPROPENE				0.5 U		1 U	0.00
1 1 2-TRICHLOROETHANE				0.5 U		1 U	0.00
TETRACHLOROETHENE				0.5 U		1 U	0.00
2-HEXANONE				10 U		10 U	0.00
DIBROMOCHLOROMETHANE				0.5 U		1 U	0.00
CHLOROBENZENE				0.5 U		1 U	0.00
ETHYLBENZENE				0.5 U		1 U	0.00
P-XYLENE/M-XYLENE				0.5 U		1 U	0.10
O-XYLENE				0.5 U		1 U	0.00
STYRENE				0.5 U		1 U	0.00
BROMOFORM				0.5 U		1 U	0.00
1 1 2 2-TETRACHLOROETHANE				0.5 U		1 U	0.00

**NOTES:**

U = Below Practical Quantitation Limit (PQL)

Blank = Not sampled

WELL NUMBER 87-13(3)  
ANALYTICAL SAMPLING RESULTS  
(Concentrations in ug/L)

ANALYTE	4/93	7/21/93	10/93	1/24/94	4/94	7/21/94	10/25/94	1/12/95	4/20/95	7/12/95	10/19/95	2/2/96	4/17/96
CHLOROMETHANE		5 U		0.5 U	0.5 U	1 U	1 U	0.5 U	5 U	1 U	10 U	3 U	0.5 U
VINYL CHLORIDE		9		24	22	21	25	26	23	32	62	12	10
CHLOROETHANE		5 U		0.5 U	0.5 U	1 U	1 U	0.5 U	5 U	1 U	10 U	3 U	0.5 U
BROMOMETHANE		5 U		0.5 U	0.5 U	1 U	1 U	0.5 U	5 U	1 U	10 U	3 U	0.5 U
1 1-DICHLOROETHENE		5 U		0.6	1	1 U	0.7	1	5 U	1	10 U	3 U	1
ACETONE		50 U		50 U	10 U	10 U	14	10 U	50 U	10	100 U	50 U	10 U
CARBON DISULFIDE		26		23	31	47	41	41	5 U	44	70	40	38
METHYLENE CHLORIDE		5 U		0.5 U	1	1 U	0.7	2	5 U	2	10 U	3	1
TRANS-1 2-DICHLOROETHENE		5 U		0.5 U	1	1 U	0.9	0.8	5 U	1	10 U	3 U	1
1 1-DICHLOROETHANE		5 U		0.5 U	1	1	1	2	5 U	1	10 U	3 U	1
CIS-1 2-DICHLOROETHENE		104		50	153	179	175	224	130	171	390	92	85
METHYL ETHYL KETONE		50 U		50 U	10 U	10 U	10 U	10 U	50 U	10 U	100 U	50 U	10 U
CHLOROFORM		5 U		0.5 U	0.5 U	1 U	1	0.5 U	5 U	1 U	10 U	3 U	0.5 U
1 1 1-TRICHLOROETHANE		5 U		0.5 U	0.5 U	1 U	1 U	1	5 U	1 U	10 U	3 U	0.5 U
CARBON TETRACHLORIDE		5 U		0.5 U	0.5 U	1 U	1 U	0.5 U	5 U	1 U	10 U	3 U	0.5 U
BENZENE		5 U		0.5 U	0.5 U	1 U	1 U	0.5 U	5 U	1 U	10 U	3 U	0.5 U
1 2-DICHLOROETHANE		5 U		0.5 U	0.5 U	1 U	1 U	0.5 U	5 U	1 U	10 U	3 U	0.5 U
TRICHLOROETHENE		134		193	287	282	309	129	192	195	270	228	210
1 2-DICHLOROPROPANE		5 U		0.5 U	0.5 U	1 U	1 U	0.5 U	5 U	1 U	10 U	3 U	0.5 U
BROMODICHLOROMETHANE		5 U		0.5 U	0.5 U	1 U	1 U	0.5 U	5 U	1 U	10 U	3 U	0.5 U
CIS-1 3-DICHLOROPROPENE		5 U		0.5 U	0.5 U	1 U	1 U	0.5 U	5 U	1 U	10 U	3 U	0.5 U
MIBK		50 U		50 U	10 U	10 U	10 U	10 U	50 U	10 U	100 U	50 U	10 U
TOLUENE		5 U		0.6	0.5 U	1 U	1 U	0.5 U	5 U	1 U	10 U	3 U	0.5 U
TRANS-1 3-DICHLOROPROPENE		5 U		0.5 U	0.5 U	1 U	1 U	0.5 U	5 U	1 U	10 U	3 U	0.5 U
1 1 2-TRICHLOROETHANE		5 U		0.5 U	0.5 U	1 U	1 U	0.5 U	5 U	1 U	10 U	3 U	0.5 U
TETRACHLOROETHENE		5 U		0.5 U	0.5 U	1 U	1 U	0.5 U	5 U	1 U	10 U	3 U	0.5 U
2-HEXANONE		50 U		50 U	10 U	10 U	10 U	10 U	50 U	10 U	100 U	50 U	10 U
DIBROMOCHLOROMETHANE		5 U		0.5 U	0.5 U	1 U	1 U	0.5 U	5 U	1 U	10 U	3 U	0.5 U
CHLOROBENZENE		5 U		0.5 U	0.5 U	1 U	1 U	0.5 U	5 U	1 U	10 U	3 U	0.5 U
ETHYLBENZENE		5 U		0.5 U	0.5 U	1 U	1 U	0.5 U	5 U	1 U	10 U	3 U	0.5 U
P-XYLENE/M-XYLENE		5 U		0.5	0.5 U	1 U	1 U	0.5 U	5 U	1 U	10 U	3 U	0.5 U
O-XYLENE		5 U		0.5 U	0.5 U	1 U	1 U	0.5 U	5 U	1 U	10 U	3 U	0.5 U
STYRENE		5 U		0.5 U	0.5 U	1 U	1 U	0.5 U	5 U	1 U	10 U	3 U	0.5 U
BROMOFORM		5 U		0.5 U	0.5 U	1 U	1 U	0.5 U	5 U	1 U	10 U	3 U	0.5 U
1 1 2 2-TETRACHLOROETHANE		5 U		0.5 U	0.5 U	1 U	1 U	0.5 U	5 U	1 U	10 U	5 U	1 U

**NOTES:**

U = Below Practical Quantitation Limit (PQL)

B = Analyte detected in method or trip blank

Blank = Not sampled

WELL NUMBER 87-13(3)  
ANALYTICAL SAMPLING RESULTS  
(Concentrations in ug/L)

ANALYTE	7/17/96	10/18/96	1/15/97	4/30/97	7/23/97	10/31/97	4/23/98	10/30/98	AVG
CHLOROMETHANE	3 U	0.5 U	0.5 U	0.5 U	2 U	5 U	1 U	5 U	0.0
VINYL CHLORIDE	12	9	10	18	10	32	15	19	20.6
CHLOROETHANE	3 U	0.5 U	0.5 U	0.5 U	2 U	5 U	1 U	5 U	0.0
BROMOMETHANE	3 U	0.5 U	0.5 U	0.5 U	2 U	5 U	1 U	5 U	0.0
1 1-DICHLOROETHENE	3 U	0.6	0.5	0.9	2 U	5 U	1 U	5 U	0.4
ACETONE	50 U	0.5 U	10 U	10 U	50 U	25 U	11 B	25 U	1.3
CARBON DISULFIDE	34	124	40	44	42	62	38	35	43.2
METHYLENE CHLORIDE	3 U	1	1	0.8 B	22	5 U	2 U	5 U	1.8
TRANS-1 2-DICHLOROETHENE	3 U	0.6	0.5 U	0.6	2 U	5 U	1 U	5 U	0.3
1 1-DICHLOROETHANE	3 U	0.5 U	0.6	0.7	2 U	5 U	1 U	5 U	0.4
CIS-1 2-DICHLOROETHENE	106	71	80	110	87	140	67	62	130.3
METHYL ETHYL KETONE	50 U	10 U	10 U	10 U	50 U	25 U	10 U	25 U	0.0
CHLOROFORM	3 U	0.5	0.5 U	0.5 U	2 U	5 U	1 U	5 U	0.1
1 1 1-TRICHLOROETHANE	3 U	0.5 U	0.5 U	1 B	2 U	5 U	1 U	5 U	0.1
CARBON TETRACHLORIDE	3 U	0.5 U	0.5 U	0.5 U	2 U	5 U	1 U	5 U	0.0
BENZENE	3 U	0.5 U	0.5 U	0.5 U	2 U	5 U	0.7 U	5 U	0.0
1 2-DICHLOROETHANE	3 U	0.5 U	0.5 U	0.5 U	2 U	5 U	1 U	5 U	0.0
TRICHLOROETHENE	213	190	190	220	170	130	150	92	199.2
1 2-DICHLOROPROPANE	3 U	0.5 U	0.5 U	0.5 U	2 U	5 U	1 U	5 U	0.0
BROMODICHLOROMETHANE	3 U	0.5 U	0.5 U	0.5 U	2 U	5 U	1 U	5 U	0.0
CIS-1 3-DICHLOROPROPENE	3 U	0.5 U	0.5 U	0.5 U	2 U	5 U	1 U	5 U	0.0
MIBK	50 U	10 U	10 U	10 U	50 U	10 U	10 U	10 U	0.0
TOLUENE	3 U	0.5 U	0.5 U	0.5 U	2 U	5 U	1 U	5 U	0.0
TRANS-1 3-DICHLOROPROPENE	3 U	0.5 U	0.5 U	0.5 U	2 U	5 U	1 U	5 U	0.0
1 1 2-TRICHLOROETHANE	3 U	0.5 U	0.5 U	0.5 U	2 U	5 U	1 U	5 U	0.0
TETRACHLOROETHENE	3 U	0.5 U	0.5 U	0.5 U	2 U	5 U	1 U	5 U	0.0
2-HEXANONE	50 U	10 U	10 U	10 U	50 U	10 U	10 U	10 U	0.0
DIBROMOCHLOROMETHANE	3 U	0.5 U	0.5 U	0.5 U	2 U	5 U	1 U	5 U	0.0
CHLOROBENZENE	3 U	0.5 U	0.5 U	0.5 U	2 U	5 U	1 U	5 U	0.0
ETHYLBENZENE	3 U	0.5 U	0.5 U	0.5 U	2 U	5 U	1 U	5 U	0.0
P-XYLENE/M-XYLENE	3 U	0.5 U	0.5 U	0.5 U	2 U	5 U	1 U	5 U	0.0
O-XYLENE	3 U	0.5 U	0.5 U	0.5 U	2 U	5 U	1 U	5 U	0.0
STYRENE	3 U	0.5 U	0.5 U	0.5 U	2 U	5 U	1 U	5 U	0.0
BROMOFORM	3 U	0.5 U	0.5 U	0.5 U	2 U	5 U	1 U	5 U	0.0
1 1 2 2-TETRACHLOROETHANE	5 U	0.5 U	0.5 U	0.5 U	2 U	5 U	1 U	5 U	0.0

NOTES:

U = Below Practical Quantitation Limit (PQL)

B = Analyte detected in method or trip blank

Blank = Not sampled

WELL NUMBER 87-14(0)  
ANALYTICAL SAMPLING RESULTS  
(Concentrations in ug/L)

ANALYTE	4/93	7/93	10/93	1/94	4/94	7/94	10/94	1/12/95	4/95	7/95	10/95	2/2/96	4/96	7/96	10/18/96
CHLOROMETHANE								0.5 U				0.5 U			0.5 U
VINYL CHLORIDE								7				6			4
CHLOROETHANE								0.5 U				0.5 U			0.5 U
BROMOMETHANE								0.5 U				0.5 U			0.5 U
1 1-DICHLOROETHENE								95				44			36
ACETONE								10 U				10 U			10 U
CARBON DISULFIDE								2				0.5 U			96
METHYLENE CHLORIDE								14				820			0.5 U
TRANS-1 2-DICHLOROETHENE								210				45			64
1 1-DICHLOROETHANE								4				2			2
CIS-1 2-DICHLOROETHENE								0.5 U				9200			7150
METHYL ETHYL KETONE								10 U				10 U			10 U
CHLOROFORM								0.5 U				163			160
1 1 1-TRICHLOROETHANE								2				0.5 U			1
CARBON TETRACHLORIDE								0.5 U				0.5 U			2
BENZENE								30				15			12
1 2-DICHLOROETHANE								0.5 U				0.5 U			0.5 U
TRICHLOROETHENE								0.5 U				18000			13200
1 2-DICHLOROPROPANE								0.5 U				0.5 U			0.5 U
BROMODICHLOROMETHANE								0.5 U				0.5 U			0.5 U
CIS-1 3-DICHLOROPROPENE								0.5 U				0.5 U			0.5 U
MIBK								10 U				10 U			10 U
TOLUENE								7				3			2
TRANS-1 3-DICHLOROPROPENE								0.5 U				0.5 U			0.5 U
1 1 2-TRICHLOROETHANE								3				2			2
TETRACHLOROETHENE								0.5 U				0.5 U			0.5 U
2-HEXANONE								10 U				10 U			10 U
DIBROMOCHLOROMETHANE								0.5 U				0.5 U			0.5 U
CHLOROBENZENE								0.5 U				0.5 U			0.5 U
ETHYLBENZENE								0.5 U				0.8			0.6
P-XYLENE/M-XYLENE								0.5 U				2			1
O-XYLENE								0.5 U				0.8			0.9
STYRENE								0.5 U				0.5 U			0.5 U
BROMOFORM								0.5 U				0.5 U			0.5 U
1 1 2 2-TETRACHLOROETHANE								0.5 U				1 U			0.5 U

**NOTES:**

U = Below Practical Quantitation Limit (PQL)

Blank = Not sampled

WELL NUMBER 87-14(0)  
ANALYTICAL SAMPLING RESULTS  
(Concentrations in ug/L)

ANALYTE	1/97	4/97	7/97	10/31/97	4/98	10/29/98	AVG
CHLOROMETHANE				0.5 U		2500 U	0.0
VINYL CHLORIDE				2		2500 U	3.8
CHLOROETHANE				0.5 U		2500 U	0.0
BROMOMETHANE				0.5 U		2500 U	0.0
1 1-DICHLOROETHENE				23		2500 U	39.6
ACETONE				10 U		13000 U	0.0
CARBON DISULFIDE				2		2500 U	20.0
METHYLENE CHLORIDE				0.5 U		2500 U	166.8
TRANS-1 2-DICHLOROETHENE				29		2500 U	69.6
1 1-DICHLOROETHANE				1		2500 U	1.8
CIS-1 2-DICHLOROETHENE				3800		4800	4990.0
METHYL ETHYL KETONE				10 U		13000 U	0.0
CHLOROFORM				85		2500 U	81.6
1 1 1-TRICHLOROETHANE				0.5 U		2500 U	0.6
CARBON TETRACHLORIDE				0.5 U		2500 U	0.4
BENZENE				6		2500 U	12.6
1 2-DICHLOROETHANE				0.5 U		2500 U	0.0
TRICHLOROETHENE				9500		17000	11540.0
1 2-DICHLOROPROPANE				0.5 U		2500 U	0.0
BROMODICHLOROMETHANE				0.5 U		2500 U	0.0
CIS-1 3-DICHLOROPROPENE				0.5 U		2500 U	0.0
MIBK				10 U		5000 U	0.0
TOLUENE				1		2500 U	2.6
TRANS-1 3-DICHLOROPROPENE				0.5 U		2500 U	0.0
1 1 2-TRICHLOROETHANE				2		2500 U	1.8
TETRACHLOROETHENE				0.5 U		2500 U	0.0
2-HEXANONE				10 U		5000 U	0.0
DIBROMOCHLOROMETHANE				0.5 U		2500 U	0.0
CHLOROBENZENE				0.5 U		2500 U	0.0
ETHYLBENZENE				0.5 U		2500 U	0.3
P-XYLENE/M-XYLENE				0.7		2500 U	0.7
O-XYLENE				0.7		2500 U	0.5
STYRENE				0.5 U		2500 U	0.0
BROMOFORM				0.5 U		2500 U	0.0
1 1 2-TETRACHLOROETHANE				0.5 U		2500 U	0.0

## NOTES:

U = Below Practical Quantitation Limit (PQL)

Blank = Not sampled



WELL NUMBER 87-17(1)  
 ANALYTICAL SAMPLING RESULTS  
 (Concentrations in ug/L)

ANALYTE	4/93	7/93	10/93	1/94	4/28/94	7/21/94	10/25/94	1/12/95	4/20/95	7/12/95	10/19/95	2/1/96	4/17/96
CHLOROMETHANE					5 U	50 U	50 U	25 U	25 U	50 U	25 U	50 U	25 U
VINYL CHLORIDE					101	96	69	103	82	95	125	130	120
CHLOROETHANE					5 U	50 U	50 U	25 U	25 U	50 U	25 U	50 U	25 U
BROMOMETHANE					5 U	50 U	50 U	25 U	25 U	50 U	25 U	50 U	25 U
1 1-DICHLOROETHENE					5 U	50 U	50 U	25 U	25 U	50 U	25 U	50 U	25 U
ACETONE					50 U	500 U	500 U	250 U	250 U	500 U	250 U	250 U	125 U
CARBON DISULFIDE					5 U	50 U	50 U	25 U	25 U	50 U	25 U	50 U	25 U
METHYLENE CHLORIDE					5 U	50 U	50 U	25 U	25 U	50 U	25 U	50 U	25 U
TRANS-1 2-DICHLOROETHENE					6	50 U	50 U	25 U	25 U	50 U	25 U	50 U	25 U
1 1-DICHLOROETHANE					29	50 U	50 U	25 U	25 U	50 U	25 U	50 U	25 U
CIS-1 2-DICHLOROETHENE					814	747	310	757	655	660	830	610	570
METHYL ETHYL KETONE					50 U	500 U	500 U	250 U	250 U	500 U	250 U	250 U	125 U
CHLOROFORM					5 U	50 U	50 U	25 U	25 U	50 U	25 U	50 U	25 U
1 1 1-TRICHLOROETHANE					196	50 U	50 U	147	142	131	120	80	89
CARBON TETRACHLORIDE					5 U	50 U	50 U	25 U	25 U	50 U	25 U	50 U	25 U
BENZENE					5 U	50 U	50 U	25 U	25 U	50 U	25 U	50 U	25 U
1 2-DICHLOROETHANE					5 U	50 U	50 U	25 U	25 U	50 U	25 U	50 U	25 U
TRICHLOROETHENE					60	104	50 U	55	25 U	50 U	25 U	50 U	25 U
1 2-DICHLOROPROPANE					5 U	50 U	50 U	25 U	25 U	50 U	25 U	50 U	25 U
BROMODICHLOROMETHANE					5 U	50 U	50 U	25 U	25 U	50 U	25 U	50 U	25 U
CIS-1 3-DICHLOROPROPENE					5 U	50 U	50 U	25 U	25 U	50 U	25 U	50 U	25 U
MIBK					50 U	500 U	500 U	250 U	250 U	500 U	250 U	250 U	50 U
TOLUENE					5 U	50 U	50 U	25 U	25 U	50 U	25 U	50 U	25 U
TRANS-1 3-DICHLOROPROPENE					5 U	50 U	50 U	25 U	25 U	50 U	25 U	50 U	25 U
1 1 2-TRICHLOROETHANE					5 U	50 U	50 U	25 U	25 U	50 U	25 U	50 U	25 U
TETRACHLOROETHENE					5 U	50 U	50 U	25 U	25 U	50 U	25 U	50 U	25 U
2-HEXANONE					50 U	500 U	500 U	250 U	250 U	500 U	250 U	250 U	50 U
DIBROMOCHLOROMETHANE					5 U	50 U	50 U	25 U	25 U	50 U	25 U	50 U	25 U
CHLOROBENZENE					5 U	50 U	50 U	25 U	25 U	50 U	25 U	50 U	25 U
ETHYLBENZENE					5 U	50 U	50 U	25 U	25 U	50 U	25 U	50 U	25 U
P-XYLENE/M-XYLENE					5 U	50 U	50 U	25 U	25 U	50 U	25 U	50 U	25 U
O-XYLENE					5 U	50 U	50 U	25 U	25 U	50 U	25 U	50 U	25 U
STYRENE					5 U	50 U	50 U	25 U	25 U	50 U	25 U	50 U	25 U
BROMOFORM					5 U	50 U	50 U	25 U	25 U	50 U	25 U	50 U	25 U
1 1 2 2-TETRACHLOROETHANE					5 U	50 U	50 U	25 U	25 U	50 U	25 U	50 U	25 U

NOTES:

U = Below Practical Quantitation Limit (PQL)

Blank = Not sampled

WELL NUMBER 87-17(1)  
ANALYTICAL SAMPLING RESULTS  
(Concentrations in ug/L)

ANALYTE	7/17/96	10/16/96	1/15/97	4/30/97	7/23/97	10/31/97	4/98	10/30/98	AVG
CHLOROMETHANE	25 U	25 U	25 U	2.5 U	2 U	25 U		5 U	0.0
VINYL CHLORIDE	91	59	100	100	89	120		91	98.2
CHLOROETHANE	25 U	25 U	25 U	2.5 U	2 U	25 U		5 U	0.0
BROMOMETHANE	25 U	25 U	25 U	2.5 U	2 U	25 U		5 U	0.0
1 1-DICHLOROETHENE	25 U	25 U	25 U	4	2 U	25 U		3 J	0.3
ACETONE	125 U	120 U	120 U	50 U	50 U	120 U		25 U	0.0
CARBON DISULFIDE	25 U	25 U	25 U	2.5 U	2 U	25 U		5 U	0.0
METHYLENE CHLORIDE	25 U	25 U	25 U	2.5 U	3	25 U		61	4.0
TRANS-1 2-DICHLOROETHENE	25 U	25 U	25 U	4	3	25 U		2 J	0.8
1 1-DICHLOROETHANE	25 U	25 U	25 U	23	24	38		17	8.2
CIS-1 2-DICHLOROETHENE	670	450	590	590	530	680		540	625.2
METHYL ETHYL KETONE	125 U	120 U	120 U	50 U	50 U	120 U		25 U	0.0
CHLOROFORM	25 U	25 U	25 U	2.5 U	5	25 U		5 U	0.3
1 1 1-TRICHLOROETHANE	100	61	81	120	100	140		74	98.8
CARBON TETRACHLORIDE	25 U	25 U	25 U	2.5 U	2 U	25 U		5 U	0.0
BENZENE	25 U	25 U	25 U	2.5 U	2 U	25 U		5 U	0.0
1 2-DICHLOROETHANE	25 U	25 U	25 U	2.5 U	2 U	25 U		5 U	0.0
TRICHLOROETHENE	25 U	25 U	25 U	24	13	25 U		28	17.8
1 2-DICHLOROPROPANE	25 U	25 U	25 U	2.5 U	2 U	25 U		5 U	0.0
BROMODICHLOROMETHANE	25 U	25 U	25 U	2.5 U	2 U	25 U		5 U	0.0
CIS-1 3-DICHLOROPROPENE	25 U	25 U	25 U	2.5 U	2 U	25 U		5 U	0.0
MIBK	50 U	50 U	50 U	50 U	50 U	50 U		10 U	0.0
TOLUENE	25 U	25 U	25 U	2.5 U	2 U	25 U		5 U	0.0
TRANS-1 3-DICHLOROPROPENE	25 U	25 U	25 U	2.5 U	2 U	25 U		5 U	0.0
1 1 2-TRICHLOROETHANE	25 U	25 U	25 U	2.5 U	2 U	25 U		5 U	0.0
TETRACHLOROETHENE	25 U	25 U	25 U	2.5 U	2 U	25 U		5 U	0.0
2-HEXANONE	50 U	50 U	50 U	50 U	50 U	50 U		10 U	0.0
DIBROMOCHLOROMETHANE	25 U	25 U	25 U	2.5 U	2 U	25 U		5 U	0.0
CHLOROBENZENE	25 U	25 U	25 U	2.5 U	2 U	25 U		5 U	0.0
ETHYLBENZENE	25 U	25 U	25 U	2.5 U	2 U	25 U		5 U	0.0
P-XYLENE/M-XYLENE	25 U	25 U	25 U	2.5 U	2 U	25 U		5 U	0.0
O-XYLENE	25 U	25 U	25 U	2.5 U	2 U	25 U		5 U	0.0
STYRENE	25 U	25 U	25 U	2.5 U	2 U	25 U		5 U	0.0
BROMOFORM	25 U	25 U	25 U	2.5 U	2 U	25 U		5 U	0.0
1 1 2 2-TETRACHLOROETHANE	25 U	25 U	25 U	2.5 U	2 U	25 U		5 U	0.0

## NOTES:

U = Below Practical Quantitation Limit (PQL)

Blank = Not sampled

WELL NUMBER 87-18(0)  
ANALYTICAL SAMPLING RESULTS  
(Concentrations in ug/L)

ANALYTE	4/93	7/93	10/93	1/94	4/94	7/94	10/94	1/95	4/95	7/95	10/95	1/31/96	4/18/96	7/96	10/96	1/97
CHLOROMETHANE												0.5 U	0.5 U			
VINYL CHLORIDE												0.5 U	0.5 U			
CHLOROETHANE												0.5 U	0.5 U			
BROMOMETHANE												0.5 U	0.5 U			
1 1-DICHLOROETHENE												0.5 U	0.5 U			
ACETONE												10 U	10 U			
CARBON DISULFIDE												0.5 U	0.5 U			
METHYLENE CHLORIDE												0.5 U	0.5 U			
TRANS-1 2-DICHLOROETHENE												0.5 U	0.5 U			
1 1-DICHLOROETHANE												0.5 U	0.5 U			
CIS-1 2-DICHLOROETHENE												0.5 U	0.5 U			
METHYL ETHYL KETONE												10 U	10 U			
CHLOROFORM												0.5 U	0.5 U			
1 1 1-TRICHLOROETHANE												0.5 U	0.5 U			
CARBON TETRACHLORIDE												0.5 U	0.5 U			
BENZENE												0.5 U	0.5 U			
1 2-DICHLOROETHANE												0.5 U	0.5 U			
TRICHLOROETHENE												0.5 U	0.5 U			
1 2-DICHLOROPROPANE												0.5 U	0.5 U			
BROMODICHLOROMETHANE												0.5 U	0.5 U			
CIS-1 3-DICHLOROPROPENE												0.5 U	0.5 U			
MIBK												10 U	10 U			
TOLUENE												0.5 U	0.5 U			
TRANS-1 3-DICHLOROPROPENE												0.5 U	0.5 U			
1 1 2-TRICHLOROETHANE												0.5 U	0.5 U			
TETRACHLOROETHENE												0.5 U	0.5 U			
2-HEXANONE												10 U	10 U			
DIBROMOCHLOROMETHANE												0.5 U	0.5 U			
CHLOROBENZENE												0.5 U	0.5 U			
ETHYLBENZENE												0.5 U	0.5 U			
P-XYLENE/M-XYLENE												0.5 U	0.5 U			
O-XYLENE												0.5 U	0.5 U			
STYRENE												0.5 U	0.5 U			
BROMOFORM												0.5 U	0.5 U			
1 1 2-TETRACHLOROETHANE												1 U	1 U			

NOTES:

Blank = Not sampled

WELL NUMBER 87-18(0)  
ANALYTICAL SAMPLING RESULTS  
(Concentrations in ug/L)

ANALYTE	4/29/97	7/97	10/31/97	4/98	10/29/98	AVG
CHLOROMETHANE	0.5 U		0.5 U		1 U	0.0
VINYL CHLORIDE	0.5 U		0.5 U		1 U	0.0
CHLOROETHANE	0.5 U		0.5 U		1 U	0.0
BROMOMETHANE	0.5 U		0.5 U		1 U	0.0
1 1-DICHLOROETHENE	0.5 U		0.5 U		1 U	0.0
ACETONE	10 U		10 U		10 U	0.0
CARBON DISULFIDE	0.5 U		0.5 U		1 U	0.0
METHYLENE CHLORIDE	0.5 U		0.5 U		1 U	0.0
TRANS-1 2-DICHLOROETHENE	0.5 U		0.5 U		1 U	0.0
1 1-DICHLOROETHANE	0.5 U		0.5 U		1 U	0.0
CIS-1 2-DICHLOROETHENE	0.5 U		0.5 U		1 U	0.0
METHYL ETHYL KETONE	10 U		10 U		10 U	0.0
CHLOROFORM	0.5 U		0.5 U		1 U	0.0
1 1 1-TRICHLOROETHANE	0.5 U		0.5 U		1 U	0.0
CARBON TETRACHLORIDE	0.5 U		0.5 U		1 U	0.0
BENZENE	0.5 U		0.5 U		0.700 U	0.0
1 2-DICHLOROETHANE	0.5 U		0.5 U		1 U	0.0
TRICHLOROETHENE	0.5 U		0.5 U		1 U	0.0
1 2-DICHLOROPROPANE	0.5 U		0.5 U		1 U	0.0
BROMODICHLOROMETHANE	0.5 U		0.5 U		1 U	0.0
CIS-1 3-DICHLOROPROPENE	0.5 U		0.5 U		1 U	0.0
MIBK	10 U		10 U		10 U	0.0
TOLUENE	0.5 U		0.5 U		1 U	0.0
TRANS-1 3-DICHLOROPROPENE	0.5 U		0.5 U		1 U	0.0
1 1 2-TRICHLOROETHANE	0.5 U		0.5 U		1 U	0.0
TETRACHLOROETHENE	0.5 U		0.5 U		1 U	0.0
2-HEXANONE	10 U		10 U		10 U	0.0
DIBROMOCHLOROMETHANE	0.5 U		0.5 U		1 U	0.0
CHLOROBENZENE	0.5 U		0.5 U		1 U	0.0
ETHYLBENZENE	0.5 U		0.5 U		1 U	0.0
P-XYLENE/M-XYLENE	0.5 U		0.5 U		1 U	0.0
O-XYLENE	0.5 U		0.5 U		1 U	0.0
STYRENE	0.5 U		0.5 U		1 U	0.0
BROMOFORM	0.5 U		0.5 U		1 U	0.0
1 1 2 2-TETRACHLOROETHANE	0.5 U		0.5 U		1 U	0.0

**NOTES:**

Blank = Not sampled

WELL NUMBER 87-19(1)  
ANALYTICAL SAMPLING RESULTS  
(Concentrations in ug/L)

ANALYTE	4/93	7/93	10/93	1/20/94	4/94	7/20/94	10/94	1/9/95	4/95	7/11/95	10/95	1/30/96	4/18/96	7/96
CHLOROMETHANE				0.5 U		5 U		0.5 U		5 U		0.5 U	0.5 U	
VINYL CHLORIDE				0.5 U		5 U		0.5 U		5 U		0.5 U	0.5 U	
CHLOROETHANE				0.5 U		5 U		0.5 U		5 U		0.5 U	0.5 U	
BROMOMETHANE				0.5 U		5 U		0.5 U		5 U		0.5 U	0.5 U	
1 1-DICHLOROETHENE				0.5 U		5 U		0.5 U		5 U		0.5 U	0.5 U	
ACETONE				50 U		50 U		10 U		50 U		10 U	10 U	
CARBON DISULFIDE				0.5 U		5 U		0.5 U		5 U		0.5 U	0.5 U	
METHYLENE CHLORIDE				0.5 U		5 U		0.5 U		5 U		0.5 U	0.5 U	
TRANS-1 2-DICHLOROETHENE				0.5 U		5 U		0.5 U		5 U		0.5 U	0.5 U	
1 1-DICHLOROETHANE				0.5 U		5 U		0.5 U		5 U		0.5 U	0.5 U	
CIS-1 2-DICHLOROETHENE				2		5 U		0.9		5 U		4	5	
METHYL ETHYL KETONE				50 U		50 U		10 U		50 U		10 U	10 U	
CHLOROFORM				0.5 U		5 U		0.5 U		5 U		0.5 U	0.5 U	
1 1 1-TRICHLOROETHANE				0.5 U		5 U		0.5 U		5 U		0.5 U	0.5 U	
CARBON TETRACHLORIDE				0.5 U		5 U		0.5 U		5 U		0.5 U	0.5 U	
BENZENE				0.5 U		5 U		0.5 U		5 U		0.5 U	0.5 U	
1 2-DICHLOROETHANE				0.5 U		5 U		0.5 U		5 U		0.5 U	0.5 U	
TRICHLOROETHENE				1		5 U		0.5 U		5 U		2	2	
1 2-DICHLOROPROPANE				0.5 U		5 U		0.5 U		5 U		0.5 U	0.5 U	
BROMODICHLOROMETHANE				0.5 U		5 U		0.5 U		5 U		0.5 U	0.5 U	
CIS-1 3-DICHLOROPROPENE				0.5 U		5 U		0.5 U		5 U		0.5 U	0.5 U	
MIBK				50 U		50 U		10 U		50 U		10 U	10 U	
TOLUENE				0.5 U		5 U		0.5 U		5 U		0.5 U	0.5 U	
TRANS-1 3-DICHLOROPROPENE				0.5 U		5 U		0.5 U		5 U		0.5 U	0.5 U	
1 1 2-TRICHLOROETHANE				0.5 U		5 U		0.5 U		5 U		0.5 U	0.5 U	
TETRACHLOROETHENE				0.5 U		5 U		0.5 U		5 U		0.5 U	0.5 U	
2-HEXANONE				50 U		50 U		10 U		50 U		10 U	10 U	
DIBROMOCHLOROMETHANE				0.5 U		5 U		0.5 U		5 U		0.5 U	0.5 U	
CHLOROBENZENE				0.5 U		5 U		0.5 U		5 U		0.5 U	0.5 U	
ETHYLBENZENE				0.5 U		5 U		0.5 U		5 U		0.5 U	0.5 U	
P-XYLENE/M-XYLENE				0.5 U		5 U		0.5 U		5 U		0.5 U	0.5 U	
O-XYLENE				0.5 U		5 U		0.5 U		5 U		0.5 U	0.5 U	
STYRENE				0.5 U		5 U		0.5 U		5 U		0.5 U	0.5 U	
BROMOFORM				0.5 U		5 U		0.5 U		5 U		0.5 U	0.5 U	
1 1 2-TETRACHLOROETHANE				0.5 U		5 U		0.5 U		5 U		1 U	1 U	

**NOTES:**

U = Below Practical Quantitation Limit (PQL)

Blank = Not sampled

WELL NUMBER 87-19(1)  
ANALYTICAL SAMPLING RESULTS  
(Concentrations in ug/L)

ANALYTE	10/15/96	1/97	4/29/97	7/97	10/28/97	4/22/98	10/27/98	AVG
CHLOROMETHANE	0.5 U		0.5 U		0.5 U	1 U	1 U	0.0
VINYL CHLORIDE	0.5 U		0.6		3	1 U	1 U	0.3
CHLOROETHANE	0.5 U		0.5 U		0.5 U	1 U	1 U	0.0
BROMOMETHANE	0.5 U		0.5 U		0.5 U	1 U	1 U	0.0
1 1-DICHLOROETHENE	0.5 U		0.5 U		0.5 U	1 U	1 U	0.0
ACETONE	10 U		10 U		10 U	10 U	10 U	0.0
CARBON DISULFIDE	0.5 U		0.5 U		0.5 U	2	1 U	0.2
METHYLENE CHLORIDE	0.5 U		0.5 U		0.5 U	2 U	1 U	0.0
TRANS-1 2-DICHLOROETHENE	0.5 U		0.5 U		0.5 U	1 U	1 U	0.0
1 1-DICHLOROETHANE	0.5 U		0.5 U		0.5 U	1 U	1 U	0.0
CIS-1 2-DICHLOROETHENE	7		6		9	7	8	4.4
METHYL ETHYL KETONE	10 U		10 U		10 U	10 U	10 U	0.0
CHLOROFORM	0.5 U		0.5 U		0.5 U	1 U	1 U	0.0
1 1 1-TRICHLOROETHANE	0.5 U		0.5 U		0.5 U	1 U	1 U	0.0
CARBON TETRACHLORIDE	0.5 U		0.5 U		0.5 U	1 U	1 U	0.0
BENZENE	0.5 U		0.5 U		0.5 U	0.7 U	0.700 U	0.0
1 2-DICHLOROETHANE	0.5 U		0.5 U		0.5 U	1 U	1 U	0.0
TRICHLOROETHENE	3		2		3	3	4	1.8
1 2-DICHLOROPROPANE	0.5 U		0.5 U		0.5 U	1 U	1 U	0.0
BROMODICHLOROMETHANE	0.5 U		0.5 U		0.5 U	1 U	1 U	0.0
CIS-1 3-DICHLOROPROPENE	0.5 U		0.5 U		0.5 U	1 U	1 U	0.0
MIBK	10 U		10 U		10 U	10 U	10 U	0.0
TOLUENE	0.5 U		0.5 U		0.5 U	1 U	1 U	0.0
TRANS-1 3-DICHLOROPROPENE	0.5 U		0.5 U		0.5 U	1 U	1 U	0.0
1 1 2-TRICHLOROETHANE	0.5 U		0.5 U		0.5 U	1 U	1 U	0.0
TETRACHLOROETHENE	0.5 U		0.5 U		0.5 U	1 U	1 U	0.0
2-HEXANONE	10 U		10 U		10 U	10 U	10 U	0.0
DIBROMOCHLOROMETHANE	0.5 U		0.5 U		0.5 U	1 U	1 U	0.0
CHLOROBENZENE	0.5 U		0.5 U		0.5 U	1 U	1 U	0.0
ETHYLBENZENE	0.5 U		0.5 U		0.5 U	1 U	1 U	0.0
P-XYLENE/M-XYLENE	0.5 U		0.5 U		0.5 U	1 U	1 U	0.0
O-XYLENE	0.5 U		0.5 U		0.5 U	1 U	1 U	0.0
STYRENE	0.5 U		0.5 U		0.5 U	1 U	1 U	0.0
BROMOFORM	0.5 U		0.5 U		0.5 U	1 U	1 U	0.0
1 1 2 2-TETRACHLOROETHANE	0.5 U		0.5 U		0.5 U	1 U	1 U	0.0

**NOTES:**

U = Below Practical Quantitation Limit (PQL)

Blank = Not sampled

WELL NUMBER 87-20(0)  
ANALYTICAL SAMPLING RESULTS  
(Concentrations in ug/L)

ANALYTE	4/93	7/20/93	10/93	1/21/94	4/94	7/20/94	10/94	1/9/95	4/95	7/95	10/95	1/30/96	4/18/96	7/96
CHLOROMETHANE		0.5 U		0.5 U		1 U		0.5 U				0.5 U	0.5 U	
VINYL CHLORIDE		0.5 U		0.5 U		1 U		0.5 U				0.5 U	0.5 U	
CHLOROETHANE		0.5 U		0.5 U		1 U		0.5 U				0.5 U	0.5 U	
BROMOMETHANE		0.5 U		0.5 U		1 U		0.5 U				0.5 U	0.5 U	
1 1-DICHLOROETHENE		0.5 U		0.5 U		1 U		0.5 U				0.5 U	0.5 U	
ACETONE		20 U		50 U		10 U		10 U				10 U	10 U	
CARBON DISULFIDE		0.5 U		0.5 U		1 U		1				0.5 U	0.5 U	
METHYLENE CHLORIDE		0.5 U		0.5 U		1 U		0.5 U				0.5 U	0.5 U	
TRANS-1 2-DICHLOROETHENE		0.5 U		0.5 U		1 U		0.5 U				0.5 U	0.5 U	
1 1-DICHLOROETHANE		0.5 U		0.5 U		1 U		3				0.5 U	0.5 U	
CIS-1 2-DICHLOROETHENE		0.5 U		0.5 U		1 U		0.5 U				0.5 U	0.5 U	
METHYL ETHYL KETONE		20 U		50 U		10 U		10 U				10 U	10 U	
CHLOROFORM		0.5 U		0.5 U		1 U		0.5 U				0.5 U	0.5 U	
1 1 1-TRICHLOROETHANE		0.5 U		0.5 U		1 U		0.5 U				0.5 U	0.5 U	
CARBON TETRACHLORIDE		0.5 U		0.5 U		1 U		0.5 U				0.5 U	0.5 U	
BENZENE		0.5 U		0.5 U		1 U		0.5 U				0.5 U	0.5 U	
1 2-DICHLOROETHANE		0.5 U		0.5 U		1 U		0.5 U				0.5 U	0.5 U	
TRICHLOROETHENE		0.5 U		0.5 U		1 U		0.5 U				0.5 U	0.5 U	
1 2-DICHLOROPROPANE		0.5 U		0.5 U		1 U		0.5 U				0.5 U	0.5 U	
BROMODICHLOROMETHANE		0.5 U		0.5 U		1 U		0.5 U				0.5 U	0.5 U	
CIS-1 3-DICHLOROPROPENE		0.5 U		0.5 U		1 U		0.5 U				0.5 U	0.5 U	
MIBK		20 U		50 U		10 U		10 U				10 U	10 U	
TOLUENE		0.5 U		0.5 U		1 U		0.5 U				0.5 U	0.5 U	
TRANS-1 3-DICHLOROPROPENE		0.5 U		0.5 U		1 U		0.5 U				0.5 U	0.5 U	
1 1 2-TRICHLOROETHANE		0.5 U		0.5 U		1 U		0.5 U				0.5 U	0.5 U	
TETRACHLOROETHENE		0.5 U		0.5 U		1 U		0.5 U				0.5 U	0.5 U	
2-HEXANONE		20 U		50 U		10 U		10 U				10 U	10 U	
DIBROMOCHLOROMETHANE		0.5 U		0.5 U		1 U		0.5 U				0.5 U	0.5 U	
CHLOROBENZENE		0.5 U		0.5 U		1 U		0.5 U				0.5 U	0.5 U	
ETHYLBENZENE		0.5 U		0.5 U		1 U		0.5 U				0.5 U	0.5 U	
P-XYLENE/M-XYLENE		0.5 U		0.5 U		1 U		0.5 U				0.5 U	0.5 U	
O-XYLENE		0.5 U		0.5 U		1 U		0.5 U				0.5 U	0.5 U	
STYRENE		0.5 U		0.5 U		1 U		0.5 U				0.5 U	0.5 U	
BROMOFORM		0.5 U		0.5 U		1 U		0.5 U				0.5 U	0.5 U	
1 1 2 2-TETRACHLOROETHANE		0.5 U		0.5 U		1 U		0.5 U				1 U	1 U	

## NOTES:

U = Below Practical Quantitation Limit (PQL)

Blank = Not sampled

WELL NUMBER 87-20(0)  
ANALYTICAL SAMPLING RESULTS  
(Concentrations in ug/L)

ANALYTE	10/17/96	1/97	4/97	7/22/97	10/29/97	4/20/98	10/28/98	AVG
CHLOROMETHANE	0.5 U			0.5 U	0.5 U	1 U	1 U	0.0
VINYL CHLORIDE	0.5 U			0.5 U	0.5 U	1 U	1 U	0.0
CHLOROETHANE	0.5 U			0.5 U	0.5 U	1 U	1 U	0.0
BROMOMETHANE	0.5 U			0.5 U	0.5 U	1 U	1 U	0.0
1 1-DICHLOROETHENE	0.5 U			0.5 U	0.5 U	1 U	1 U	0.0
ACETONE	10 U			10 U	10 U	10 U	10 U	0.0
CARBON DISULFIDE	0.5 U			0.5 U	0.5 U	1 U	1 U	0.1
METHYLENE CHLORIDE	0.5 U			0.5 U	0.5 U	2 U	1 U	0.0
TRANS-1 2-DICHLOROETHENE	0.5 U			0.5 U	0.5 U	1 U	1 U	0.0
1 1-DICHLOROETHANE	0.5 U			0.5 U	0.5 U	1 U	1 U	0.3
CIS-1 2-DICHLOROETHENE	0.5 U			0.5 U	0.5 U	1 U	1 U	0.0
METHYL ETHYL KETONE	10 U			10 U	10 U	10 U	10 U	0.0
CHLOROFORM	0.5 U			0.5 U	0.5 U	1 U	1 U	0.0
1 1 1-TRICHLOROETHANE	0.5 U			0.5 U	0.5 U	1 U	1 U	0.0
CARBON TETRACHLORIDE	0.5 U			0.5 U	0.5 U	1 U	1 U	0.0
BENZENE	0.5 U			0.5 U	0.5 U	0.7 U	0.700 U	0.0
1 2-DICHLOROETHANE	0.5 U			0.5 U	0.5 U	1 U	1 U	0.0
TRICHLOROETHENE	0.6			0.5 U	0.5 U	1 U	1 U	0.1
1 2-DICHLOROPROPANE	0.5 U			0.5 U	0.5 U	1 U	1 U	0.0
BROMODICHLOROMETHANE	0.5 U			0.5 U	0.5 U	1 U	1 U	0.0
CIS-1 3-DICHLOROPROPENE	0.5 U			0.5 U	0.5 U	1 U	1 U	0.0
MIBK	10 U			10 U	10 U	10 U	10 U	0.0
TOLUENE	0.5 U			0.5 U	0.5 U	1 U	1 U	0.0
TRANS-1 3-DICHLOROPROPENE	0.5 U			0.5 U	0.5 U	1 U	1 U	0.0
1 1 2-TRICHLOROETHANE	0.5 U			0.5 U	0.5 U	1 U	1 U	0.0
TETRACHLOROETHENE	0.5 U			0.5 U	0.5 U	1 U	1 U	0.0
2-HEXANONE	10 U			10 U	10 U	10 U	10 U	0.0
DIBROMOCHLOROMETHANE	0.5 U			0.5 U	0.5 U	1 U	1 U	0.0
CHLOROBENZENE	0.5 U			0.5 U	0.5 U	1 U	1 U	0.0
ETHYLBENZENE	0.5 U			0.5 U	0.5 U	1 U	1 U	0.0
P-XYLENE/M-XYLENE	0.5 U			0.5 U	0.5 U	1 U	1 U	0.0
O-XYLENE	0.5 U			0.5 U	0.5 U	1 U	1 U	0.0
STYRENE	0.5 U			0.5 U	0.5 U	1 U	1 U	0.0
BROMOFORM	0.5 U			0.5 U	0.5 U	1 U	1 U	0.0
1 1 2 2-TETRACHLOROETHANE	0.5 U			0.5 U	0.5 U	1 U	1 U	0.0

**NOTES:**

U = Below Practical Quantitation Limit (PQL)

Blank = Not sampled



WELL NUMBER 87-20(1)  
ANALYTICAL SAMPLING RESULTS  
(Concentrations in ug/L)

ANALYTE	4/20/93	7/20/93	10/13/93	1/21/94	4/94	7/20/94	10/94	1/9/95	4/95	7/11/95	10/95	1/30/96	4/18/96	7/96
CHLOROMETHANE	5 U	125 U	5000 U	5 U		1000 U		250 U		1250 U		25 U	1000 U	
VINYL CHLORIDE	211	281	5000 U	207		1000 U		250 U		1250 U		340	1000 U	
CHLOROETHANE	5 U	125 U	5000 U	5 U		1000 U		250 U		1250 U		25 U	1000 U	
BROMOMETHANE	5 U	125 U	5000 U	5 U		1000 U		250 U		1250 U		25 U	1000 U	
1 1-DICHLOROETHENE	52	125 U	5000 U	17		1000 U		250 U		1250 U		51	1000 U	
ACETONE	50 U	1250 U	50000 U	50 U		10000 U		2500 U		12500 U		125 U	5000 U	
CARBON DISULFIDE	5 U	125 U	5000 U	5 U		1000 U		250 U		1250 U		25 U	1000 U	
METHYLENE CHLORIDE	2250	24800	15600	1250		2680		524		1250 U		1000	1000 U	
TRANS-1 2-DICHLOROETHENE	35	125 U	5000 U	27		1000 U		250 U		1250 U		110	1000 U	
1 1-DICHLOROETHANE	17	125 U	5000 U	33		1000 U		250 U		1250 U		35	1000 U	
CIS-1 2-DICHLOROETHENE	11400	21600	13700	1280		9360		5320		16800		21000	21000	
METHYL ETHYL KETONE	50 U	1250 U	50000 U	50 U		33700		2500 U		12500 U		125 U	5000 U	
CHLOROFORM	6	125 U	5000 U	9		1000 U		250 U		1250 U		25 U	1000 U	
1 1 1-TRICHLOROETHANE	5 U	595	5000 U	480		1000 U		250 U		1250 U		300	1000 U	
CARBON TETRACHLORIDE	24	125 U	5000 U	5 U		1000 U		250 U		1250 U		25 U	1000 U	
BENZENE	5 U	125 U	5000 U	5 U		1000 U		250 U		1250 U		25 U	1000 U	
1 2-DICHLOROETHANE	5 U	125 U	5000 U	5 U		1000 U		250 U		1250 U		25 U	1000 U	
TRICHLOROETHENE	24800	88500	51000	4140		38600		20400		28200		40000	24000	
1 2-DICHLOROPROPANE	42	125 U	5000 U	5 U		1000 U		250 U		1250 U		25 U	1000 U	
BROMODICHLOROMETHANE	5 U	125 U	5000 U	5 U		1000 U		250 U		1250 U		25 U	1000 U	
CIS-1 3-DICHLOROPROPENE	5 U	125 U	5000 U	5 U		1000 U		250 U		1250 U		25 U	1000 U	
MIBK	50 U	1250 U	50000 U	50 U		10000 U		2500 U		12500 U		125 U	2000 U	
TOLUENE	12	125 U	5000 U	16		1000 U		250 U		1250 U		25 U	1000 U	
TRANS-1 3-DICHLOROPROPENE	5 U	125 U	5000 U	5 U		1000 U		250 U		1250 U		25 U	1000 U	
1 1 2-TRICHLOROETHANE	5 U	125 U	5000 U	5 U		1000 U		250 U		1250 U		25 U	1000 U	
TETRACHLOROETHENE	6	328	5000 U	10		1000 U		250 U		1250 U		26	1000 U	
2-HEXANONE	50 U	1250 U	50000 U	50 U		10000 U		2500 U		12500 U		125 U	2000 U	
DIBROMOCHLOROMETHANE	5 U	125 U	5000 U	5 U		1000 U		250 U		1250 U		25 U	1000 U	
CHLOROBENZENE	5 U	125 U	5000 U	5 U		1000 U		250 U		1250 U		25 U	1000 U	
ETHYLBENZENE	5 U	125 U	5000 U	5 U		1000 U		250 U		1250 U		25 U	1000 U	
P-XYLENE/M-XYLENE	5 U	125 U	5000 U	5 U		1000 U		250 U		1250 U		25 U	1000 U	
O-XYLENE	5 U	125 U	5000 U	5 U		1000 U		250 U		1250 U		25 U	1000 U	
STYRENE	5 U	125 U	5000 U	5 U		1000 U		250 U		1250 U		25 U	1000 U	
BROMOFORM	5 U	125 U	5000 U	5 U		1000 U		250 U		1250 U		25 U	1000 U	
1 1 2 2-TETRACHLOROETHANE	5 U	125 U	5000 U	5 U		1000 U		250 U		1250 U		25 U	1000 U	

## NOTES:

U = Below Practical Quantitation Limit (PQL)

Blank = Not sampled

WELL NUMBER 87-20(1)  
ANALYTICAL SAMPLING RESULTS  
(Concentrations in ug/L)

ANALYTE	10/17/96	1/97	4/29/97	7/97	10/29/97	4/20/98	10/28/98	AVG
CHLOROMETHANE	1000 U		500 U		1200 U	100 U	200 U	0.0
VINYL CHLORIDE	1000 U		500 U		1200 U	720	200 U	125.6
CHLOROETHANE	1000 U		500 U		1200 U	100 U	200 U	0.0
BROMOMETHANE	1000 U		500 U		1200 U	100 U	200 U	0.0
1 1-DICHLOROETHENE	1000 U		500 U		1200 U	100 U	200 U	8.6
ACETONE	5000 U		2500 U		6200 U	1000 U	2000 U	0.0
CARBON DISULFIDE	1000 U		500 U		1200 U	100 U	200 U	0.0
METHYLENE CHLORIDE	1000 U		500 U		1200 U	200 U	200 U	2321.7
TRANS-1 2-DICHLOROETHENE	1000 U		500 U		1200 U	100 U	200 U	12.3
1 1-DICHLOROETHANE	1000 U		500 U		1200 U	100 U	200 U	6.1
CIS-1 2-DICHLOROETHENE	11000		14000		12000	9700	11000	12797.1
METHYL ETHYL KETONE	13000		2500 U		6200 U	1000 U	2000 U	3335.7
CHLOROFORM	1000 U		500 U		1200 U	100 U	200 U	1.1
1 1 1-TRICHLOROETHANE	1000 U		500 U		1200 U	100 U	200 U	98.2
CARBON TETRACHLORIDE	1000 U		500 U		1200 U	100 U	200 U	1.7
BENZENE	1000 U		500 U		1200 U	70 U	140 U	0.0
1 2-DICHLOROETHANE	1000 U		500 U		1200 U	100 U	200 U	0.0
TRICHLOROETHENE	6000		4000		2800	430	1800	23905.0
1 2-DICHLOROPROPANE	1000 U		500 U		1200 U	100 U	200 U	3.0
BROMODICHLOROMETHANE	1000 U		500 U		1200 U	100 U	200 U	0.0
CIS-1 3-DICHLOROPROPENE	1000 U		500 U		1200 U	100 U	200 U	0.0
MIBK	2000 U		1000 U		2500 U	1000 U	2000 U	0.0
TOLUENE	1000 U		500 U		1200 U	100 U	200 U	2.0
TRANS-1 3-DICHLOROPROPENE	1000 U		500 U		1200 U	100 U	200 U	0.0
1 1 2-TRICHLOROETHANE	1000 U		500 U		1200 U	100 U	200 U	0.0
TETRACHLOROETHENE	1000 U		500 U		1200 U	100 U	200 U	26.4
2-HEXANONE	2000 U		1000 U		2500 U	1000 U	2000 U	0.0
DIBROMOCHLOROMETHANE	1000 U		500 U		1200 U	100 U	200 U	0.0
CHLOROBENZENE	1000 U		500 U		1200 U	100 U	200 U	0.0
ETHYLBENZENE	1000 U		500 U		1200 U	100 U	200 U	0.0
P-XYLENE/M-XYLENE	1000 U		500 U		1200 U	100 U	200 U	0.0
O-XYLENE	1000 U		500 U		1200 U	100 U	200 U	0.0
STYRENE	1000 U		500 U		1200 U	100 U	200 U	0.0
BROMOFORM	1000 U		500 U		1200 U	100 U	200 U	0.0
1 1 2 2-TETRACHLOROETHANE	1000 U		500 U		1200 U	100 U	200 U	0.0

**NOTES:**

U = Below Practical Quantitation Limit (PQL)

Blank = Not sampled

WELL NUMBER 87-21(1)  
ANALYTICAL SAMPLING RESULTS  
(Concentrations in ug/L)

ANALYTE	4/20/93	7/20/93	10/13/93	1/20/94	4/94	7/20/94	10/94	1/11/95	4/95	7/11/95	10/95	1/29/96	4/18/96	7/96
CHLOROMETHANE	5 U	5 U	125 U	5 U		50 U		50 U		25 U		25 U	25 U	
VINYL CHLORIDE	5 U	5 U	125 U	5 U		50 U		50 U		25 U		25 U	25 U	
CHLOROETHANE	5 U	5 U	125 U	5 U		50 U		50 U		25 U		25 U	25 U	
BROMOMETHANE	5 U	5 U	125 U	5 U		50 U		50 U		25 U		25 U	25 U	
1 1-DICHLOROETHENE	5 U	5 U	125 U	5 U		50 U		50 U		25 U		25 U	25 U	
ACETONE	50 U	50 U	1250 U	50 U		500 U		500 U		250 U		125 U	125 U	
CARBON DISULFIDE	5 U	5 U	125 U	5 U		50 U		50 U		25 U		25 U	25 U	
METHYLENE CHLORIDE	5 U	5 U	125 U	5 U		50 U		50 U		25 U		25 U	25 U	
TRANS-1 2-DICHLOROETHENE	5 U	5 U	125 U	6		50 U		50 U		25 U		25 U	25 U	
1 1-DICHLOROETHANE	5 U	7	125 U	6		50 U		50 U		25 U		25 U	25 U	
CIS-1 2-DICHLOROETHENE	565	1720	802	1000		999		575		739		270	160	
METHYL ETHYL KETONE	50 U	50 U	1250 U	50 U		500 U		500 U		250 U		125 U	125 U	
CHLOROFORM	5 U	5 U	125 U	5 U		50 U		50 U		25 U		25 U	25 U	
1 1 1-TRICHLOROETHANE	22	67	125 U	36		50 U		50 U		25 U		25 U	25 U	
CARBON TETRACHLORIDE	5 U	5 U	125 U	5 U		50 U		50 U		25 U		25 U	25 U	
BENZENE	5 U	5 U	125 U	5 U		50 U		50 U		25 U		25 U	25 U	
1 2-DICHLOROETHANE	5 U	5 U	125 U	5 U		50 U		50 U		25 U		25 U	25 U	
TRICHLOROETHENE	200	1240	375	590		431		225		247		50	28	
1 2-DICHLOROPROPANE	5 U	5 U	125 U	5 U		50 U		50 U		25 U		25 U	25 U	
BROMODICHLOROMETHANE	5 U	5 U	125 U	5 U		50 U		50 U		25 U		25 U	25 U	
CIS-1 3-DICHLOROPROPENE	5 U	5 U	125 U	5 U		50 U		50 U		25 U		25 U	25 U	
MIBK	50 U	50 U	1250 U	50 U		500 U		500 U		250 U		125 U	50 U	
TOLUENE	5 U	5 U	125 U	5 U		50 U		50 U		25 U		25 U	25 U	
TRANS-1 3-DICHLOROPROPENE	5 U	5 U	125 U	5 U		50 U		50 U		25 U		25 U	25 U	
1 1 2-TRICHLOROETHANE	5 U	5 U	125 U	5 U		50 U		50 U		25 U		25 U	25 U	
TETRACHLOROETHENE	5 U	5 U	125 U	5 U		50 U		50 U		25 U		25 U	25 U	
2-HEXANONE	50 U	50 U	1250 U	50 U		500 U		500 U		250 U		125 U	50 U	
DIBROMOCHLOROMETHANE	5 U	5 U	125 U	5 U		50 U		50 U		25 U		25 U	25 U	
CHLOROBENZENE	5 U	5 U	125 U	5 U		50 U		50 U		25 U		25 U	25 U	
ETHYLBENZENE	5 U	5 U	125 U	5 U		50 U		50 U		25 U		25 U	25 U	
P-XYLENE/M-XYLENE	5 U	5 U	125 U	5 U		50 U		50 U		25 U		25 U	25 U	
O-XYLENE	5 U	5 U	125 U	5 U		50 U		50 U		25 U		25 U	25 U	
STYRENE	5 U	5 U	125 U	5 U		50 U		50 U		25 U		25 U	25 U	
BROMOFORM	5 U	5 U	125 U	5 U		50 U		50 U		25 U		25 U	25 U	
1 1 2 2-TETRACHLOROETHANE	5 U	5 U	125 U	5 U		50 U		50 U		25 U		25 U	25 U	

## NOTES:

U = Below Practical Quantitation Limit (PQL)

Blank = Not sampled

WELL NUMBER 87-21(1)  
ANALYTICAL SAMPLING RESULTS  
(Concentrations in ug/L)

ANALYTE	10/15/96	1/97	4/29/97	7/97	10/28/97	4/20/98	10/27/98	AVG
CHLOROMETHANE	5 U		2.5 U		5 U	20 U	10 U	0.0
VINYL CHLORIDE	5 U		4		130	20 U	54	13.4
CHLOROETHANE	5 U		2.5 U		5 U	20 U	10 U	0.0
BROMOMETHANE	5 U		2.5 U		5 U	20 U	10 U	0.0
1 1-DICHLOROETHENE	5 U		2.5 U		6	20 U	10 U	0.4
ACETONE	25 U		50 U		25 U	200 U	100 U	0.0
CARBON DISULFIDE	5 U		2.5 U		5 U	20 U	10 U	0.0
METHYLENE CHLORIDE	5 U		2.5 U		5 U	40 U	10 U	0.0
TRANS-1 2-DICHLOROETHENE	5 U		2.5 U		9	20 U	10 U	1.1
1 1-DICHLOROETHANE	5 U		2.5 U		5 U	20 U	10 U	0.9
CIS-1 2-DICHLOROETHENE	340		160		2100	37	1200	761.9
METHYL ETHYL KETONE	25 U		50 U		25 U	200 U	100 U	0.0
CHLOROFORM	5 U		2.5 U		5 U	20 U	10 U	0.0
1 1 1-TRICHLOROETHANE	6		2.5 U		10	20 U	10 U	10.1
CARBON TETRACHLORIDE	5 U		2.5 U		5 U	20 U	10 U	0.0
BENZENE	5 U		2.5 U		5 U	14 U	7 U	0.0
1 2-DICHLOROETHANE	5 U		2.5 U		5 U	20 U	10 U	0.0
TRICHLOROETHENE	53		15		99	20 U	700	303.8
1 2-DICHLOROPROPANE	5 U		2.5 U		5 U	20 U	10 U	0.0
BROMODICHLOROMETHANE	5 U		2.5 U		5 U	20 U	10 U	0.0
CIS-1 3-DICHLOROPROPENE	5 U		2.5 U		5 U	20 U	10 U	0.0
MIBK	10 U		50 U		10 U	200 U	100 U	0.0
TOLUENE	5 U		2.5 U		5 U	20 U	10 U	0.0
TRANS-1 3-DICHLOROPROPENE	5 U		2.5 U		5 U	20 U	10 U	0.0
1 1 2-TRICHLOROETHANE	5 U		2.5 U		5 U	20 U	10 U	0.0
TETRACHLOROETHENE	5 U		2.5 U		5 U	20 U	10 U	0.0
2-HEXANONE	10 U		50 U		10 U	200 U	100 U	0.0
DIBROMOCHLOROMETHANE	5 U		2.5 U		5 U	20 U	10 U	0.0
CHLOROBENZENE	5 U		2.5 U		5 U	20 U	10 U	0.0
ETHYLBENZENE	5 U		2.5 U		5 U	20 U	10 U	0.0
P-XYLENE/M-XYLENE	5 U		2.5 U		5 U	20 U	10 U	0.0
O-XYLENE	5 U		2.5 U		5 U	20 U	10 U	0.0
STYRENE	5 U		2.5 U		5 U	20 U	10 U	0.0
BROMOFORM	5 U		2.5 U		5 U	20 U	10 U	0.0
1 1 2 2-TETRACHLOROETHANE	5 U		2.5 U		5 U	20 U	10 U	0.0

## NOTES:

U = Below Practical Quantitation Limit (PQL)

Blank = Not sampled

WELL NUMBER 87-22(0)  
 ANALYTICAL SAMPLING RESULTS  
 (Concentrations in ug/L)

ANALYTE	4/93	7/93	10/93	1/94	4/94	7/94	10/94	1/95	4/95	7/95	10/95	1/31/96	4/18/96	7/96	10/96	1/97
CHLOROMETHANE												0.5 U	0.5 U			
VINYL CHLORIDE												0.5 U	0.5 U			
CHLOROETHANE												0.5 U	0.5 U			
BROMOMETHANE												0.5 U	0.5 U			
1 1-DICHLOROETHENE												0.5 U	0.5 U			
ACETONE												10 U	10 U			
CARBON DISULFIDE												0.5 U	0.5 U			
METHYLENE CHLORIDE												0.5 U	0.5 U			
TRANS-1 2-DICHLOROETHENE												0.5 U	0.5 U			
1 1-DICHLOROETHANE												0.5 U	0.5 U			
CIS-1 2-DICHLOROETHENE												0.5 U	0.5 U			
METHYL ETHYL KETONE												10 U	10 U			
CHLOROFORM												0.5 U	0.5 U			
1 1 1-TRICHLOROETHANE												0.5 U	0.5 U			
CARBON TETRACHLORIDE												0.5 U	0.5 U			
BENZENE												0.5 U	0.5 U			
1 2-DICHLOROETHANE												0.5 U	0.5 U			
TRICHLOROETHENE												0.5 U	0.5 U			
1 2-DICHLOROPROPANE												0.5 U	0.5 U			
BROMODICHLOROMETHANE												0.5 U	0.5 U			
CIS-1 3-DICHLOROPROPENE												0.5 U	0.5 U			
MIBK												10 U	10 U			
TOLUENE												0.5 U	0.5 U			
TRANS-1 3-DICHLOROPROPENE												0.5 U	0.5 U			
1 1 2-TRICHLOROETHANE												0.5 U	0.5 U			
TETRACHLOROETHENE												0.5 U	0.5 U			
2-HEXANONE												10 U	10 U			
DIBROMOCHLOROMETHANE												0.5 U	0.5 U			
CHLOROBENZENE												0.5 U	0.5 U			
ETHYLBENZENE												0.5 U	0.5 U			
P-XYLENE/M-XYLENE												0.5 U	0.5 U			
O-XYLENE												0.5 U	0.5 U			
STYRENE												0.5 U	0.5 U			
BROMOFORM												0.5 U	0.5 U			
1 1 2 2-TETRACHLOROETHANE												1 U	1 U			

NOTES:

Blank = Not sampled

WELL NUMBER 87-22(0)  
 ANALYTICAL SAMPLING RESULTS  
 (Concentrations in ug/L)

ANALYTE	4/30/97	7/97	10/97	4/20/98	10/98	AVG
CHLOROMETHANE	0.5 U			1 U		0.0
VINYL CHLORIDE	0.5 U			1 U		0.0
CHLOROETHANE	0.5 U			1 U		0.0
BROMOMETHANE	0.5 U			1 U		0.0
1 1-DICHLOROETHENE	0.5 U			1 U		0.0
ACETONE	10 U			10 U		0.0
CARBON DISULFIDE	0.5 U			1 U		0.0
METHYLENE CHLORIDE	0.5 U			2 U		0.0
TRANS-1 2-DICHLOROETHENE	0.5 U			1 U		0.0
1 1-DICHLOROETHANE	0.5 U			1 U		0.0
CIS-1 2-DICHLOROETHENE	0.5 U			1 U		0.0
METHYL ETHYL KETONE	10 U			10 U		0.0
CHLOROFORM	0.5 U			1 U		0.0
1 1 1-TRICHLOROETHANE	0.5 U			1 U		0.0
CARBON TETRACHLORIDE	0.5 U			1 U		0.0
BENZENE	0.5 U			0.7 U		0.0
1 2-DICHLOROETHANE	0.5 U			1 U		0.0
TRICHLOROETHENE	0.5 U			1 U		0.0
1 2-DICHLOROPROPANE	0.5 U			1 U		0.0
BROMODICHLOROMETHANE	0.5 U			1 U		0.0
CIS-1 3-DICHLOROPROPENE	0.5 U			1 U		0.0
MIBK	10 U			10 U		0.0
TOLUENE	0.5 U			1 U		0.0
TRANS-1 3-DICHLOROPROPENE	0.5 U			1 U		0.0
1 1 2-TRICHLOROETHANE	0.5 U			1 U		0.0
TETRACHLOROETHENE	0.5 U			1 U		0.0
2-HEXANONE	10 U			10 U		0.0
DIBROMOCHLOROMETHANE	0.5 U			1 U		0.0
CHLOROBENZENE	0.5 U			1 U		0.0
ETHYLBENZENE	0.5 U			1 U		0.0
P-XYLENE/M-XYLENE	0.5 U			1 U		0.0
O-XYLENE	0.5 U			1 U		0.0
STYRENE	0.5 U			1 U		0.0
BROMOFORM	0.5 U			1 U		0.0
1 1 2 2-TETRACHLOROETHANE	0.5 U			1 U		0.0

**NOTES:**

Blank = Not sampled

WELL NUMBER 87-22(1)  
 ANALYTICAL SAMPLING RESULTS  
 (Concentrations in ug/L)

ANALYTE	4/93	7/93	10/93	1/20/94	4/27/94	7/20/94	10/25/94	1/12/95	4/19/95	7/12/95	10/18/95	1/31/96	4/18/96
CHLOROMETHANE				5 U	125 U	250 U	250 U	250 U	250 U	250 U	250 U	250 U	250 U
VINYL CHLORIDE				114	200	274	250 U	250 U	250 U	250 U	390	260	250 U
CHLOROETHANE				5 U	125 U	250 U	250 U	250 U	250 U	250 U	250 U	250 U	250 U
BROMOMETHANE				5 U	125 U	250 U	250 U	250 U	250 U	250 U	250 U	250 U	250 U
1 1-DICHLOROETHENE				5 U	125 U	250 U	250 U	250 U	250 U	250 U	250 U	250 U	250 U
ACETONE				50 U	1250 U	2500 U	2500 U	2500 U	2500 U	2500 U	2500 U	1250 U	1250 U
CARBON DISULFIDE				7	125 U	250 U	250 U	250 U	250 U	250 U	250 U	250 U	250 U
METHYLENE CHLORIDE				5 U	125 U	250 U	250 U	250 U	250 U	250 U	250 U	250 U	250 U
TRANS-1 2-DICHLOROETHENE				12	125 U	250 U	250 U	250 U	250 U	250 U	250 U	250 U	250 U
1 1-DICHLOROETHANE				5 U	125 U	250 U	250 U	250 U	250 U	250 U	250 U	250 U	250 U
CIS-1 2-DICHLOROETHENE				2920	3830	6320	4530	7260	6810	4850	6900	6700	2900
METHYL ETHYL KETONE				50 U	1250 U	2500 U	2500 U	2500 U	2500 U	2500 U	2500 U	1250 U	1250 U
CHLOROFORM				5 U	125 U	250 U	250 U	250 U	250 U	250 U	250 U	250 U	250 U
1 1 1-TRICHLOROETHANE				14	1010	250 U	250 U	250 U	250 U	250 U	250 U	250 U	250 U
CARBON TETRACHLORIDE				5 U	125 U	250 U	250 U	250 U	250 U	250 U	250 U	250 U	250 U
BENZENE				5 U	125 U	250 U	250 U	250 U	250 U	250 U	250 U	250 U	250 U
1 2-DICHLOROETHANE				5 U	125 U	250 U	250 U	250 U	250 U	250 U	250 U	250 U	250 U
TRICHLOROETHENE				2580	2850	6080	2710	4023	3510	2190	2900	3100	1200
1 2-DICHLOROPROPANE				5 U	125 U	250 U	250 U	250 U	250 U	250 U	250 U	250 U	250 U
BROMODICHLOROMETHANE				5 U	125 U	250 U	250 U	250 U	250 U	250 U	250 U	250 U	250 U
CIS-1 3-DICHLOROPROPENE				5 U	125 U	250 U	250 U	250 U	250 U	250 U	250 U	250 U	250 U
MIBK				50 U	1250 U	2500 U	2500 U	2500 U	2500 U	2500 U	2500 U	1250 U	500 U
TOLUENE				5 U	456	250 U	250 U	250 U	250 U	250 U	250 U	250 U	250 U
TRANS-1 3-DICHLOROPROPENE				5 U	125 U	250 U	250 U	250 U	250 U	250 U	250 U	250 U	250 U
1 1 2-TRICHLOROETHANE				5 U	125 U	250 U	250 U	250 U	250 U	250 U	250 U	250 U	250 U
TETRACHLOROETHENE				5 U	125 U	250 U	250 U	250 U	250 U	250 U	250 U	250 U	250 U
2-HEXANONE				50 U	1250 U	2500 U	2500 U	2500 U	2500 U	2500 U	2500 U	1250 U	500 U
DIBROMOCHLOROMETHANE				5 U	125 U	250 U	250 U	250 U	250 U	250 U	250 U	250 U	250 U
CHLOROBENZENE				5 U	125 U	250 U	250 U	250 U	250 U	250 U	250 U	250 U	250 U
ETHYLBENZENE				5 U	188	250 U	250 U	250 U	250 U	250 U	250 U	250 U	250 U
P-XYLENE/M-XYLENE				5 U	883	250 U	250 U	250 U	250 U	250 U	250 U	250 U	250 U
O-XYLENE				5 U	284	250 U	250 U	250 U	250 U	250 U	250 U	250 U	250 U
STYRENE				5 U	125 U	250 U	250 U	250 U	250 U	250 U	250 U	250 U	250 U
BROMOFORM				5 U	125 U	250 U	250 U	250 U	250 U	250 U	250 U	250 U	250 U
1 1 2 2-TETRACHLOROETHANE				5 U	125 U	250 U	250 U	250 U	250 U	250 U	250 U	250 U	250 U

NOTES:

U = Below Practical Quantitation Limit (PQL)

Blank = Not sampled

WELL NUMBER 87-22(1)  
ANALYTICAL SAMPLING RESULTS  
(Concentrations in ug/L)

ANALYTE	7/17/96	10/15/96	1/15/97	4/30/97	7/22/97	10/29/97	4/98	10/28/98	AVG
CHLOROMETHANE	125 U	120 U	120 U	120 U	5 U	120		130 U	7.1
VINYL CHLORIDE	170	120 U	120 U	180	50	250		130	118.7
CHLOROETHANE	125 U	120 U	120 U	120 U	5 U	100 U		130 U	0.0
BROMOMETHANE	125 U	120 U	120 U	120 U	5 U	100 U		130 U	0.0
1 1-DICHLOROETHENE	125 U	120 U	120 U	120 U	5 U	100 U		130 U	0.0
ACETONE	625 U	620 U	620 U	620 U	100 U	500 U		630 U	0.0
CARBON DISULFIDE	125 U	120 U	120 U	120 U	5 U	100 U		130 U	0.4
METHYLENE CHLORIDE	125 U	120 U	120 U	120 U	6	100 U		130 U	0.4
TRANS-1 2-DICHLOROETHENE	125 U	120 U	120 U	120 U	5	100 U		130 U	1.0
1 1-DICHLOROETHANE	125 U	120 U	120 U	120 U	5 U	100 U		130 U	0.0
CIS-1 2-DICHLOROETHENE	5400	3000	2400	3400	1000	4200		1800	4365.9
METHYL ETHYL KETONE	625 U	620 U	620 U	620 U	100 U	500 U		630 U	0.0
CHLOROFORM	125 U	120 U	120 U	120 U	5 U	100 U		130 U	0.0
1 1 1-TRICHLOROETHANE	125 U	120 U	120 U	120 U	5 U	100 U		130 U	60.2
CARBON TETRACHLORIDE	125 U	120 U	120 U	120 U	5 U	100 U		130 U	0.0
BENZENE	125 U	120 U	120 U	120 U	5 U	100 U		130 U	0.0
1 2-DICHLOROETHANE	125 U	120 U	120 U	120 U	5 U	100 U		130 U	0.0
TRICHLOROETHENE	1900	440	630	650	50	200		130 U	2059.6
1 2-DICHLOROPROPANE	125 U	120 U	120 U	120 U	5 U	100 U		130 U	0.0
BROMODICHLOROMETHANE	125 U	120 U	120 U	120 U	5 U	100 U		130 U	0.0
CIS-1 3-DICHLOROPROPENE	125 U	120 U	120 U	120 U	5 U	100 U		130 U	0.0
MIBK	250 U	250 U	250 U	250 U	100 U	200 U		250 U	0.0
TOLUENE	125 U	120 U	120 U	120 U	5 U	100 U		130 U	26.8
TRANS-1 3-DICHLOROPROPENE	125 U	120 U	120 U	120 U	5 U	100 U		130 U	0.0
1 1 2-TRICHLOROETHANE	125 U	120 U	120 U	120 U	5 U	100 U		130 U	0.0
TETRACHLOROETHENE	125 U	120 U	120 U	120 U	5 U	100 U		130 U	0.0
2-HEXANONE	250 U	250 U	250 U	250 U	100 U	200 U		250 U	0.0
DIBROMOCHLOROMETHANE	125 U	120 U	120 U	120 U	5 U	100 U		130 U	0.0
CHLOROBENZENE	125 U	120 U	120 U	120 U	5 U	100 U		130 U	0.0
ETHYLBENZENE	125 U	120 U	120 U	120 U	5 U	100 U		130 U	11.1
P-XYLENE/M-XYLENE	125 U	120 U	120 U	120 U	5 U	100 U		130 U	51.9
O-XYLENE	125 U	120 U	120 U	120 U	5 U	100 U		130 U	16.7
STYRENE	125 U	120 U	120 U	120 U	5 U	100 U		130 U	0.0
BROMOFORM	125 U	120 U	120 U	120 U	5 U	100 U		130 U	0.0
1 1 2 2-TETRACHLOROETHANE	125 U	120 U	120 U	120 U	5 U	100 U		130 U	0.0

**NOTES:**

U = Below Practical Quantitation Limit (PQL)

Blank = Not sampled



WELL NUMBER 87-23(0)  
ANALYTICAL SAMPLING RESULTS  
(Concentrations in ug/L)

ANALYTE	4/93	7/20/93	10/93	1/21/94	4/94	7/20/94	10/94	1/11/95	4/95	7/11/95	10/95	1/31/96	4/17/96	7/96
CHLOROMETHANE		0.5 U		0.5 U		1 U		0.5 U		1 U		0.5 U	0.5 U	
VINYL CHLORIDE		0.5 U		0.5 U		1 U		0.5 U		1 U		0.5 U	0.5 U	
CHLOROETHANE		0.5 U		0.5 U		1 U		0.5 U		1 U		0.5 U	0.5 U	
BROMOMETHANE		0.5 U		0.5 U		1 U		0.5 U		1 U		0.5 U	0.5 U	
1 1-DICHLOROETHENE		0.5 U		0.5 U		1 U		0.5 U		1 U		0.5 U	0.5 U	
ACETONE		20 U		50 U		10 U		10 U		10		10 U	10 U	
CARBON DISULFIDE		0.5 U		0.5 U		1 U		0.5 U		1 U		0.5 U	0.5 U	
METHYLENE CHLORIDE		0.5 U		0.5 U		1 U		0.5 U		1 U		0.5 U	0.5 U	
TRANS-1 2-DICHLOROETHENE		0.5 U		0.5 U		1 U		0.5 U		1 U		0.5 U	0.5 U	
1 1-DICHLOROETHANE		0.5 U		0.5 U		1 U		0.5 U		1 U		0.5 U	0.5 U	
CIS-1 2-DICHLOROETHENE		0.5 U		0.5 U		1 U		0.5 U		1 U		0.5 U	0.5 U	
METHYL ETHYL KETONE		20 U		50 U		10 U		10 U		10 U		10 U	10 U	
CHLOROFORM		0.5 U		0.5 U		1 U		0.5 U		1 U		0.5 U	0.5 U	
1 1 1-TRICHLOROETHANE		0.5 U		0.5 U		1 U		0.5 U		1 U		0.5 U	0.5 U	
CARBON TETRACHLORIDE		0.5 U		0.5 U		1 U		0.5 U		1 U		0.5 U	0.5 U	
BENZENE		0.5 U		0.5 U		1 U		0.5 U		1 U		0.5 U	0.5 U	
1 2-DICHLOROETHANE		0.5 U		0.5 U		1		0.5 U		1 U		0.5 U	0.5 U	
TRICHLOROETHENE		0.5 U		0.5 U		1 U		0.9		1 U		0.5 U	0.5 U	
1 2-DICHLOROPROPANE		0.5 U		0.5 U		1 U		0.5 U		1 U		0.5 U	0.5 U	
BROMODICHLOROMETHANE		0.5 U		0.5 U		1 U		0.5 U		1 U		0.5 U	0.5 U	
CIS-1 3-DICHLOROPROPENE		0.5 U		0.5 U		1 U		0.5 U		1 U		0.5 U	0.5 U	
MIBK		20 U		50 U		10 U		10 U		10 U		10 U	10 U	
TOLUENE		0.5 U		0.5 U		1 U		0.5 U		1 U		0.5 U	0.5 U	
TRANS-1 3-DICHLOROPROPENE		0.5 U		0.5 U		1 U		0.5 U		1 U		0.5 U	0.5 U	
1 1 2-TRICHLOROETHANE		0.5 U		0.5 U		1		0.5 U		1 U		0.5 U	0.5 U	
TETRACHLOROETHENE		0.5 U		0.5 U		1 U		0.5 U		1 U		0.5 U	0.5 U	
2-HEXANONE		20 U		50 U		10 U		10 U		10 U		10 U	10 U	
DIBROMOCHLOROMETHANE		0.5 U		0.5 U		2		0.5 U		1 U		0.5 U	0.5 U	
CHLOROBENZENE		0.5 U		0.5 U		1 U		0.5 U		1 U		0.5 U	0.5 U	
ETHYLBENZENE		0.5 U		0.5 U		1 U		0.5 U		1 U		0.5 U	0.5 U	
P-XYLENE/M-XYLENE		0.5 U		0.5 U		1 U		0.5 U		1 U		0.5 U	0.5 U	
O-XYLENE		0.5 U		0.5 U		1 U		0.5 U		1 U		0.5 U	0.5 U	
STYRENE		0.5 U		0.5 U		1 U		0.5 U		1 U		0.5 U	0.5 U	
BROMOFORM		0.5 U		0.5 U		3		0.5 U		1 U		0.5 U	0.5 U	
1 1 2 2-TETRACHLOROETHANE		0.5 U		0.5 U		1 U		0.5 U		1 U		1 U	1 U	

**NOTES:**

U = Below Practical Quantitation Limit (PQL)

Blank = Not sampled

WELL NUMBER 87-23(0)  
 ANALYTICAL SAMPLING RESULTS  
 (Concentrations in ug/L)

ANALYTE	10/16/96	1/97	4/30/97	7/97	10/29/97	4/20/98	10/28/98	AVG
CHLOROMETHANE	0.5 U		0.5 U		0.5 U	1 U	1 U	0.0
VINYL CHLORIDE	0.5 U		0.5 U		0.5 U	1 U	1 U	0.0
CHLOROETHANE	0.5 U		0.5 U		0.5 U	1 U	1 U	0.0
BROMOMETHANE	0.5 U		0.5 U		0.5 U	1 U	1 U	0.0
1 1-DICHLOROETHENE	0.5 U		0.5 U		0.5 U	1 U	1 U	0.0
ACETONE	10 U		10 U		10 U	10 U	10 U	0.8
CARBON DISULFIDE	0.5 U		0.5 U		0.5 U	1 U	1 U	0.0
METHYLENE CHLORIDE	0.5 U		0.5 U		0.5 U	2 U	1 U	0.0
TRANS-1 2-DICHLOROETHENE	0.5 U		0.5 U		0.5 U	1 U	1 U	0.0
1 1-DICHLOROETHANE	0.5 U		0.5 U		0.5 U	1 U	1 U	0.0
CIS-1 2-DICHLOROETHENE	0.5 U		0.5 U		0.5 U	1 U	1 U	0.0
METHYL ETHYL KETONE	10 U		10 U		10 U	10 U	10 U	0.0
CHLOROFORM	0.5 U		0.5 U		0.5 U	1 U	1 U	0.0
1 1 1-TRICHLOROETHANE	0.5 U		0.5 U		0.5 U	1 U	1 U	0.0
CARBON TETRACHLORIDE	0.5 U		0.5 U		0.5 U	1 U	1 U	0.0
BENZENE	0.5 U		0.5 U		0.5 U	0.7 U	0.700 U	0.0
1 2-DICHLOROETHANE	0.5 U		0.5 U		0.5 U	1 U	1 U	0.1
TRICHLOROETHENE	0.5 U		0.5 U		0.5 U	1 U	1 U	0.1
1 2-DICHLOROPROPANE	0.5 U		0.5 U		0.5 U	1 U	1 U	0.0
BROMODICHLOROMETHANE	0.5 U		0.5 U		0.5 U	1 U	1 U	0.0
CIS-1 3-DICHLOROPROPENE	0.5 U		0.5 U		0.5 U	1 U	1 U	0.0
MIBK	10 U		10 U		10 U	10 U	10 U	0.0
TOLUENE	0.5 U		0.5 U		0.5 U	1 U	1 U	0.0
TRANS-1 3-DICHLOROPROPENE	0.5 U		0.5 U		0.5 U	1 U	1 U	0.0
1 1 2-TRICHLOROETHANE	0.5 U		0.5 U		0.5 U	1 U	1 U	0.1
TETRACHLOROETHENE	0.5 U		0.5 U		0.5 U	1 U	1 U	0.0
2-HEXANONE	10 U		10 U		10 U	10 U	10 U	0.0
DIBROMOCHLOROMETHANE	0.5 U		0.5 U		0.5 U	1 U	1 U	0.2
CHLOROBENZENE	0.5 U		0.5 U		0.5 U	1 U	1 U	0.0
ETHYLBENZENE	0.5 U		0.5 U		0.5 U	1 U	1 U	0.0
P-XYLENE/M-XYLENE	0.5 U		0.5 U		0.5 U	1 U	1 U	0.0
O-XYLENE	0.5 U		0.5 U		0.5 U	1 U	1 U	0.0
STYRENE	0.5 U		0.5 U		0.5 U	1 U	1 U	0.0
BROMOFORM	0.5 U		0.5 U		0.5 U	1 U	1 U	0.3
1 1 2 2-TETRACHLOROETHANE	0.5 U		0.5 U		0.5 U	1 U	1 U	0.0

NOTES:

U = Below Practical Quantitation Limit (PQL)

Blank = Not sampled

WELL NUMBER 89-02(1)  
ANALYTICAL SAMPLING RESULTS  
(Concentrations in ug/L)

ANALYTE	4/93	7/93	10/93	3/94	4/28/94	7/21/94	10/26/94	1/11/95	4/19/95	7/11/95	10/18/95	1/31/96	4/19/96
CHLOROMETHANE					50 U	5 U	5 U	1000 U	2500 U	1000 U	500 U	500 U	1250 U
VINYL CHLORIDE					50 U	8	186	1000 U	2500 U	1000 U	500 U	500 U	1250 U
CHLOROETHANE					50 U	5 U	5 U	1000 U	2500 U	1000 U	500 U	500 U	1250 U
BROMOMETHANE					50 U	5 U	5 U	1000 U	2500 U	1000 U	500 U	500 U	1250 U
1 1-DICHLOROETHENE					50 U	5 U	5 U	1000 U	2500 U	1000 U	500 U	500 U	1250 U
ACETONE					500 U	50 U	50 U	10000 U	25000 U	10000 U	5000 U	2500 U	6250 U
CARBON DISULFIDE					50 U	5 U	5 U	1000 U	2500 U	1000 U	500 U	500 U	1250 U
METHYLENE CHLORIDE					1560	883	17200	10700	7110	1380	650	1400	1250 U
TRANS-1 2-DICHLOROETHENE					50 U	5 U	36	1000 U	2500 U	1000 U	500 U	500 U	1250 U
1 1-DICHLOROETHANE					50 U	5 U	58	1000 U	2500 U	1000 U	500 U	500 U	1250 U
CIS-1 2-DICHLOROETHENE					785	447	11700	9090	12000	6860	3400	16000	16000
METHYL ETHYL KETONE					500 U	50 U	50 U	10000 U	25000 U	10000 U	5000 U	2500 U	6250 U
CHLOROFORM					50 U	5 U	5 U	1000 U	2500 U	1000 U	500 U	500 U	1250 U
1 1 1-TRICHLOROETHANE					50 U	5 U	1160	1000 U	2500 U	1000 U	500 U	500 U	1250 U
CARBON TETRACHLORIDE					50 U	5 U	175	1000 U	2500 U	1000 U	500 U	500 U	1250 U
BENZENE					50 U	5 U	5 U	1000 U	2500 U	1000 U	500 U	500 U	1250 U
1 2-DICHLOROETHANE					50 U	5 U	5 U	1000 U	2500 U	1000 U	500 U	500 U	1250 U
TRICHLOROETHENE					1960	3530	84000	54900	49800	17200	8300	30000	18000
1 2-DICHLOROPROPANE					50 U	5 U	5 U	1000 U	2500 U	1000 U	500 U	500 U	1250 U
BROMODICHLOROMETHANE					50 U	5 U	5 U	1000 U	2500 U	1000 U	500 U	500 U	1250 U
CIS-1 3-DICHLOROPROPENE					50 U	5 U	5 U	1000 U	2500 U	1000 U	500 U	500 U	1250 U
MIBK					500 U	50 U	50 U	10000 U	25000 U	10000 U	5000 U	2500 U	2500 U
TOLUENE					50 U	5 U	33	1000 U	2500 U	1000 U	500 U	500 U	1250 U
TRANS-1 3-DICHLOROPROPENE					50 U	5 U	5 U	1000 U	2500 U	1000 U	500 U	500 U	1250 U
1 1 2-TRICHLOROETHANE					50 U	5 U	5 U	1000 U	2500 U	1000 U	500 U	500 U	1250 U
TETRACHLOROETHENE					50 U	5 U	5 U	1000 U	2500 U	1000 U	500 U	500 U	1250 U
2-HEXANONE					500 U	50 U	50 U	10000 U	25000 U	10000 U	5000 U	2500 U	2500 U
DIBROMOCHLOROMETHANE					50 U	5 U	5 U	1000 U	2500 U	1000 U	500 U	500 U	1250 U
CHLOROBENZENE					50 U	5 U	5 U	1000 U	2500 U	1000 U	500 U	500 U	1250 U
ETHYLBENZENE					50 U	5 U	5 U	1000 U	2500 U	1000 U	500 U	500 U	1250 U
P-XYLENE/M-XYLENE					50 U	5 U	5 U	1000 U	2500 U	1000 U	500 U	500 U	1250 U
O-XYLENE					50 U	5 U	5 U	1000 U	2500 U	1000 U	500 U	500 U	1250 U
STYRENE					50 U	5 U	5 U	1000 U	2500 U	1000 U	500 U	500 U	1250 U
BROMOFORM					50 U	5 U	5 U	1000 U	2500 U	1000 U	500 U	500 U	1250 U
1 1 2 2-TETRACHLOROETHANE					50 U	5 U	5 U	1000 U	2500 U	1000 U	500 U	500 U	1250 U

## NOTES:

U = Below Practical Quantitation Limit (PQL)

Blank = Not sampled

WELL NUMBER 89-02(1)  
ANALYTICAL SAMPLING RESULTS  
(Concentrations in ug/L)

ANALYTE	7/17/96	11/5/96	1/15/97	4/29/97	7/22/97	10/30/97	4/98	10/28/98	AVG
CHLOROMETHANE	500 U	50 U	250 U	500 U	0.5 U	5 U		10 U	0.0
VINYL CHLORIDE	500 U	50 U	250 U	500 U	50	50		81	23.4
CHLOROETHANE	500 U	50 U	250 U	500 U	0.5 U	5 U		10 U	0.0
BROMOMETHANE	500 U	50 U	250 U	500 U	0.5 U	5 U		10 U	0.0
1 1-DICHLOROETHENE	500 U	50 U	250 U	500 U	1	5 U		10 U	0.1
ACETONE	2500 U	500 U	1200 U	2500 U	10 U	25 U		100 U	0.0
CARBON DISULFIDE	500 U	50 U	250 U	500 U	0.5 U	5 U		10 U	0.0
METHYLENE CHLORIDE	500 U	50 U	250 U	500 U	0.5 U	5 U		10 U	2555.2
TRANS-1 2-DICHLOROETHENE	500 U	50 U	250 U	500 U	3	5 U		10 U	2.4
1 1-DICHLOROETHANE	500 U	50 U	250 U	500 U	9	9		10 U	4.8
CIS-1 2-DICHLOROETHENE	6900	6910	9700	11000	110	180		710	6987.0
METHYL ETHYL KETONE	2500 U	500 U	1200 U	2500 U	10 U	25 U		100 U	0.0
CHLOROFORM	500 U	50 U	250 U	500 U	5	5 U		10 U	0.3
1 1 1-TRICHLOROETHANE	500 U	50 U	250 U	500 U	2	5 U		10 U	72.6
CARBON TETRACHLORIDE	500 U	50 U	250 U	500 U	0.5 U	5 U		10 U	10.9
BENZENE	500 U	50 U	250 U	500 U	0.5 U	5 U		7 U	0.0
1 2-DICHLOROETHANE	500 U	50 U	250 U	500 U	0.5 U	5 U		10 U	0.0
TRICHLOROETHENE	6100	5030	6000	7000	9	84		260	18260.8
1 2-DICHLOROPROPANE	500 U	50 U	250 U	500 U	0.5 U	5 U		10 U	0.0
BROMODICHLOROMETHANE	500 U	50 U	250 U	500 U	0.5 U	5 U		10 U	0.0
CIS-1 3-DICHLOROPROPENE	500 U	50 U	250 U	500 U	0.5 U	5 U		10 U	0.0
MIBK	1000 U	500 U	500 U	1000 U	10 U	10 U		100 U	0.0
TOLUENE	500 U	50 U	250 U	500 U	0.5 U	5 U		10 U	2.1
TRANS-1 3-DICHLOROPROPENE	500 U	50 U	250 U	500 U	0.5 U	5 U		10 U	0.0
1 1 2-TRICHLOROETHANE	500 U	50 U	250 U	500 U	0.5 U	5 U		10 U	0.0
TETRACHLOROETHENE	500 U	50 U	250 U	500 U	0.5 U	5 U		10 U	0.0
2-HEXANONE	1000 U	500 U	500 U	1000 U	10 U	10 U		100 U	0.0
DIBROMOCHLOROMETHANE	500 U	50 U	250 U	500 U	0.5 U	5 U		10 U	0.0
CHLOROBENZENE	500 U	50 U	250 U	500 U	0.5 U	5 U		10 U	0.0
ETHYLBENZENE	500 U	50 U	250 U	500 U	0.5 U	5 U		10 U	0.0
P-XYLENE/M-XYLENE	500 U	50 U	250 U	500 U	0.5 U	5 U		10 U	0.0
O-XYLENE	500 U	50 U	250 U	500 U	0.5 U	5 U		10 U	0.0
STYRENE	500 U	50 U	250 U	500 U	0.5 U	5 U		10 U	0.0
BROMOFORM	500 U	50 U	250 U	500 U	0.5 U	5 U		10 U	0.0
1 1 2 2-TETRACHLOROETHANE	500 U	50 U	250 U	500 U	0.5 U	5 U		10 U	0.0

NOTES:

U = Below Practical Quantitation Limit (PQL)

Blank = Not sampled

WELL NUMBER 89-02(3)  
ANALYTICAL SAMPLING RESULTS  
(Concentrations in ug/L)

ANALYTE	4/93	7/21/93	10/93	1/18/94	4/27/94	7/21/94	10/26/94	1/11/95	4/19/95	7/11/95	10/18/95	1/31/96	4/19/96
CHLOROMETHANE		0.5 U		0.5 U	0.5 U	1 U	1 U	0.5 U	1 U	1 U	1 U	0.5 U	0.5 U
VINYL CHLORIDE		0.5 U		0.5 U	0.5 U	1 U	1 U	0.5 U	1 U	1 U	1 U	0.5 U	0.5 U
CHLOROETHANE		0.5 U		0.5 U	0.5 U	1 U	1 U	0.5 U	1 U	1 U	1 U	0.5 U	0.5 U
BROMOMETHANE		0.5 U		0.5 U	0.5 U	1 U	1 U	0.5 U	1 U	1 U	1 U	0.5 U	0.5 U
1 1-DICHLOROETHENE		0.5 U		0.5 U	0.5 U	1 U	1 U	0.5 U	1 U	1 U	1 U	0.5 U	0.5 U
ACETONE		29		50 U	10 U	10 U	10 U	10 U	10 U	10	10 U	10 U	10 U
CARBON DISULFIDE		2 J		0.5 U	2	1 U	1 U	2	1	1 U	2	1	12
METHYLENE CHLORIDE		0.5 U		0.5 U	0.5 U	1 U	1 U	0.5 U	1 U	1 U	1 U	0.5 U	0.5 U
TRANS-1 2-DICHLOROETHENE		0.5 U		0.5 U	0.5 U	1 U	1 U	0.5 U	1 U	1 U	1 U	0.5 U	0.5 U
1 1-DICHLOROETHANE		0.5 U		0.5 U	0.5 U	1 U	1 U	0.5 U	1 U	1 U	1 U	0.5 U	0.5 U
CIS-1 2-DICHLOROETHENE		0.5 U		0.5 U	0.5 U	1 U	1 U	0.5 U	1 U	1 U	1 U	0.5 U	0.5 U
METHYL ETHYL KETONE		20 U		50 U	10 U	10 U	10 U	10 U	10 U	10 U	10 U	10 U	10 U
CHLOROFORM		0.5 U		0.5 U	0.5 U	1 U	1 U	0.5 U	1 U	1 U	1 U	0.5 U	0.5 U
1 1 1-TRICHLOROETHANE		0.5 U		0.5 U	0.5 U	1 U	1 U	0.5 U	1 U	1 U	1 U	0.5 U	0.5 U
CARBON TETRACHLORIDE		0.5 U		0.5 U	0.5 U	1 U	1 U	0.5 U	1 U	1 U	1 U	0.5 U	0.5 U
BENZENE		0.5 U		0.5 U	0.5 U	1 U	1 U	0.5 U	1 U	1 U	1 U	0.5 U	0.5 U
1 2-DICHLOROETHANE		0.5 U		0.5 U	0.5 U	1 U	1 U	0.5 U	1 U	1 U	1 U	0.5 U	0.5 U
TRICHLOROETHENE		0.5 U		0.5 U	0.5 U	1 U	1 U	0.5 U	1 U	1 U	1 U	0.5 U	0.5 U
1 2-DICHLOROPROPANE		0.5 U		0.5 U	0.5 U	1 U	1 U	0.5 U	1 U	1 U	1 U	0.5 U	0.5 U
BROMODICHLOROMETHANE		0.5 U		0.5 U	0.5 U	1 U	1 U	0.5 U	1 U	1 U	1 U	0.5 U	0.5 U
CIS-1 3-DICHLOROPROPENE		0.5 U		0.5 U	0.5 U	1 U	1 U	0.5 U	1 U	1 U	1 U	0.5 U	0.5 U
MIBK		20 U		50 U	10 U	10 U	10 U	10 U	10 U	10 U	10 U	10 U	10 U
TOLUENE		0.5 U		0.5 U	0.5 U	1 U	1 U	0.5 U	1 U	1 U	1 U	0.5 U	0.5 U
TRANS-1 3-DICHLOROPROPENE		0.5 U		0.5 U	0.5 U	1 U	1 U	0.5 U	1 U	1 U	1 U	0.5 U	0.5 U
1 1 2-TRICHLOROETHANE		0.5 U		0.5 U	0.5 U	1 U	1 U	0.5 U	1 U	1 U	1 U	0.5 U	0.5 U
TETRACHLOROETHENE		0.5 U		0.5 U	0.5 U	1 U	1 U	0.5 U	1 U	1 U	1 U	0.5 U	0.5 U
2-HEXANONE		20 U		50 U	10 U	10 U	10 U	10 U	10 U	10 U	10 U	10 U	10 U
DIBROMOCHLOROMETHANE		0.5 U		0.5 U	0.5 U	1 U	1 U	0.5 U	1 U	1 U	1 U	0.5 U	0.5 U
CHLOROBENZENE		0.5 U		0.5 U	0.5 U	1 U	1 U	0.5 U	1 U	1 U	1 U	0.5 U	0.5 U
ETHYLBENZENE		0.5 U		0.5 U	0.5 U	1 U	1 U	0.5 U	1 U	1 U	1 U	0.5 U	0.5 U
P-XYLENE/M-XYLENE		0.5 U		0.5 U	0.5 U	1 U	1 U	0.5 U	1 U	1 U	1 U	0.5 U	0.5 U
O-XYLENE		0.5 U		0.5 U	0.5 U	1 U	1 U	0.5 U	1 U	1 U	1 U	0.5 U	0.5 U
STYRENE		0.5 U		0.5 U	0.5 U	1 U	1 U	0.5 U	1 U	1 U	1 U	0.5 U	0.5 U
BROMOFORM		0.5 U		0.5 U	0.5 U	1 U	1 U	0.5 U	1 U	1 U	1 U	0.5 U	0.5 U
1 1 2 2-TETRACHLOROETHANE		0.5 U		0.5 U	0.5 U	1 U	1 U	0.5 U	1 U	1 U	1 U	1 U	1 U

## NOTES:

U = Below Practical Quantitation Limit (PQL)

Blank = Not sampled

WELL NUMBER 89-02(3)  
ANALYTICAL SAMPLING RESULTS  
(Concentrations in ug/L)

ANALYTE	7/17/96	11/5/96	1/15/97	4/29/97	7/22/97	10/30/97	4/20/98	10/28/98	AVG
CHLOROMETHANE	5 U	0.5 U	0.5 U	0.5 U	0.5 U	0.5 U	1 U	1 U	0.0
VINYL CHLORIDE	5 U	0.5 U	0.5 U	0.5 U	0.5 U	0.5 U	1 U	1 U	0.0
CHLOROETHANE	5 U	0.5 U	0.5 U	0.5 U	0.5 U	0.5 U	1 U	1 U	0.0
BROMOMETHANE	5 U	0.5 U	0.5 U	0.5 U	0.5 U	0.5 U	1 U	1 U	0.0
1 1-DICHLOROETHENE	5 U	0.5 U	0.5 U	0.5 U	0.5 U	0.5 U	1 U	1 U	0.0
ACETONE	25 U	10 U	10 U	10 U	10 U	10 U	10 U	10 U	2.1
CARBON DISULFIDE	1	0.5 U	0.5 U	1	1	0.7	4	2	1.6
METHYLENE CHLORIDE	5 U	0.5 U	0.5 U	0.5 U	0.5 U	0.5 U	2 U	1 U	0.0
TRANS-1 2-DICHLOROETHENE	5 U	0.5 U	0.5 U	0.5 U	0.5 U	0.5 U	1 U	1 U	0.0
1 1-DICHLOROETHANE	5 U	0.5 U	0.5 U	0.5 U	0.5 U	0.5 U	1 U	1 U	0.0
CIS-1 2-DICHLOROETHENE	5 U	0.5 U	0.5 U	0.5 U	0.5 U	0.6	1 U	1 U	0.0
METHYL ETHYL KETONE	25 U	11	10 U	10 U	10 U	10 U	10 U	10 U	0.6
CHLOROFORM	5 U	0.5 U	0.5 U	0.5 U	0.5 U	0.5 U	1 U	1 U	0.0
1 1 1-TRICHLOROETHANE	5 U	0.5 U	0.5 U	0.5 U	0.5 U	0.5 U	1 U	1 U	0.0
CARBON TETRACHLORIDE	5 U	0.5 U	0.5 U	0.5 U	0.5 U	0.5 U	1 U	1 U	0.0
BENZENE	5 U	0.5 U	0.5 U	0.5 U	0.5 U	0.5 U	0.7 U	0.700 U	0.0
1 2-DICHLOROETHANE	5 U	0.5 U	0.5 U	0.5 U	0.5 U	0.5 U	1 U	1 U	0.0
TRICHLOROETHENE	5 U	0.5 U	0.5 U	0.8	0.5 U	0.5 U	1 U	1 U	0.0
1 2-DICHLOROPROPANE	5 U	0.5 U	0.5 U	0.5 U	0.5 U	0.5 U	1 U	1 U	0.0
BROMODICHLOROMETHANE	5 U	0.5 U	0.5 U	0.5 U	0.5 U	0.5 U	1 U	1 U	0.0
CIS-1 3-DICHLOROPROPENE	5 U	0.5 U	0.5 U	0.5 U	0.5 U	0.5 U	1 U	1 U	0.0
MIBK	10 U	10 U	10 U	10 U	10 U	10 U	10 U	10 U	0.0
TOLUENE	5 U	0.5 U	0.5 U	0.5 U	0.5 U	0.5 U	1 U	1 U	0.0
TRANS-1 3-DICHLOROPROPENE	5 U	0.5 U	0.5 U	0.5 U	0.5 U	0.5 U	1 U	1 U	0.0
1 1 2-TRICHLOROETHANE	5 U	0.5 U	0.5 U	0.5 U	0.5 U	0.5 U	1 U	1 U	0.0
TETRACHLOROETHENE	5 U	0.5 U	0.5 U	0.5 U	0.5 U	0.5 U	1 U	1 U	0.0
2-HEXANONE	10 U	10 U	10 U	10 U	10 U	10 U	10 U	10 U	0.0
DIBROMOCHLOROMETHANE	5 U	0.5 U	0.5 U	0.5 U	0.5 U	0.5 U	1 U	1 U	0.0
CHLOROBENZENE	5 U	0.5 U	0.5 U	0.5 U	0.5 U	0.5 U	1 U	1 U	0.0
ETHYLBENZENE	5 U	0.5 U	0.5 U	0.5 U	0.5 U	0.5 U	1 U	1 U	0.0
P-XYLENE/M-XYLENE	5 U	0.5 U	0.5 U	0.5 U	0.5 U	0.5 U	1 U	1 U	0.0
O-XYLENE	5 U	0.5 U	0.5 U	0.5 U	0.5 U	0.5 U	1 U	1 U	0.0
STYRENE	5 U	0.5 U	0.5 U	0.5 U	0.5 U	0.5 U	1 U	1 U	0.0
BROMOFORM	5 U	0.5 U	0.5 U	0.5 U	0.5 U	0.5 U	1 U	1 U	0.0
1 1 2 2-TETRACHLOROETHANE	5 U	0.5 U	0.5 U	0.5 U	0.5 U	0.5 U	1 U	1 U	0.0

**NOTES:**

U = Below Practical Quantitation Limit (PQL)

Blank = Not sampled

WELL NUMBER 89-03(1)  
ANALYTICAL SAMPLING RESULTS  
(Concentrations in ug/L)

ANALYTE	4/93	7/93	10/93	1/18/94	4/94	7/94	10/94	1/9/95	4/95	7/95	10/95	1/30/96	4/96	7/96	10/15/96
CHLOROMETHANE				0.5 U				0.5 U				0.5 U			0.5 U
VINYL CHLORIDE				0.5 U				0.5 U				0.5 U			0.5 U
CHLOROETHANE				0.5 U				0.5 U				0.5 U			0.5 U
BROMOMETHANE				0.5 U				0.5 U				0.5 U			0.5 U
1 1-DICHLOROETHENE				0.5 U				0.5 U				0.5 U			0.5 U
ACETONE				50 U				10 U				12			10 U
CARBON DISULFIDE				0.5 U				0.5 U				0.5 U			0.5 U
METHYLENE CHLORIDE				0.5 U				0.5 U				0.5 U			0.5 U
TRANS-1 2-DICHLOROETHENE				0.5 U				0.5 U				0.5 U			0.5 U
1 1-DICHLOROETHANE				0.5 U				0.5 U				0.5 U			0.5 U
CIS-1 2-DICHLOROETHENE				9				31				25			39
METHYL ETHYL KETONE				50 U				10 U				10 U			10 U
CHLOROFORM				0.5 U				0.5 U				0.5 U			0.5 U
1 1 1-TRICHLOROETHANE				0.5 U				0.5 U				0.5 U			0.5 U
CARBON TETRACHLORIDE				0.5 U				0.5 U				0.5 U			0.5 U
BENZENE				0.5 U				0.5 U				0.5 U			0.5 U
1 2-DICHLOROETHANE				0.5 U				0.5 U				0.5 U			0.5 U
TRICHLOROETHENE				0.5 U				0.6				0.5 U			0.5 U
1 2-DICHLOROPROPANE				0.5 U				0.5 U				0.5 U			0.5 U
BROMODICHLOROMETHANE				0.5 U				0.5 U				0.5 U			0.5 U
CIS-1 3-DICHLOROPROPENE				0.5 U				0.5 U				0.5 U			0.5 U
MIBK				50 U				10 U				10 U			10 U
TOLUENE				0.5 U				0.5 U				0.5 U			0.5 U
TRANS-1 3-DICHLOROPROPENE				0.5 U				0.5 U				0.5 U			0.5 U
1 1 2-TRICHLOROETHANE				0.5 U				0.5 U				0.5 U			0.5 U
TETRACHLOROETHENE				0.5 U				0.5 U				0.5 U			0.5 U
2-HEXANONE				50 U				10 U				10 U			10 U
DIBROMOCHLOROMETHANE				0.5 U				0.5 U				0.5 U			0.5 U
CHLOROBENZENE				0.5 U				0.5 U				0.5 U			0.5 U
ETHYLBENZENE				0.5 U				0.5 U				0.5 U			0.5 U
P-XYLENE/M-XYLENE				0.5 U				0.5 U				0.5 U			0.5 U
O-XYLENE				0.5 U				0.5 U				0.5 U			0.5 U
STYRENE				0.5 U				0.5 U				0.5 U			0.5 U
BROMOFORM				0.5 U				0.5 U				0.5 U			0.5 U
1 1 2 2-TETRACHLOROETHANE				0.5 U				0.5 U				1 U			0.5 U

## NOTES:

U = Below Practical Quantitation Limit (PQL)

Blank = Not sampled

WELL NUMBER 89-03(1)  
ANALYTICAL SAMPLING RESULTS  
(Concentrations in ug/L)

ANALYTE	1/97	4/97	7/97	10/97	4/22/98	10/27/98	AVG
CHLOROMETHANE					1 U	1 U	0.0
VINYL CHLORIDE					1 U	1 U	0.0
CHLOROETHANE					1 U	1 U	0.0
BROMOMETHANE					1 U	1 U	0.0
1 1-DICHLOROETHENE					1 U	1 U	0.0
ACETONE					10 U	10 U	2.0
CARBON DISULFIDE					1 U	1 U	0.0
METHYLENE CHLORIDE					2 U	1 U	0.0
TRANS-1 2-DICHLOROETHENE					1 U	1 U	0.0
1 1-DICHLOROETHANE					1 U	1 U	0.0
CIS-1 2-DICHLOROETHENE					11	64	29.8
METHYL ETHYL KETONE					10 U	10 U	0.0
CHLOROFORM					1 U	1 U	0.0
1 1 1-TRICHLOROETHANE					1 U	1 U	0.0
CARBON TETRACHLORIDE					1 U	1 U	0.0
BENZENE					0.7 U	0.700 U	0.0
1 2-DICHLOROETHANE					1 U	1 U	0.0
TRICHLOROETHENE					1 U	1 U	0.1
1 2-DICHLOROPROPANE					1 U	1 U	0.0
BROMODICHLOROMETHANE					1 U	1 U	0.0
CIS-1 3-DICHLOROPROPENE					1 U	1 U	0.0
MIBK					10 U	10 U	0.0
TOLUENE					1 U	1 U	0.0
TRANS-1 3-DICHLOROPROPENE					1 U	1 U	0.0
1 1 2-TRICHLOROETHANE					1 U	1 U	0.0
TETRACHLOROETHENE					1 U	1 U	0.0
2-HEXANONE					10 U	10 U	0.0
DIBROMOCHLOROMETHANE					1 U	1 U	0.0
CHLOROBENZENE					1 U	1 U	0.0
ETHYLBENZENE					1 U	1 U	0.0
P-XYLENE/M-XYLENE					1 U	1 U	0.0
O-XYLENE					1 U	1 U	0.0
STYRENE					1 B	1 U	0.0
BROMOFORM					1 U	1 U	0.0
1 1 2 2-TETRACHLOROETHANE					1 U	1 U	0.0

## NOTES:

U = Below Practical Quantitation Limit (PQL)

Blank = Not sampled



WELL NUMBER 89-04(1)  
 ANALYTICAL SAMPLING RESULTS  
 (Concentrations in ug/L)

ANALYTE	4/20/93	7/20/93	10/13/93	1/18/94	4/94	7/20/94	10/94	1/10/95	4/95	7/11/95	10/95	1/30/96	4/19/96	7/96
CHLOROMETHANE	5 U	5 U	5 U	5 U		5 U		5 U		5 U		5 U	5 U	
VINYL CHLORIDE	49	36	33	12		24		5 U		5 U		5 U	5 U	
CHLOROETHANE	5 U	5 U	5 U	5 U		5 U		5 U		5 U		5 U	5 U	
BROMOMETHANE	5 U	5 U	5 U	5 U		5 U		5 U		5 U		5 U	5 U	
1 1-DICHLOROETHENE	19	10	6	5 U		7		5 U		6		5 U	5 U	
ACETONE	50 U	50 U	50 U	50 U		50 U		50 U		50 U		25 U	25 U	
CARBON DISULFIDE	98	80	88	73		74		67		94		5 U	42	
METHYLENE CHLORIDE	5 U	5 U	5 U	5 U		5 U		5 U		5 U		5 U	5 U	
TRANS-1 2-DICHLOROETHENE	5 U	5 U	5 U	6		5 U		5 U		5 U		5 U	5 U	
1 1-DICHLOROETHANE	5 U	5 U	5 U	5 U		5 U		5 U		5 U		5 U	5 U	
CIS-1 2-DICHLOROETHENE	96	76	71	40		60		37		39		5 U	18	
METHYL ETHYL KETONE	50 U	50 U	50 U	50 U		50 U		50 U		50 U		25 U	25 U	
CHLOROFORM	5 U	5 U	5 U	5 U		5 U		5 U		5 U		5 U	5 U	
1 1 1-TRICHLOROETHANE	5 U	5 U	5 U	5 U		5 U		5 U		5 U		5 U	5 U	
CARBON TETRACHLORIDE	5 U	5 U	5 U	5 U		5 U		5 U		5 U		5 U	5 U	
BENZENE	6	5 U	5 U	5 U		5 U		5 U		5 U		5 U	5 U	
1 2-DICHLOROETHANE	5 U	5 U	5 U	5 U		5 U		5 U		5 U		5 U	5 U	
TRICHLOROETHENE	12	8	8	7		6		5 U		6		5 U	5 U	
1 2-DICHLOROPROPANE	5 U	5 U	5 U	5 U		5 U		5 U		5 U		5 U	5 U	
BROMODICHLOROMETHANE	5 U	5 U	5 U	5 U		5 U		5 U		5 U		5 U	5 U	
CIS-1 3-DICHLOROPROPENE	5 U	5 U	5 U	5 U		5 U		5 U		5 U		5 U	5 U	
MIBK	50 U	50 U	50 U	50 U		50 U		50 U		50 U		25 U	10 U	
TOLUENE	6	5 U	5 U	5 U		5 U		5 U		5 U		5 U	5 U	
TRANS-1 3-DICHLOROPROPENE	5 U	5 U	5 U	5 U		5 U		5 U		5 U		5 U	5 U	
1 1 2-TRICHLOROETHANE	5 U	5 U	5 U	5 U		5 U		5 U		5 U		5 U	5 U	
TETRACHLOROETHENE	5 U	5 U	5 U	5 U		5 U		5 U		5 U		5 U	5 U	
2-HEXANONE	50 U	50 U	50 U	50 U		50 U		50 U		50 U		25 U	10 U	
DIBROMOCHLOROMETHANE	5 U	5 U	5 U	5 U		5 U		5 U		5 U		5 U	5 U	
CHLORO BENZENE	5 U	5 U	5 U	5 U		5 U		5 U		5 U		5 U	5 U	
ETHYLBENZENE	5 U	5 U	5 U	5 U		5 U		5 U		5 U		5 U	5 U	
P-XYLENE/M-XYLENE	5 U	5 U	5 U	5 U		5 U		5 U		5 U		5 U	5 U	
O-XYLENE	5 U	5 U	5 U	5 U		5 U		5 U		5 U		5 U	5 U	
STYRENE	5 U	5 U	5 U	5 U		5 U		5 U		5 U		5 U	5 U	
BROMOFORM	5 U	5 U	5 U	5 U		5 U		5 U		5 U		5 U	5 U	
1 1 2 2-TETRACHLOROETHANE	5 U	5 U	5 U	5 U		5 U		5 U		5 U		5 U	5 U	

NOTES:

U = Below Practical Quantitation Limit (PQL)

Blank = Not sampled

WELL NUMBER 89-04(1)  
ANALYTICAL SAMPLING RESULTS  
(Concentrations in ug/L)

ANALYTE	10/15/96	1/97	4/29/97	7/97	10/28/97	4/20/98	10/27/98	AVG
CHLOROMETHANE	5 U		0.5 U		5 U	1 U	1 U	0.0
VINYL CHLORIDE	5 U		2		5 U	1 U	4	11.4
CHLOROETHANE	5 U		0.5 U		5 U	1 U	1 U	0.0
BROMOMETHANE	5 U		0.5 U		5 U	1 U	1 U	0.0
1 1-DICHLOROETHENE	5 U		4		5 U	3	3	4.1
ACETONE	25 U		10 U		25 U	10 U	10 U	0.0
CARBON DISULFIDE	150		86		110	110	99	83.6
METHYLENE CHLORIDE	5 U		0.5 U		5 U	2 U	1 U	0.0
TRANS-1 2-DICHLOROETHENE	5 U		2		5 U	1 U	1 U	0.6
1 1-DICHLOROETHANE	5 U		0.5 U		5 U	1 U	1 U	0.0
CIS-1 2-DICHLOROETHENE	22		23		22	18	19	38.6
METHYL ETHYL KETONE	25 U		10 U		25 U	10 U	10 U	0.0
CHLOROFORM	5 U		0.5 U		5 U	1 U	1 U	0.0
1 1 1-TRICHLOROETHANE	5 U		0.5 U		5 U	1 U	1 U	0.0
CARBON TETRACHLORIDE	5 U		0.5 U		5 U	1 U	1 U	0.0
BENZENE	5 U		0.5 U		5 U	0.7 U	0.700 U	0.4
1 2-DICHLOROETHANE	5 U		0.5 U		5 U	1 U	1 U	0.0
TRICHLOROETHENE	6		6		7	6	6	5.6
1 2-DICHLOROPROPANE	5 U		0.5 U		5 U	1 U	1 U	0.0
BROMODICHLOROMETHANE	5 U		0.5 U		5 U	1 U	1 U	0.0
CIS-1 3-DICHLOROPROPENE	5 U		0.5 U		5 U	1 U	1 U	0.0
MIBK	10 U		10 U		10 U	10 U	10 U	0.0
TOLUENE	5 U		0.5 U		5 U	1 U	1 U	0.4
TRANS-1 3-DICHLOROPROPENE	5 U		0.5 U		5 U	1 U	1 U	0.0
1 1 2-TRICHLOROETHANE	5 U		0.5 U		5 U	1 U	1 U	0.0
TETRACHLOROETHENE	5 U		0.5 U		5 U	1 U	1 U	0.0
2-HEXANONE	10 U		10 U		10 U	10 U	10 U	0.0
DIBROMOCHLOROMETHANE	5 U		0.5 U		5 U	1 U	1 U	0.0
CHLOROBENZENE	5 U		0.5 U		5 U	1 U	1 U	0.0
ETHYLBENZENE	5 U		0.5 U		5 U	1 U	1 U	0.0
P-XYLENE/M-XYLENE	5 U		0.5 U		5 U	1 U	1 U	0.0
O-XYLENE	5 U		0.5 U		5 U	1 U	1 U	0.0
STYRENE	5 U		0.5 U		5 U	1 U	1 U	0.0
BROMOFORM	5 U		0.5 U		5 U	1 U	1 U	0.0
1 1 2 2-TETRACHLOROETHANE	5 U		1 U		5 U	1 U	1 U	0.0

**NOTES:**

U = Below Practical Quantitation Limit (PQL)

Blank = Not sampled

WELL NUMBER 89-05(1A)  
ANALYTICAL SAMPLING RESULTS  
(Concentrations in ug/L)

ANALYTE	4/20/93	7/21/93	10/13/93	1/21/94	4/94	7/19/94	10/94	1/10/95	4/95	7/13/95	10/95	1/29/96	4/19/96	7/96
CHLOROMETHANE	5 U	5 U	5 U	5 U		25 U		5 U		5 U		25 U	25 U	
VINYL CHLORIDE	29	14	73	46		61		61		94		110	92	
CHLOROETHANE	5 U	5 U	5 U	5 U		25 U		5 U		5 U		25 U	25 U	
BROMOMETHANE	5 U	5 U	5 U	5 U		25 U		5 U		5 U		25 U	25 U	
1 1-DICHLOROETHENE	5 U	5 U	5 U	6		25 U		5 U		5 U		25 U	25 U	
ACETONE	192	50 U	50 U	50 U		250 U		50 U		50 U		125 U	125 U	
CARBON DISULFIDE	5 U	5 U	5 U	5 U		25 U		5 U		5 U		25 U	25 U	
METHYLENE CHLORIDE	5 U	5 U	5 U	5		25 U		5 U		5 U		25 U	25 U	
TRANS-1 2-DICHLOROETHENE	5 U	5 U	7	5 U		25 U		5 U		5 U		25 U	25 U	
1 1-DICHLOROETHANE	5 U	5 U	5 U	10		25 U		5 U		5 U		25 U	25 U	
CIS-1 2-DICHLOROETHENE	174	38	1440 J	1990		708		95		397		860	880	
METHYL ETHYL KETONE	50 U	50 U	50 U	50 U		250 U		50 U		50 U		125 U	125 U	
CHLOROFORM	5 U	5 U	5 U	5 U		25 U		5 U		5 U		25 U	25 U	
1 1 1-TRICHLOROETHANE	5 U	5 U	15	22		25 U		5 U		5 U		25 U	25 U	
CARBON TETRACHLORIDE	5 U	5 U	5 U	5 U		25 U		5 U		5 U		25 U	25 U	
BENZENE	8	5 U	5 U	5 U		25 U		5 U		5 U		25 U	25 U	
1 2-DICHLOROETHANE	5 U	5 U	5 U	5 U		25 U		5 U		5 U		25 U	25 U	
TRICHLOROETHENE	5 U	5 U	61	112		25 U		5 U		6		25 U	25 U	
1 2-DICHLOROPROPANE	5 U	5 U	5 U	5 U		25 U		5 U		5 U		25 U	25 U	
BROMODICHLOROMETHANE	5 U	5 U	5 U	5 U		25 U		5 U		5 U		25 U	25 U	
CIS-1 3-DICHLOROPROPENE	5 U	5 U	5 U	5 U		25 U		5 U		5 U		25 U	25 U	
MIBK	50 U	50 U	50 U	50 U		250 U		50 U		50 U		125 U	50 U	
TOLUENE	8	5 U	5 U	5 U		25 U		5 U		5 U		25 U	25 U	
TRANS-1 3-DICHLOROPROPENE	5 U	5 U	5 U	5 U		25 U		5 U		5 U		25 U	25 U	
1 1 2-TRICHLOROETHANE	5 U	5 U	5 U	5 U		25 U		5 U		5 U		25 U	25 U	
TETRACHLOROETHENE	5 U	5 U	5 U	5 U		25 U		5 U		5 U		25 U	25 U	
2-HEXANONE	50 U	50 U	50 U	50 U		250 U		50 U		50 U		125 U	50 U	
DIBROMOCHLOROMETHANE	5 U	5 U	5 U	5 U		25 U		5 U		5 U		25 U	25 U	
CHLOROBENZENE	5 U	5 U	5 U	5 U		25 U		5 U		5 U		25 U	25 U	
ETHYLBENZENE	5 U	5 U	5 U	5 U		25 U		5 U		5 U		25 U	25 U	
P-XYLENE/M-XYLENE	5 U	5 U	5 U	5 U		25 U		5 U		5 U		25 U	25 U	
O-XYLENE	5 U	5 U	5 U	5 U		25 U		5 U		5 U		25 U	25 U	
STYRENE	5 U	5 U	5 U	5 U		25 U		5 U		5 U		25 U	25 U	
BROMOFORM	5 U	5 U	5 U	5 U		25 U		5 U		5 U		25 U	25 U	
1 1 2 2-TETRACHLOROETHANE	5 U	5 U	5 U	5 U		25 U		5 U		5 U		25 U	25 U	

**NOTES:**

U = Below Practical Quantitation Limit (PQL)

J = Estimated

Blank = Not sampled

WELL NUMBER 89-05(1A)  
ANALYTICAL SAMPLING RESULTS  
(Concentrations in ug/L)

ANALYTE	10/17/96	1/97	4/29/97	7/97	10/29/97	4/20/98	AVG
CHLOROMETHANE	25 U		25 U		25 U	1 U	0.0
VINYL CHLORIDE	32		36		34	48	56.2
CHLOROETHANE	25 U		25 U		25 U	1 U	0.0
BROMOMETHANE	25 U		25 U		25 U	1 U	0.0
1 1-DICHLOROETHENE	25 U		25 U		25 U	2	0.6
ACETONE	120 U		120 U		120 U	10 U	14.8
CARBON DISULFIDE	25 U		25 U		25 U	3	0.2
METHYLENE CHLORIDE	25 U		25 U		25 U	2 U	0.4
TRANS-1 2-DICHLOROETHENE	25 U		25 U		25 U	1	0.6
1 1-DICHLOROETHANE	25 U		25 U		25 U	1 U	0.8
CIS-1 2-DICHLOROETHENE	320		300		190	190	472.5
METHYL ETHYL KETONE	120 U		120 U		120 U	10 U	0.0
CHLOROFORM	25 U		25 U		25 U	1 U	0.0
1 1 1-TRICHLOROETHANE	25 U		25 U		25 U	2	3.0
CARBON TETRACHLORIDE	25 U		25 U		25 U	1 U	0.0
BENZENE	25 U		25 U		25 U	0.7 U	0.6
1 2-DICHLOROETHANE	25 U		25 U		25 U	1 U	0.0
TRICHLOROETHENE	25 U		25 U		25 U	4	14.1
1 2-DICHLOROPROPANE	25 U		25 U		25 U	1 U	0.0
BROMODICHLOROMETHANE	25 U		25 U		25 U	1 U	0.0
CIS-1 3-DICHLOROPROPENE	25 U		25 U		25 U	1 U	0.0
MIBK	50 U		50 U		50 U	10 U	0.0
TOLUENE	25 U		25 U		25 U	1 U	0.6
TRANS-1 3-DICHLOROPROPENE	25 U		25 U		25 U	1 U	0.0
1 1 2-TRICHLOROETHANE	25 U		25 U		25 U	1 U	0.0
TETRACHLOROETHENE	25 U		25 U		25 U	1 U	0.0
2-HEXANONE	50 U		50 U		50 U	10 U	0.0
DIBROMOCHLOROMETHANE	25 U		25 U		25 U	1 U	0.0
CHLOROBENZENE	25 U		25 U		25 U	1 U	0.0
ETHYLBENZENE	25 U		25 U		25 U	1 U	0.0
P-XYLENE/M-XYLENE	25 U		25 U		25 U	1 U	0.0
O-XYLENE	25 U		25 U		25 U	1 U	0.0
STYRENE	25 U		25 U		25 U	1 U	0.0
BROMOFORM	25 U		25 U		25 U	1 U	0.0
1 1 2 2-TETRACHLOROETHANE	25 U		25 U		25 U	1 U	0.0

**NOTES:**

U = Below Practical Quantitation Limit (PQL)

J = Estimated

Blank = Not sampled

WELL NUMBER 89-05(1B)  
ANALYTICAL SAMPLING RESULTS  
(Concentrations in ug/L)

ANALYTE	4/20/93	7/21/93	10/13/93	1/21/94	4/94	7/94	10/94	1/10/95	4/95	7/95	10/95	1/29/96	4/96	7/96
CHLOROMETHANE	5 U	5 U	5 U	5 U				5 U				50 U		
VINYL CHLORIDE	17	9	31	30				58				62		
CHLOROETHANE	5 U	5 U	5 U	5 U				5 U				50 U		
BROMOMETHANE	5 U	5 U	5 U	5 U				5 U				50 U		
1 1-DICHLOROETHENE	5 U	5 U	5 U	5 U				5 U				50 U		
ACETONE	50 U	50 U	50 U	50 U				50 U				250 U		
CARBON DISULFIDE	5 U	5 U	5 U	5 U				5 U				50 U		
METHYLENE CHLORIDE	5 U	5 U	5 U	5 U				5 U				50 U		
TRANS-1 2-DICHLOROETHENE	5 U	5 U	5 U	5 U				5 U				50 U		
1 1-DICHLOROETHANE	5 U	5 U	5 U	5 U				5 U				50 U		
CIS-1 2-DICHLOROETHENE	115	42	254	178				835				380		
METHYL ETHYL KETONE	50 U	50 U	50 U	50 U				50 U				250 U		
CHLOROFORM	5 U	5 U	5 U	5 U				5 U				50 U		
1 1 1-TRICHLOROETHANE	5 U	5 U	5 U	5 U				5				50 U		
CARBON TETRACHLORIDE	5 U	5 U	5 U	5 U				5 U				50 U		
BENZENE	5 U	5 U	5 U	5 U				5 U				50 U		
1 2-DICHLOROETHANE	5 U	5 U	5 U	5 U				5 U				50 U		
TRICHLOROETHENE	5 U	5 U	5 U	5 U				6				50 U		
1 2-DICHLOROPROPANE	5 U	5 U	5 U	5 U				5 U				50 U		
BROMODICHLOROMETHANE	5 U	5 U	5 U	5 U				5 U				50 U		
CIS-1 3-DICHLOROPROPENE	5 U	5 U	5 U	5 U				5 U				50 U		
MIBK	50 U	50 U	50 U	50 U				50 U				250 U		
TOLUENE	5 U	5 U	5 U	5 U				5 U				50 U		
TRANS-1 3-DICHLOROPROPENE	5 U	5 U	5 U	5 U				5 U				50 U		
1 1 2-TRICHLOROETHANE	5 U	5 U	5 U	5 U				5 U				50 U		
TETRACHLOROETHENE	5 U	5 U	5 U	5 U				5 U				50 U		
2-HEXANONE	50 U	50 U	50 U	50 U				50 U				250 U		
DIBROMOCHLOROMETHANE	5 U	5 U	5 U	5 U				5 U				50 U		
CHLOROBENZENE	5 U	5 U	5 U	5 U				5 U				50 U		
ETHYLBENZENE	5 U	5 U	5 U	5 U				5 U				50 U		
P-XYLENE/M-XYLENE	5 U	5 U	5 U	5 U				5 U				50 U		
O-XYLENE	5 U	5 U	5 U	5 U				5 U				50 U		
STYRENE	5 U	5 U	5 U	5 U				5 U				50 U		
BROMOFORM	5 U	5 U	5 U	5 U				5 U				50 U		
1 1 2 2-TETRACHLOROETHANE	5 U	5 U	5 U	5 U				5 U				50 U		

**NOTES:**

U = Below Practical Quantitation Limit (PQL)

Blank = Not sampled

WELL NUMBER 89-05(1B)  
ANALYTICAL SAMPLING RESULTS  
(Concentrations in ug/L)

ANALYTE	10/17/96	1/97	4/97	7/97	10/29/97	4/98	AVG
CHLOROMETHANE	5 U				0.5 U		0.0
VINYL CHLORIDE	9				22		29.8
CHLOROETHANE	5 U				0.5 U		0.0
BROMOMETHANE	5 U				0.5 U		0.0
1 1-DICHLOROETHENE	5 U				0.5 U		0.0
ACETONE	25 U				10 U		0.0
CARBON DISULFIDE	5 U				0.5 U		0.0
METHYLENE CHLORIDE	5 U				0.5 U		0.0
TRANS-1 2-DICHLOROETHENE	5 U				0.5 U		0.0
1 1-DICHLOROETHANE	5 U				0.5 U		0.0
CIS-1 2-DICHLOROETHENE	32				41		234.6
METHYL ETHYL KETONE	25 U				10 U		0.0
CHLOROFORM	5 U				0.5 U		0.0
1 1 1-TRICHLOROETHANE	5 U				0.5 U		0.6
CARBON TETRACHLORIDE	5 U				0.5 U		0.0
BENZENE	5 U				0.5 U		0.0
1 2-DICHLOROETHANE	5 U				0.5 U		0.0
TRICHLOROETHENE	5 U				0.5 U		0.8
1 2-DICHLOROPROPANE	5 U				0.5 U		0.0
BROMODICHLOROMETHANE	5 U				0.5 U		0.0
CIS-1 3-DICHLOROPROPENE	5 U				0.5 U		0.0
MIBK	10 U				10 U		0.0
TOLUENE	5 U				0.5 U		0.0
TRANS-1 3-DICHLOROPROPENE	5 U				0.5 U		0.0
1 1 2-TRICHLOROETHANE	5 U				0.5 U		0.0
TETRACHLOROETHENE	5 U				0.5 U		0.0
2-HEXANONE	10 U				10 U		0.0
DIBROMOCHLOROMETHANE	5 U				0.5 U		0.0
CHLOROBENZENE	5 U				0.5 U		0.0
ETHYLBENZENE	5 U				0.5 U		0.0
P-XYLENE/M-XYLENE	5 U				0.5 U		0.0
O-XYLENE	5 U				0.5 U		0.0
STYRENE	5 U				0.5 U		0.0
BROMOFORM	5 U				0.5 U		0.0
1 1 2 2-TETRACHLOROETHANE	5 U				0.5 U		0.0

**NOTES:**

U = Below Practical Quantitation Limit (PQL)

Blank = Not sampled

WELL NUMBER 89-06(1)  
 ABALYTICAL SAMPLING RESULTS  
 (Concentrations in ug/L)

ANALYTE	4/93	7/93	10/93	1/20/94	4/94	7/94	10/94	1/9/95	4/95	7/95	10/95	1/30/96	4/96	7/96	10/15/96
CHLOROMETHANE				0.5 U				0.5 U				0.5 U			0.5 U
VINYL CHLORIDE				0.5 U				0.5 U				0.5 U			0.5 U
CHLOROETHANE				0.5 U				0.5 U				0.5 U			0.5 U
BROMOMETHANE				0.5 U				0.5 U				0.5 U			0.5 U
1 1-DICHLOROETHENE				0.5 U				0.5 U				0.5 U			0.5 U
ACETONE				50 U				10 U				10			10 U
CARBON DISULFIDE				0.5 U				0.8				0.5 U			0.5 U
METHYLENE CHLORIDE				0.5 U				0.5 U				0.5 U			0.5 U
TRANS-1 2-DICHLOROETHENE				0.5 U				0.5 U				0.5 U			0.5 U
1 1-DICHLOROETHANE				0.5 U				0.5 U				0.5 U			0.5 U
CIS-1 2-DICHLOROETHENE				0.5 U				0.5 U				0.5 U			0.5 U
METHYL ETHYL KETONE				50 U				10 U				10 U			10 U
CHLOROFORM				0.5 U				0.5 U				0.5 U			0.5 U
1 1 1-TRICHLOROETHANE				0.5 U				0.5 U				0.5 U			0.5 U
CARBON TETRACHLORIDE				0.5 U				0.5 U				0.5 U			0.5 U
BENZENE				0.5 U				0.5 U				0.5 U			0.5 U
1 2-DICHLOROETHANE				0.5 U				0.5 U				0.5 U			0.5 U
TRICHLOROETHENE				0.5 U				0.5 U				0.5 U			0.5 U
1 2-DICHLOROPROPANE				0.5 U				0.5 U				0.5 U			0.5 U
BROMODICHLOROMETHANE				0.5 U				0.5 U				0.5 U			0.5 U
CIS-1 3-DICHLOROPROPENE				0.5 U				0.5 U				0.5 U			0.5 U
MIBK				50 U				10 U				10 U			10 U
TOLUENE				0.5 U				0.5 U				0.5 U			0.5 U
TRANS-1 3-DICHLOROPROPENE				0.5 U				0.5 U				0.5 U			0.5 U
1 1 2-TRICHLOROETHANE				0.5 U				0.5 U				0.5 U			0.5 U
TETRACHLOROETHENE				0.5 U				0.5 U				0.5 U			0.5 U
2-HEXANONE				50 U				10 U				10 U			10 U
DIBROMOCHLOROMETHANE				0.5 U				0.5 U				0.5 U			0.5 U
CHLOROBENZENE				0.5 U				0.5 U				0.5 U			0.5 U
ETHYLBENZENE				0.5 U				0.5 U				0.5 U			0.5 U
P-XYLENE/M-XYLENE				0.5 U				0.5 U				0.5 U			0.5 U
O-XYLENE				0.5 U				0.5 U				0.5 U			0.5 U
STYRENE				0.5 U				0.5 U				0.5 U			0.5 U
BROMOFORM				0.5 U				0.5 U				0.5 U			0.5 U
1 1 2 2-TETRACHLOROETHANE				0.5 U				0.5 U				1 U			0.5 U

**NOTES:**

U = Below Practical Quantitation Limit (PQL)

Blank = Not sampled

WELL NUMBER 89-06(1)  
 ABALYTICAL SAMPLING RESULTS  
 (Concentrations in ug/L)

ANALYTE	1/97	4/97	7/97	10/28/97	4/98	AVG
CHLOROMETHANE				0.5 U		0.0
VINYL CHLORIDE				0.5 U		0.0
CHLOROETHANE				0.5 U		0.0
BROMOMETHANE				0.5 U		0.0
1 1-DICHLOROETHENE				0.5 U		0.0
ACETONE				10 U		2.0
CARBON DISULFIDE				0.5 U		0.2
METHYLENE CHLORIDE				0.5 U		0.0
TRANS-1 2-DICHLOROETHENE				0.5 U		0.0
1 1-DICHLOROETHANE				0.5 U		0.0
CIS-1 2-DICHLOROETHENE				0.5 U		0.0
METHYL ETHYL KETONE				10 U		0.0
CHLOROFORM				0.5 U		0.0
1 1 1-TRICHLOROETHANE				0.5 U		0.0
CARBON TETRACHLORIDE				0.5 U		0.0
BENZENE				0.5 U		0.0
1 2-DICHLOROETHANE				0.5 U		0.0
TRICHLOROETHENE				0.5 U		0.0
1 2-DICHLOROPROPANE				0.5 U		0.0
BROMODICHLOROMETHANE				0.5 U		0.0
CIS-1 3-DICHLOROPROPENE				0.5 U		0.0
MIBK				10 U		0.0
TOLUENE				0.5 U		0.0
TRANS-1 3-DICHLOROPROPENE				0.5 U		0.0
1 1 2-TRICHLOROETHANE				0.5 U		0.0
TETRACHLOROETHENE				0.5 U		0.0
2-HEXANONE				10 U		0.0
DIBROMOCHLOROMETHANE				0.5 U		0.0
CHLOROBENZENE				0.5 U		0.0
ETHYLBENZENE				0.5 U		0.0
P-XYLENE/M-XYLENE				0.5 U		0.0
O-XYLENE				0.5 U		0.0
STYRENE				0.5 U		0.0
BROMOFORM				0.5 U		0.0
1 1 2 2-TETRACHLOROETHANE				0.5 U		0.0

**NOTES:**

U = Below Practical Quantitation Limit (PQL)

Blank = Not sampled



WELL NUMBER 89-07(1A)  
 ANALYTICAL SAMPLING RESULTS  
 (concentrations in ug/L)

ANALYTE	4/93	7/93	10/93	1/24/94	4/94	7/94	10/94	1/11/95	4/95	7/95	10/95	1/96	4/96	7/96	10/17/96
CHLOROMETHANE				0.5 U				0.5 U							0.6
VINYL CHLORIDE				0.5 U				0.5 U							0.5 U
CHLOROETHANE				0.5 U				0.5 U							0.5 U
BROMOMETHANE				0.5 U				0.5 U							0.5 U
1 1-DICHLOROETHENE				0.5 U				0.5 U							0.5 U
ACETONE				50 U				10 U							10 U
CARBON DISULFIDE				0.5 U				0.5 U							0.8
METHYLENE CHLORIDE				0.5 U				0.5 U							0.5 U
TRANS-1 2-DICHLOROETHENE				0.5 U				0.5 U							0.5 U
1 1-DICHLOROETHANE				0.5 U				0.5 U							0.5 U
CIS-1 2-DICHLOROETHENE				0.5 U				0.5 U							0.5 U
METHYL ETHYL KETONE				50 U				10 U							10 U
CHLOROFORM				0.5 U				0.5 U							0.5 U
1 1 1-TRICHLOROETHANE				0.5 U				0.5 U							0.5 U
CARBON TETRACHLORIDE				0.5 U				0.5 U							0.5 U
BENZENE				0.5 U				0.5 U							0.5 U
1 2-DICHLOROETHANE				0.5 U				0.5 U							0.5 U
TRICHLOROETHENE				0.5 U				0.5 U							0.5 U
1 2-DICHLOROPROPANE				0.5 U				0.5 U							0.5 U
BROMODICHLOROMETHANE				0.5 U				0.5 U							0.5 U
CIS-1 3-DICHLOROPROPENE				0.5 U				0.5 U							0.5 U
MIBK				50 U				10 U							10 U
TOLUENE				0.5 U				0.5 U							0.5 U
TRANS-1 3-DICHLOROPROPENE				0.5 U				0.5 U							0.5 U
1 1 2-TRICHLOROETHANE				0.5 U				0.5 U							0.5 U
TETRACHLOROETHENE				0.5 U				0.5 U							0.5 U
2-HEXANONE				50 U				10 U							10 U
DIBROMOCHLOROMETHANE				0.5 U				0.5 U							0.5 U
CHLOROBENZENE				0.5 U				0.5 U							0.5 U
ETHYLBENZENE				0.5 U				0.5 U							0.5 U
P-XYLENE/M-XYLENE				0.5 U				0.5 U							0.5 U
O-XYLENE				0.5 U				0.5 U							0.5 U
STYRENE				0.5 U				0.5 U							0.5 U
BROMOFORM				0.5 U				0.5 U							0.5 U
1 1 2-TETRACHLOROETHANE				0.5 U				0.5 U							0.5 U

NOTES:

U = Below Practical Quantitation Limit (PQL)

Blank = Not sampled

WELL NUMBER 89-07(1A)  
ANALYTICAL SAMPLING RESULTS  
(concentrations in ug/L)

ANALYTE	1/97	4/97	7/97	10/28/97	4/98	AVG
CHLOROMETHANE				0.5 U		0.2
VINYL CHLORIDE				0.5 U		0.0
CHLOROETHANE				0.5 U		0.0
BROMOMETHANE				0.5 U		0.0
1 1-DICHLOROETHENE				0.5 U		0.0
ACETONE				10 U		0.0
CARBON DISULFIDE				0.5 U		0.2
METHYLENE CHLORIDE				0.5 U		0.0
TRANS-1 2-DICHLOROETHENE				0.5 U		0.0
1 1-DICHLOROETHANE				0.5 U		0.0
CIS-1 2-DICHLOROETHENE				0.5 U		0.0
METHYL ETHYL KETONE				10 U		0.0
CHLOROFORM				0.5 U		0.0
1 1 1-TRICHLOROETHANE				0.5 U		0.0
CARBON TETRACHLORIDE				0.5 U		0.0
BENZENE				0.5 U		0.0
1 2-DICHLOROETHANE				0.5 U		0.0
TRICHLOROETHENE				0.5 U		0.0
1 2-DICHLOROPROPANE				0.5 U		0.0
BROMODICHLOROMETHANE				0.5 U		0.0
CIS-1 3-DICHLOROPROPENE				0.5 U		0.0
MIBK				10 U		0.0
TOLUENE				0.5 U		0.0
TRANS-1 3-DICHLOROPROPENE				0.5 U		0.0
1 1 2-TRICHLOROETHANE				0.5 U		0.0
TETRACHLOROETHENE				0.5 U		0.0
2-HEXANONE				10 U		0.0
DIBROMOCHLOROMETHANE				0.5 U		0.0
CHLOROBENZENE				0.5 U		0.0
ETHYLBENZENE				0.5 U		0.0
P-XYLENE/M-XYLENE				0.5 U		0.0
O-XYLENE				0.5 U		0.0
STYRENE				0.5 U		0.0
BROMOFORM				0.5 U		0.0
1 1 2 2-TETRACHLOROETHANE				0.5 U		0.0

**NOTES:**

U = Below Practical Quantitation Limit (PQL)

Blank = Not sampled

WELL NUMBER 89-07(1B)  
ANALYTICAL SAMPLING RESULTS  
(Concentrations in ug/L)

ANALYTE	4/93	7/93	10/93	1/21/94	4/94	7/94	10/94	1/11/95	4/95	7/95	10/95	1/30/96	4/96	7/96	10/17/96
CHLOROMETHANE				0.5 U				0.5 U				0.5 U			0.6
VINYL CHLORIDE				0.5 U				0.5 U				0.5 U			0.5 U
CHLOROETHANE				0.5 U				0.5 U				0.5 U			0.5 U
BROMOMETHANE				0.5 U				0.5 U				0.5 U			0.5 U
1 1-DICHLOROETHENE				0.5 U				0.5 U				0.5 U			0.5 U
ACETONE				50 U				10 U				10 U			10 U
CARBON DISULFIDE				0.5 U				0.5 U				0.5 U			0.8
METHYLENE CHLORIDE				0.5 U				0.5 U				0.5 U			0.5 U
TRANS-1 2-DICHLOROETHENE				0.5 U				0.5 U				0.5 U			0.5 U
1 1-DICHLOROETHANE				0.5 U				0.5 U				0.5 U			0.5 U
CIS-1 2-DICHLOROETHENE				0.5 U				0.5 U				0.5 U			0.5 U
METHYL ETHYL KETONE				50 U				10 U				10 U			10 U
CHLOROFORM				0.5 U				0.5 U				0.5 U			0.5 U
1 1 1-TRICHLOROETHANE				0.5 U				0.5 U				0.5 U			0.5 U
CARBON TETRACHLORIDE				0.5 U				0.5 U				0.5 U			0.5 U
BENZENE				0.5 U				0.5 U				0.5 U			0.5 U
1 2-DICHLOROETHANE				0.5 U				0.5 U				0.5 U			0.5 U
TRICHLOROETHENE				0.5 U				0.5 U				0.5 U			0.5 U
1 2-DICHLOROPROPANE				0.5 U				0.5 U				0.5 U			0.5 U
BROMODICHLOROMETHANE				0.5 U				0.5 U				0.5 U			0.5 U
CIS-1 3-DICHLOROPROPENE				0.5 U				0.5 U				0.5 U			0.5 U
MIBK				50 U				10 U				10 U			10 U
TOLUENE				0.5 U				0.5 U				0.5 U			0.5 U
TRANS-1 3-DICHLOROPROPENE				0.5 U				0.5 U				0.5 U			0.5 U
1 1 2-TRICHLOROETHANE				0.5 U				0.5 U				0.5 U			0.5 U
TETRACHLOROETHENE				0.5 U				0.5 U				0.5 U			0.5 U
2-HEXANONE				50 U				10 U				10 U			10 U
DIBROMOCHLOROMETHANE				0.5 U				0.5 U				0.5 U			0.5 U
CHLOROBENZENE				0.5 U				0.5 U				0.5 U			0.5 U
ETHYLBENZENE				0.5 U				0.5 U				0.5 U			0.5 U
P-XYLENE/M-XYLENE				0.5 U				0.5 U				0.5 U			0.5 U
O-XYLENE				0.5 U				0.5 U				0.5 U			0.5 U
STYRENE				0.5 U				0.5 U				0.5 U			0.5 U
BROMOFORM				0.5 U				0.5 U				0.5 U			0.5 U
1 1 2-TETRACHLOROETHANE				0.5 U				0.5 U				1 U			0.5 U

**NOTES:**

U = Below Practical Quantitation Limit (PQL)

Blank = Not sampled

WELL NUMBER 89-07(1B)  
ANALYTICAL SAMPLING RESULTS  
(Concentrations in ug/L)

ANALYTE	1/97	4/97	7/97	10/28/97	4/98	AVG
CHLOROMETHANE				0.5 U		0.1
VINYL CHLORIDE				0.5 U		0.0
CHLOROETHANE				0.5 U		0.0
BROMOMETHANE				0.5 U		0.0
1 1-DICHLOROETHENE				0.5 U		0.0
ACETONE				10 U		0.0
CARBON DISULFIDE				0.5 U		0.2
METHYLENE CHLORIDE				0.5 U		0.0
TRANS-1 2-DICHLOROETHENE				0.5 U		0.0
1 1-DICHLOROETHANE				0.5 U		0.0
CIS-1 2-DICHLOROETHENE				0.5 U		0.0
METHYL ETHYL KETONE				10 U		0.0
CHLOROFORM				0.5 U		0.0
1 1 1-TRICHLOROETHANE				0.5 U		0.0
CARBON TETRACHLORIDE				0.5 U		0.0
BENZENE				0.5 U		0.0
1 2-DICHLOROETHANE				0.5 U		0.0
TRICHLOROETHENE				0.5 U		0.0
1 2-DICHLOROPROPANE				0.5 U		0.0
BROMODICHLOROMETHANE				0.5 U		0.0
CIS-1 3-DICHLOROPROPENE				0.5 U		0.0
MIBK				10 U		0.0
TOLUENE				0.5 U		0.0
TRANS-1 3-DICHLOROPROPENE				0.5 U		0.0
1 1 2-TRICHLOROETHANE				0.5 U		0.0
TETRACHLOROETHENE				0.5 U		0.0
2-HEXANONE				10 U		0.0
DIBROMOCHLOROMETHANE				0.5 U		0.0
CHLOROBENZENE				0.5 U		0.0
ETHYLBENZENE				0.5 U		0.0
P-XYLENE/M-XYLENE				0.5 U		0.0
O-XYLENE				0.5 U		0.0
STYRENE				0.5 U		0.0
BROMOFORM				0.5 U		0.0
1 1 2 2-TETRACHLOROETHANE				0.5 U		0.0

**NOTES:**

U = Below Practical Quantitation Limit (PQL)

Blank = Not sampled

WELL NUMBER 89-14(0)  
ANALYTICAL SAMPLING RESULTS  
(Concentrations in ug/L)

ANALYTE	4/93	7/21/93	10/93	1/21/94	4/94	7/20/94	10/94	1/11/95	4/95	7/95	10/95	1/31/96	4/17/96	7/96
CHLOROMETHANE		0.5 U		0.5 U		1 U		0.5 U				0.5 U	0.5 U	
VINYL CHLORIDE		0.5 U		0.5 U		1 U		0.5 U				0.5 U	0.5 U	
CHLOROETHANE		0.5 U		0.5 U		1 U		0.5 U				0.5 U	0.5 U	
BROMOMETHANE		0.5 U		0.5 U		1 U		0.5 U				0.5 U	0.5 U	
1 1-DICHLOROETHENE		0.5 U		0.5 U		1 U		0.5 U				0.5 U	0.5 U	
ACETONE		36		50 U		10 U		10 U				10 U	10 U	
CARBON DISULFIDE		0.5 U		0.5 U		1 U		0.5 U				0.5 U	0.5 U	
METHYLENE CHLORIDE		0.5 U		0.5 U		1 U		0.5 U				0.5 U	0.5 U	
TRANS-1 2-DICHLOROETHENE		0.5 U		0.5 U		1 U		0.5 U				0.5 U	0.5 U	
1 1-DICHLOROETHANE		0.5 U		0.5 U		1 U		0.5 U				0.5 U	0.5 U	
CIS-1 2-DICHLOROETHENE		0.5 U		0.5 U		1 U		0.5 U				0.5 U	0.5 U	
METHYL ETHYL KETONE		20 U		50 U		10 U		10 U				10 U	10 U	
CHLOROFORM		0.5 U		0.5 U		1 U		0.5 U				0.5 U	0.5 U	
1 1 1-TRICHLOROETHANE		0.5 U		0.5 U		1 U		0.5 U				0.5 U	0.5 U	
CARBON TETRACHLORIDE		0.5 U		0.5 U		1 U		0.5 U				0.5 U	0.5 U	
BENZENE		0.5 U		0.5 U		1 U		0.5 U				0.5 U	0.5 U	
1 2-DICHLOROETHANE		0.5 U		0.5 U		1 U		0.5 U				0.5 U	0.5 U	
TRICHLOROETHENE		0.5 U		0.5 U		1 U		0.5 U				0.5 U	0.5 U	
1 2-DICHLOROPROPANE		0.5 U		0.5 U		1 U		0.5 U				0.5 U	0.5 U	
BROMODICHLOROMETHANE		0.5 U		0.5 U		1 U		0.5 U				0.5 U	0.5 U	
CIS-1 3-DICHLOROPROPENE		0.5 U		0.5 U		1 U		0.5 U				0.5 U	0.5 U	
MIBK		20 U		50 U		10 U		10 U				10 U	10 U	
TOLUENE		0.5 U		0.5 U		1 U		0.5 U				0.5 U	0.5 U	
TRANS-1 3-DICHLOROPROPENE		0.5 U		0.5 U		1 U		0.5 U				0.5 U	0.5 U	
1 1 2-TRICHLOROETHANE		0.5 U		0.5 U		1 U		0.5 U				0.5 U	0.5 U	
TETRACHLOROETHENE		0.5 U		0.5 U		1 U		0.5 U				0.5 U	0.5 U	
2-HEXANONE		20 U		50 U		10 U		10 U				10 U	10 U	
DIBROMOCHLOROMETHANE		0.5 U		0.5 U		1 U		0.5 U				0.5 U	0.5 U	
CHLOROBENZENE		0.5 U		0.5 U		1 U		0.5 U				0.5 U	0.5 U	
ETHYLBENZENE		0.5 U		0.5 U		1 U		0.5 U				0.5 U	0.5 U	
P-XYLENE/M-XYLENE		0.5 U		0.5 U		1 U		0.5 U				0.5 U	0.5 U	
O-XYLENE		0.5 U		0.5 U		1 U		0.5 U				0.5 U	0.5 U	
STYRENE		0.5 U		0.5 U		1 U		0.5 U				0.5 U	0.5 U	
BROMOFORM		0.5 U		0.5 U		1 U		0.5 U				0.5 U	0.5 U	
1 1 2 2-TETRACHLOROETHANE		0.5 U		0.5 U		1 U		0.5 U				1 U	1 U	

**NOTES:**

U = Below Practical Quantitation Limit (PQL)

Blank = Not sampled

WELL NUMBER 89-14(0)  
ANALYTICAL SAMPLING RESULTS  
(Concentrations in ug/L)

ANALYTE	10/17/96	1/97	4/30/97	7/97	10/97	4/22/98	10/98	AVG
CHLOROMETHANE	0.5 U		0.5 U			1 U		0.0
VINYL CHLORIDE	0.5 U		0.5 U			1 U		0.0
CHLOROETHANE	0.5 U		0.5 U			1 U		0.0
BROMOMETHANE	0.5 U		0.5 U			1 U		0.0
1 1-DICHLOROETHENE	0.5 U		0.5 U			1 U		0.0
ACETONE	10 U		10 U			10 U		4.0
CARBON DISULFIDE	0.5 U		0.5 U			1 U		0.0
METHYLENE CHLORIDE	0.5 U		0.5 U			2 U		0.0
TRANS-1 2-DICHLOROETHENE	0.5 U		0.5 U			1 U		0.0
1 1-DICHLOROETHANE	0.5 U		0.5 U			1 U		0.0
CIS-1 2-DICHLOROETHENE	0.5 U		0.5 U			1 U		0.0
METHYL ETHYL KETONE	10 U		10 U			10 U		0.0
CHLOROFORM	0.5 U		0.5 U			1 U		0.0
1 1 1-TRICHLOROETHANE	0.5 U		0.5 U			1 U		0.0
CARBON TETRACHLORIDE	0.5 U		0.5 U			1 U		0.0
BENZENE	0.5 U		0.5 U			0.7 U		0.0
1 2-DICHLOROETHANE	0.5 U		0.5 U			1 U		0.0
TRICHLOROETHENE	0.5 U		0.5 U			1 U		0.0
1 2-DICHLOROPROPANE	0.5 U		0.5 U			1 U		0.0
BROMODICHLOROMETHANE	0.5 U		0.5 U			1 U		0.0
CIS-1 3-DICHLOROPROPENE	0.5 U		0.5 U			1 U		0.0
MIBK	10 U		10 U			10 U		0.0
TOLUENE	0.5 U		0.5 U			1 U		0.0
TRANS-1 3-DICHLOROPROPENE	0.5 U		0.5 U			1 U		0.0
1 1 2-TRICHLOROETHANE	0.5 U		0.5 U			1 U		0.0
TETRACHLOROETHENE	0.5 U		0.5 U			1 U		0.0
2-HEXANONE	10 U		10 U			10 U		0.0
DIBROMOCHLOROMETHANE	0.5 U		0.5 U			1 U		0.0
CHLOROBENZENE	0.5 U		0.5 U			1 U		0.0
ETHYLBENZENE	0.5 U		0.5 U			1 U		0.0
P-XYLENE/M-XYLENE	0.5 U		0.5 U			1 U		0.0
O-XYLENE	0.5 U		0.5 U			1 U		0.0
STYRENE	0.5 U		0.5 U			1 B		0.0
BROMOFORM	0.5 U		0.5 U			1 U		0.0
1 1 2 2-TETRACHLOROETHANE	0.5 U		0.5 U			1 U		0.0

**NOTES:**

U = Below Practical Quantitation Limit (PQL)

Blank = Not sampled

WELL NUMBER 89-14(1)  
ANALYTICAL SAMPLING RESULTS  
(Concentrations in ug/L)

ANALYTE	4/93	7/20/93	10/93	1/21/94	4/94	7/20/94	10/94	1/11/95	4/95	7/95	10/95	1/31/96	4/96	7/96	10/17/96
CHLOROMETHANE		5 U		5 U				25 U				50 U			25 U
VINYL CHLORIDE		10		64				69				50 U			25 U
CHLOROETHANE		5 U		5 U				25 U				50 U			25 U
BROMOMETHANE		5 U		5 U				25 U				50 U			25 U
1 1-DICHLOROETHENE		5 U		5 U				25 U				50 U			25 U
ACETONE		50 U		50 U				250 U				250 U			120 U
CARBON DISULFIDE		5 U		5				25 U				50 U			25 U
METHYLENE CHLORIDE		5 U		5 U				25 U				50 U			25 U
TRANS-1 2-DICHLOROETHENE		5 U		7				25 U				50 U			25 U
1 1-DICHLOROETHANE		7		13				25 U				50 U			25 U
CIS-1 2-DICHLOROETHENE		266		550 J				718				630			490
METHYL ETHYL KETONE		50 U		50 U				250 U				250 U			120 U
CHLOROFORM		5 U		5 U				25 U				50 U			25 U
1 1 1-TRICHLOROETHANE		27		30				25				50 U			26
CARBON TETRACHLORIDE		5 U		5 U				25 U				50 U			25 U
BENZENE		5 U		5 U				25 U				50 U			25 U
1 2-DICHLOROETHANE		5 U		24				25 U				50 U			25 U
TRICHLOROETHENE		16		5 U				42				50 U			25 U
1 2-DICHLOROPROPANE		5 U		5 U				25 U				50 U			25 U
BROMODICHLOROMETHANE		5 U		5 U				25 U				50 U			25 U
CIS-1 3-DICHLOROPROPENE		5 U		5 U				25 U				50 U			25 U
MIBK		50 U		50 U				250 U				250 U			50 U
TOLUENE		5 U		5 U				25 U				50 U			25 U
TRANS-1 3-DICHLOROPROPENE		5 U		5 U				25 U				50 U			25 U
1 1 2-TRICHLOROETHANE		5 U		5 U				25 U				50 U			25 U
TETRACHLOROETHENE		5 U		5 U				25 U				50 U			25 U
2-HEXANONE		50 U		50 U				250 U				250 U			50 U
DIBROMOCHLOROMETHANE		5 U		5 U				25 U				50 U			25 U
CHLOROBENZENE		5 U		5 U				25 U				50 U			25 U
ETHYLBENZENE		5 U		5 U				25 U				50 U			25 U
P-XYLENE/M-XYLENE		5 U		5 U				25 U				50 U			25 U
O-XYLENE		5 U		5 U				25 U				50 U			25 U
STYRENE		5 U		5 U				25 U				50 U			25 U
BROMOFORM		5 U		5 U				25 U				50 U			25 U
1 1 2 2-TETRACHLOROETHANE		5 U		5 U				25 U				50 U			25 U

**NOTES:**

U = Below Practical Quantitation Limit (PQL)

J = Estimated

Blank = Not sampled

WELL NUMBER 89-14(1)  
ANALYTICAL SAMPLING RESULTS  
(Concentrations in ug/L)

ANALYTE	1/97	4/97	7/97	10/30/97	4/98	10/28/98	AVG
CHLOROMETHANE				25 U		5 U	0.0
VINYL CHLORIDE				25 U		27	24.3
CHLOROETHANE				25 U		5 U	0.0
BROMOMETHANE				25 U		5 U	0.0
1 1-DICHLOROETHENE				25 U		5 U	0.0
ACETONE				120 U		50 U	0.0
CARBON DISULFIDE				25 U		5 U	0.7
METHYLENE CHLORIDE				25 U		5 U	0.0
TRANS-1 2-DICHLOROETHENE				25 U		5 U	1.0
1 1-DICHLOROETHANE				25 U		13	4.7
CIS-1 2-DICHLOROETHENE				350		500	422.0
METHYL ETHYL KETONE				120 U		50 U	0.0
CHLOROFORM				25 U		5 U	0.0
1 1 1-TRICHLOROETHANE				25 U		22	18.6
CARBON TETRACHLORIDE				25 U		5 U	0.0
BENZENE				25 U		4 U	0.0
1 2-DICHLOROETHANE				25 U		5 U	3.4
TRICHLOROETHENE				25 U		30	12.6
1 2-DICHLOROPROPANE				25 U		5 U	0.0
BROMODICHLOROMETHANE				25 U		5 U	0.0
CIS-1 3-DICHLOROPROPENE				25 U		5 U	0.0
MIBK				50 U		50 U	0.0
TOLUENE				25 U		5 U	0.0
TRANS-1 3-DICHLOROPROPENE				25 U		5 U	0.0
1 1 2-TRICHLOROETHANE				25 U		5 U	0.0
TETRACHLOROETHENE				25 U		5 U	0.0
2-HEXANONE				50 U		50 U	0.0
DIBROMOCHLOROMETHANE				25 U		5 U	0.0
CHLOROBENZENE				25 U		5 U	0.0
ETHYLBENZENE				25 U		5 U	0.0
P-XYLENE/M-XYLENE				25 U		5 U	0.0
O-XYLENE				25 U		5 U	0.0
STYRENE				25 U		5 U	0.0
BROMOFORM				25 U		5 U	0.0
1 1 2 2-TETRACHLOROETHANE				25 U		5 U	0.0

**NOTES:**

U = Below Practical Quantitation Limit (PQL)

J = Estimated

Blank = Not sampled



WELL NUMBER 89-15(1)  
ANALYTICAL SAMPLING RESULTS  
(Concentrations in ug/L)

ANALYTE	4/93	7/21/93	10/93	1/24/94	04/27/94	7/21/94	10/26/94	1/12/95	4/20/95	7/12/95	10/19/95	2/1/96
CHLOROMETHANE		2500 U		5000 U	5000 U	50 U	50 U	250 U	12500 U	25000 U	12500 U	5000 U
VINYL CHLORIDE		2500 U		5000 U	5000 U	50 U	50 U	250 U	12500 U	25000 U	12500 U	5000 U
CHLOROETHANE		2500 U		5000 U	5000 U	50 U	50 U	250 U	12500 U	25000 U	12500 U	5000 U
BROMOMETHANE		2500 U		5000 U	5000 U	50 U	50 U	250 U	12500 U	25000 U	12500 U	5000 U
1 1-DICHLOROETHENE		2500 U		5000 U	5000 U	50 U	50 U	250 U	12500 U	25000 U	12500 U	5000 U
ACETONE		25000 U		50000 U	50000 U	500 U	500 U	2500 U	125000 U	250000 U	125000 U	25000 U
CARBON DISULFIDE		2500 U		5000	5000 U	50 U	50 U	250 U	12500 U	25000 U	12500 U	5000 U
METHYLENE CHLORIDE		149000		228000	65200	1280	394000	448000	332000	524000	330000	72000
TRANS-1 2-DICHLOROETHENE		2500 U		5000 U	5000 U	50 U	50 U	250 U	12500 U	25000 U	12500 U	5000 U
1 1-DICHLOROETHANE		2500 U		5000 U	5000 U	50 U	50 U	250 U	12500 U	25000 U	12500 U	5000 U
CIS-1 2-DICHLOROETHENE		5700		10500	5000 U	530	4210	4950	12500 U	25000 U	12500 U	12000
METHYL ETHYL KETONE		25000 U		50000 U	50000 U	500 U	500 U	2500 U	125000 U	250000 U	125000 U	25000 U
CHLOROFORM		2500 U		5000 U	5000 U	50 U	50 U	250 U	12500 U	25000 U	12500 U	5000 U
1 1 1-TRICHLOROETHANE		2500 U		5000 U	5000 U	50 U	1670	250 U	12500 U	25000 U	12500 U	5000 U
CARBON TETRACHLORIDE		2500 U		5000 U	5000 U	50 U	50 U	250 U	12500 U	25000 U	12500 U	5000 U
BENZENE		2500 U		5000 U	5000 U	50 U	50 U	250 U	12500 U	25000 U	12500 U	5000 U
1 2-DICHLOROETHANE		2500 U		5000 U	5000 U	50 U	50 U	250 U	12500 U	25000 U	12500 U	5000 U
TRICHLOROETHENE		7540		702000	7520	1520	334000	82300	122000	366000	59000	62000
1 2-DICHLOROPROPANE		2500 U		5000 U	5000 U	50 U	50 U	250 U	12500 U	25000 U	12500 U	5000 U
BROMODICHLOROMETHANE		2500 U		5000 U	5000 U	50 U	50 U	250 U	12500 U	25000 U	12500 U	5000 U
CIS-1 3-DICHLOROPROPENE		2500 U		5000 U	5000 U	50 U	50 U	250 U	12500 U	25000 U	12500 U	5000 U
MIBK		25000 U		50000 U	50000 U	500 U	500 U	2500 U	125000 U	250000 U	125000 U	10000 U
TOLUENE		2500 U		5000 U	5000 U	50 U	50 U	250 U	12500 U	25000 U	12500 U	5000 U
TRANS-1 3-DICHLOROPROPENE		2500 U		5000 U	5000 U	50 U	50 U	250 U	12500 U	25000 U	12500 U	5000 U
1 1 2-TRICHLOROETHANE		2500 U		5000 U	5000 U	50 U	50 U	250 U	12500 U	25000 U	12500 U	5000 U
TETRACHLOROETHENE		2500 U		5000 U	5000 U	50 U	50 U	250 U	12500 U	25000 U	12500 U	5000 U
2-HEXANONE		25000 U		50000 U	50000 U	500 U	500 U	2500 U	125000 U	250000 U	125000 U	10000 U
DIBROMOCHLOROMETHANE		2500 U		5000 U	5000 U	50 U	50 U	250 U	12500 U	25000 U	12500 U	5000 U
CHLOROBENZENE		2500 U		5000 U	5000 U	50 U	50 U	250 U	12500 U	25000 U	12500 U	5000 U
ETHYLBENZENE		2500 U		5000 U	5000 U	50 U	50 U	250 U	12500 U	25000 U	12500 U	5000 U
P-XYLENE/M-XYLENE		2500 U		5000 U	5000 U	50 U	50 U	250 U	12500 U	25000 U	12500 U	5000 U
O-XYLENE		2500 U		5000 U	5000 U	50 U	50 U	250 U	12500 U	25000 U	12500 U	5000 U
STYRENE		2500 U		5000 U	5000 U	50 U	50 U	250 U	12500 U	25000 U	12500 U	5000 U
BROMOFORM		2500 U		5000 U	5000 U	50 U	50 U	250 U	12500 U	25000 U	12500 U	5000 U
1 1 2 2-TETRACHLOROETHANE		2500 U		5000 U	5000 U	50 U	50 U	250 U	12500 U	25000 U	12500 U	5000 U

**NOTES:**

U = Below Practical Quantitation Limit (PQL)

Blank = Not sampled

WELL NUMBER 89-15(1)  
 ANALYTICAL SAMPLING RESULTS  
 (Concentrations in ug/L)

ANALYTE	4/17/96	7/17/96	10/17/96	1/15/97	4/30/97	7/23/97	10/31/97	4/98	10/29/98	AVG
CHLOROMETHANE	5000 U	12500 U	1200 U	120 U	120 U	25 U	250 U		2500 U	0.0
VINYL CHLORIDE	5000 U	12500 U	1200 U	120 U	120 U	36	250 U		2500 U	2.0
CHLOROETHANE	5000 U	12500 U	1200 U	120 U	120 U	25 U	250 U		2500 U	0.0
BROMOMETHANE	5000 U	12500 U	1200 U	120 U	120 U	25 U	250 U		2500 U	0.0
1 1-DICHLOROETHENE	5000 U	12500 U	1200 U	120 U	120 U	25 U	250 U		2500 U	0.0
ACETONE	25000 U	62500 U	6200 U	620 U	620 U	500 U	1200 U		13000 U	0.0
CARBON DISULFIDE	5000 U	12500 U	1200 U	120 U	120 U	25 U	250 U		2500 U	277.8
METHYLENE CHLORIDE	180000	120000	20000	1600	3300	2500	1500		4500	159826.7
TRANS-1 2-DICHLOROETHENE	5000 U	12500 U	1200 U	120 U	120 U	25 U	250 U		2500 U	0.0
1 1-DICHLOROETHANE	5000 U	12500 U	1200 U	120 U	120 U	25 U	250 U		2500 U	0.0
CIS-1 2-DICHLOROETHENE	17000	12500 U	2000	2000	860	840	950		750 J	3418.9
METHYL ETHYL KETONE	25000 U	62500 U	6200 U	620 U	620 U	500 U	1200 U		13000 U	0.0
CHLOROFORM	5000 U	12500 U	1200 U	120 U	120 U	25 U	250 U		2500 U	0.0
1 1 1-TRICHLOROETHANE	5000 U	12500 U	1200 U	120 U	120 U	64	250 U		2500 U	96.3
CARBON TETRACHLORIDE	5000 U	12500 U	1200 U	120 U	120 U	25 U	250 U		2500 U	0.0
BENZENE	5000 U	12500 U	1200 U	120 U	120 U	25 U	250 U		2500 U	0.0
1 2-DICHLOROETHANE	5000 U	12500 U	1200 U	120 U	120 U	25 U	250 U		2500 U	0.0
TRICHLOROETHENE	75000	58000	21000	1700	6100	22000 E	6900		16000	107143.3
1 2-DICHLOROPROPANE	5000 U	12500 U	1200 U	120 U	120 U	25 U	250 U		2500 U	0.0
BROMODICHLOROMETHANE	5000 U	12500 U	1200 U	120 U	120 U	25 U	250 U		2500 U	0.0
CIS-1 3-DICHLOROPROPENE	5000 U	12500 U	1200 U	120 U	120 U	25 U	250 U		2500 U	0.0
MIBK	10000 U	25000 U	2500 U	250 U	250 U	500 U	500 U		5000 U	0.0
TOLUENE	5000 U	12500 U	1200 U	120 U	120 U	25 U	250 U		2500 U	0.0
TRANS-1 3-DICHLOROPROPENE	5000 U	12500 U	1200 U	120 U	120 U	25 U	250 U		2500 U	0.0
1 1 2-TRICHLOROETHANE	5000 U	12500 U	1200 U	120 U	120 U	25 U	250 U		2500 U	0.0
TETRACHLOROETHENE	5000 U	12500 U	1200 U	120 U	120 U	25 U	250 U		2500 U	0.0
2-HEXANONE	10000 U	25000 U	2500 U	250 U	250 U	500 U	500 U		5000 U	0.0
DIBROMOCHLOROMETHANE	5000 U	12500 U	1200 U	120 U	120 U	25 U	250 U		2500 U	0.0
CHLORO BENZENE	5000 U	12500 U	1200 U	120 U	120 U	25 U	250 U		2500 U	0.0
ETHYLBENZENE	5000 U	12500 U	1200 U	120 U	120 U	25 U	250 U		2500 U	0.0
P-XYLENE/M-XYLENE	5000 U	12500 U	1200 U	120 U	120 U	25 U	250 U		2500 U	0.0
O-XYLENE	5000 U	12500 U	1200 U	120 U	120 U	25 U	250 U		2500 U	0.0
STYRENE	5000 U	12500 U	1200 U	120 U	120 U	25 U	250 U		2500 U	0.0
BROMOFORM	5000 U	12500 U	1200 U	120 U	120 U	25 U	250 U		2500 U	0.0
1 1 2 2-TETRACHLOROETHANE	5000 U	12500 U	1200 U	120 U	120 U	25 U	250 U		2500 U	0.0

NOTES:

U = Below Practical Quantitation Limit (PQL)

Blank = Not sampled

WELL NUMBER 89-16(1)  
ANALYTICAL SAMPLING RESULTS  
ANALYTICAL METHOD EPA 8260  
(Concentrations in ug/L)

ANALYTE	4/93	7/93	10/93	1/18/94	4/94	7/94	10/94	1/10/95	4/95	7/95	10/95	1/31/96	4/96	7/96	10/15/96
CHLOROMETHANE				0.5 U				0.5 U				5 U			0.5 U
VINYL CHLORIDE				0.5 U				0.5 U				5 U			0.5 U
CHLOROETHANE				0.5 U				0.5 U				5 U			0.5 U
BROMOMETHANE				0.5 U				0.5 U				5 U			0.5 U
1 1-DICHLOROETHENE				0.5 U				0.5 U				5 U			0.5 U
ACETONE				50 U				10 U				25 U			10 U
CARBON DISULFIDE				0.5 U				0.5 U				5 U			1
METHYLENE CHLORIDE				0.5 U				0.5 U				5 U			0.5 U
TRANS-1 2-DICHLOROETHENE				0.5 U				0.5 U				5 U			0.5 U
1 1-DICHLOROETHANE				0.5 U				0.5 U				5 U			0.5 U
CIS-1 2-DICHLOROETHENE				0.5 U				0.5 U				5 U			0.5 U
METHYL ETHYL KETONE				50 U				10 U				25 U			10 U
CHLOROFORM				0.5 U				0.5 U				5 U			0.5 U
1 1 1-TRICHLOROETHANE				0.5 U				0.5 U				5 U			0.5 U
CARBON TETRACHLORIDE				0.5 U				0.5 U				5 U			0.5 U
BENZENE				0.5 U				0.5 U				5 U			0.5 U
1 2-DICHLOROETHANE				0.5 U				0.5 U				5 U			0.5 U
TRICHLOROETHENE				0.5 U				0.5 U				5 U			0.5 U
1 2-DICHLOROPROPANE				0.5 U				0.5 U				5 U			0.5 U
BROMODICHLOROMETHANE				0.5 U				0.5 U				5 U			0.5 U
CIS-1 3-DICHLOROPROPENE				0.5 U				0.5 U				5 U			0.5 U
MIBK				50 U				10 U				25 U			10 U
TOLUENE				0.5 U				0.5 U				5 U			0.5 U
TRANS-1 3-DICHLOROPROPENE				0.5 U				0.5 U				5 U			0.5 U
1 1 2-TRICHLOROETHANE				0.5 U				0.5 U				5 U			0.5 U
TETRACHLOROETHENE				0.5 U				0.5 U				5 U			0.5 U
2-HEXANONE				50 U				10 U				25 U			10 U
DIBROMOCHLOROMETHANE				0.5 U				0.5 U				5 U			0.5 U
CHLOROBENZENE				0.5 U				0.5 U				5 U			0.5 U
ETHYLBENZENE				0.5 U				0.5 U				5 U			0.5 U
P-XYLENE/M-XYLENE				0.5 U				0.5 U				5 U			0.5 U
O-XYLENE				0.5 U				0.5 U				5 U			0.5 U
STYRENE				0.5 U				0.5 U				5 U			0.5 U
BROMOFORM				0.5 U				0.5 U				5 U			0.5 U
1 1 2 2-TETRACHLOROETHANE				0.5 U				0.5 U				5 U			0.5 U

**NOTES:**

U = Below Practical Quantitation Limit (PQL)

Blank = Not sampled

WELL NUMBER 89-16(1)  
 ANALYTICAL SAMPLING RESULTS  
 ANALYTICAL METHOD EPA 8260  
 (Concentrations in ug/L)

ANALYTE	1/97	4/97	7/97	10/29/97	4/98	10/27/98	AVG
CHLOROMETHANE				0.5 U		1 U	0.0
VINYL CHLORIDE				0.5 U		1 U	0.0
CHLOROETHANE				0.5 U		1 U	0.0
BROMOMETHANE				0.5 U		1 U	0.0
1 1-DICHLOROETHENE				0.5 U		1 U	0.0
ACETONE				10 U		10 U	0.0
CARBON DISULFIDE				0.5 U		1 U	0.2
METHYLENE CHLORIDE				0.5 U		1 U	0.0
TRANS-1 2-DICHLOROETHENE				0.5 U		1 U	0.0
1 1-DICHLOROETHANE				0.5 U		1 U	0.0
CIS-1 2-DICHLOROETHENE				0.7		1 U	0.1
METHYL ETHYL KETONE				10 U		10 U	0.0
CHLOROFORM				0.5 U		1 U	0.0
1 1 1-TRICHLOROETHANE				0.5 U		1 U	0.0
CARBON TETRACHLORIDE				0.5 U		1 U	0.0
BENZENE				0.5 U		0.700 U	0.0
1 2-DICHLOROETHANE				0.5 U		1 U	0.0
TRICHLOROETHENE				0.5 U		1 U	0.0
1 2-DICHLOROPROPANE				0.5 U		1 U	0.0
BROMODICHLOROMETHANE				0.5 U		1 U	0.0
CIS-1 3-DICHLOROPROPENE				0.5 U		1 U	0.0
MIBK				10 U		10 U	0.0
TOLUENE				0.5 U		1 U	0.0
TRANS-1 3-DICHLOROPROPENE				0.5 U		1 U	0.0
1 1 2-TRICHLOROETHANE				0.5 U		1 U	0.0
TETRACHLOROETHENE				0.5 U		1 U	0.0
2-HEXANONE				10 U		10 U	0.0
DIBROMOCHLOROMETHANE				0.5 U		1 U	0.0
CHLOROBENZENE				0.5 U		1 U	0.0
ETHYLBENZENE				0.5 U		1 U	0.0
P-XYLENE/M-XYLENE				0.5 U		1 U	0.0
O-XYLENE				0.5 U		1 U	0.0
STYRENE				0.5 U		1 U	0.0
BROMOFORM				0.5 U		1 U	0.0
1 1 2 2-TETRACHLOROETHANE				0.5 U		1 U	0.0

## NOTES:

U = Below Practical Quantitation Limit (PQL)

Blank = Not sampled

WELL NUMBER 89-17(1)  
ANALYTICAL SAMPLING RESULTS  
(Concentrations in ug/L)

ANALYTE	4/93	7/93	10/93	1/20/94	4/94	7/94	10/94	1/10/95	4/95	7/95	10/95	1/30/96	4/96	7/96	10/15/96
CHLOROMETHANE				0.5 U				0.5 U				0.5 U			0.5 U
VINYL CHLORIDE				0.5 U				0.5 U				0.5 U			0.5 U
CHLOROETHANE				0.5 U				0.5 U				0.5 U			0.5 U
BROMOMETHANE				0.5 U				0.5 U				0.5 U			0.5 U
1 1-DICHLOROETHENE				0.5 U				0.5 U				0.5 U			0.5 U
ACETONE				50 U				10 U				10 U			10 U
CARBON DISULFIDE				0.5 U				0.5 U				0.5 U			0.6
METHYLENE CHLORIDE				0.5 U				0.5 U				0.5 U			0.5 U
TRANS-1 2-DICHLOROETHENE				0.5 U				0.5 U				0.5 U			0.5 U
1 1-DICHLOROETHANE				0.5 U				0.5 U				0.5 U			0.5 U
CIS-1 2-DICHLOROETHENE				0.5 U				0.5 U				0.5 U			0.5 U
METHYL ETHYL KETONE				50 U				10 U				10 U			10 U
CHLOROFORM				0.5 U				0.5 U				0.5 U			0.5 U
1 1 1-TRICHLOROETHANE				0.5 U				0.5 U				0.5 U			0.5 U
CARBON TETRACHLORIDE				0.5 U				0.5 U				0.5 U			0.5 U
BENZENE				0.5 U				0.5 U				0.5 U			0.5 U
1 2-DICHLOROETHANE				0.5 U				0.5 U				0.5 U			0.5 U
TRICHLOROETHENE				0.5 U				0.5 U				0.5 U			0.5 U
1 2-DICHLOROPROPANE				0.5 U				0.5 U				0.5 U			0.5 U
BROMODICHLOROMETHANE				0.5 U				0.5 U				0.5 U			0.5 U
CIS-1 3-DICHLOROPROPENE				0.5 U				0.5 U				0.5 U			0.5 U
MIBK				50 U				10 U				10 U			10 U
TOLUENE				0.5 U				0.5 U				0.5 U			0.5 U
TRANS-1 3-DICHLOROPROPENE				0.5 U				0.5 U				0.5 U			0.5 U
1 1 2-TRICHLOROETHANE				0.5 U				0.5 U				0.5 U			0.5 U
TETRACHLOROETHENE				0.5 U				0.5 U				0.5 U			0.5 U
2-HEXANONE				50 U				10 U				10 U			10 U
DIBROMOCHLOROMETHANE				0.5 U				0.5 U				0.5 U			0.5 U
CHLOROBENZENE				0.5 U				0.5 U				0.5 U			0.5 U
ETHYLBENZENE				0.5 U				0.5 U				0.5 U			0.5 U
P-XYLENE/M-XYLENE				0.5 U				0.5 U				0.5 U			0.5 U
O-XYLENE				0.5 U				0.5 U				0.5 U			0.5 U
STYRENE				0.5 U				0.5 U				0.5 U			0.5 U
BROMOFORM				0.5 U				0.5 U				0.5 U			0.5 U
1 1 2-TETRACHLOROETHANE				0.5 U				0.5 U				1 U			0.5 U

## NOTES:

U = Below Practical Quantitation Limit (PQL)

Blank = Not sampled

WELL NUMBER 89-17(1)  
ANALYTICAL SAMPLING RESULTS  
(Concentrations in ug/L)

ANALYTE	1/97	4/97	7/97	10/28/97	4/98	10/28/98	AVG
CHLOROMETHANE				0.5 U		1 U	0.0
VINYL CHLORIDE				0.5 U		1 U	0.0
CHLOROETHANE				0.5 U		1 U	0.0
BROMOMETHANE				0.5 U		1 U	0.0
1 1-DICHLOROETHENE				0.5 U		1 U	0.0
ACETONE				10 U		10 U	0.0
CARBON DISULFIDE				0.5 U		1 U	0.1
METHYLENE CHLORIDE				0.5 U		1 U	0.0
TRANS-1 2-DICHLOROETHENE				0.5 U		1 U	0.0
1 1-DICHLOROETHANE				0.5 U		1 U	0.0
CIS-1 2-DICHLOROETHENE				0.5 U		1 U	0.0
METHYL ETHYL KETONE				10 U		10 U	0.0
CHLOROFORM				0.5 U		1 U	0.0
1 1 1-TRICHLOROETHANE				0.5 U		1 U	0.0
CARBON TETRACHLORIDE				0.5 U		1 U	0.0
BENZENE				0.5 U		0.700 U	0.0
1 2-DICHLOROETHANE				0.5 U		1 U	0.0
TRICHLOROETHENE				0.5 U		1 U	0.0
1 2-DICHLOROPROPANE				0.5 U		1 U	0.0
BROMODICHLOROMETHANE				0.5 U		1 U	0.0
CIS-1 3-DICHLOROPROPENE				0.5 U		1 U	0.0
MIBK				10 U		10 U	0.0
TOLUENE				0.5 U		1 U	0.0
TRANS-1 3-DICHLOROPROPENE				0.5 U		1 U	0.0
1 1 2-TRICHLOROETHANE				0.5 U		1 U	0.0
TETRACHLOROETHENE				0.5 U		1 U	0.0
2-HEXANONE				10 U		10 U	0.0
DIBROMOCHLOROMETHANE				0.5 U		1 U	0.0
CHLOROBENZENE				0.5 U		1 U	0.0
ETHYLBENZENE				0.5 U		1 U	0.0
P-XYLENE/M-XYLENE				0.5 U		1 U	0.0
O-XYLENE				0.5 U		1 U	0.0
STYRENE				0.5 U		1 U	0.0
BROMOFORM				0.5 U		1 U	0.0
1 1 2 2-TETRACHLOROETHANE				0.5 U		1 U	0.0

**NOTES:**

U = Below Practical Quantitation Limit (PQL)

Blank = Not sampled

WELL NUMBER 89-18(1)  
ANALYTICAL SAMPLING RESULTS  
(Concentrations in ug/L)

ANALYTE	4/93	7/93	10/93	1/18/94	4/94	7/94	10/94	1/10/95	4/95	7/95	10/95	1/30/96	4/96	7/96	10/15/96
CHLOROMETHANE				0.5 U				0.5 U				0.5 U			0.5 U
VINYL CHLORIDE				0.5 U				0.5 U				0.5 U			0.5 U
CHLOROETHANE				0.5 U				0.5 U				0.5 U			0.5 U
BROMOMETHANE				0.5 U				0.5 U				0.5 U			0.5 U
1 1-DICHLOROETHENE				0.5 U				0.5 U				0.5 U			0.5 U
ACETONE				50 U				10 U				10 U			10 U
CARBON DISULFIDE				0.5 U				2				0.5 U			0.5 U
METHYLENE CHLORIDE				0.5 U				0.5 U				0.5 U			0.5 U
TRANS-1 2-DICHLOROETHENE				0.5 U				0.5 U				0.5 U			0.5 U
1 1-DICHLOROETHANE				0.5 U				0.5 U				0.5 U			0.5 U
CIS-1 2-DICHLOROETHENE				0.5 U				0.7				0.5 U			0.5 U
METHYL ETHYL KETONE				50 U				10 U				10 U			10 U
CHLOROFORM				0.5 U				0.5 U				0.5 U			0.5 U
1 1 1-TRICHLOROETHANE				0.5 U				0.5 U				0.5 U			0.5 U
CARBON TETRACHLORIDE				0.5 U				0.5 U				0.5 U			0.5 U
BENZENE				0.5 U				0.5 U				0.5 U			0.5 U
1 2-DICHLOROETHANE				0.5 U				0.5 U				0.5 U			0.5 U
TRICHLOROETHENE				0.5 U				0.5 U				0.5 U			0.5 U
1 2-DICHLOROPROPANE				0.5 U				0.5 U				0.5 U			0.5 U
BROMODICHLOROMETHANE				0.5 U				0.5 U				0.5 U			0.5 U
CIS-1 3-DICHLOROPROPENE				0.5 U				0.5 U				0.5 U			0.5 U
MIBK				50 U				10 U				10 U			10 U
TOLUENE				0.5 U				0.5 U				0.5 U			0.5 U
TRANS-1 3-DICHLOROPROPENE				0.5 U				0.5 U				0.5 U			0.5 U
1 1 2-TRICHLOROETHANE				0.5 U				0.5 U				0.5 U			0.5 U
TETRACHLOROETHENE				0.5 U				0.5 U				0.5 U			0.5 U
2-HEXANONE				50 U				10 U				10 U			10 U
DIBROMOCHLOROMETHANE				0.5 U				0.5 U				0.5 U			0.5 U
CHLOROBENZENE				0.5 U				0.5 U				0.5 U			0.5 U
ETHYLBENZENE				0.5 U				0.5 U				0.5 U			0.5 U
P-XYLENE/M-XYLENE				0.5 U				0.5 U				0.5 U			0.5 U
O-XYLENE				0.5 U				0.5 U				0.5 U			0.5 U
STYRENE				0.5 U				0.5 U				0.5 U			0.5 U
BROMOFORM				0.5 U				0.5 U				0.5 U			0.5 U
1 1 2 2-TETRACHLOROETHANE				0.5 U				0.5 U				1 U			0.5 U

**NOTES:**

U = Below Practical Quantitation Limit (PQL)

Blank = Not sampled

WELL NUMBER 89-18(1)  
ANALYTICAL SAMPLING RESULTS  
(Concentrations in ug/L)

ANALYTE	1/97	4/97	7/97	10/28/97	4/98	AVG
CHLOROMETHANE				0.5 U		0.0
VINYL CHLORIDE				0.5 U		0.0
CHLOROETHANE				0.5 U		0.0
BROMOMETHANE				0.5 U		0.0
1 1-DICHLOROETHENE				0.5 U		0.0
ACETONE				10 U		0.0
CARBON DISULFIDE				0.5 U		0.4
METHYLENE CHLORIDE				0.5 U		0.0
TRANS-1 2-DICHLOROETHENE				0.5 U		0.0
1 1-DICHLOROETHANE				0.5 U		0.0
CIS-1 2-DICHLOROETHENE				0.5 U		0.1
METHYL ETHYL KETONE				10 U		0.0
CHLOROFORM				0.5 U		0.0
1 1 1-TRICHLOROETHANE				0.5 U		0.0
CARBON TETRACHLORIDE				0.5 U		0.0
BENZENE				0.5 U		0.0
1 2-DICHLOROETHANE				0.5 U		0.0
TRICHLOROETHENE				0.5 U		0.0
1 2-DICHLOROPROPANE				0.5 U		0.0
BROMODICHLOROMETHANE				0.5 U		0.0
CIS-1 3-DICHLOROPROPENE				0.5 U		0.0
MIBK				10 U		0.0
TOLUENE				0.5 U		0.0
TRANS-1 3-DICHLOROPROPENE				0.5 U		0.0
1 1 2-TRICHLOROETHANE				0.5 U		0.0
TETRACHLOROETHENE				0.5 U		0.0
2-HEXANONE				10 U		0.0
DIBROMOCHLOROMETHANE				0.5 U		0.0
CHLOROBENZENE				0.5 U		0.0
ETHYLBENZENE				0.5 U		0.0
P-XYLENE/M-XYLENE				0.5 U		0.0
O-XYLENE				0.5 U		0.0
STYRENE				0.5 U		0.0
BROMOFORM				0.5 U		0.0
1 1 2 2-TETRACHLOROETHANE				0.5 U		0.0

**NOTES:**

U = Below Practical Quantitation Limit (PQL)

Blank = Not sampled



WELL NUMBER 93-02(1)  
 ANALYTICAL SAMPLING RESULTS  
 (Concentrations in ug/L)

ANALYTE	4/20/93	7/21/93	10/14/93	1/20/94	4/94	7/19/94	10/94	1/10/95	4/95	7/95	10/95	1/29/96	4/96	7/96
CHLOROMETHANE	5 U	5 U	5 U	5 U		50 U		5 U				100 U		
VINYL CHLORIDE	45	5 U	5 U	63		50 U		59				100 U		
CHLOROETHANE	5 U	5 U	5 U	5 U		50 U		5 U				100 U		
BROMOMETHANE	5 U	5 U	5 U	5 U		50 U		5 U				100 U		
1 1-DICHLOROETHENE	5 U	5 U	5 U	5 U		50 U		6				100 U		
ACETONE	50 U	50 U	50 U	50 U		500 U		50 U				500 U		
CARBON DISULFIDE	5 U	5 U	5 U	5		50 U		5 U				100 U		
METHYLENE CHLORIDE	5 U	37	5 U	5 U		50 U		5 U				100 U		
TRANS-1 2-DICHLOROETHENE	5 U	5 U	5 U	5 U		50 U		5 U				100 U		
1 1-DICHLOROETHANE	5 U	5 U	5 U	5 U		50 U		5 U				100 U		
CIS-1 2-DICHLOROETHENE	92	39	988 J	666		1170		1520				1000		
METHYL ETHYL KETONE	50 U	50 U	50 U	50 U		500 U		50 U				500 U		
CHLOROFORM	5 U	5 U	5 U	5 U		50 U		5 U				100 U		
1 1 1-TRICHLOROETHANE	5 U	5 U	5 U	5 U		50 U		6				100 U		
CARBON TETRACHLORIDE	5 U	5 U	5 U	5 U		50 U		5 U				100 U		
BENZENE	6	5 U	5 U	5 U		50 U		5 U				100 U		
1 2-DICHLOROETHANE	5 U	5 U	5 U	5 U		50 U		5 U				100 U		
TRICHLOROETHENE	5 U	5 U	20	5		91		34				100 U		
1 2-DICHLOROPROPANE	5 U	5 U	5 U	5 U		50 U		5 U				100 U		
BROMODICHLOROMETHANE	5 U	5 U	5 U	5 U		50 U		5 U				100 U		
CIS-1 3-DICHLOROPROPENE	5 U	5 U	5 U	5 U		50 U		5 U				100 U		
MIBK	50 U	50 U	50 U	50 U		500 U		50 U				500 U		
TOLUENE	5	5 U	5 U	5 U		50 U		5 U				100 U		
TRANS-1 3-DICHLOROPROPENE	5 U	5 U	5 U	5 U		50 U		5 U				100 U		
1 1 2-TRICHLOROETHANE	5 U	5 U	5 U	5 U		50 U		5 U				100 U		
TETRACHLOROETHENE	5 U	5 U	5 U	5 U		50 U		5 U				100 U		
2-HEXANONE	50 U	50 U	50 U	50 U		500 U		50 U				500 U		
DIBROMOCHLOROMETHANE	5 U	5 U	5 U	5 U		50 U		5 U				100 U		
CHLOROENZENE	5 U	5 U	5 U	5 U		50 U		5 U				100 U		
ETHYLBENZENE	5 U	5 U	5 U	5 U		50 U		5 U				100 U		
P-XYLENE/M-XYLENE	5 U	5 U	5 U	5 U		50 U		5 U				100 U		
O-XYLENE	5 U	5 U	5 U	5 U		50 U		5 U				100 U		
STYRENE	5 U	5 U	5 U	5 U		50 U		5 U				100 U		
BROMOFORM	5 U	5 U	5 U	5 U		50 U		5 U				100 U		
1 1 2 2-TETRACHLOROETHANE	5 U	5 U	5 U	5 U		50 U		5 U				100 U		

NOTES:

U = Below Practical Quantitation Limit (PQL)

J = Estimated

Blank = Not sampled

WELL NUMBER 93-02(1)  
ANALYTICAL SAMPLING RESULTS  
(Concentrations in ug/L)

ANALYTE	10/16/96	1/97	4/97	7/97	10/29/97	4/98	AVG
CHLOROMETHANE	25 U				25 U		0.0
VINYL CHLORIDE	90				130		43.0
CHLOROETHANE	25 U				25 U		0.0
BROMOMETHANE	25 U				25 U		0.0
1 1-DICHLOROETHENE	25 U				25 U		0.7
ACETONE	120 U				120 U		0.0
CARBON DISULFIDE	25 U				25 U		0.6
METHYLENE CHLORIDE	25 U				25 U		4.1
TRANS-1 2-DICHLOROETHENE	25 U				25 U		0.0
1 1-DICHLOROETHANE	25 U				25 U		0.0
CIS-1 2-DICHLOROETHENE	560				290		593.0
METHYL ETHYL KETONE	380				120 U		42.2
CHLOROFORM	25 U				25 U		0.0
1 1 1-TRICHLOROETHANE	25 U				25 U		0.7
CARBON TETRACHLORIDE	25 U				25 U		0.0
BENZENE	25 U				25 U		0.7
1 2-DICHLOROETHANE	25 U				25 U		0.0
TRICHLOROETHENE	25 U				25 U		16.7
1 2-DICHLOROPROPANE	25 U				25 U		0.0
BROMODICHLOROMETHANE	25 U				25 U		0.0
CIS-1 3-DICHLOROPROPENE	25 U				25 U		0.0
MIBK	50 U				50 U		0.0
TOLUENE	25 U				25 U		0.6
TRANS-1 3-DICHLOROPROPENE	25 U				25 U		0.0
1 1 2-TRICHLOROETHANE	25 U				25 U		0.0
TETRACHLOROETHENE	25 U				25 U		0.0
2-HEXANONE	50 U				50 U		0.0
DIBROMOCHLOROMETHANE	25 U				25 U		0.0
CHLOROBENZENE	25 U				25 U		0.0
ETHYLBENZENE	25 U				25 U		0.0
P-XYLENE/M-XYLENE	25 U				25 U		0.0
O-XYLENE	25 U				25 U		0.0
STYRENE	25 U				25 U		0.0
BROMOFORM	25 U				25 U		0.0
1 1 2 2-TETRACHLOROETHANE	25 U				25 U		0.0

**NOTES:**

U = Below Practical Quantitation Limit (PQL)

J = Estimated

Blank = Not sampled

WELL NUMBER 93-03(1)  
ANALYTICAL SAMPLING RESULTS  
(Concentrations in ug/L)

ANALYTE	4/20/93	7/93	10/13/93	1/21/94	4/94	7/19/94	10/94	1/10/95	4/95	7/95	10/95	1/29/96	4/19/96	7/17/96
CHLOROMETHANE	5 U	5 U	5 U	5 U		5 U		5 U				5 U	5 U	5 U
VINYL CHLORIDE	5 U	5 U	5 U	5 U		5 U		5 U				5 U	5 U	5 U
CHLOROETHANE	5 U	5 U	5 U	5 U		5 U		5 U				5 U	5 U	5 U
BROMOMETHANE	5 U	5 U	5 U	5 U		5 U		5 U				5 U	5 U	5 U
1 1-DICHLOROETHENE	5 U	5 U	5 U	5 U		5 U		5 U				5 U	5 U	5 U
ACETONE	63	108 J	50 U	50 U		50 U		50 U				25 U	25 U	25 U
CARBON DISULFIDE	5 U	5 U	5 U	5 U		5 U		5 U				5 U	5 U	5 U
METHYLENE CHLORIDE	5 U	5 U	5 U	5 U		5 U		5 U				5 U	5 U	5 U
TRANS-1 2-DICHLOROETHENE	5 U	5 U	5 U	5 U		5 U		5 U				5 U	5 U	5 U
1 1-DICHLOROETHANE	5 U	5 U	5 U	5 U		5 U		5 U				5 U	5 U	5 U
CIS-1 2-DICHLOROETHENE	11	5	5 U	5 U		5 U		5 U				5 U	5 U	5 U
METHYL ETHYL KETONE	50 U	50 U	50 U	50 U		50 U		50 U				25 U	25 U	25 U
CHLOROFORM	5 U	5 U	5 U	5 U		5 U		5 U				5 U	5 U	5 U
1 1 1-TRICHLOROETHANE	5 U	5 U	5 U	5 U		5 U		5 U				5 U	5 U	5 U
CARBON TETRACHLORIDE	5 U	5 U	5 U	5 U		5 U		5 U				5 U	5 U	5 U
BENZENE	5 U	5 U	5 U	5 U		5 U		5 U				5 U	5 U	5 U
1 2-DICHLOROETHANE	5 U	5 U	5 U	5 U		5 U		5 U				5 U	5 U	5 U
TRICHLOROETHENE	5 U	5 U	5 U	5 U		5 U		5 U				5 U	5 U	5 U
1 2-DICHLOROPROPANE	5 U	5 U	5 U	5 U		5 U		5 U				5 U	5 U	5 U
BROMODICHLOROMETHANE	5 U	5 U	5 U	5 U		5 U		5 U				5 U	5 U	5 U
CIS-1 3-DICHLOROPROPENE	5 U	5 U	5 U	5 U		5 U		5 U				5 U	5 U	5 U
MIBK	50 U	50 U	50 U	50 U		50 U		50 U				25 U	10 U	10 U
TOLUENE	5 U	5 U	5 U	5 U		5 U		5 U				5 U	5 U	5 U
TRANS-1 3-DICHLOROPROPENE	5 U	5 U	5 U	5 U		5 U		5 U				5 U	5 U	5 U
1 1 2-TRICHLOROETHANE	5 U	5 U	5 U	5 U		5 U		5 U				5 U	5 U	5 U
TETRACHLOROETHENE	5 U	5 U	5 U	5 U		5 U		5 U				5 U	5 U	5 U
2-HEXANONE	50 U	5 U	50 U	50 U		50 U		50 U				25 U	10 U	10 U
DIBROMOCHLOROMETHANE	5 U	5 U	5 U	5 U		5 U		5 U				5 U	5 U	5 U
CHLOROBENZENE	5 U	5 U	5 U	5 U		5 U		5 U				5 U	5 U	5 U
ETHYLBENZENE	5 U	5 U	5 U	5 U		5 U		5 U				5 U	5 U	5 U
P-XYLENE/M-XYLENE	5 U	5 U	5 U	5 U		5 U		5 U				5 U	5 U	5 U
O-XYLENE	5 U	5 U	5 U	5 U		5 U		5 U				5 U	5 U	5 U
STYRENE	5 U	5 U	5 U	5 U		5 U		5 U				5 U	5 U	5 U
BROMOFORM	5 U	5 U	5 U	5 U		5 U		5 U				5 U	5 U	5 U
1 1 2 2-TETRACHLOROETHANE	5 U	5 U	5 U	5 U		5 U		5 U				5 U	5 U	5 U

**NOTES:**

U = Below Practical Quantitation Limit (PQL)

J = Estimated

Blank = Not sampled

WELL NUMBER 93-03(1)  
ANALYTICAL SAMPLING RESULTS  
(Concentrations in ug/L)

ANALYTE	10/16/96	1/15/97	4/29/97	7/22/97	10/29/97	4/22/98	10/27/98	AVG
CHLOROMETHANE	5 U	5 U	0.5 U	0.5 U	0.5 U	1 U	5 U	0.0
VINYL CHLORIDE	5 U	5 U	0.5 U	0.5 U	0.5 U	1 U	5 U	0.0
CHLOROETHANE	5 U	5 U	0.5 U	0.5 U	0.5 U	1 U	5 U	0.0
BROMOMETHANE	5 U	5 U	0.5 U	0.5 U	0.5 U	1 U	5 U	0.0
1 1-DICHLOROETHENE	5 U	5 U	0.5 U	0.5 U	0.5 U	1 U	5 U	0.0
ACETONE	25 U	25 U	10 U	10 U	10 U	10 U	25 U	3.9
CARBON DISULFIDE	5 U	5 U	1	0.7	0.5 U	2	5 U	0.2
METHYLENE CHLORIDE	5 U	5 U	0.5 U	0.5 U	0.5 U	2 U	5 U	0.0
TRANS-1 2-DICHLOROETHENE	5 U	5 U	0.5 U	0.5 U	0.5 U	1 U	5 U	0.0
1 1-DICHLOROETHANE	5 U	5 U	0.5 U	0.5 U	0.5 U	1 U	5 U	0.0
CIS-1 2-DICHLOROETHENE	5 U	5 U	0.5 U	1	0.6	1 U	3 J	1.1
METHYL ETHYL KETONE	25 U	25 U	10 U	10 U	10 U	10 U	25 U	0.0
CHLOROFORM	5 U	5 U	0.5 U	0.5 U	0.5 U	1 U	5 U	0.0
1 1 1-TRICHLOROETHANE	5 U	5 U	0.5 U	0.5 U	0.5 U	1 U	5 U	0.0
CARBON TETRACHLORIDE	5 U	5 U	0.5 U	0.5 U	0.5 U	1 U	5 U	0.0
BENZENE	5 U	5 U	0.5 U	0.5 U	0.5 U	0.7 U	5 U	0.0
1 2-DICHLOROETHANE	5 U	5 U	0.5 U	0.5 U	0.5 U	1 U	5 U	0.0
TRICHLOROETHENE	5 U	5 U	0.5 U	0.5 U	0.5 U	1 U	5 U	0.0
1 2-DICHLOROPROPANE	5 U	5 U	0.5 U	0.5 U	0.5 U	1 U	5 U	0.0
BROMODICHLOROMETHANE	5 U	5 U	0.5 U	0.5 U	0.5 U	1 U	5 U	0.0
CIS-1 3-DICHLOROPROPENE	5 U	5 U	0.5 U	0.5 U	0.5 U	1 U	5 U	0.0
MIBK	10 U	10 U	10 U	10 U	10 U	10 U	10 U	0.0
TOLUENE	5 U	5 U	0.5 U	0.5 U	0.5 U	1 U	5 U	0.0
TRANS-1 3-DICHLOROPROPENE	5 U	5 U	0.5 U	0.5 U	0.5 U	1 U	5 U	0.0
1 1 2-TRICHLOROETHANE	5 U	5 U	0.5 U	0.5 U	0.5 U	1 U	5 U	0.0
TETRACHLOROETHENE	5 U	5 U	0.5 U	0.5 U	0.5 U	1 U	5 U	0.0
2-HEXANONE	10 U	10 U	10 U	10 U	10 U	10 U	10 U	0.0
DIBROMOCHLOROMETHANE	5 U	5 U	0.5 U	0.5 U	0.5 U	1 U	5 U	0.0
CHLOROBENZENE	5 U	5 U	0.5 U	0.5 U	0.5 U	1 U	5 U	0.0
ETHYLBENZENE	5 U	5 U	0.5 U	0.5 U	0.5 U	1 U	5 U	0.0
P-XYLENE/M-XYLENE	5 U	5 U	0.5 U	0.5 U	0.5 U	1 U	5 U	0.0
O-XYLENE	5 U	5 U	0.5 U	0.5 U	0.5 U	1 U	5 U	0.0
STYRENE	5 U	5 U	0.5 U	0.5 U	0.5 U	1 U	5 U	0.0
BROMOFORM	5 U	5 U	0.5 U	0.5 U	0.5 U	1 U	5 U	0.0
1 1 2 2-TETRACHLOROETHANE	5 U	5 U	0.5 U	0.5 U	0.5 U	1 U	5 U	0.0

**NOTES:**

U = Below Practical Quantitation Limit (PQL)

J = Estimated

Blank = Not sampled

WELL NUMBER 94-02(1)  
ANALYTICAL SAMPLING RESULTS  
(Concentrations in ug/L)

ANALYTE	4/93	7/93	10/93	1/94	4/94	7/94	10/94	1/9/95	4/95	7/95	10/95	1/30/96	4/96	7/96	10/15/96
CHLOROMETHANE								5 U				5 U			5 U
VINYL CHLORIDE								5 U				5 U			5 U
CHLOROETHANE								5 U				5 U			5 U
BROMOMETHANE								5 U				5 U			5 U
1 1-DICHLOROETHENE								5 U				5 U			5 U
ACETONE								50 U				25 U			25 U
CARBON DISULFIDE								5 U				5 U			5 U
METHYLENE CHLORIDE								5 U				5 U			5 U
TRANS-1 2-DICHLOROETHENE								5 U				5 U			5 U
1 1-DICHLOROETHANE								5 U				5 U			5 U
CIS-1 2-DICHLOROETHENE								5 U				5 U			5 U
METHYL ETHYL KETONE								50 U				25 U			25 U
CHLOROFORM								5 U				5 U			5 U
1 1 1-TRICHLOROETHANE								5 U				5 U			5 U
CARBON TETRACHLORIDE								5 U				5 U			5 U
BENZENE								5 U				5 U			5 U
1 2-DICHLOROETHANE								5 U				5 U			5 U
TRICHLOROETHENE								5 U				5 U			5 U
1 2-DICHLOROPROPANE								5 U				5 U			5 U
BROMODICHLOROMETHANE								5 U				5 U			5 U
CIS-1 3-DICHLOROPROPENE								5 U				5 U			5 U
MIBK								50 U				25 U			10 U
TOLUENE								5 U				5 U			5 U
TRANS-1 3-DICHLOROPROPENE								5 U				5 U			5 U
1 1 2-TRICHLOROETHANE								5 U				5 U			5 U
TETRACHLOROETHENE								5 U				5 U			5 U
2-HEXANONE								50 U				25 U			10 U
DIBROMOCHLOROMETHANE								5 U				5 U			5 U
CHLOROENZENE								5 U				5 U			5 U
ETHYLBENZENE								5 U				5 U			5 U
P-XYLENE/M-XYLENE								5 U				5 U			5 U
O-XYLENE								5 U				5 U			5 U
STYRENE								5 U				5 U			5 U
BROMOFORM								5 U				5 U			5 U
1 1 2-TETRACHLOROETHANE								5 U				5 U			5 U

**NOTES:**

U = Below Practical Quantitation Limit (PQL)

Blank = Not sampled

WELL NUMBER 94-02(1)  
ANALYTICAL SAMPLING RESULTS  
(Concentrations in ug/L)

ANALYTE	1/97	4/97	7/97	10/29/97	4/98	10/27/98	AVG
CHLOROMETHANE				0.5 U		1 U	0.0
VINYL CHLORIDE				0.5 U		1 U	0.0
CHLOROETHANE				0.5 U		1 U	0.0
BROMOMETHANE				0.5 U		1 U	0.0
1 1-DICHLOROETHENE				0.5 U		1 U	0.0
ACETONE				10 U		10 U	0.0
CARBON DISULFIDE				0.5 U		1 U	0.0
METHYLENE CHLORIDE				0.5 U		1 U	0.0
TRANS-1 2-DICHLOROETHENE				0.5 U		1 U	0.0
1 1-DICHLOROETHANE				0.5 U		1 U	0.0
CIS-1 2-DICHLOROETHENE				0.5 U		1 U	0.0
METHYL ETHYL KETONE				10 U		10 U	0.0
CHLOROFORM				0.5 U		1 U	0.0
1 1 1-TRICHLOROETHANE				0.5 U		1 U	0.0
CARBON TETRACHLORIDE				0.5 U		1 U	0.0
BENZENE				0.5 U		0.700 U	0.0
1 2-DICHLOROETHANE				0.5 U		1 U	0.0
TRICHLOROETHENE				0.5 U		1 U	0.0
1 2-DICHLOROPROPANE				0.5 U		1 U	0.0
BROMODICHLOROMETHANE				0.5 U		1 U	0.0
CIS-1 3-DICHLOROPROPENE				0.5 U		1 U	0.0
MIBK				10 U		10 U	0.0
TOLUENE				0.5 U		1 U	0.0
TRANS-1 3-DICHLOROPROPENE				0.5 U		1 U	0.0
1 1 2-TRICHLOROETHANE				0.5 U		1 U	0.0
TETRACHLOROETHENE				0.5 U		1 U	0.0
2-HEXANONE				10 U		10 U	0.0
DIBROMOCHLOROMETHANE				0.5 U		1 U	0.0
CHLOROBENZENE				0.5 U		1 U	0.0
ETHYLBENZENE				0.5 U		1 U	0.0
P-XYLENE/M-XYLENE				0.5 U		1 U	0.0
O-XYLENE				0.5 U		1 U	0.0
STYRENE				0.5 U		1 U	0.0
BROMOFORM				0.5 U		1 U	0.0
1 1 2 2-TETRACHLOROETHANE				0.5 U		1 U	0.0

## NOTES:

U = Below Practical Quantitation Limit (PQL)

Blank = Not sampled

WELL NUMBER B-8  
ANALYTICAL SAMPLING RESULTS  
(Concentrations in ug/L)

ANALYTE	4/93	7/93	10/93	1/20/94	4/94	7/94	10/94	1/11/95	4/95	7/95	10/95	2/1/96	4/96	7/96	10/16/96
CHLOROMETHANE								0.5 U				0.5 U			0.5 U
VINYL CHLORIDE								0.5 U				0.5 U			0.5 U
CHLOROETHANE								0.5 U				0.5 U			0.5 U
BROMOMETHANE								0.5 U				0.5 U			0.5 U
1 1-DICHLOROETHENE								0.5 U				0.5 U			0.5 U
ACETONE								10 U				10 U			10 U
CARBON DISULFIDE								0.5 U				0.5 U			0.5 U
METHYLENE CHLORIDE								0.5 U				0.5 U			0.5 U
TRANS-1 2-DICHLOROETHENE								0.5 U				0.5 U			0.5 U
1 1-DICHLOROETHANE								0.5 U				0.5 U			0.5 U
CIS-1 2-DICHLOROETHENE								0.5 U				0.5 U			0.5 U
METHYL ETHYL KETONE								10 U				10 U			10 U
CHLOROFORM								0.5 U				0.5 U			0.5 U
1 1 1-TRICHLOROETHANE								0.5 U				0.5 U			0.5 U
CARBON TETRACHLORIDE								0.5 U				0.5 U			0.5 U
BENZENE								0.5 U				0.5 U			0.5 U
1 2-DICHLOROETHANE								0.5 U				0.5 U			0.5 U
TRICHLOROETHENE								0.5 U				0.5 U			0.5 U
1 2-DICHLOROPROPANE								0.5 U				0.5 U			0.5 U
BROMODICHLOROMETHANE								0.5 U				0.5 U			0.5 U
CIS-1 3-DICHLOROPROPENE								0.5 U				0.5 U			0.5 U
MIBK								10 U				10 U			10 U
TOLUENE								0.5 U				0.5 U			0.5 U
TRANS-1 3-DICHLOROPROPENE								0.5 U				0.5 U			0.5 U
1 1 2-TRICHLOROETHANE								0.5 U				0.5 U			0.5 U
TETRACHLOROETHENE								0.5 U				0.5 U			0.5 U
2-HEXANONE								10 U				10 U			10 U
DIBROMOCHLOROMETHANE								0.5 U				0.5 U			0.5 U
CHLOROBENZENE								0.5 U				0.5 U			0.5 U
ETHYLBENZENE								0.5 U				0.5 U			0.5 U
P-XYLENE/M-XYLENE								0.5 U				0.5 U			0.5 U
O-XYLENE								0.5 U				0.5 U			0.5 U
STYRENE								0.5 U				0.5 U			0.5 U
BROMOFORM								0.5 U				0.5 U			0.5 U
1 1 2 2-TETRACHLOROETHANE								0.5 U				1 U			0.5 U

**NOTES:**

U = Below Practical Quantitation Limit (PQL)

Blank = Not sampled

WELL NUMBER B-8  
ANALYTICAL SAMPLING RESULTS  
(Concentrations in ug/L)

ANALYTE	1/97	4/97	7/97	10/30/97	4/98	10/30/98	AVG
CHLOROMETHANE				0.5 U		5 U	0.0
VINYL CHLORIDE				0.5 U		5 U	0.0
CHLOROETHANE				0.5 U		5 U	0.0
BROMOMETHANE				0.5 U		5 U	0.0
1 1-DICHLOROETHENE				0.5 U		5 U	0.0
ACETONE				12		25 U	2.4
CARBON DISULFIDE				0.5 U		5 U	0.0
METHYLENE CHLORIDE				0.5 U		5 U	0.0
TRANS-1 2-DICHLOROETHENE				0.5 U		5 U	0.0
1 1-DICHLOROETHANE				0.5 U		5 U	0.0
CIS-1 2-DICHLOROETHENE				0.5 U		5 U	0.0
METHYL ETHYL KETONE				10 U		25 U	0.0
CHLOROFORM				0.5 U		5 U	0.0
1 1 1-TRICHLOROETHANE				0.5 U		5 U	0.0
CARBON TETRACHLORIDE				0.5 U		5 U	0.0
BENZENE				0.5 U		5 U	0.0
1 2-DICHLOROETHANE				0.5 U		5 U	0.0
TRICHLOROETHENE				0.5 U		5 U	0.0
1 2-DICHLOROPROPANE				0.5 U		5 U	0.0
BROMODICHLOROMETHANE				0.5 U		5 U	0.0
CIS-1 3-DICHLOROPROPENE				0.5 U		5 U	0.0
MIBK				10 U		10 U	0.0
TOLUENE				0.5 U		5 U	0.0
TRANS-1 3-DICHLOROPROPENE				0.5 U		5 U	0.0
1 1 2-TRICHLOROETHANE				0.5 U		5 U	0.0
TETRACHLOROETHENE				0.5 U		5 U	0.0
2-HEXANONE				10 U		10 U	0.0
DIBROMOCHLOROMETHANE				0.5 U		5 U	0.0
CHLOROBENZENE				0.5 U		5 U	0.0
ETHYLBENZENE				0.5 U		5 U	0.0
P-XYLENE/M-XYLENE				0.5 U		5 U	0.0
O-XYLENE				0.5 U		5 U	0.0
STYRENE				0.5 U		5 U	0.0
BROMOFORM				0.5 U		5 U	0.0
1 1 2 2-TETRACHLOROETHANE				0.5 U		5 U	0.0

**NOTES:**

U = Below Practical Quantitation Limit (PQL)

Blank = Not sampled



WELL NUMBER B-14(1)  
ANALYTICAL SAMPLING RESULTS  
(Concentrations in ug/L)

ANALYTE	4/93	7/93	10/93	1/94	4/27/94	7/21/94	10/25/94	1/12/95	4/19/95	7/11/95	10/18/95	2/1/96	4/17/96
CHLOROMETHANE					5 U	25 U	25 U	5 U	25 U	25 U	50 U	50 U	25 U
VINYL CHLORIDE					115	119	118	110	109	131	350	140	120
CHLOROETHANE					5 U	25 U	25 U	5 U	25 U	25 U	50 U	50 U	25 U
BROMOMETHANE					5 U	25 U	25 U	5 U	25 U	25 U	50 U	50 U	25 U
1 1-DICHLOROETHENE					8	25 U	25 U	5 U	25 U	25 U	50 U	50 U	25 U
ACETONE					50 U	250 U	250 U	50 U	250 U	250 U	500 U	250 U	125 U
CARBON DISULFIDE					5 U	25 U	25 U	5 U	25 U	25 U	50 U	50 U	25 U
METHYLENE CHLORIDE					54	25 U	25 U	5 U	25 U	25 U	50 U	50 U	25 U
TRANS-1 2-DICHLOROETHENE					7	25 U	25 U	5 U	25 U	25 U	50 U	50 U	25 U
1 1-DICHLOROETHANE					26	25 U	25 U	15	25 U	25 U	50 U	50 U	25 U
CIS-1 2-DICHLOROETHENE					778	765	702	700	716	681	1400	680	620
METHYL ETHYL KETONE					50 U	250 U	250 U	50 U	250 U	250 U	500 U	250 U	125 U
CHLOROFORM					5 U	25 U	25 U	5 U	25 U	25 U	50 U	50 U	25 U
1 1 1-TRICHLOROETHANE					125	25 U	100	73	59	101	170	57	56
CARBON TETRACHLORIDE					5 U	25 U	25 U	5 U	25 U	25 U	50 U	50 U	25 U
BENZENE					5 U	25 U	25 U	5 U	25 U	25 U	50 U	50 U	25 U
1 2-DICHLOROETHANE					5 U	25 U	25 U	5 U	25 U	25 U	50 U	50 U	25 U
TRICHLOROETHENE					78	58	25 U	10	25 U	25 U	50 U	50 U	25 U
1 2-DICHLOROPROPANE					5 U	25 U	25 U	5 U	25 U	25 U	50 U	50 U	25 U
BROMODICHLOROMETHANE					5 U	25 U	25 U	5 U	25 U	25 U	50 U	50 U	25 U
CIS-1 3-DICHLOROPROPENE					5 U	25 U	25 U	5 U	25 U	25 U	50 U	50 U	25 U
MIBK					50 U	250 U	250 U	50 U	250 U	250 U	500 U	250 U	50 U
TOLUENE					5 U	25 U	25 U	5 U	25 U	25 U	50 U	50 U	25 U
TRANS-1 3-DICHLOROPROPENE					5 U	25 U	25 U	5 U	25 U	25 U	50 U	50 U	25 U
1 1 2-TRICHLOROETHANE					5 U	25 U	25 U	5 U	25 U	25 U	50 U	50 U	25 U
TETRACHLOROETHENE					5 U	25 U	25 U	5 U	25 U	25 U	50 U	50 U	25 U
2-HEXANONE					50 U	250 U	250 U	50 U	250 U	250 U	500 U	250 U	50 U
DIBROMOCHLOROMETHANE					5 U	25 U	25 U	5 U	25 U	25 U	50 U	50 U	25 U
CHLOROBENZENE					5 U	25 U	25 U	5 U	25 U	25 U	50 U	50 U	25 U
ETHYLBENZENE					5 U	25 U	25 U	5 U	25 U	25 U	50 U	50 U	25 U
P-XYLENE/M-XYLENE					5 U	25 U	25 U	5 U	25 U	25 U	50 U	50 U	25 U
O-XYLENE					5 U	25 U	25 U	5 U	25 U	25 U	50 U	50 U	25 U
STYRENE					5 U	25 U	25 U	5 U	25 U	25 U	50 U	50 U	25 U
BROMOFORM					5 U	25 U	25 U	5 U	25 U	25 U	50 U	50 U	25 U
1 1 2 2-TETRACHLOROETHANE					5 U	25 U	25 U	5 U	25 U	25 U	50 U	50 U	25 U

**NOTES:**

U = Below Practical Quantitation Limit (PQL)

Blank = Not sampled

WELL NUMBER B-14(1)  
ANALYTICAL SAMPLING RESULTS  
(Concentrations in ug/L)

ANALYTE	7/17/96	10/16/96	1/15/97	4/30/97	7/23/97	10/30/97	4/98	10/29/98	AVG
CHLOROMETHANE	25 U	25 U	25 U	2.5 U	2 U	25 U		5 U	0.0
VINYL CHLORIDE	120	120	120	130	110	140		100	134.5
CHLOROETHANE	25 U	25 U	25 U	2.5 U	2 U	25 U		5 U	0.0
BROMOMETHANE	25 U	25 U	25 U	2.5 U	2 U	25 U		5 U	0.0
1 1-DICHLOROETHENE	25 U	25 U	25 U	2.5 U	3	25 U		2 J	0.7
ACETONE	125 U	120 U	120 U	50 U	50 U	120 U		25 U	0.0
CARBON DISULFIDE	25 U	25 U	25 U	2.5 U	2 U	25 U		5 U	0.0
METHYLENE CHLORIDE	25 U	25 U	25 U	2.5 U	3	25 U		5 U	3.6
TRANS-1 2-DICHLOROETHENE	25 U	25 U	25 U	5	2 U	25 U		2 J	0.8
1 1-DICHLOROETHANE	25 U	25 U	25 U	17	16	25 U		9	5.2
CIS-1 2-DICHLOROETHENE	740	600	590	640	600	710		380 E	682.6
METHYL ETHYL KETONE	125 U	120 U	120 U	50 U	50 U	120 U		25 U	0.0
CHLOROFORM	25 U	25 U	25 U	2.5 U	2 U	25 U		5 U	0.0
1 1 1-TRICHLOROETHANE	89	70	65	73	63	79		33	75.8
CARBON TETRACHLORIDE	25 U	25 U	25 U	2.5 U	2 U	25 U		5 U	0.0
BENZENE	25 U	25 U	25 U	2.5 U	2 U	25 U		5 U	0.0
1 2-DICHLOROETHANE	25 U	25 U	25 U	2.5 U	2 U	25 U		5 U	0.0
TRICHLOROETHENE	25 U	26	25 U	7	5	25 U		3 J	11.5
1 2-DICHLOROPROPANE	25 U	25 U	25 U	2.5 U	2 U	25 U		5 U	0.0
BROMODICHLOROMETHANE	25 U	25 U	25 U	2.5 U	2 U	25 U		5 U	0.0
CIS-1 3-DICHLOROPROPENE	25 U	25 U	25 U	2.5 U	2 U	25 U		5 U	0.0
MIBK	50 U	50 U	50 U	50 U	50 U	50 U		10 U	0.0
TOLUENE	25 U	25 U	25 U	2.5 U	2 U	25 U		5 U	0.0
TRANS-1 3-DICHLOROPROPENE	25 U	25 U	25 U	2.5 U	2 U	25 U		5 U	0.0
1 1 2-TRICHLOROETHANE	25 U	25 U	25 U	2.5 U	2 U	25 U		5 U	0.0
TETRACHLOROETHENE	25 U	25 U	25 U	2.5 U	2 U	25 U		5 U	0.0
2-HEXANONE	50 U	50 U	50 U	50 U	50 U	50 U		10 U	0.0
DIBROMOCHLOROMETHANE	25 U	25 U	25 U	2.5 U	2 U	25 U		5 U	0.0
CHLOROBENZENE	25 U	25 U	25 U	2.5 U	2 U	25 U		5 U	0.0
ETHYLBENZENE	25 U	25 U	25 U	2.5 U	2 U	25 U		5 U	0.0
P-XYLENE/M-XYLENE	25 U	25 U	25 U	2.5 U	2 U	25 U		5 U	0.0
O-XYLENE	25 U	25 U	25 U	2.5 U	2 U	25 U		5 U	0.0
STYRENE	25 U	25 U	25 U	2.5 U	2 U	25 U		5 U	0.0
BROMOFORM	25 U	25 U	25 U	2.5 U	2 U	25 U		5 U	0.0
1 1 2 2-TETRACHLOROETHANE	25 U	25 U	25 U	2.5 U	2 U	25 U		5 U	0.0

## NOTES:

U = Below Practical Quantitation Limit (PQL)

Blank = Not sampled

WELL NUMBER DW-9  
ANALYTICAL SAMPLING RESULTS  
(Concentrations in ug/L)

ANALYTE	4/93	7/93	10/93	1/94	4/94	7/94	10/94	1/13/95	4/95	7/95	10/95	2/5/96	4/96	7/96	10/18/96
CHLOROMETHANE								5 U				50 U			120 U
VINYL CHLORIDE								46				250			140
CHLOROETHANE								5 U				50 U			120 U
BROMOMETHANE								5 U				50 U			120 U
1 1-DICHLOROETHENE								5 U				50 U			120 U
ACETONE								50 U				250 U			620 U
CARBON DISULFIDE								5 U				50 U			120 U
METHYLENE CHLORIDE								56				130			2500
TRANS-1 2-DICHLOROETHENE								6				50 U			120 U
1 1-DICHLOROETHANE								5 U				50 U			120 U
CIS-1 2-DICHLOROETHENE								703				2800			3200
METHYL ETHYL KETONE								50 U				250 U			620 U
CHLOROFORM								5 U				50 U			120 U
1 1 1-TRICHLOROETHANE								5 U				65			120 U
CARBON TETRACHLORIDE								5 U				50 U			120 U
BENZENE								5 U				50 U			120 U
1 2-DICHLOROETHANE								5 U				50 U			120 U
TRICHLOROETHENE								1400				2000			1600
1 2-DICHLOROPROPANE								5 U				50 U			120 U
BROMODICHLOROMETHANE								5 U				50 U			120 U
CIS-1 3-DICHLOROPROPENE								5 U				50 U			120 U
MIBK								50 U				250 U			250 U
TOLUENE								5 U				50 U			120 U
TRANS-1 3-DICHLOROPROPENE								5 U				50 U			120 U
1 1 2-TRICHLOROETHANE								5 U				50 U			120 U
TETRACHLOROETHENE								5 U				50 U			120 U
2-HEXANONE								50 U				250 U			250 U
DIBROMOCHLOROMETHANE								5 U				50 U			120 U
CHLOROBENZENE								5 U				50 U			120 U
ETHYLBENZENE								5 U				50 U			120 U
P-XYLENE/M-XYLENE								5 U				50 U			120 U
O-XYLENE								5 U				50 U			120 U
STYRENE								5 U				50 U			120 U
BROMOFORM								5 U				50 U			120 U
1 1 2 2-TETRACHLOROETHANE								5 U				50 U			120 U

**NOTES:**

U = Below Practical Quantitation Limit (PQL)

Blank = Not sampled

WELL NUMBER DW-9  
ANALYTICAL SAMPLING RESULTS  
(Concentrations in ug/L)

ANALYTE	1/97	4/97	7/97	10/30/97	4/23/98	10/30/98	AVG
CHLOROMETHANE				120 U	10 U	500 U	0.0
VINYL CHLORIDE				190	150	130 J	129.3
CHLOROETHANE				120 U	10 U	500 U	0.0
BROMOMETHANE				120 U	10 U	500 U	0.0
1 1-DICHLOROETHENE				120 U	21	500 U	3.5
ACETONE				620 U	100 U	2500 U	0.0
CARBON DISULFIDE				120 U	15	500 U	2.5
METHYLENE CHLORIDE				720	6300	500 U	1617.7
TRANS-1 2-DICHLOROETHENE				120 U	15	500 U	3.5
1 1-DICHLOROETHANE				120 U	28	500 U	4.7
CIS-1 2-DICHLOROETHENE				2600	3600	4200	2850.5
METHYL ETHYL KETONE				620 U	100 U	2500 U	0.0
CHLOROFORM				120 U	10 U	500 U	0.0
1 1 1-TRICHLOROETHANE				130	290	500 U	80.8
CARBON TETRACHLORIDE				120 U	10 U	500 U	0.0
BENZENE				120 U	7 U	500 U	0.0
1 2-DICHLOROETHANE				120 U	10 U	500 U	0.0
TRICHLOROETHENE				1100	4500	340 J	1766.7
1 2-DICHLOROPROPANE				120 U	10 U	500 U	0.0
BROMODICHLOROMETHANE				120 U	10 U	500 U	0.0
CIS-1 3-DICHLOROPROPENE				120 U	10 U	500 U	0.0
MIBK				250 U	100 U	1000 U	0.0
TOLUENE				120 U	10 U	500 U	0.0
TRANS-1 3-DICHLOROPROPENE				120 U	10 U	500 U	0.0
1 1 2-TRICHLOROETHANE				120 U	10 U	500 U	0.0
TETRACHLOROETHENE				120 U	10 U	500 U	0.0
2-HEXANONE				250 U	100 U	1000 U	0.0
DIBROMOCHLOROMETHANE				120 U	10 U	500 U	0.0
CHLOROBENZENE				120 U	10 U	500 U	0.0
ETHYLBENZENE				120 U	10 U	500 U	0.0
P-XYLENE/M-XYLENE				120 U	10 U	500 U	0.0
O-XYLENE				120 U	10 U	500 U	0.0
STYRENE				120 U	10 U	500 U	0.0
BROMOFORM				120 U	10 U	500 U	0.0
1 1 2 2-TETRACHLOROETHANE				120 U	10 U	500 U	0.0

**NOTES:**

U = Below Practical Quantitation Limit (PQL)

Blank = Not sampled

WELL NUMBER DW-10  
ANALYTICAL SAMPLING RESULTS  
(Concentrations in ug/L)

ANALYTE	4/93	7/93	10/93	1/94	4/94	7/94	10/94	1/13/95	4/95	7/95	10/95	2/5/96	4/96	7/96	10/18/96
CHLOROMETHANE								5 U				1250 U			1200 U
VINYL CHLORIDE								136				1250 U			1200 U
CHLOROETHANE								5 U				1250 U			1200 U
BROMOMETHANE								5 U				1250 U			1200 U
1 1-DICHLOROETHENE								5 U				1250 U			1200 U
ACETONE								50 U				6250 U			6200 U
CARBON DISULFIDE								5 U				1250 U			1200 U
METHYLENE CHLORIDE								27400				45000			14000
TRANS-1 2-DICHLOROETHENE								16				1250 U			1200 U
1 1-DICHLOROETHANE								17				1250 U			1200 U
CIS-1 2-DICHLOROETHENE								2150				3300			1200 U
METHYL ETHYL KETONE								50 U				6250 U			6200 U
CHLOROFORM								7				1250 U			1200 U
1 1 1-TRICHLOROETHANE								150				1250 U			1200 U
CARBON TETRACHLORIDE								22				1250 U			1200 U
BENZENE								5 U				1250 U			1200 U
1 2-DICHLOROETHANE								5 U				1250 U			1200 U
TRICHLOROETHENE								3890				4100			1200 U
1 2-DICHLOROPROPANE								5 U				1250 U			1200 U
BROMODICHLOROMETHANE								5 U				1250 U			1200 U
CIS-1 3-DICHLOROPROPENE								5 U				1250 U			1200 U
MIBK								50 U				6250 U			2500 U
TOLUENE								5 U				1250 U			1200 U
TRANS-1 3-DICHLOROPROPENE								5 U				1250 U			1200 U
1 1 2-TRICHLOROETHANE								5 U				1250 U			1200 U
TETRACHLOROETHENE								5 U				1250 U			1200 U
2-HEXANONE								50 U				6250 U			2500 U
DIBROMOCHLOROMETHANE								5 U				1250 U			1200 U
CHLOROBENZENE								5 U				1250 U			1200 U
ETHYLBENZENE								5 U				1250 U			1200 U
P-XYLENE/M-XYLENE								5 U				1250 U			1200 U
O-XYLENE								5 U				1250 U			1200 U
STYRENE								5 U				1250 U			1200 U
BROMOFORM								5 U				1250 U			1200 U
1 1 2-TETRACHLOROETHANE								5 U				1250 U			1200 U

**NOTES:**

U = Below Practical Quantitation Limit (PQL)

Blank = Not sampled

WELL NUMBER DW-10  
ANALYTICAL SAMPLING RESULTS  
(Concentrations in ug/L)

ANALYTE	1/97	4/97	7/97	10/30/97	4/23/98	10/29/98	AVG
CHLOROMETHANE				1000 U	200 U	200 U	0.0
VINYL CHLORIDE				1000 U	200 U	200 U	22.7
CHLOROETHANE				1000 U	200 U	200 U	0.0
BROMOMETHANE				1000 U	200 U	200 U	0.0
1 1-DICHLOROETHENE				1000 U	200 U	200 U	0.0
ACETONE				5000 U	2000 U	2000 U	0.0
CARBON DISULFIDE				1000 U	210	200 U	35.0
METHYLENE CHLORIDE				19000	15000	17000	22900.0
TRANS-1 2-DICHLOROETHENE				1000 U	200 U	200 U	2.7
1 1-DICHLOROETHANE				1000 U	200 U	200 U	2.8
CIS-1 2-DICHLOROETHENE				1000 U	610	1400	1243.3
METHYL ETHYL KETONE				5000 U	2000 U	2000 U	0.0
CHLOROFORM				1000 U	200 U	200 U	1.2
1 1 1-TRICHLOROETHANE				1000 U	200 U	200 U	25.0
CARBON TETRACHLORIDE				1000 U	200 U	200 U	3.7
BENZENE				1000 U	140 U	140 U	0.0
1 2-DICHLOROETHANE				1000 U	200 U	200 U	0.0
TRICHLOROETHENE				1300	950	1500	1956.7
1 2-DICHLOROPROPANE				1000 U	200 U	200 U	0.0
BROMODICHLOROMETHANE				1000 U	200 U	200 U	0.0
CIS-1 3-DICHLOROPROPENE				1000 U	200 U	200 U	0.0
MIBK				2000 U	2000 U	2000 U	0.0
TOLUENE				1000 U	200 U	200 U	0.0
TRANS-1 3-DICHLOROPROPENE				1000 U	200 U	200 U	0.0
1 1 2-TRICHLOROETHANE				1000 U	200 U	200 U	0.0
TETRACHLOROETHENE				1000 U	200 U	200 U	0.0
2-HEXANONE				2000 U	2000 U	2000 U	0.0
DIBROMOCHLOROMETHANE				1000 U	200 U	200 U	0.0
CHLOROBENZENE				1000 U	200 U	200 U	0.0
ETHYLBENZENE				1000 U	200 U	200 U	0.0
P-XYLENE/M-XYLENE				1000 U	200 U	200 U	0.0
O-XYLENE				1000 U	200 U	200 U	0.0
STYRENE				1000 U	200 U	200 U	0.0
BROMOFORM				1000 U	200 U	200 U	0.0
1 1 2 2-TETRACHLOROETHANE				1000 U	200 U	200 U	0.0

**NOTES:**

U = Below Practical Quantitation Limit (PQL)

Blank = Not sampled

WELL NUMBER DW-11  
 ANALYTICAL SAMPLING RESULTS  
 (Concentrations in ug/L)

ANALYTE	4/93	7/93	10/93	1/94	4/94	7/94	10/94	1/13/95	4/95	7/95	10/95	2/5/96	4/96	7/96	10/18/96
CHLOROMETHANE								25 U				50 U			500 U
VINYL CHLORIDE								123				210			500 U
CHLOROETHANE								25 U				50 U			500 U
BROMOMETHANE								25 U				50 U			500 U
1 1-DICHLOROETHENE								25 U				50 U			500 U
ACETONE								250 U				250 U			2500 U
CARBON DISULFIDE								25 U				50 U			500 U
METHYLENE CHLORIDE								1670				6500			2700
TRANS-1 2-DICHLOROETHENE								25 U				50 U			500 U
1 1-DICHLOROETHANE								25 U				50 U			500 U
CIS-1 2-DICHLOROETHENE								2360				2100			3200
METHYL ETHYL KETONE								250 U				250 U			2500 U
CHLOROFORM								25 U				50 U			500 U
1 1 1-TRICHLOROETHANE								249				180			500 U
CARBON TETRACHLORIDE								25 U				50 U			500 U
BENZENE								25 U				50 U			500 U
1 2-DICHLOROETHANE								25 U				50 U			500 U
TRICHLOROETHENE								10500				12000			11000
1 2-DICHLOROPROPANE								25 U				50 U			500 U
BROMODICHLOROMETHANE								25 U				50 U			500 U
CIS-1 3-DICHLOROPROPENE								25 U				50 U			500 U
MIBK								250 U				250 U			1000 U
TOLUENE								25 U				50 U			500 U
TRANS-1 3-DICHLOROPROPENE								25 U				50 U			500 U
1 1 2-TRICHLOROETHANE								25 U				50 U			500 U
TETRACHLOROETHENE								25 U				50 U			500 U
2-HEXANONE								250 U				250 U			1000 U
DIBROMOCHLOROMETHANE								25 U				50 U			500 U
CHLORO BENZENE								25 U				50 U			500 U
ETHYLBENZENE								25 U				50 U			500 U
P-XYLENE/M-XYLENE								25 U				50 U			500 U
O-XYLENE								25 U				50 U			500 U
STYRENE								25 U				50 U			500 U
BROMOFORM								25 U				50 U			500 U
1 1 2 2-TETRACHLOROETHANE								25 U				50 U			500 U

NOTES:

U = Below Practical Quantitation Limit (PQL)

Blank = Not sampled

WELL NUMBER DW-11  
ANALYTICAL SAMPLING RESULTS  
(Concentrations in ug/L)

ANALYTE	1/97	4/97	7/97	10/30/97	4/22/98	10/29/98	AVG
CHLOROMETHANE				500 U	100 U	100 U	0.0
VINYL CHLORIDE				500 U	150	230	118.8
CHLOROETHANE				500 U	100 U	100 U	0.0
BROMOMETHANE				500 U	100 U	100 U	0.0
1 1-DICHLOROETHENE				500 U	100 U	100 U	0.0
ACETONE				2500 U	1000 U	1000 U	0.0
CARBON DISULFIDE				500 U	100 U	100 U	0.0
METHYLENE CHLORIDE				3800	5400	5800	4311.7
TRANS-1 2-DICHLOROETHENE				500 U	100 U	100 U	0.0
1 1-DICHLOROETHANE				500 U	100 U	100 U	0.0
CIS-1 2-DICHLOROETHENE				3300	2800	4000	2960.0
METHYL ETHYL KETONE				2500 U	1000 U	1000 U	0.0
CHLOROFORM				500 U	100 U	100 U	0.0
1 1 1-TRICHLOROETHANE				1000	620	760	468.2
CARBON TETRACHLORIDE				500 U	100 U	100 U	0.0
BENZENE				500 U	70 U	70 U	0.0
1 2-DICHLOROETHANE				500 U	100 U	100 U	0.0
TRICHLOROETHENE				15000	15000	14000	12916.7
1 2-DICHLOROPROPANE				500 U	100 U	100 U	0.0
BROMODICHLOROMETHANE				500 U	100 U	100 U	0.0
CIS-1 3-DICHLOROPROPENE				500 U	100 U	100 U	0.0
MIBK				1000 U	1000 U	1000 U	0.0
TOLUENE				500 U	100 U	100 U	0.0
TRANS-1 3-DICHLOROPROPENE				500 U	100 U	100 U	0.0
1 1 2-TRICHLOROETHANE				500 U	100 U	100 U	0.0
TETRACHLOROETHENE				500 U	100 U	100 U	0.0
2-HEXANONE				1000 U	1000 U	1000 U	0.0
DIBROMOCHLOROMETHANE				500 U	100 U	100 U	0.0
CHLOROBENZENE				500 U	100 U	100 U	0.0
ETHYLBENZENE				500 U	100 U	100 U	0.0
P-XYLENE/M-XYLENE				500 U	100 U	100 U	0.0
O-XYLENE				500 U	100 U	100 U	0.0
STYRENE				500 U	100 U	100 U	0.0
BROMOFORM				500 U	100 U	100 U	0.0
1 1 2 2-TETRACHLOROETHANE				500 U	100 U	100 U	0.0

## NOTES:

U = Below Practical Quantitation Limit (PQL)

Blank = Not sampled



WELL NUMBER DW-12  
ANALYTICAL SAMPLING RESULTS  
(Concentrations in ug/L)

ANALYTE	4/93	7/93	10/93	1/94	4/94	7/94	10/94	1/13/95	4/95	7/95	10/95	2/5/96	4/96	7/96	10/18/96
CHLOROMETHANE								5 U				25 U			25 U
VINYL CHLORIDE								15				25 U			46
CHLOROETHANE								5 U				25 U			25 U
BROMOMETHANE								5 U				25 U			25 U
1 1-DICHLOROETHENE								5 U				25 U			25 U
ACETONE								50 U				125 U			120 U
CARBON DISULFIDE								5 U				25 U			25 U
METHYLENE CHLORIDE								159				52			710
TRANS-1 2-DICHLOROETHENE								5 U				25 U			25 U
1 1-DICHLOROETHANE								7				25 U			25 U
CIS-1 2-DICHLOROETHENE								592				580			3600
METHYL ETHYL KETONE								50 U				125 U			120 U
CHLOROFORM								5 U				25 U			25 U
1 1 1-TRICHLOROETHANE								35				27			68
CARBON TETRACHLORIDE								5 U				25 U			25 U
BENZENE								5 U				25 U			25 U
1 2-DICHLOROETHANE								5 U				25 U			25 U
TRICHLOROETHENE								639				130			9300
1 2-DICHLOROPROPANE								5 U				25 U			25 U
BROMODICHLOROMETHANE								5 U				25 U			25 U
CIS-1 3-DICHLOROPROPENE								5 U				25 U			25 U
MIBK								50 U				125 U			50 U
TOLUENE								5 U				25 U			25 U
TRANS-1 3-DICHLOROPROPENE								5 U				25 U			25 U
1 1 2-TRICHLOROETHANE								5 U				25 U			25 U
TETRACHLOROETHENE								5 U				25 U			25 U
2-HEXANONE								50 U				125 U			50 U
DIBROMOCHLOROMETHANE								5 U				25 U			25 U
CHLOROBENZENE								5 U				25 U			25 U
ETHYLBENZENE								5 U				25 U			25 U
P-XYLENE/M-XYLENE								5 U				25 U			25 U
O-XYLENE								5 U				25 U			25 U
STYRENE								5 U				25 U			25 U
BROMOFORM								5 U				25 U			25 U
1 1 2-TETRACHLOROETHANE								5 U				25 U			25 U

**NOTES:**

U = Below Practical Quantitation Limit (PQL)

Blank = Not sampled

WELL NUMBER DW-12  
ANALYTICAL SAMPLING RESULTS  
(Concentrations in ug/L)

ANALYTE	1/97	4/97	7/97	10/30/97	4/22/98	10/29/98	AVG
CHLOROMETHANE				500 U	100 U	500 U	0.0
VINYL CHLORIDE				500 U	120	420	100.2
CHLOROETHANE				500 U	100 U	500 U	0.0
BROMOMETHANE				500 U	100 U	500 U	0.0
1 1-DICHLOROETHENE				500 U	100 U	500 U	0.0
ACETONE				2500 U	1100 B	2500 U	0.0
CARBON DISULFIDE				500 U	100 U	500 U	0.0
METHYLENE CHLORIDE				1500	530	270	536.8
TRANS-1 2-DICHLOROETHENE				500 U	100 U	500 U	0.0
1 1-DICHLOROETHANE				500 U	100 U	500 U	1.2
CIS-1 2-DICHLOROETHENE				5300	5800	6600	3745.3
METHYL ETHYL KETONE				2500 U	1000 U	2500 U	0.0
CHLOROFORM				500 U	100 U	500 U	0.0
1 1 1-TRICHLOROETHANE				500 U	100 U	500 U	21.7
CARBON TETRACHLORIDE				500 U	100 U	500 U	0.0
BENZENE				500 U	70 U	500 U	0.0
1 2-DICHLOROETHANE				500 U	100 U	500 U	0.0
TRICHLOROETHENE				9600	7300	6100	5511.5
1 2-DICHLOROPROPANE				500 U	100 U	500 U	0.0
BROMODICHLOROMETHANE				500 U	100 U	500 U	0.0
CIS-1 3-DICHLOROPROPENE				500 U	100 U	500 U	0.0
MIBK				1000 U	1000 U	1000 U	0.0
TOLUENE				500 U	100 U	500 U	0.0
TRANS-1 3-DICHLOROPROPENE				500 U	100 U	500 U	0.0
1 1 2-TRICHLOROETHANE				500 U	100 U	500 U	0.0
TETRACHLOROETHENE				500 U	100 U	500 U	0.0
2-HEXANONE				1000 U	1000 U	1000 U	0.0
DIBROMOCHLOROMETHANE				500 U	100 U	500 U	0.0
CHLOROBENZENE				500 U	100 U	500 U	0.0
ETHYLBENZENE				500 U	100 U	500 U	0.0
P-XYLENE/M-XYLENE				500 U	100 U	500 U	0.0
O-XYLENE				500 U	100 U	500 U	0.0
STYRENE				500 U	100 U	500 U	0.0
BROMOFORM				500 U	100 U	500 U	0.0
1 1 2 2-TETRACHLOROETHANE				500 U	100 U	500 U	0.0

**NOTES:**

U = Below Practical Quantitation Limit (PQL)

Blank = Not sampled

WELL NUMBER EW-2  
ANALYTICAL SAMPLING RESULTS  
(Concentrations in ug/L)

ANALYTE	4/15/93	7/21/93	10/14/93	1/17/94	4/94	7/19/94	10/94	1/10/95	4/95	7/95	10/95	1/29/96	4/96	7/96
CHLOROMETHANE	5 U	5 U	500 U	500 U		250 U		250 U				125 U		
VINYL CHLORIDE	100	83	500 U	500 U		250 U		250 U				125 U		
CHLOROETHANE	5 U	5 U	500 U	500 U		250 U		250 U				125 U		
BROMOMETHANE	5 U	5 U	500 U	500 U		250 U		250 U				125 U		
1 1-DICHLOROETHENE	33	12	500 U	500 U		250 U		250 U				125 U		
ACETONE	50 U	50 U	5000 U	5000 U		2500 U		2500 U				625 U		
CARBON DISULFIDE	5 U	5 U	500 U	500 U		250 U		250 U				125 U		
METHYLENE CHLORIDE	21	6 U	500 U	500 U		250 U		250 U				125 U		
TRANS-1 2-DICHLOROETHENE	16	12	500 U	500 U		250 U		250 U				125 U		
1 1-DICHLOROETHANE	8	11	500 U	500 U		250 U		250 U				125 U		
CIS-1 2-DICHLOROETHENE	5460	4760	5000	4710		5750		1740				2100		
METHYL ETHYL KETONE	50 U	50 U	5000 U	5000 U		2500 U		2500 U				625 U		
CHLOROFORM	5 U	5 U	500 U	500 U		250 U		250 U				125 U		
1 1 1-TRICHLOROETHANE	59	57	500 U	500 U		250 U		250 U				125 U		
CARBON TETRACHLORIDE	5 U	5 U	500 U	500 U		250 U		250 U				125 U		
BENZENE	5 U	5 U	500 U	500 U		250 U		250 U				125 U		
1 2-DICHLOROETHANE	5 U	5 U	500 U	500 U		250 U		250 U				125 U		
TRICHLOROETHENE	1700	1970	1390	2540		4310		2010				850		
1 2-DICHLOROPROPANE	5 U	5 U	500 U	500 U		250 U		250 U				125 U		
BROMODICHLOROMETHANE	5 U	5 U	500 U	500 U		250 U		250 U				125 U		
CIS-1 3-DICHLOROPROPENE	5 U	5 U	500 U	500 U		250 U		250 U				125 U		
MIBK	50 U	50 U	5000 U	5000 U		2500 U		2500 U				625 U		
TOLUENE	5 U	5 U	500 U	500 U		250 U		250 U				125 U		
TRANS-1 3-DICHLOROPROPENE	5 U	5 U	500 U	500 U		250 U		250 U				125 U		
1 1 2-TRICHLOROETHANE	5 U	5 U	500 U	500 U		250 U		250 U				125 U		
TETRACHLOROETHENE	5 U	5 U	500 U	500 U		250 U		250 U				125 U		
2-HEXANONE	50 U	50 U	5000 U	5000 U		2500 U		2500 U				625 U		
DIBROMOCHLOROMETHANE	5 U	5 U	500 U	500 U		250 U		250 U				125 U		
CHLOROBENZENE	5 U	5 U	500 U	500 U		250 U		250 U				125 U		
ETHYLBENZENE	5 U	5 U	500 U	500 U		250 U		250 U				125 U		
P-XYLENE/M-XYLENE	5 U	5 U	500 U	500 U		250 U		250 U				125 U		
O-XYLENE	5 U	5 U	500 U	500 U		250 U		250 U				125 U		
STYRENE	5 U	5 U	500 U	500 U		250 U		250 U				125 U		
BROMOFORM	5 U	5 U	500 U	500 U		250 U		250 U				125 U		
1 1 2-TETRACHLOROETHANE	5 U	5 U	500 U	500 U		250 U		250 U				125 U		

**NOTES:**

U = Below Practical Quantitation Limit (PQL)

Blank = Not sampled

WELL NUMBER EW-2  
ANALYTICAL SAMPLING RESULTS  
(Concentrations in ug/L)

ANALYTE	10/16/96	1/97	4/97	7/97	10/29/97	4/98	10/27/98	AVG
CHLOROMETHANE	120 U				120 U		130 U	0.0
VINYL CHLORIDE	120 U				120 U		170	35.3
CHLOROETHANE	120 U				120 U		130 U	0.0
BROMOMETHANE	120 U				120 U		130 U	0.0
1 1-DICHLOROETHENE	120 U				120 U		130 U	4.5
ACETONE	620 U				620 U		630 U	0.0
CARBON DISULFIDE	120 U				120 U		130 U	0.0
METHYLENE CHLORIDE	120 U				120 U		130 U	2.1
TRANS-1 2-DICHLOROETHENE	120 U				120 U		130 U	2.8
1 1-DICHLOROETHANE	120 U				120 U		130 U	1.9
CIS-1 2-DICHLOROETHENE	1900				2200		2400	3602.0
METHYL ETHYL KETONE	620 U				620 U		630 U	0.0
CHLOROFORM	120 U				120 U		130 U	0.0
1 1 1-TRICHLOROETHANE	120 U				120 U		130 U	11.6
CARBON TETRACHLORIDE	120 U				120 U		130 U	0.0
BENZENE	120 U				120 U		130 U	0.0
1 2-DICHLOROETHANE	120 U				120 U		130 U	0.0
TRICHLOROETHENE	330				120 U		50 J	1510.0
1 2-DICHLOROPROPANE	120 U				120 U		130 U	0.0
BROMODICHLOROMETHANE	120 U				120 U		130 U	0.0
CIS-1 3-DICHLOROPROPENE	120 U				120 U		130 U	0.0
MIBK	250 U				250 U		250 U	0.0
TOLUENE	120 U				120 U		130 U	0.0
TRANS-1 3-DICHLOROPROPENE	120 U				120 U		130 U	0.0
1 1 2-TRICHLOROETHANE	120 U				120 U		130 U	0.0
TETRACHLOROETHENE	120 U				120 U		130 U	0.0
2-HEXANONE	250 U				250 U		250 U	0.0
DIBROMOCHLOROMETHANE	120 U				120 U		130 U	0.0
CHLOROBENZENE	120 U				120 U		130 U	0.0
ETHYLBENZENE	120 U				120 U		130 U	0.0
P-XYLENE/M-XYLENE	120 U				120 U		130 U	0.0
O-XYLENE	120 U				120 U		130 U	0.0
STYRENE	120 U				120 U		130 U	0.0
BROMOFORM	120 U				120 U		130 U	0.0
1 1 2 2-TETRACHLOROETHANE	120 U				120 U		130 U	0.0

**NOTES:**

U = Below Practical Quantitation Limit (PQL)

Blank = Not sampled

WELL NUMBER EW-3  
ANALYTICAL SAMPLING RESULTS  
(Concentrations in ug/L)

ANALYTE	4/15/93	7/21/93	10/14/93	1/24/94	4/94	7/19/94	10/94	1/10/95	4/95	7/95	10/95	1/29/96	4/96	7/96
CHLOROMETHANE	5 U	5 U	25 U	5 U		25 U		50 U				100 U		
VINYL CHLORIDE	28	35	113	58		66		76				150		
CHLOROETHANE	5 U	5 U	25 U	5 U		25 U		50 U				100 U		
BROMOMETHANE	5 U	5 U	25 U	5 U		25 U		50 U				100 U		
1 1-DICHLOROETHENE	5 U	5 U	25 U	5 U		25 U		50 U				100 U		
ACETONE	50 U	50 U	250 U	50 U		250 U		500 U				500 U		
CARBON DISULFIDE	5 U	5 U	279	6		25 U		50 U				100 U		
METHYLENE CHLORIDE	5 U	5 U	25 U	5 U		25 U		50 U				100 U		
TRANS-1 2-DICHLOROETHENE	5 U	5 U	25 U	5 U		25 U		50 U				100 U		
1 1-DICHLOROETHANE	5 U	5 U	25 U	5		25 U		50 U				100 U		
CIS-1 2-DICHLOROETHENE	215	208	815	270		1140		1380				2300		
METHYL ETHYL KETONE	50 U	50 U	250 U	50 U		250 U		500 U				500 U		
CHLOROFORM	5 U	5 U	25 U	5 U		25 U		50 U				100 U		
1 1 1-TRICHLOROETHANE	5 U	5 U	25 U	8		25 U		50 U				100 U		
CARBON TETRACHLORIDE	5 U	5 U	25 U	5 U		25 U		50 U				100 U		
BENZENE	5 U	5 U	25 U	5 U		25 U		50 U				100 U		
1 2-DICHLOROETHANE	5 U	5 U	25 U	5 U		25 U		50 U				100 U		
TRICHLOROETHENE	28	5 U	25 U	5 U		43		50 U				930		
1 2-DICHLOROPROPANE	5 U	5 U	25 U	5 U		25 U		50 U				100 U		
BROMODICHLOROMETHANE	5 U	5 U	25 U	5 U		25 U		50 U				100 U		
CIS-1 3-DICHLOROPROPENE	5 U	5 U	25 U	5 U		25 U		50 U				100 U		
MIBK	50 U	50 U	250 U	50 U		250 U		500 U				500 U		
TOLUENE	5 U	5 U	25 U	5 U		25 U		50 U				100 U		
TRANS-1 3-DICHLOROPROPENE	5 U	5 U	25 U	5 U		25 U		50 U				100 U		
1 1 2-TRICHLOROETHANE	5 U	5 U	25 U	5 U		25 U		50 U				100 U		
TETRACHLOROETHENE	5 U	5 U	25 U	5 U		25 U		50 U				100 U		
2-HEXANONE	50 U	50 U	250 U	50 U		250 U		500 U				500 U		
DIBROMOCHLOROMETHANE	5 U	5 U	25 U	5 U		25 U		50 U				100 U		
CHLOROBENZENE	5 U	5 U	25 U	5 U		25 U		50 U				100 U		
ETHYLBENZENE	5 U	5 U	25 U	5 U		25 U		50 U				100 U		
P-XYLENE/M-XYLENE	5 U	5 U	25 U	5 U		25 U		50 U				100 U		
O-XYLENE	5 U	5 U	25 U	5 U		25 U		50 U				100 U		
STYRENE	5 U	5 U	25 U	5 U		25 U		50 U				100 U		
BROMOFORM	5 U	5 U	25 U	5 U		25 U		50 U				100 U		
1 1 2 2-TETRACHLOROETHANE	5 U	5 U	25 U	5 U		25 U		50 U				100 U		

**NOTES:**

U = Below Practical Quantitation Limit (PQL)

Blank = Not sampled

WELL NUMBER EW-3  
ANALYTICAL SAMPLING RESULTS  
(Concentrations in ug/L)

ANALYTE	10/16/96	1/97	4/97	7/97	10/29/97	4/98	10/27/98	AVG
CHLOROMETHANE	120 U				120 U		130 U	0.0
VINYL CHLORIDE	120 U				200		480	120.6
CHLOROETHANE	120 U				120 U		130 U	0.0
BROMOMETHANE	120 U				120 U		130 U	0.0
1 1-DICHLOROETHENE	120 U				120 U		130 U	0.0
ACETONE	620 U				620 U		630 U	0.0
CARBON DISULFIDE	120 U				120 U		130 U	28.5
METHYLENE CHLORIDE	120 U				120 U		130 U	0.0
TRANS-1 2-DICHLOROETHENE	120 U				120 U		130 U	0.0
1 1-DICHLOROETHANE	120 U				120 U		130 U	0.5
CIS-1 2-DICHLOROETHENE	2800				3400		3700	1622.8
METHYL ETHYL KETONE	620 U				620 U		630 U	0.0
CHLOROFORM	120 U				120 U		130 U	0.0
1 1 1-TRICHLOROETHANE	120 U				120 U		130 U	0.8
CARBON TETRACHLORIDE	120 U				120 U		130 U	0.0
BENZENE	120 U				120 U		18 U	0.0
1 2-DICHLOROETHANE	120 U				120 U		130 U	0.0
TRICHLOROETHENE	120 U				120 U		49 J	100.1
1 2-DICHLOROPROPANE	120 U				120 U		130 U	0.0
BROMODICHLOROMETHANE	120 U				120 U		130 U	0.0
CIS-1 3-DICHLOROPROPENE	120 U				120 U		130 U	0.0
MIBK	250 U				250 U		250 U	0.0
TOLUENE	120 U				120 U		130 U	0.0
TRANS-1 3-DICHLOROPROPENE	120 U				120 U		130 U	0.0
1 1 2-TRICHLOROETHANE	120 U				120 U		130 U	0.0
TETRACHLOROETHENE	120 U				120 U		130 U	0.0
2-HEXANONE	250 U				250 U		250 U	0.0
DIBROMOCHLOROMETHANE	120 U				120 U		130 U	0.0
CHLOROBENZENE	120 U				120 U		130 U	0.0
ETHYLBENZENE	120 U				120 U		130 U	0.0
P-XYLENE/M-XYLENE	120 U				120 U		130 U	0.0
O-XYLENE	120 U				120 U		130 U	0.0
STYRENE	120 U				120 U		130 U	0.0
BROMOFORM	120 U				120 U		130 U	0.0
1 1 2 2-TETRACHLOROETHANE	120 U				120 U		130 U	0.0

**NOTES:**

U = Below Practical Quantitation Limit (PQL)

Blank = Not sampled

WELL NUMBER EW-4  
ANALYTICAL SAMPLING RESULTS  
(Concentrations in ug/L)

ANALYTE	4/15/93	7/21/93	10/14/93	1/17/94	4/94	7/19/94	10/94	1/10/95	4/95	7/95	10/95	1/29/96	4/96	7/96
CHLOROMETHANE	5 U	5 U	5 U	5 U		5 U		25 U				25 U		
VINYL CHLORIDE	16	23	67	25		34		43				60		
CHLOROETHANE	5 U	5 U	5 U	5 U		5 U		25 U				25 U		
BROMOMETHANE	5 U	5 U	5 U	5 U		5 U		25 U				25 U		
1 1-DICHLOROETHENE	5 U	5 U	5 U	5 U		5 U		25 U				25 U		
ACETONE	50 U	50 U	50 U	50 U		50 U		250 U				125 U		
CARBON DISULFIDE	5 U	5 U	5 U	5 U		5 U		25 U				25 U		
METHYLENE CHLORIDE	5 U	5 U	5 U	5 U		5 U		25 U				25 U		
TRANS-1 2-DICHLOROETHENE	5 U	5 U	5 U	5 U		5 U		25 U				25 U		
1 1-DICHLOROETHANE	5 U	5 U	5 U	5 U		5 U		25 U				25 U		
CIS-1 2-DICHLOROETHENE	121	156	654 J	173		488		628				340		
METHYL ETHYL KETONE	50 U	50 U	50 U	50 U		50 U		250 U				125 U		
CHLOROFORM	5 U	5 U	5 U	5 U		5 U		25 U				25 U		
1 1 1-TRICHLOROETHANE	5 U	5 U	5	5 U		5 U		25 U				25 U		
CARBON TETRACHLORIDE	5 U	5 U	5 U	5 U		5 U		25 U				25 U		
BENZENE	5 U	5 U	5 U	5 U		5 U		25 U				25 U		
1 2-DICHLOROETHANE	5 U	5 U	5 U	5 U		5 U		25 U				25 U		
TRICHLOROETHENE	5 U	5 U	28	5 U		21		25 U				25 U		
1 2-DICHLOROPROPANE	5 U	5 U	5 U	5 U		5 U		25 U				25 U		
BROMODICHLOROMETHANE	5 U	5 U	5 U	5 U		5 U		25 U				25 U		
CIS-1 3-DICHLOROPROPENE	5 U	5 U	5 U	5 U		5 U		25 U				25 U		
MIBK	50 U	50 U	50 U	50 U		50 U		250 U				125 U		
TOLUENE	5 U	5 U	5 U	5 U		5 U		25 U				25 U		
TRANS-1 3-DICHLOROPROPENE	5 U	5 U	5 U	5 U		5 U		25 U				25 U		
1 1 2-TRICHLOROETHANE	5 U	5 U	5 U	5 U		5 U		25 U				25 U		
TETRACHLOROETHENE	5 U	5 U	5 U	5 U		5 U		25 U				25 U		
2-HEXANONE	50 U	50 U	50 U	50 U		50 U		250 U				125 U		
DIBROMOCHLOROMETHANE	5 U	5 U	5 U	5 U		5 U		25 U				25 U		
CHLOROBENZENE	5 U	5 U	5 U	5 U		5 U		25 U				25 U		
ETHYLBENZENE	5 U	5 U	5 U	5 U		5 U		25 U				25 U		
P-XYLENE/M-XYLENE	5 U	5 U	5 U	5 U		5 U		25 U				25 U		
O-XYLENE	5 U	5 U	5 U	5 U		5 U		25 U				25 U		
STYRENE	5 U	5 U	5 U	5 U		5 U		25 U				25 U		
BROMOFORM	5 U	5 U	5 U	5 U		5 U		25 U				25 U		
1 1 2 2-TETRACHLOROETHANE	5 U	5 U	5 U	5 U		5 U		25 U				25 U		

**NOTES:**

U = Below Practical Quantitation Limit (PQL)

J = Estimated

Blank = Not sampled

WELL NUMBER EW-4  
ANALYTICAL SAMPLING RESULTS  
(Concentrations in ug/L)

ANALYTE	10/16/96	1/97	4/97	7/97	10/29/97	4/98	10/27/98	AVG
CHLOROMETHANE	25 U				25 U		1 U	0.0
VINYL CHLORIDE	38				57		29	39.2
CHLOROETHANE	25 U				25 U		1 U	0.0
BROMOMETHANE	25 U				25 U		1 U	0.0
1 1-DICHLOROETHENE	25 U				25 U		1 U	0.0
ACETONE	120 U				120 U		10 U	0.0
CARBON DISULFIDE	25 U				25 U		1 U	0.0
METHYLENE CHLORIDE	25 U				25 U		1 U	0.0
TRANS-1 2-DICHLOROETHENE	25 U				25 U		1 U	0.0
1 1-DICHLOROETHANE	25 U				25 U		1 U	0.0
CIS-1 2-DICHLOROETHENE	200				210		130	244.6
METHYL ETHYL KETONE	120 U				120 U		10 U	0.0
CHLOROFORM	25 U				25 U		1 U	0.0
1 1 1-TRICHLOROETHANE	25 U				25 U		1 U	0.5
CARBON TETRACHLORIDE	25 U				25 U		1 U	0.0
BENZENE	25 U				25 U		0.700 U	0.0
1 2-DICHLOROETHANE	25 U				25 U		1 U	0.0
TRICHLOROETHENE	25 U				25 U		11	6.0
1 2-DICHLOROPROPANE	25 U				25 U		1 U	0.0
BROMODICHLOROMETHANE	25 U				25 U		1 U	0.0
CIS-1 3-DICHLOROPROPENE	25 U				25 U		1 U	0.0
MIBK	50 U				50 U		10 U	0.0
TOLUENE	25 U				25 U		1 U	0.0
TRANS-1 3-DICHLOROPROPENE	25 U				25 U		1 U	0.0
1 1 2-TRICHLOROETHANE	25 U				25 U		1 U	0.0
TETRACHLOROETHENE	25 U				25 U		1 U	0.0
2-HEXANONE	50 U				50 U		10 U	0.0
DIBROMOCHLOROMETHANE	25 U				25 U		1 U	0.0
CHLOROBENZENE	25 U				25 U		1 U	0.0
ETHYLBENZENE	25 U				25 U		1 U	0.0
P-XYLENE/M-XYLENE	25 U				25 U		1 U	0.0
O-XYLENE	25 U				25 U		1 U	0.0
STYRENE	25 U				25 U		1 U	0.0
BROMOFORM	25 U				25 U		1 U	0.0
1 1 2 2-TETRACHLOROETHANE	25 U				25 U		1 U	0.0

**NOTES:**

U = Below Practical Quantitation Limit (PQL)

J = Estimated

Blank = Not sampled



WELL NUMBER EW-5  
ANALYTICAL SAMPLING RESULTS  
(Concentrations in ug/L)

ANALYTE	4/15/93	7/21/93	10/14/93	1/17/94	4/94	7/19/94	10/94	1/10/95	4/95	7/95	10/95	1/29/96	4/96	7/96
CHLOROMETHANE	5 U	5 U	25 U	250 U		25 U		25 U				25 U		
VINYL CHLORIDE	153	85	157	250 U		45		66				83		
CHLOROETHANE	5 U	5 U	25 U	250 U		25 U		25 U				25 U		
BROMOMETHANE	5 U	5 U	25 U	250 U		25 U		25 U				25 U		
1 1-DICHLOROETHENE	26	10	25 U	250 U		25 U		25 U				25 U		
ACETONE	50 U	50 U	250 U	2500 U		250 U		250 U				125 U		
CARBON DISULFIDE	5 U	5 U	797	250 U		25 U		25 U				25 U		
METHYLENE CHLORIDE	5 U	5 U	25 U	250 U		25 U		25 U				25 U		
TRANS-1 2-DICHLOROETHENE	7	5 U	25 U	250 U		25 U		25 U				25 U		
1 1-DICHLOROETHANE	5 U	5 U	25 U	250 U		25 U		25 U				25 U		
CIS-1 2-DICHLOROETHENE	655	315	1410	724		591		674				270		
METHYL ETHYL KETONE	50 U	50 U	250 U	2500 U		250 U		250 U				125 U		
CHLOROFORM	5 U	5 U	25 U	250 U		25 U		25 U				25 U		
1 1 1-TRICHLOROETHANE	5 U	5 U	25 U	250 U		25 U		25 U				25 U		
CARBON TETRACHLORIDE	5 U	5 U	25 U	250 U		25 U		25 U				25 U		
BENZENE	5 U	5 U	25 U	250 U		25 U		25 U				25 U		
1 2-DICHLOROETHANE	5 U	5 U	25 U	250 U		25 U		25 U				25 U		
TRICHLOROETHENE	5 U	5 U	59	250 U		25 U		25 U				25 U		
1 2-DICHLOROPROPANE	5 U	5 U	25 U	250 U		25 U		25 U				25 U		
BROMODICHLOROMETHANE	5 U	5 U	25 U	250 U		25 U		25 U				25 U		
CIS-1 3-DICHLOROPROPENE	5 U	5 U	25 U	250 U		25 U		25 U				25 U		
MIBK	50 U	50 U	250 U	2500 U		250 U		250 U				125 U		
TOLUENE	5 U	5 U	25 U	250 U		25 U		25 U				25 U		
TRANS-1 3-DICHLOROPROPENE	5 U	5 U	25 U	250 U		25 U		25 U				25 U		
1 1 2-TRICHLOROETHANE	5 U	5 U	25 U	250 U		25 U		25 U				25 U		
TETRACHLOROETHENE	5 U	5 U	25 U	250 U		25 U		25 U				25 U		
2-HEXANONE	50 U	50 U	250 U	2500 U		250 U		250 U				125 U		
DIBROMOCHLOROMETHANE	5 U	5 U	25 U	250 U		25 U		25 U				25 U		
CHLORO BENZENE	5 U	5 U	25 U	250 U		25 U		25 U				25 U		
ETHYLBENZENE	5 U	5 U	25 U	250 U		25 U		25 U				25 U		
P-XYLENE/M-XYLENE	5 U	5 U	25 U	250 U		25 U		25 U				25 U		
O-XYLENE	5 U	5 U	25 U	250 U		25 U		25 U				25 U		
STYRENE	5 U	5 U	25 U	250 U		25 U		25 U				25 U		
BROMOFORM	5 U	5 U	25 U	250 U		25 U		25 U				25 U		
1 1 2 2-TETRACHLOROETHANE	5 U	5 U	25 U	250 U		25 U		25 U				25 U		

**NOTES:**

U = Below Practical Quantitation Limit (PQL)

Blank = Not sampled

WELL NUMBER EW-5  
ANALYTICAL SAMPLING RESULTS  
(Concentrations in ug/L)

ANALYTE	10/16/96	1/97	4/97	7/97	10/29/97	4/98	10/27/98	AVG
CHLOROMETHANE	5 U				5 U		1 U	0.0
VINYL CHLORIDE	46				48		42	72.5
CHLOROETHANE	5 U				5 U		1 U	0.0
BROMOMETHANE	5 U				5 U		1 U	0.0
1 1-DICHLOROETHENE	5 U				5 U		2	3.8
ACETONE	25 U				25 U		10 U	0.0
CARBON DISULFIDE	5 U				5 U		1 U	79.7
METHYLENE CHLORIDE	5 U				5 U		1 U	0.0
TRANS-1 2-DICHLOROETHENE	5 U				5 U		1	0.8
1 1-DICHLOROETHANE	5 U				5 U		1 U	0.0
CIS-1 2-DICHLOROETHENE	120				110		83	495.2
METHYL ETHYL KETONE	73				25 U		10 U	7.3
CHLOROFORM	5 U				5 U		1 U	0.0
1 1 1-TRICHLOROETHANE	5 U				5 U		1 U	0.0
CARBON TETRACHLORIDE	5 U				5 U		1 U	0.0
BENZENE	5 U				5 U		0.700 U	0.0
1 2-DICHLOROETHANE	5 U				5 U		1 U	0.0
TRICHLOROETHENE	5 U				5 U		1	6.0
1 2-DICHLOROPROPANE	5 U				5 U		1 U	0.0
BROMODICHLOROMETHANE	5 U				5 U		1 U	0.0
CIS-1 3-DICHLOROPROPENE	5 U				5 U		1 U	0.0
MIBK	10 U				10 U		10 U	0.0
TOLUENE	5 U				5 U		1 U	0.0
TRANS-1 3-DICHLOROPROPENE	5 U				5 U		1 U	0.0
1 1 2-TRICHLOROETHANE	5 U				5 U		1 U	0.0
TETRACHLOROETHENE	5 U				5 U		1 U	0.0
2-HEXANONE	10 U				10 U		10 U	0.0
DIBROMOCHLOROMETHANE	5 U				5 U		1 U	0.0
CHLOROBENZENE	5 U				5 U		1 U	0.0
ETHYLBENZENE	5 U				5 U		1 U	0.0
P-XYLENE/M-XYLENE	5 U				5 U		1 U	0.0
O-XYLENE	5 U				5 U		1 U	0.0
STYRENE	5 U				5 U		1 U	0.0
BROMOFORM	5 U				5 U		1 U	0.0
1 1 2 2-TETRACHLOROETHANE	5 U				5 U		1 U	0.0

**NOTES:**

U = Below Practical Quantitation Limit (PQL)

Blank = Not sampled

WELL NUMBER EW-6  
ANALYTICAL SAMPLING RESULTS  
(Concentrations in ug/L)

ANALYTE	4/15/93	7/21/93	10/14/93	1/17/94	4/94	7/19/94	10/94	1/10/95	4/95	7/95	10/95	2/2/96	4/19/96	7/17/96
CHLOROMETHANE	5 U	5 U	5 U	5 U		5 U		5 U				5 U	5 U	5 U
VINYL CHLORIDE	24	24	51	24		25		32				52	34	15
CHLOROETHANE	5 U	5 U	5 U	5 U		5 U		5 U				5 U	5 U	5 U
BROMOMETHANE	5 U	5 U	5 U	5 U		5 U		5 U				5 U	5 U	5 U
1 1-DICHLOROETHENE	5 U	5 U	5 U	5 U		5 U		5 U				5 U	5 U	5 U
ACETONE	50 U	50 U	50 U	50 U		50 U		50 U				25 U	25 U	25 U
CARBON DISULFIDE	5 U	5 U	5 U	5 U		5 U		5 U				5 U	5 U	5 U
METHYLENE CHLORIDE	5 U	5 U	5 U	5 U		14J		5 U				5 U	5 U	5 U
TRANS-1 2-DICHLOROETHENE	5 U	5 U	5 U	5 U		5 U		5 U				5 U	5 U	5 U
1 1-DICHLOROETHANE	5 U	5 U	5 U	5 U		5 U		5 U				5 U	5 U	5 U
CIS-1 2-DICHLOROETHENE	119	113	508	136		204J		235				140	115	69
METHYL ETHYL KETONE	50 U	50 U	50 U	50 U		50 U		50 U				25 U	25 U	25 U
CHLOROFORM	5 U	5 U	5 U	5 U		5 U		5 U				5 U	5 U	5 U
1 1 1-TRICHLOROETHANE	5 U	5 U	5 U	5 U		5 U		5 U				5 U	5 U	5 U
CARBON TETRACHLORIDE	5 U	5 U	5 U	5 U		5 U		5 U				5 U	5 U	5 U
BENZENE	5 U	5 U	5 U	5 U		5 U		5 U				5 U	5 U	5 U
1 2-DICHLOROETHANE	5 U	5 U	5 U	5 U		5 U		5 U				5 U	5 U	5 U
TRICHLOROETHENE	5 U	5 U	6	7		5 U		5 U				5 U	12	5 U
1 2-DICHLOROPROPANE	5 U	5 U	5 U	5 U		5 U		5 U				5 U	5 U	5 U
BROMODICHLOROMETHANE	5 U	5 U	5 U	5 U		5 U		5 U				5 U	5 U	5 U
CIS-1 3-DICHLOROPROPENE	5 U	5 U	5 U	5 U		5 U		5 U				5 U	5 U	5 U
MIBK	50 U	50 U	50 U	50 U		50 U		50 U				25 U	10 U	10 U
TOLUENE	5 U	5 U	5 U	5 U		5 U		5 U				5 U	5 U	5 U
TRANS-1 3-DICHLOROPROPENE	5 U	5 U	5 U	5 U		5 U		5 U				5 U	5 U	5 U
1 1 2-TRICHLOROETHANE	5 U	5 U	5 U	5 U		5 U		5 U				5 U	5 U	5 U
TETRACHLOROETHENE	5 U	5 U	5 U	5 U		5 U		5 U				5 U	5 U	5 U
2-HEXANONE	50 U	50 U	50 U	50 U		50 U		50 U				25 U	10 U	10 U
DIBROMOCHLOROMETHANE	5 U	5 U	5 U	5 U		5 U		5 U				5 U	5 U	5 U
CHLOROBENZENE	5 U	5 U	5 U	5 U		5 U		5 U				5 U	5 U	5 U
ETHYLBENZENE	5 U	5 U	5 U	5 U		5 U		5 U				5 U	5 U	5 U
P-XYLENE/M-XYLENE	5 U	5 U	5 U	5 U		5 U		5 U				5 U	5 U	5 U
O-XYLENE	5 U	5 U	5 U	5 U		5 U		5 U				5 U	5 U	5 U
STYRENE	5 U	5 U	5 U	5 U		5 U		5 U				5 U	5 U	5 U
BROMOFORM	5 U	5 U	5 U	5 U		5 U		5 U				5 U	5 U	5 U
1 1 2 2-TETRACHLOROETHANE	5 U	5 U	5 U	5 U		5 U		5 U				5 U	5 U	5 U

NOTES:

U = Below Practical Quantitation Limit (PQL)

J = Estimated

Blank = Not sampled

WELL NUMBER EW-6  
ANALYTICAL SAMPLING RESULTS  
(Concentrations in ug/L)

ANALYTE	10/16/96	1/15/97	4/29/97	7/22/97	10/29/97	4/20/98	10/27/98	AVG
CHLOROMETHANE	5 U	5 U	0.5 U	0.5 U	0.5 U	1 U	1 U	0.0
VINYL CHLORIDE	15	48	10	10	25	11	11	25.7
CHLOROETHANE	5 U	5 U	0.5 U	0.5 U	0.5 U	1 U	1 U	0.0
BROMOMETHANE	5 U	5 U	0.5 U	0.5 U	0.5 U	1 U	1 U	0.0
1 1-DICHLOROETHENE	5 U	5 U	0.5 U	0.5 U	0.5 U	1 U	1 U	0.0
ACETONE	25 U	25 U	10 U	10 U	10 U	10 U	10 U	0.0
CARBON DISULFIDE	5 U	5 U	0.7	0.5 U	0.5 U	1	1 U	0.1
METHYLENE CHLORIDE	5 U	5 U	0.5 U	0.5 U	0.5 U	2 U	1 U	0.0
TRANS-1 2-DICHLOROETHENE	5 U	5 U	0.5 U	0.5 U	0.5 U	1 U	1 U	0.0
1 1-DICHLOROETHANE	5 U	5 U	0.5 U	0.5 U	0.5 U	1 U	1 U	0.0
CIS-1 2-DICHLOROETHENE	59	470	35	34	63	33	32	135.1
METHYL ETHYL KETONE	25 U	25 U	10 U	10 U	10 U	10 U	10 U	0.0
CHLOROFORM	5 U	5 U	0.5 U	0.5 U	0.5 U	1 U	1 U	0.0
1 1 1-TRICHLOROETHANE	5 U	6	0.5 U	0.5 U	0.5 U	1 U	1 U	0.4
CARBON TETRACHLORIDE	5 U	5 U	0.5 U	0.5 U	0.5 U	1 U	1 U	0.0
BENZENE	5 U	5 U	0.5 U	0.5 U	0.5 U	0.7 U	0.700 U	0.0
1 2-DICHLOROETHANE	5 U	5 U	0.5 U	0.5 U	0.5 U	1 U	1 U	0.0
TRICHLOROETHENE	5 U	22	0.7	0.5 U	0.5 U	1 U	1 U	3.0
1 2-DICHLOROPROPANE	5 U	5 U	0.5 U	0.5 U	0.5 U	1 U	1 U	0.0
BROMODICHLOROMETHANE	5 U	5 U	0.5 U	0.5 U	0.5 U	1 U	1 U	0.0
CIS-1 3-DICHLOROPROPENE	5 U	5 U	0.5 U	0.5 U	0.5 U	1 U	1 U	0.0
MIBK	10 U	10 U	10 U	10 U	10 U	10 U	10 U	0.0
TOLUENE	5 U	5 U	0.5 U	0.5 U	0.5 U	1 U	1 U	0.0
TRANS-1 3-DICHLOROPROPENE	5 U	5 U	0.5 U	0.5 U	0.5 U	1 U	1 U	0.0
1 1 2-TRICHLOROETHANE	5 U	5 U	0.5 U	0.5 U	0.5 U	1 U	1 U	0.0
TETRACHLOROETHENE	5 U	5 U	0.5 U	0.5 U	0.5 U	1 U	1 U	0.0
2-HEXANONE	10 U	10 U	10 U	10 U	10 U	10 U	10 U	0.0
DIBROMOCHLOROMETHANE	5 U	5 U	0.5 U	0.5 U	0.5 U	1 U	1 U	0.0
CHLOROBENZENE	5 U	5 U	0.5 U	0.5 U	0.5 U	1 U	1 U	0.0
ETHYLBENZENE	5 U	5 U	0.5 U	0.5 U	0.5 U	1 U	1 U	0.0
P-XYLENE/M-XYLENE	5 U	5 U	0.5 U	0.5 U	0.5 U	1 U	1 U	0.0
O-XYLENE	5 U	5 U	0.5 U	0.5 U	0.5 U	1 U	1 U	0.0
STYRENE	5 U	5 U	0.5 U	0.5 U	0.5 U	1 U	1 U	0.0
BROMOFORM	5 U	5 U	0.5 U	0.5 U	0.5 U	1 U	1 U	0.0
1 1 2 2-TETRACHLOROETHANE	5 U	5 U	0.5 U	0.5 U	0.5 U	1 U	1 U	0.0

**NOTES:**

U = Below Practical Quantitation Limit (PQL)

J = Estimated

Blank = Not sampled

WELL NUMBER EW-7  
ANALYTICAL SAMPLING RESULTS  
(Concentrations in ug/L)

ANALYTE	4/93	7/93	10/93	1/94	4/26/94	7/21/94	11/2/94	1/13/95	4/19/95	7/13/95	10/18/95	1/31/96	4/18/96
CHLOROMETHANE					50 U	50 U	50 U	100 U	100 U	100 U	125 U	250 U	250 U
VINYL CHLORIDE					76	446	437	403	453	690	990	990	590
CHLOROETHANE					50 U	50 U	50 U	100 U	100 U	100 U	125 U	250 U	250 U
BROMOMETHANE					50 U	50 U	50 U	100 U	100 U	100 U	125 U	250 U	250 U
1 1-DICHLOROETHENE					50 U	50 U	50 U	100 U	100 U	100 U	125 U	250 U	250 U
ACETONE					500 U	500 U	500 U	1000 U	1000 U	1000 U	1250 U	1250 U	1250 U
CARBON DISULFIDE					50 U	50 U	50 U	100 U	100 U	100 U	125 U	250 U	250 U
METHYLENE CHLORIDE					50 U	50 U	50 U	100 U	100 U	100 U	125 U	250 U	250 U
TRANS-1 2-DICHLOROETHENE					50 U	50 U	50 U	100 U	100 U	100 U	125 U	250 U	250 U
1 1-DICHLOROETHANE					50 U	50 U	50 U	100 U	100 U	100 U	125 U	250 U	250 U
CIS-1 2-DICHLOROETHENE					860	4990	2720	2020	2680	7610	5500	8100	4800
METHYL ETHYL KETONE					500 U	500 U	500 U	1000 U	1000 U	1000 U	1250 U	1250 U	1250 U
CHLOROFORM					50 U	50 U	50 U	100 U	100 U	100 U	125 U	250 U	250 U
1 1 1-TRICHLOROETHANE					50 U	50 U	88	100 U	100 U	106	125 U	250 U	250 U
CARBON TETRACHLORIDE					50 U	50 U	50 U	100 U	100 U	100 U	125 U	250 U	250 U
BENZENE					50 U	50 U	50 U	100 U	100 U	100 U	125 U	250 U	250 U
1 2-DICHLOROETHANE					50 U	50 U	50 U	100 U	100 U	100 U	125 U	250 U	250 U
TRICHLOROETHENE					50 U	50 U	63	106	100 U	1140	502	560	320
1 2-DICHLOROPROPANE					50 U	50 U	50 U	100 U	100 U	100 U	125 U	250 U	250 U
BROMODICHLOROMETHANE					50 U	50 U	50 U	100 U	100 U	100 U	125 U	250 U	250 U
CIS-1 3-DICHLOROPROPENE					50 U	50 U	50 U	100 U	100 U	100 U	125 U	250 U	250 U
MIBK					500 U	500 U	500 U	1000 U	1000 U	1000 U	1250 U	1250 U	500 U
TOLUENE					50 U	50 U	50 U	100 U	100 U	100 U	125 U	250 U	250 U
TRANS-1 3-DICHLOROPROPENE					50 U	50 U	50 U	100 U	100 U	100 U	125 U	250 U	250 U
1 1 2-TRICHLOROETHANE					50 U	50 U	50 U	100 U	100 U	100 U	125 U	250 U	250 U
TETRACHLOROETHENE					50 U	50 U	50 U	100 U	100 U	100 U	125 U	250 U	250 U
2-HEXANONE					500 U	500 U	500 U	1000 U	1000 U	1000 U	1250 U	1250 U	500 U
DIBROMOCHLOROMETHANE					50 U	50 U	50 U	100 U	100 U	100 U	125 U	250 U	250 U
CHLOROBENZENE					50 U	50 U	50 U	100 U	100 U	100 U	125 U	250 U	250 U
ETHYLBENZENE					50 U	50 U	50 U	100 U	100 U	100 U	125 U	250 U	250 U
P-XYLENE/M-XYLENE					50 U	50 U	50 U	100 U	100 U	100 U	125 U	250 U	250 U
O-XYLENE					50 U	50 U	50 U	100 U	100 U	100 U	125 U	250 U	250 U
STYRENE					50 U	50 U	50 U	100 U	100 U	100 U	125 U	250 U	250 U
BROMOFORM					50 U	50 U	50 U	100 U	100 U	100 U	125 U	250 U	250 U
1 1 2 2-TETRACHLOROETHANE					50 U	50 U	50 U	100 U	100 U	100 U	125 U	250 U	250 U

**NOTES:**

U = Below Practical Quantitation Limit (PQL)

Blank = Not sampled

WELL NUMBER EW-7  
ANALYTICAL SAMPLING RESULTS  
(Concentrations in ug/L)

ANALYTE	7/17/96	10/18/96	1/15/97	4/29/97	7/22/97	10/30/97	4/20/98	10/29/98	AVG
CHLOROMETHANE	250 U	250 U	250 U	250 U	25 U	250 U	50 U	250 U	0.0
VINYL CHLORIDE	510	520	520	680	600	650	500	3600	744.4
CHLOROETHANE	250 U	250 U	250 U	250 U	25 U	250 U	50 U	250 U	0.0
BROMOMETHANE	250 U	250 U	250 U	250 U	25 U	250 U	50 U	250 U	0.0
1 1-DICHLOROETHENE	250 U	250 U	250 U	250 U	25 U	250 U	50 U	250 U	0.0
ACETONE	1250 U	1200 U	1200 U	1200 U	500 U	1200 U	500 U	1300 U	0.0
CARBON DISULFIDE	250 U	250 U	250 U	250 U	25 U	250 U	50 U	250 U	0.0
METHYLENE CHLORIDE	250 U	250 U	250 U	250 U	68	250 U	100 U	250 U	4.0
TRANS-1 2-DICHLOROETHENE	250 U	250 U	250 U	250 U	25 U	250 U	50 U	250 U	0.0
1 1-DICHLOROETHANE	250 U	250 U	250 U	250 U	25	250 U	50 U	250 U	1.5
CIS-1 2-DICHLOROETHENE	6700	5200	4700	4900	4500	4300	2800	2700	4416.5
METHYL ETHYL KETONE	1250 U	1200 U	1200 U	1200 U	500 U	1200 U	500 U	1300 U	0.0
CHLOROFORM	250 U	250 U	250 U	250 U	25 U	250 U	50 U	250 U	0.0
1 1 1-TRICHLOROETHANE	250 U	250 U	250 U	250 U	51	250 U	50 U	250 U	14.4
CARBON TETRACHLORIDE	250 U	250 U	250 U	250 U	25 U	250 U	50 U	250 U	0.0
BENZENE	250 U	250 U	250 U	250 U	25 U	250 U	35 U	250 U	0.0
1 2-DICHLOROETHANE	250 U	250 U	250 U	250 U	25 U	250 U	50 U	250 U	0.0
TRICHLOROETHENE	870	250 U	250 U	250 U	150	250 U	88	250 U	223.5
1 2-DICHLOROPROPANE	250 U	250 U	250 U	250 U	25 U	250 U	50 U	250 U	0.0
BROMODICHLOROMETHANE	250 U	250 U	250 U	250 U	25 U	250 U	50 U	250 U	0.0
CIS-1 3-DICHLOROPROPENE	250 U	250 U	250 U	250 U	25 U	250 U	50 U	250 U	0.0
MIBK	500 U	500 U	500 U	500 U	500 U	500 U	500 U	500 U	0.0
TOLUENE	250 U	250 U	250 U	250 U	25 U	250 U	50 U	250 U	0.0
TRANS-1 3-DICHLOROPROPENE	250 U	250 U	250 U	250 U	25 U	250 U	50 U	250 U	0.0
1 1 2-TRICHLOROETHANE	250 U	250 U	250 U	250 U	25 U	250 U	50 U	250 U	0.0
TETRACHLOROETHENE	250 U	250 U	250 U	250 U	25 U	250 U	50 U	250 U	0.0
2-HEXANONE	500 U	500 U	500 U	500 U	500 U	500 U	500 U	500 U	0.0
DIBROMOCHLOROMETHANE	250 U	250 U	250 U	250 U	25 U	250 U	50 U	250 U	0.0
CHLOROBENZENE	250 U	250 U	250 U	250 U	25 U	250 U	50 U	250 U	0.0
ETHYLBENZENE	250 U	250 U	250 U	250 U	25 U	250 U	50 U	250 U	0.0
P-XYLENE/M-XYLENE	250 U	250 U	250 U	250 U	25 U	250 U	50 U	250 U	0.0
O-XYLENE	250 U	250 U	250 U	250 U	25 U	250 U	50 U	250 U	0.0
STYRENE	250 U	250 U	250 U	250 U	25 U	250 U	50 U	250 U	0.0
BROMOFORM	250 U	250 U	250 U	250 U	25 U	250 U	50 U	250 U	0.0
1 1 2 2-TETRACHLOROETHANE	250 U	250 U	250 U	250 U	25 U	250 U	50 U	250 U	0.0

**NOTES:**

U = Below Practical Quantitation Limit (PQL)

Blank = Not sampled

WELL NUMBER EW-8  
ANALYTICAL SAMPLING RESULTS  
(Concentrations in ug/L)

ANALYTE	4/93	7/93	10/93	1/94	4/26/94	7/21/94	11/2/94	1/9/95	4/19/95	7/13/95	10/18/95	1/31/96	4/18/96
CHLOROMETHANE					5 U	5 U	5 U	50 U	500 U	500 U	50 U	25 U	250 U
VINYL CHLORIDE					5 U	12	19	147	500 U	500 U	50 U	460	250 U
CHLOROETHANE					5 U	5 U	5 U	50 U	500 U	500 U	50 U	25 U	250 U
BROMOMETHANE					5 U	5 U	5 U	50 U	500 U	500 U	50 U	25 U	250 U
1 1-DICHLOROETHENE					5 U	5 U	5 U	50 U	500 U	500 U	50 U	26	250 U
ACETONE					50 U	50 U	50 U	500 U	5000 U	5000 U	500 U	125 U	1250 U
CARBON DISULFIDE					5 U	5 U	5 U	50 U	500 U	500 U	50 U	25 U	250 U
METHYLENE CHLORIDE					5 U	5 U	120	2170	500 U	500 U	50 U	25 U	250 U
TRANS-1 2-DICHLOROETHENE					5 U	5 U	5 U	50 U	500 U	500 U	50 U	120	250 U
1 1-DICHLOROETHANE					5 U	6	6	50 U	500 U	500 U	50 U	34	250 U
CIS-1 2-DICHLOROETHENE					5 U	1330	452	8540	8670	5900	620	7900	2200
METHYL ETHYL KETONE					50 U	50 U	50 U	500 U	5000 U	5000 U	500 U	125 U	1250 U
CHLOROFORM					5 U	5 U	5 U	50 U	500 U	500 U	50 U	25 U	250 U
1 1 1-TRICHLOROETHANE					5 U	5 U	48	248	500 U	500 U	50 U	180	250 U
CARBON TETRACHLORIDE					5 U	5 U	5 U	50 U	500 U	500 U	50 U	25 U	250 U
BENZENE					5 U	5 U	5 U	50 U	500 U	500 U	50 U	25 U	250 U
1 2-DICHLOROETHANE					5 U	5 U	5 U	50 U	500 U	500 U	50 U	25 U	250 U
TRICHLOROETHENE					5 U	778	302	3260	5470	3780	55	2200	2300
1 2-DICHLOROPROPANE					5 U	5 U	5 U	50 U	500 U	500 U	50 U	25 U	250 U
BROMODICHLOROMETHANE					5 U	5 U	5 U	50 U	500 U	500 U	50 U	25 U	250 U
CIS-1 3-DICHLOROPROPENE					5 U	5 U	5 U	50 U	500 U	500 U	50 U	25 U	250 U
MIBK					50 U	50 U	50 U	500 U	5000 U	5000 U	500 U	125 U	500 U
TOLUENE					5 U	5 U	6	50 U	535	500 U	50 U	25 U	250 U
TRANS-1 3-DICHLOROPROPENE					5 U	5 U	5 U	50 U	500 U	500 U	50 U	25 U	250 U
1 1 2-TRICHLOROETHANE					5 U	5 U	5 U	50 U	500 U	500 U	50 U	25 U	250 U
TETRACHLOROETHENE					5 U	5 U	5 U	50 U	500 U	500 U	50 U	25 U	250 U
2-HEXANONE					50 U	50 U	50 U	500 U	5000 U	5000 U	500 U	125 U	500 U
DIBROMOCHLOROMETHANE					5 U	5 U	5 U	50 U	500 U	500 U	50 U	25 U	250 U
CHLOROBENZENE					5 U	5 U	5 U	50 U	500 U	500 U	50 U	25 U	250 U
ETHYLBENZENE					5 U	5 U	5 U	50 U	500 U	500 U	50 U	25 U	250 U
P-XYLENE/M-XYLENE					5 U	5 U	5 U	50 U	500 U	500 U	50 U	25 U	250 U
O-XYLENE					5 U	5 U	5 U	50 U	500 U	500 U	50 U	25 U	250 U
STYRENE					5 U	5 U	5 U	50 U	500 U	500 U	50 U	25 U	250 U
BROMOFORM					5 U	5 U	5 U	50 U	500 U	500 U	50 U	25 U	250 U
1 1 2 2-TETRACHLOROETHANE					5 U	5 U	5 U	50 U	500 U	500 U	50 U	25 U	250 U

**NOTES:**

U = Below Practical Quantitation Limit (PQL)

B = Analyte detected in method or trip blank

Blank = Not sampled

WELL NUMBER EW-8  
ANALYTICAL SAMPLING RESULTS  
(Concentrations in ug/L)

ANALYTE	7/17/96	10/18/96	1/15/97	4/29/97	7/22/97	10/30/97	4/20/98	10/29/98	AVG
CHLOROMETHANE	125 U	120 U	120 U	120 U	12 U	250 U	50 U	250 U	0.0
VINYL CHLORIDE	130	160	160	190	150	250 U	110	210 J	90.5
CHLOROETHANE	125 U	120 U	120 U	120 U	12 U	250 U	50 U	250 U	0.0
BROMOMETHANE	125 U	120 U	120 U	120 U	12 U	250 U	50 U	250 U	0.0
1 1-DICHLOROETHENE	125 U	120 U	120 U	120 U	12 U	250 U	50 U	250 U	1.5
ACETONE	625 U	620 U	620 U	620 U	250 U	1200 U	500 U	1300 U	0.0
CARBON DISULFIDE	125 U	120 U	120 U	120 U	12 U	250 U	50 U	250 U	0.0
METHYLENE CHLORIDE	125 U	120 U	120 U	120 U	28	250 U	100 U	250 U	136.4
TRANS-1 2-DICHLOROETHENE	125 U	120 U	120 U	120 U	12 U	250 U	50 U	250 U	7.1
1 1-DICHLOROETHANE	125 U	120 U	120 U	120 U	16	250 U	50 U	250 U	3.6
CIS-1 2-DICHLOROETHENE	2900	2000	3200	2900	4100	3300	1300	2500	3400.7
METHYL ETHYL KETONE	640	620 U	620 U	620 U	250 U	1200 U	500 U	1300 U	37.6
CHLOROFORM	125 U	120 U	120 U	120 U	12 U	250 U	50 U	250 U	0.0
1 1 1-TRICHLOROETHANE	125 U	120 U	120 U	130 B	50	250 U	50 U	250 U	30.9
CARBON TETRACHLORIDE	125 U	120 U	120 U	120 U	12 U	250 U	50 U	250 U	0.0
BENZENE	125 U	120 U	120 U	120 U	12 U	250 U	35 U	250 U	0.0
1 2-DICHLOROETHANE	125 U	120 U	120 U	120 U	12 U	250 U	50 U	250 U	0.0
TRICHLOROETHENE	1400	950	2600	1300	2400	370	430	690	1663.8
1 2-DICHLOROPROPANE	125 U	120 U	120 U	120 U	12 U	250 U	50 U	250 U	0.0
BROMODICHLOROMETHANE	125 U	120 U	120 U	120 U	12 U	250 U	50 U	250 U	0.0
CIS-1 3-DICHLOROPROPENE	125 U	120 U	120 U	120 U	12 U	250 U	50 U	250 U	0.0
MIBK	250 U	250 U	250 U	250 U	250 U	500 U	500 U	500 U	0.0
TOLUENE	125 U	120 U	120 U	120 U	12 U	250 U	50 U	250 U	31.8
TRANS-1 3-DICHLOROPROPENE	125 U	120 U	120 U	120 U	12 U	250 U	50 U	250 U	0.0
1 1 2-TRICHLOROETHANE	125 U	120 U	120 U	120 U	12 U	250 U	50 U	250 U	0.0
TETRACHLOROETHENE	125 U	120 U	120 U	120 U	12 U	250 U	50 U	250 U	0.0
2-HEXANONE	250 U	250 U	250 U	250 U	250 U	500 U	500 U	500 U	0.0
DIBROMOCHLOROMETHANE	125 U	120 U	120 U	120 U	12 U	250 U	50 U	250 U	0.0
CHLOROBENZENE	125 U	120 U	120 U	120 U	12 U	250 U	50 U	250 U	0.0
ETHYLBENZENE	125 U	120 U	120 U	320 B	12 U	250 U	50 U	250 U	0.0
P-XYLENE/M-XYLENE	125 U	120 U	120 U	990	12 U	250 U	50 U	250 U	58.2
O-XYLENE	125 U	120 U	120 U	220	12 U	250 U	50 U	250 U	12.9
STYRENE	125 U	120 U	120 U	120 U	12 U	250 U	50 U	250 U	0.0
BROMOFORM	125 U	120 U	120 U	120 U	12 U	250 U	50 U	250 U	0.0
1 1 2 2-TETRACHLOROETHANE	125 U	120 U	120 U	120 U	25 U	250 U	50 U	250 U	0.0

**NOTES:**

U = Below Practical Quantitation Limit (PQL)

B = Analyte detected in method or trip blank

Blank = Not sampled