



Periodic Review Report 2024

**Courtlandt Corners II
875 Melrose Avenue
Bronx, NY**

May 2024

Prepared for:

**Courtlandt Corners II Associates, L.P.
902 Broadway, 13th Floor
New York, NY 10010-6033**

Prepared by:

**CA RICH Geology Services, D.P.C.
17 Dupont Street
Plainview, NY 11803-1614**



May 20, 2024

Uploaded via State FTS

NYS Dept. of Environmental Conservation
Region 2 Office
Division of Environmental Remediation
47-40 21st Street
Long Island City NY 11101

Attn: Marlen Salazar, Project Manager

Re: Periodic Review Report 2024
Courtlandt Corners II
875 Melrose Avenue
Bronx, NY

Dear Marlen:

Enclosed please find the Periodic Review Report for 2024 for the above-referenced location prepared by CA RICH Geology Services, D.P.C. If you have any questions pertaining to this report, please feel free to contact the undersigned.

Sincerely,

CA RICH Geology Services, D.P.C.

Jason T. Cooper, PG
Vice President

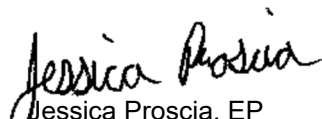
Jessica Proscia, EP
Senior Project Manager

cc: Michael Wadman, Courtlandt Corners II Associates, L.P.

Table of Contents

<u>Section</u>	<u>Page</u>
EXECUTIVE SUMMARY	
1.0 INTRODUCTION	2
1.1 Site Description	
1.2 Current Site Usage	
2.0 SITE HISTORY	2
3.0 SUMMARY OF REMEDIAL ACTION	4
4.0 EVALUATION OF REMEDY PERFORMANCE, EFFECTIVENESS, AND PROTECTIVENESS	5
4.1 Site-wide Inspection	
4.2 Engineering Controls	
5.0 INSTITUTIONAL AND ENGINEERING CONTROL (I&EC) PLAN COMPLIANCE REPORT	8
5.1 Institutional Controls	
5.2 Engineering Controls	
5.3 Certification	
6.0 MONITORING PLAN COMPLIANCE REPORT	10
6.1 Groundwater Monitoring Well Installation	
6.2 Groundwater Monitoring Well Development	
6.3 Groundwater Monitoring Well Survey	
6.4 Groundwater Monitoring Well Sampling Termination and Well Abandonment	
7.0 OPERATION & MAINTENANCE PLAN COMPLIANCE REPORT	11
7.1 Sub-slab Depressurization System	
8.0 CONCLUSIONS AND RECOMMENDATIONS	12
9.0 REFERENCES	13

FIGURES

1	Property Location Map
2	Site Plan
3	Groundwater Elevation Contour Map – April 16, 2012
4	Pilot Test Results for Vent D April 6, 2011 with Blower HP2190
5	Pilot Test Results for Vent D April 6, 2011 with Blower HP220
6	Startup Results for Vent D February 8, 2012
7	Site Survey With Schematic of SSD
8	Riser Details

APPENDICES

- A Selected Photographs
- B Site-Wide Inspection Form
- C IC/EC Form
- D Boring Logs and Well Construction Diagrams
- E O&M Checklist & Groundwater Sampling Field Forms
- F Photohelic® Details and Red Light
- G Fantech™ Model HP 220 Specifications
- H Mitigation System Installation Record
- I Environmental Easement

EXECUTIVE SUMMARY

The following Periodic Review Report has been prepared by CA RICH Geology Services, D.P.C. Inc. on behalf of Courtlandt Corners II Associates, L.P. for the Courtlandt Corners II property located at 875 Melrose Avenue in the Bronx, New York (hereinafter referred to as "Site"). This document was prepared in accordance with the Site Management Plan dated September 2010 under Brownfield Cleanup Program (BCP) Agreement, Index Number A2-0593-07-07; Site #C203041.

The Courtlandt Corners II Site is identified as Block: 2408; Lot: 20 on the Bronx Borough Tax Map. Under the redevelopment plan the Site was reclassified as a single lot (Block: 2408; Lot: 1), a portion of which is the former Lot 20. The Site is comprised of 0.16 acres of land bounded by East 162nd Street to the north, East 161st Street to the south, Melrose Avenue to the east, and Courtlandt Avenue to the west. The Site is located in an area consisting of mixed residential and commercial use. The Site was historically utilized as a filling station and residential dwellings between 1891 and 1989. A United States Geological Survey (USGS) topographical quadrangle map illustrating the Site location is enclosed as Figure 1. A Site Plan is enclosed as Figure 2.

Courtlandt Corners II was redeveloped into an affordable housing complex with commercial space on the first floor. The Site consists of 255 units of affordable renting housing, approximately 18,000 square feet of commercial space located on the ground floors on East 161st Street, and an approximately 20,000 square foot below grade parking garage. Redevelopment activities occurred from 2009 to 2012.

A Remedial Investigation (RI) was conducted at the Site in 2008 (Ref. 4). The RI identified five areas of concern: petroleum contaminated soil, petroleum contaminated groundwater, urban fill, underground storage tanks, and soil vapor. Remedial work on the Site began in November 2008, and was completed in July 2009. The Final Engineering Report (FER) dated October 2010 (Ref. 6) documents the results of the remedial action after its completion. After completion of the remedial work described in the Remedial Action Work Plan (Ref. 5), some residual soil and groundwater contamination was left in the subsurface at the Site. The Site Management Plan (SMP) was prepared to manage the residual contamination at the Site in perpetuity or until extinguishment of the Environmental Easement in accordance with 6 NYCRR Part 375. NYSDEC issued a Certificate of Completion in October 2010 after approving the FER and SMP. All reports associated with the Site can be viewed by contacting the NYSDEC or its successor agency managing environmental issues in New York State.

1.0 INTRODUCTION

The following Periodic Review Report has been prepared by CA RICH Geology Services, D.P.C. (CA RICH) on behalf of Courtlandt Corners II Associates, L.P. for the Courtlandt Corners II property located at 875 Melrose Avenue in the Bronx, New York (hereinafter referred to as the "Site") (see Figure 1). This document was prepared in accordance with the Site Management Plan dated September 2010; Revised June 2013 (Ref. 1) under Brownfield Cleanup Program (BCP) Agreement, Index Number A2-0593-07-07; Site #C203041. An SMP (text only) that has undergone additional revisions to include the termination of groundwater sampling activities was submitted in 2019 for review. As of the date of this PRR we have not received a response.

1.1 Site Description

The Courtlandt Corners II Site is located at 875 Melrose Avenue in the County of Bronx, New York. The Brownfield Site was identified as Block: 2408; Lot: 20 on the New York City Tax Map. Under the redevelopment plan, the redevelopment Site was reclassified into one lot. The redevelopment Site is now identified as Block: 2408 and Lot: 1; of which a portion is the former Lot 20 (located on southeast portion of the Site). The Site Plan (Figure 2) depicts the Courtlandt Corners II Site boundary and Brownfield Site boundary.

The redevelopment Site is situated on approximately 0.16 acres bounded by East 162nd Street to the north, East 161st Street to the south, Melrose Avenue to the east, and Courtlandt Avenue to the west. The Site is located in a mixed-use residential and commercial area. A United States Geological Survey (USGS) topographical quadrangle map illustrating the Site location is enclosed as Figure 1.

1.2 Current Site Usage

Courtlandt Corners II was redeveloped into an affordable housing complex with commercial space on the first floor. The Site consists of 255 units of affordable rental housing, approximately 18,000 square feet of commercial space located on the ground floors on East 161st Street, and an approximately 20,000 square foot below grade parking garage. Redevelopment activities occurred from 2009 to 2012.

2.0 SITE HISTORY

A Phase I Environmental Site Assessment (ESA) was conducted in May 2006 by AKRF, Inc (Ref. 2). The Phase I revealed that the Site was occupied by residential dwellings and a filling station between 1891 and 1989. In addition, the Phase I identified the following potential environmental concerns for the Site:

- Block: 2408; Lot: 20 is listed in the NY SPILLS database as a gasoline filling station with one active tank failure and two closed spills.
- The surrounding land uses include gasoline filling stations, automobile repair shops, parking lots, industrial manufacturing and storage facilities and a dry cleaner. The surrounding land uses have the potential to affect the soil and groundwater at the Site.

Based on the results of the Phase I, a Phase II ESA (Ref. 3) that included soil and groundwater testing was conducted in May 2007 by Fleming-Lee Shue, Inc. The Phase II testing indicated that the soil contained elevated levels of petroleum-related Volatile Organic Compounds (VOCs), Semi-Volatile Organic Compounds (SVOCs), pesticides, and heavy metals while the groundwater contained elevated levels of petroleum-related VOCs, SVOCs, lead, magnesium, manganese, and sodium.

A Remedial Investigation (RI) was conducted at the Site in 2008 by ERM (Ref. 4). The RI included the review of previous environmental reports prepared in association with NYSDEC spill number 94-01207, drilling of soil borings, and sampling of previously installed monitoring wells. Based on the RI findings, five areas of concern (AOCs) were identified:

- Petroleum Contaminated Soil - gasoline constituents exceeding Part 375 Unrestricted Use Soil Cleanup Objectives (UUSCOs) (Ref. 7) were identified in the soil down to 19 feet below grade. The presence of these compounds was related to NYSDEC Spill #94-01207.
- Petroleum Contaminated Groundwater – The RI identified the presence of light non-aqueous phase liquid (LNAPL) at two wells located on the sidewalk along East 161st Street. In addition, petroleum-related compounds were detected in the groundwater above NYSDEC TOGs groundwater standards (Ref. 8). The presence of these compounds was related to NYSDEC Spill #94-01207.

- Urban Fill - Concentrations of pesticides and the heavy metals lead, mercury, and zinc were detected above UUSCOs from zero to two feet below grade. The concentrations of these compounds were believed to be related to the historical fill observed at these depths.
- Underground Storage Tanks – Two 4,000-gallon underground storage tanks (USTs) associated with the former gasoline filling station were identified at the Site.
- Soil Vapor – Twenty-six VOCs were detected in the soil vapor. One chlorinated solvent known as tetrachloroethene was identified at levels ranging from non-detect to 13.29 ug/m³. The other VOCs detected were petroleum-related and were believed to be associated with NYSDEC Spill #94-01207.

3.0 SUMMARY OF REMEDIAL ACTION

The overall objective of the remedial action was to remediate environmental conditions at the Site to the satisfaction of the NYSDEC and NYSDOH for its intended future residential and commercial use. The following is a summary of the remedy that was implemented at the Site.

1. All soil and fill within the boundaries of the Site that exceeded Track 4 Soil Cleanup Objectives (SCOs) was excavated. Soils exceeding criteria below the water table were removed via the use of sheeting/shoring and dewatering. A total of 9,465 tons of soil and 282 tons of concrete, rock, and construction and demolition debris were transported off-site for disposal from the Site.
2. Two 4,000-gallon USTs were removed from the Site.
3. Groundwater from dewatering operations was treated on-site as necessary prior to discharge to the New York City combined sewer. The discharge of treated groundwater was conducted under a New York City Department of Environmental Protection (NYCDEP) dewatering permit and included granular activated carbon filtration for VOCs.
4. Residual groundwater contamination was treated in-situ via the addition of a calcium peroxide compound to the dewatered portions of the affected aquifer to address potential recontamination from groundwater migration following completion of dewatering.
5. All soil, fill, fluids and other material removed from the Site was transported and disposed of in accordance with all Federal, State and local laws and requirements. All exported

material was properly characterized, and taken to facilities licensed to accept this material in full compliance with all Federal, State, and local laws.

6. End-point samples were collected and analyzed to evaluate the performance of the remedy with respect to attainment of UUSCOS.
7. A vapor barrier and a sub-slab depressurization system were installed in all building areas to prevent vapor intrusion from residually contaminated groundwater and soil.
8. Ninety-nine cubic yards of gravel were imported to the Site. All imported soil/fill met 6 NYCRR Part 375-6 UUSCOs.
9. A composite cover system consisting of soil cover on open areas; soil cover and asphalt or concrete pavement on walkways, roads, parking lots, and concrete building slabs, covers the entire Site. The soil cover layer is two feet thick and consists of clean soil that meets 6NYCRR Part 375-6 UUSCOs. Slabs and paving systems (building slabs, roadways, walkways, parking lots, etc.) are at least 4-inches thick.
10. The recording of an Environmental Easement, including Institutional Controls, was required to prevent future exposure to any residual contamination remaining at the Site.
11. Publication of a Site Management Plan (SMP) for long term management of residual contamination as required by the Environmental Easement, including plans for (1) Institutional and Engineering Controls, (2) monitoring, (3) operation and maintenance and (4) reporting;
12. Periodic certification of the institutional and engineering controls listed above.
13. All responsibilities associated with the Remedial Action, including permitting requirements and pretreatment requirements, were addressed in accordance with all applicable Federal, State and local rules and regulations.

The remedial action was conducted in accordance with the approved Remedial Action Work Plan (RAWP) (Ref. 5). The Final Engineering Report (FER) prepared by ERM dated October 2010 (Ref. 6) documents the results of the remedial action after its completion. The SMP (Ref. 1) provides a detailed description of the procedures required to manage residual contamination left in place at the Site. NYSDEC issued a Certificate of Completion in October 2010 after approving the FER and SMP.

4.0 EVALUATION OF REMEDY PERFORMANCE, EFFECTIVENESS, AND PROTECTIVENESS

The SMP requires inspections of all systems installed at the Site at least annually. In addition, a comprehensive Site-wide inspection is required to be completed annually. Additional inspections in the event of an emergency, such as a natural disaster are also required. The information gathered during the inspection is reported in the following sections.

4.1 Site-wide Inspection

A site-wide inspection was conducted on April 26, 2024 by Jason Cooper, New York State Professional Geologist (NYSPG) of CA RICH. Mr. Willie Flete, the Site superintendent, provided access and accompanied Jason Cooper during the site-wide inspection. The affordable housing apartment building complex comprises the entire Site.

No additional site-wide inspections were conducted during the reporting period as there were no emergencies. The SSD system was found to be operating properly and no repairs were needed during the site inspection conducted on April 26, 2024. Select photographs of the Site during the inspection are enclosed as Appendix A. The site-wide inspection forms are enclosed in Appendix B.

4.2 Engineering Controls

Engineering controls (ECs) at the Site consist of a vapor barrier, a composite cover system and an SSD system. The engineering controls were inspected and evaluated on April 26, 2024 by Jason Cooper, NYSPG. Based on the inspection, the ECs continue to perform as designed and be protective of human health and environment. The inspection forms are enclosed in Appendix B. Details regarding the engineering controls and their inspection are outlined below.

4.2.1 Vapor Barrier

A 15-mil ASTM E-1745 compliant vapor barrier manufactured by Stego Industries, LLC was installed underneath the building's foundation. The vapor barrier was overlapped by a minimum of six inches and secured with mastic or asphaltic tape. Conduits penetrating the vapor barrier were sealed with mastic. The vapor barrier specifications were included in the Final Engineering Report.

No activities that could comprise the integrity of the vapor barrier or penetrate the vapor barrier have been conducted at the site. Our inspection conducted on April 26, 2024 concluded, based on visual observations, that the concrete basement floor has remained intact with no modifications.

4.2.2 Composite Cover System

For any residual contamination left in place, exposure to residual contaminated soils is prevented by an engineered, composite cover system that was built on the Site. The composite cover system consists of concrete pavement on walkways and building foundation slabs, and covers the majority of the Site. A small interior section of the Site is a garden area that is covered in over ten feet of clean backfill. Concrete slabs and paving systems (building slabs, roadways, walkways) are at least 12-inches thick. The composite cover system specifications are documented in the Site Management Plan.

The Site inspection included a visual inspection of the composite cover system to determine if it was intact and free from damage that might render it unsuitable for its intended purpose. During the inspection conducted on April 26, 2024, Jason Cooper did not identify any areas where the cover system appeared impaired, compromised, or otherwise damaged.

4.2.3 Sub-slab Depressurization System

A Sub-slab Depressurization System (SSDS) was installed at the Site. The SSDS is comprised of sub-slab suction pits connected to a six-inch vertical riser that extends up to the roof. The sub-slab portion of the SSDS was installed in 2010. The above grade portions of the SSDS were installed during construction of the building (approximately 2010 to 2012). In addition, a Photohelic gauge with adjustable high and low set points was installed on the riser of the SSD piping in the basement in April 2013. A red light connected to the Photohelic gauge is located in a common hallway in the basement. When the vacuum reaches the pre-set low vacuum level the red light will become illuminated. A sign is posted near the light and states that if the red light is illuminated that CA RICH should be contacted immediately. A schematic of the SSDS is presented as Figure 10 and riser details as Figure 11.

A series of pilot tests were conducted on April 6, 2011 utilizing a 4-inch diameter Fantech™ model HP2190 and a six-inch diameter Fantech™ model HP220 vapor abatement fan to apply a vacuum on each vent. The pilot test began on Building B Vent D by measuring the negative pressure at each valve location and manifold stack separately with a digital manometer while the

other three valves were closed. After the negative pressure at each location was obtained all four valves were opened and negative pressure readings were obtained at each location to simulate operating conditions. After approximately 35 minutes of operation the results indicated that the HP2190 model fan produced a flow of 120 cubic feet per minute (cfm) and a vacuum range of -0.09 to -0.037 inches of water for vent D with all valves open. The second stage of the pilot test conducted on Building B Vent D was conducted in a similar fashion with a six-inch Fantech™ model HP220 vapor abatement fan to apply a vacuum on each vent. After approximately 35 minutes of operation the results indicated that the six-inch diameter fan produced a flow of 180 cfm and a vacuum range of -0.23 to -0.09 inches of water for vent D with all valves open.

Based on the results of the pilot tests, it was recommended that Fantech™ Model HP220 vapor mitigation fan should be utilized for each building. The mitigation system installation record is included as Appendix I. After installation a start-up test was conducted to confirm that sufficient vacuum has been achieved beneath the building slab. The start-up test was conducted on February 7, 2012. The results of the start-up test confirmed that sufficient vacuum has been obtained. The PID meter registered zero at all locations. The results of the pilot test are illustrated on Figures 5 and 6. The SSDS start-up results are illustrated on Figure 7. The Fantech™ Model HP220 details are included in Appendix H. The Photohelic® and red-light details are included as an attachment in the Corrective Measures Report located in Appendix G of this document.

The SSDS was inspected during the Site inspection on April 26, 2024 and was found to exhibit a vacuum reading of -0.230 inches of water at the manifold main in the basement. The four vents in the basement (located in Room C-08 Storage Room) were found to exhibit the following vacuum readings:

Vent A = -0.099 inches of water

Vent B = -0.077 inches of water

Vent C = -0.066 inches of water

Vent D = -0.059 inches of water

No PID readings were observed at the vents in the basement. The roof top fan exhibited a vacuum reading of -0.70 inches of water. No PID readings were observed at the roof top vent. A copy of the O&M checklist is included in Appendix F.

5.0 INSTITUTIONAL AND ENGINEERING CONTROL (I & EC) PLAN COMPLIANCE REPORT

5.1 Institutional Controls

A series of Institutional Controls (ICs) were required at the Site to: (1) implement, maintain and monitor Engineering Control Systems; (2) prevent future exposure to residual contamination by controlling disturbances of the subsurface contamination; (3) restrict the use of the Site to residential/commercial uses only. Adherence to these ICs on the Site is required under the Environmental Easement and is implemented under the SMP. The ICs are:

- Compliance with the Environmental Easement and the SMP by the Grantor and the Grantor's successors and assigns;
- All ECs must be operated and maintained as specified in the SMP;
- The composite cover system must be inspected, certified, and maintained as required by the SMP;
- All ECs must be inspected and certified at a frequency and in the manner defined in the SMP;
- Environmental and/or public health monitoring must be performed as defined in the SMP;
- Data and information pertinent to Site Management for the Site must be reported at the frequency and in a manner defined in the SMP;
- On-site environmental monitoring devices must be protected and replaced as necessary to ensure the devices function in the manner specified in the SMP; and,
- ECs may not be discontinued without an amendment or the extinguishment of the Environmental Easement.
- Vegetable gardens and farming on the Site are prohibited;
- The use of groundwater underneath the Site is prohibited without treatment rendering it safe for intended purpose;
- All future activities on the Site that will disturb residual contaminated material are prohibited unless they are conducted in accordance with the soil management provisions in the SMP;
- The Site may only be used for residential/commercial use provided that the long-term IC/ECs included in the SMP are employed; and,

- The Site may not be used for a less restrictive use without an amendment or extinguishment of the Environmental Easement.

The environmental easement on this property is enforceable in perpetuity and is the mechanism that will be used to continually implement, maintain, monitor, and enforce such specified controls both by the BCP Volunteer, the BCP Volunteer's successors and assigns, and by State or local governments. A copy of the environmental easement with proof of filing with the responsible municipal authority is enclosed in Appendix J.

5.2 Engineering Controls

Engineering Controls (ECs) at the Site consist of a vapor barrier, a composite cover system and an SSDS. Assurance of the ECs developed for the Site will be achieved using a combination of site inspections, monitoring, and annual certifications. The engineering controls were inspected and evaluated on April 26, 2024 by Jason T. Cooper, NYSPG. Details regarding the engineering controls and their inspection are outlined in Section 4.0.

5.3 Certification

The annual certification for the Site consists of a completed NYSDEC IC/EC Certification Form for BCP Site # C203041. The completed IC/EC Certification Form was signed on May 10, 2024 and is enclosed as Appendix C. The annual certification was prepared in accordance with the SMP and has been certified by Mr. Michael Wadman, on behalf of the Owner, Courtlandt Corners II Associates, L.P. and Jason T. Cooper, NYSPG, a Qualified Environmental Professional.

6.0 MONITORING PLAN COMPLIANCE REPORT

6.1 Groundwater Monitoring Well Installation

From March 26 to March 28, 2012, three groundwater monitoring wells (MW-1, MW-2, MW-3) were installed using the hollow stem auger drilling method to 25 feet below grade. The wells were installed along the East 161st Street and Melrose Avenue sidewalks. Groundwater was encountered from 7.51 to 13.02 feet above mean sea level (BBD). The monitoring well locations are illustrated on Figure 2.

Each well was constructed of two-inch diameter schedule 40 PVC casing and two-inch diameter 0.020-inch slotted (20 slot) pipe screen flush-threaded onto the PVC casing. A sand pack of number two Morie sand was then placed around the screen to two feet above the top of the

screened interval and covered with two feet of bentonite pellets. The bentonite pellets were given time to hydrate (i.e. expand) before filling the remainder of the borehole with drill cuttings. The wells were completed with locking j-plugs and a flush mount manhole cover. Drill cuttings not used to backfill the borehole were drummed and disposed of off-site. Boring logs and monitoring well construction details are illustrated in Appendix D.

6.2 Groundwater Monitoring Well Development

Once installed, the wells were developed by pumping and surging using a small-diameter submersible pump until relatively turbidity-free groundwater was yielded. The development water was drummed and properly disposed of off-site. Well development information was recorded on well construction logs, which are enclosed as Appendix D.

6.3 Groundwater Monitoring Well Survey

The well casing elevations of the newly installed wells, MW-1, MW-2, and MW-3 were surveyed on April 18, 2012, by Montrose Surveying Company, a New York State licensed surveyor, to the nearest 0.01-foot. Depth to groundwater was measured the same day. The elevations were then plotted and a water table elevation contour map was prepared to determine the horizontal direction of groundwater flow. Based upon the data collected on April 17, 2012, the Site-specific direction of groundwater flow is toward the northeast. The groundwater elevation contour map as well as a tabulation of the casing elevations and depth to water measurements is included on Figure 3.

6.4 Groundwater Monitoring Well Sampling Termination and Well Abandonment

Groundwater sampling at the Site was terminated by NYSDEC after the 2016 sampling round. The groundwater monitoring wells were abandoned on February 26, 2018 and the revised SMP was submitted on March 3, 2018. No groundwater samples were collected in 2017 and no groundwater sampling events are planned for the future.

7.0 OPERATION & MAINTENANCE PLAN COMPLIANCE REPORT

7.1 Sub-slab Depressurization System

The original Site Management Plan prepared for this Site by Environmental Resource Management dated December 2010 included a specification for a warning device to alarm in the event the blower is deactivated or if the flow drops below a set point. When CA RICH assumed responsibility of the project, the SSD system did not have an alarm and monitoring had not been completed. A Corrective Measure Workplan was submitted to NYSDEC in December 2012 and implemented in May 2013. The implementation of the Corrective Measure Workplan included the installation of an alarm and Photohelic gauge on each of the two risers. A red-light indicator was remotely connected to Photohelic gauge. The red-light indicator is located in a common hallway near the entrance to the elevator in the basement. The Photohelic gauge has a pre-set adjustable low-level alarm set points. If the vacuum drops to or below this value the red light becomes illuminated. A sign is posted next to the gauge indicating that if the light becomes illuminated, then CA RICH should be notified. Modifications to the engineering control were certified by a Professional Engineer in 2013.

The SSDS has remained in continuous operation since the last annual inspection and has been functioning as-designed. The checklist from the most recent operations and maintenance visit is enclosed as Appendix F.

8.0 CONCLUSIONS AND RECOMMENDATIONS

The overall objective of the remedial action was to remediate environmental conditions at the Site to the satisfaction of the NYSDEC and NYSDOH for the future restricted residential/commercial use. As documented in the FER (Ref. 6), the results of the remedial activities conducted at the Site indicate that the identified areas of concern were satisfactorily addressed. NYSDEC issued a Certificate of Completion in October 2010 after reviewing the FER and SMP.

Based on the evaluation of the inspection and monitoring data, the following has been concluded:

- ECs and associated ICs were in place, performed properly, and remain effective;
- The monitoring plan was properly implemented;
- Operation and maintenance activities were conducted properly;

- The Photohelic gauges and associated red lights are operating properly; and,
- The remedy continues to be protective of public health and the environment and compliant with the decision document for the Site.

Based on the above conclusions, the following is recommended:

- Operations and maintenance activities should continue in accordance with the scheduled outlined in the approved SMP.
- The next Periodic Review Report should be submitted by May 31, 2025. This report shall only include the annual inspection of the Site.

9.0 REFERENCES

1. ERM Consulting and Engineering, Inc. Site Management Plan. September 2010, Revised June 2013, Revised March 2018 (Draft).
2. AKRF. Phase I ESA. May 2006.
3. Fleming-Lee Sue, Inc. Phase II ESA. May 2007.
4. ERM Consulting and Engineering, Inc. Remedial Investigation Report. June 2008.
5. ERM Consulting and Engineering, Inc. Remedial Action Work Plan. June 2008.
6. ERM Consulting and Engineering, Inc. Final Engineering Report. October 2010.
7. NYSDEC. 6 NYCRR Part 375 Environmental Remediation Programs, Subparts 375-1 to 375-4 & 375-6. December 2006.
8. NYSDEC. Technical and Operational Guidance Series (1.1.1) Ambient Water Quality Standards and Guidance Values. October 1993.

FIGURES

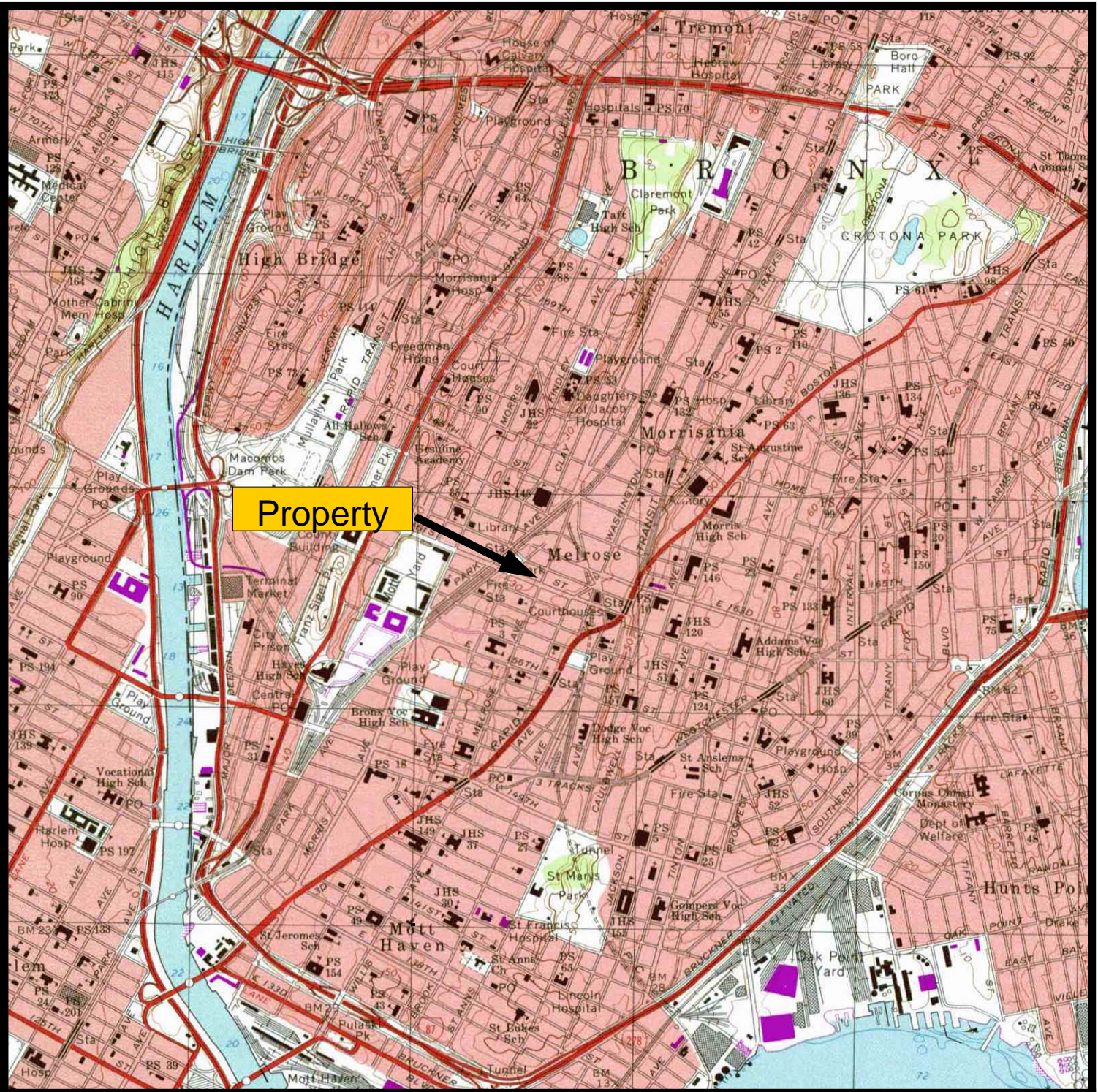

Property



CA RICH CONSULTANTS, INC.
 17 Dupont Street,
 Plainview, NY 11803

APPROX. SCALE (ft.)



0 1,200 2,400 N



TITLE: SITE LOCATION MAP		DATE: 6/5/12
FIGURE: 1		SCALE: AS SHOWN
DRAWING:	Courtlandt Corners II 875 Melrose Avenue Bronx, New York	DRAWN BY: S.T.M.
		APPR. BY: D.S.

Adapted from USGS 1995 Central Park Quadrangle Map.

E. 162nd Street

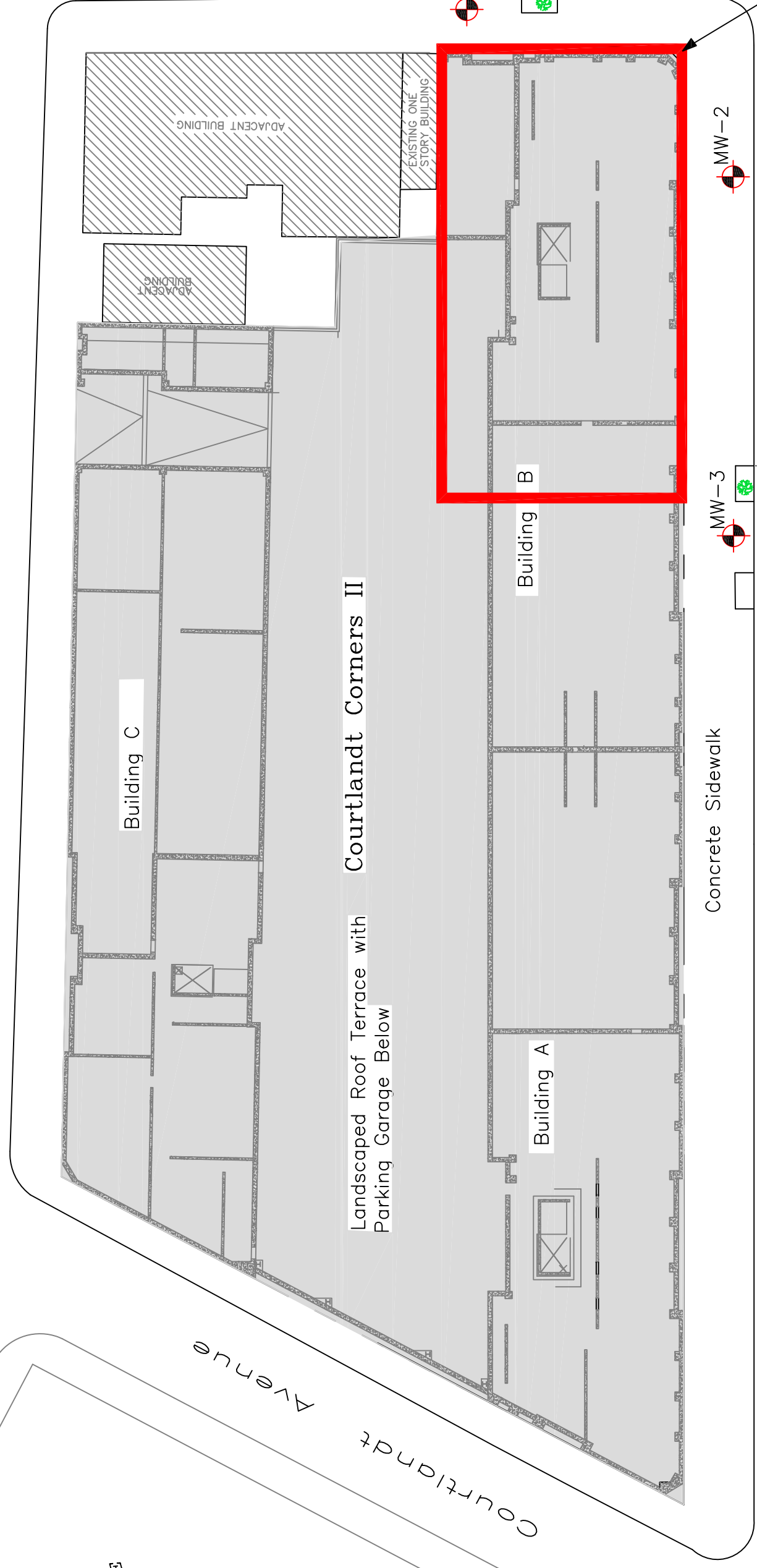
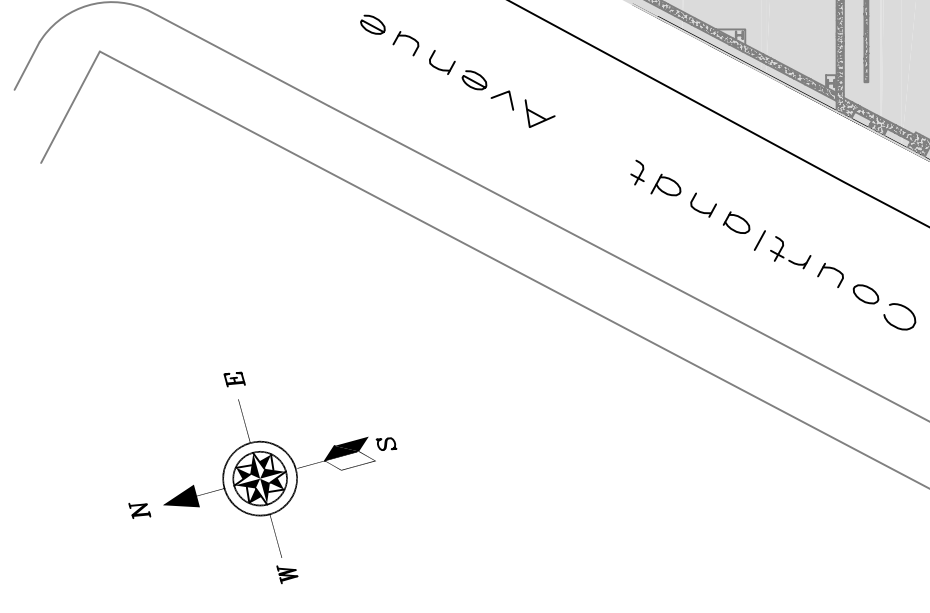

BCP Site Boundary

E. 161st Street

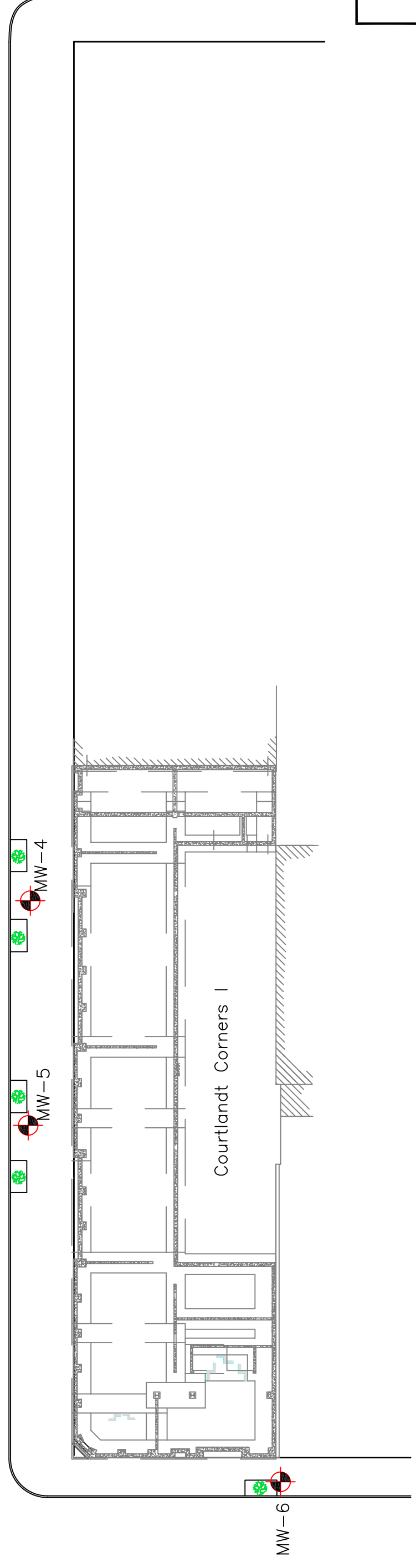

LEGEND

- MW-3 Groundwater Monitoring Well Location and Designation
- Trees
- Composite Cover System Over Entire Redevelopment Site

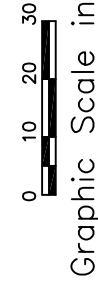

NOTES
 1) Drawing adapted from Montrose Survey Co. LLC date April 18, 2012 and Dattner Architecture building plans.

CA RICH CONSULTANTS, INC.

Environmental Specialists Since 1982
 17 Dupont Street, Plainview, New York 11803

TITLE: Site Plan		DATE: 4/16/2013
SCALE: AS SHOWN		DRAWN BY: J.T.C.
FIGURE: 2	DRAWING NO.: PRR CCII	APPR BY: R.J.I.

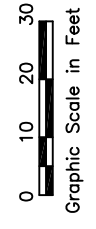
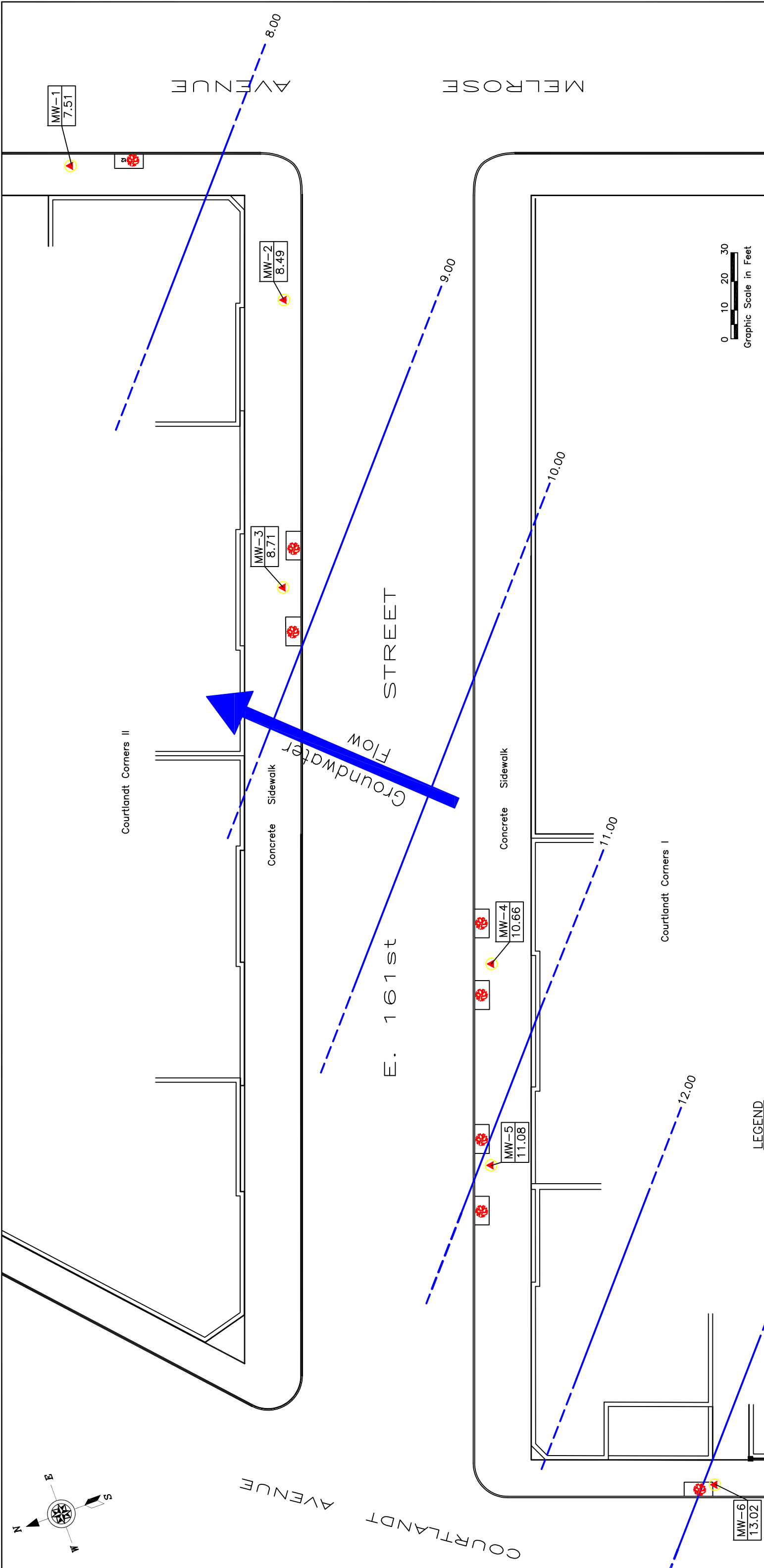

CA RICH CONSULTANTS, INC.
 Environmental Specialists Since 1982
 17 Dupont Street, Plainview, New York 11803

TITLE: Groundwater Contour Elevation
 Map April 16, 2012

DATE: 6/12/2012

SCALE: AS SHOWN

DRAWN BY: J.T.C.

APPR BY: D.S.

FIGURE: 3

DRAWING NO: 2012-1

Courtlandt Corners I & II
 870 Courtlandt Avenue &
 875 Melrose Avenue
 Bronx, New York

Well ID	Top of Casing (Feet)	Depth to Water (Feet)	Water Table Elevation (Feet)
MW-1	21.41	13.90	7.51
MW-2	24.15	15.66	8.49
MW-3	26.24	17.53	8.71
MW-4	29.53	18.87	10.66
MW-5	30.95	19.87	11.08
MW-6	28.93	15.91	13.02

- LEGEND**
- Monitoring Well
 - Groundwater Monitoring Well ID and Water Table Elevation (Feet Above Mean Sea Level)
 - Groundwater Elevation Contour Line (Dashed where inferred)
 - Tree

NOTES

- 1) Elevations shown hereon refer to the borough of the Bronx Topographical Bureau Datum, which is 2.608 feet above mean sea level
- 2) All water table measurements are in feet above mean sea level
- 3) Drawing adapted from Montrose Survey Co. LLC date April 18, 2012.

H:\Drawings\Phlips Courtlandt Corners\2012-1

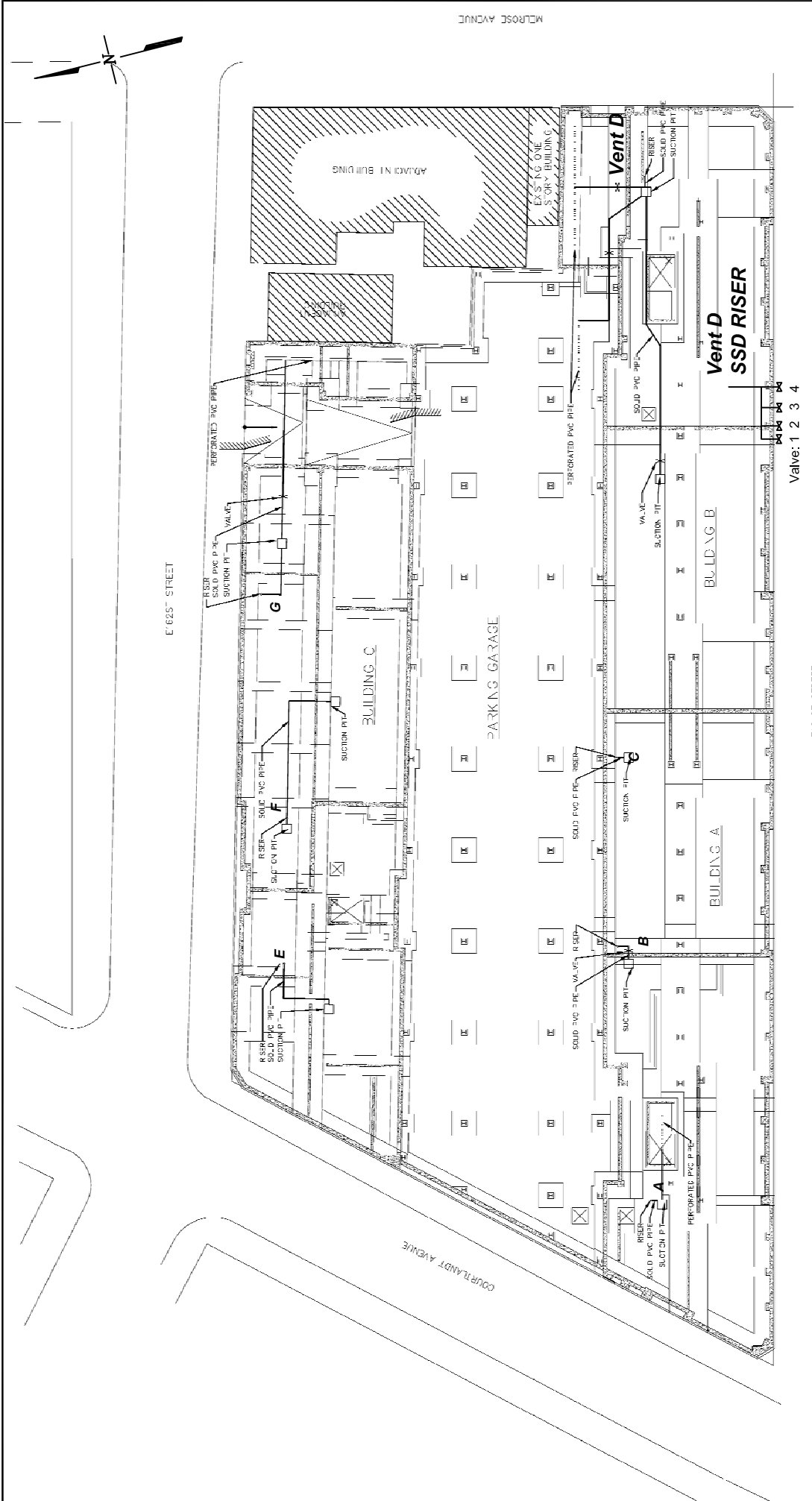
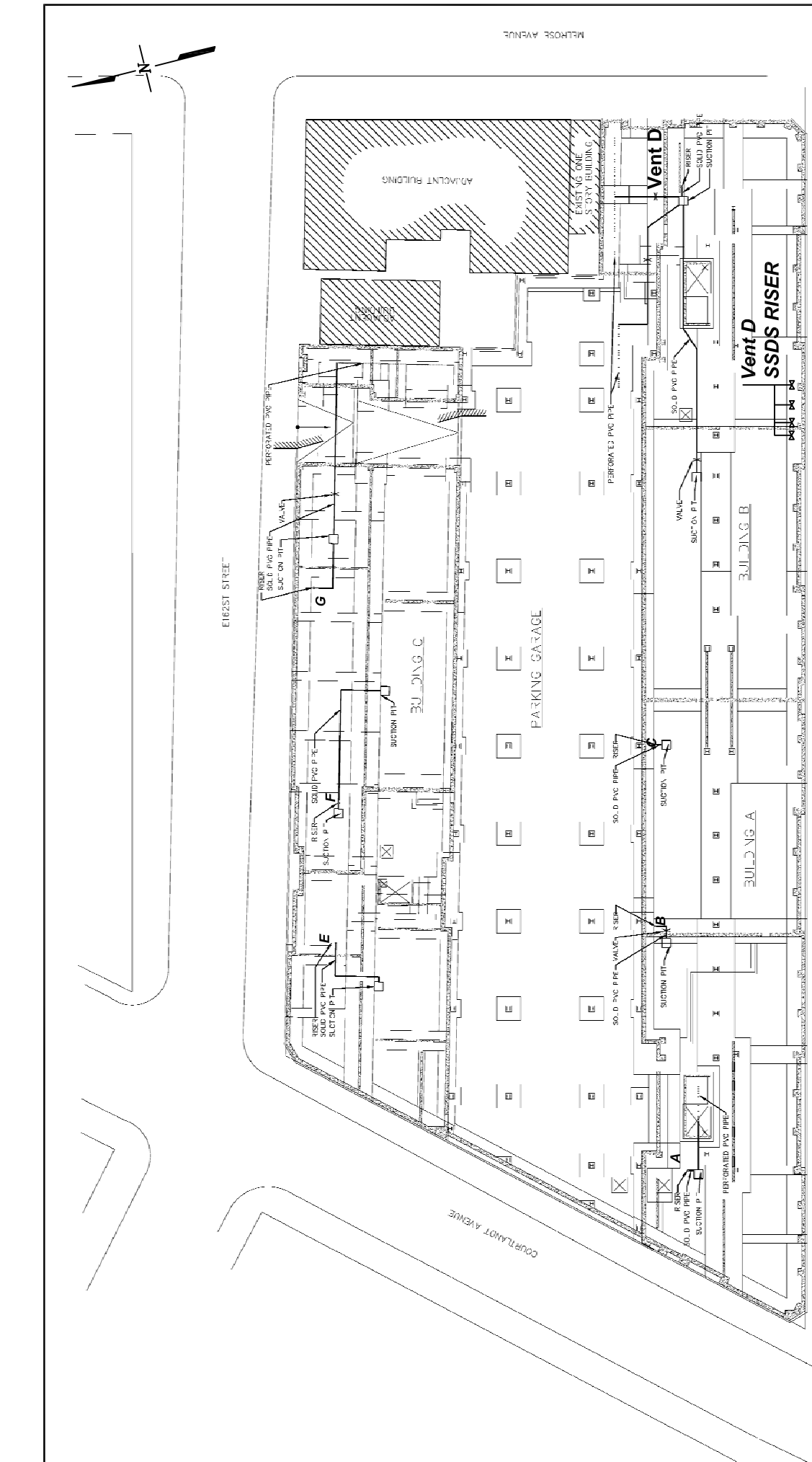

FIGURE	4	DRAWING NO:	2012-2A
CA RICH CONSULTANTS, INC. Environmental Specialists Since 1982 17 Dupont Street, Plainview, New York 11803		DRAWN BY: T.R.B. APPR. BY: D.S.	
TITLE: Pilot Test Results for Vent D April 6, 2011 with Blower HP2190		DATE: 6/14/2012	SCALE: As Shown
Test No. 1 Date: 4/6/2011 Start Time: 10:00 End Time: 10:15 Blower Model: HP2190 Vent Diameter (inches): 6" Vent No. D: Valve 1 open, rest closed Valve 1: -0.389 "H2O Valve 2: -0.002 "H2O Valve 3: -0.008 "H2O Valve 4: -0.006 "H2O Manifold Stack: -0.0985 "H2O	Test No. 2 Date: 4/6/2011 Start Time: 10:15 End Time: 10:20 Blower Model: HP2190 Vent Diameter (inches): 6" Vent No. D: Valve 2 open, rest closed Valve 1: -0.004 "H2O Valve 2: -0.215 "H2O Valve 3: -0.027 "H2O Valve 4: -0.010 "H2O Manifold Stack: -0.06 "H2O	Test No. 3 Date: 4/6/2011 Start Time: 10:20 End Time: 10:25 Blower Model: HP2190 Vent Diameter (inches): 6" Vent No. D: Valve 3 open, rest closed Valve 1: -0.001 "H2O Valve 2: -0.020 "H2O Valve 3: -0.555 "H2O Valve 4: -0.006 "H2O Manifold Stack: -0.600 "H2O	Test No. 4 Date: 4/6/2011 Start Time: 10:25 End Time: 10:30 Blower Model: HP2190 Vent Diameter (inches): 6" Vent No. D: Valve 4 open, rest closed Valve 1: -0.004 "H2O Valve 2: -0.15 "H2O Valve 3: -0.040 "H2O Valve 4: -0.236 "H2O Manifold Stack: -0.292 "H2O
Test No. 5 Date: 4/6/2011 Start Time: 10:30 End Time: 10:35 Blower Model: HP2190 Vent Diameter (inches): 6" Vent No. D: All Valves Open Valve 1: -0.055 "H2O Valve 2: -0.045 "H2O Valve 3: -0.040 "H2O Valve 4: -0.037 "H2O Manifold Stack: -0.09 "H2O	Note: Only vent D of building B is part of SSDs. Vents A-C and E-G are passive vents.		



Test No.	Date	Start Time	End Time
Test No. 1	4/6/2011	10:40	10:45
Blower Model:	HP220		
Vent Diameter (inches):	6"		
Vent No. D:	All Valves Open		
Valve 1:	-0.136 "H2O		
Valve 2:	-0.108 "H2O		
Valve 3:	-0.099 "H2O		
Valve 4:	-0.09 "H2O		
Manifold Stack:	-0.23 "H2O		
Test No. 2	4/6/2011	10:45	10:50
Blower Model:	HP220		
Vent Diameter (inches):	6"		
Vent No. D:	Valve 1 open, rest closed		
Valve 1:	-0.082 "H2O		
Valve 2:	-0.004 "H2O		
Valve 3:	-0.015 "H2O		
Valve 4:	-0.012 "H2O		
Manifold Stack:	-0.23 "H2O		
Test No. 3	4/6/2011	10:50	10:55
Blower Model:	HP220		
Vent Diameter (inches):	6"		
Vent No. D:	Valve 2 open, rest closed		
Valve 1:	-0.001 "H2O		
Valve 2:	-0.445 "H2O		
Valve 3:	-0.049 "H2O		
Valve 4:	-0.016 "H2O		
Manifold Stack:	-0.23 "H2O		
Test No. 4	4/6/2011	10:55	11:00
Blower Model:	HP220		
Vent Diameter (inches):	6"		
Vent No. D:	Valve 3 open, rest closed		
Valve 1:	-0.006 "H2O		
Valve 2:	-0.34 "H2O		
Valve 3:	-1.104 "H2O		
Valve 4:	-0.036 "H2O		
Manifold Stack:	-1.18 "H2O		
Test No. 5	4/6/2011	11:00	11:15
Blower Model:	HP220		
Vent Diameter (inches):	6"		
Vent No. D:	Valve 4 open, rest closed		
Valve 1:	-0.1 "H2O		
Valve 2:	-0.26 "H2O		
Valve 3:	-0.770 "H2O		
Valve 4:	-0.545 "H2O		
Manifold Stack:	-1.18 "H2O		

Valves: 1 2 3 4

CA RICH CONSULTANTS, INC.
 Environmental Specialists Since 1982
 17 Dupont Street, Plainview, New York 11803

DATE: 6/14/2012
SCALE: As Shown
DRAWN BY: T.R.B.
APPR. BY: D.S.

TITLE: Pilot Test Results for Vent-D
 April 6, 2011 with Blower HP220

FIGURE: 5
DRAWING NO.: 2012-2A-4

Courtlandt Corners II
 875 Melrose Ave.
 Bronx, New York

Note: Only vent D of building B is part of SSDS.
 Vents A-C and E-G are passive vents

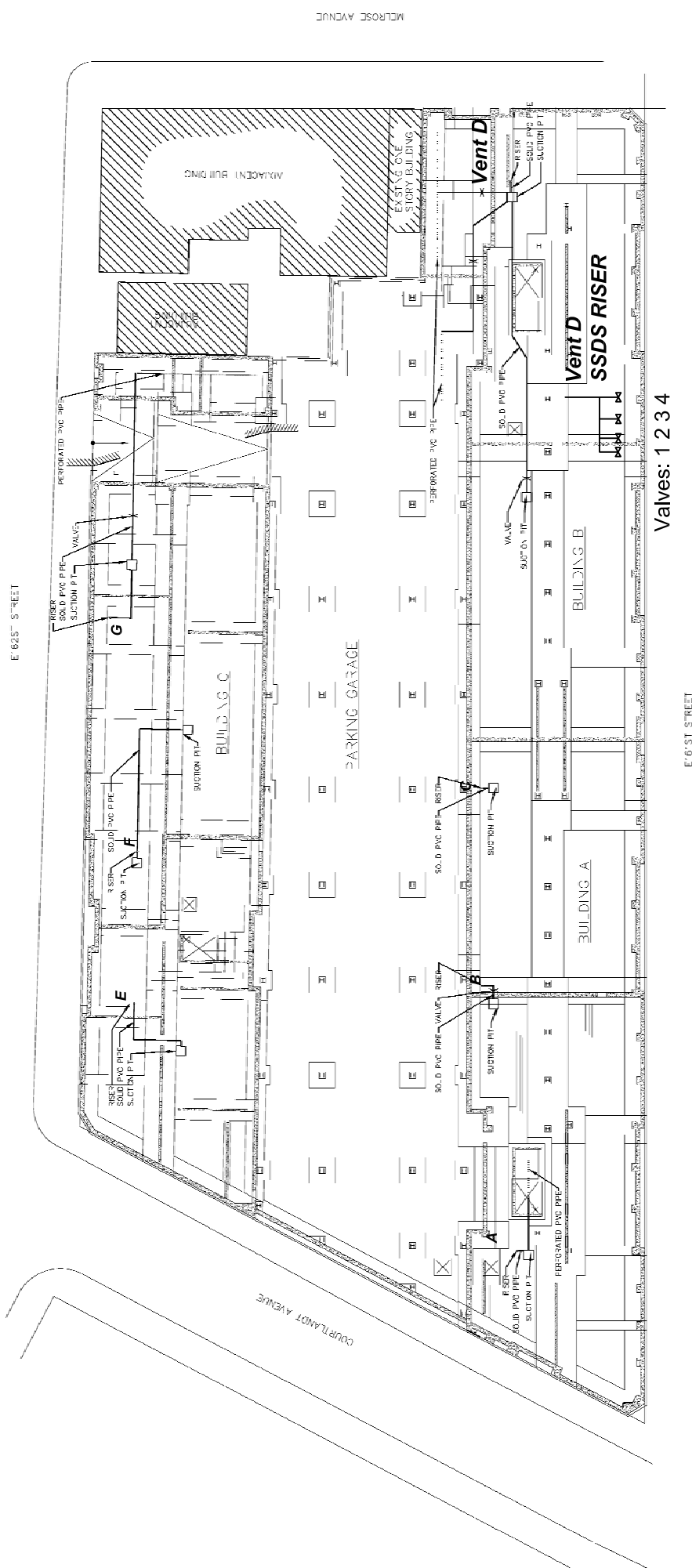
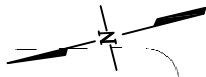

Valves: 1 2 3 4

EAST STREET

Start Time: 10:30
 Blower Model: HP220
 Vent Diameter (inches): 6"
 Vent No. D; All Valves Open
 Valve 1: -0.13 "H2O
 Valve 2: -0.12 "H2O
 Valve 3: -0.10 "H2O
 Valve 4: -0.09 "H2O
 Manifold Stack: -0.19 "H2O

Note: Only vent D of building B is part of SSDS. Vents A-C and E-G are passive vents.

CA RICH CONSULTANTS, INC.

Environmental Specialists Since 1982
 17 Dupont Street, Plainville, New York 11803

TITLE: Startup Results for Vent D Feb. 8, 2012		DATE: 6/14/2012
FIGURE: 6		SCALE: As Shown
DRAWING NO.: 2012-2B1		DRAWN BY: T.R.B.
		APPR. BY: D.S.

ALTA/ACSM LAND TITLE SURVEY

BLOCK: 2408
LOT: 1

TOTAL LOT AREA=
SQ. FT.: 55,299.83
ACRES: 1.2695

TITLE NO. 3212-00084

NOTES:

- THERE ARE "50" MARKED PARKING STALLS BELOW GRADE ON THIS SITE.
- THE ABOVE CAPTIONED PREMISES LIES WITHIN FLOOD ZONE - X PANEL: 0083F COMMUNITY: 360497 EFFECTIVE DATE: SEPTEMBER 5, 2007
- THE ABOVE CAPTIONED PREMISES HAS AN "R8 WITH A C1-4 COMMERCIAL OVERLAY" ZONING CLASSIFICATION.

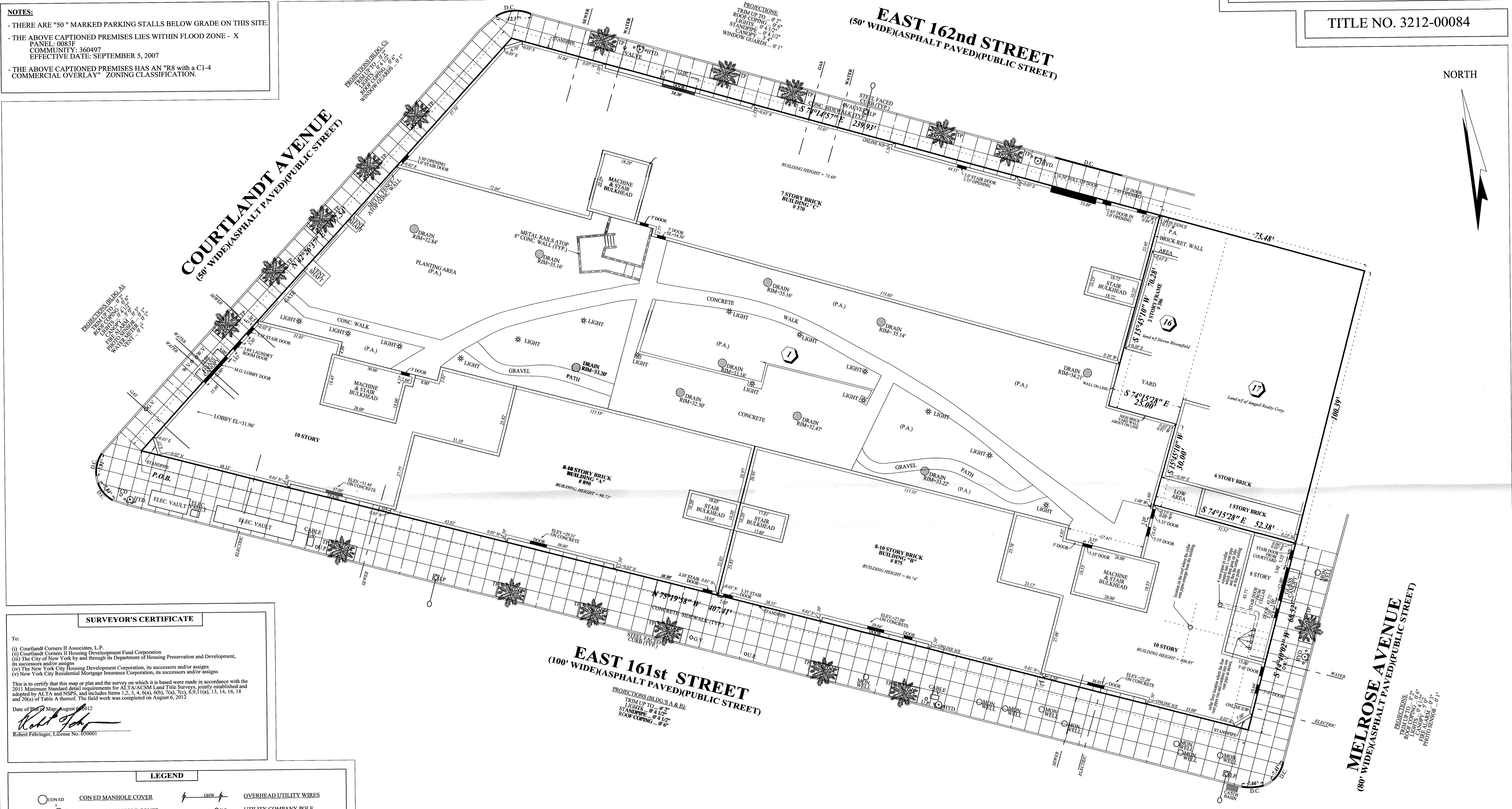

SURVEYOR'S CERTIFICATE

To:
(i) Courtlandt Corners II Associates, L.P.
(ii) Courtlandt Corners II Housing Development Fund Corporation
(iii) The City of New York by and through its Department of Housing, Preservation and Development, its successors and/or assigns
(iv) The New York City Housing Development Corporation, its successors and/or assigns
(v) New York City Residential Mortgage Insurance Corporation, its successors and/or assigns

This is to certify that this map or plat and the survey on which it is based were made in accordance with the 2011 Minimum Standard detail requirements for ALTA/ACSM Land Title Surveys, jointly established and adopted by ALTA and NSPS, and includes items 1, 2, 3, 4, 6(a), 6(b), 7(a), 7(c), 8, 9, 11(a), 13, 14, 16, 18 and 20(a) of Table A thereof. The field work was completed on August 6, 2012.

Date of Plat: August 6, 2012
Robert Fehringer
Robert Fehringer, License No. 050001

LEGEND

- | | | | |
|--------|--|----------|--------------------------|
| CON ED | CON ED MANHOLE COVER | OHW | OVERHEAD UTILITY WIRES |
| E | ELECTRIC MANHOLE COVER | U.P. | UTILITY COMPANY POLE |
| — | UNDERGROUND ELECTRIC DUCTS | — | STREET LIGHT |
| W | DEPARTMENT OF WATER SUPPLY MANHOLE COVER | M.L.P. | METAL LIGHT POLE |
| — | WATER MAIN | M.T.L.P. | METAL TRAFFIC LIGHT POLE |
| S | SEWER MANHOLE COVER | T.S.P. | TRAFFIC SIGN POLE |
| — | SANITARY SEWER | F.H. | FIRE HYDRANT |
| — | STEAM MAIN | P.M. | PARKING METER |
| — | DEPARTMENT OF WATER SUPPLY WATER GATE | C.B. | CATCH BASIN |
| — | WATER VALVE | O.F. | OIL FILL |
| — | GAS MAIN | T.P. | TREE PIT |
| — | GAS CO. MANHOLE | D.C. | DROP CURB |
| — | GAS VALVE | S.P. | STAND PIPE |
| — | CLEAN OUT MANHOLE COVER | C.F. | CHAIN LINK FENCE |
| — | TELEPHONE MANHOLE COVER | W.F. | WROUGHT IRON FENCE |
| — | TELEPHONE LINES | W.S.F. | WOOD STOCKADE FENCE |
| | | P.R.F. | POST AND RAIL FENCE |

VICINITY MAP

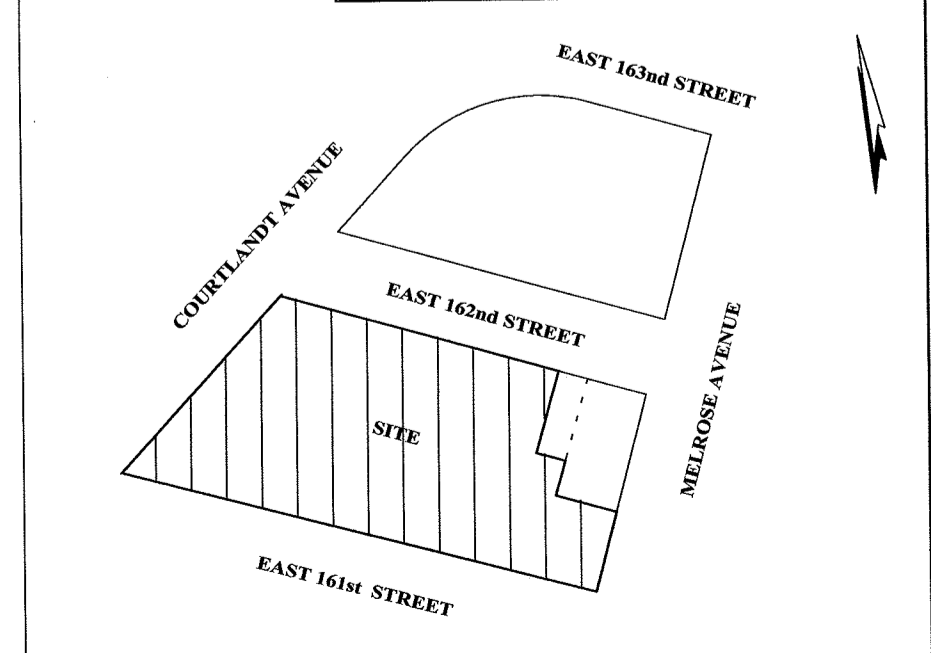

LEGAL DESCRIPTION

ALL those certain plots, pieces or parcels of land, lying and being in the Borough of the Bronx, County of Bronx, City and State of New York, and being bounded and described as follows:
BEGINNING at the corner formed by the intersection of the northerly side of East 161st Street (100 feet wide) with the easterly side of Courtlandt Avenue (60 feet wide);
 THENCE northerly along the easterly side of Courtlandt Avenue, 197.54 feet to the intersection of the easterly side of Courtlandt Avenue with the southerly side of East 162nd Street, 239.93 feet to the westerly line of lands now or formerly of Mary Lozowski;
 THENCE easterly along the southerly side of East 162nd Street, 239.93 feet to the westerly line of lands now or formerly of Mary Lozowski;
 THENCE along said lands,
 South 15 degrees 45 minutes 10 seconds West 70.28 feet; and South 74 degrees 15 minutes 28 seconds East 25 feet to the westerly line of lands now or formerly of Anguill Realty Corp.;
 THENCE along said lands,
 South 15 degrees 45 minutes 10 seconds West 30 feet; and South 74 degrees 15 minutes 28 seconds East 52.38 feet to the westerly side of Melrose Avenue (80 feet wide);
 THENCE southerly along the westerly side of Melrose Avenue, 68.52 feet to the corner formed by the intersection of the westerly side of Melrose Avenue with the southerly side of East 161st Street;
 THENCE westerly along the northerly side of East 161st Street, 407.41 feet to the corner formed by the intersection of the northerly side of East 161st Street with the easterly side of Courtlandt Avenue, the point and place of **BEGINNING**.

SURVEY REVISED: JANUARY 22, 2013
Monitoring wells & Vent pipe information added

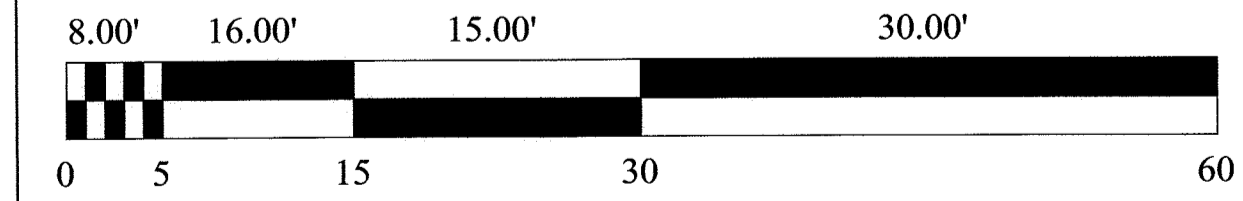

SCALE: 1" = 16' SURVEYED: AUGUST 6, 2012

SURVEY OF PROPERTY SITUATED IN:
"COURTLANDT CORNERS II"
361 E. 161ST STREET
BOROUGH OF BRONX
COUNTY OF BRONX
CITY OF NEW YORK
STATE OF NEW YORK

FEHRINGER SURVEYING, P.C.
ROBERT FEHRINGER
LICENSED LAND SURVEYOR
2200 JACKSON AVENUE
SEAFORD, N.Y. 11783
(516) 763 - 5515 FAX NO. (516) 763 - 5525

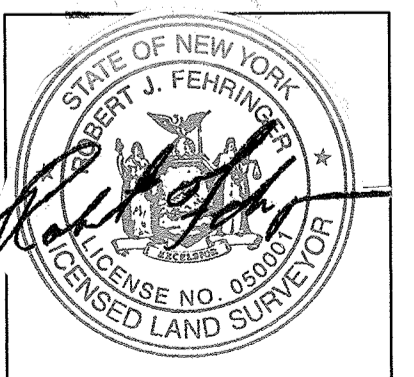

Riser Detail (NTS)

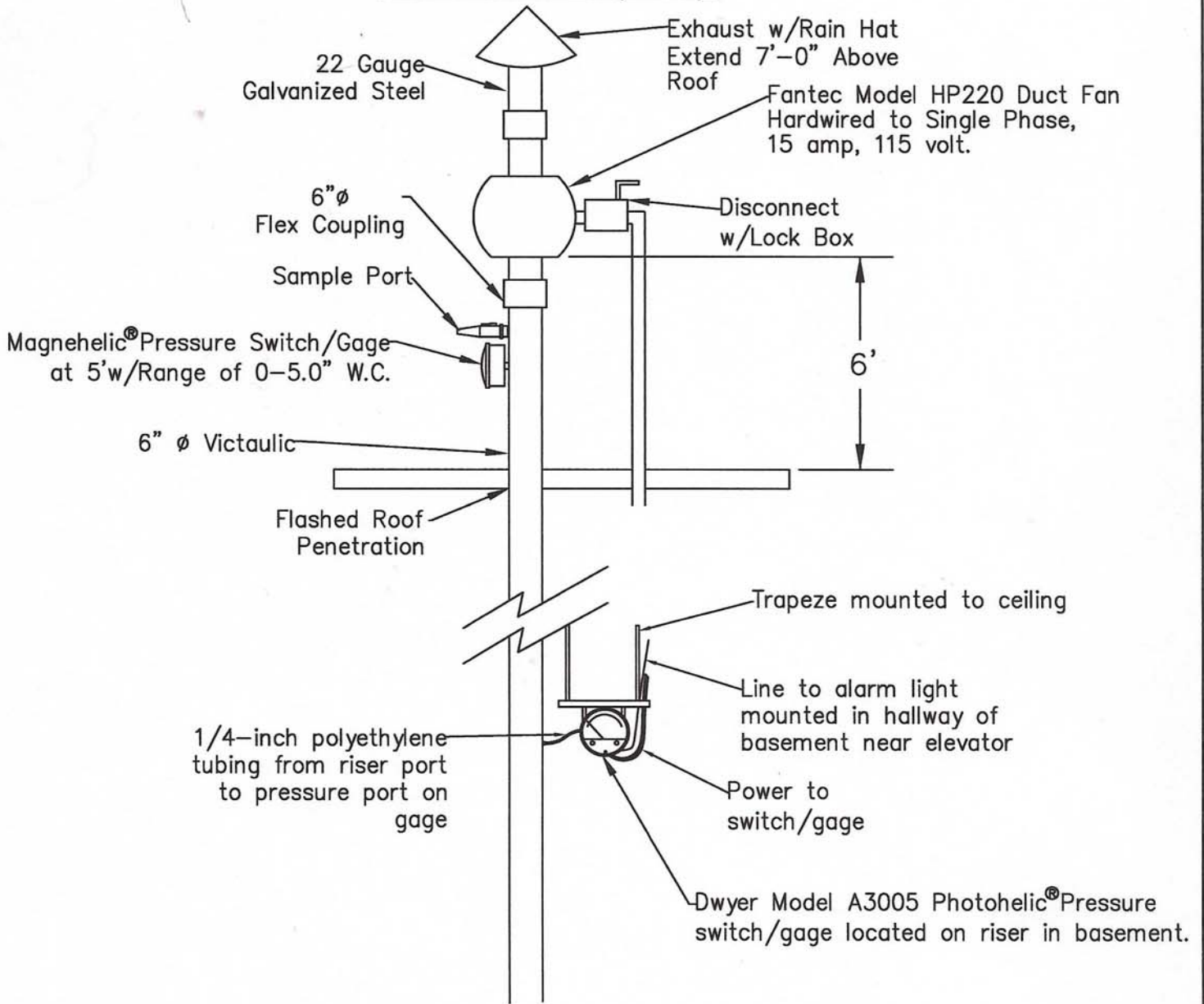

Stephen J. Osmundsen, P.E.

Consulting Engineer
514 Pantigo Road #16, East Hampton, NY 11937

TITLE: Typical Riser Detail		DATE: 4/26/2013
FIGURE: 8		SCALE: Not to Scale
DRAWING NO: 2013-1	Courtlandt Corners I and II 870 Courtlandt Avenue & 875 Melrose Ave. Bronx, New York	DRAWN BY: T.R.B. APPR. BY: S.J.O.

APPENDIX A

Selected Photographs



Front of the Site building.



Front of the Site building along Melrose Avenue.

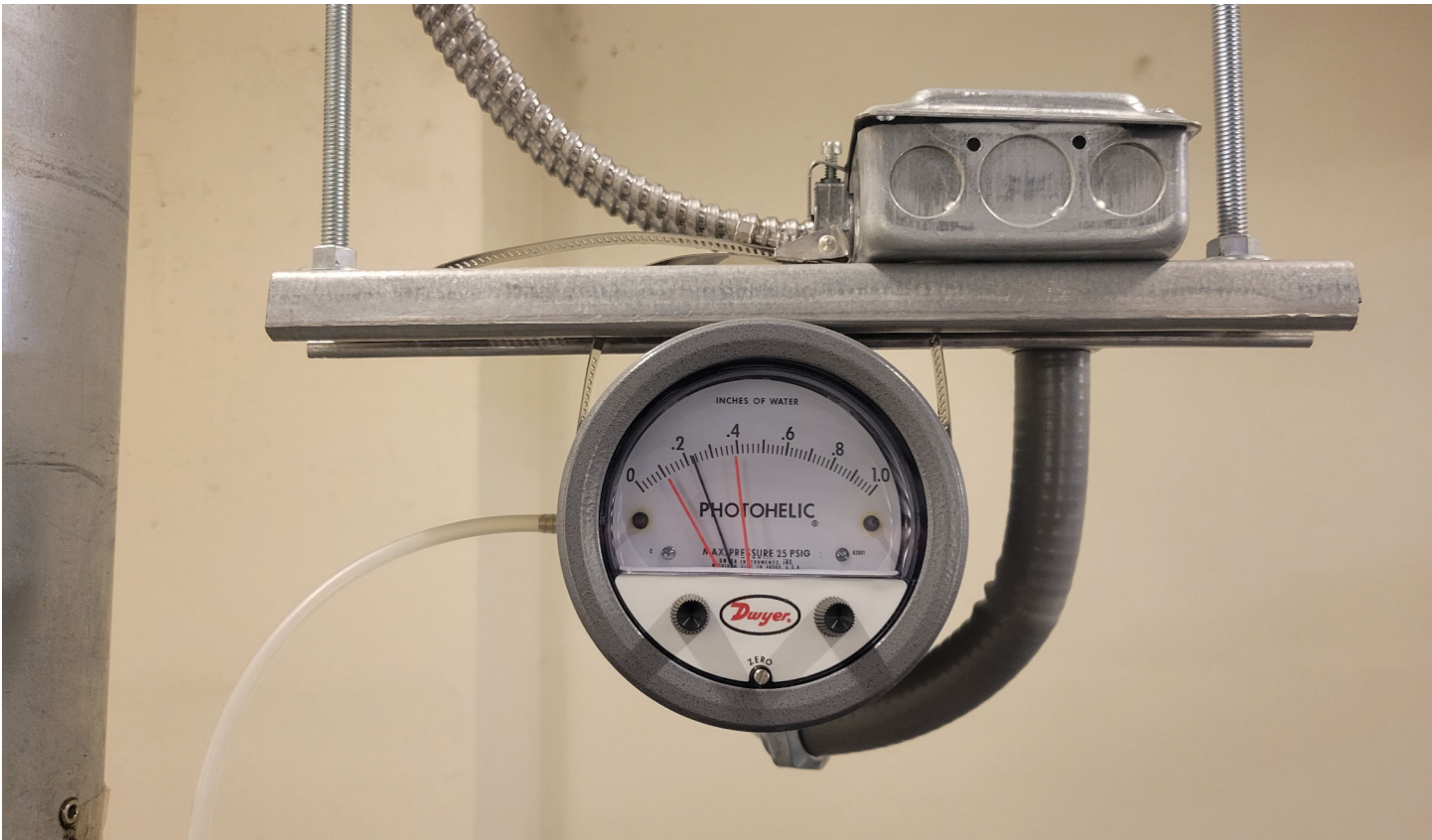

Vacuum gauge in Room C-08



Testing the red light alarm.



SSDS piping on the roof.

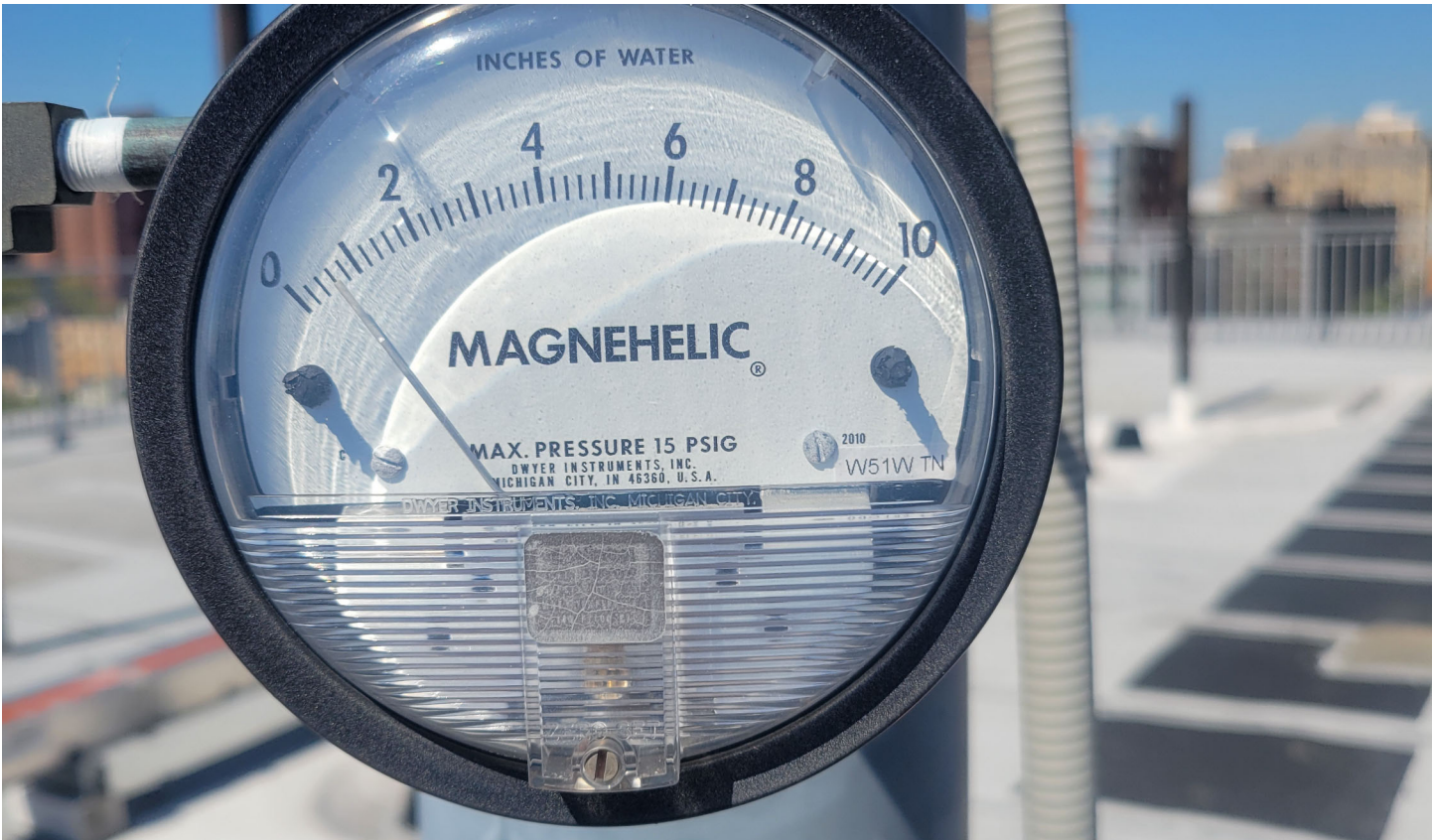

Vacuum reading at the roof.



Basement hallway.



Vacuum at Riser A.



Vacuum at Riser B.



Vacuum at Riser C.



Vacuum at Riser D.



Courtyard area.



Courtyard area.

APPENDIX B

Site-Wide Inspection Form

**Site-Wide Inspection Check List
 Courtlandt Corners II
 875 Courtlandt Avenue
 Bronx, New York
 BCP #C203041**

Compliances to be Addressed	Comments
Provide an evaluation of the condition and continued effectiveness of engineering controls (foundation walls/slabs, vapor barrier, and concrete sidewalks).	The engineering controls appear to be effective. The SSD system is operating and the composite cover system is intact. The red warning light was tested and is operational in both the on and off position. The basement walls and floor appear to be in good condition.
Are all institutional controls, including Site usage in compliance?	Yes
What are the general Site conditions?	Site is neat and clean. The basement floors are in good condition with no observable penetrations that could compromise the vapor barrier. New epoxy has been applied to portions of the basement floor.
Are Site management activities being conducted including, confirmation sampling and a health and safety inspection?	Yes
Are all Site records up to date?	Yes
Does Site access remain available to maintain engineering controls?	Yes
Are all permits and schedules included in the Operation and Maintenance Plan in Compliance?	Yes
Are any air supply, HVAC intakes, or adjoining/adjacent buildings constructed within 10 feet of any of the SSDS exhausts?	No
Has any intrusive work been done on the site within the reporting period; if so was the composite cover system breached? If so was the SMP adhered to?	No

*Inspector- Jason T. Cooper
 Date/Time- May 4, 2023*

APPENDIX C

IC/EC Form

NEW YORK STATE DEPARTMENT OF ENVIRONMENTAL CONSERVATION

Division of Environmental Remediation

625 Broadway, 11th Floor, Albany, NY 12233-7020

P: (518)402-9543 | F: (518)402-9547

www.dec.ny.gov

3/18/2024

Michael Wadman

Courtlandt Corners II Associates, L.P.

902 Broadway

13th floor

New York, NY 10010

mwadman@phippsony.org

Re: Reminder Notice: Site Management Periodic Review Report and IC/EC Certification Submittal

Site Name: Courtlandt Corners II

Site No.: C203041

Site Address: 875 Melrose Avenue
Bronx, NY 10451

Dear Michael Wadman:

This letter serves as a reminder that sites in active Site Management (SM) require the submittal of a periodic progress report. This report, referred to as the Periodic Review Report (PRR), must document the implementation of, and compliance with, site-specific SM requirements. Section 6.3(b) of DER-10 *Technical Guidance for Site Investigation and Remediation* (available online at <http://www.dec.ny.gov/regulations/67386.html>) provides guidance regarding the information that must be included in the PRR. Further, if the site is comprised of multiple parcels, then you as the Certifying Party must arrange to submit one PRR for all parcels that comprise the site. The PRR must be received by the Department no later than **May 30, 2024**. Guidance on the content of a PRR is enclosed.

Site Management is defined in regulation (6 NYCRR 375-1.2(at)) and in Chapter 6 of DER-10. Depending on when the remedial program for your site was completed, SM may be governed by multiple documents (e.g., Operation, Maintenance, and Monitoring Plan; Soil Management Plan) or one comprehensive Site Management Plan.

A Site Management Plan (SMP) may contain one or all of the following elements, as applicable to the site: a plan to maintain institutional controls and/or engineering controls (“IC/EC Plan”); a plan for monitoring the performance and effectiveness of the selected remedy (“Monitoring Plan”); and/or a plan for the operation and maintenance of the selected remedy (“O&M Plan”). Additionally, the technical requirements for SM are stated in the decision document (e.g., Record of Decision) and, in some cases, the legal agreement directing the remediation of the site (e.g., order on consent, voluntary agreement, etc.).

When you submit the PRR (by the due date above), include the enclosed forms documenting that all SM requirements are being met. The Institutional Controls (ICs) portion of the form (Box 6) must be signed by you or your designated representative. The Engineering Controls (ECs) portion of the form (Box 7) must be signed by a Qualified Environmental Professional (QEP). If you cannot certify that all SM requirements are being met, you must submit a Corrective Measures Work Plan that identifies the actions to be taken to restore compliance. The work plan must include a schedule to be approved by the Department. The Periodic Review process will not be considered complete until all necessary corrective measures are completed and all required controls are certified. Instructions for completing the certifications are enclosed.



All site-related documents and data, including the PRR, must be submitted in electronic format to the Department of Environmental Conservation. The required format for documents is an Adobe PDF file with optical character recognition and no password protection. Data must be submitted as an electronic data deliverable (EDD) according to the instructions on the following webpage:

<https://www.dec.ny.gov/chemical/62440.html>

Documents may be submitted to the project manager either through electronic mail or by using the Department's file transfer service at the following webpage:

<https://fts.dec.state.ny.us/fts/>

The Department will not approve the PRR unless all documents and data generated in support of the PRR have been submitted using the required formats and protocols.

You may contact Marlen Salazar, the Project Manager, at 718-482-7129 or marlen.salazar@dec.ny.gov with any questions or concerns about the site. Please notify the project manager before conducting inspections or field work. You may also write to the project manager at the following address:

New York State Department of Environmental Conservation
One Hunters Point Plaza
47-40 21st Street
Long Island City, NY 11101

Enclosures

PRR General Guidance
Certification Form Instructions
Certification Forms

ec: w/ enclosures

ec: w/ enclosures

Marlen Salazar, Project Manager
Jane O'Connell, Hazardous Waste Remediation Supervisor, Region 2

CA Rich Consultants, Inc. - Jason Cooper - jcooper@carichinc.com
CA Rich Inc - Tich Izzo - rizzo@carichinc.com

The following parcel owner did not receive an ec:

Courtlandt Corners Associates Lp - Parcel Owner

Enclosure 1

Certification Instructions

I. Verification of Site Details (Box 1 and Box 2):

Answer the three questions in the Verification of Site Details Section. The Owner and/or Qualified Environmental Professional (QEP) may include handwritten changes and/or other supporting documentation, as necessary.

II. Certification of Institutional Controls/ Engineering Controls (IC/ECs)(Boxes 3, 4, and 5)

1.1.1. Review the listed IC/ECs, confirming that all existing controls are listed, and that all existing controls are still applicable. If there is a control that is no longer applicable the Owner / Remedial Party should petition the Department separately to request approval to remove the control.

2. In Box 5, complete certifications for all Plan components, as applicable, by checking the corresponding checkbox.

3. If you cannot certify "YES" for each Control listed in Box 3 & Box 4, sign and date the form in Box 5. Attach supporting documentation that explains why the **Certification** cannot be rendered, as well as a plan of proposed corrective measures, and an associated schedule for completing the corrective measures. Note that this **Certification** form must be submitted even if an IC or EC cannot be certified; however, the certification process will not be considered complete until corrective action is completed.

If the Department concurs with the explanation, the proposed corrective measures, and the proposed schedule, a letter authorizing the implementation of those corrective measures will be issued by the Department's Project Manager. Once the corrective measures are complete, a new Periodic Review Report (with IC/EC Certification) must be submitted within 45 days to the Department. If the Department has any questions or concerns regarding the PRR and/or completion of the IC/EC Certification, the Project Manager will contact you.

III. IC/EC Certification by Signature (Box 6 and Box 7):

If you certified "YES" for each Control, please complete and sign the IC/EC Certifications page as follows:

- For the Institutional Controls on the use of the property, the certification statement in Box 6 shall be completed and may be made by the property owner or designated representative.
- For the Engineering Controls, the certification statement in Box 7 must be completed by a Professional Engineer or Qualified Environmental Professional, as noted on the form.



Enclosure 2
NEW YORK STATE DEPARTMENT OF ENVIRONMENTAL CONSERVATION
 Site Management Periodic Review Report Notice
 Institutional and Engineering Controls Certification Form



	Site Details	Box 1
Site No. C203041		
Site Name Courtlandt Corners II		
Site Address: 875 Melrose Avenue Zip Code: 10451		
City/Town: Bronx		
County: Bronx		
Site Acreage: 0.160		
Reporting Period: April 30, 2023 to April 30, 2024		
		YES NO
1. Is the information above correct?		<input checked="" type="checkbox"/> <input type="checkbox"/>
If NO, include handwritten above or on a separate sheet.		
2. Has some or all of the site property been sold, subdivided, merged, or undergone a tax map amendment during this Reporting Period?		<input type="checkbox"/> <input checked="" type="checkbox"/>
3. Has there been any change of use at the site during this Reporting Period (see 6NYCRR 375-1.11(d))?		<input type="checkbox"/> <input checked="" type="checkbox"/>
4. Have any federal, state, and/or local permits (e.g., building, discharge) been issued for or at the property during this Reporting Period?		<input type="checkbox"/> <input checked="" type="checkbox"/>
If you answered YES to questions 2 thru 4, include documentation or evidence that documentation has been previously submitted with this certification form.		
5. Is the site currently undergoing development?		<input type="checkbox"/> <input checked="" type="checkbox"/>
		Box 2
		YES NO
6. Is the current site use consistent with the use(s) listed below? Restricted-Residential, Commercial, and Industrial		<input checked="" type="checkbox"/> <input type="checkbox"/>
7. Are all ICs in place and functioning as designed?		<input checked="" type="checkbox"/> <input type="checkbox"/>
IF THE ANSWER TO EITHER QUESTION 6 OR 7 IS NO, sign and date below and DO NOT COMPLETE THE REST OF THIS FORM. Otherwise continue.		
A Corrective Measures Work Plan must be submitted along with this form to address these issues.		
_____ Signature of Owner, Remedial Party or Designated Representative		_____ Date

Box 2A

8. Has any new information revealed that assumptions made in the Qualitative Exposure Assessment regarding offsite contamination are no longer valid?

YES NO

If you answered YES to question 8, include documentation or evidence that documentation has been previously submitted with this certification form.

9. Are the assumptions in the Qualitative Exposure Assessment still valid?
(The Qualitative Exposure Assessment must be certified every five years)

If you answered NO to question 9, the Periodic Review Report must include an updated Qualitative Exposure Assessment based on the new assumptions.

SITE NO. C203041

Box 3

Description of Institutional Controls

Parcel
2408-1

Owner
Courtlandt Corners Associates LP

Institutional Control

Ground Water Use Restriction
Soil Management Plan
Building Use Restriction
Monitoring Plan
Site Management Plan
O&M Plan
IC/EC Plan

Landuse Restriction

Composite Cover, Vapor Barrier, and Sub-slab Depressurization System.
Groundwater use prohibited without treatment.
Vegetable Gardens Prohibited.
Restricted Residential, Commercial, and Industrial Use only.

Box 4

Description of Engineering Controls

Parcel
2408-1

Engineering Control
Vapor Mitigation
Cover System

Periodic Review Report (PRR) Certification Statements

1. I certify by checking "YES" below that:

a) the Periodic Review report and all attachments were prepared under the direction of, and reviewed by, the party making the Engineering Control certification;

b) to the best of my knowledge and belief, the work and conclusions described in this certification are in accordance with the requirements of the site remedial program, and generally accepted engineering practices; and the information presented is accurate and complete.

YES NO

2. For each Engineering control listed in Box 4, I certify by checking "YES" below that all of the following statements are true:

(a) The Engineering Control(s) employed at this site is unchanged since the date that the Control was put in-place, or was last approved by the Department;

(b) nothing has occurred that would impair the ability of such Control, to protect public health and the environment;

(c) access to the site will continue to be provided to the Department, to evaluate the remedy, including access to evaluate the continued maintenance of this Control;

(d) nothing has occurred that would constitute a violation or failure to comply with the Site Management Plan for this Control; and

(e) if a financial assurance mechanism is required by the oversight document for the site, the mechanism remains valid and sufficient for its intended purpose established in the document.

YES NO

IF THE ANSWER TO QUESTION 2 IS NO, sign and date below and DO NOT COMPLETE THE REST OF THIS FORM. Otherwise continue.

A Corrective Measures Work Plan must be submitted along with this form to address these issues.

 Signature of Owner, Remedial Party or Designated Representative

 Date

IC CERTIFICATIONS
SITE NO. C203041

Box 6

SITE OWNER OR DESIGNATED REPRESENTATIVE SIGNATURE

I certify that all information and statements in Boxes 1,2, and 3 are true. I understand that a false statement made herein is punishable as a Class "A" misdemeanor, pursuant to Section 210.45 of the Penal Law.

I Michael Wadman at 902 Broadway, 13th Floor, New York, NY, 10010,
print name print business address

am certifying as Owner (Owner or Remedial Party)

for the Site named in the Site Details Section of this form.

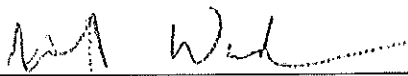

Signature of Owner, Remedial Party, or Designated Representative
Rendering Certification

5/9/2024
Date

EC CERTIFICATIONS

Box 7

Qualified Environmental Professional Signature

I certify that all information in Boxes 4 and 5 are true. I understand that a false statement made herein is punishable as a Class "A" misdemeanor, pursuant to Section 210.45 of the Penal Law.

I Jason T. Casper at CA Rich Geology Services, A.P.C., 17 Dupont St
print name print business address Plainview NY

am certifying as a Qualified Environmental Professional for Jason T. Casper (Owner or Remedial Party)

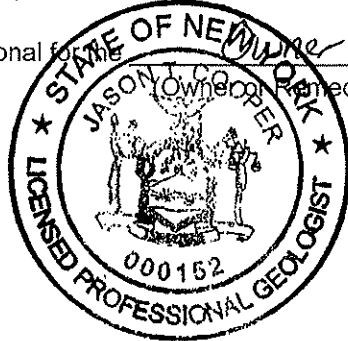

Jason T. Casper J.C.
Signature of Qualified Environmental Professional, for
the Owner or Remedial Party, Rendering Certification

Stamp
(Required for PE)

5/16/24
Date

Enclosure 3
Periodic Review Report (PRR) General Guidance

- I. Executive Summary: (1/2-page or less)
 - A. Provide a brief summary of site, nature and extent of contamination, and remedial history.
 - B. Effectiveness of the Remedial Program - Provide overall conclusions regarding:
 1. progress made during the reporting period toward meeting the remedial objectives for the site
 2. the ultimate ability of the remedial program to achieve the remedial objectives for the site.
 - C. Compliance
 1. Identify any areas of non-compliance regarding the major elements of the Site Management Plan (SMP, i.e., the Institutional/Engineering Control (IC/EC) Plan, the Monitoring Plan, and the Operation & Maintenance (O&M) Plan).
 2. Propose steps to be taken and a schedule to correct any areas of non-compliance.
 - D. Recommendations
 1. recommend whether any changes to the SMP are needed
 2. recommend any changes to the frequency for submittal of PRRs (increase, decrease)
 3. recommend whether the requirements for discontinuing site management have been met.

- II. Site Overview (one page or less)
 - A. Describe the site location, boundaries (figure), significant features, surrounding area, and the nature and extent of contamination prior to site remediation.
 - B. Describe the chronology of the main features of the remedial program for the site, the components of the selected remedy, cleanup goals, site closure criteria, and any significant changes to the selected remedy that have been made since remedy selection.

- III. Evaluate Remedy Performance, Effectiveness, and Protectiveness
Using tables, graphs, charts and bulleted text to the extent practicable, describe the effectiveness of the remedy in achieving the remedial goals for the site. Base findings, recommendations, and conclusions on objective data. Evaluations and should be presented simply and concisely.

- IV. IC/EC Plan Compliance Report (if applicable)
 - A. IC/EC Requirements and Compliance
 1. Describe each control, its objective, and how performance of the control is evaluated.
 2. Summarize the status of each goal (whether it is fully in place and its effectiveness).
 3. Corrective Measures: describe steps proposed to address any deficiencies in ICECs.
 4. Conclusions and recommendations for changes.
 - B. IC/EC Certification
 1. The certification must be complete (even if there are IC/EC deficiencies), and certified by the appropriate party as set forth in a Department-approved certification form(s).

- V. Monitoring Plan Compliance Report (if applicable)
 - A. Components of the Monitoring Plan (tabular presentations preferred) - Describe the requirements of the monitoring plan by media (i.e., soil, groundwater, sediment, etc.) and by any remedial technologies being used at the site.
 - B. Summary of Monitoring Completed During Reporting Period - Describe the monitoring tasks actually completed during this PRR reporting period. Tables and/or figures should be used to show all data.
 - C. Comparisons with Remedial Objectives - Compare the results of all monitoring with the remedial objectives for the site. Include trend analyses where possible.
 - D. Monitoring Deficiencies - Describe any ways in which monitoring did not fully comply with the monitoring plan.
 - E. Conclusions and Recommendations for Changes - Provide overall conclusions regarding the monitoring completed and the resulting evaluations regarding remedial effectiveness.

- VI. Operation & Maintenance (O&M) Plan Compliance Report (if applicable)
 - A. Components of O&M Plan - Describe the requirements of the O&M plan including required activities, frequencies, recordkeeping, etc.
 - B. Summary of O&M Completed During Reporting Period - Describe the O&M tasks actually completed during this PRR reporting period.
 - C. Evaluation of Remedial Systems - Based upon the results of the O&M activities completed, evaluated

the ability of each component of the remedy subject to O&M requirements to perform as designed/expected.

- D. O&M Deficiencies - Identify any deficiencies in complying with the O&M plan during this PRR reporting period.
- E. Conclusions and Recommendations for Improvements - Provide an overall conclusion regarding O&M for the site and identify any suggested improvements requiring changes in the O&M Plan.

VII. Overall PRR Conclusions and Recommendations

- A. Compliance with SMP - For each component of the SMP (i.e., IC/EC, monitoring, O&M), summarize;
 - 1. whether all requirements of each plan were met during the reporting period
 - 2. any requirements not met
 - 3. proposed plans and a schedule for coming into full compliance.
- B. Performance and Effectiveness of the Remedy - Based upon your evaluation of the components of the SMP, form conclusions about the performance of each component and the ability of the remedy to achieve the remedial objectives for the site.
- C. Future PRR Submittals
 - 1. Recommend, with supporting justification, whether the frequency of the submittal of PRRs should be changed (either increased or decreased).
 - 2. If the requirements for site closure have been achieved, contact the Departments Project Manager for the site to determine what, if any, additional documentation is needed to support a decision to discontinue site management.

VIII. Additional Guidance

Additional guidance regarding the preparation and submittal of an acceptable PRR can be obtained from the Departments Project Manager for the site.

APPENDIX D

Boring Logs and Well Construction Diagrams

CA RICH Consultants, Inc.

Environmental Specialists

17 Dupont Street, Plainview, NY 11803

FIELD BORING LOG

BOREHOLE NO.: **MW-1**

TOTAL DEPTH: **30 Feet**

PROJECT INFORMATION

PROJECT: **875 Melrose & 870 Courtlandt**
 SITE LOCATION: **Bronx, New York**
 JOB NO.: **Courtlandt Corners I & II**
 LOGGED BY: **Jason Cooper**
 PROJECT MANAGER: **Deborah Shapiro**
 DATES DRILLED: **3/28/2012**

DRILLING INFORMATION

DRILLING CO.: **AARCO**
 DRILLER: **John**
 RIG TYPE: **Truck mounted drill rig**
 METHOD OF DRILLING: **Hollow stem augers**
 SAMPLING METHODS: **Drill cuttings**
 HAMMER WT./DROP: **N/A**

∇ Approximate Water Level

DEPTH (FEET)	SOIL TYPE	SOIL DESCRIPTION	SAMPLE NUMBER	Blows per ft.	PID ppm	MONITORING WELL CONSTRUCTION	WELL DESCRIPTION
0		Concrete	NA	NA			Cover
0 - 5		Brown medium sand with pebbles					Bentonite Seal
5 - 27		No drill cuttings			0.0		Sch. 40 PVC Riser- 0-5 feet
27 - 30		Brown medium sand with silt			0.0		No. 2 Sand
							20 Slot Screen- 5-25 feet

NOTES: Well was developed on March 28, 2012 using a surge block and check valve.

Page 1 of 1

Approximately 20 gallons of water was purged from well to obtain clear water.

CA RICH Consultants, Inc.

Environmental Specialists

17 Dupont Street, Plainview, NY 11803

FIELD BORING LOG

BOREHOLE NO.: **MW-2**

TOTAL DEPTH: **30 Feet**

PROJECT INFORMATION

PROJECT: **875 Melrose & 870 Courtlandt**
 SITE LOCATION: **Bronx, New York**
 JOB NO.: **Courtlandt Corners I & II**
 LOGGED BY: **Jason Cooper**
 PROJECT MANAGER: **Deborah Shapiro**
 DATES DRILLED: **3/26/2012**

DRILLING INFORMATION

DRILLING CO.: **AARCO**
 DRILLER: **John**
 RIG TYPE: **Truck mounted drill rig**
 METHOD OF DRILLING: **Hollow stem augers**
 SAMPLING METHODS: **Drill cuttings**
 HAMMER WT./DROP: **N/A**

∞ Approximate Water Level

DEPTH (FEET)	SOIL TYPE	SOIL DESCRIPTION	SAMPLE NUMBER	Blows per ft.	PID ppm	MONITORING WELL CONSTRUCTION	WELL DESCRIPTION
0		Concrete	NA	NA			Cover
0 - 5		Brown medium sand with pebbles					Bentonite Seal
5 - 27		No drill cuttings			0.0		Sch. 40 PVC Riser- 0-5 feet
27 - 30		Gray silt with fine grain sand			6.0		No. 2 Sand
							20 Slot Screen- 5-25 feet

NOTES: Well was developed on March 28, 2012 using a surge block and check valve.

Page 1 of 1

Approximately 22 gallons of water was purged from well to obtain clear water.

CA RICH Consultants, Inc.

Environmental Specialists

17 Dupont Street, Plainview, NY 11803

FIELD BORING LOG

BOREHOLE NO.: **MW-3**

TOTAL DEPTH: **28 Feet**

PROJECT INFORMATION

PROJECT: **875 Melrose & 870 Courtlandt**
 SITE LOCATION: **Bronx, New York**
 JOB NO.: **Courtlandt Corners I & II**
 LOGGED BY: **Jason Cooper**
 PROJECT MANAGER: **Deborah Shapiro**
 DATES DRILLED: **3/26/2012**

DRILLING INFORMATION

DRILLING CO.: **AARCO**
 DRILLER: **John**
 RIG TYPE: **Truck mounted drill rig**
 METHOD OF DRILLING: **Hollow stem augers**
 SAMPLING METHODS: **Drill cuttings**
 HAMMER WT./DROP: **N/A**

∞ Approximate Water Level

DEPTH (FEET)	SOIL TYPE	SOIL DESCRIPTION	SAMPLE NUMBER	Blows per ft.	PID ppm	MONITORING WELL CONSTRUCTION	WELL DESCRIPTION
0		Concrete	NA	NA			Cover
0 - 5		Brown medium sand with pebbles			0.0		Bentonite Seal
5 - 25		No drill cuttings					Sch. 40 PVC Riser- 0-5 feet
25 - 28		Gray silt with little clay			0.0		No. 2 Sand
							20 Slot Screen- 5-25 feet

NOTES: Well was developed on March 28, 2012 using a surge block and check valve.

Page 1 of 1

Approximately 25 gallons of water was purged from well to obtain clear water.

CA RICH Consultants, Inc.

Environmental Specialists

17 Dupont Street, Plainview, NY 11803

FIELD BORING LOG

BOREHOLE NO.: **MW-4**

TOTAL DEPTH: **30 Feet**

PROJECT INFORMATION

PROJECT: **875 Melrose & 870 Courtlandt**
 SITE LOCATION: **Bronx, New York**
 JOB NO.: **Courtlandt Corners I & II**
 LOGGED BY: **Jason Cooper**
 PROJECT MANAGER: **Deborah Shapiro**
 DATES DRILLED: **3/28/2012**

DRILLING INFORMATION

DRILLING CO.: **AARCO**
 DRILLER: **John**
 RIG TYPE: **Truck mounted drill rig**
 METHOD OF DRILLING: **Hollow stem augers**
 SAMPLING METHODS: **Drill cuttings**
 HAMMER WT./DROP: **N/A**

∇ Approximate Water Level

DEPTH (FEET)	SOIL TYPE	SOIL DESCRIPTION	SAMPLE NUMBER	Blows per ft.	PID ppm	MONITORING WELL CONSTRUCTION	WELL DESCRIPTION
0		Concrete	NA	NA			Cover
0 - 5		Brown medium sand with pebbles			0.0		Bentonite Seal Sch. 40 PVC Riser- 0-5 feet
5 - 25		No drill cuttings					No. 2 Sand 20 Slot Screen- 5-25 feet
25 - 30		Brown medium grain sand and silt			0.0		

NOTES: Well was developed on March 28, 2012 using a surge block and check valve.

Page 1 of 1

Approximately 25 gallons of water was purged from well to obtain clear water.

CA RICH Consultants, Inc.

Environmental Specialists

17 Dupont Street, Plainview, NY 11803

FIELD BORING LOG

BOREHOLE NO.: **MW-5**

TOTAL DEPTH: **30 Feet**

PROJECT INFORMATION

PROJECT: **875 Melrose & 870 Courtlandt**
 SITE LOCATION: **Bronx, New York**
 JOB NO.: **Courtlandt Corners I & II**
 LOGGED BY: **Jason Cooper**
 PROJECT MANAGER: **Deborah Shapiro**
 DATES DRILLED: **3/27/2012**

DRILLING INFORMATION

DRILLING CO.: **AARCO**
 DRILLER: **John**
 RIG TYPE: **Truck mounted drill rig**
 METHOD OF DRILLING: **Hollow stem augers**
 SAMPLING METHODS: **Drill cuttings**
 HAMMER WT./DROP: **N/A**

∞ Approximate Water Level

DEPTH (FEET)	SOIL TYPE	SOIL DESCRIPTION	SAMPLE NUMBER	Blows per ft.	PID ppm	MONITORING WELL CONSTRUCTION	WELL DESCRIPTION
0		Concrete	NA	NA			Cover
0 - 5		Brown medium sand with pebbles					Bentonite Seal
5 - 25		No drill cuttings			0.0		Sch. 40 PVC Riser- 0-5 feet
25 - 30		Gray silt with fine grain sand			5.0		No. 2 Sand
							20 Slot Screen- 5-25 feet

NOTES: Well was developed on March 28, 2012 using a surge block and check valve.

Page 1 of 1

Approximately 25 gallons of water was purged from well to obtain clear water.

CA RICH Consultants, Inc.

Environmental Specialists

17 Dupont Street, Plainview, NY 11803

FIELD BORING LOG

BOREHOLE NO.: **MW-6**

TOTAL DEPTH: **30 Feet**

PROJECT INFORMATION

PROJECT: **875 Melrose & 870 Courtlandt**
 SITE LOCATION: **Bronx, New York**
 JOB NO.: **Courtlandt Corners I & II**
 LOGGED BY: **Jason Cooper**
 PROJECT MANAGER: **Deborah Shapiro**
 DATES DRILLED: **3/27/2012**

DRILLING INFORMATION

DRILLING CO.: **AARCO**
 DRILLER: **John**
 RIG TYPE: **Truck mounted drill rig**
 METHOD OF DRILLING: **Hollow stem augers**
 SAMPLING METHODS: **Drill cuttings**
 HAMMER WT./DROP: **N/A**

∞ Approximate Water Level

DEPTH (FEET)	SOIL TYPE	SOIL DESCRIPTION	SAMPLE NUMBER	Blows per ft.	PID ppm	MONITORING WELL CONSTRUCTION	WELL DESCRIPTION
0		Concrete	NA	NA			Cover
0 - 5		Brown medium grain sand			0.0		Bentonite Seal Sch. 40 PVC Riser- 0-5 feet
5 - 25		No drill cuttings					No. 2 Sand 20 Slot Screen- 5-25 feet
25 - 30		Brown silty sand Gray clay on auger flights at the 20-30 Feet interval			0.0		

NOTES: Well was developed on March 28, 2012 using a surge block and check valve.
 Approximately 5 gallons of water were purged from well until it went dry.

APPENDIX E

O&M Checklist

**Operation and Maintenance Check List
Sub-Slab Depressurization System
Courtlandt Corners II
875 Melrose Avenue
Bronx, New York
BCP #C203041**

Name: Jason Cooper	Weather: Cloudy 55 F					
Components to be Checked	Date: 5/4/2023	Date:	Date:	Date:	Date:	Date:
Is the system operating? Yes/No (if no please explain)	Yes					
Record the vacuum from each riser. in the basement storage room (C-08) (Vents A,B,C, D) Vacuum is in inches of water Room C-08	A: -0.083 B: -0.064 C: -0.058 D: -0.043 Main Pipe Basement: -0.240 Roof: -0.75					
Record PID reading from each riser. (Vents A,B,C, D) (Storage Room)	A: 0.0 ppm B: 0.0 ppm C: 0.0 ppm D: 0.0 ppm Main Pipe basement: 0.0 ppm Roof: 0.0 ppm					
Pressure gauge and exterior case clear? Yes/No (if no please explain) (Vents A,B,C,D in Basement) Pressure is in inches of water	A: Good/clear B: Good/clear C: Good/clear D: Good/clear Main Pipe basement: Good/clear Roof: Good/clear					
Red light	Working: Yes properly and was tested.					
<i>Additional comments:</i>						
Inspector: Jason Cooper Date/Time: May 4, 2023 12PM						

APPENDIX F

Photohelic® Details and Red Light



Dwyer INSTRUMENTS, INC



Cart



Quick Order/Quote



Log In/Register

Digital
Catalog

RIGHT CHOICE. RIGHT PRICE. RIGHT NOW.

800/872-9141 • 219/879-8000

SEARCH

Series

Products

Catalog

News

About Us

Contact Us

Video Library

Home

You Are Here: [Pressure](#) > [Differential Pressure](#) > [Gage / Switches - Dial](#) > [Series A3000](#)



Series A3000

Photohelic® Pressure Switch/Gage

3-in-1 Indicating Gage, Lo-limit and Hi-limit Control



Product Introduction

Photohelic® Switch/Gages function as versatile, highly repeatable pressure switches combined with a precise pressure gage employing the time-proven Magnehelic® gage design. The Photohelic® switch/gage measures and controls positive, negative or differential pressures of air and compatible gases. Standard models are rated to 25 psig (1.7 bar) with options to 35 (2.4) or 80 (5.5 bar) psig. Single pressure 36000S models measure to 6000 psig (413 bar) with a 9000 psig (620 bar) rating. Two phototransistor actuated, DPDT relays are included for low/high limit control. Easy to adjust set point indicators are controlled by knobs located on the gage face. Individual set point deadband is one pointer width - less than 1% of full scale. Set points can be interlocked to provide variable deadband - ideal for control of fans, dampers, etc. Gage reading is continuous and unaffected by switch operation, even during loss of electrical power. Choose from full scale pressure ranges from a low 0-.25" (0-6 mm) w.c. up to 30 psi (21 bar); single positive pressure to 6000 psig (413 bar).

Photohelic Sensing - How It Works

In typical applications, these Dwyer switch/gages control between high and low pressure set points. When pressure changes, reaching either set point pressure, the infrared light to the limiting phototransistor is cut off by the helix-driven light shutter. The resulting phototransistor signal is electronically amplified to actuate its DPDT slave relay and switching occurs. Dead band between make and break is 1% of full scale or less - just enough to assure positive, chatter-free operation.

Relay-Transformer Features

A plastic housing protects all electronic components. Solid-state and integrated circuit electronics are on glass-epoxy printed circuit boards and self-extinguishing terminal boards.

Product Details

Pricing / Ordering
Introduction
Specifications
Options/Accessories
Features
Applications
Approvals
Model Chart
Service Manuals
Dimensional Drawings
Catalog Pages
Related Products
Air Velocity and Flow
Calculator



About SSL Certificates

[Home](#)[Free Literature](#)[International Distribution](#)[What's New](#)[About Us](#)[Careers](#)[Contact Us](#)[Terms & Conditions of Sale](#)[Terms of Access](#)

© Copyright 2012 Dwyer Instruments, Inc. All rights reserved.

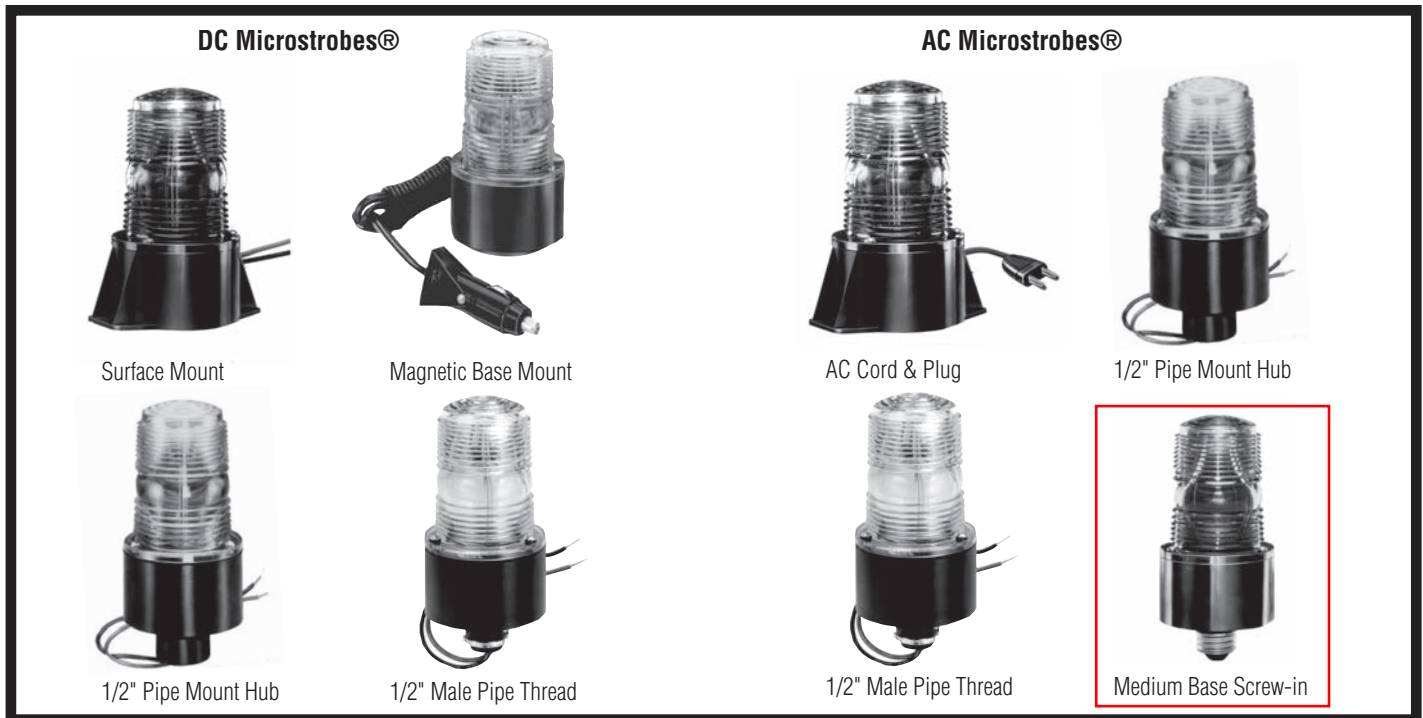

FORK TRUCK STROBES - DC Models

The MICROSTROBE® IV strobe family is an enhanced version of the MICRO III featuring a new screw-on 100% water-tight lens and power supply which can operate from a very wide input voltage range of 12 through 80 VDC or 16 through 24 VAC. The supply has a regulated output so that the lamp brightness and flash rate remain constant over the entire input voltage range. The power supply is potted in polyurethane for the ultimate in protection from shock and vibration. The enclosure is 100% Lexan Type 4X, and the plug-in strobe lamp is field replaceable. All units are polarity protected and have built-in filters to protect against radio interference and spike voltages. The MICROSTROBE® IV is protected with a **TEN YEAR WARRANTY**. See opposite page.

SPECIFICATIONS

• Intensity

CLEAR	50 Candela
AMBER	40 Candela
BLUE	20 Candela
RED	10 Candela
GREEN	20 Candela

- 1.75 Joules per flash, power supply output 2.7 Watts
- 60 to 80 flashes per minute
- UL component listed, type E, ES & EE Electric Trucks
- 5" Tall X 3" Dia., 0.6 lbs.

470S-1280	Surface Mount
470SMB-1280	Magnetic Mount with 6 ft. cord & cigar plug.
490S-1280	1/2" Pipe Mount Hub
495S-1280	1/2" Male Pipe Thread
470SMB-1280/CC	Magnetic Mount w/ 10' coiled cord & cigar plug

Options & Parts

G470	Guard
5001	Flashtube
470S-L	Lexan Lens
BKT	L Mounting Bracket
LBO	180 Degree lens black out (NC if ordered with unit)

MICROSTROBES® - AC Models

For general purpose visible signals the versatile MICROSTROBE® does it all. Choose from several mounting styles - even a medium base light bulb socket power supplies with screw-on Lexan lenses, creating a 100% water-tight Type 4X enclosure.

Application Note for 120 VAC Units

120 VAC units that are going to be switched on-off with a solid state relay should be ordered with option **/TRIAC-SW** to prevent false operation from snubber leakage current.

SPECIFICATIONS

• Intensity

CLEAR	50 Candela
AMBER	40 Candela
BLUE	20 Candela
RED	10 Candela
GREEN	20 Candela

- 1.75 Joules per flash, power supply output 2.7 Watts
- 60 to 80 flashes per minute, -40F to +150F Temperature Range
- All models UL Listed
- Low power consumption 0.04 amps @ 120 VAC
- 5" tall X 3" Dia., 0.6 lbs.

480S-120	AC Cord & Plug Surface Mount
490S-120	1/2" Pipe Mount Hub
495S-120	1/2" Male Pipe Thread
485S-120	Medium Base Socket Screw-in
470SSGP-120	Wall Plate Mount (not shown)
490S-240	240 AC 1/2" Pipe Mount
495S-240	240 AC Male Pipe Thread
485S-240	240 AC Medium Base Mount

Options & Parts

G470	Guard
5001	Flashtube
470S-L	Lexan Lens
/TRIAC-SW	Leakage current bypass

APPENDIX G

Fantech Model HP220 Specifications



Fantech

Installation Instructions for Radon Fans Model HP/FR

READ & SAVE THESE INSTRUCTIONS!



Warnings

DO NOT CONNECT POWER SUPPLY UNTIL FAN IS COMPLETELY INSTALLED, MAKE SURE ELECTRICAL SERVICE TO THE FAN IS LOCKED IN "OFF" POSITION.

1. Suitable for use with solid-state speed control.
2. This unit has rotating parts and safety precautions should be exercised during installation, operation and maintenance.
3. CAUTION: "For General Ventilation Use Only. Do Not Use To Exhaust Hazardous Or Explosives Materials and Vapors."
4. **WARNING: TO REDUCE THE RISK OF FIRE, ELECTRIC SHOCK, OR INJURY TO PERSONS-OBSERVE THE FOLLOWING:**
 - a. Use this unit only in the manner intended by the manufacturer. If you have questions, contact the factory.
 - b. Before servicing or cleaning unit, switch power off at service panel and lock the service disconnecting means to prevent power from being switched on accidentally. When the service disconnecting means cannot be locked, securely fasten a prominent warning device, such as a tag, to the service panel.
 - c. Installation work and electrical wiring must be done by qualified person(s) in accordance with all applicable codes and standards, including fire-rated construction.
 - d. The combustion airflow needed for safe operation of fuel burning equipment may be affected by this unit's operation. Follow the heating equipment manufacturer's guidelines and safety standards such as those published by the National Fire Protection Association (NFPA), the American Society of Heating, Refrigeration, and Air Conditioning Engineers (ASHRAE) and the local code authorities.
 - e. When cutting or drilling into wall or ceiling, do not damage electrical wires or other hidden utilities.
 - f. Ducted fans must always be vented to the outdoors.
 - g. If this unit is to be installed over a tub or shower, it must be marked as appropriate for the application.
 - h. NEVER place a switch where it can be reached from a tub or shower.
5. **WARNING!** Check voltage at the fan to see if it corresponds to the motor nameplate.

GUARDS MUST BE INSTALLED WHEN FAN IS WITHIN REACH OF PERSONNEL OR WITHIN SEVEN (7) FEET OF WORKING LEVEL OR WHEN DEEMED ADVISABLE FOR SAFETY.

Wiring Diagram

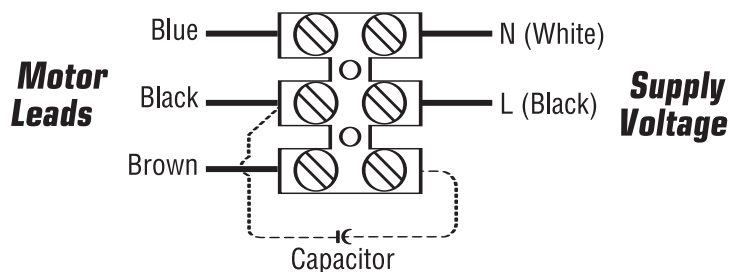

Five (5) Year Warranty

This warranty supersedes all prior warranties

Installation that will result in condensate forming in the outlet ducting should have a condensate bypass installed to route the condensate outside of the fan housing. Conditions that are likely to produce condensate include but are not limited to: outdoor installations in cold climates, long lengths of outlet ducting, high moisture content in soil and thin wall or aluminum outlet ducting. Failure to install a proper condensate bypass may void any warranty claims.

DURING ENTIRE WARRANTY PERIOD:

FANTECH will repair or replace any part which has a factory defect in workmanship or material. Product may need to be returned to the fan-tech factory, together with a copy of the bill of sale and identified with RMA number.

FOR FACTORY RETURN YOU MUST:

- Have a Return Materials Authorization (RMA) number. This may be obtained by calling FANTECH either in the USA at 1.800.747.1762 or in CANADA at 1.800.565.3548. Please have bill of sale available.
- The RMA number must be clearly written on the outside of the carton, or the carton will be refused.
- All parts and/or product will be repaired/replaced and shipped back to buyer; no credit will be issued.

OR

The Distributor may place an order for the warranty part and/or product and is invoiced. The Distributor will receive a credit equal to the invoice only after product is returned prepaid and verified to be defective.

FANTECH WARRANTY TERMS DO NOT PROVIDE FOR REPLACEMENT WITHOUT CHARGE PRIOR TO INSPECTION FOR A DEFECT. REPLACEMENTS ISSUED IN ADVANCE OF DEFECT INSPECTION ARE INVOICED, AND CREDIT IS PENDING INSPECTION OF RETURNED MATERIAL. DEFECTIVE MATERIAL RETURNED BY END USERS SHOULD NOT BE REPLACED BY THE DISTRIBUTOR WITHOUT CHARGE TO THE END USER, AS CREDIT TO DISTRIBUTOR'S ACCOUNT WILL BE PENDING INSPECTION AND VERIFICATION OF ACTUAL DEFECT BY FANTECH.

THE FOLLOWING WARRANTIES DO NOT APPLY:

- Damages from shipping, either concealed or visible. Claim must be filed with freight company.
- Damages resulting from improper wiring or installation.
- Damages or failure caused by acts of God, or resulting from improper consumer procedures, such as:
 1. Improper maintenance
 2. Misuse, abuse, abnormal use, or accident, and
 3. Incorrect electrical voltage or current.
- Removal or any alteration made on the FANTECH label control number or date of manufacture.
- Any other warranty, expressed, implied or written, and to any consequential or incidental damages, loss or property, revenues, or profit, or costs of removal, installation or reinstallation, for any breach of warranty.

WARRANTY VALIDATION

- The user must keep a copy of the bill of sale to verify purchase date.
- These warranties give you specific legal rights, and are subject to an applicable consumer protection legislation. You may have additional rights which vary from state to state.

United States

1712 Northgate Blvd.,
Sarasota, FL. 34234
Phone: 800.747.1762; 941.309.6000
Fax: 800.487.9915; 941.309.6099
www.fantech.net; info@fantech.net

Canada

50 Kanalfakt Way,
Bouctouche, NB E4S 3M5
Phone: 800.565.3548; 506.743.9500
Fax: 877.747.8116; 506.743.9600
www.fantech.ca; info@fantech.ca

Fantech, reserves the right to modify, at any time and without notice, any or all of its products' features, designs, components and specifications to maintain their technological leadership position.

Article #: 301077
Item #: 401443
Rev Date: 010307

APPENDIX H

Mitigation System Installation Record

Mitigation System Installation Record

Structure was sampled previously

System Information

System ID: Site No: C203041
Owner Name: Courtlandt Corners II Associates LLC Owner Occupied
System Address: 875 Melrose Ave Telephone: _____
City: Bronx Zip: 10451 Alt. Telephone: _____

Contractor Information

Installer Name: Fred Demnus Company: Melco Plumbing
Telephone: 718-939-8100

Building Conditions

Building Type:

Slab Integrity: Poor Average Good Excellent
Slab Penetrations: Sump Floor drain Perimeter drain Other

Describe:

Observed Water: Dry Damp Sump only Standing

Describe:

System Installation

Installation Type: Date Installed: Aug 2008-Dec 2010

Slab Thickness (inches):

Subslab Material:

Subslab Moisture:

Number of Suction Points:

Number of Fans Installed:

Fan #1 Operating Fan #2 Operating Fan #3 Operating

Fan Model No(s): Fantech HP220 _____

Fan Serial No(s): _____

Final U-Tube Levels: _____

Additional Mitigation Elements (check all that apply):

Drainer Membrane Sealed cracks New floor Rain cap Other

Comments:

Communication Testing

Test Method:

Meter Type/Manufacturer: _____

Location	Reading/Result	Dist. From Suction Point (ft)	Passed?
Vent A	-0.105" H2O		<input checked="" type="checkbox"/>
Vent B	-0.081		<input checked="" type="checkbox"/>
Vent C	-0.067		<input checked="" type="checkbox"/>
Vent D	-0.063		<input checked="" type="checkbox"/>
Fan #1	-0.75		<input checked="" type="checkbox"/>

NORTH	System Sketch (indicate notable features, location of extraction points, and communication test holes)

APPENDIX I

Environmental Easement

**NYC DEPARTMENT OF FINANCE
OFFICE OF THE CITY REGISTER**

This page is part of the instrument. The City Register will rely on the information provided by you on this page for purposes of indexing this instrument. The information on this page will control for indexing purposes in the event of any conflict with the rest of the document.

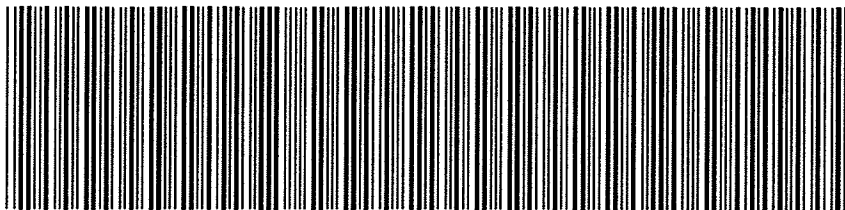

2010091300801001002E0D9B

RECORDING AND ENDORSEMENT COVER PAGE

PAGE 1 OF 12

Document ID: 2010091300801001 Document Date: 09-09-2010 Preparation Date: 09-13-2010
Document Type: EASEMENT
Document Page Count: 10

PRESENTER:
TITLEASSOCIATES - PICK-UP/ TA#10-02-180B
AS AGENT FOR STEWART TITLE
825 THIRD AVENUE - 30TH FLOOR
NEW YORK, NY 10022
212-758-0050
jfeldman@titleassociates.com

RETURN TO:
RUSSELL KIVLER, ESQ
HIRSCHEN SINGER & EPSTEIN LLP
902 BROADWAY
NEW YORK, NY 10010

PROPERTY DATA

Borough	Block	Lot	Unit	Address
BRONX	2408	1	Entire Lot	361 EAST 161 STREET

Property Type: COMMERCIAL REAL ESTATE Easement

CROSS REFERENCE DATA

CRFN _____ or Document ID _____ or _____ Year _____ Reel _____ Page _____ or File Number _____

PARTIES

GRANTOR/SELLER:
COURTLANDT CORNERS II HOUSING
DEVELOPMENT FUND COR
902 BROADWAY, 13 FLOOR.
NEWYORK, NY 10010
x Additional Parties Listed on Continuation Page

GRANTEE/BUYER:
NEW YORK STATE DEPARTMENT OF
ENVIRONMENTAL CONSERV
625 BROADWAY
ALBANY, NY 12233-1500

FEES AND TAXES

Mortgage	
Mortgage Amount:	\$ 0.00
Taxable Mortgage Amount:	\$ 0.00
Exemption:	
TAXES: County (Basic):	\$ 0.00
City (Additional):	\$ 0.00
Spec (Additional):	\$ 0.00
TASF:	\$ 0.00
MTA:	\$ 0.00
NYCTA:	\$ 0.00
Additional MRT:	\$ 0.00
TOTAL:	\$ 0.00
Recording Fee:	\$ 87.00
Affidavit Fee:	\$ 0.00

Filing Fee:	\$ 250.00
NYC Real Property Transfer Tax:	\$ 0.00
NYS Real Estate Transfer Tax:	\$ 0.00



**RECORDED OR FILED IN THE OFFICE
OF THE CITY REGISTER OF THE
CITY OF NEW YORK**

Recorded/Filed 09-14-2010 16:31
City Register File No.(CRFN):
2010000310267

Annette M Hill

City Register Official Signature

**NYC DEPARTMENT OF FINANCE
OFFICE OF THE CITY REGISTER**

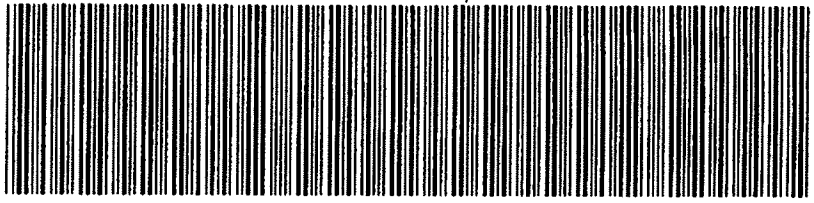

2010091300801001002C0F1B

RECORDING AND ENDORSEMENT COVER PAGE (CONTINUATION) PAGE 2 OF 12

Document ID: 2010091300801001
Document Type: EASEMENT

Document Date: 09-09-2010

Preparation Date: 09-13-2010

PARTIES

GRANTOR/SELLER:

COURTLANDT CORNERS II ASSOCIATES, L.P.
902 BROADWAY, 13TH FLOOR
NEWYORK, NY 10010

**ENVIRONMENTAL EASEMENT GRANTED PURSUANT TO ARTICLE 71, TITLE 36
OF THE NEW YORK STATE ENVIRONMENTAL CONSERVATION LAW**

THIS INDENTURE made this 1st day of September, 2010, between Owner(s) Courtlandt Corners II Housing Development Fund Corporation (Fee) and Courtlandt Corners II Associates, L.P. (Beneficial Interest), having an office at 902 Broadway, 13th Floor, New York, New York 10010, Bronx County, State of New York (collectively the "Grantor"), and The People of the State of New York (the "Grantee."), acting through their Commissioner of the Department of Environmental Conservation (the "Commissioner", or "NYSDEC" or "Department" as the context requires) with its headquarters located at 625 Broadway, Albany, New York 12233,

WHEREAS, the Legislature of the State of New York has declared that it is in the public interest to encourage the remediation of abandoned and likely contaminated properties ("sites") that threaten the health and vitality of the communities they burden while at the same time ensuring the protection of public health and the environment; and

WHEREAS, the Legislature of the State of New York has declared that it is in the public interest to establish within the Department a statutory environmental remediation program that includes the use of Environmental Easements as an enforceable means of ensuring the performance of operation, maintenance, and/or monitoring requirements and the restriction of future uses of the land, when an environmental remediation project leaves residual contamination at levels that have been determined to be safe for a specific use, but not all uses, or which includes engineered structures that must be maintained or protected against damage to perform properly and be effective, or which requires groundwater use or soil management restrictions; and

WHEREAS, the Legislature of the State of New York has declared that Environmental Easement shall mean an interest in real property, created under and subject to the provisions of Article 71, Title 36 of the New York State Environmental Conservation Law ("ECL") which contains a use restriction and/or a prohibition on the use of land in a manner inconsistent with engineering controls which are intended to ensure the long term effectiveness of a site remedial program or eliminate potential exposure pathways to hazardous waste or petroleum; and

WHEREAS, Grantor, is the owner of real property located at the address of 890 Courtlandt Avenue ; 370 East 162nd Street; 380 East 162nd Street; 875 Melrose Avenue; and 361, 371, 375, 381 East 161st Street in the City of New York, County of Bronx and State of New York, known and designated on the tax map of the County Clerk of Bronx as tax map parcel numbers: Section 9 Block 2408 Lot 1 (former Lot 20), being the same as that property conveyed to Grantor by deed dated June 30, 2008 and recorded in the office of the City Register of the City of New York in Instrument No. or CRFN No. 2009000002551 and by Declaration and Nominee Agreement dated June 30, 2008 recorded July 25, 2008 in CRFN 2008-000-295946 comprising approximately 0.16 ± acres, and hereinafter more fully described in the Land Title Survey dated July 30, 2007 and revised August 30, 2010 prepared by True North Surveyors, P.C. which will be attached to the Site Management Plan. The property description (the "Controlled Property") is set forth in and attached hereto as Schedule A; and

WHEREAS, the Department accepts this Environmental Easement in order to ensure the protection of human health and the environment and to achieve the requirements for remediation

established for the Controlled Property until such time as this Environmental Easement is extinguished pursuant to ECL Article 71, Title 36; and

NOW THEREFORE, in consideration of the mutual covenants contained herein and the terms and conditions of BCA Index No. A2- 0593- 0707, Grantor conveys to Grantee a permanent Environmental Easement pursuant to ECL Article 71, Title 36 in, on, over, under, and upon the Controlled Property as more-fully described herein ("Environmental Easement")

1. **Purposes.** Grantor and Grantee acknowledge that the Purposes of this Environmental Easement are: to convey to Grantee real property rights and interests that will run with the land in perpetuity in order to provide an effective and enforceable means of encouraging the reuse and redevelopment of this Controlled Property at a level that has been determined to be safe for a specific use while ensuring the performance of operation, maintenance, and/or monitoring requirements; and to ensure the restriction of future uses of the land that are inconsistent with the above-stated purpose.

2. **Institutional and Engineering Controls.** The controls and requirements listed in the Department approved Site Management Plan ("SMP") including any and all Department approved amendments to the SMP are incorporated into and made part of this Environmental Easement. These controls and requirements apply to the use of the Controlled Property, run with the land, are binding on the Grantor and the Grantor's successors and assigns, and are enforceable in law or equity against any owner of the Controlled Property, any lessees and any person using the Controlled Property.

A. (1) The Controlled Property may be used for:

**Restricted Residential as described in 6 NYCRR Part 375-1.8(g)(2)(ii),
Commercial as described in 6 NYCRR Part 375-1.8(g)(2)(iii) and Industrial
as described in 6 NYCRR Part 375-1.8(g)(2)(iv)**

(2) All Engineering Controls must be operated and maintained as specified in the Site Management Plan (SMP);

(3) All Engineering Controls must be inspected at a frequency and in a manner defined in the SMP.

(4) Groundwater and other environmental or public health monitoring must be performed as defined in the SMP;

(5) Data and information pertinent to Site Management of the Controlled Property must be reported at the frequency and in a manner defined in the SMP;

(6) All future activities on the property that will disturb remaining contaminated material must be conducted in accordance with the SMP;

(7) Monitoring to assess the performance and effectiveness of the remedy must be performed as defined in the SMP.

(8) Operation, maintenance, monitoring, inspection, and reporting of any mechanical or physical components of the remedy shall be performed as defined in the SMP.

(9) Access to the site must be provided to agents, employees or other representatives of the State of New York with reasonable prior notice to the property owner to assure compliance with the restrictions identified by this Environmental Easement.

B. The Controlled Property shall not be used for raising livestock or producing animal products for human consumption, and the above-stated engineering controls may not be discontinued without an amendment or extinguishment of this Environmental Easement.

C. The SMP describes obligations that the Grantor assumes on behalf of Grantor, its successors and assigns. The Grantor's assumption of the obligations contained in the SMP which may include sampling, monitoring, and/or operating a treatment system, and providing certified reports to the NYSDEC, is and remains a fundamental element of the Department's determination that the Controlled Property is safe for a specific use, but not all uses. The SMP may be modified in accordance with the Department's statutory and regulatory authority. The Grantor and all successors and assigns, assume the burden of complying with the SMP and obtaining an up-to-date version of the SMP from:

Regional Remediation Engineer
NYSDEC - Region 2
Division of Environmental Remediation
One Hunter's Point Plaza, 47- 40 21st Street
Long Island City, NY 11101-5407,
Phone: (718) 482 - 4900

or

Site Control Section
Division of Environmental Remediation
NYSDEC
625 Broadway
Albany, New York 12233
Phone: (518) 402-9553

D. Grantor must provide all persons who acquire any interest in the Controlled Property a true and complete copy of the SMP that the Department approves for the Controlled Property and all Department-approved amendments to that SMP.

E. Grantor covenants and agrees that until such time as the Environmental Easement is extinguished in accordance with the requirements of ECL Article 71, Title 36 of the ECL, the property deed and all subsequent instruments of conveyance relating to the Controlled Property shall state in at least fifteen-point bold-faced type:

This property is subject to an Environmental Easement held by the New York State Department of Environmental

Conservation pursuant to Title 36 of Article 71 of the Environmental Conservation Law.

F. Grantor covenants and agrees that this Environmental Easement shall be incorporated in full or by reference in any leases, licenses, or other instruments granting a right to use the Controlled Property.

G. Grantor covenants and agrees that it shall annually, or such time as NYSDEC may allow, submit to NYSDEC a written statement by an expert the NYSDEC may find acceptable certifying under penalty of perjury, in such form and manner as the Department may require, that:

(1) the inspection of the site to confirm the effectiveness of the institutional and engineering controls required by the remedial program was performed under the direction of the individual set forth at 6 NYCRR Part 375-1.8(h)(3).

(2) the institutional controls and/or engineering controls employed at such site:
(i) are in-place;
(ii) are unchanged from the previous certification, or that any identified changes to the controls employed were approved by the NYSDEC and that all controls are in the Department-approved format; and

(iii) that nothing has occurred that would impair the ability of such control to protect the public health and environment;

(3) the owner will continue to allow access to such real property to evaluate the continued maintenance of such controls;

(4) nothing has occurred that would constitute a violation or failure to comply with any site management plan for such controls;

(5) the report and all attachments were prepared under the direction of, and reviewed by, the party making the certification;

(6) to the best of his/her knowledge and belief, the work and conclusions described in this certification are in accordance with the requirements of the site remedial program, and generally accepted engineering practices; and

(7) the information presented is accurate and complete.

3. Right to Enter and Inspect. Grantee, its agents, employees, or other representatives of the State may enter and inspect the Controlled Property in a reasonable manner and at reasonable times to assure compliance with the above-stated restrictions.

4. Reserved Grantor's Rights. Grantor reserves for itself, its assigns, representatives, and successors in interest with respect to the Property, all rights as fee owner of the Property, including:

A. Use of the Controlled Property for all purposes not inconsistent with, or limited by the terms of this Environmental Easement;

B. The right to give, sell, assign, or otherwise transfer part or all of the underlying fee interest to the Controlled Property, subject and subordinate to this Environmental Easement;

5. Enforcement

A. This Environmental Easement is enforceable in law or equity in perpetuity by Grantor, Grantee, or any affected local government, as defined in ECL Section 71-3603, against the owner of the Property, any lessees, and any person using the land. Enforcement shall not be defeated because of any subsequent adverse possession, laches, estoppel, or waiver. It is not a defense in any action to enforce this Environmental Easement that: it is not appurtenant to an interest in real property; it is not of a character that has been recognized traditionally at common law; it imposes a negative burden; it imposes affirmative obligations upon the owner of any interest in the burdened property; the benefit does not touch or concern real property; there is no privity of estate or of contract; or it imposes an unreasonable restraint on alienation.

B. If any person violates this Environmental Easement, the Grantee may revoke the Certificate of Completion with respect to the Controlled Property.

C. Grantee shall notify Grantor of a breach or suspected breach of any of the terms of this Environmental Easement. Such notice shall set forth how Grantor can cure such breach or suspected breach and give Grantor a reasonable amount of time from the date of receipt of notice in which to cure. At the expiration of such period of time to cure, or any extensions granted by Grantee, the Grantee shall notify Grantor of any failure to adequately cure the breach or suspected breach, and Grantee may take any other appropriate action reasonably necessary to remedy any breach of this Environmental Easement, including the commencement of any proceedings in accordance with applicable law.

D. The failure of Grantee to enforce any of the terms contained herein shall not be deemed a waiver of any such term nor bar any enforcement rights.

6. Notice. Whenever notice to the Grantee (other than the annual certification) or approval from the Grantee is required, the Party providing such notice or seeking such approval shall identify the Controlled Property by referencing the following information:

County, NYSDEC Site Number, NYSDEC Brownfield Cleanup Agreement, State Assistance Contract or Order Number, and the County tax map number or the Liber and Page or computerized system identification number.

Parties shall address correspondence to: Site Number: C 203041
Office of General Counsel
NYSDEC
625 Broadway
Albany New York 12233-5500

With a copy to: Site Control Section
Division of Environmental Remediation
NYSDEC
625 Broadway
Albany, NY 12233

All notices and correspondence shall be delivered by hand, by registered mail or by Certified mail and return receipt requested. The Parties may provide for other means of receiving and communicating notices and responses to requests for approval.

7. **Recordation.** Grantor shall record this instrument, within thirty (30) days of execution of this instrument by the Commissioner or her/his authorized representative in the office of the recording officer for the county or counties where the Property is situated in the manner prescribed by Article 9 of the Real Property Law.

8. **Amendment.** Any amendment to this Environmental Easement may only be executed by the Commissioner of the New York State Department of Environmental Conservation or the Commissioner's Designee, and filed with the office of the recording officer for the county or counties where the Property is situated in the manner prescribed by Article 9 of the Real Property Law.

9. **Extinguishment.** This Environmental Easement may be extinguished only by a release by the Commissioner of the New York State Department of Environmental Conservation, or the Commissioner's Designee, and filed with the office of the recording officer for the county or counties where the Property is situated in the manner prescribed by Article 9 of the Real Property Law.

10. **Joint Obligation.** If there are two or more parties identified as Grantor herein, the obligations imposed by this instrument upon them shall be joint and several.

IN WITNESS WHEREOF, Grantor has caused this instrument to be signed in its name.

Courtlandt Corners II Housing
Development Fund Corporation

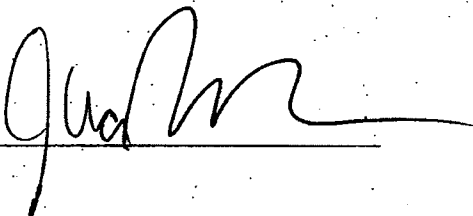
By: 

Print Name: Adam Weinstein

Title: President Date: _____

Courtlandt Corners II Associates, L.P.

By: Courtlandt Corners II Management
Corp., its general partner.

By: 

Print Name: Adam Weinstein

Title: President Date: _____

Grantor's Acknowledgment

STATE OF NEW YORK)
) ss:
COUNTY OF New York)

On the 30th day of August, in the year 20 10 before me, the undersigned, personally appeared Adam Weinstein, personally known to me or proved to me on the basis of satisfactory evidence to be the individual(s) whose name is (are) subscribed to the within instrument and acknowledged to me that he/she/they executed the same in his/her/their capacity(ies), and that by his/her/their signature(s) on the instrument, the individual(s), or the person upon behalf of which the individual(s) acted, executed the instrument.

Notary Public - State of New York

RUSSELL A KIVLER
NOTARY PUBLIC-STATE OF NEW YORK
No. 02KI6200054
Qualified in New York County
My Commission Expires January 26, 2013

SEAL

Grantor's Acknowledgment

STATE OF NEW YORK)
) ss:
COUNTY OF)

On the _____ day of _____, in the year 20 __, before me, the undersigned, personally appeared _____, personally known to me or proved to me on the basis of satisfactory evidence to be the individual(s) whose name is (are) subscribed to the within instrument and acknowledged to me that he/she/they executed the same in his/her/their capacity(ies), and that by his/her/their signature(s) on the instrument, the individual(s), or the person upon behalf of which the individual(s) acted, executed the instrument.

Notary Public - State of New York

THIS ENVIRONMENTAL EASEMENT IS HEREBY ACCEPTED BY THE PEOPLE OF THE STATE OF NEW YORK, Acting By and Through the Department of Environmental Conservation as Designee of the Commissioner,

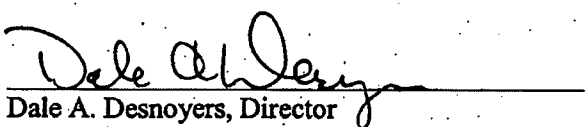
By: 
Dale A. Desnoyers, Director
Division of Remediation

Grantee's Acknowledgment

STATE OF NEW YORK)
) ss:
COUNTY OF Albany)

On the 1ST day of September in the year 2010, before me, the undersigned, personally appeared Dale Desnoyers, personally known to me or proved to me on the basis of satisfactory evidence to be the individual(s) whose name is (are) subscribed to the within instrument and acknowledged to me that he/she/ executed the same in his/her/ capacity as Designee of the Commissioner of the State of New York Department of Environmental Conservation, and that by his/her/ signature on the instrument, the individual, or the person upon behalf of which the individual acted, executed the instrument.

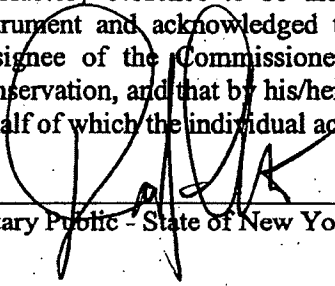
Notary Public - State of New York

David J. Chiusano
Notary Public, State of New York
No. 01CH5032146
Qualified in Schenectady County
Commission Expires August 22, 20 14

SEAL

SCHEDULE "A" PROPERTY DESCRIPTION.

875 Melrose Avenue

Bronx, NY 10451

Section: 9 Block: 2408 Lot: part of Lot 1 (formerly Lot 20)

ALL that certain plot, piece or parcel of land situate, lying and being in the Borough of the Bronx, County of Bronx, City and State of New York, and being bounded and described as follows:

BEGINNING at the corner formed by the intersection of the Northerly side of East 161st Street (100 feet wide) with the Westerly side of Melrose Avenue (80 feet wide);

Thence along the Westerly side of Melrose Avenue, North 14degrees 40 minutes 02 seconds East, 68.52 feet to a point;

Thence North 74 degrees 15 minutes 28 seconds West, 102.39 feet to a point;

Thence South 15 degrees 44 minutes 32 seconds West, 70.45 feet to a point in the Northerly sideline of East 161st Street;

Thence South 75 degrees 19 minutes 58 seconds East, 103.68 feet to the point and place of BEGINNING.

SURVEY

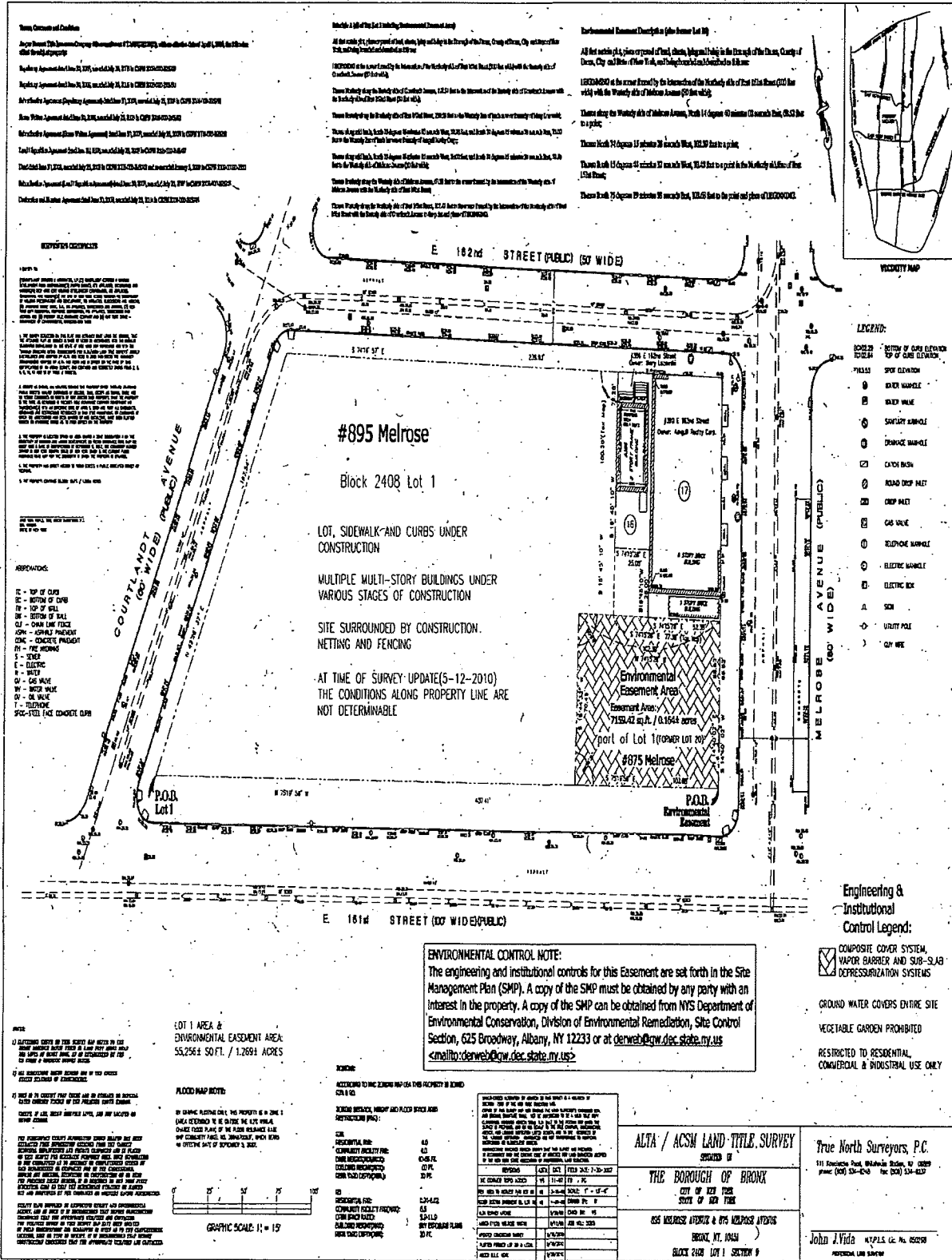

Notes Concerning Conditions

1. All lots shown on this map are subject to the provisions of the Zoning Ordinance of the City of New York, and the provisions of the Local Law of the City of New York, relating to the same.

2. The lots shown on this map are subject to the provisions of the Zoning Ordinance of the City of New York, and the provisions of the Local Law of the City of New York, relating to the same.

3. The lots shown on this map are subject to the provisions of the Zoning Ordinance of the City of New York, and the provisions of the Local Law of the City of New York, relating to the same.

Environmental Assessment Description (Site Survey Lot 1)

All lot within the project area, including the lot shown on this map, is located within the City of New York, and is subject to the provisions of the Zoning Ordinance of the City of New York, and the provisions of the Local Law of the City of New York, relating to the same.

1. The lot shown on this map is subject to the provisions of the Zoning Ordinance of the City of New York, and the provisions of the Local Law of the City of New York, relating to the same.

2. The lot shown on this map is subject to the provisions of the Zoning Ordinance of the City of New York, and the provisions of the Local Law of the City of New York, relating to the same.

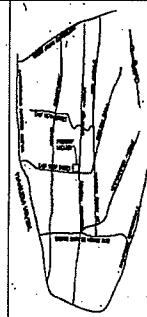

NOTES TO CONTRACTOR

1. The lot shown on this map is subject to the provisions of the Zoning Ordinance of the City of New York, and the provisions of the Local Law of the City of New York, relating to the same.

2. The lot shown on this map is subject to the provisions of the Zoning Ordinance of the City of New York, and the provisions of the Local Law of the City of New York, relating to the same.

APPENDIX

1. TOP OF CURB
2. BOTTOM OF CURB
3. TOP OF WALL
4. BOTTOM OF WALL
5. CHAIN LINE
6. ADJACENT PROPERTY
7. CONCRETE FOOTING
8. FACE OF CURB
9. STREET
10. ELECTRIC
11. WATER
12. GAS MAIN
13. SEWER MAIN
14. OIL MAIN
15. TELEPHONE
16. METAL FACE CONCRETE CURB

#895 Melrose
Block 2408 Lot 1

LOT, SIDEWALK AND CURBS UNDER CONSTRUCTION

MULTIPLE MULTI-STORY BUILDINGS UNDER VARIOUS STAGES OF CONSTRUCTION

SITE SURROUNDED BY CONSTRUCTION. NETTING AND FENCING

AT TIME OF SURVEY UPDATE (5-12-2010) THE CONDITIONS ALONG PROPERTY LINE ARE NOT DETERMINABLE

Environmental Easement Area
Easement Area: 7158.42 sq. ft. / 0.1644 acres
part of Lot 1 (former Lot 20)

- LEGEND:**
- Symbol: SECTION OF CURB ELEVATION
 - Symbol: TOP OF CURB ELEVATION
 - Symbol: SPUR ELEVATION
 - Symbol: SEWER MAIN
 - Symbol: WATER MAIN
 - Symbol: SANITARY MAIN
 - Symbol: DRAINAGE MAIN
 - Symbol: CATCH BASIN
 - Symbol: ROAD DEEP PAINT
 - Symbol: CURB PAINT
 - Symbol: GAS MAIN
 - Symbol: TELEPHONE MAIN
 - Symbol: ELECTRIC MAIN
 - Symbol: ELECTRIC BOX
 - Symbol: SIGN
 - Symbol: UTILITY POLE
 - Symbol: CURB WALK

ENVIRONMENTAL CONTROL NOTE:
The engineering and institutional controls for this Easement are set forth in the Site Management Plan (SMP). A copy of the SMP must be obtained by any party with an interest in the property. A copy of the SMP can be obtained from NYS Department of Environmental Conservation, Division of Environmental Remediation, Site Control Section, 625 Broadway, Albany, NY 12233 or at denweb@nyc.dec.state.ny.us <mailto:denweb@nyc.dec.state.ny.us>

Engineering & Institutional Control Legend:

- Symbol: COMPOSITE COVER SYSTEM, VAPOR BARRIER AND SUB-SLAB DEPRESSURIZATION SYSTEMS
- Symbol: GROUND WATER COVERS ENTIRE SITE
- Symbol: VEGETABLE GARDEN PROHIBITED
- Symbol: RESTRICTED TO RESIDENTIAL, COMMERCIAL & INDUSTRIAL USE ONLY

NOTES

1. ALL DIMENSIONS SHOWN ON THIS MAP ARE IN FEET AND INCHES UNLESS OTHERWISE SPECIFIED.

2. THE LOT SHOWN ON THIS MAP IS SUBJECT TO THE PROVISIONS OF THE ZONING ORDINANCE OF THE CITY OF NEW YORK, AND THE PROVISIONS OF THE LOCAL LAW OF THE CITY OF NEW YORK, RELATING TO THE SAME.

3. THE LOT SHOWN ON THIS MAP IS SUBJECT TO THE PROVISIONS OF THE ZONING ORDINANCE OF THE CITY OF NEW YORK, AND THE PROVISIONS OF THE LOCAL LAW OF THE CITY OF NEW YORK, RELATING TO THE SAME.

LOT 1 AREA & ENVIRONMENTAL EASEMENT AREA:
55,256.1 SQ. FT. / 1.2691 ACRES

FLOOD MAP NOTES:

1. THE LOT SHOWN ON THIS MAP IS SUBJECT TO THE PROVISIONS OF THE FLOOD DAMAGE PREVENTION ACT, AND THE PROVISIONS OF THE LOCAL LAW OF THE CITY OF NEW YORK, RELATING TO THE SAME.

2. THE LOT SHOWN ON THIS MAP IS SUBJECT TO THE PROVISIONS OF THE FLOOD DAMAGE PREVENTION ACT, AND THE PROVISIONS OF THE LOCAL LAW OF THE CITY OF NEW YORK, RELATING TO THE SAME.

NOTES

1. THE LOT SHOWN ON THIS MAP IS SUBJECT TO THE PROVISIONS OF THE ZONING ORDINANCE OF THE CITY OF NEW YORK, AND THE PROVISIONS OF THE LOCAL LAW OF THE CITY OF NEW YORK, RELATING TO THE SAME.

2. THE LOT SHOWN ON THIS MAP IS SUBJECT TO THE PROVISIONS OF THE ZONING ORDINANCE OF THE CITY OF NEW YORK, AND THE PROVISIONS OF THE LOCAL LAW OF THE CITY OF NEW YORK, RELATING TO THE SAME.

NO. 1	NO. 2	NO. 3	NO. 4	NO. 5	NO. 6	NO. 7	NO. 8	NO. 9	NO. 10
100.00	100.00	100.00	100.00	100.00	100.00	100.00	100.00	100.00	100.00

ALTA / ACSM LAND-TITLE SURVEY
THE BOROUGH OF BRONX
CITY OF NEW YORK
STATE OF NEW YORK
625 MELROSE AVENUE & 675 MELROSE AVENUE
BRONX, NY 10454
BLOCK 2408 LOT 1 SECTION 8

True North Survey, P.C.
111 Broadway, New York, NY 10038
Phone: (212) 512-4100 Fax: (212) 512-4133
John J. Vada, P.E. NYS License No. 002278
Professional Land Surveyor