



# Periodic Review Report

---

1221 Spofford Avenue  
Bronx, New York

May 30, 2023

Prepared for:

**The Peninsula JV, LLC**  
7 Jackson Walkway  
Providence, Rhode Island 02903

Prepared by:

**Roux Environmental Engineering  
and Geology, D.P.C.**  
209 Shafter Street  
Islandia, New York 11749

# Table of Contents

Executive Summary .....	1
1. Introduction .....	2
2. Site Overview .....	3
2.1 Site Description and History .....	3
2.2 Summary of Remedial Action .....	4
2.2.1 Remedial Action Objectives .....	4
2.2.2 Description of Selected Remedy .....	5
2.3 Remaining Contamination .....	7
2.3.1 Soil .....	7
2.3.2 Groundwater .....	7
2.3.3 Soil Vapor .....	7
2.4 Institutional Controls .....	8
3. Redevelopment Activity .....	9
3.1 Site-Wide Redevelopment Activity .....	9
4. SMP Requirements and Compliance Monitoring .....	10
4.1 IC Plan Compliance Report .....	10
4.1.1 Notifications .....	10
4.2 Inspections .....	11
4.3 Monitoring Plan Compliance Report .....	11
4.3.1 Groundwater Monitoring .....	12
4.3.2 Soil Vapor Intrusion Assessment .....	12
5. Overall PRR Conclusions and Recommendations .....	14

## Figures

1. Site Location Map
2. Site Layout Map and Monitoring Well Network

## Appendices

- A. NYSDEC-Approved SMP
- B. NYSDEC Communications and Approvals

## **Table of Contents (Continued)**

- C. IC/EC Certification Form
- D. Site Inspection Checklist and Photo Log

# Executive Summary

This Periodic Review Report (PRR) has been prepared by Roux Environmental Engineering and Geology, D.P.C. (Roux) on behalf of The Peninsula JV, LLC (Volunteer) and serves as a required element of the remedial program for The Peninsula, located at 1221 Spofford Avenue, Bronx, New York (hereinafter referred to as the Site). The Site is enrolled in the New York State (NYS) Brownfield Cleanup Program (BCP), which is administered by the New York State Department of Environmental Conservation (NYSDEC) and has been assigned Site Number C203097. The Site was remediated in accordance with the Brownfield Cleanup Agreement (BCA) Index #C203097-10-17, which was executed on December 13, 2017, and a Certificate of Completion (COC) was issued by NYSDEC for the Site on December 29, 2020. The remedial action (RA) for this Site achieved a Track 2 Restricted Residential remedy and therefore, no engineering controls are required under the Site Management Plan (SMP), dated December 11, 2020, which was approved by NYSDEC on December 14, 2020.

The following sections provide a brief summary of the institutional controls (ICs) implemented for the Site, as well as the inspections, monitoring, and reporting activities completed in accordance with the SMP. The required Site-wide inspection was completed on May 1, 2023 to represent this SMP monitoring phase from April 2022 to April 2023. The components, data, and rationale included in this PRR demonstrate that the ICs are performing as designed, are effective, and are compliant with specifications described in the SMP. No changes to the monitoring plan are recommended by Roux at this time.

# 1. Introduction

This Periodic Review Report (PRR) was prepared by Roux Environmental Engineering and Geology, D.P.C. (Roux) on behalf of The Peninsula JV, LLC (Volunteer) and serves as a required element of the remedial program for The Peninsula, located at 1221 Spofford Avenue, Bronx, New York (hereinafter referred to as the Site). A Site Location Map is attached as Figure 1. This PRR verifies that existing Institutional Controls (ICs) and monitoring are still effective. This PRR also documents post-remediation activities performed at the Site from April 2022 through April 2023.

The Peninsula JV, LLC entered into a Brownfield Cleanup Agreement (BCA) with the New York State Department of Environmental Conservation (NYSDEC) on November 7, 2017 (Site Number C203097), to remediate the approximately 3.734-acre property located at the above address identified as Block 2738 and Lots 2, 35, 36, and 37 on the Bronx County Tax Map. The property was remediated to allow for restricted residential, commercial, or industrial use and Site redevelopment is ongoing for the construction of a mixed-use campus and four individual buildings. The Site Management Plan (SMP) dated December 11, 2020, (Appendix A) was approved by NYSDEC on December 14, 2020, and the Certificate of Completion (COC) for the Site was issued by NYSDEC on December 29, 2020.

Site management activities, reporting, and an IC certification are scheduled on a certification period basis in the NYSDEC-approved SMP. This certification is based on the submission of a PRR (included herein), submitted to the NYSDEC every year beginning fifteen months after the COC was issued. These PRRs will identify and assess all of the ICs required by the remedy for the Site, any environmental monitoring data and/or information generated during the reporting period, and a complete Site evaluation that discusses the overall performance and effectiveness of the remedy.

## 2. Site Overview

### 2.1 Site Description and History

The Site is located in the Hunts Point neighborhood in the county of the Bronx, New York and is identified as Block 2738 and Lots 2, 35, 36, and 37 on the Bronx County Tax Map. The Site is an approximately 3.374-acre area and is bounded by the Corpus Christi Monastery to the north, Spofford Avenue to the south, a demapped portion of Barretto Street to the east, and Tiffany Street to the west (see Figure 1 – Site Location Map). The Site currently consists of two buildings, building 1A (Lot 36) and building 1B (Lot 37), that are currently under construction. The remaining portion of the Site, Lots 2 and 35, have undergone excavation as part of the Site’s remediation and are currently vacant in preparation for future construction of buildings 2A and 2B. Foundation and superstructure construction of Buildings 1A and 1B has been completed. Building 1A received the temporary certificate of occupancy (TCO) on January 20, 2022 and the final certificate of occupancy (FCO) on November 9, 2022. Building 1B received a Residential TCO on June 9, 2022 and Retail Community Facility TCO on January 20, 2023. The construction of buildings 2A and 2B is scheduled to begin in the third quarter of 2023.

Historical information and previous investigations indicated that historical Site usage included a stone cutting yard, automobile garages, an office, a residential dwelling, and the Spofford Juvenile Detention Facility, later renamed as Bridges Juvenile Center, which was in operation from 1956 to 2011.

Previous environmental site assessments were completed to investigate a release of #2 fuel oil (NYSDEC Spill #0812579) that occurred at the Site on February 18, 2009. As a result of this release, approximately 2,000 gallons of #2 fuel oil was released to the subsurface from two 12,000-gallon underground storage tanks (USTs) located in the southeast courtyard of the Site. Analytical data and findings from an initial investigation revealed evidence of petroleum contamination in subsurface soils immediately surrounding the area of the two USTs. In addition, separate phase petroleum product was observed atop groundwater perched above bedrock at soil borings installed in the former boiler room adjacent to the north of the USTs and the exterior lot adjacent to the USTs. Subsequent environmental investigations were completed at the Site including a Remedial Investigation (RI) by Roux in 2018, which determined the following conclusions regarding the contamination of soil, groundwater, and soil vapor present at the Site:

- Soil at the Site was impacted with metals and some polycyclic aromatic hydrocarbons (PAHs) that exceeded NYSDEC restricted residential soil cleanup objectives (RRSCOs). Historical operations at the Site suggested Site soils were impacted through inadvertent releases to the subsurface (i.e., recorded oil spill and historic fill) resulting in localized hot-spot contamination in soil.
- Based on Site-wide detections and exceedances of NYSDEC Ambient Water Quality Standard Guidance Values (AWQSGVs) and the presence of separate phase product (petroleum), groundwater at the Site was impacted with metals and VOCs. Groundwater contamination resulted from inadvertent releases to Site soils (i.e., recorded oil spill), and the migration of contaminants through the unconsolidated soil to Site groundwater.
- Site-wide soil vapor was impacted with VOCs (specifically petroleum related compounds), through the inadvertent releases to Site soils. Chlorinated volatile organic compounds (CVOCs), primarily Trichloroethylene (TCE) and Tetrachloroethene (PCE), were also detected in soil vapor; however, the concentrations were relatively low. Migration of soil vapor from the former source areas

beneath the former boiler room basement and the UST pad to other portions of the Site was initially considered an environmental concern due to the presence of separate phase product that had the potential to affect soil vapor across the Site.

## **2.2 Summary of Remedial Action**

The Site was remediated in accordance with the NYSDEC-approved Interim Remedial Measure (IRM) Work Plan dated August 6, 2018, the NYSDEC-approved Remedial Action Work Plan (RAWP) dated December 2018, and the Amendment to the RAWP dated November 6, 2019 (2019 Amendment), as discussed in Section 2.2.2. Prior to implementation of the NYSDEC-approved RAWP, demolition of the former onsite buildings, the temporary closure of two onsite USTs, and the completion of two geotechnical test pits were completed as IRMs in accordance with the NYSDEC-approved IRM Work Plan. RAWP implementation began in August 2019 and was completed in August 2020. Under direction from the NYSDEC, the remedial action (RA) work was overseen by Roux to ensure compliance with the RAWP.

### **2.2.1 Remedial Action Objectives**

The Remedial Action Objectives (RAOs) for the Site as listed in the Decision Document (DD) dated December 17, 2018, are as follows:

#### **Groundwater**

RAOs for Public Health Protection

- Prevent ingestion of groundwater with contaminant levels exceeding drinking water standards.
- Prevent contact with, or inhalation of, volatiles from contaminated groundwater.

RAOs for Environmental Protection

- Restore groundwater aquifer, to the extent practicable, to pre-disposal/pre-release conditions.
- Remove the source of ground or surface water contamination.

#### **Soil**

RAOs for Public Health Protection

- Prevent ingestion/direct contact with contaminated soil.
- Prevent inhalation of, or exposure from contaminants volatilizing from contaminants in soil.

RAOs for Environmental Protection

- Prevent migration of contaminants that would result in groundwater or surface water contamination.

#### **Soil Vapor**

RAOs for Public Health Protection

- Mitigate impacts to public health resulting from existing, or the potential for, soil vapor intrusion (SVI) into future new buildings at a site.

## 2.2.2 Description of Selected Remedy

The Site was remediated in accordance with the remedy selected by the NYSDEC in the NYSDEC-approved Interim Remedial Measures Workplan (IRMWP), NYSDEC-approved RAWP, the 2019 RAWP Amendment, and the DD. The selected remedy, as outlined in the 2018 RAWP, was a Track 1 with a contingency plan to achieve a Track 4 restricted residential use remedy. A Track 1 remedy was initially selected because the excavation to install the proposed buildings' foundations reached the shallow bedrock elevations that were observed during the Site's geotechnical investigation. However, after the submittal of the RAWP, the required excavation depths for redevelopment were modified and the observed competent bedrock elevations were deeper than expected. With these changes, the final excavation depths for the majority of the buildings' footprints did not reach competent bedrock. The 2019 RAWP Amendment, in which a multi-track approach consisting of a remedy meeting Track 1 unrestricted use soil SCOs, Track 2 restricted residential SCOs, and Track 4 restricted residential SCOs in certain portions of the Site, was approved by NYSDEC on November 13, 2019. The 2019 RAWP Amendment specified that the Site would achieve a Track 1 remedy where excavation extends to competent bedrock with the remainder of the Site consisting of a Track 2 remedy with a Track 4 contingency. The selection of a Track 2 versus Track 4 remedy was based on the analytical results of confirmation endpoint sample results at the final excavation depths. At the completion of the RA, the areas excavated down to bedrock were isolated and discontinuous and therefore it was not feasible to classify these specific areas as a Track 1 remedy. Following final excavation and collection of the required Site-wide endpoint samples, NYSDEC determined that excavation achieved the Track 2 remedial action objectives throughout the entire Site, as stated in the NYSDEC-issued letter dated September 15, 2020.

The following are the components of the IRMs completed at the Site in accordance with the IRM Work Plan, dated August 6, 2018, and approved by the NYSDEC on August 9, 2018, that were completed prior to the implementation of the RAWP:

1. Demolition of the three six-story buildings onsite that were vacant and their associated sub-grade features;
2. Cleaning, inerting, and temporary closure of two 12,000-gallon, #2 fuel oil USTs; and
3. Completion of two geotechnical test pits.

The following are the components of the selected and completed remedy as outlined in the RAWP and the 2019 Amendment:

1. Site monitoring of potential airborne volatile organic compounds (VOCs) and particulates in accordance with the NYSDEC-approved Community Air Monitoring Plan (CAMP) during all ground-intrusive and soil handling activities.
2. Implementation of dust and odor suppression techniques during all ground-intrusive and soil handling activities.
3. Demolition of the existing onsite buildings and proper offsite disposal of materials which cannot be beneficially reused onsite in order to implement the remedy.
4. Excavation and offsite disposal of all onsite sources of contamination, which include soil/fill exceeding the lower of RRSCOs and Protection of Groundwater Soil Cleanup Objectives (PGWSCOs) (approximately 40,240 cubic yards [CY]), fill material (historically observed at depths



ranging from 2 to 14 ft bls), and petroleum-contaminated soil associated with UST source areas in the upper 15 feet below ground surface.

5. All offsite disposal of material from the Site is to be completed in accordance with all Federal, State, and local rules and regulations for handling, transport, and disposal.
6. Collection and analysis of post-excavation Site-wide endpoint samples to evaluate the performance of the remedy with respect to attainment of RRSCOs and PGWSCOs in the upper 15 feet below land surface (ft bls).
7. Excavation and removal of underground storage tanks (USTs) and associated piping associated with NYSDEC spill no. 0812579 and PBS no. 2-604085.
8. Installation of dewatering and water treatment system to facilitate remedial excavation.
9. Installation of support of excavation (SOE) as needed for remedial excavation.
10. Implementation of soil erosion and sediment controls.
11. Screening for indications of contamination (by visual means, odor, and monitoring with photoionization detector [PID]) in all excavation soil during all ground-intrusive activities.
12. The onsite reuse of soil, in compliance with the RRSCOs, as needed for backfill. A total of approximately 13,400 CY of soil were reused as backfill behind building foundation walls, to raise the final grade, and/or to construct an access ramp at the Site.
13. The import of approximately 4,786 CY of clean fill meeting the requirements of 6 NYCRR Part 375 6.7(d) were used to backfill behind the building foundation walls, create construction access roadways and ramps, create stabilized construction entrances, and for use as subbase during construction of the buildings' foundations.
14. Following completion of the remedy and prior to issuance of the Certificate of Completion (COC), in order to ensure that groundwater meets the Ambient Water Quality Standards and Guidance Values (AWQSGVs) or there has been an asymptotic bulk reduction in groundwater contamination, groundwater monitoring from bedrock monitoring wells BRMW-1 and BRMW-2 was performed in accordance with Baseline Sampling Procedures included in Section 6.2 of the NYSDEC-approved RAWP.
15. Execution and recording of an Environmental Easement to restrict land use and prevent future exposure to any contamination remaining at the site.
16. Development and implementation of a Site Management Plan (SMP) for long-term management of remaining contamination as required by the Environmental Easement, which includes plans for: (1) Institutional Controls (ICs), (2) monitoring, (3) operation and maintenance and (4) reporting.
17. Periodic certification of the ICs listed above.

Remedial activities for soil and groundwater were completed at the Site in August 2020. Additional details of the RAWP implementation and completion are documented fully in the FER.

## 2.3 Remaining Contamination

The RA for this Site achieved the Track 2 RRSCOs through the excavation and proper offsite disposal of all fill material, excavation of soil in areas of the Site identified during the RI as exceeding RRSCOs and/or PGWSCOs, removal of USTs, and excavation of petroleum-contaminated soil and weathered bedrock associated with the former UST source area and closure of spill # 0812579.

### 2.3.1 Soil

During the RA, excavation was completed to depths ranging from 2 to 25 ft bls, which extended to competent bedrock in some areas across the Site. Excavation was completed to remove petroleum-contaminated soil and weathered bedrock associated with the former UST source area and contaminated fill material and contaminated soil in areas of the Site exceeding the lesser of RRSCOs and/or PGWSCOs as previously identified during the RI. The RA also included the removal of USTs and closure of NYSDEC Spill #0812579. In accordance with the RAWP, 119 post-excavation endpoint samples and seven duplicate samples were collected at a frequency of 1 sample per 2,000 square feet (SF) to determine that Track 2 SCOs were achieved. In areas where the excavation extended to competent bedrock, no endpoint samples were collected, and bedrock was swept clean of all soils and photo documented.

Endpoint sampling results yielded nine sample locations that slightly exceeded RRSCOs or PGWSCOs for SVOCs and metals. The several minor exceedances of Site RRSCOs remaining in soil at the Site were addressed via the Post-Remediation Confirmation Endpoint Sample Statistical Evaluation, and based on this evaluation NYSDEC determined that excavation has achieved the Track 2 remedial action objectives as stated in the letter issued on September 15, 2020.

### 2.3.2 Groundwater

Groundwater contamination has been remediated through excavation and offsite disposal of soil from the former UST source area, excavation of fill material, and excavation of soil exceeding RRSCOs and/or PGWSCOs. Excavation within the former UST source area and directly downgradient was extended to competent or weathered bedrock. The underlying bedrock did not exhibit signs of impact (i.e., odor, staining, or elevated photoionization detector [PID] readings, etc.). As discussed in the NYSDEC-approved RAWP, the installation of two bedrock monitoring wells and collection of quarterly baseline groundwater samples were required for one year following the completion of the RA. A Site and monitoring well network layout map is attached as Figure 2. Quarterly baseline groundwater sampling was completed from July 2020 to June 2021 and the analytical results were reported in the prior PRR. Groundwater analytical results from all baseline groundwater samples did not yield exceedances of AWQSGVs. On June 22, 2021, NYSDEC issued an approval to cease groundwater monitoring at the Site, included in Appendix B. Baseline groundwater monitoring is summarized in Section 4.3.1.

### 2.3.3 Soil Vapor

The onsite soil vapor contamination was addressed during the RA through the completion of the former UST source area soil removal, which was extended down to competent or weathered bedrock. In areas where excavation extended to soil or weathered bedrock, bottom soil endpoint samples were collected that yielded analytical results below UUSCOs. A soil vapor intrusion (SVI) assessment was completed as part of the NYSDEC-approved Final Engineering Report (FER), dated December 16, 2020, which

demonstrated that the RA has addressed potential exposures related to SVI for future buildings 1A, 1B, 2A, and 2B.

A soil vapor intrusion (SVI) evaluation must be performed upon a change in use of the property that will result in occupancy of a previously unoccupied building or initial occupancy of a new building (excluding buildings 1A, 1B, 2A, and 2B which were previously evaluated as part of the NYSDEC-approved FER). The breadth of this evaluation will be determined based upon discussion with the NYSDEC Project Manager and NYSDOH and will be conducted in accordance with the NYSDEC-Approved SMP, if required to be completed.

## **2.4 Institutional Controls**

A Site-specific Environmental Easement has been recorded with the City Register of the City of New York that provides an enforceable means to manage the remaining contamination at the Site until the Environmental Easement is extinguished in accordance with ECL Article 71, Title 36. The ICs presented in the SMP consist of the following:

- The property may be used for: restricted residential, commercial, and industrial use;
- The use of groundwater underlying the property is prohibited without necessary water quality treatment as determined by the NYSDOH or the New York City Department of Health and Mental Hygiene to render it safe for use as drinking water or for industrial purposes, and the user must first notify and obtain written approval to do so from the Department;
- Environmental and/or public health monitoring must be performed as defined in the SMP;
- Data and information pertinent to Site management must be reported at the frequency and in a manner as defined in the SMP;
- All future activities that will disturb remaining contaminated material must be conducted in accordance with the SMP;
- Access to the Site must be provided to agents, employees, or other representatives of the State of New York with reasonable prior notice to the property owner to assure compliance with the restrictions identified by the Environmental Easement;
- The potential for vapor intrusion must be evaluated for any buildings developed in the area within the IC boundaries (excluding buildings 1A, 1B, 2A, and 2B which were previously evaluated as part of the NYSDEC-approved FER) noted on the figure included in the Environmental Easement, and appropriate actions to address exposures must be implemented; and
- Vegetable gardens and farming on the Site are prohibited.

## **3. Redevelopment Activity**

### **3.1 Site-Wide Redevelopment Activity**

Following the completion of the RA, redevelopment activities continued at buildings 1A and 1B at the Site. Redevelopment activity has not commenced for buildings 2A and 2B, which are scheduled to begin in the third quarter of 2023. Redevelopment activities completed during this reporting period includes interior general construction at buildings 1A and 1B. Building 1A received the temporary certificate of occupancy (TCO) on January 20, 2022 and the final certificate of occupancy (FCO) on November 9, 2022. Building 1B received a Residential TCO on June 9, 2022 and Retail Community Facility TCO on January 20, 2023.

### **3.2 Material Import Summary**

There was no material imported or exported from the Site during this reporting period.

### **3.3 Dewatering Activities**

Following the completion of the RA, an excavation completed in the western portion of the Site (Lot 35) continued to fill with stormwater and groundwater accumulation. In accordance with the New York City Department of Environmental Protection (NYCDEP) discharge permit #898250, issued on February 10, 2020, and #C001488619, issued on May 5, 2022. In accordance with permit requirements, dewatered fluids removed from this area were treated via 300-gallon settling tank and discharged to the combined municipal sewer system at the Site.

## 4. SMP Requirements and Compliance Monitoring

ICs are required to protect human health and the environment. This section details the elements of the SMP including the inspection, monitoring, and reporting requirements, ICs, whether the IC requirements were met, and regulatory notification and certification requirements. The various subsections below also include an evaluation of the remedy performance, effectiveness, and protectiveness.

### 4.1 IC Plan Compliance Report

Since remaining contamination exists beneath the Site, ICs are required to protect human health and the environment, which are described previously in Section 2.4.

For each IC identified for the Site, I certify that all of the following statements are true:

- The institutional control employed at this Site is unchanged from the date the control was put in place, or last approved by the Department;
- Nothing has occurred that would impair the ability of the control to protect the public health and environment;
- Nothing has occurred that would constitute a violation or failure to comply with any Site management plan for this control;
- Access to the Site will continue to be provided to the Department to evaluate the remedy, including access to evaluate the continued maintenance of this control;
- Use of the Site is compliant with the environmental easement; and
- The information presented in this report is accurate and complete.

I certify that all information and statements in this certification form are true. I understand that a false statement made herein is punishable as a Class "A" misdemeanor, pursuant to Section 210.45 of the Penal Law. I, Ed Broderick, of The Peninsula JV LLC., am certifying as Owner's Designated Site Representative and I have been authorized and designated by all Site owners to sign this certification for the Site.

An IC Certification Form for the controls that are currently in place is included as Appendix C.

#### 4.1.1 Notifications

Notifications will be submitted by the property owner to the NYSDEC as needed for the following reasons:

- 60-day advance notice of any proposed changes in Site use that are required under the terms of the BCA, 6NYCRR Part 375, and/or Environmental Conservation Law.
- 15-day advance notice of any proposed ground-intrusive activities pursuant to the EWP.
- 7-day advance notice of any field activity associated with the remedial program.

Any change in the ownership of the Site or the responsibility for implementing this SMP will include the following notifications:

- At least 60 days prior to the change, the NYSDEC will be notified in writing of the proposed change. This will include a certification that the prospective purchaser has been provided with a copy of the BCA, and all approved work plans and reports, including the SMP.
- Within 15 days after the transfer of all or part of the Site, the new owner's name, contact representative, and contact information will be confirmed in writing.

NYSDEC was notified prior to intrusive work associated with stormwater sump installation.

## 4.2 Inspections

Roux conducted a Site-wide inspection on May 1, 2023. The completed Site Inspection Checklist and photographs taken during the Site-wide inspection are provided in the Photo Log included in Appendix D.

All inspections were conducted at the frequency specified in the schedules provided in following Monitoring Plan Reporting section of this PRR. At a minimum, one comprehensive Site-wide inspection is to be conducted annually (starting no more than 15 months after the issuance of the COC) per the SMP. The inspections determine and document the following:

- Compliance with all ICs, including Site usage;
- General Site conditions at the time of the inspection;
- The Site management activities being conducted including, where appropriate, confirmation sampling and a health and safety inspection;
- If these controls continue to be protective of human health and the environment;
- Compliance with the requirements of the SMP and the Environmental Easement; and
- If Site records are complete and up to date.

Site-wide inspections will also be performed after all severe weather conditions that may affect the remaining contamination at the Site. Inspections will also be performed in the event of an emergency. An inspection of the Site will be conducted within 5 days of the event to verify the effectiveness of the ICs implemented at the Site by a qualified environmental professional, as determined by the NYSDEC. Written confirmation must be provided to the NYSDEC within 7 days of the event that includes a summary of actions taken, or to be taken, and the potential impact to the environment and the public.

## 4.3 Monitoring Plan Compliance Report

The Monitoring Plan describes the measures for evaluating the performance and effectiveness of the remedy to reduce or mitigate contamination at the Site, the Site cover system, and all affected Site media identified below. Components of the Monitoring Plan are:

- Sampling and analysis of all appropriate media (e.g., groundwater).
- Assessing compliance with applicable NYSDEC standards, criteria, and guidance, particularly ambient groundwater standards and Part 375 SCOs for soil.
- Assessing achievement of the remedial performance criteria.

- Evaluating Site information periodically to confirm that the remedy continues to be effective in protecting public health and the environment.
- Preparing the necessary reports for the various monitoring activities.

Monitoring of the performance of the remedy and overall reduction in contamination onsite will be conducted for the periods specified for each matrix listed in table below. The frequency thereafter will be determined in consultation with NYSDEC and based on reports submitted showing contaminant trends.

Monitoring Program	Frequency	Matrix	Analysis	Status
Site-Wide Inspection	Annually.	Soil	Confirm compliance with all ICs.	Ongoing
Groundwater	Quarterly for TCL VOCs for one year following successful completion of the RA.	Groundwater	Collect samples and analyze for Target Compound List (TCL) VOCs (USEPA Method 8260).	Complete
Soil Vapor Intrusion Evaluation - Completion of a soil vapor intrusion evaluation as part of Site redevelopment. An SVI has already been completed as part of the NYSDEC-approved FER.	An SVI evaluation must be performed upon a change in the use of the property that will result in occupancy of a previously unoccupied building or initial occupancy of a new building. This SVI will determine the potential for vapor intrusion into Site buildings located above the water table. If additional soil vapor sampling is required, locations will be selected in coordination with NYSDEC/NYSDOH	Soil Vapor	To be completed prior to building occupancy. Any monitoring or mitigation actions recommended to address exposures will be memorialized in an addendum to the SMP.	Complete for buildings 1A, 1B, 2A, and 2B

\* The frequency of events will be conducted as specified above until otherwise approved by NYSDEC and NYSDOH. Although not anticipated, monitoring wells that have NAPL present will not be sampled.

A record of the findings of each monitoring/inspection event and resulting maintenance activity performed, where applicable, will be kept in a dedicated logbook and documented on the Site Inspection Checklist (Appendix D), described in further detail below. If at any time during the reporting period the Volunteer identifies non-compliance with one or more of the ICs, the remedial party must notify NYSDEC and implement corrective measures, in accordance with a Corrective Measures Work Plan (CMWP) submitted to and approved by NYSDEC and provide a periodic certification of the ICs.

### 4.3.1 Groundwater Monitoring

Groundwater monitoring, as required by the NYSDEC-approved SMP and as approved by NYSDEC via e-mail on June 25, 2020, was completed and summarized in the prior PRR, dated June 3, 2022.

Groundwater samples were collected on July 15, 2020, October 8, 2020, March 12, 2021, and June 1, 2021. Groundwater analytical results from all baseline groundwater samples did not yield exceedances of AWQSGVs. On June 22, 2021, NYSDEC issued an approval to cease groundwater monitoring at the Site, included in Appendix B.

### 4.3.2 Soil Vapor Intrusion Assessment

A soil vapor intrusion evaluation was already completed as part of the NYSDEC-approved FER and therefore, there is no further need for an SVI evaluation at the time of this PRR. A soil vapor intrusion

evaluation will be complete as part of any future proposed redevelopment, in accordance with the NYSDEC-approved SMP.



## 5. Overall PRR Conclusions and Recommendations

The following section presents conclusions from inspections and monitoring activities as well as recommendations.

1. The ICs are in place and are compliant with specifications described in the SMP and/or described in this PRR. No changes to the monitoring plan are recommended at this time.

**FIGURES**

1. Site Location Map
2. Site Layout Map and Monitoring Well Network

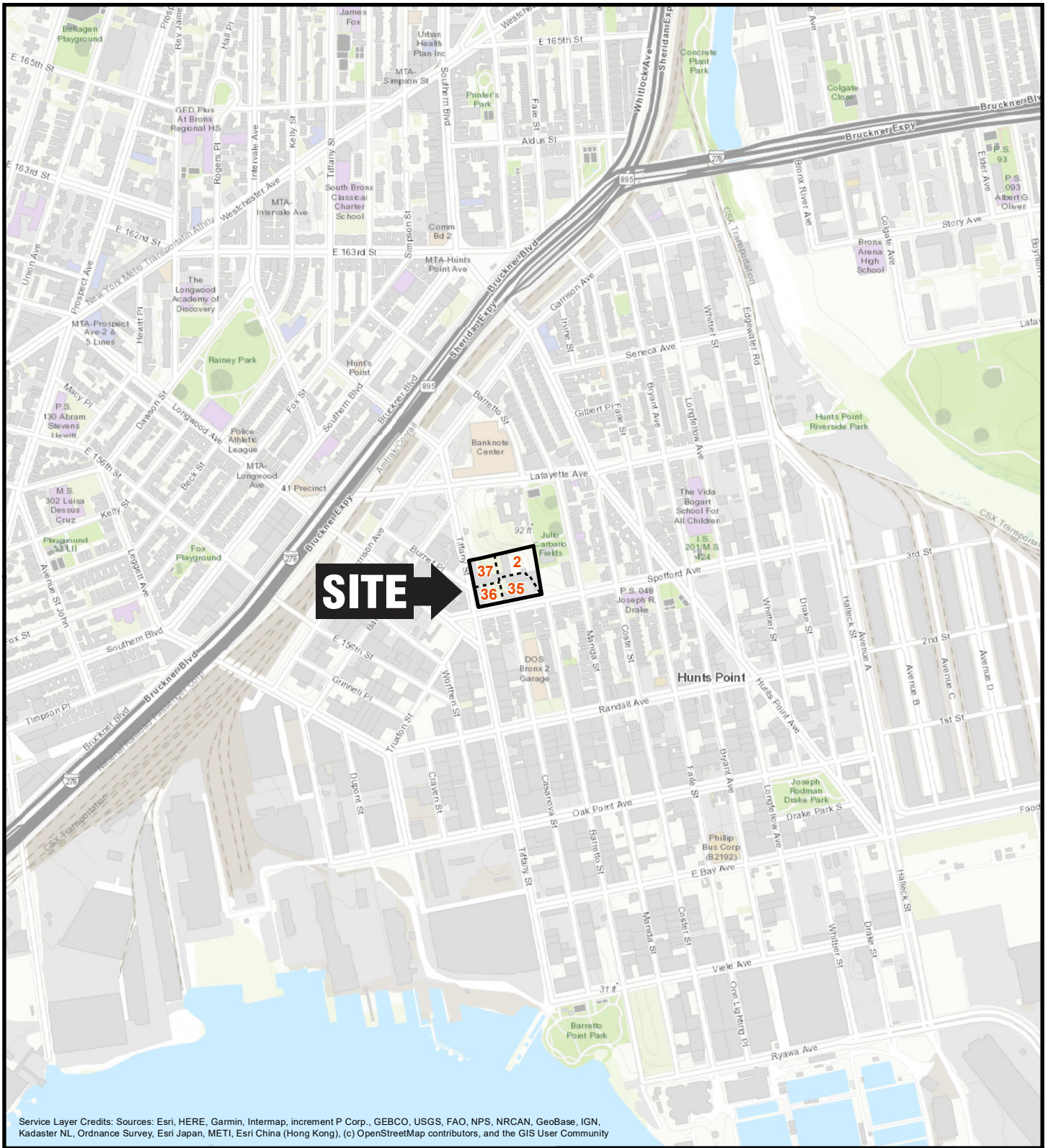

Service Layer Credits: Sources: Esri, HERE, Garmin, Intermap, increment P Corp., GEBCO, USGS, FAO, NPS, NRCAN, GeoBase, IGN, Kadaster NL, Ordnance Survey, Esri Japan, METI, Esri China (Hong Kong), (c) OpenStreetMap contributors, and the GIS User Community

**QUADRANGLE LOCATION**

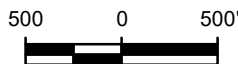

Title:

**SITE LOCATION MAP**

PERIODIC REVIEW REPORT  
BLOCK 2738, LOTS 2, 35, 36, AND 37  
1221 SPOFFORD AVENUE, BRONX, NY

Prepared for:

THE PENINSULA JV, LLC



Compiled by: M.O.	Date: 05/05/23
Prepared by: M.S.R.	Scale: AS SHOWN
Project Mgr: L.D.	Project: 2611.0002Y000
File: 2611.0002Y205.1.mxd	

FIGURE

**1**

VA-CAD-PROJECTS\2611\0002\Y205\2611.0002\Y205.02.DWG

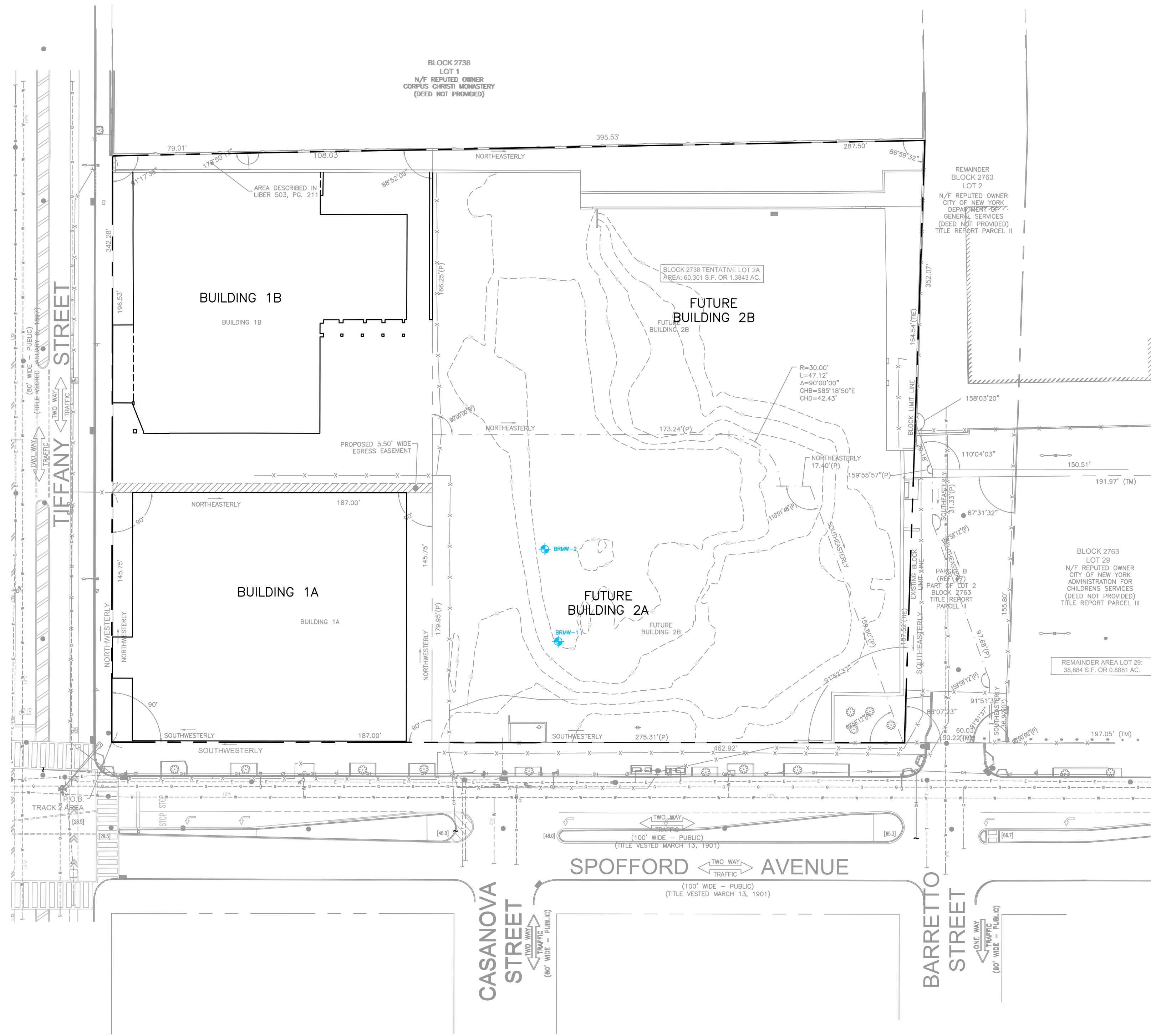

**LEGEND**

— SITE BOUNDARY

BRMW-1 DESIGNATION AND APPROXIMATE LOCATION OF BEDROCK MONITORING WELL

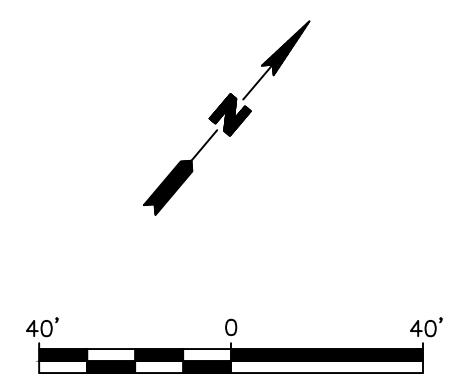

Title:			
<b>SITE LAYOUT AND MONITORING WELL NETWORK</b>			
PERIODIC REVIEW REPORT 1221 SPOFFORD AVENUE, BRONX, NEW YORK			
Prepared For:			
THE PENINSULA JV, LLC			
Compiled by: P.R.	Date: 28APR23	<b>FIGURE 2</b>	
Prepared by: B.H.C.	Scale: AS SHOWN		
Project Mgr: L.D.	Project: 2611.0002Y000		
File: 2611.0002Y205.02.DWG			



**APPENDICES**

- A. NYSDEC Communications and Approvals
- B. NYSDEC-Approved SMP
- C. IC/EC Certification Form
- D. Site Inspection Checklist and Photo Log

NYSDEC Communications and Approvals

# NEW YORK STATE DEPARTMENT OF ENVIRONMENTAL CONSERVATION

Division of Environmental Remediation, Region 2  
47-40 21st Street, Long Island City, NY 11101  
P: (718) 482-4995  
www.dec.ny.gov

June 22, 2021

Ed Broderick  
The Peninsula JV, LLC  
7 Jackson Walkway  
Providence, RI 02903

**RE: The Peninsula, Bronx, Bronx County  
Brownfield Cleanup Program # C203097  
Groundwater Monitoring Response**

Dear Mr. Broderick:

The New York State Department of Environmental Conservation (the Department) has reviewed the groundwater cessation request dated June 14, 2021 which included the post-excavation groundwater monitoring results dated July 2020, October 2020, March 2021 and June 2021. The document was prepared by Roux Environmental Engineering and Geology, D.P.C. on behalf of The Peninsula JV, LLC (the Volunteer). Based on the Department's review of the request, as well as the data obtained during these groundwater monitoring events, the Department approves the request to discontinue groundwater monitoring.

In accordance with the approved Site Management Plan (SMP) dated December 2020, existing on-site groundwater monitoring wells must be properly decommissioned in accordance with NYSDEC CP-43. The decommissioning should be documented in the next Periodic Review Report.

Should you have any questions regarding this letter or any other aspect of the project, please contact me at (718) 482-7541 or wendi.zheng@dec.ny.gov.

Sincerely,

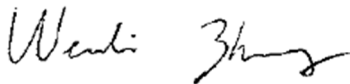

Wendi Zheng  
Project Manager

ec: J. O'Connell, A. Levine – NYSDEC  
S. McLaughlin, M. Doroski – NYSDOH



Department of  
Environmental  
Conservation

I. Speliotis – MHANY Peninsula Local Development Corp., Spofford 1B Housing  
Development Fund Corp.  
A. Koffman – Peninsula Building 1B LLC  
F. Cherena, L. Dolginko – Roux  
L. Schnapf – Schnapf LLC



NYSDEC-Approved SMP

**THE PENINSULA  
BRONX COUNTY  
BRONX, NEW YORK**

---

# **SITE MANAGEMENT PLAN**

**NYSDEC Site Number: C203097**

**Prepared for:**

The Peninsula JV, LLC  
7 Jackson Way, Providence, Rhode Island 02903

**Prepared by:**

Roux Environmental Engineering and Geology, D.P.C.  
209 Shafter Street, Islandia, New York 11749 631-232-2600

**Revisions to Final Approved Site Management Plan:**

<b>Revision No.</b>	<b>Date Submitted</b>	<b>Summary of Revision</b>	<b>NYSDEC Approval Date</b>

---

**DECEMBER 2020**

CERTIFICATION STATEMENT

I, Brian P. Morrissey, certify that I am currently a NYS registered professional engineer and that this Site Management Plan was prepared in accordance with all applicable statutes and regulations and in substantial conformance with the DER Technical Guidance for Site Investigation and Remediation (DER-10).



\_\_\_\_\_ P.E.

\_\_\_\_\_ December 11, 2020 \_\_\_\_\_ DATE

TABLE OF CONTENTS

**THE PENINSULA  
BRONX COUNTY  
BRONX, NEW YORK  
SITE MANAGEMENT PLAN**

**Table of Contents**

ES	EXECUTIVE SUMMARY .....	8
1.0	INTRODUCTION .....	10
1.1	General .....	10
1.2	Revisions .....	11
1.3	Notifications .....	11
2.0	SUMMARY OF PREVIOUS REMEDIAL INVESTIGATIONS AND REMEDIAL ACTIONS.....	13
2.1	Site Location and Description .....	13
2.2	Physical Setting .....	14
2.2.1	Land Use .....	14
2.2.2	Geology.....	14
2.2.3	Hydrogeology .....	15
2.3	Investigation and Remedial History .....	15
2.3.1	Remedial Action Plan (LBA 2010) (also includes 2009 Remedial Investigation by reference) .....	17
2.3.2	Groundwater Monitoring and Remediation Report for the Fourth Quarter 2016 (URS, 2017).....	19
2.3.3	Phase I ESA prepared by Arcadis, Inc., dated June 3, 2016.....	20
2.3.4	Roux Phase I ESA (2017).....	21
2.3.5	Roux Phase II ESA (2017).....	22
2.3.6	Remedial Investigation Report Results.....	24
2.4	Remedial Action Objectives.....	29
2.4.1	Groundwater .....	29
2.4.2	Soil .....	29

2.4.3 Soil Vapor ..... 29

2.5 Remaining Contamination..... 30

2.5.1 Soil ..... 30

2.5.1.1 Excavation for Future Redevelopment..... 31

2.5.2 Groundwater ..... 32

2.5.3 Soil Vapor ..... 33

3.0 INSTITUTIONAL CONTROL PLAN..... 34

3.1 General ..... 34

3.2 Institutional Controls..... 34

3.3 Site – wide Inspection ..... 35

4.0 MONITORING AND SAMPLING PLAN ..... 37

4.1 General ..... 37

4.2 Groundwater Monitoring..... 37

4.2.1 Groundwater Sampling ..... 38

5.0 PERIODIC ASSESSMENTS/EVALUATIONS ..... 40

5.1 Climate Change Vulnerability Assessment..... 40

5.1.1 Flood Plain ..... 40

5.1.2 Erosion ..... 40

5.1.3 Electricity ..... 40

5.1.4 Site Drainage and Storm Water Management ..... 41

5.1.5 High Wind..... 41

5.1.6 Spill/Contaminant Release..... 41

5.2 Soil Vapor Intrusion Evaluation..... 41

6.0 REPORTING REQUIREMENTS ..... 42

6.1 Site Management Reports ..... 42

6.2 Periodic Review Report ..... 43

6.2.1 Certification of Institutional Controls..... 44

6.3 Corrective Measures Work Plan ..... 45

7.0 REFERENCES ..... 46

**List of Tables**

- 
- 1. Notifications (*Embedded in Text in Section 1.3*)
  - 2. Groundwater Elevation Measurements

3. Summary of Remaining Semivolatile Organic Compound Exceedances in Soil
4. Summary of Remaining Metal Exceedances in Soil
5. Summary of Remaining Pesticide and Herbicide Exceedances in Soil
6. Schedule of Inspection Reports (*Embedded in Text in Section 6.1*)

### **List of Figures**

---

Figure 1 - Site Location Map

Figure 2 – Site Layout Map

Figure 3 – Generalized Hydrogeologic Cross Sections A-A` and B-B`

Figure 4 - Groundwater Contour Map

Figure 5 – Exceedances of Applicable Soil Cleanup Objectives

Figure 6 – Monitoring Well Network

### **List of Appendices**

---

Appendix A – Environmental Easement

Appendix B - List of Site Contacts

Appendix C – Responsibilities of Owner and Remedial Party

Appendix D – Site-Specific Boring Logs

Appendix E – Monitoring Well Boring and Construction Logs

Appendix F – Track 2 Determination Letter

Appendix G – Excavation Work Plan

Appendix H – Site-Specific Health and Safety Plan

Appendix I – Site Management Forms

Appendix J – Quality Assurance Project Plan/Field Sampling Plan

**List of Acronyms**

AWQSGV	Ambient Water Quality Standards and Guidance Values
BCA	Brownfield Cleanup Agreement
BCP	Brownfield Cleanup Program
COC	Certificate of Completion
CVOC	Chlorinated Volatile Organic Compound
DD	Decision Document
DER	Division of Environmental Remediation
EC	Engineering Control
ECL	Environmental Conservation Law
EE	Environmental Easement
ESA	Environmental Site Assessment
EWP	Excavation Work Plan
FER	Final Engineering Report
FT BLS	Feet Below Land Surface
IC	Institutional Control
LBA	Louis Berger and Associates
MG/KG	Milligrams Per Kilogram
NAVD88	North American Vertical Datum of 1988
NYCACS	New York City Administration for Children’s Services
NYCDEP	New York City Department of Environmental Protection
NYCEDC	New York City Economic Development Corporation
NYS	New York State
NYSDEC	New York State Department of Environmental Conservation
NYSDOH	New York State Department of Health
PAH	Polycyclic Aromatic Hydrocarbon
PBS	Petroleum Bulk Storage
PFAS	Per- and Polyfluoroalkyl Substances
PGWSCO	Protection of Groundwater Soil Cleanup Objective
PCB	Polychlorinated Biphenyl
PID	Photoionization Detector
PRR	Periodic Review Report
QAPP/FSP	Quality Assurance Project Plan/Field Sampling Plan
QA/QC	Quality Assurance/Quality Control
RAO	Remedial Action Objective
RAP	Remedial Action Plan
RAWP	Remedial Action Work Plan
REC	Recognized Environmental Concern
RA	Remedial Action
RI	Remedial Investigation
RIWP	Remedial Investigation Work Plan
RIR	Remedial Investigation Report
RP	Remedial Party
RRSCO	Restricted Residential Soil Cleanup Objective
SCO	Soil Cleanup Objective

SF	Square Feet
SMP	Site Management Plan
SVI	Soil Vapor Intrusion
SVOC	Semivolatile Organic Compound
TAL	Target Analyte List
TCE	Trichloroethylene
TCL	Target Compound List
µg/L	Micrograms Per Liter
µg/m <sup>3</sup>	Micrograms Per Cubic Meter
USEPA	United States Environmental Protection Agency
UST	Underground Storage Tank
UUSCO	Unrestricted Use Soil Cleanup Objective
VOC	Volatile Organic Compound



**ES EXECUTIVE SUMMARY**

The following provides a brief summary of the controls implemented for the Site, as well as the inspections, monitoring, and reporting activities required by this Site Management Plan (SMP):

Site Identification:      BCP Site No. C203097  
    The Peninsula  
    1221 Spofford Avenue, Bronx, New York

Institutional Controls:	1. The property may be used for restricted residential, commercial, or industrial use as defined in NYCRR part 375-1.8(g). The property may not be used for high level uses such as unrestricted use or residential (single family) use without additional remediation and amendment of the Environmental Easement (EE), as approved by the Department.
	2. Environmental Easement.
	3. The use of groundwater underlying the property is prohibited without necessary water quality treatment as determined by the NYSDOH or the New York City Department of Health and Mental Hygiene to render it safe for use as drinking water or for industrial purposes, and the user must first notify and obtain written approval to do so from the Department.
	4. Environmental and/or public health monitoring must be performed as defined in this SMP.
	5. Data and information pertinent to Site management must be reported at the frequency and in a manner as defined in this SMP.
	6. All future activities that will disturb remaining contaminated material must be conducted in accordance with this SMP.
	7. Access to the Site must be provided to agents, employees or other representatives of the State of New York with reasonable prior notice to the property owner to assure compliance with the restrictions identified by the Environmental Easement.
	8. The potential for vapor intrusion must be evaluated for any buildings developed in the area within the IC boundaries noted on the figure included in the Environmental Easement (included in Appendix A), and appropriate actions to address exposures must be implemented.
	9. Vegetable gardens and farming on the Site are prohibited.

Site Identification:      BCP Site No. C203097  
                                     The Peninsula  
                                     1221 Spofford Avenue, Bronx, New York

Inspections:	Frequency
Site-Wide Inspection	Annually
Evaluations:	
Climate Change Vulnerability Assessment	As needed
Soil Vapor Intrusion (SVI) evaluation	Prior to occupancy of any building constructed within the IC boundaries.
Monitoring:	Frequency
Groundwater Monitoring	Two rounds of baseline groundwater sampling under the RAWP (third and fourth quarter 2020) have been collected following completion of remediation. Two additional quarters of groundwater monitoring will be conducted in the first and second quarter 2021 to one year of post-remediation groundwater monitoring.
Reporting:	
Inspections	Annually
Certification/PRR	Annually until completion of all construction activities. Frequency thereafter to be determined in consultation with the Department.

Further descriptions of the above requirements are provided in detail in the subsequent sections of this SMP.

## **1.0 INTRODUCTION**

### **1.1 General**

This Site Management Plan (SMP) is a required element of the remedial program for The Peninsula located in Bronx, New York (hereinafter referred to as the “Site”). See Figure 1. The Site is currently in the New York State (NYS) Brownfield Cleanup Program (BCP) Site No. C203097 which is administered by the New York State Department of Environmental Conservation (NYSDEC).

The Peninsula JV, LLC entered into a Brownfield Cleanup Agreement (BCA) on November 9, 2017 with the NYSDEC to remediate the Site. A figure showing the Site location and boundaries of this Site is provided in Figure 1. The boundaries of the Site are more fully described in the metes and bounds Site description that is part of the Environmental Easement provided in Appendix A.

After completion of the remedial work, some contamination remains at this Site, which is hereafter referred to as “remaining contamination”. Institutional Controls (ICs) have been incorporated into the Site remedy to control exposure to remaining contamination to ensure protection of public health and the environment. An Environmental Easement granted to the NYSDEC and recorded with the NYC Office of the City Register, requires compliance with this SMP and all ICs placed on the Site.

This SMP was prepared to manage remaining contamination at the Site until the Environmental Easement is extinguished in accordance with Environmental Conservation Law (ECL) Article 71, Title 36. This plan has been approved by the NYSDEC, and compliance with this plan is required by the grantor of the Environmental Easement and the grantor’s successors and assigns. This SMP may only be revised with the approval of the NYSDEC.

It is important to note that:

- This SMP details the Site-specific implementation procedures that are required by the Environmental Easement. Failure to properly implement the SMP is a

violation of the Environmental Easement, which is grounds for revocation of the Certificate of Completion (COC), release or closure letter;

- Failure to comply with this SMP is also a violation of ECL, 6NYCRR Part 375 and the BCA Index # C203097-10-17; Site # C203097 for the Site, and thereby subject to applicable penalties.

All reports associated with the Site can be viewed by contacting the NYSDEC or its successor agency managing environmental issues in NYS. A list of contacts for persons involved with the Site is provided in Appendix B of this SMP.

This SMP was prepared by Roux Environmental Engineering and Geology, D.P.C., on behalf of The Peninsula JV, LLC, in accordance with the requirements of the NYSDEC's Division of Environmental Remediation (DER)-10 ("Technical Guidance for Site Investigation and Remediation"), dated May, 2010, and the guidelines provided by the NYSDEC. This SMP addresses the means for implementing the ICs that are required by the Environmental Easement for the Site.

## **1.2 Revisions**

Revisions to this plan will be proposed in writing to the NYSDEC's project manager. Revisions will be necessary upon, but not limited to, the following occurring: a post-remedial removal of contaminated sediment or soil, or other significant change to the Site conditions. In accordance with the Environmental Easement for the Site, the NYSDEC will provide a notice of any approved changes to the SMP and append these notices to the SMP that is retained in its files.

## **1.3 Notifications**

Notifications will be submitted by the property owner to the NYSDEC, as needed, in accordance with NYSDEC's DER – 10 for the following reasons:

- Written 60-day advance notice of any proposed changes in Site use that are required under the terms of the BCA, 6NYCRR Part 375 and/or ECL.
- 7-day advance notice of any field activity associated with the remedial program.
- Written 15-day advance notice of any proposed ground-intrusive activity pursuant to the Excavation Work Plan (EWP).

Any change in the ownership of the Site or the responsibility for implementing this SMP will include the following notifications:

- At least 60 days prior to the change, the NYSDEC will be notified in writing of the proposed change. This will include a certification that the prospective purchaser/Remedial Party (RP) has been provided with a copy of the BCA, and all approved work plans and reports, including this SMP.
- Within 15 days after the transfer of all or part of the Site, the new owner’s name, contact representative, and contact information will be confirmed in writing to the NYSDEC.

Table 1 on the following page includes contact information for the above notification. The information on this table will be updated as necessary to provide accurate contact information. A full listing of Site-related contact information is provided in Appendix B.

**Table 1: Notifications\***

Name	Contact Information
NYSDEC Project Manager: Wendi Zheng	718-482-8541 <a href="mailto:wendi.zheng@dec.ny.gov">wendi.zheng@dec.ny.gov</a>
NYSDEC Regional HW Remediation Engineer: Jane O’Connell	718-482-4599 <a href="mailto:jane.oconnell@dec.ny.gov">jane.oconnell@dec.ny.gov</a>
NYSDEC, Site Control: Kelly Lewandowski	Chief, Site Control Section New York State Department of Environmental Conservation Division of Environmental Remediation 625 Broadway Albany NY 12233-7020  (518) 402-9543  <a href="mailto:kelly.lewandowski@dec.ny.gov">kelly.lewandowski@dec.ny.gov</a>
NYSDOH Project Manager: Melissa Doroski	914-654-7149 <a href="mailto:melissa.doroski@health.ny.gov">melissa.doroski@health.ny.gov</a>
NYSDOH Section Chief: Scarlett McLaughlin	914-654-7149 <a href="mailto:scarlett.mclaughlin@health.ny.gov">scarlett.mclaughlin@health.ny.gov</a>

\* Note: Notifications are subject to change and will be updated as necessary.

## **2.0 SUMMARY OF PREVIOUS REMEDIAL INVESTIGATIONS AND REMEDIAL ACTIONS**

### **2.1 Site Location and Description**

The Site is located in Bronx County, New York and is identified as Block 2738 and Lots 35, 36, and 37 on the New York City Tax Map (see Figure 1). The Site is an approximately 3.7348-acre area and is bounded by the Corpus Christi Monastery to the north, Spofford Avenue to the south, demapped Barretto Street to the east, and Tiffany Street to the west (see Figure 1 – Site Location Map). The boundaries of the Site are more fully described in Appendix A –Environmental Easement. The owner of the Site parcels at the time of issuance of this SMP is/are:

The City of New York  
c/o The New York City Economic Development Corporation  
One Liberty Plaza, 14<sup>th</sup> Floor  
New York, NY 10006  
Attn: Senior VP, Asset Management  
with a copy to: Senior VP, Land Use Department  
212-312-3800  
[AssetManagement@edc.nyc](mailto:AssetManagement@edc.nyc)

The Volunteer at the time of issuance of this SMP, which is the RP for implementing the SMP under the BCA, is:

The Peninsula JV, LLC  
Ed Broderick  
7 Jackson Walkway, Providence, RI 02903  
[ebroderick@gilbaneco.com](mailto:ebroderick@gilbaneco.com)

The Peninsula JV, LLC has a 99-year ground lease with the City of New York to develop the property. Information detailing the responsibilities of the owner and RP are included in Appendix C.

## **2.2 Physical Setting**

### **2.2.1 Land Use**

The Site consists of two buildings, building 1A (Lot 36) and building 1B (Lot 37), that are currently under construction and a neighboring vacant lot (Lot 35) that has undergone excavation as part of the Site's remediation and in preparation for future redevelopment of proposed buildings 2A and 2B. The foundation installation at buildings 1A and 1B is complete, and superstructure construction work will continue under this SMP. The construction of buildings 2A and 2B is scheduled to begin in 2021 and will be completed under this SMP. The Site is zoned as a manufacturing district (M1-2), a residential district (R7-2), and a special mixed use district (MX-17) and is currently undergoing redevelopment activities but will be used for mixed use residential, commercial, and light industrial including the construction of a vibrant live-work campus featuring affordable housing, community space, open/recreational space, industrial space, and retail space. Figure 2 shows the current layout of the Site.

The properties adjoining the Site, and in the neighborhood surrounding the Site, primarily include a monastery, parkland, multi-family housing, light commercial facilities, community services (La Peninsula Community Organization, Inc.) and industrial/manufacturing facilities. The properties immediately south of the Site include mixed use multi-family residential properties and commercial properties; the properties immediately north of the Site include the Corpus Christi Monastery; the properties immediately east of the Site include single-family residential properties; and the properties to the west of the Site include multi/single-family residential properties and commercial properties. There are several parks within a one-half-mile radius of the Site, including Julio Carballo Fields to the northeast and Hunts Point Playground to the southeast.

### **2.2.2 Geology**

Prior to remediation and the implementation of the remedial action work plan (RAWP), the soil beneath the Site consisted of historic fill material including fine to medium sand with varying amounts of coarse sand, silt, gravel, asphalt, brick, and concrete fragments approximately 7 feet below land surface (ft bls). Weathered bedrock was

observed at most locations above competent bedrock, at a thickness ranging from approximately 0.5 ft to 10 ft. Bedrock was identified at shallower depths in the northern and central portions of the Site and slopes downward in a southern direction. Bedrock consist of the Hartland Formation which generally contains muscovite-biotite-quartz schist and gneissic granite. The surface of competent bedrock ranges from approximately 5 to 15 ft bls. During the remediation, the historic fill at the Site was excavated and disposed of offsite. The remaining soil at the Site consists of fine to medium sand with varying amounts of coarse sand, silt, and gravel. In areas of the Site where deeper excavation was needed for remediation and/or to reach the required grades for building foundations, bedrock is exposed at grade with no soil overburden.

Geologic cross sections are shown in Figure 3. Site specific boring logs are provided in Appendix D.

### **2.2.3 Hydrogeology**

During the Remedial Investigation (RI), completed in 2018, groundwater was encountered at depths ranging from 1.12 to 21.39 ft bls (El. +53.50 to +23.74 ft North American Vertical Datum of 1988 [NAVD88]), based on a gauging event of 17 onsite monitoring wells completed on June 22, 2018. The average depth to groundwater was 9.16 ft bls (El. +35.12 ft NAVD 88). Based on groundwater elevations observed during the RI and local hydrogeology, groundwater is expected to flow in a southwestern to western direction and generally follows the topography of the bedrock. All monitoring wells were decommissioned and removed as part of the onsite remediation and construction activities.

A groundwater contour map is shown in Figure 4. Groundwater elevation measurements are provided in Table 2. Groundwater monitoring well boring and construction logs are provided in Appendix E.

## **2.3 Investigation and Remedial History**

The following narrative provides a remedial history timeline and a brief summary of the available project records to document key investigative and remedial milestones for



the Site. Full titles for each of the reports referenced below are provided in Section 7.0 - References.

The Site was the location of the former Spofford Juvenile Detention Facility, later renamed as Bridges Juvenile Center, which was in operation from 1956 to 2011. Based on a 1951 Sanborn® Fire Insurance Map, a stone cutting yard, a dwelling, and “coops” are depicted in the northwestern portion of the Site. Information contained in the 1927 and 1940 City Directory indicated that a ground floor laundry facility with second floor residential apartments (according to Sanborn maps) was located on the southeast side of the property along Spofford Avenue; the actual period of operation is unknown.

This section provides an overview of previous environmental-related activities completed at the Site, based on a review of readily available information and the following previously completed environmental reports:

- Work Plan for the Remedial Investigation of NYSDEC Spill Case #0812579, dated March 17, 2009;
- Remedial Investigation Report (RIR) prepared by Louis Berger & Associates (LBA), dated May 15, 2009;
- Remedial Action Plan (RAP) prepared by LBA, dated May 21, 2010;
- Phase I Environmental Site Assessment (ESA) prepared by Arcadis, Inc., dated June 3, 2016;
- Groundwater Monitoring and Remediation Report for the Fourth Quarter 2016 prepared by URS, dated January 25, 2017;
- Phase I ESA prepared by Roux, dated July 11, 2017;
- Phase II ESA prepared by Roux, dated August 10, 2017;
- Remedial Investigation Work Plan (RIWP) prepared by Roux, dated January 15, 2018;
- RIR prepared by Roux, dated October 22, 2018; and
- RAWP prepared by Roux, dated December 14, 2018.

A summary of findings from select reports, including the Site environmental history, is provided below. Subsections for the evaluation of soil, groundwater and soil vapor conditions are provided for each report, as applicable.

### **2.3.1 Remedial Action Plan (LBA 2010) (also includes 2009 Remedial Investigation by reference)**

The 2010 LBA RAP, prepared on behalf of the New York City Department of Juvenile Justice, documents the investigation and proposed remedy for a #2 fuel oil release (NYSDEC Spill #0812579) that occurred at the Site on February 18, 2009. Approximately 2,000 gallons of #2 fuel oil was released to the subsurface from two 12,000-gallon underground storage tanks (USTs) located in the southeast courtyard of the Site.

The LBA RAP also documents analytical data and findings from an RI that was implemented by LBA between March 23-27, 2009. During the LBA RI, petroleum contamination was found in subsurface soils immediately surrounding the two USTs. In addition, separate phase petroleum product was observed atop groundwater perched above bedrock at soil borings installed in the boiler room adjacent to the north of the USTs and the exterior lot adjacent to the USTs.

The RI concluded the following:

- Soil contamination, including petroleum-related volatile organic compounds (VOCs) and semivolatile organic compounds (SVOCs), existed at concentrations that exceeded prior established standards, (and the current Restricted Residential Soil Cleanup Objectives [RRSCOs], the anticipated Site use).
- The gravel sub-base of the concrete basement floor and the assumed gravel sub-base beneath the (presumed) UST vault likely provided a preferential pathway for the fuel oil release.
- Free product was present in the basement in the three borings SB-01B, SB-02, and SB-03 located closest to the vault.
- There were indications beneath the basement slab that a separate historical release occurred at the Site.
- Free product was observed in two exterior borings, SB-15 and SB-16, located approximately 3 feet east of the UST vault.
- Only localized pockets of perched water were observed and only beneath the basement; no groundwater was observed in the exterior borings.

As a result of the presence of separate phase petroleum product and extensive soil contamination, the 2010 LBA RAP proposed separate phase petroleum product recovery using dual-phase extraction and surfactant injection. Since contaminated soil would likely remain following implementation of the dual-phase extraction system, LBA concluded that

engineering controls (ECs) and ICs would be required to prevent unnecessary direct contact with the soil. This remedial approach was never implemented by LBA.

### **LBA RI Soil Conditions**

VOCs – Nine of the 27 soil samples collected as part of the LBA RI contained VOCs at a concentration above the NYSDEC Unrestricted Use Soil Cleanup Objectives (UUSCOs) and RRSCOs. Contaminants detected in exceeding concentrations included, but were not limited to, ethylbenzene, naphthalene, toluene, xylenes, and 1,2,4-trimethylbenzene. The highest VOC concentrations were detected at location SB-16A (15.5-16 ft bls):

- 1,2,4-trimethylbenzene – 790 milligrams per kilogram (mg/kg) (compared to 3.6 mg/kg UUSCOs, and 52 mg/kg RRSCOs);
- 1,3,5-trimethylbenzene – 180 mg/kg (compared to 8.4 mg/kg UUSCOs, and 52 mg/kg RRSCOs);
- Ethylbenzene – 120 mg/kg (compared to 1 mg/kg UUSCOs, and 41 mg/kg RRSCOs);
- Naphthalene – 390 mg/kg (compared to 12 mg/kg UUSCOs, and 100 mg/kg RRSCOs);
- n-butylbenzene – 60 mg/kg (compared to 12 mg/kg UUSCOs, and 100 mg/kg RRSCOs);
- n-propylbenzene – 110 mg/kg (compared to 3.9 mg/kg UUSCOs, and 100 mg/kg RRSCOs);
- sec-butylbenzene – 68 mg/kg (compared to 11 mg/kg UUSCOs, and 100 mg/kg RRSCOs);
- Toluene – 120 mg/kg (compared to 0.7 mg/kg UUSCOs, and 100 mg/kg RRSCOs); and
- Xylenes (total) – 730 mg/kg (compared to 0.26 mg/kg UUSCOs, and 100 mg/kg RRSCOs).

SVOCs – SVOCs exceeded the UUSCOs and RRSCOs in soil samples SB-18B and SB-20, located immediately to the north and west of the existing USTs. The SVOC analyte concentrations at SB-18B (18.5-19 ft bls) and SB-20 (17-17.5 ft bls) were relatively the same as reported respectively below:

- Benzo(a)anthracene – 28 mg/kg and 28 mg/kg, respectively (compared to 1 mg/kg [UUSCOs and RRSCOs]);
- Benzo(a)pyrene – 14 mg/kg and 16 mg/kg (compared to 1 mg/kg [UUSCOs and RRSCOs]);
- Benzo(b)fluoranthene – 21 mg/kg and 25 mg/kg (compared to 1 mg/kg [UUSCOs and RRSCOs]);

- Benzo(k)fluoranthene – 8.9 mg/kg and 9.5 mg/kg (compared to 0.8 mg/kg UUSCOs, and 3.9 mg/kg RRSCO);
- Chrysene – 23 mg/kg and 26 mg/kg (compared to 1 mg/kg UUSCOs, and 3.9 mg/kg RRSCO);
- Dibenzo(a,h)anthracene – 2.2 mg/kg and 2.3 mg/kg (compared to 0.33 mg/kg [UUSCOs, and RRSCO]);
- Indeno(1,2,3-cd)pyrene – 6 mg/kg and 6.4 mg/kg (compared to 0.5 mg/kg [UUSCOs and RRSCO]); and
- Naphthalene – 12 mg/kg at SB-18B (compared to 12 mg/kg UUSCOs).

### **LBA RI Groundwater Conditions**

Temporary groundwater monitoring wells TWP01 through TWP04 were installed at basement boring locations SB-05B, SB-08, SB-10 and SB-12, respectively. TPH concentrations in groundwater ranged from 2,700 micrograms per liter ( $\mu\text{g/L}$ ) in TWP03 to 6,500  $\mu\text{g/L}$  in TWP04. VOCs were detected in groundwater at all four locations at concentrations above the NYSDEC Ambient Water Quality Standards and Guidance Values (AWQSGVs). The only SVOC detected in groundwater at a concentration above the AWQSGVs was naphthalene at a concentration of 12  $\mu\text{g/L}$  in sample TWP03.

#### **2.3.2 Groundwater Monitoring and Remediation Report for the Fourth Quarter 2016 (URS, 2017)**

URS, on behalf of New York City Administration for Children’s Services (NYCACS), implemented a monthly separate phase petroleum product recovery program in September 2014 and quarterly groundwater sampling. An estimated 11.75 gallons of product was recovered between September 2014 and October 2016. Separate phase petroleum product was initially recovered using a peristaltic pump and by June 2015, the separate phase petroleum product thickness in the monitoring wells had decreased substantially enough to switch to using petroleum absorbent socks in monitoring wells MW-02, MW-03, MW-04, and MW-05 for recovery. However, due to the amount of separate phase petroleum product present at monitoring well MW-05, manual product recovery with a pump resumed in November 2015. From May through August 2016, no separate phase petroleum product was detected in this well but in October 2016, product was measured at a thickness of 0.05 feet.

Separate phase petroleum product was detected at monitoring well MW-06 in February 2016 and was detected monthly thereafter. A petroleum absorbent sock was installed in MW-06 in April 2016 and replaced monthly. During the October 2016 monitoring event product was not detected at MW-06.

Due to the continued presence of separate phase petroleum product in monitoring wells MW-02, MW-03, MW-04, and MW-05, groundwater was not sampled from these monitoring wells. Groundwater sampling occurred quarterly at MW-01. During the sampling round in October 2016, the following analytes were present at concentrations above the AWQSGVs:

- Benzene;
- Ethylbenzene;
- Total Xylenes;
- Isopropylbenzene;
- n-Propylbenzene;
- p-Isopropyltoluene;
- 1,2,4-Trimethylbenzene;
- 1,3,5- Trimethylbenzene;
- n-Butylbenzene; and
- Naphthalene.

Monitoring well MW-06 was also sampled for VOCs and SVOCs in 2016 when separate phase petroleum product was not present (January and October 2016). Neither VOCs nor SVOCs were detected above reporting limits during the sampling events, with the exception of one SVOC, naphthalene, which was detected at a concentration of 36 µg/L, above the AWQSGV of 10 µg/L during the January 2016 sampling event. Chlorinated volatile organic compounds (CVOCs) were not analyzed for in groundwater.

### **2.3.3 Phase I ESA prepared by Arcadis, Inc., dated June 3, 2016**

The purpose of the 2016 Arcadis Phase I ESA was to assess and document conditions and to identify potential environmental risks at the Site in advance of the New York City Economic Development Corporation's (NYCEDC) potential re-use of the

property (which was defined as Lot 35, 1221 Spofford Avenue, the former juvenile detention center).

According to the 2016 Arcadis Phase I ESA, the following Recognized Environmental Concerns (RECs) were identified for Lot 35, as quoted below:

- Known soil and groundwater impacts due to an approximately 2,000-gallon release of fuel oil from UST supply lines near the basement boiler room at the Site in 2009, which is currently undergoing monitoring and remediation, is considered a REC at the Site.
- Staining observed in the basement indicative of releases from items such as improperly stored universal waste batteries, storage of oil spill cleanup materials in the basement and parking lot, and significant quantities of improperly stored universal waste bulbs in the basement area is considered a REC at the Site.

The following de minimis conditions were reported in the 2016 Arcadis Phase I ESA, as quoted below:

- The presence of trash and possible investigation-derived waste in the center parking area.
- Laundry chemicals left behind the laundry room, janitorial products and building maintenance products left behind in closets, and sanitation products left behind in the kitchen areas.

#### 2.3.4 Roux Phase I ESA (2017)

Roux completed a Phase I ESA in 2017. As part of the ESA, the following environmental concerns were identified:

- Documented petroleum contamination in soil and groundwater as a result of the fuel oil release from UST supply lines located near the basement boiler room of the Spofford Juvenile Detention Center. Based on information reviewed by Roux, it was assumed that separate phase petroleum product and extensive soil contamination still exist at the Site.
- The following table summarized findings from NYSDEC Petroleum Bulk Storage (PBS) Records for the Site, which was registered under PBS#2-604085.

Tank ID	Tank Location	Tank Contents	Capacity (Gallons)	Status
1	Underground	#6 Fuel Oil	20,000	Closed-Removed 2002
2	Underground	#2 Fuel Oil	12,000	In Service
3	Underground	#2 Fuel Oil	12,000	In Service

Tank ID	Tank Location	Tank Contents	Capacity (Gallons)	Status
Diesel	Aboveground (in vault)	Diesel (generator)	5,000	Closed in Place 2002
Heat	Aboveground (in vault)	Closed – Removed	20,000	Closed in Place 2002

- Staining: Staining observed on the concrete basement floor was presumably associated with oil spills and cleanup materials, and other universal wastes (such as batteries or degreasers, electrical equipment, and lubricating oils).
- Historical Uses: The Site was occupied by a laundry facility, stone cutting yard and an asphalt paving contractor prior to being developed as a juvenile detention center. It is possible that potential undocumented releases from the operations may have impacted the subsurface conditions at the Site.

### 2.3.5 Roux Phase II ESA (2017)

In 2017, Roux completed a Phase II ESA for the Site. This investigation consisted of 6 soil borings with 12 soil samples, one sub-slab soil gas sample, and two soil vapor samples. Groundwater was not collected as part of this assessment. The results of the Phase II ESA and Roux's conclusions related to environmental conditions at the Site are summarized in the soil and soil vapor sections below.

#### Soil Conditions

Previous investigations indicated the presence of petroleum-related VOCs in soils at concentrations above UUSCOs, RRSCO and/or Protection of Groundwater Soil Cleanup Objectives (PGWSCOs) associated with releases from former tank systems and/or other Site uses. At the time the Phase II ESA was completed, Site soils had not been remediated since completion of prior investigations.

Several petroleum-related and historic fill-related SVOCs were detected in shallow soil (i.e., 0-2 ft bls) at concentrations above the UUSCOs, RRSCO and/or PGWSCOs. Arsenic was detected in soil at a concentration above UUSCOs, RRSCO, and PGWSCOs from one shallow soil sample. Copper, lead, and zinc were detected in soil at concentrations above UUSCOs but below RRSCO and PGWSCOs. There were no exceedances of UUSCOs, RRSCO, and/or PGWSCOs for VOCs during the Phase II ESA.

SVOCs - Seven SVOCs (benzo(a)anthracene, benzo(a)pyrene, benzo(b)fluoranthene, benzo(k)fluoranthene, chrysene, dibenzo(a,h)anthracene, and/or indeno(1,2,3-c,d)pyrene) were detected in three of the 19 samples, including the duplicate sample, at concentrations exceeding UUSCOs, and/or RRSCOs. Laboratory analytical data for the SVOC soil exceedances are summarized below.

- Benzo(a)anthracene was detected at concentrations ranging from 1.5 mg/kg to 4 mg/kg (compared to 1 mg/kg [UUSCOs and RRSCOs]).
- Benzo(a)pyrene was detected at concentrations ranging from 3.3 mg/kg to 3.5 mg/kg (compared to 1 mg/kg [UUSCOs and RRSCOs]).
- Benzo(b)fluoranthene was detected at concentrations ranging from 1.4 mg/kg to 4.8 mg/kg (compared to 1 mg/kg [UUSCOs and RRSCOs]).
- Benzo(k)fluoranthene was detected at concentrations ranging from 1.4 mg/kg to 1.5 mg/kg (compared to 0.8 mg/kg [UUSCOs]).
- Chrysene was detected at concentrations ranging from 1.3 mg/kg to 3.5 mg/kg, (compared to 1 mg/kg [UUSCOs]).
- Dibenzo(a,h)anthracene was detected at concentrations ranging from 0.54 mg/kg to 0.58 mg/kg (compared to 0.33 mg/kg [UUSCOs]).
- Indeno(1,2,3-c,d)pyrene was detected at concentrations ranging from 0.58 mg/kg and 2.5 mg/kg, (compared to 0.5 mg/kg [UUSCOs and RRSCOs]).

Metals - Four metals (arsenic, copper, lead and/or zinc) were detected in six of the 19 soil samples, including the duplicate sample, at concentrations exceeding UUSCOs, RRSCOs and/or PGWSCOs. Laboratory analytical data for soil exceedances for metals are summarized below.

- Arsenic was detected at a concentration of 18 mg/kg (compared to 13 mg/kg [UUSCOs] and 16 mg/kg [RRSCOs]).
- Copper was detected at concentrations of 64 mg/kg, 190 mg/kg and 72 mg/kg (compared to 50 mg/kg [UUSCOs]).
- Lead was detected at concentrations of 64 mg/kg and 150 mg/kg (compared to 63 mg/kg [UUSCOs]).
- Zinc was at concentrations ranging from 120 mg/kg to 1,200 mg/kg (compared to 109 mg/kg [UUSCOs]).

Pesticides - Three pesticides (4,4-DDD, 4,4-DDE and/or 4,4-DDT) were detected in three of the 19 samples, including the duplicate sample, at concentrations exceeding UUSCOs only. Laboratory analytical data for the soil exceedances for pesticides are summarized below.



- 4,4-DDD was detected at a concentration of 0.00457 mg/kg and 0.0616 mg/kg (compared to 0.0033 mg/kg [UUSCOs]).
- 4,4-DDE was detected at a concentration of 0.0766 mg/kg (compared to 0.0033 mg/kg [UUSCOs]).
- 4,4-DDT was at a concentration of 0.513 mg/kg (compared to 0.0033 mg/kg [UUSCOs]).

### **Soil Vapor Conditions**

Several petroleum-related VOCs and CVOCs were detected in soil vapor samples throughout the Site. Specifically, three petroleum-related VOCs were detected at elevated concentrations in the sub-slab soil gas sample (RXSS-1): benzene detected at a concentration of 377 micrograms per cubic meter ( $\mu\text{g}/\text{m}^3$ ), cyclohexane detected at a concentration of 20,200  $\mu\text{g}/\text{m}^3$ , and propylene detected at a concentration of 181  $\mu\text{g}/\text{m}^3$ . The source of the petroleum-related VOCs was likely attributed to the 2009 #2 fuel oil spill and/or other historic spills. One sample location (RXSV-2) contained concentrations of trichloroethylene (TCE) (1.75  $\mu\text{g}/\text{m}^3$ ) in soil vapor.

### **2.3.6 Remedial Investigation Report Results**

The following sections summarize soil, groundwater, and soil vapor quality data that was generated by Roux during the RI.

### **Soil Sampling Results**

A total of 55 soil samples, including three field duplicate soil samples, were collected from 24 soil boring locations and submitted for laboratory analysis as part of the RI. All analytical soil data was compared to the NYSDEC Subpart 375-6 UUSCOs, RRSCO, and PGWSCO, in order to evaluate Site-wide soil quality and to determine contamination in soil. A summary of soil quality results is provided in the below sections.

The evaluation of the soil analytical data collected during the RI as well as soil analytical data collected during previous investigations (i.e., 2009 investigation completed by LBA and 2017 Phase II ESA completed by Roux) indicated the following about the Site-wide soil conditions:

- VOCs were not detected in soil samples collected during the RI or Phase II ESA exceeding NYSDEC UUSCOs, RRSCO or PGWSCO.
- SVOCs, primarily polycyclic aromatic hydrocarbons (PAHs), commonly associated with historic fill, were detected in two shallow soil samples (0-2 ft interval) exceeding UUSCOs, RRSCO and/or PGWSCO during the RI. SVOCs exceeding UUSCOs, RRSCO and/or PGWSCO were detected in soil boring samples RXMW-5 (0-2 ft bls) and RXSB-13 (0-2 ft bls) completed during the RI.
- Metals were detected in Site-wide soil samples collected during the RI and the 2017 Phase II ESA. Eight metals (arsenic, barium, beryllium, chromium, copper, lead, mercury, and zinc) were detected in soil samples exceeding UUSCOs, RRSCO and/or PGWSCO during the RI.
- Polychlorinated biphenyls (PCBs) were not detected above reporting limits in soil samples collected during the RI and previous investigations.
- Pesticides and herbicides were not detected in soil samples collected during the RI and the 2017 Phase II ESA exceeding UUSCOs, RRSCO and/or PGWSCO with the exception of 4,4'-DDT, 4,4'-DDD, and 4,4'-DDE. 4,4'-DDT was detected at a concentration exceeding UUSCOs only in four soil samples (RXSB-13\_0-2, RXSB-16\_1-3, RXSB-17\_0-2, and RXSB-17\_0-2 duplicate) during the RI.

### **Semivolatile Organic Compounds in Soil**

SVOCs, primarily PAHs, were detected in soil at concentrations exceeding NYSDEC Soil Cleanup Objectives (SCOs) during the RI. A summary of the SVOC soil exceedances of NYSDEC SCOs is provided below:

- Benzo(a)anthracene was detected at concentrations exceeding NYSDEC UUSCOs, RRSCO and PGWSCO (1 mg/kg, respectively) in one soil sample (RXSB-13\_0-2) during the RI.
- Benzo(a)pyrene was detected at concentrations exceeding NYSDEC UUSCOs and RRSCO (1 mg/kg, respectively) in one soil sample (RXSB-13\_0-2) during the RI.
- Benzo(b)fluoranthene was detected at concentrations exceeding NYSDEC UUSCOs and RRSCO in one soil sample (RXSB-13\_0-2) at a concentration of 1.7 mg/kg compared to 1 mg/kg (UUSCOs and RRSCO, respectively).
- Chrysene was detected at concentrations exceeding NYSDEC UUSCOs and PGWSCO in one soil sample (RXSB-13\_0-2) at a concentration of 1.3 mg/kg compared to 1 mg/kg (UUSCOs and PGWSCO, respectively).
- Indeno(1,2,3-c,d)pyrene was detected at concentrations exceeding NYSDEC UUSCOs and RRSCO in two soil samples (RXMW-5\_0-2 and RXSB-13\_0-2) at a concentration of 0.52 mg/kg and 0.78 mg/kg, respectively, compared to 0.50 mg/kg (UUSCOs and RRSCO, respectively).

### **Metals in Soil**

Metals were detected in soil at concentrations exceeding NYSDEC SCOs during the RI. A summary of the soil exceedances of NYSDEC SCOs is provided below:

- Arsenic was detected at concentrations exceeding UUSCOs (13 mg/kg) in seven soil samples, and at concentrations exceeding RRSCOs/PGWSCOs (16 mg/kg, respectively) in six soil samples during this RI, ranging in concentration from 14.1 mg/kg to 55.7 mg/kg, with the maximum detection in soil sample RXSB-17\_0-2.
- Barium was detected at concentrations exceeding UUSCOs (350 mg/kg) in six soil samples, and at concentrations exceeding RRSCOs/PGWSCOs (400 mg/kg and 820 mg/kg, respectively) in four soil samples, ranging in concentration from 379 mg/kg to 855 mg/kg, with the maximum detection of 855 mg/kg in soil sample RXSB-16\_1-3.
- Beryllium was detected at a concentration exceeding UUSCOs (7.2 mg/kg) in one sample (RXSB-16\_1-3), with a concentration of 20.2 mg/kg.
- Hexavalent chromium was detected at concentrations exceeding UUSCOs (1 mg/kg) in one soil sample (RXMW-2\_13-15), but did not exceed RRSCOs or PGWSCOs, at a concentration of 1.1 mg/kg.
- Total chromium was detected at concentrations exceeding UUSCOs in 23 soil samples, and at a concentration exceeding RRSCOs in one sample (RXSB-16\_1-3), ranging in concentration from 30.1 mg/kg to 344 mg/kg.
- Copper was detected at concentrations exceeding UUSCOs (50 mg/kg) in 30 soil samples, at concentrations exceeding RRSCOs (270 mg/kg) in 11 soil samples, and at concentrations exceeding PGWSCOs (1,720 mg/kg) in two samples during the RI.
- Lead was detected at concentrations exceeding UUSCOs (63 mg/kg) in 25 soil samples, at concentrations exceeding RRSCOs (400 mg/kg) in six soil samples, and at concentrations exceeding PGWSCOs (450 mg/kg) in five soil samples during the RI, ranging in concentration from 64 mg/kg to 4,010 mg/kg, with the maximum detection in soil sample RXSB-16\_1-3.
- Mercury was detected at concentrations exceeding UUSCOs (0.18 mg/kg) in two soil samples, at a concentration of 0.34 mg/kg (RXMW-2\_0-2) and 0.65 mg/kg (RXSB-13\_0-2).
- Nickel was detected at concentrations exceeding UUSCOs (30 mg/kg) in 24 soil samples, at a concentration exceeding RRSCOs (310 mg/kg) in one sample, and at a concentration exceeding PGWSCOs (130 mg/kg) in one sample, ranging in concentration from 30.1 mg/kg to 487 mg/kg, with the maximum detection in soil sample RXSB-16\_0-2.
- Zinc was detected at concentrations exceeding UUSCOs (109 mg/kg) in 27 soil samples, at a concentration exceeding RRSCOs (10,000 mg/kg) in one sample, and at concentrations exceeding PGWSCOs (2,480 mg/kg) in seven samples during the RI, ranging in concentration from 114 mg/kg to 36,000 mg/kg, with the maximum detection in soil sample RXSB-16\_1-3.

## **Pesticides and Herbicides in Soil**

Pesticides and herbicides were detected in soil at concentrations exceeding NYSDEC SCOs during the RI. A summary of the soil exceedances of NYSDEC SCOs is provided below:

- 4,4'-DDT was detected at concentrations exceeding UUSCOs (0.0033 mg/kg) in four soil samples collected during the RI.

## **Groundwater Sampling Results**

A total of 17 groundwater samples and one field duplicate sample were collected from 17 monitoring wells and submitted for laboratory analysis as part of the RI. All analytical groundwater data was compared to NYSDEC AWQSGVs in order to evaluate groundwater quality and to determine the contamination in groundwater, if present.

The evaluation of the groundwater analytical data indicated the following about the Site-wide groundwater conditions:

- VOCs were detected marginally above the AWQSGVs at four monitoring well locations. Exceedances included chloroform at RXMW-1 located along the Tiffany Street sidewalk, ethylbenzene at MW-1 and MW-2 located directly adjacent to the former petroleum source area, isopropylbenzene at MW-2, and Tert-Butyl Methyl Ether at MW-6, located in the southeastern corner of the Site, adjacent to Spofford Avenue.
- SVOCs were detected in five groundwater samples from MW-1, MW-2, RXMW-4, RXMW-6, and RXMW-7 (all located in the southeast courtyard) but did not exceed NYSDEC AWQSGVs.
- Metals including aluminum, barium, calcium, iron, magnesium, manganese, potassium, and sodium were detected in all dissolved groundwater samples. Four metals, including iron, magnesium, manganese, and/or sodium exceeded the NYSDEC AWQSGVs in the filtered groundwater samples. Antimony exceeded the NYSDEC AWQSGVs in one unfiltered only groundwater sample. Lead exceeded the NYSDEC AWQSGVs in one unfiltered only groundwater sample.
- Pesticides and herbicides were not detected above laboratory reporting limits in any groundwater sample.
- PCBs were not detected above laboratory reporting limits in any groundwater sample.
- Per- and polyfluoroalkyl substances (PFAS) were detected in four groundwater samples, including a duplicate sample, during the RI. A total of 13 PFAS were detected in groundwater. There are currently no NYSDEC groundwater standards for PFAS.

## Soil Vapor Sampling Results

A total of nine soil vapor samples and four sub-slab soil vapor samples were collected and submitted for laboratory analysis as part of the RI.

A summary of soil vapor quality results is provided in the below sections. Analytical data for soil vapor indicated that there were detections of 32 different VOCs across the Site, including petroleum-related and chlorinated compounds, and is summarized below:

- Benzene was detected in four soil vapor samples, ranging in concentration from 1.5  $\mu\text{g}/\text{m}^3$  and 6.0  $\mu\text{g}/\text{m}^3$ , with the maximum concentration detected from sample RXSV-11.
- Ethylbenzene was detected in two soil vapor samples, RXSV-12 and RXSV-13 (located in the Tiffany Street sidewalk), at a concentration of 57  $\mu\text{g}/\text{m}^3$  and 2.2  $\mu\text{g}/\text{m}^3$ , respectively.
- Toluene was detected in six soil vapor samples and one sub-slab soil vapor sample, ranging in concentration from 2.9  $\mu\text{g}/\text{m}^3$  to 150  $\mu\text{g}/\text{m}^3$ , with the maximum concentration detected in RXSV-14 (located in Tiffany Street sidewalk).
- Xylenes (total) were detected in three soil vapor samples, RXSV-12, RXSV-13, and RXSV-14 (all located in the Tiffany Street sidewalk), at a concentration of 340  $\mu\text{g}/\text{m}^3$ , 7.4  $\mu\text{g}/\text{m}^3$  and 32  $\mu\text{g}/\text{m}^3$ , respectively.
- N-Hexane was detected in three soil vapor samples and one sub-slab soil vapor sample, ranging in concentration from 4.8  $\mu\text{g}/\text{m}^3$  to 2,500  $\mu\text{g}/\text{m}^3$ , with the maximum concentration detected in sample RXSS-4.
- 2,2,4-Trimethylpentane was detected in two soil vapor samples and two sub-slab soil vapor samples, ranging in concentration from 5.1  $\mu\text{g}/\text{m}^3$  to 3,800  $\mu\text{g}/\text{m}^3$ , with the maximum concentration detected in sample RXSS-4.
- 1,1-DCE was detected in one soil vapor sample, RXSV-9, at a concentration of 1.6  $\mu\text{g}/\text{m}^3$ , which was well below the NYSDOH Soil Vapor/Indoor Air Matrix A action level of 6  $\mu\text{g}/\text{m}^3$ .
- Carbon Tetrachloride was detected in two soil vapor samples, RXSV-12 and RXSV-13 (located in the Tiffany Street sidewalk), at a concentration of 0.56  $\mu\text{g}/\text{m}^3$  and 0.39  $\mu\text{g}/\text{m}^3$ , respectively. These concentrations were well below the NYSDOH Soil Vapor/Indoor Air Matrix A action level of 6  $\mu\text{g}/\text{m}^3$ .
- TCE was detected in two soil vapor samples and two sub-slab soil vapor samples, ranging in concentration from 1.2  $\mu\text{g}/\text{m}^3$  and 25  $\mu\text{g}/\text{m}^3$ , with the maximum concentration detected in sample RXSS-4. The TCE concentration at RXSS-4 was 25  $\mu\text{g}/\text{m}^3$ .

- PCE was detected in nine soil vapor samples and one sub-slab soil vapor sample, ranging in concentration from 4.1  $\mu\text{g}/\text{m}^3$  to 46  $\mu\text{g}/\text{m}^3$ , with the maximum concentration detected from sample RXSV-12 (located on Tiffany Street sidewalk).

## **2.4 Remedial Action Objectives**

The Remedial Action Objectives (RAOs) for the Site as listed in the Decision Document (DD) dated December 17, 2018 are as follows.

### **2.4.1 Groundwater**

RAOs for Public Health Protection

- Prevent ingestion of groundwater with contaminant levels exceeding drinking water standards.
- Prevent contact with, or inhalation of, volatiles from contaminated groundwater.

RAOs for Environmental Protection

- Restore ground water aquifer to pre-disposal/pre-release conditions, to the extent practicable.
- Remove the source of ground or surface water contamination.

### **2.4.2 Soil**

RAOs for Public Health Protection

- Prevent ingestion/direct contact with contaminated soil.
- Prevent inhalation of or exposure from contaminants volatilizing from contaminants in soil.

RAOs for Environmental Protection

- Prevent migration of contaminants that would result in groundwater or surface water contamination.

### **2.4.3 Soil Vapor**

RAOs for Public Health Protection

- Mitigate impacts to public health resulting from existing, or the potential for, soil vapor intrusion into buildings at a site.

## 2.5 Remaining Contamination

### 2.5.1 Soil

The Remedial Action (RA) for this Site achieved a Track 2 Restricted Residential remedy through the excavation of fill material, excavation of soil in areas of the Site identified during the RI as exceeding RRSCOs and/or PGWSCOs, removal of USTs, and excavation of petroleum-contaminated soil associated with the former petroleum source area and closure of spill # 0812579. In accordance with the NYSDEC-approved RAWP, 119 post-excavation endpoint samples and seven duplicate samples were collected at a frequency of 1 sample per 2,000 square feet (SF) to determine that Track 2 SCOs were achieved. In areas where the excavation extended to competent bedrock, no endpoint samples were collected and bedrock was swept clean of all soils and photo documented. All endpoint samples were collected for the following parameters, with the exception of former petroleum source area sidewall samples which were analyzed for Target Compounds List (TCL)/Part 375 VOCs and TCL/Part 375 SVOCs only:

- TCL/Part 375 VOCs;
- TCL/Part 375 SVOCs;
- Target Analyte List (TAL) Metals + Mercury;
- Hexavalent/Trivalent Chromium;
- PCBs;
- TCL/Part 375 Pesticides; and
- Part 375 Herbicides.

The following endpoint samples exceeded RRSCOs :

Sample ID	Sample Depth (ft bls)	Confirmation Endpoint Sample Type	Compound Group	Compounds Exceeding RRSCOs and/or PGWSCOs	Remaining Concentration (mg/kg)	RRSCO (mg/kg)	PGWSCO (mg/kg)
1A-EP-B-1	9 - 11	Bottom	SVOCs	Indeno(1,2,3-c,d)pyrene	1.1	0.5	8.2
1A-EP-SW-4	0 - 1	Sidewall	SVOCs	Benzo(b)fluoranthene	1.1	1	1.7
				Indeno(1,2,3-c,d)pyrene	0.56	0.5	8.2
			Metals	Copper	304	270	1,720
1B-EP-SW-8	0 - 1	Sidewall	SVOCs	Benzo(b)fluoranthene	1.1	1	1.7

Sample ID	Sample Depth (ft bls)	Confirmation Endpoint Sample Type	Compound Group	Compounds Exceeding RRSCOs and/or PGWSCOs	Remaining Concentration (mg/kg)	RRSCO (mg/kg)	PGWSCO (mg/kg)
2A-EP-SW-3	0 - 1	Sidewall	SVOCs	Benzo(b)fluoranthene	1.1	1	1.7
				Indeno(1,2,3-c,d)pyrene	0.58	0.5	8.2
2A-EP-B-20	0 - 1	Bottom	Metals	Copper	304	270	1,720
2B-EP-B-2	0 - 1	Bottom	SVOCs	Benzo(a)anthracene	1.4	1	1
				Benzo(a)pyrene	1.2	1	22
				Benzo(b)fluoranthene	1.8	1	1.7
				Chrysene	1.3	3.9	1
2B-EP-B-28	0 - 1	Bottom	Metals	Copper	322	270	1,720
2B-EP-B-31	0 - 1	Bottom	Metals	Barium	562	400	820
2B-EP-B-6	0 - 1	Bottom	Metals	Copper	406	270	1,720

In a letter dated September 15, 2020, the Department determined that, in accordance with DER-10 5.4(b)(2)(i), the excavation has achieved the Track 2 RAOs. A copy of the letter is included in Appendix F.

No bottom endpoint samples were collected from the southern portion of the former petroleum source area since soil excavation was extended down to competent bedrock, broom swept clean of all soil, and photo documented. Three bottom endpoint samples were collected from weathered bedrock in the northern portion of the former petroleum source area. All bottom and sidewall endpoint samples in the former petroleum source area yielded results below UUSCOS with the exception of the one acetone exceedance.

Tables 3 through 6 and Figure 5 summarize the results of all soil samples collected that exceed the UUSCOs and the lower of RRSCOs and/or PGWSCOs at the Site after completion of the RA.

### 2.5.1.1 Excavation for Future Redevelopment

The Site is split into two portions, Phase 1 and Phase 2. Phase 1 makes up the western portion of the Site and contains buildings 1A and 1B, which were constructed under the RAWP. Phase 2 makes up the eastern portion of the Site and is the future location of buildings 2A and 2B. Construction of buildings 2A and 2B is anticipated to begin in mid-2021, under this SMP. In the event that excavation is needed for the construction of future buildings 2A and 2B, the excavation work will be completed with the EWP. The EWP is



provided in Appendix G and outlines the procedures to be implemented during potential future onsite excavation. Since the Site received a Track 2 RRSCOs by way of endpoint sampling, visual, olfactory, and instrument-based (e.g. PID) soil screening will only be performed during soil characterization and loadout, unless unexpected conditions are encountered in the form grossly contaminated soil or groundwater. In the event that the screening is required, visual, olfactory, and instrument based (e.g. PID) soil screening will be completed by a qualified environmental professional.

### **2.5.2 Groundwater**

Groundwater contamination has been remediated through excavation and offsite disposal of soil from the former petroleum source area, excavation of fill material, and excavation of soil exceeding RRSCOs and/or PGWSCOs. Excavation within the former petroleum source area and directly downgradient was extended to competent or weathered bedrock. The underlying bedrock did not exhibit signs of impact (odor, staining, PID readings, etc.). As discussed in the NYSDEC-approved RAWP, two bedrock monitoring wells and two rounds of baseline groundwater samples (semi-annual) were required following the completion of remedial excavation activities. As approved by NYSDEC via e-mail on June 25, 2020, two bedrock monitoring wells, BRMW-1 and BRMW-2, were installed downgradient of the former petroleum source area on July 8, 2020. The locations of BRMW-1 and BRMW-2 are included in Figure 6 – Monitoring Well Network. Groundwater samples and associated quality assurance/quality control (QA/QC) samples (duplicate, matrix spike/matrix spike duplicate, field blank, and trip blank) were collected during the BRMW-1 and BRMW-2 sampling event on July 15, 2020 and analyzed for TCL VOCs. The groundwater samples collected did not yield any exceedances of AWQSGVs. The second BRMW-1 and BRMW-2 baseline groundwater sampling event was completed on October 8, 2020. Groundwater samples from BRMW-1 and BRMW-2, as well as a trip blank, were collected and analyzed for TCL VOCs. The groundwater samples collected during the second baseline sampling event did not yield any exceedances of AWQSGVs. Additional rounds of groundwater sampling will be completed in the first quarter and second quarter of 2021, after receipt of the COC. In accordance with New York City Department of Environmental Protection (NYCDEP) discharge permits #889957,

#887686, and #898250, groundwater removed from the excavations was treated via onsite groundwater dewatering systems and discharged to the combined municipal sewer system at the Site.

### **2.5.3 Soil Vapor**

The onsite soil vapor contamination was addressed during the RA through the completion of the former petroleum source area soil removal, which was extended down to competent or weathered bedrock. In areas where excavation extended to weathered bedrock, bottom endpoint samples were collected that yielded analytical results below UUSCOs. During the RA, all soil was excavated in the area of sub-slab soil vapor sample RXSS-4 down to weathered bedrock. All endpoint samples in the area of RXSS-4 met the lower of RRSCO and PGWSCO. In accordance with the RAWP, soil vapor mitigation will include a 20-mil vapor barrier or waterproofing membrane integrated into the building foundation and a subgrade parking garage with a high exchange ventilation system. A soil vapor intrusion (SVI) evaluation must be performed upon a change in use of the property that will result in occupancy of a previously unoccupied building or initial occupancy of a new building. The breadth of this evaluation will be determined based upon discussion with the NYSDEC Project Manager and NYSDOH.

### **3.0 INSTITUTIONAL CONTROL PLAN**

#### **3.1 General**

Since remaining contamination exists at the Site, ICs are required to protect human health and the environment. This IC Plan describes the procedures for the implementation and management of all ICs at the Site. The IC Plan is one component of the SMP and is subject to revision by the NYSDEC.

This plan provides:

- A description of all ICs on the Site;
- The basic implementation and intended role of each IC;
- A description of the key components of the ICs set forth in the Environmental Easement;
- A description of the controls to be evaluated during each required inspection and periodic review;
- Any other provisions necessary to identify or establish methods for implementing the ICs required by the Site remedy, as determined by the NYSDEC.

#### **3.2 Institutional Controls**

A series of ICs is required by the DD to: (1) prevent future exposure to remaining contamination; and, (2) limit the use and development of the Site to restricted residential, commercial, and industrial uses. Adherence to these ICs on the Site is required by the Environmental Easement and will be implemented under this SMP. ICs identified in the Environmental Easement may not be discontinued without an amendment to or extinguishment of the Environmental Easement. The IC boundaries are shown on the figure included in the Environmental Easement (included in Appendix A). These ICs are:

- The property may be used for: restricted residential, commercial, and industrial use;
- The use of groundwater underlying the property is prohibited without necessary water quality treatment as determined by the NYSDOH or the New York City Department of Health and Mental Hygiene to render it safe for use as drinking water or for industrial purposes, and the user must first notify and obtain written approval to do so from the Department;

- Environmental and/or public health monitoring must be performed as defined in this SMP;
- Data and information pertinent to Site management must be reported at the frequency and in a manner as defined in this SMP;
- All future activities that will disturb remaining contaminated material must be conducted in accordance with this SMP;
- Access to the Site must be provided to agents, employees or other representatives of the State of New York with reasonable prior notice to the property owner to assure compliance with the restrictions identified by the Environmental Easement;
- The potential for vapor intrusion must be evaluated for any buildings developed in the area within the IC boundaries noted on the figure included in the Environmental Easement (included in Appendix A), and appropriate actions to address exposures must be implemented; and
- Vegetable gardens and farming on the Site are prohibited;

### **3.3 Site – wide Inspection**

Site-wide inspections will be performed at a minimum of once per year. Modification to the frequency or duration of the inspections will require approval from the NYSDEC. Site-wide inspections will also be performed after all severe weather conditions that may affect the remaining contamination at the Site. A comprehensive Site-wide inspection will be conducted and documented according to the SMP schedule, regardless of the frequency of the Periodic Review Report (PRR).

During an inspection, an inspection form will be completed as provided in Appendix I – Site Management Forms. The inspections will determine and document the following:

Compliance with all ICs, including Site usage;

- General Site conditions at the time of the inspection;
- The Site management activities being conducted including, where appropriate, confirmation sampling and a health and safety inspection;
- If these controls continue to be protective of human health and the environment;
- Compliance with requirements of this SMP and the Environmental Easement; and
- If Site records are complete and up to date.

Reporting requirements are outlined in Section 6.0 of this plan.

Inspections will also be performed in the event of an emergency. An inspection of the Site will be conducted within 5 days of the event to verify the effectiveness of the ICs implemented at the Site by a qualified environmental professional, as determined by the NYSDEC. Written confirmation must be provided to the NYSDEC within 7 days of the event that includes a summary of actions taken, or to be taken, and the potential impact to the environment and the public.

## **4.0 MONITORING AND SAMPLING PLAN**

### **4.1 General**

This Monitoring and Sampling Plan describes the measures for evaluating the overall performance and effectiveness of the remedy. This Monitoring and Sampling Plan may only be revised with the approval of the NYSDEC. Details regarding the sampling procedures, data quality usability objectives, analytical methods, etc. for all samples collected as part of management for the Site are included in the Quality Assurance Project Plan/Field Sampling Plan (QAPP/FSP) provided in Appendix J.

This Monitoring and Sampling Plan describes the methods to be used for post-remediation groundwater sampling. Monitoring of the performance of the remedy and overall reduction in contamination onsite will be conducted for one year following completion of the RA. The first two quarterly sampling events were completed after the completion of the RA and prior to the receipt of the COC. The remaining two quarterly sampling events will be completed after receipt of the COC.

The frequency thereafter will be determined in consultation with NYSDEC and based on reports submitted showing contaminant trends. Trends in contaminant levels in groundwater will be evaluated to determine if the remedy continues to be effective in achieving remedial goals. If the sample results demonstrate attainment of the AWQSGVs or bulk reduction in groundwater concentrations compared to the RI groundwater results, no further monitoring will be conducted. A record of the findings of each monitoring event will be documented on the Site Management Forms, included in Appendix I.

### **4.2 Groundwater Monitoring**

Samples will be collected from groundwater monitoring wells to evaluate the effectiveness of source area soil removal, and to confirm that the remedy was completed. Bedrock monitoring well locations, the required analytical parameters, and schedule are provided in Section 4.2.1 and on Figure 6. Modification to the frequency or sampling requirements will require approval from the NYSDEC. Detailed sample collection and analytical procedures and protocols are provided in the QAPP/FSP, included in Appendix J.

#### 4.2.1 Groundwater Sampling

Groundwater monitoring will be performed quarterly for one year following successful completion of the RA to assess the performance of the remedy. The first two quarterly groundwater sampling events were completed in July 2020 and October 2020, prior to receipt of the COC. The remaining two quarterly groundwater sampling events will be completed in the first and second quarters of 2021. All data generated during the first two quarterly groundwater sampling events has been provided to NYSDEC. Modification to the frequency or sampling requirements will require approval from the NYSDEC.

Samples will be collected from bedrock monitoring wells, installed under the NYSDEC-approved RAWP as shown on Figure 6. Bedrock monitoring well locations were approved by NYSDEC via e-mail on June 25, 2020. Monitoring well construction logs are included in Appendix E. The monitoring wells will be sampled for the TCL VOCs in accordance with the NYSDEC-approved RAWP.

Purge water and decontamination water generated during groundwater sampling will be containerized, properly labeled, and disposed of. The sampling, sample handling, decontamination, and field instrument calibration procedures will be performed in accordance with the analytical procedures and protocols provided in the QAPP/FSP, included in Appendix J.

If biofouling or silt accumulation occurs in the onsite monitoring wells, the wells will be physically agitated/surged and redeveloped. Additionally, monitoring wells will be properly decommissioned and replaced, if an event renders the wells unusable.

Repairs and/or replacement of wells in the monitoring well network will be performed based on assessments of structural integrity and overall performance.

The NYSDEC will be notified prior to any repair or decommissioning of any monitoring well for the purpose of replacement, and the repair or decommissioning and replacement process will be documented in the subsequent PRR. Well decommissioning without replacement will be done only with the prior approval of the NYSDEC. Well abandonment will be performed in accordance with NYSDEC's guidance entitled "CP-43:

Groundwater Monitoring Well Decommissioning Procedures.” Monitoring wells that are decommissioned because they have been rendered unusable will be replaced in kind in the nearest available location, unless otherwise approved by the NYSDEC.

Deliverables for the groundwater monitoring program are specified in Section 6.0 – Reporting Requirements.



## **5.0 PERIODIC ASSESSMENTS/EVALUATIONS**

### **5.1 Climate Change Vulnerability Assessment**

Increases in both the severity and frequency of storms/weather events, an increase in sea level elevations along with accompanying flooding impacts, shifting precipitation patterns and wide temperature fluctuation, resulting from global climactic change and instability, have the potential to significantly impact the performance, effectiveness and protectiveness of a given site and associated remedial systems. Vulnerability assessments provide information so that the Site is prepared for the impacts of the increasing frequency and intensity of severe storms/weather events and associated flooding.

This section provides a summary of vulnerability assessments that will be conducted for the Site during periodic assessments, and briefly summarizes the vulnerability of the Site to severe storms/weather events and associated flooding.

#### **5.1.1 Flood Plain**

Federal 100-year and 500-year flood zones are depicted at approximately 1/2-mile to the south and east of the Site, which lies in the northwest portion of a peninsula formed by the Bronx River (to the east) and the East River (to the south). Due to the Site's distance from the extent of the flood zones, the Site is not expected to be impacted by flooding events.

#### **5.1.2 Erosion**

The Site will be primarily covered by buildings, pavement, and stabilized landscaping which will prevent erosion from becoming an issue in the event of flooding or severe weather events. Erosion and sediment control measures will be implemented during all intrusive work during future Site redevelopment.

#### **5.1.3 Electricity**

There are no remedial aspects of the Site that would be affected in the event of an electricity outage.

#### **5.1.4 Site Drainage and Storm Water Management**

There are no areas of the Site that are susceptible to flooding during severe weather events. Stormwater onsite and in the surrounding area is serviced solely by combined sewers via catch basins near the Site.

#### **5.1.5 High Wind**

There are no aspects of the Site that would be affected by high winds during a severe weather event.

#### **5.1.6 Spill/Contaminant Release**

No areas of the Site have been identified that may be susceptible to a spill or other contaminant release due to storm-related damage caused by flooding, erosion, high winds, loss of power, etc.

### **5.2 Soil Vapor Intrusion Evaluation**

An SVI evaluation must be performed upon a change in use of the property that will result in occupancy of a previously unoccupied building or initial occupancy of a new building. The breadth of this evaluation will be determined based upon discussion with the NYSDEC project manager and NYSDOH. Based upon these discussions and agency requirements, a work plan may need to be developed that requires that sampling be performed.

Upon completion of the evaluation, if an action is required, any actions taken or to be taken must be reflected in an updated SMP.

**6.0. REPORTING REQUIREMENTS**

**6.1 Site Management Reports**

All Site management inspection events will be recorded on the appropriate Site management forms provided in Appendix I. These forms are subject to NYSDEC revision.

All applicable inspection forms and other records, including media sampling data generated for the Site during the reporting period will be provided in electronic format to the NYSDEC in accordance with the requirements of Table 6 and summarized in the PRR.

**Table 6: Schedule of Inspection Reports**

<b>Task/Report</b>	<b>Reporting Frequency*</b>
Inspection Report	Annually
Periodic Review Report	Annually until completion of all construction activities. Frequency thereafter to be determined in consultation with the Department.

\* The frequency of events will be conducted as specified until otherwise modified by the NYSDEC.

All inspection reports will include, at a minimum:

- Date of event or reporting period;
- Name, company, and position of person(s) conducting monitoring/inspection activities;
- Description of the activities performed;
- Where appropriate, color photographs or sketches showing the approximate location of any problems or incidents noted (included either on the checklist/form or on an attached sheet);
- Any observations, conclusions, or recommendations; and
- A determination as to whether contaminant conditions have changed since the last reporting event.

Non-routine event reporting forms will include, at a minimum:

- Date of event;
- Name, company, and position of person(s) conducting non-routine maintenance/repair activities;
- Description of non-routine activities performed; and
- Where appropriate, color photographs or sketches showing the approximate location of any problems or incidents (included either on the form or on an attached sheet).

## **6.2 Periodic Review Report**

The PRR will consist only of the certification as specified in Section 5.2.1 except in the event where there have been changes to the Site or data gathered during the certifying period, including groundwater sampling. Given such an event, the submittal of a comprehensive PRR will be necessary, as specified below.

A PRR will be submitted to the Department beginning 30 days after the initial 15 month certifying period. This initial certifying period commences upon issuance of the COC. After submittal of the initial PRR, the next PRR shall be submitted annually until completion of all construction activities. Frequency thereafter to be determined in consultation with the Department. In the event that the Site is subdivided into separate parcels with different ownership, a single PRR will be prepared that addresses the Site described in Appendix A - Environmental Easement. The report will be prepared in accordance with NYSDEC's DER-10 and submitted within 30 days of the end of each certification period. Media sampling results will also be incorporated into the PRR. The report will include:

- Identification, assessment and certification of all ICs required by the remedy for the Site.
- Results of the required annual Site inspections and severe condition inspections, if applicable.
- All applicable Site management forms and other records generated for the Site during the reporting period in the NYSDEC-approved electronic format, if not previously submitted.
- A summary of any data and/or information generated during the reporting period, with comments and conclusions, if any.
- A Site evaluation, which includes the following:

- The compliance of the remedy with the requirements of the Site-specific RAWP or DD;
- Any new conclusions or observations regarding Site contamination based on inspections or data generated;
- Recommendations regarding any necessary changes to the remedy; and
- The overall performance and effectiveness of the remedy.

### 6.2.1 Certification of Institutional Controls

Within 30 days after the end of each certifying period, as determined by the NYSDEC, the following certification will be provided to the Department:

*“For each institutional control identified for the Site, I certify that all of the following statements are true:*

- *The institutional control employed at this Site is unchanged from the date the control was put in place, or last approved by the Department;*
- *Nothing has occurred that would impair the ability of the control to protect the public health and environment;*
- *Nothing has occurred that would constitute a violation or failure to comply with any Site management plan for this control;*
- *Access to the Site will continue to be provided to the Department to evaluate the remedy, including access to evaluate the continued maintenance of this control;*
- *Use of the Site is compliant with the environmental easement.*
- *The information presented in this report is accurate and complete.*

*I certify that all information and statements in this certification form are true. I understand that a false statement made herein is punishable as a Class “A” misdemeanor, pursuant to Section 210.45 of the Penal Law. I, Brian P. Morrissey, of Roux Environmental Engineering and Geology, D.P.C., am certifying as Owner’s Designated Site Representative and I have been authorized and designated by all Site owners to sign this certification for the Site.”*

- *No new information has come to my attention, including groundwater monitoring data from wells located at the Site boundary, if any, to indicate that the assumptions made in the qualitative exposure assessment of offsite contamination are no longer valid; and*

For BCP projects, every five years the following certification will be added:

- *The assumptions made in the qualitative exposure assessment remain valid.*

The signed certification will be included in the PRR, if such report is required for the period. Otherwise, the Certification will be submitted as a stand-alone document.

The PRR/Certification will be submitted, in electronic format, to the NYSDEC Central Office, the NYSDEC Regional Office in which the Site is located and the NYSDOH Bureau of Environmental Exposure Investigation. The PRR/Certification may need to be submitted in hard-copy format, as requested by the NYSDEC project manager.

### **6.3 Corrective Measures Work Plan**

If any component of the remedy is found to have failed, or if the periodic certification cannot be provided due to the failure of an institutional control, a Corrective Measures Work Plan will be submitted to the NYSDEC for approval. This plan will explain the failure and provide the details and schedule for performing work necessary to correct the failure. Unless an emergency condition exists, no work will be performed pursuant to the Corrective Measures Work Plan until it has been approved by the NYSDEC. Upon completion of the Corrective Measure, a signed certification form must be submitted to the Department.

## 7.0 REFERENCES

- 6NYCRR Part 375, Environmental Remediation Programs. December 14, 2006.
- NYSDEC DER-10 – “Technical Guidance for Site Investigation and Remediation”.
- NYSDEC, 1998. Ambient Water Quality Standards and Guidance Values and Groundwater Effluent Limitations Division of Water Technical and Operational Guidance Series (TOGS) 1.1.1. June 1998 (April 2000 addendum).
- Work Plan for the Remedial Investigation of NYSDEC Spill Case #0812579. March 17, 2009.
- Remedial Investigation Report prepared by Louis Berger & Associates. May 15, 2009.
- Remedial Action Plan prepared by Louis Berger & Associates. May 21, 2010.
- Phase I Environmental Site Assessment prepared by Arcadis, Inc. June 3, 2016.
- Groundwater Monitoring and Remediation Report for the Fourth Quarter 2016 prepared by URS. January 25, 2017.
- Phase I Environmental Site Assessment prepared by Roux. July 11, 2017.
- Phase II Environmental Site Assessment prepared by Roux. August 10, 2017.
- Remedial Investigation Work Plan prepared by Roux. January 15, 2018.
- Remedial Investigation Report prepared by Roux. October 22, 2018.
- Remedial Action Work Plan prepared by Roux. December 14, 2018.

**TABLES**

1. Notifications (Embedded in Text)
2. Groundwater Elevation Measurements
3. Summary of Remaining Semivolatile Organic Compound Exceedances in Soil
4. Summary of Remaining Metal Exceedances in Soil
5. Summary of Remaining Pesticide and Herbicide Exceedances in Soil
6. Schedule of Inspection Reports (Embedded in Text)



**Table 2. Groundwater Elevation Measurements - 1221 Spofford Avenue, Bronx, New York**

Well	Date	Measuring Point Elevation (ft NAVD88)	Depth To Water (ft bls)	Groundwater Elevation (ft NAVD88)
MW-1	6/22/2018	50.31	12.43	37.88
MW-2	6/22/2018	50.10	13.55	36.55
MW-3	6/22/2018	50.23	16.60	33.70
MW-4	6/22/2018	50.08	18.22	31.87
MW-5	6/22/2018	29.08	1.51	27.67
MW-6	6/22/2018	29.18	1.12	28.06
RXMW-1	6/22/2018	34.91	9.41	25.50
RXMW-2	6/22/2018	32.09	8.35	23.74
RXMW-3	6/22/2018	29.48	1.30	28.18
RXMW-4	6/22/2018	50.48	21.39	29.09
RXMW-5	6/22/2018	50.37	13.33	37.04
RXMW-6	6/22/2018	50.52	4.00	46.52
RXMW-7	6/22/2018	50.71	2.90	47.81
RXMW-8	6/22/2018	44.01	13.24	30.77
RXMW-9	6/22/2018	58.21	8.46	49.75
RXMW-10	6/22/2018	58.48	4.98	53.50
RXMW-11	6/22/2018	34.33	5.00	29.33

ft - Feet

ft bls - Feet below land surface

ft NAVD88 - Feet relative to North American Vertical Datum of 1988

Monitoring wells included in this table were installed during the Roux 2018 Remedial Investigation.

Monitoring wells included in this table were decommissioned and removed as part of the onsite remediation and construction activities.

### Notes Utilized Throughout Tables

#### Soil Tables

J - Estimated value

U - Indicates that the compound was analyzed for but not detected

B - The analyte was found in an associated blank as well as in the sample

P - The RPD between the results for the two columns exceeds the method-specified criteria

RPD - Relative Percent Difference

T - Indicates that a quality control parameter has exceeded laboratory limits

FD - Duplicate sample

NA - Compound was not analyzed for by laboratory

mg/kg - Milligrams per kilogram

NYSDEC - New York State Department of Environmental Conservation

SCO - Soil Cleanup Objectives

-- No SCO available

**Bold data indicates that parameter was detected above the NYSDEC Part 375 Unrestricted Use SCO**

**Shaded data indicates that parameter was detected above the NYSDEC Part 375 Restricted Residential SCO**

**Red data indicates that parameter was detected above the NYSDEC Part 375 Protection of Groundwater SCO**

**Table 3. Summary of Remaining Semivolatile Organic Compound Exceedances in Soil - 1221 Spofford Avenue, Bronx, New York**

					Sample Designation:	1A-EP-B-1	1A-EP-SW-4	1B-EP-SW-1	1B-EP-SW-2
					Sample Date:	06/25/2019	09/30/2019	09/30/2019	09/30/2019
					Sample Depth (ft bls):	9 - 11	0 - 1	0 - 1	0 - 1
					Normal or Field Duplicate:	N	N	N	N
Parameter	NYSDEC Part 375 Unrestricted Use SCO	NYSDEC Part 375 Restricted Residential SCO	NYSDEC Part 375 Protection of Groundwater SCO	Unit					
1,2,4,5-Tetrachlorobenzene	--	--	--	MG/KG	0.38 U	0.37 U	0.39 U	0.42 U	
1,4-Dioxane (P-Dioxane)	0.1	13	0.1	MG/KG	NA	0.11 U	0.12 U	0.13 U	
2,3,4,6-Tetrachlorophenol	--	--	--	MG/KG	0.38 U	0.37 U	0.39 U	0.42 U	
2,4,5-Trichlorophenol	--	--	--	MG/KG	0.38 U	0.37 U	0.39 U	0.42 U	
2,4,6-Trichlorophenol	--	--	--	MG/KG	0.15 U	0.15 U	0.16 U	0.17 U	
2,4-Dichlorophenol	--	--	--	MG/KG	0.15 U	0.15 U	0.16 U	0.17 U	
2,4-Dimethylphenol	--	--	--	MG/KG	0.38 U	0.37 U	0.39 U	0.42 U	
2,4-Dinitrophenol	--	--	--	MG/KG	0.31 U	0.3 U	0.31 U	0.34 U	
2,4-Dinitrotoluene	--	--	--	MG/KG	0.078 U	0.075 U	0.079 U	0.085 U	
2,6-Dinitrotoluene	--	--	--	MG/KG	0.078 U	0.075 U	0.079 U	0.085 U	
2-Chloronaphthalene	--	--	--	MG/KG	0.38 U	0.37 U	0.39 U	0.42 U	
2-Chlorophenol	--	--	--	MG/KG	0.38 U	0.37 U	0.39 U	0.42 U	
2-Methylnaphthalene	--	--	--	MG/KG	0.045 J	0.07 J	0.058 J	0.09 J	
2-Methylphenol (O-Cresol)	0.33	100	0.33	MG/KG	0.38 U	0.37 U	0.39 U	0.42 U	
2-Nitroaniline	--	--	--	MG/KG	0.38 U	0.37 U	0.39 U	0.42 U	
2-Nitrophenol	--	--	--	MG/KG	0.38 U	0.37 U	0.39 U	0.42 U	
3,3'-Dichlorobenzidine	--	--	--	MG/KG	0.15 UT	0.15 U	0.16 U	0.17 U	
3-Nitroaniline	--	--	--	MG/KG	0.38 U	0.37 U	0.39 U	0.42 U	
4,6-Dinitro-2-Methylphenol	--	--	--	MG/KG	0.31 U	0.3 U	0.31 U	0.34 U	
4-Bromophenyl Phenyl Ether	--	--	--	MG/KG	0.38 U	0.37 U	0.39 U	0.42 U	
4-Chloro-3-Methylphenol	--	--	--	MG/KG	0.38 U	0.37 U	0.39 U	0.42 U	
4-Chloroaniline	--	--	--	MG/KG	0.38 U	0.37 U	0.39 U	0.42 U	
4-Chlorophenyl Phenyl Ether	--	--	--	MG/KG	0.38 U	0.37 U	0.39 U	0.42 U	
4-Methylphenol (P-Cresol)	0.33	100	0.33	MG/KG	0.38 U	0.37 U	0.39 U	0.42 U	
4-Nitroaniline	--	--	--	MG/KG	0.38 U	0.37 U	0.39 U	0.42 U	
4-Nitrophenol	--	--	--	MG/KG	0.78 U	0.75 U	0.79 U	0.85 U	
Acenaphthene	20	100	98	MG/KG	0.12 J	0.35 J	0.25 J	0.53	
Acenaphthylene	100	100	107	MG/KG	0.29 J	0.37 U	0.39 U	0.42 U	
Acetophenone	--	--	--	MG/KG	0.38 U	0.37 U	0.39 U	0.42 U	
Anthracene	100	100	1000	MG/KG	0.4	0.47	0.52	0.67	
Atrazine	--	--	--	MG/KG	0.15 U	0.15 U	0.16 U	0.17 U	

**Table 3. Summary of Remaining Semivolatile Organic Compound Exceedances in Soil - 1221 Spofford Avenue, Bronx, New York**

					Sample Designation:	1A-EP-B-1	1A-EP-SW-4	1B-EP-SW-1	1B-EP-SW-2
					Sample Date:	06/25/2019	09/30/2019	09/30/2019	09/30/2019
					Sample Depth (ft bls):	9 - 11	0 - 1	0 - 1	0 - 1
					Normal or Field Duplicate:	N	N	N	N
Parameter	NYSDEC Part 375 Unrestricted Use SCO	NYSDEC Part 375 Restricted Residential SCO	NYSDEC Part 375 Protection of Groundwater SCO	Unit					
Benzaldehyde	--	--	--	MG/KG	0.38 U	0.37 U	0.39 U	0.42 U	
Benzo(A)Anthracene	1	1	1	MG/KG	0.27	1	1.2	1.2	
Benzo(A)Pyrene	1	1	22	MG/KG	0.29	0.83	0.93	0.99	
Benzo(B)Fluoranthene	1	1	1.7	MG/KG	0.37	1.1	1.3	1.3	
Benzo(G,H,I)Perylene	100	100	1000	MG/KG	1.5	0.5	0.54	0.56	
Benzo(K)Fluoranthene	0.8	3.9	1.7	MG/KG	0.12	0.47	0.46	0.52	
Benzyl Butyl Phthalate	--	--	--	MG/KG	0.082 J	0.032 J	0.045 J	0.046 J	
Biphenyl (Diphenyl)	--	--	--	MG/KG	0.38 U	0.37 U	0.39 U	0.42 U	
Bis(2-Chloroethoxy) Methane	--	--	--	MG/KG	0.38 U	0.37 U	0.39 U	0.42 U	
Bis(2-Chloroethyl) Ether (2-Chloroethyl Ether)	--	--	--	MG/KG	0.038 U	0.037 U	0.039 U	0.042 U	
Bis(2-Chloroisopropyl) Ether	--	--	--	MG/KG	0.38 U	0.37 U	0.39 U	0.42 U	
Bis(2-Ethylhexyl) Phthalate	--	--	--	MG/KG	0.38 U	0.37 U	0.077 J	0.048 J	
Caprolactam	--	--	--	MG/KG	0.38 U	0.37 U	0.39 U	0.42 U	
Carbazole	--	--	--	MG/KG	0.084 J	0.27 J	0.21 J	0.36 J	
Chrysene	1	3.9	1	MG/KG	0.26 J	1	1.2	1.3	
Dibenz(A,H)Anthracene	0.33	0.33	1000	MG/KG	0.2	0.15	0.18	0.18	
Dibenzofuran	7	59	210	MG/KG	0.06 J	0.18 J	0.15 J	0.26 J	
Diethyl Phthalate	--	--	--	MG/KG	0.38 U	0.37 U	0.39 U	0.42 U	
Dimethyl Phthalate	--	--	--	MG/KG	0.38 U	0.37 U	0.39 U	0.42 U	
Di-N-Butyl Phthalate	--	--	--	MG/KG	0.38 U	0.37 U	0.39 U	0.42 U	
Di-N-Octylphthalate	--	--	--	MG/KG	0.38 U	0.37 U	0.39 U	0.42 U	
Fluoranthene	100	100	1000	MG/KG	0.52	2	2.4	2.6	
Fluorene	30	100	386	MG/KG	0.1 J	0.29 J	0.26 J	0.4 J	
Hexachlorobenzene	0.33	1.2	3.2	MG/KG	0.038 U	0.037 U	0.039 U	0.042 U	
Hexachlorobutadiene	--	--	--	MG/KG	0.078 U	0.075 U	0.079 U	0.085 U	
Hexachlorocyclopentadiene	--	--	--	MG/KG	0.38 U	0.37 U	0.39 U	0.42 U	
Hexachloroethane	--	--	--	MG/KG	0.038 U	0.037 U	0.039 U	0.042 U	
Indeno(1,2,3-C,D)Pyrene	0.5	0.5	8.2	MG/KG	1.1	0.56	0.66	0.64	
Isophorone	--	--	--	MG/KG	0.15 U	0.15 U	0.16 U	0.17 U	
Naphthalene	12	100	12	MG/KG	0.12 J	0.19 J	0.11 J	0.29 J	
Nitrobenzene	--	--	--	MG/KG	0.038 U	0.037 U	0.039 U	0.042 U	

**Table 3. Summary of Remaining Semivolatile Organic Compound Exceedances in Soil - 1221 Spofford Avenue, Bronx, New York**

					Sample Designation:	1A-EP-B-1	1A-EP-SW-4	1B-EP-SW-1	1B-EP-SW-2
					Sample Date:	06/25/2019	09/30/2019	09/30/2019	09/30/2019
					Sample Depth (ft bls):	9 - 11	0 - 1	0 - 1	0 - 1
					Normal or Field Duplicate:	N	N	N	N
Parameter	NYSDEC Part 375 Unrestricted Use SCO	NYSDEC Part 375 Restricted Residential SCO	NYSDEC Part 375 Protection of Groundwater SCO	Unit					
N-Nitrosodi-N-Propylamine	--	--	--	MG/KG	0.038 U	0.037 U	0.039 U	0.042 U	
N-Nitrosodiphenylamine	--	--	--	MG/KG	0.38 U	0.37 U	0.39 U	0.42 U	
Pentachlorophenol	0.8	6.7	0.8	MG/KG	0.31 U	0.3 U	0.31 U	0.34 U	
Phenanthrene	100	100	1000	MG/KG	0.54	2	2.3	2.8	
Phenol	0.33	100	0.33	MG/KG	0.38 U	0.37 U	0.39 U	0.42 U	
Pyrene	100	100	1000	MG/KG	0.44	2.1	2.5	2.8	

**Table 3. Summary of Remaining Semivolatile Organic Compound Exceedances in Soil - 1221 Spofford Avenue, Bronx, New York**

					Sample Designation:	1B-EP-SW-8	2A-EP-SW-3	2B-EP-B-2	IA-EP-SW-1
					Sample Date:	01/03/2020	04/21/2020	05/15/2020	11/05/2019
					Sample Depth (ft bls):	0 - 1	0 - 1	0 - 1	0 - 1
					Normal or Field Duplicate:	N	N	N	N
Parameter	NYSDEC Part 375 Unrestricted Use SCO	NYSDEC Part 375 Restricted Residential SCO	NYSDEC Part 375 Protection of Groundwater SCO	Unit					
1,2,4,5-Tetrachlorobenzene	--	--	--	MG/KG	0.38 U	0.36 U	0.35 U	0.38 U	
1,4-Dioxane (P-Dioxane)	0.1	13	0.1	MG/KG	0.12 U	0.11 U	0.11 U	0.12 U	
2,3,4,6-Tetrachlorophenol	--	--	--	MG/KG	0.38 U	0.36 U	0.35 U	0.38 U	
2,4,5-Trichlorophenol	--	--	--	MG/KG	0.38 U	0.36 U	0.35 U	0.38 U	
2,4,6-Trichlorophenol	--	--	--	MG/KG	0.15 U	0.14 U	0.14 U	0.15 U	
2,4-Dichlorophenol	--	--	--	MG/KG	0.15 UT	0.14 U	0.14 U	0.15 U	
2,4-Dimethylphenol	--	--	--	MG/KG	0.38 U	0.36 U	0.35 U	0.38 U	
2,4-Dinitrophenol	--	--	--	MG/KG	0.31 U	0.29 U	0.28 U	0.31 U	
2,4-Dinitrotoluene	--	--	--	MG/KG	0.077 U	0.073 U	0.072 U	0.078 U	
2,6-Dinitrotoluene	--	--	--	MG/KG	0.077 UT	0.073 U	0.072 U	0.078 U	
2-Chloronaphthalene	--	--	--	MG/KG	0.38 U	0.36 U	0.35 U	0.38 U	
2-Chlorophenol	--	--	--	MG/KG	0.38 U	0.36 U	0.35 U	0.38 U	
2-Methylnaphthalene	--	--	--	MG/KG	0.042 J	0.11 J	0.12 J	0.077 J	
2-Methylphenol (O-Cresol)	0.33	100	0.33	MG/KG	0.38 U	0.36 U	0.35 U	0.38 U	
2-Nitroaniline	--	--	--	MG/KG	0.38 U	0.36 U	0.35 U	0.38 U	
2-Nitrophenol	--	--	--	MG/KG	0.38 U	0.36 U	0.35 U	0.38 U	
3,3'-Dichlorobenzidine	--	--	--	MG/KG	0.15 U	0.14 U	0.14 U	0.15 U	
3-Nitroaniline	--	--	--	MG/KG	0.38 U	0.36 U	0.35 U	0.38 U	
4,6-Dinitro-2-Methylphenol	--	--	--	MG/KG	0.31 U	0.29 U	0.28 U	0.31 U	
4-Bromophenyl Phenyl Ether	--	--	--	MG/KG	0.38 U	0.36 U	0.35 U	0.38 U	
4-Chloro-3-Methylphenol	--	--	--	MG/KG	0.38 U	0.36 U	0.35 U	0.38 U	
4-Chloroaniline	--	--	--	MG/KG	0.38 U	0.36 U	0.35 U	0.38 U	
4-Chlorophenyl Phenyl Ether	--	--	--	MG/KG	0.38 U	0.36 U	0.35 U	0.38 U	
4-Methylphenol (P-Cresol)	0.33	100	0.33	MG/KG	0.38 U	0.36 U	0.35 U	0.38 U	
4-Nitroaniline	--	--	--	MG/KG	0.38 U	0.36 U	0.35 U	0.38 U	
4-Nitrophenol	--	--	--	MG/KG	0.77 U	0.73 U	0.72 U	0.78 U	
Acenaphthene	20	100	98	MG/KG	0.24 J	0.14 J	0.54	0.38	
Acenaphthylene	100	100	107	MG/KG	0.38 U	0.047 J	0.35 U	0.014 J	
Acetophenone	--	--	--	MG/KG	0.38 U	0.36 U	0.35 U	0.38 U	
Anthracene	100	100	1000	MG/KG	0.38	0.32 J	0.77	0.49	
Atrazine	--	--	--	MG/KG	0.15 U	0.14 U	0.14 U	0.15 U	

**Table 3. Summary of Remaining Semivolatile Organic Compound Exceedances in Soil - 1221 Spofford Avenue, Bronx, New York**

					Sample Designation:	1B-EP-SW-8	2A-EP-SW-3	2B-EP-B-2	IA-EP-SW-1
					Sample Date:	01/03/2020	04/21/2020	05/15/2020	11/05/2019
					Sample Depth (ft bls):	0 - 1	0 - 1	0 - 1	0 - 1
					Normal or Field Duplicate:	N	N	N	N
Parameter	NYSDEC Part 375 Unrestricted Use SCO	NYSDEC Part 375 Restricted Residential SCO	NYSDEC Part 375 Protection of Groundwater SCO	Unit					
Benzaldehyde	--	--	--	MG/KG	0.38 U	0.36 UT	0.35 U	0.38 U	
Benzo(A)Anthracene	1	1	1	MG/KG	0.91	0.92	1.4	1.1	
Benzo(A)Pyrene	1	1	22	MG/KG	0.72	0.91	1.2	0.84	
Benzo(B)Fluoranthene	1	1	1.7	MG/KG	1.1	1.1	1.8	1.2	
Benzo(G,H,I)Perylene	100	100	1000	MG/KG	0.34 J	0.49	0.41	0.42	
Benzo(K)Fluoranthene	0.8	3.9	1.7	MG/KG	0.4	0.46	0.64	0.5	
Benzyl Butyl Phthalate	--	--	--	MG/KG	0.057 J	0.36 U	0.021 J	0.27 J	
Biphenyl (Diphenyl)	--	--	--	MG/KG	0.38 U	0.024 J	0.039 J	0.03 J	
Bis(2-Chloroethoxy) Methane	--	--	--	MG/KG	0.38 U	0.36 U	0.35 U	0.38 U	
Bis(2-Chloroethyl) Ether (2-Chloroethyl Ether)	--	--	--	MG/KG	0.038 U	0.036 U	0.035 U	0.038 U	
Bis(2-Chloroisopropyl) Ether	--	--	--	MG/KG	0.38 U	0.36 U	0.35 U	0.38 U	
Bis(2-Ethylhexyl) Phthalate	--	--	--	MG/KG	0.052 J	0.36 U	0.023 J	0.067 J	
Caprolactam	--	--	--	MG/KG	0.38 U	0.36 U	0.35 U	0.38 U	
Carbazole	--	--	--	MG/KG	0.25 J	0.18 J	0.45	0.33 J	
Chrysene	1	3.9	1	MG/KG	0.95	0.96	1.3	1.1 T	
Dibenz(A,H)Anthracene	0.33	0.33	1000	MG/KG	0.11	0.15	0.14	0.12	
Dibenzofuran	7	59	210	MG/KG	0.14 J	0.12 J	0.3 J	0.2 J	
Diethyl Phthalate	--	--	--	MG/KG	0.38 U	0.36 U	0.35 U	0.38 U	
Dimethyl Phthalate	--	--	--	MG/KG	0.38 U	0.36 U	0.35 U	0.38 U	
Di-N-Butyl Phthalate	--	--	--	MG/KG	0.38 U	0.36 U	0.35 U	0.38 U	
Di-N-Octylphthalate	--	--	--	MG/KG	0.38 U	0.36 U	0.35 U	0.38 U	
Fluoranthene	100	100	1000	MG/KG	1.9	2.4	3.5	2.5	
Fluorene	30	100	386	MG/KG	0.2 J	0.1 J	0.38	0.26 J	
Hexachlorobenzene	0.33	1.2	3.2	MG/KG	0.038 U	0.036 U	0.035 U	0.038 U	
Hexachlorobutadiene	--	--	--	MG/KG	0.077 U	0.073 U	0.072 U	0.078 U	
Hexachlorocyclopentadiene	--	--	--	MG/KG	0.38 U	0.36 U	0.35 U	0.38 U	
Hexachloroethane	--	--	--	MG/KG	0.038 U	0.036 U	0.035 U	0.038 U	
Indeno(1,2,3-C,D)Pyrene	0.5	0.5	8.2	MG/KG	0.39	0.58	0.5	0.49	
Isophorone	--	--	--	MG/KG	0.15 U	0.14 U	0.14 U	0.15 U	
Naphthalene	12	100	12	MG/KG	0.094 J	0.15 J	0.34 J	0.2 J	
Nitrobenzene	--	--	--	MG/KG	0.038 U	0.036 U	0.035 U	0.038 U	

**Table 3. Summary of Remaining Semivolatile Organic Compound Exceedances in Soil - 1221 Spofford Avenue, Bronx, New York**

					Sample Designation:	1B-EP-SW-8	2A-EP-SW-3	2B-EP-B-2	1A-EP-SW-1
					Sample Date:	01/03/2020	04/21/2020	05/15/2020	11/05/2019
					Sample Depth (ft bls):	0 - 1	0 - 1	0 - 1	0 - 1
					Normal or Field Duplicate:	N	N	N	N
Parameter	NYSDEC Part 375 Unrestricted Use SCO	NYSDEC Part 375 Restricted Residential SCO	NYSDEC Part 375 Protection of Groundwater SCO	Unit					
N-Nitrosodi-N-Propylamine	--	--	--	MG/KG	0.038 U	0.036 U	0.035 U	0.038 U	
N-Nitrosodiphenylamine	--	--	--	MG/KG	0.38 U	0.36 U	0.016 J	0.38 U	
Pentachlorophenol	0.8	6.7	0.8	MG/KG	0.31 U	0.29 U	0.28 U	0.31 U	
Phenanthrene	100	100	1000	MG/KG	1.7	2.2	3.3	2.2	
Phenol	0.33	100	0.33	MG/KG	0.38 U	0.36 U	0.35 U	0.38 U	
Pyrene	100	100	1000	MG/KG	1.6	2.1	2.6	2	



**Table 4. Summary of Remaining Metal Exceedances in Soil - 1221 Spofford Avenue, Bronx, New York**

					Sample Designation:	1A-EP-B-1	1A-EP-B-10	1A-EP-B-11	1A-EP-B-12	1A-EP-B-13
					Sample Date:	06/25/2019	06/26/2019	06/26/2019	10/24/2019	11/27/2019
					Sample Depth (ft bls):	9 - 11	7 - 9	7 - 9	0 - 1	0 - 1
					Normal or Field Duplicate:	N	N	N	N	N
Parameter	NYSDEC Part 375 Unrestricted Use SCO	NYSDEC Part 375 Restricted Residential SCO	NYSDEC Part 375 Protection of Groundwater SCO	Unit						
Aluminum	--	--	--	MG/KG	15600	14700	17100	13800	18900	
Antimony	--	--	--	MG/KG	1.1 U	1.2 U	1.1 U	1.1 U	0.83 U	
Arsenic	13	16	16	MG/KG	1.9	2	0.47 J	1.5	0.38 J	
Barium	350	400	820	MG/KG	180	171	157	114	138	
Beryllium	7.2	72	47	MG/KG	1.2	0.66	0.47	0.44	0.95	
Cadmium	2.5	4.3	7.5	MG/KG	1.1 U	0.41 J	1.1 U	1.1 U	0.83 U	
Calcium	--	--	--	MG/KG	14600	6130	2480	4860	2480	
Chromium III	30	180	--	MG/KG	<b>46.4</b>	<b>40</b>	<b>50.2</b>	<b>30.4</b>	<b>42.7</b>	
Chromium, Hexavalent	1	110	19	MG/KG	2.3 U	2.4 U	2.2 U	2.3 U	2.2 U	
Chromium, Total	30	180	--	MG/KG	<b>46.4</b>	<b>40</b>	<b>50.2</b>	<b>30.4</b>	<b>42.7</b>	
Cobalt	--	--	--	MG/KG	15.6	15.5	15.8	12.1	17.6	
Copper	50	270	1720	MG/KG	37.4	<b>89.6</b>	33.2	<b>57.6</b>	<b>55</b>	
Cyanide	27	27	40	MG/KG	NA	NA	NA	NA	NA	
Iron	--	--	--	MG/KG	25500	31400	30700	25000	31500	
Lead	63	400	450	MG/KG	27.3	<b>85.3</b>	6.2	18.1	7.5	
Magnesium	--	--	--	MG/KG	10100	8050	8520	5640	10200	
Manganese	1600	2000	2000	MG/KG	328	396	234	362	181	
Mercury	0.18	0.81	0.73	MG/KG	0.014 J	0.035	0.017 U	0.021	0.017 U	
Nickel	30	310	130	MG/KG	<b>47.7</b>	<b>36.2</b>	<b>38.2</b>	25.2	<b>43</b>	
Potassium	--	--	--	MG/KG	8530	5230	8400	4710	12400	
Selenium	3.9	180	4	MG/KG	5.5 U	0.34 J	5.5 U	5.4 U	0.84 J	
Silver	2	180	8.3	MG/KG	1.1 U	1.2 U	1.1 U	1.1 U	0.83 U	
Sodium	--	--	--	MG/KG	251	180	187	181	232	
Thallium	--	--	--	MG/KG	0.52	0.43 J	0.49	0.31 J	0.76	
Vanadium	--	--	--	MG/KG	55	49.7	51.7	38.2	69.5	
Zinc	109	10000	2480	MG/KG	95.5	<b>332</b>	84.6	<b>117</b>	90.7	

**Table 4. Summary of Remaining Metal Exceedances in Soil - 1221 Spofford Avenue, Bronx, New York**

					Sample Designation:	1A-EP-B-16	1A-EP-B-18	1A-EP-B-2	1A-EP-B-20	1A-EP-B-3
					Sample Date:	01/15/2020	12/05/2019	06/25/2019	12/16/2019	06/25/2019
					Sample Depth (ft bls):	0 - 1	0 - 1	8 - 10	0 - 1	6 - 8
					Normal or Field Duplicate:	N	N	N	N	N
Parameter	NYSDEC Part 375 Unrestricted Use SCO	NYSDEC Part 375 Restricted Residential SCO	NYSDEC Part 375 Protection of Groundwater SCO	Unit						
Aluminum	--	--	--	MG/KG	14700	17800	26200	18100	18900	
Antimony	--	--	--	MG/KG	0.89 U	0.9 U	1.1 U	1.1 U	1.1 U	
Arsenic	13	16	16	MG/KG	0.9	0.6 J	0.37 J	1.1	0.47 J	
Barium	350	400	820	MG/KG	140	175	240	186	138	
Beryllium	7.2	72	47	MG/KG	0.82	0.55	1.2	0.79	1	
Cadmium	2.5	4.3	7.5	MG/KG	0.89 U	0.9 U	1.1 U	1.1 U	1.1 U	
Calcium	--	--	--	MG/KG	3890	5970	2650	11500	5220	
Chromium III	30	180	--	MG/KG	<b>32.6</b>	<b>40.2</b>	<b>51.2</b>	<b>50.9</b>	<b>63.5</b>	
Chromium, Hexavalent	1	110	19	MG/KG	2.3 U	2.3 U	2.3 U	2.3 U	2.3 U	
Chromium, Total	30	180	--	MG/KG	<b>32.6</b>	<b>40.2</b>	<b>51.2</b>	<b>50.9</b>	<b>63.5</b>	
Cobalt	--	--	--	MG/KG	22.7	14.3	19.8	16	11	
Copper	50	270	1720	MG/KG	<b>52</b>	<b>58</b>	<b>73.5</b>	46.9	21.6	
Cyanide	27	27	40	MG/KG	NA	NA	NA	NA	NA	
Iron	--	--	--	MG/KG	26400	32800	44900	30900	27300	
Lead	63	400	450	MG/KG	17	11.8	5.3	21.8	15.3	
Magnesium	--	--	--	MG/KG	7640	12100	12100	11000	12500	
Manganese	1600	2000	2000	MG/KG	320	363	354	272	297	
Mercury	0.18	0.81	0.73	MG/KG	0.018 U	0.018 U	0.015 J	0.024	0.019 U	
Nickel	30	310	130	MG/KG	<b>42.6</b>	<b>32.9</b>	<b>39.3</b>	<b>46</b>	<b>30.6</b>	
Potassium	--	--	--	MG/KG	8060	9760	18300	10300	13000	
Selenium	3.9	180	4	MG/KG	0.42 J	0.33 J	5.5 U	5.4 U	5.6 U	
Silver	2	180	8.3	MG/KG	0.89 U	0.9 U	1.1 U	1.1 U	1.1 U	
Sodium	--	--	--	MG/KG	173	255	338	210	98.6 J	
Thallium	--	--	--	MG/KG	0.67	0.6	0.8	0.55	0.67	
Vanadium	--	--	--	MG/KG	44.9	70.5	71.1	51.8	59.7	
Zinc	109	10000	2480	MG/KG	101	91.1	108	<b>115</b>	96.5	

**Table 4. Summary of Remaining Metal Exceedances in Soil - 1221 Spofford Avenue, Bronx, New York**

					Sample Designation:	1A-EP-B-4	1A-EP-B-4	1A-EP-B-6	1A-EP-SW-11	1A-EP-SW-11
					Sample Date:	06/26/2019	06/26/2019	06/26/2019	12/05/2019	12/05/2019
					Sample Depth (ft bls):	6 - 8	6 - 8	16 - 18	0 - 1	0 - 1
					Normal or Field Duplicate:	N	FD	N	N	FD
Parameter	NYSDEC Part 375 Unrestricted Use SCO	NYSDEC Part 375 Restricted Residential SCO	NYSDEC Part 375 Protection of Groundwater SCO	Unit						
Aluminum	--	--	--	MG/KG	19900	15300	14800	13100	13600	
Antimony	--	--	--	MG/KG	1 U	1.1 U	1.1 U	0.58 J	0.29 J	
Arsenic	13	16	16	MG/KG	1 U	1.1 U	1.1 U	2.2	2.2	
Barium	350	400	820	MG/KG	267	224	122	146	157	
Beryllium	7.2	72	47	MG/KG	0.73	0.96	0.56	0.96	0.8	
Cadmium	2.5	4.3	7.5	MG/KG	1 U	1.1 U	1.1 U	0.84 U	0.87 U	
Calcium	--	--	--	MG/KG	2020	2470	4360	11600	10900	
Chromium III	30	180	--	MG/KG	<b>43.4</b>	28.2	<b>33.3</b>	<b>38.6</b>	<b>36.7</b>	
Chromium, Hexavalent	1	110	19	MG/KG	2.2 U	2.2 U	2.2 U	2.3 U	2.3 U	
Chromium, Total	30	180	--	MG/KG	<b>43.4</b>	28.2	<b>33.3</b>	<b>38.6</b>	<b>36.7</b>	
Cobalt	--	--	--	MG/KG	18.4	16.6	18.2	16.5	16.3	
Copper	50	270	1720	MG/KG	35	<b>53.7</b>	28.7	<b>141</b>	<b>114</b>	
Cyanide	27	27	40	MG/KG	NA	NA	NA	NA	NA	
Iron	--	--	--	MG/KG	32300	23900	22900	27700	27700	
Lead	63	400	450	MG/KG	8	20.3	6	<b>139</b>	<b>105</b>	
Magnesium	--	--	--	MG/KG	9180	7140	10200	8170	7510	
Manganese	1600	2000	2000	MG/KG	177	109	199	405	385	
Mercury	0.18	0.81	0.73	MG/KG	0.019 U	0.018 U	0.017 U	0.035	0.029	
Nickel	30	310	130	MG/KG	<b>33.6</b>	23.7	<b>38.3</b>	<b>37.9</b>	<b>34.2</b>	
Potassium	--	--	--	MG/KG	12800	9990	10700	4370	4570	
Selenium	3.9	180	4	MG/KG	5.1 U	5.5 U	5.6 U	4.2 U	4.3 U	
Silver	2	180	8.3	MG/KG	1 U	1.1 U	1.1 U	0.84 U	0.87 U	
Sodium	--	--	--	MG/KG	194	128	185	277	296	
Thallium	--	--	--	MG/KG	0.55	0.41 J	0.66	0.32 J	0.34 J	
Vanadium	--	--	--	MG/KG	59.9	45.1	41.8	38.1	41.1	
Zinc	109	10000	2480	MG/KG	<b>113</b>	91.8	<b>111</b>	<b>956</b>	<b>662</b>	

**Table 4. Summary of Remaining Metal Exceedances in Soil - 1221 Spofford Avenue, Bronx, New York**

					Sample Designation:	1A-EP-SW-12	1A-EP-SW-2	1A-EP-SW-3	1A-EP-SW-4	1A-EP-SW-5
					Sample Date:	11/25/2019	12/16/2019	12/30/2019	09/30/2019	09/30/2019
					Sample Depth (ft bls):	0 - 1	0 - 1	0 - 1	0 - 1	0 - 1
					Normal or Field Duplicate:	N	N	N	N	N
Parameter	NYSDEC Part 375 Unrestricted Use SCO	NYSDEC Part 375 Restricted Residential SCO	NYSDEC Part 375 Protection of Groundwater SCO	Unit						
Aluminum	--	--	--	MG/KG	9880	16000	13300	15200	2360	
Antimony	--	--	--	MG/KG	1.1 U	1.1 U	1.2 U	1.1 U	1 U	
Arsenic	13	16	16	MG/KG	1.5	1.1	1.9	1.9	5.5	
Barium	350	400	820	MG/KG	117	175	170	288	37.4	
Beryllium	7.2	72	47	MG/KG	0.71	0.72	0.67	1.2	0.58	
Cadmium	2.5	4.3	7.5	MG/KG	1.1 U	1.1 U	1.2 U	1.1 U	1 U	
Calcium	--	--	--	MG/KG	30900	12200	7300	16000	157000	
Chromium III	30	180	--	MG/KG	25.4	<b>46</b>	<b>40.6</b>	<b>45.2</b>	14	
Chromium, Hexavalent	1	110	19	MG/KG	2.3 U	0.4 J	2.4 U	2.3 U	2.1 U	
Chromium, Total	30	180	--	MG/KG	25.4	<b>46.4</b>	<b>40.6</b>	<b>45.2</b>	14	
Cobalt	--	--	--	MG/KG	11	15.2	14	32.1	6.7	
Copper	50	270	1720	MG/KG	38.9	42.8	41.8	<b>304</b>	<b>90.1</b>	
Cyanide	27	27	40	MG/KG	NA	NA	NA	NA	NA	
Iron	--	--	--	MG/KG	21600	27200	25600	39100	14300	
Lead	63	400	450	MG/KG	33.3	28.2	36	<b>189</b>	<b>103</b>	
Magnesium	--	--	--	MG/KG	18400	9790	8440	9990	82600	
Manganese	1600	2000	2000	MG/KG	367	285	288	470	198	
Mercury	0.18	0.81	0.73	MG/KG	0.017	0.017 J	0.021	0.031	0.015 J	
Nickel	30	310	130	MG/KG	21.6	<b>44.7</b>	<b>36.4</b>	<b>49.7</b>	15.4	
Potassium	--	--	--	MG/KG	4210	8930	6150	7940	781	
Selenium	3.9	180	4	MG/KG	5.4 U	5.6 U	5.9 U	0.35 J	5.1 U	
Silver	2	180	8.3	MG/KG	1.1 U	1.1 U	1.2 U	1.1 U	1 U	
Sodium	--	--	--	MG/KG	175	193	126	249	273	
Thallium	--	--	--	MG/KG	0.29 J	0.51	0.42 J	0.52	0.13 J	
Vanadium	--	--	--	MG/KG	34.9	46	43.9	50.1	15.6	
Zinc	109	10000	2480	MG/KG	<b>162</b>	<b>142</b>	<b>264</b>	<b>1230</b>	<b>561</b>	

**Table 4. Summary of Remaining Metal Exceedances in Soil - 1221 Spofford Avenue, Bronx, New York**

					Sample Designation:	1A-EP-SW-6	1A-EP-SW-7	1A-EP-SW-9	1B-E1-B-13	1B-E1-B-17
					Sample Date:	09/30/2019	11/20/2019	01/15/2020	09/30/2019	09/30/2019
					Sample Depth (ft bls):	0 - 1	0 - 1	0 - 1	0 - 1	0 - 1
					Normal or Field Duplicate:	N	N	N	N	N
Parameter	NYSDEC Part 375 Unrestricted Use SCO	NYSDEC Part 375 Restricted Residential SCO	NYSDEC Part 375 Protection of Groundwater SCO	Unit						
Aluminum	--	--	--	MG/KG	11300	16300	15200	13700	28800	
Antimony	--	--	--	MG/KG	1.2 U	1.3 U	0.87 U	1 U	1.1 U	
Arsenic	13	16	16	MG/KG	2.3	3.5	0.87	0.78 J	0.77 J	
Barium	350	400	820	MG/KG	141	109	147	168	326	
Beryllium	7.2	72	47	MG/KG	0.4 J	0.53	0.84	0.56	1.1	
Cadmium	2.5	4.3	7.5	MG/KG	1.2 U	1.3 U	0.87 U	1 U	1.1 U	
Calcium	--	--	--	MG/KG	17000	1830	4770	8640	9780	
Chromium III	30	180	--	MG/KG	28.8	<b>35.1</b>	<b>34.4</b>	<b>37.8</b>	<b>94.8</b>	
Chromium, Hexavalent	1	110	19	MG/KG	2.4 U	2.5 U	2.4 U	2.1 U	2.2 U	
Chromium, Total	30	180	--	MG/KG	28.8	<b>35.1</b>	<b>34.4</b>	<b>37.8</b>	<b>94.8</b>	
Cobalt	--	--	--	MG/KG	13.4	11.6	19.4	14.2	22.5	
Copper	50	270	1720	MG/KG	48.2	27.2	48.6	<b>61.4</b>	<b>117</b>	
Cyanide	27	27	40	MG/KG	NA	NA	NA	NA	NA	
Iron	--	--	--	MG/KG	24400	32200	29600	24400	40300	
Lead	63	400	450	MG/KG	38.9	8.3	17.8	15.2	9	
Magnesium	--	--	--	MG/KG	6120	5360	7840	9840	18000	
Manganese	1600	2000	2000	MG/KG	292	383	422	207	399	
Mercury	0.18	0.81	0.73	MG/KG	0.036	0.021	0.012 J	0.018 U	0.018 U	
Nickel	30	310	130	MG/KG	28.2	23.2	<b>42.6</b>	29.3	<b>69.2</b>	
Potassium	--	--	--	MG/KG	5530	3370	8130	7620	8990	
Selenium	3.9	180	4	MG/KG	5.9 U	6.3 U	0.46 J	5.1 U	5.3 U	
Silver	2	180	8.3	MG/KG	1.2 U	1.3 U	0.87 U	1 U	1.1 U	
Sodium	--	--	--	MG/KG	623	257	185	149	333	
Thallium	--	--	--	MG/KG	0.3 J	0.27 J	0.6	0.36 J	0.6	
Vanadium	--	--	--	MG/KG	36.5	46	48.5	41.1	71	
Zinc	109	10000	2480	MG/KG	<b>282</b>	55.5	<b>129</b>	85	<b>140</b>	

**Table 4. Summary of Remaining Metal Exceedances in Soil - 1221 Spofford Avenue, Bronx, New York**

					Sample Designation:	1B-E1-B-18	1B-EP-B-12	1B-EP-B-12	1B-EP-B-20	1B-EP-B-6
					Sample Date:	09/30/2019	10/01/2019	10/01/2019	12/20/2019	10/01/2019
					Sample Depth (ft bls):	0 - 1	0 - 1	0 - 1	0 - 1	0 - 1
					Normal or Field Duplicate:	N	N	FD	N	N
Parameter	NYSDEC Part 375 Unrestricted Use SCO	NYSDEC Part 375 Restricted Residential SCO	NYSDEC Part 375 Protection of Groundwater SCO	Unit						
Aluminum	--	--	--	MG/KG	14000	15700	13000	14600	15500	
Antimony	--	--	--	MG/KG	0.96 U	0.98 U	0.99 U	1.2 U	1.1 U	
Arsenic	13	16	16	MG/KG	1.3	0.79 J	1.2	1.3	1.3	
Barium	350	400	820	MG/KG	168	203	163	152	150	
Beryllium	7.2	72	47	MG/KG	0.54	0.66	0.43	0.69	0.64	
Cadmium	2.5	4.3	7.5	MG/KG	0.96 U	0.98 U	0.99 U	1.2 U	1.1 U	
Calcium	--	--	--	MG/KG	20500	6000	10000	13200	14700	
Chromium III	30	180	--	MG/KG	<b>41.7</b>	<b>46.9</b>	<b>37.5</b>	<b>44</b>	<b>40.2</b>	
Chromium, Hexavalent	1	110	19	MG/KG	2.2 U	2.1 U	2.1 U	2.6 U	2.1 U	
Chromium, Total	30	180	--	MG/KG	<b>41.7</b>	<b>46.9</b>	<b>37.5</b>	<b>44</b>	<b>40.2</b>	
Cobalt	--	--	--	MG/KG	13.2	15	12.3	14.1	13.1	
Copper	50	270	1720	MG/KG	<b>54.3</b>	<b>64</b>	<b>50.8</b>	36.6	38.6	
Cyanide	27	27	40	MG/KG	NA	NA	NA	NA	NA	
Iron	--	--	--	MG/KG	24800	26800	22800	26700	26300	
Lead	63	400	450	MG/KG	24.3	20.6	13.4	21.2	22.8	
Magnesium	--	--	--	MG/KG	16500	9500	10900	10900	10100	
Manganese	1600	2000	2000	MG/KG	252	228	203	286	233	
Mercury	0.18	0.81	0.73	MG/KG	0.011 J	0.017 U	0.017 U	0.016 J	0.01 J	
Nickel	30	310	130	MG/KG	<b>34.2</b>	<b>34.4</b>	28.3	<b>44.6</b>	<b>33.8</b>	
Potassium	--	--	--	MG/KG	7850	9270	7950	8000	8810	
Selenium	3.9	180	4	MG/KG	4.8 U	4.9 U	4.9 U	6 U	5.4 U	
Silver	2	180	8.3	MG/KG	0.96 U	0.98 U	0.99 U	1.2 U	1.1 U	
Sodium	--	--	--	MG/KG	182	151	133	214	245	
Thallium	--	--	--	MG/KG	0.41	0.44	0.39	0.55	0.47	
Vanadium	--	--	--	MG/KG	39.6	48	39.6	41.5	45.9	
Zinc	109	10000	2480	MG/KG	<b>154</b>	103	82.4	102	101	

**Table 4. Summary of Remaining Metal Exceedances in Soil - 1221 Spofford Avenue, Bronx, New York**

					Sample Designation:	1B-EP-B-7	1B-EP-SW-1	1B-EP-SW-2	1B-EP-SW-3	1B-EP-SW-4
					Sample Date:	10/01/2019	09/30/2019	09/30/2019	10/01/2019	12/20/2019
					Sample Depth (ft bls):	0 - 1	0 - 1	0 - 1	0 - 1	0 - 1
					Normal or Field Duplicate:	N	N	N	N	N
Parameter	NYSDEC Part 375 Unrestricted Use SCO	NYSDEC Part 375 Restricted Residential SCO	NYSDEC Part 375 Protection of Groundwater SCO	Unit						
Aluminum	--	--	--	MG/KG	13600	16500	14800	8570	15000	
Antimony	--	--	--	MG/KG	1 U	1.2 U	1.3 U	14.7	1.1 U	
Arsenic	13	16	16	MG/KG	0.68 J	0.81 J	1.6	0.83 J	2.1	
Barium	350	400	820	MG/KG	154	175	169	94.7	167	
Beryllium	7.2	72	47	MG/KG	0.61	0.73	0.82	0.41 J	0.6	
Cadmium	2.5	4.3	7.5	MG/KG	1 U	1.2 U	1.3 U	1.1 U	1.1 U	
Calcium	--	--	--	MG/KG	3710	5540	14600	10700	19500	
Chromium III	30	180	--	MG/KG	<b>38.3</b>	<b>38.8</b>	<b>47.8</b>	21.2	<b>35.3</b>	
Chromium, Hexavalent	1	110	19	MG/KG	2.2 U	2.4 U	2.5 U	2.3 U	2.3 U	
Chromium, Total	30	180	--	MG/KG	<b>38.3</b>	<b>38.8</b>	<b>47.8</b>	21.2	<b>35.3</b>	
Cobalt	--	--	--	MG/KG	13.8	15.7	15.4	8.3	14.1	
Copper	50	270	1720	MG/KG	33.5	35.9	36.8	27.4	41.2	
Cyanide	27	27	40	MG/KG	NA	NA	NA	NA	NA	
Iron	--	--	--	MG/KG	24000	28900	24700	17100	26700	
Lead	63	400	450	MG/KG	14.7	18.9	33	18.6	24.8	
Magnesium	--	--	--	MG/KG	7400	8850	9950	7870	11300	
Manganese	1600	2000	2000	MG/KG	177	239	306	185	284	
Mercury	0.18	0.81	0.73	MG/KG	0.018 U	0.018 U	0.017 J	0.013 J	0.045	
Nickel	30	310	130	MG/KG	<b>39.3</b>	<b>35.7</b>	<b>50.2</b>	20.8	28.6	
Potassium	--	--	--	MG/KG	8960	10200	7730	4980	7140	
Selenium	3.9	180	4	MG/KG	5.2 U	5.8 U	0.43 J	5.3 U	5.5 U	
Silver	2	180	8.3	MG/KG	1 U	1.2 U	1.3 U	1.1 U	1.1 U	
Sodium	--	--	--	MG/KG	169	204	254	158	372	
Thallium	--	--	--	MG/KG	0.42	0.59	0.55	0.28 J	0.4 J	
Vanadium	--	--	--	MG/KG	38.1	46	45.2	27.5	42.8	
Zinc	109	10000	2480	MG/KG	84.4	100	103	<b>111</b>	<b>111</b>	

**Table 4. Summary of Remaining Metal Exceedances in Soil - 1221 Spofford Avenue, Bronx, New York**

					Sample Designation:	1B-EP-SW-6	1B-EP-SW-7	1B-EP-SW-8	1B-EP-SW-9	2A-EB-B-1
					Sample Date:	12/20/2019	09/30/2019	01/03/2020	12/16/2019	04/27/2020
					Sample Depth (ft bls):	0 - 1	0 - 1	0 - 1	0 - 1	0 - 1
					Normal or Field Duplicate:	N	N	N	N	N
Parameter	NYSDEC Part 375 Unrestricted Use SCO	NYSDEC Part 375 Restricted Residential SCO	NYSDEC Part 375 Protection of Groundwater SCO	Unit						
Aluminum	--	--	--	MG/KG	14700	19000	14200	17900	8990	
Antimony	--	--	--	MG/KG	1.1 U	1.1 U	1.1 U	1.1 U	1.2 U	
Arsenic	13	16	16	MG/KG	0.98 J	1.1	1.4	0.77 J	2.4	
Barium	350	400	820	MG/KG	151	219	153	181	128	
Beryllium	7.2	72	47	MG/KG	0.82	0.74	0.61	0.61	0.55	
Cadmium	2.5	4.3	7.5	MG/KG	1.1 U	1.1 U	1.1 U	1.1 U	1.2 U	
Calcium	--	--	--	MG/KG	15200	5940	13600	9010	18900	
Chromium III	30	180	--	MG/KG	<b>40.5</b>	<b>54.1</b>	<b>34.7</b>	<b>54.4</b>	24.6	
Chromium, Hexavalent	1	110	19	MG/KG	2.4 U	2.2 U	2.3 U	2.3 U	2.4 U	
Chromium, Total	30	180	--	MG/KG	<b>40.5</b>	<b>54.1</b>	<b>34.7</b>	<b>54.4</b>	24.6	
Cobalt	--	--	--	MG/KG	14.4	23	16.5	16.1	12.2	
Copper	50	270	1720	MG/KG	34.9	<b>164</b>	44.5	40.5	<b>56.3</b>	
Cyanide	27	27	40	MG/KG	NA	NA	NA	NA	NA	
Iron	--	--	--	MG/KG	27200	37700	24300	30100	19900	
Lead	63	400	450	MG/KG	27.2	16.7	20.4	22.5	<b>65.1</b>	
Magnesium	--	--	--	MG/KG	10600	10800	9620	11100	11500	
Manganese	1600	2000	2000	MG/KG	302	264	264	280	482	
Mercury	0.18	0.81	0.73	MG/KG	0.014 J	0.019 U	0.02	0.013 J	0.063	
Nickel	30	310	130	MG/KG	<b>42.9</b>	<b>35.5</b>	<b>33.9</b>	<b>52.6</b>	22.2	
Potassium	--	--	--	MG/KG	7650	9840	7790	10200	3170	
Selenium	3.9	180	4	MG/KG	5.7 U	5.5 U	5.6 U	5.6 U	5.8 U	
Silver	2	180	8.3	MG/KG	1.1 U	1.1 U	1.1 U	1.1 U	1.2 U	
Sodium	--	--	--	MG/KG	275	146	199	190	196	
Thallium	--	--	--	MG/KG	0.46	0.54	0.42 J	0.52	0.23 J	
Vanadium	--	--	--	MG/KG	43.1	62.8	41.1	49.8	35.4	
Zinc	109	10000	2480	MG/KG	80.8	<b>126</b>	96.2	<b>150</b>	<b>271</b>	



**Table 4. Summary of Remaining Metal Exceedances in Soil - 1221 Spofford Avenue, Bronx, New York**

					Sample Designation:	2A-EP-B-10	2A-EP-B-14	2A-EP-B-15	2A-EP-B-16	2A-EP-B-18
					Sample Date:	04/30/2020	04/14/2020	05/15/2020	04/13/2020	03/11/2020
					Sample Depth (ft bls):	0 - 1	0 - 1	0 - 1	0 - 1	0 - 1
					Normal or Field Duplicate:	N	N	N	N	N
Parameter	NYSDEC Part 375 Unrestricted Use SCO	NYSDEC Part 375 Restricted Residential SCO	NYSDEC Part 375 Protection of Groundwater SCO	Unit						
Aluminum	--	--	--	MG/KG	16000	7440	22700	13200	5910	
Antimony	--	--	--	MG/KG	0.91 U	0.36 J	1 U	0.79 J	0.29 J	
Arsenic	13	16	16	MG/KG	0.66 J	2.7	1 U	4.3	1.2	
Barium	350	400	820	MG/KG	307	115	<b>357</b>	154	55.8	
Beryllium	7.2	72	47	MG/KG	1	0.8	1.2	1.6	0.88	
Cadmium	2.5	4.3	7.5	MG/KG	0.91 U	1.2 U	1 U	0.67 J	0.85 U	
Calcium	--	--	--	MG/KG	4650	22400	2850	52600	53000	
Chromium III	30	180	--	MG/KG	<b>50.1</b>	22.9	<b>42.6</b>	<b>42</b>	20.3	
Chromium, Hexavalent	1	110	19	MG/KG	2.4 U	2.4 U	2.2 U	2.5 U	2.1 U	
Chromium, Total	30	180	--	MG/KG	<b>50.1</b>	22.9	<b>42.6</b>	<b>42</b>	20.3	
Cobalt	--	--	--	MG/KG	17.6	10.3	21.3	18.9	10.2	
Copper	50	270	1720	MG/KG	<b>147</b>	<b>88.8</b>	49.8	<b>197</b>	<b>98.6</b>	
Cyanide	27	27	40	MG/KG	NA	NA	NA	NA	NA	
Iron	--	--	--	MG/KG	31200	18000	41600	30000	14800	
Lead	63	400	450	MG/KG	<b>98.7</b>	<b>91.6</b>	14.9	<b>277</b>	<b>112</b>	
Magnesium	--	--	--	MG/KG	8310	9750	8580	22100	30200	
Manganese	1600	2000	2000	MG/KG	251	310	283	504	330	
Mercury	0.18	0.81	0.73	MG/KG	0.0099 J	0.078	0.0044 J	0.022	0.0096 J	
Nickel	30	310	130	MG/KG	<b>38.1</b>	21.5	<b>40.1</b>	<b>44.1</b>	24.9	
Potassium	--	--	--	MG/KG	8520	2660	15200	4040	1480	
Selenium	3.9	180	4	MG/KG	1 J	5.9 U	5.1 U	6 U	4.2 U	
Silver	2	180	8.3	MG/KG	0.91 U	1.2 U	1 U	1.2 U	0.85 U	
Sodium	--	--	--	MG/KG	198	278	156	397	223	
Thallium	--	--	--	MG/KG	0.39	0.17 J	0.69	0.29 J	0.12 J	
Vanadium	--	--	--	MG/KG	50.2	25.1	54.3	41.8	20.8	
Zinc	109	10000	2480	MG/KG	<b>781</b>	<b>543</b>	<b>111</b>	<b>1720</b>	<b>807</b>	

**Table 4. Summary of Remaining Metal Exceedances in Soil - 1221 Spofford Avenue, Bronx, New York**

					Sample Designation:	2A-EP-B-18	2A-EP-B-19	2A-EP-B-20	2A-EP-B-21	2A-EP-B-22
					Sample Date:	03/11/2020	04/14/2020	04/14/2020	04/30/2020	04/14/2020
					Sample Depth (ft bls):	0 - 1	0 - 1	0 - 1	0 - 1	0 - 1
					Normal or Field Duplicate:	FD	N	N	N	N
Parameter	NYSDEC Part 375 Unrestricted Use SCO	NYSDEC Part 375 Restricted Residential SCO	NYSDEC Part 375 Protection of Groundwater SCO	Unit						
Aluminum	--	--	--	MG/KG	6310	9970	5280	12700	13600	
Antimony	--	--	--	MG/KG	0.81 U	1.1 U	0.67 J	0.93 U	1.2 U	
Arsenic	13	16	16	MG/KG	1	0.96 J	2	1.3	0.77 J	
Barium	350	400	820	MG/KG	55.9	147	133	158	199	
Beryllium	7.2	72	47	MG/KG	0.46	0.51	1.5	0.68	0.57	
Cadmium	2.5	4.3	7.5	MG/KG	0.81 U	1.1 U	1.1 U	0.93 U	1.2 U	
Calcium	--	--	--	MG/KG	54200	20400	2570	14700	3410	
Chromium III	30	180	--	MG/KG	15.9	21.6	<b>35.1</b>	<b>33.4</b>	<b>32.4</b>	
Chromium, Hexavalent	1	110	19	MG/KG	2.2 U	2.2 U	2.3 U	2.5 U	2.4 U	
Chromium, Total	30	180	--	MG/KG	15.9	21.6	<b>35.1</b>	<b>33.4</b>	<b>32.4</b>	
Cobalt	--	--	--	MG/KG	6.7	10.4	18.2	12.8	12.3	
Copper	50	270	1720	MG/KG	25.2	<b>58.6</b>	<b>304</b>	<b>78.8</b>	<b>52.9</b>	
Cyanide	27	27	40	MG/KG	NA	NA	NA	NA	NA	
Iron	--	--	--	MG/KG	12900	20200	19500	24200	25800	
Lead	63	400	450	MG/KG	21	17	<b>293</b>	57	18.3	
Magnesium	--	--	--	MG/KG	28700	14500	3070	7340	6650	
Manganese	1600	2000	2000	MG/KG	335	148	258	343	272	
Mercury	0.18	0.81	0.73	MG/KG	0.016 U	0.01 J	<b>0.19</b>	0.02 J	0.012 J	
Nickel	30	310	130	MG/KG	12.4	19.7	<b>47.4</b>	29.6	25.4	
Potassium	--	--	--	MG/KG	1450	6490	1480	6090	8350	
Selenium	3.9	180	4	MG/KG	4 U	5.3 U	5.6 U	4.6 U	5.8 U	
Silver	2	180	8.3	MG/KG	0.81 U	1.1 U	1.1 U	0.93 U	1.2 U	
Sodium	--	--	--	MG/KG	147	97.5 J	203	184	234	
Thallium	--	--	--	MG/KG	0.1 J	0.28 J	0.45 U	0.31 J	0.36 J	
Vanadium	--	--	--	MG/KG	19	27.8	16.9	39.4	40.7	
Zinc	109	10000	2480	MG/KG	<b>154</b>	95	<b>1870</b>	<b>408</b>	77	

**Table 4. Summary of Remaining Metal Exceedances in Soil - 1221 Spofford Avenue, Bronx, New York**

					Sample Designation:	2A-EP-B-23	2A-EP-B-24	2A-EP-B-3	2A-EP-B-6	2A-EP-B-9
					Sample Date:	04/16/2020	04/21/2020	03/13/2020	03/13/2020	03/13/2020
					Sample Depth (ft bls):	0 - 1	0 - 1	0 - 1	0 - 1	0 - 1
					Normal or Field Duplicate:	N	N	N	N	N
Parameter	NYSDEC Part 375 Unrestricted Use SCO	NYSDEC Part 375 Restricted Residential SCO	NYSDEC Part 375 Protection of Groundwater SCO	Unit						
Aluminum	--	--	--	MG/KG	14800	8960	5800	5910	7690	
Antimony	--	--	--	MG/KG	0.43 J	1.1 U	1 U	1 U	0.46 J	
Arsenic	13	16	16	MG/KG	2.5	3.6	0.99 J	1.5	1.7	
Barium	350	400	820	MG/KG	272	122	54.3	57.8	110	
Beryllium	7.2	72	47	MG/KG	1.1	0.67	0.66	0.4 J	1.7	
Cadmium	2.5	4.3	7.5	MG/KG	0.51 J	1.1 U	1 U	1 U	1.1 U	
Calcium	--	--	--	MG/KG	18600	19200	38600	22000	21500	
Chromium III	30	180	--	MG/KG	<b>36.5</b>	22.6	14.7	15.1	<b>37.2</b>	
Chromium, Hexavalent	1	110	19	MG/KG	3 U	2.4 U	2.2 U	0.4 J	0.45 J	
Chromium, Total	30	180	--	MG/KG	<b>36.5</b>	22.6	14.7	15.5	<b>37.6</b>	
Cobalt	--	--	--	MG/KG	16.7	9.6	8.5	6.6	18.8	
Copper	50	270	1720	MG/KG	<b>200</b>	48.1	43.1	20.5	<b>258</b>	
Cyanide	27	27	40	MG/KG	NA	NA	NA	NA	NA	
Iron	--	--	--	MG/KG	28800	18900	14900	13600	22000	
Lead	63	400	450	MG/KG	<b>166</b>	<b>64.2</b>	25.2	<b>79.4</b>	<b>233</b>	
Magnesium	--	--	--	MG/KG	8180	9270	20800	13100	11000	
Manganese	1600	2000	2000	MG/KG	340	411	388	303	373	
Mercury	0.18	0.81	0.73	MG/KG	0.097	0.04	0.011 J	0.028	0.017	
Nickel	30	310	130	MG/KG	<b>41.8</b>	19.5	14.4	12.6	<b>40.7</b>	
Potassium	--	--	--	MG/KG	8430	3000	1690	1790	2370	
Selenium	3.9	180	4	MG/KG	6.8 U	5.7 U	5 U	5.2 U	5.5 U	
Silver	2	180	8.3	MG/KG	1.4 U	1.1 U	1 U	1 U	1.1 U	
Sodium	--	--	--	MG/KG	282	203	170	96.9 J	531	
Thallium	--	--	--	MG/KG	0.41 J	0.22 J	0.4 U	0.15 J	0.44 U	
Vanadium	--	--	--	MG/KG	43.1	32.4	20.8	24.2	22	
Zinc	109	10000	2480	MG/KG	<b>593</b>	<b>262</b>	<b>264</b>	60.8	<b>2110</b>	

**Table 4. Summary of Remaining Metal Exceedances in Soil - 1221 Spofford Avenue, Bronx, New York**

					Sample Designation:	2A-EP-SW-3	2B-EP-B-1	2B-EP-B-1	2B-EP-B-11	2B-EP-B-14
					Sample Date:	04/21/2020	05/05/2020	05/05/2020	04/16/2020	05/27/2020
					Sample Depth (ft bls):	0 - 1	0 - 1	0 - 1	0 - 1	0 - 1
					Normal or Field Duplicate:	N	N	FD	N	N
Parameter	NYSDEC Part 375 Unrestricted Use SCO	NYSDEC Part 375 Restricted Residential SCO	NYSDEC Part 375 Protection of Groundwater SCO	Unit						
Aluminum	--	--	--	MG/KG	4070	10600	10100	19300	19700	
Antimony	--	--	--	MG/KG	1 U	1 U	1.1 U	1.3 U	1.1 U	
Arsenic	13	16	16	MG/KG	1.7	1.3	1.5	0.52 J	1.1 U	
Barium	350	400	820	MG/KG	138	166	160	200	275	
Beryllium	7.2	72	47	MG/KG	1.1	0.65	0.44	0.8	1.4	
Cadmium	2.5	4.3	7.5	MG/KG	1 U	1 U	1.1 U	1.3 U	1.1 U	
Calcium	--	--	--	MG/KG	4340	10100	12500	2780	656	
Chromium III	30	180	--	MG/KG	19.1	27.1	25.2	<b>52.7</b>	<b>42.9</b>	
Chromium, Hexavalent	1	110	19	MG/KG	0.57 J	2.3 U	2.3 U	2.6 U	2.3 U	
Chromium, Total	30	180	--	MG/KG	19.6	27.1	25.2	<b>52.7</b>	<b>42.9</b>	
Cobalt	--	--	--	MG/KG	8.7	13	10.9	20.3	19.2	
Copper	50	270	1720	MG/KG	<b>115</b>	<b>81.5</b>	<b>85.5</b>	<b>72.2</b>	40	
Cyanide	27	27	40	MG/KG	NA	NA	NA	NA	NA	
Iron	--	--	--	MG/KG	12000	23800	22800	38900	36600	
Lead	63	400	450	MG/KG	<b>327</b>	<b>67.3</b>	43.4	38.4	12.3	
Magnesium	--	--	--	MG/KG	2860	5930	7100	9590	6980	
Manganese	1600	2000	2000	MG/KG	297	256	279	607	189	
Mercury	0.18	0.81	0.73	MG/KG	<b>0.36</b>	0.016 J	0.019	0.021 U	0.018 U	
Nickel	30	310	130	MG/KG	25.1	26.4	27.6	<b>44.8</b>	<b>33.4</b>	
Potassium	--	--	--	MG/KG	1270	4990	5790	9390	14600	
Selenium	3.9	180	4	MG/KG	5.2 U	5.2 U	5.3 U	6.3 U	5.5 U	
Silver	2	180	8.3	MG/KG	1 U	1 U	1.1 U	1.3 U	1.1 U	
Sodium	--	--	--	MG/KG	157	194	176	144	163	
Thallium	--	--	--	MG/KG	0.42 U	0.22 J	0.23 J	0.43 J	0.79	
Vanadium	--	--	--	MG/KG	13.9	29.2	31.1	70.8	42.9	
Zinc	109	10000	2480	MG/KG	<b>778</b>	<b>427</b>	<b>267</b>	101	<b>111</b>	

**Table 4. Summary of Remaining Metal Exceedances in Soil - 1221 Spofford Avenue, Bronx, New York**

					Sample Designation:	2B-EP-B-17	2B-EP-B-18	2B-EP-B-2	2B-EP-B-21	2B-EP-B-22
					Sample Date:	05/08/2020	05/26/2020	05/15/2020	05/08/2020	05/15/2020
					Sample Depth (ft bls):	0 - 1	0 - 1	0 - 1	0 - 1	0 - 1
					Normal or Field Duplicate:	N	N	N	N	N
Parameter	NYSDEC Part 375 Unrestricted Use SCO	NYSDEC Part 375 Restricted Residential SCO	NYSDEC Part 375 Protection of Groundwater SCO	Unit						
Aluminum	--	--	--	MG/KG	7010	10300	18400	6730	10900	
Antimony	--	--	--	MG/KG	1 U	1.1 U	0.53 J	1 U	1.1 U	
Arsenic	13	16	16	MG/KG	0.93 J	0.93 J	3.3	0.86 J	1.7	
Barium	350	400	820	MG/KG	63.4	130	211	64.6	94.3	
Beryllium	7.2	72	47	MG/KG	0.43	0.66	1.3	0.33 J	0.73	
Cadmium	2.5	4.3	7.5	MG/KG	1 U	1.1 U	0.36 J	1 U	1.1 U	
Calcium	--	--	--	MG/KG	13800	7730	32300	11700	22300	
Chromium III	30	180	--	MG/KG	19.7	27.7	<b>40.8</b>	18.5	<b>40.9</b>	
Chromium, Hexavalent	1	110	19	MG/KG	2.2 U	2.2 U	2.2 U	2.2 U	2.3 U	
Chromium, Total	30	180	--	MG/KG	19.7	27.7	<b>40.8</b>	18.5	<b>40.9</b>	
Cobalt	--	--	--	MG/KG	7.6	12.8	16.2	7.7	11.1	
Copper	50	270	1720	MG/KG	32.8	<b>72.4</b>	<b>69.6</b>	42.5	26.3	
Cyanide	27	27	40	MG/KG	NA	NA	NA	NA	NA	
Iron	--	--	--	MG/KG	15700	24000	37100	15500	25300	
Lead	63	400	450	MG/KG	24	<b>67.9</b>	<b>117</b>	29.4	7.2	
Magnesium	--	--	--	MG/KG	7360	6920	16500	7270	14900	
Manganese	1600	2000	2000	MG/KG	276	314	603	250	575	
Mercury	0.18	0.81	0.73	MG/KG	0.017 U	0.0085 J	0.023	0.025	0.0064 J	
Nickel	30	310	130	MG/KG	16.1	25.3	<b>34.2</b>	15.8	21	
Potassium	--	--	--	MG/KG	1880	4820	6910	2310	2650	
Selenium	3.9	180	4	MG/KG	5.1 U	5.4 U	0.33 J	5.2 U	5.3 U	
Silver	2	180	8.3	MG/KG	1 U	1.1 U	1 U	1 U	1.1 U	
Sodium	--	--	--	MG/KG	253	186	271	265	326	
Thallium	--	--	--	MG/KG	0.41 U	0.27 J	0.45	0.41 U	0.19 J	
Vanadium	--	--	--	MG/KG	33	32.9	55.4	29.7	38.2	
Zinc	109	10000	2480	MG/KG	<b>138</b>	<b>474</b>	<b>330</b>	<b>237</b>	52	

**Table 4. Summary of Remaining Metal Exceedances in Soil - 1221 Spofford Avenue, Bronx, New York**

					Sample Designation:	2B-EP-B-27	2B-EP-B-28	2B-EP-B-29	2B-EP-B-3	2B-EP-B-30
					Sample Date:	04/16/2020	04/16/2020	05/22/2020	05/15/2020	05/08/2020
					Sample Depth (ft bls):	0 - 1	0 - 1	0 - 1	0 - 1	0 - 1
					Normal or Field Duplicate:	N	N	N	N	N
Parameter	NYSDEC Part 375 Unrestricted Use SCO	NYSDEC Part 375 Restricted Residential SCO	NYSDEC Part 375 Protection of Groundwater SCO	Unit						
Aluminum	--	--	--	MG/KG	11600	11000	15000	27600	9240	
Antimony	--	--	--	MG/KG	0.37 J	0.52 J	0.91 U	1.1 U	1.1 U	
Arsenic	13	16	16	MG/KG	1.9	1.6	0.91 U	0.58 J	1.1	
Barium	350	400	820	MG/KG	209	162	250	<b>358</b>	82.7	
Beryllium	7.2	72	47	MG/KG	1.4	1.7	0.87	1.4	0.59	
Cadmium	2.5	4.3	7.5	MG/KG	1.2 U	1.2 U	0.91 U	1.1 U	1.1 U	
Calcium	--	--	--	MG/KG	23500	19200	2010	2950	20500	
Chromium III	30	180	--	MG/KG	<b>35.4</b>	<b>48.7</b>	<b>33.7</b>	<b>49.6</b>	26.1	
Chromium, Hexavalent	1	110	19	MG/KG	2.5 U	2.6 U	2.2 U	2.3 U	2.2 U	
Chromium, Total	30	180	--	MG/KG	<b>35.4</b>	<b>48.7</b>	<b>33.7 B</b>	<b>49.6</b>	26.1	
Cobalt	--	--	--	MG/KG	18.7	28	19	23.1	9.8	
Copper	50	270	1720	MG/KG	<b>179</b>	<b>322</b>	32.2	<b>90.9</b>	<b>56.4</b>	
Cyanide	27	27	40	MG/KG	NA	NA	NA	NA	NA	
Iron	--	--	--	MG/KG	32700	32300	23800	51500	20600	
Lead	63	400	450	MG/KG	<b>185</b>	<b>247</b>	18.4	13.4	35.3	
Magnesium	--	--	--	MG/KG	8360	6820	7180	11100	8390	
Manganese	1600	2000	2000	MG/KG	421	363	145	232	438	
Mercury	0.18	0.81	0.73	MG/KG	0.095	0.038	0.018 U	0.0051 J	0.005 J	
Nickel	30	310	130	MG/KG	<b>38.7</b>	<b>52</b>	<b>40.4</b>	<b>49.5</b>	20.5	
Potassium	--	--	--	MG/KG	5740	5600	9710	19000	2470	
Selenium	3.9	180	4	MG/KG	5.8 U	6.1 U	0.3 J	5.3 U	5.3 U	
Silver	2	180	8.3	MG/KG	1.2 U	1.2 U	0.91 U	1.1 U	1.1 U	
Sodium	--	--	--	MG/KG	301	357	181	272	264	
Thallium	--	--	--	MG/KG	0.32 J	0.34 J	0.51	0.91	0.14 J	
Vanadium	--	--	--	MG/KG	39.1	31.6	46.4	65.4	39	
Zinc	109	10000	2480	MG/KG	<b>1110</b>	<b>1800</b>	<b>207</b>	<b>138</b>	<b>207</b>	

**Table 4. Summary of Remaining Metal Exceedances in Soil - 1221 Spofford Avenue, Bronx, New York**

					Sample Designation:	2B-EP-B-31	2B-EP-B-32	2B-EP-B-4	2B-EP-B-5	2B-EP-B-6
					Sample Date:	05/15/2020	05/15/2020	05/15/2020	05/05/2020	04/16/2020
					Sample Depth (ft bls):	0 - 1	0 - 1	0 - 1	0 - 1	0 - 1
					Normal or Field Duplicate:	N	N	N	N	N
Parameter	NYSDEC Part 375 Unrestricted Use SCO	NYSDEC Part 375 Restricted Residential SCO	NYSDEC Part 375 Protection of Groundwater SCO	Unit						
Aluminum	--	--	--	MG/KG	35400	38000	16000	13500	9970	
Antimony	--	--	--	MG/KG	1 U	1 U	1.4	1 U	0.63 J	
Arsenic	13	16	16	MG/KG	1.2	1.1	2.8	0.66 J	1.8	
Barium	350	400	820	MG/KG	<b>562</b>	348	203	152	194	
Beryllium	7.2	72	47	MG/KG	2	0.67	1.3	0.62	2.4	
Cadmium	2.5	4.3	7.5	MG/KG	1 U	1 U	0.95 U	1 U	1.1 U	
Calcium	--	--	--	MG/KG	14600	1430	23100	4150	18100	
Chromium III	30	180	--	MG/KG	<b>67.9</b>	<b>164</b>	<b>41.1</b>	25.4	<b>57.7</b>	
Chromium, Hexavalent	1	110	19	MG/KG	2.2 U	2.3 U	2.1 U	2.2 U	2.4 U	
Chromium, Total	30	180	--	MG/KG	<b>67.9</b>	<b>164</b>	<b>41.1</b>	25.4	<b>57.7</b>	
Cobalt	--	--	--	MG/KG	34.6	26.5	16.6	11.9	28.3	
Copper	50	270	1720	MG/KG	48.6	<b>57.2</b>	<b>106</b>	<b>53.4</b>	<b>406</b>	
Cyanide	27	27	40	MG/KG	NA	NA	NA	NA	NA	
Iron	--	--	--	MG/KG	65400	61200	34300	26700	30300	
Lead	63	400	450	MG/KG	<b>78.6</b>	16.2	<b>265</b>	35.8	<b>352</b>	
Magnesium	--	--	--	MG/KG	20200	21700	9770	5330	7010	
Manganese	1600	2000	2000	MG/KG	<b>1740</b>	577	462	215	371	
Mercury	0.18	0.81	0.73	MG/KG	0.0049 J	0.0052 J	0.0083 J	0.0044 J	0.06	
Nickel	30	310	130	MG/KG	<b>61.7</b>	<b>95.7</b>	<b>36.5</b>	25.5	<b>55.6</b>	
Potassium	--	--	--	MG/KG	21300	26800	8190	9360	4650	
Selenium	3.9	180	4	MG/KG	5.1 U	0.44 J	4.8 U	5.1 U	5.6 U	
Silver	2	180	8.3	MG/KG	1 U	1 U	0.95 U	1 U	1.1 U	
Sodium	--	--	--	MG/KG	276	453	340	125	443	
Thallium	--	--	--	MG/KG	0.89	1.8	0.41	0.41	0.22 J	
Vanadium	--	--	--	MG/KG	119	127	42.8	32.1	27.1	
Zinc	109	10000	2480	MG/KG	<b>500</b>	<b>200</b>	<b>728</b>	<b>217</b>	<b>2430</b>	

**Table 4. Summary of Remaining Metal Exceedances in Soil - 1221 Spofford Avenue, Bronx, New York**

					Sample Designation:	2B-EP-B-8	2B-EP-SW-1	2B-EP-SW-2	IA-EP-B-15	IA-EP-SW-8
					Sample Date:	05/26/2020	05/26/2020	05/27/2020	10/11/2019	11/05/2019
					Sample Depth (ft bls):	0 - 1	0 - 1	0 - 1	0 - 1	0 - 1
					Normal or Field Duplicate:	N	N	N	N	N
Parameter	NYSDEC Part 375 Unrestricted Use SCO	NYSDEC Part 375 Restricted Residential SCO	NYSDEC Part 375 Protection of Groundwater SCO	Unit						
Aluminum	--	--	--	MG/KG	15500	11000	9780	20700	13100	
Antimony	--	--	--	MG/KG	1 U	0.35 J	1.1 U	1.1 U	0.94 U	
Arsenic	13	16	16	MG/KG	1 U	2.6	1 J	0.72 J	1.5	
Barium	350	400	820	MG/KG	168	167	134	183	142	
Beryllium	7.2	72	47	MG/KG	1	0.99	0.77	1.1	0.5	
Cadmium	2.5	4.3	7.5	MG/KG	1 U	1 U	1.1 U	1.1 U	0.94 U	
Calcium	--	--	--	MG/KG	1230	11100	7270	5550	14600	
Chromium III	30	180	--	MG/KG	30	<b>38.4</b>	23	<b>113</b>	<b>31.3</b>	
Chromium, Hexavalent	1	110	19	MG/KG	2.2 U	2.2 U	2.2 U	2.2 U	2.4 U	
Chromium, Total	30	180	--	MG/KG	30	<b>38.4</b>	23	<b>113</b>	<b>31.3</b>	
Cobalt	--	--	--	MG/KG	14.9	17.3	11.3	23.4	13.4	
Copper	50	270	1720	MG/KG	<b>62</b>	<b>180</b>	33.6	34.4	37.4	
Cyanide	27	27	40	MG/KG	NA	NA	NA	NA	NA	
Iron	--	--	--	MG/KG	28900	25300	23900	32700	25200	
Lead	63	400	450	MG/KG	12.7	<b>153</b>	33.8	22.2	18.8	
Magnesium	--	--	--	MG/KG	5860	7890	5970	14100	11200	
Manganese	1600	2000	2000	MG/KG	69.2	392	476	294	344	
Mercury	0.18	0.81	0.73	MG/KG	0.0065 J	0.058	0.0095 J	0.017 U	0.014 J	
Nickel	30	310	130	MG/KG	<b>35.7</b>	<b>34.7</b>	21.6	<b>124</b>	<b>30.6</b>	
Potassium	--	--	--	MG/KG	9730	3000	4710	9070	6500	
Selenium	3.9	180	4	MG/KG	5.2 U	5.2 U	5.4 U	5.5 U	4.7 U	
Silver	2	180	8.3	MG/KG	1 U	1 U	1.1 U	1.1 U	0.94 U	
Sodium	--	--	--	MG/KG	170	224	149	194	190	
Thallium	--	--	--	MG/KG	0.45	0.22 J	0.25 J	0.52	0.39	
Vanadium	--	--	--	MG/KG	38.3	36.1	32.2	51.1	41.6	
Zinc	109	10000	2480	MG/KG	77.4	<b>993</b>	<b>154</b>	<b>133</b>	86.7	



**Table 4. Summary of Remaining Metal Exceedances in Soil - 1221 Spofford Avenue, Bronx, New York**

					Sample Designation:	<b>RXSB-13</b>
					Sample Date:	<b>11/26/2018</b>
					Sample Depth (ft bls):	<b>16 - 18</b>
					Normal or Field Duplicate:	<b>N</b>
Parameter	NYSDEC Part 375 Unrestricted Use SCO	NYSDEC Part 375 Restricted Residential SCO	NYSDEC Part 375 Protection of Groundwater SCO	Unit		
Aluminum	--	--	--	MG/KG		13500
Antimony	--	--	--	MG/KG		1.1 U
Arsenic	13	16	16	MG/KG		1 J
Barium	350	400	820	MG/KG		138
Beryllium	7.2	72	47	MG/KG		0.5
Cadmium	2.5	4.3	7.5	MG/KG		1.1 U
Calcium	--	--	--	MG/KG		6660
Chromium III	30	180	--	MG/KG		<b>31.5</b>
Chromium, Hexavalent	1	110	19	MG/KG		2.4 U
Chromium, Total	30	180	--	MG/KG		<b>31.5</b>
Cobalt	--	--	--	MG/KG		13.5
Copper	50	270	1720	MG/KG		46.6
Cyanide	27	27	40	MG/KG		0.25 U
Iron	--	--	--	MG/KG		24300
Lead	63	400	450	MG/KG		33.6
Magnesium	--	--	--	MG/KG		8400
Manganese	1600	2000	2000	MG/KG		349
Mercury	0.18	0.81	0.73	MG/KG		0.019 J
Nickel	30	310	130	MG/KG		<b>31.4</b>
Potassium	--	--	--	MG/KG		6530
Selenium	3.9	180	4	MG/KG		0.53 J
Silver	2	180	8.3	MG/KG		1.1 U
Sodium	--	--	--	MG/KG		165
Thallium	--	--	--	MG/KG		0.45
Vanadium	--	--	--	MG/KG		43.8
Zinc	109	10000	2480	MG/KG		99.4

**Table 5. Summary of Remaining Pesticide and Herbicide Exceedances in Soil - 1221 Spofford Avenue, Bronx, New York**

Parameter	NYSDEC Part 375 Unrestricted Use SCO	NYSDEC Part 375 Restricted Residential SCO	NYSDEC Part 375 Protection of Groundwater SCO	Unit	Sample Designation:	1A-EP-B-1	1A-EP-B-2	1A-EP-SW-4
					Sample Date:	06/25/2019	06/25/2019	09/30/2019
					Sample Depth (ft bls):	9 - 11	8 - 10	0 - 1
					Normal or Field Duplicate:	N	N	N
2,4-D (Dichlorophenoxyacetic Acid)	--	--	--	MG/KG	NA	NA	0.037 U	
Acetic acid, (2,4,5-trichlorophenoxy)-	--	--	--	MG/KG	NA	NA	0.037 U	
Aldrin	0.005	0.097	0.19	MG/KG	0.0078 U	0.0075 U	0.0075 U	
Alpha Bhc (Alpha Hexachlorocyclohexane)	0.02	0.48	0.02	MG/KG	0.0023 U	0.0022 U	0.0022 U	
Alpha Endosulfan	2.4	24	102	MG/KG	0.0078 U	0.0075 U	0.0075 U	
Beta Bhc (Beta Hexachlorocyclohexane)	0.036	0.36	0.09	MG/KG	0.0023 U	0.0022 U	0.0022 U	
Beta Endosulfan	2.4	24	102	MG/KG	0.0078 U	0.0075 U	0.0075 U	
Chlordane	--	--	--	MG/KG	0.078 U	0.075 U	NA	
cis-Chlordane	0.094	4.2	2.9	MG/KG	0.0078 U	0.0075 U	0.0075 U	
Delta BHC (Delta Hexachlorocyclohexane)	0.04	100	0.25	MG/KG	0.0023 U	0.0022 U	0.0022 U	
Dieldrin	0.005	0.2	0.1	MG/KG	0.0023 U	0.0022 U	0.0022 U	
Endosulfan Sulfate	2.4	24	1000	MG/KG	0.0078 U	0.0075 U	0.0075 U	
Endrin	0.014	11	0.06	MG/KG	0.0078 U	0.0075 U	0.0075 U	
Endrin Aldehyde	--	--	--	MG/KG	0.0078 U	0.0075 U	0.0075 U	
Endrin Ketone	--	--	--	MG/KG	0.0078 UT	0.0075 UT	0.0075 U	
Gamma Bhc (Lindane)	0.1	1.3	0.1	MG/KG	0.0023 U	0.0022 U	0.0022 U	
Heptachlor	0.042	2.1	0.38	MG/KG	0.0078 U	0.0075 U	0.0075 U	
Heptachlor Epoxide	--	--	--	MG/KG	0.0078 U	0.0075 U	0.0075 U	
Methoxychlor	--	--	--	MG/KG	0.0078 U	0.0075 U	0.0075 U	
P,P'-DDD	0.0033	13	14	MG/KG	0.0078 U	0.0075 U	0.0075 U	
P,P'-DDE	0.0033	8.9	17	MG/KG	<b>0.0043 J</b>	<b>0.011</b>	0.0075 U	
P,P'-DDT	0.0033	7.9	136	MG/KG	0.003 J	0.003 J	<b>0.0035 J</b>	
Silvex (2,4,5-TP)	3.8	100	3.8	MG/KG	NA	NA	0.037 U	
Toxaphene	--	--	--	MG/KG	0.078 U	0.075 U	0.075 U	
trans-Chlordane	--	--	--	MG/KG	0.0078 U	0.0075 U	0.0075 U	

**Table 5. Summary of Remaining Pesticide and Herbicide Exceedances in Soil - 1221 Spofford Avenue, Bronx, New York**

Parameter	NYSDEC Part 375 Unrestricted Use SCO	NYSDEC Part 375 Restricted Residential SCO	NYSDEC Part 375 Protection of Groundwater SCO	Unit	Sample Designation:	1B-EP-SW-2	2A-EP-B-14	2A-EP-B-16
					Sample Date:	09/30/2019	04/14/2020	04/13/2020
					Sample Depth (ft bls):	0 - 0	0 - 0	0 - 0
					Normal or Field Duplicate:	N	N	N
2,4-D (Dichlorophenoxyacetic Acid)	--	--	--	MG/KG	0.042 U	0.04 U	0.041 U	
Acetic acid, (2,4,5-trichlorophenoxy)-	--	--	--	MG/KG	0.042 U	0.04 U	0.041 U	
Aldrin	0.005	0.097	0.19	MG/KG	0.0085 U	0.008 U	0.0082 U	
Alpha Bhc (Alpha Hexachlorocyclohexane)	0.02	0.48	0.02	MG/KG	0.0025 U	0.0024 U	0.0025 U	
Alpha Endosulfan	2.4	24	102	MG/KG	0.0085 U	0.008 U	0.0082 U	
Beta Bhc (Beta Hexachlorocyclohexane)	0.036	0.36	0.09	MG/KG	0.0025 U	0.0024 U	0.0025 U	
Beta Endosulfan	2.4	24	102	MG/KG	0.0085 U	0.008 U	0.0082 U	
Chlordane	--	--	--	MG/KG	NA	NA	NA	
cis-Chlordane	0.094	4.2	2.9	MG/KG	0.0085 U	0.008 U	0.0082 U	
Delta BHC (Delta Hexachlorocyclohexane)	0.04	100	0.25	MG/KG	0.0025 U	0.0024 U	0.0025 U	
Dieldrin	0.005	0.2	0.1	MG/KG	0.0025 U	0.0024 U	0.0025 U	
Endosulfan Sulfate	2.4	24	1000	MG/KG	0.0085 U	0.008 U	0.0082 U	
Endrin	0.014	11	0.06	MG/KG	0.0085 U	0.008 U	0.0082 U	
Endrin Aldehyde	--	--	--	MG/KG	0.0085 U	0.008 U	0.0082 U	
Endrin Ketone	--	--	--	MG/KG	0.0085 U	0.008 U	0.0082 U	
Gamma Bhc (Lindane)	0.1	1.3	0.1	MG/KG	0.0025 U	0.0024 U	0.0025 U	
Heptachlor	0.042	2.1	0.38	MG/KG	0.0085 U	0.008 U	0.0082 U	
Heptachlor Epoxide	--	--	--	MG/KG	0.0085 U	0.008 U	0.0082 U	
Methoxychlor	--	--	--	MG/KG	0.0085 U	0.008 U	0.0082 U	
P,P'-DDD	0.0033	13	14	MG/KG	0.0025 JP	0.008 U	0.003 J	
P,P'-DDE	0.0033	8.9	17	MG/KG	<b>0.006 J</b>	0.008 U	<b>0.0058 J</b>	
P,P'-DDT	0.0033	7.9	136	MG/KG	<b>0.045</b>	<b>0.0041 J</b>	<b>0.0063 J</b>	
Silvex (2,4,5-TP)	3.8	100	3.8	MG/KG	0.042 U	0.04 U	0.041 U	
Toxaphene	--	--	--	MG/KG	0.085 U	0.08 U	0.082 U	
trans-Chlordane	--	--	--	MG/KG	0.0085 U	0.008 U	0.0082 U	

**Table 5. Summary of Remaining Pesticide and Herbicide Exceedances in Soil - 1221 Spofford Avenue, Bronx, New York**

Parameter	NYSDEC Part 375 Unrestricted Use SCO	NYSDEC Part 375 Restricted Residential SCO	NYSDEC Part 375 Protection of Groundwater SCO	Unit	Sample Designation:	2A-EP-B-21	2A-EP-B-24	2A-EP-SW-3
					Sample Date:	04/30/2020	04/21/2020	04/21/2020
					Sample Depth (ft bls):	0 - 1	0 - 1	0 - 1
					Normal or Field Duplicate:	N	N	N
2,4-D (Dichlorophenoxyacetic Acid)	--	--	--	MG/KG	0.041 U	0.039 U	0.036 U	
Acetic acid, (2,4,5-trichlorophenoxy)-	--	--	--	MG/KG	0.041 U	0.039 U	0.036 U	
Aldrin	0.005	0.097	0.19	MG/KG	0.0083 U	0.0078 U	0.0073 U	
Alpha Bhc (Alpha Hexachlorocyclohexane)	0.02	0.48	0.02	MG/KG	0.0025 U	0.0023 U	0.0022 U	
Alpha Endosulfan	2.4	24	102	MG/KG	0.0083 U	0.0078 U	0.0073 U	
Beta Bhc (Beta Hexachlorocyclohexane)	0.036	0.36	0.09	MG/KG	0.0025 U	0.0023 U	0.0022 U	
Beta Endosulfan	2.4	24	102	MG/KG	0.0083 U	0.0078 U	0.0073 U	
Chlordane	--	--	--	MG/KG	NA	NA	NA	
cis-Chlordane	0.094	4.2	2.9	MG/KG	0.0083 U	0.0078 U	0.0073 U	
Delta BHC (Delta Hexachlorocyclohexane)	0.04	100	0.25	MG/KG	0.0025 U	0.0023 U	0.0022 U	
Dieldrin	0.005	0.2	0.1	MG/KG	0.0025 U	0.0023 U	0.0022 U	
Endosulfan Sulfate	2.4	24	1000	MG/KG	0.0083 U	0.0078 U	0.0073 U	
Endrin	0.014	11	0.06	MG/KG	0.0083 U	0.0078 U	0.0073 U	
Endrin Aldehyde	--	--	--	MG/KG	0.0083 U	0.0078 U	0.0073 U	
Endrin Ketone	--	--	--	MG/KG	0.0083 U	0.0078 U	0.0073 U	
Gamma Bhc (Lindane)	0.1	1.3	0.1	MG/KG	0.0025 U	0.0023 U	0.0022 U	
Heptachlor	0.042	2.1	0.38	MG/KG	0.0083 U	0.0078 U	0.0073 U	
Heptachlor Epoxide	--	--	--	MG/KG	0.0083 U	0.0078 U	0.0073 U	
Methoxychlor	--	--	--	MG/KG	0.0083 U	0.0078 U	0.0073 U	
P,P'-DDD	0.0033	13	14	MG/KG	<b>0.008 J</b>	0.0078 U	0.0073 U	
P,P'-DDE	0.0033	8.9	17	MG/KG	<b>0.015</b>	<b>0.0036 J</b>	<b>0.0039 J</b>	
P,P'-DDT	0.0033	7.9	136	MG/KG	<b>0.0066 J</b>	<b>0.0052 J</b>	<b>0.0047 JP</b>	
Silvex (2,4,5-TP)	3.8	100	3.8	MG/KG	0.041 U	0.039 U	0.036 U	
Toxaphene	--	--	--	MG/KG	0.083 U	0.078 U	0.073 U	
trans-Chlordane	--	--	--	MG/KG	0.0083 U	0.0078 U	0.0073 U	

**Table 5. Summary of Remaining Pesticide and Herbicide Exceedances in Soil - 1221 Spofford Avenue, Bronx, New York**

					Sample Designation:	2B-EP-B-27	2B-EP-B-4
					Sample Date:	04/16/2020	05/15/2020
					Sample Depth (ft bls):	0 - 1	0 - 1
					Normal or Field Duplicate:	N	N
Parameter	NYSDEC Part 375 Unrestricted Use SCO	NYSDEC Part 375 Restricted Residential SCO	NYSDEC Part 375 Protection of Groundwater SCO	Unit			
2,4-D (Dichlorophenoxyacetic Acid)	--	--	--	MG/KG	0.041 U	0.035 U	
Acetic acid, (2,4,5-trichlorophenoxy)-	--	--	--	MG/KG	0.041 U	0.035 U	
Aldrin	0.005	0.097	0.19	MG/KG	0.0083 U	0.007 U	
Alpha Bhc (Alpha Hexachlorocyclohexane)	0.02	0.48	0.02	MG/KG	0.0025 U	0.0021 U	
Alpha Endosulfan	2.4	24	102	MG/KG	0.0083 U	0.007 U	
Beta Bhc (Beta Hexachlorocyclohexane)	0.036	0.36	0.09	MG/KG	0.0025 U	0.0021 U	
Beta Endosulfan	2.4	24	102	MG/KG	0.0083 U	0.007 U	
Chlordane	--	--	--	MG/KG	NA	NA	
cis-Chlordane	0.094	4.2	2.9	MG/KG	0.0083 U	0.007 U	
Delta BHC (Delta Hexachlorocyclohexane)	0.04	100	0.25	MG/KG	0.0025 U	0.0021 U	
Dieldrin	0.005	0.2	0.1	MG/KG	0.0025 U	0.0021 U	
Endosulfan Sulfate	2.4	24	1000	MG/KG	0.0083 U	0.007 U	
Endrin	0.014	11	0.06	MG/KG	0.0083 U	0.007 U	
Endrin Aldehyde	--	--	--	MG/KG	0.0083 U	0.007 U	
Endrin Ketone	--	--	--	MG/KG	0.0083 U	0.007 U	
Gamma Bhc (Lindane)	0.1	1.3	0.1	MG/KG	0.0025 U	0.0021 U	
Heptachlor	0.042	2.1	0.38	MG/KG	0.0083 U	0.007 U	
Heptachlor Epoxide	--	--	--	MG/KG	0.0083 U	0.007 U	
Methoxychlor	--	--	--	MG/KG	0.0083 U	0.007 U	
P,P'-DDD	0.0033	13	14	MG/KG	0.0083 U	0.007 U	
P,P'-DDE	0.0033	8.9	17	MG/KG	0.0083 U	0.0032 J	
P,P'-DDT	0.0033	7.9	136	MG/KG	<b>0.0053 J</b>	<b>0.0053 J</b>	
Silvex (2,4,5-TP)	3.8	100	3.8	MG/KG	0.041 U	0.035 U	
Toxaphene	--	--	--	MG/KG	0.083 U	0.07 U	
trans-Chlordane	--	--	--	MG/KG	0.0083 U	0.007 U	

**FIGURES**

1. Site Location Map
2. Site Layout Map
3. Generalized Hydrogeologic Cross Sections A-A`  
and B-B`
4. Groundwater Contour Map
5. Exceedances of Applicable Soil Cleanup Objectives
6. Monitoring Well Network

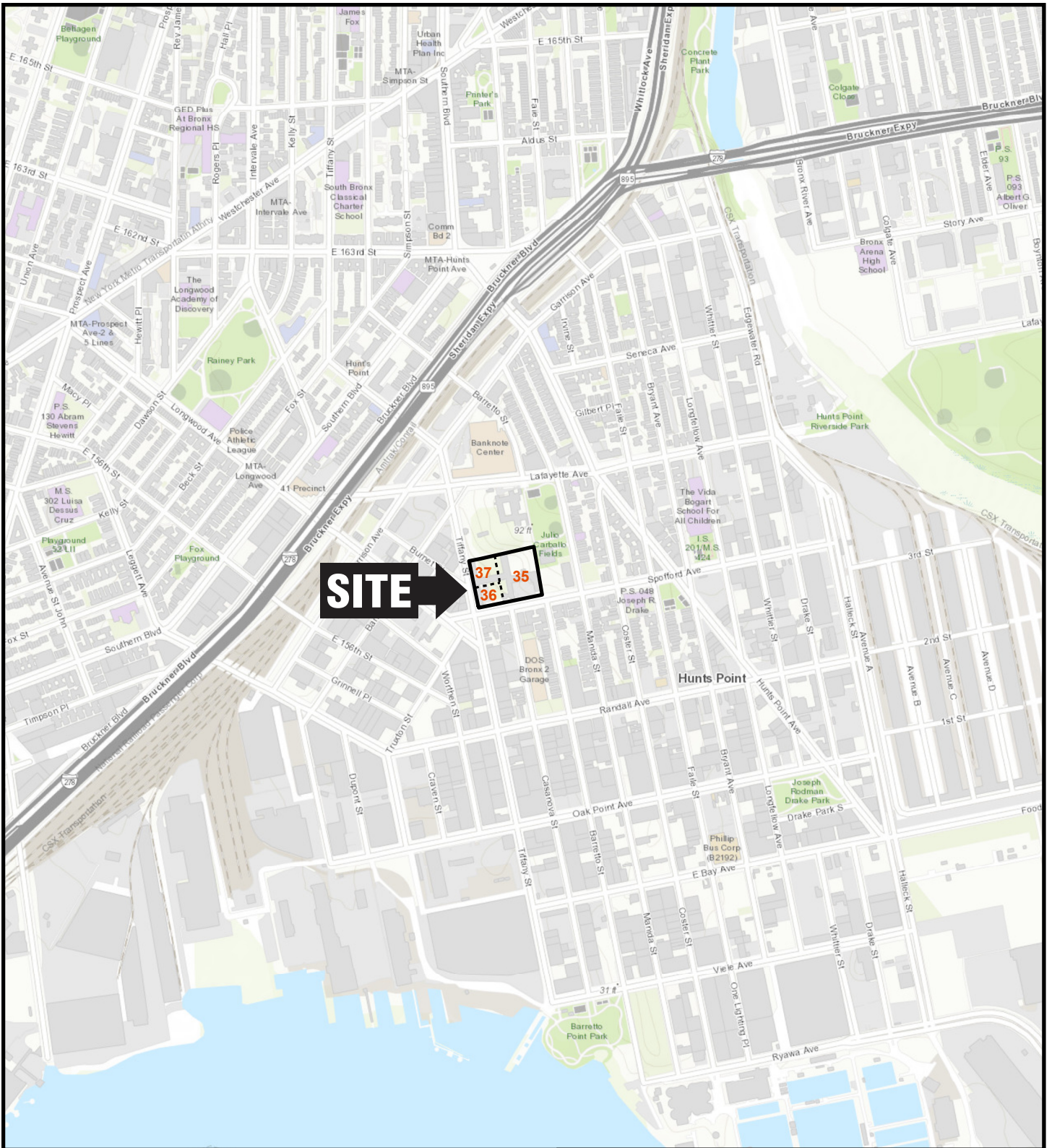

**SITE** →

37  
36  
35

**Hunts Point**

**QUADRANGLE LOCATION**



Title:

**SITE LOCATION MAP**

SITE MANAGEMENT PLAN  
BLOCK 2738, LOTS 35, 36, AND 37  
1221 SPOFFORD AVENUE, BRONX, NY

Prepared for:

THE PENINSULA JV, LLC



Compiled by: P.R.	Date: 07/06/20
Prepared by: M.S.R.	Scale: AS SHOWN
Project Mgr: LD.	Project: 2611.0002Y000
File: 2611.0002Y173.1.mxd	

FIGURE

**1**

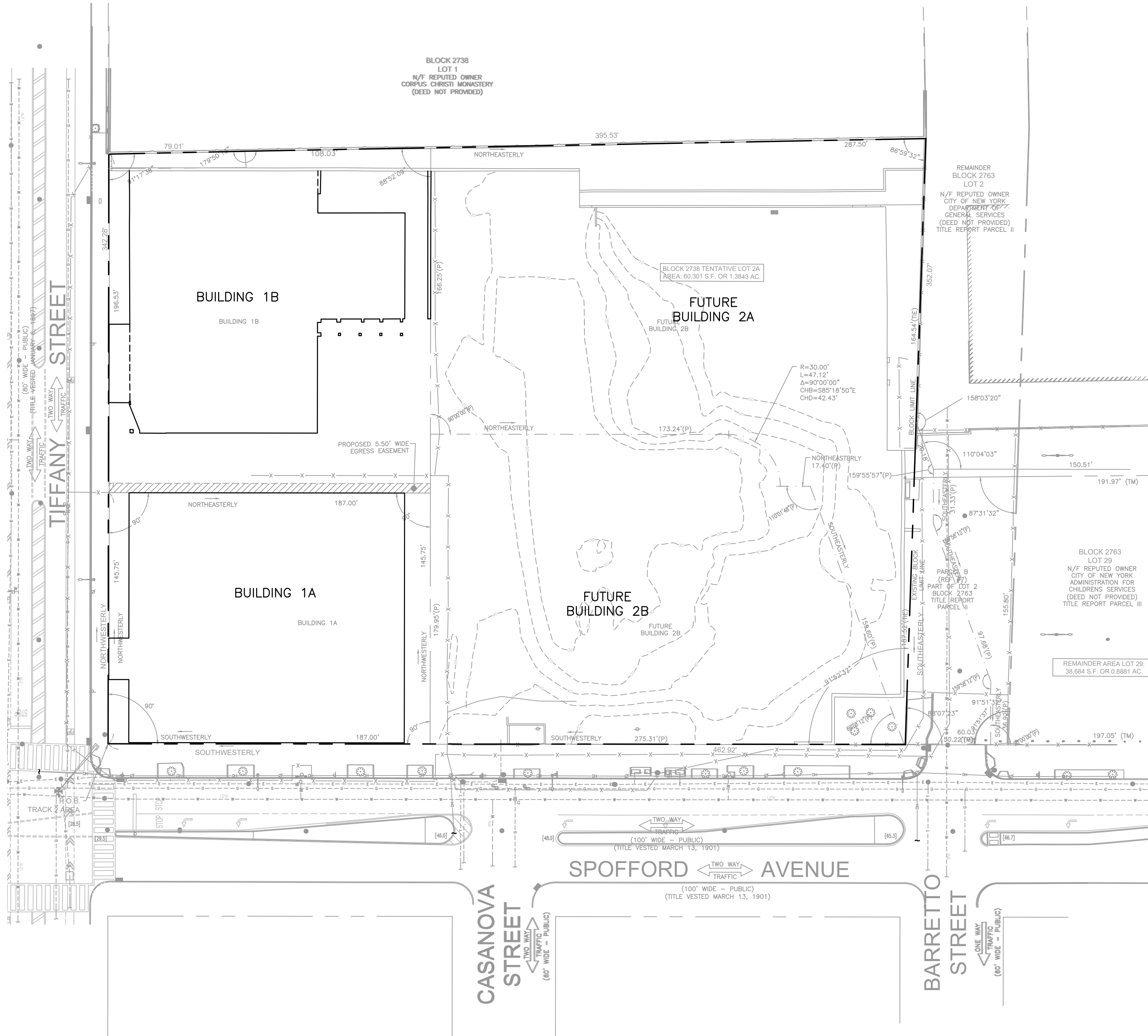

**LEGEND**

--- SITE BOUNDARY

**NOTES**

1. APPROXIMATE ELEVATION CONTOUR LINES AT FUTURE BUILDING 2A AND FUTURE BUILDING 2B GENERATED FROM SURVEY COMPLETED BY GALLAS SURVEYING GROUP ON JUNE 10, 2020.

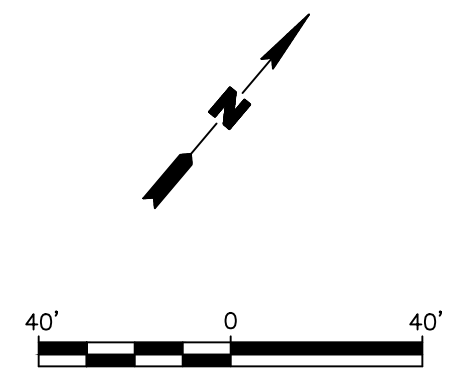

Title:			
<b>SITE LAYOUT MAP</b>			
SITE MANAGEMENT PLAN 1221 SPOFFORD AVENUE, BRONX, NEW YORK			
Prepared For:			
THE PENNINSULA JV, LLC			
Compiled by: P.R.	Date: 11SEPT20	<b>FIGURE</b> <b>2</b>	
Prepared by: G.M.	Scale: AS SHOWN		
Project Mgr: L.D.	Project: 2611.0002Y000		
File: 2611.0002Y173.05.DWG			

V:\CAD\PROJECTS\2611\0002Y173\2611.0002Y173.05.DWG



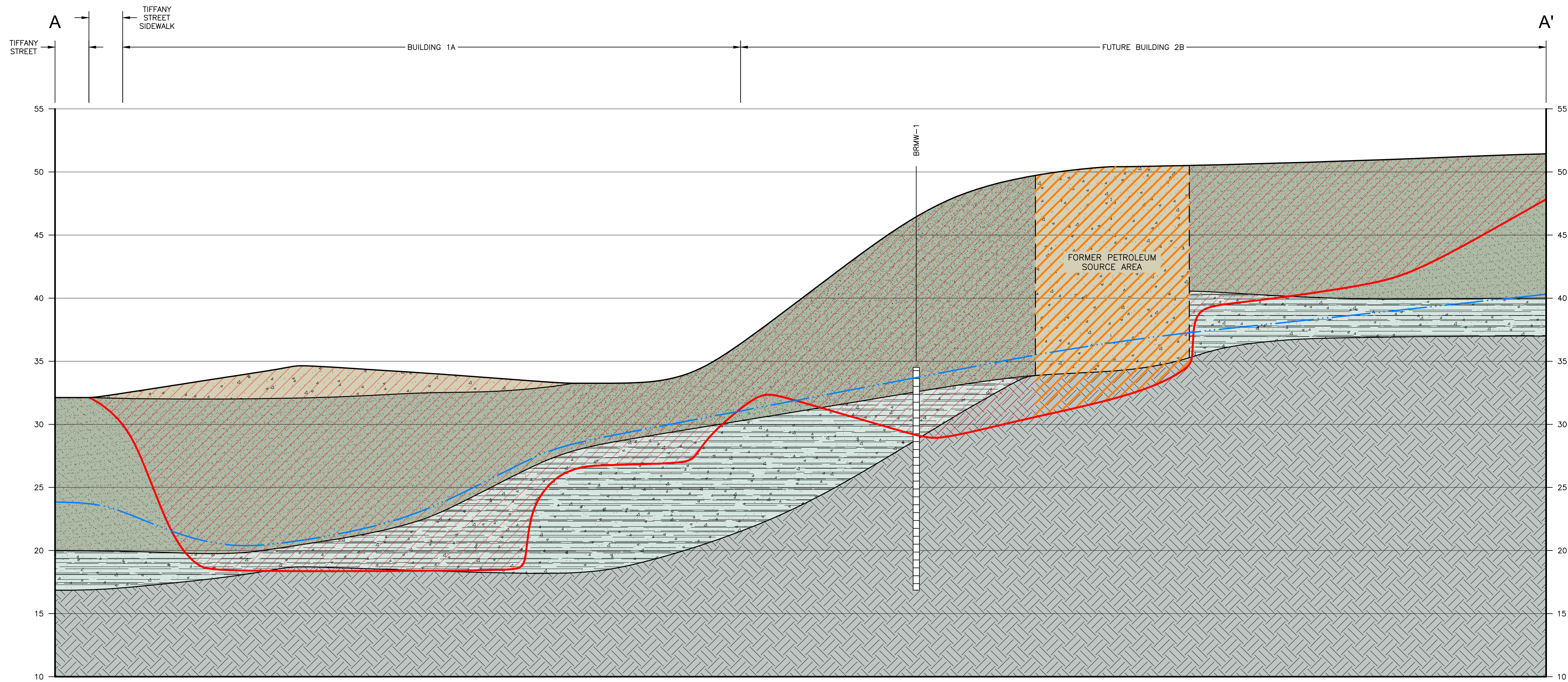

HORIZONTAL SCALE: 1" = 10'  
 VERTICAL SCALE: 1" = 5'  
 (VERTICAL EXAGGERATION 2X)

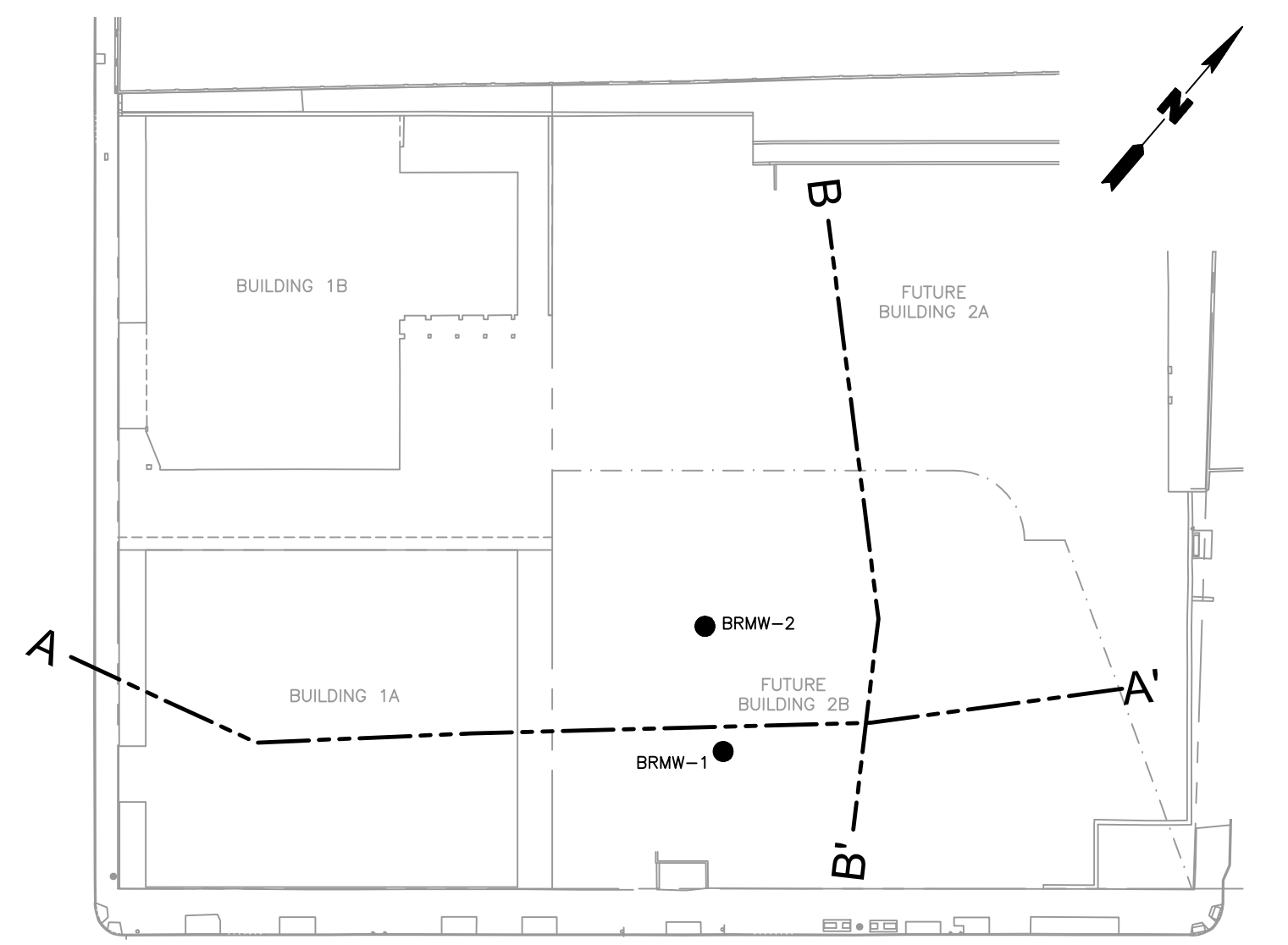

**LEGEND**

- FILL MATERIAL CONSISTING OF VARYING AMOUNTS OF SAND, SILT GRAVEL, COBBLE AND BRICK
- PRIMARY SAND AND SILT WITH VARYING AMOUNTS OF GRAVEL AND COBBLE
- WEATHERED BEDROCK WITH VARYING AMOUNTS OF SAND AND SILT
- BEDROCK (SCHIST AND GRANITE)
- APPROXIMATE EXTENT OF EXCAVATION
- APPROXIMATE EXTENT OF FORMER PETROLEUM SOURCE AREA EXCAVATION
- POTENTIOMETRIC SURFACE, JUNE 22, 2018
- LAND SURFACE
- SCREENED INTERVAL

**NOTE**

1. NAVD88 - NORTH AMERICAN VERTICAL DATUM OF 1988.
2. GROUNDWATER ELEVATION DATA FROM JUNE 22, 2018 GAUGING EVENT, COMPLETED DURING THE REMEDIAL INVESTIGATION.
3. LOCATIONS OF BRMW-1 AND BRMW-2 ARE APPROXIMATE.

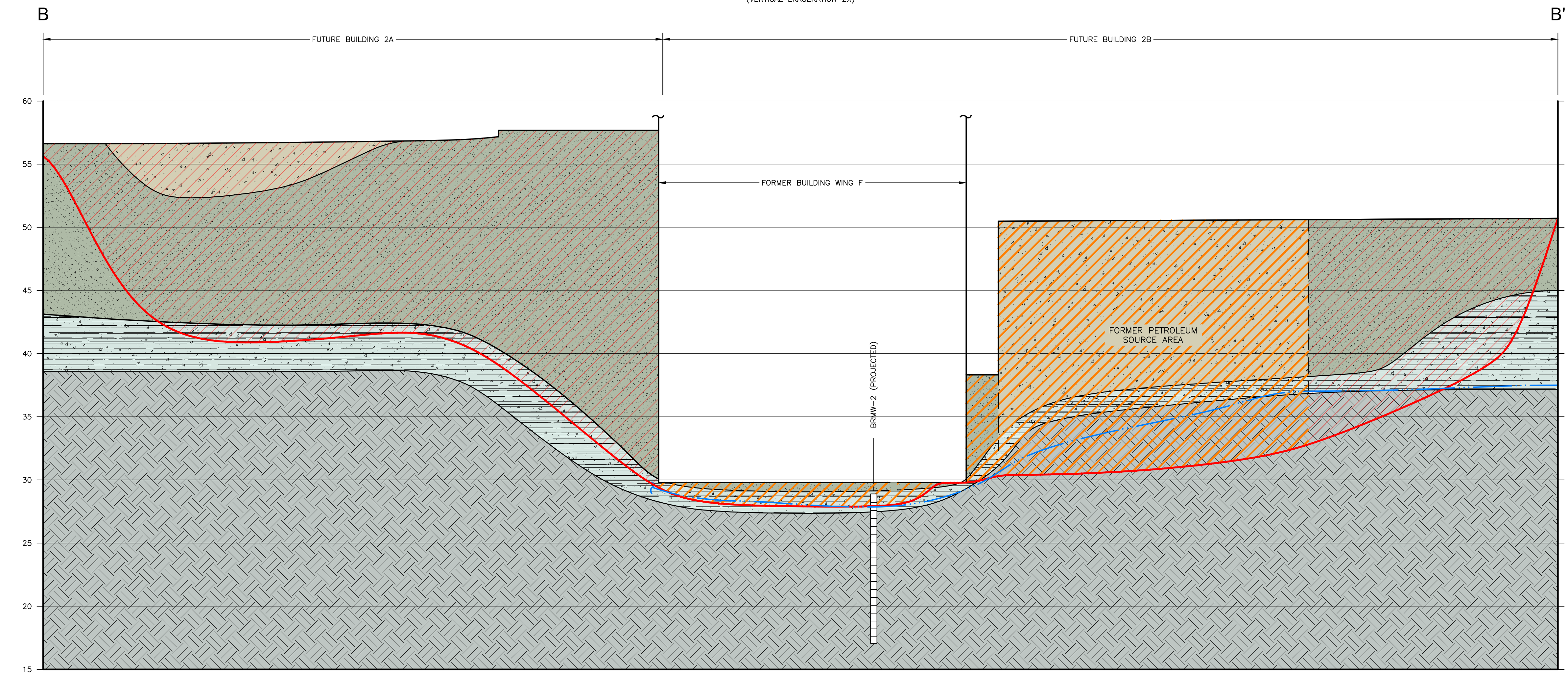

HORIZONTAL SCALE: 1" = 10'  
 VERTICAL SCALE: 1" = 5'  
 (VERTICAL EXAGGERATION 2X)

<b>GENERALIZED HYDROGEOLOGIC CROSS SECTIONS A-A' AND B-B'</b>			
SITE MANAGEMENT PLAN 1221 SPOFFORD AVENUE, BRONX, NEW YORK			
Prepared for: <b>THE PENINSULA JV, LLC</b>			
	Compiled by: P.R.	Date: 15OCT20	FIGURE <b>3</b>
	Prepared by: G.M.	Scale: AS SHOWN	
	Project Mgr: L.D.	Project: 2611.0002Y000	
	File: 2611.0002Y173.03.DWG		

V:\CADD\PROJECTS\2611\173\2611\_0002Y173\_03.DWG

V:\CAD\PROJECTS\2611Y\0002Y\173\2611\_0002Y\173.01.DWG

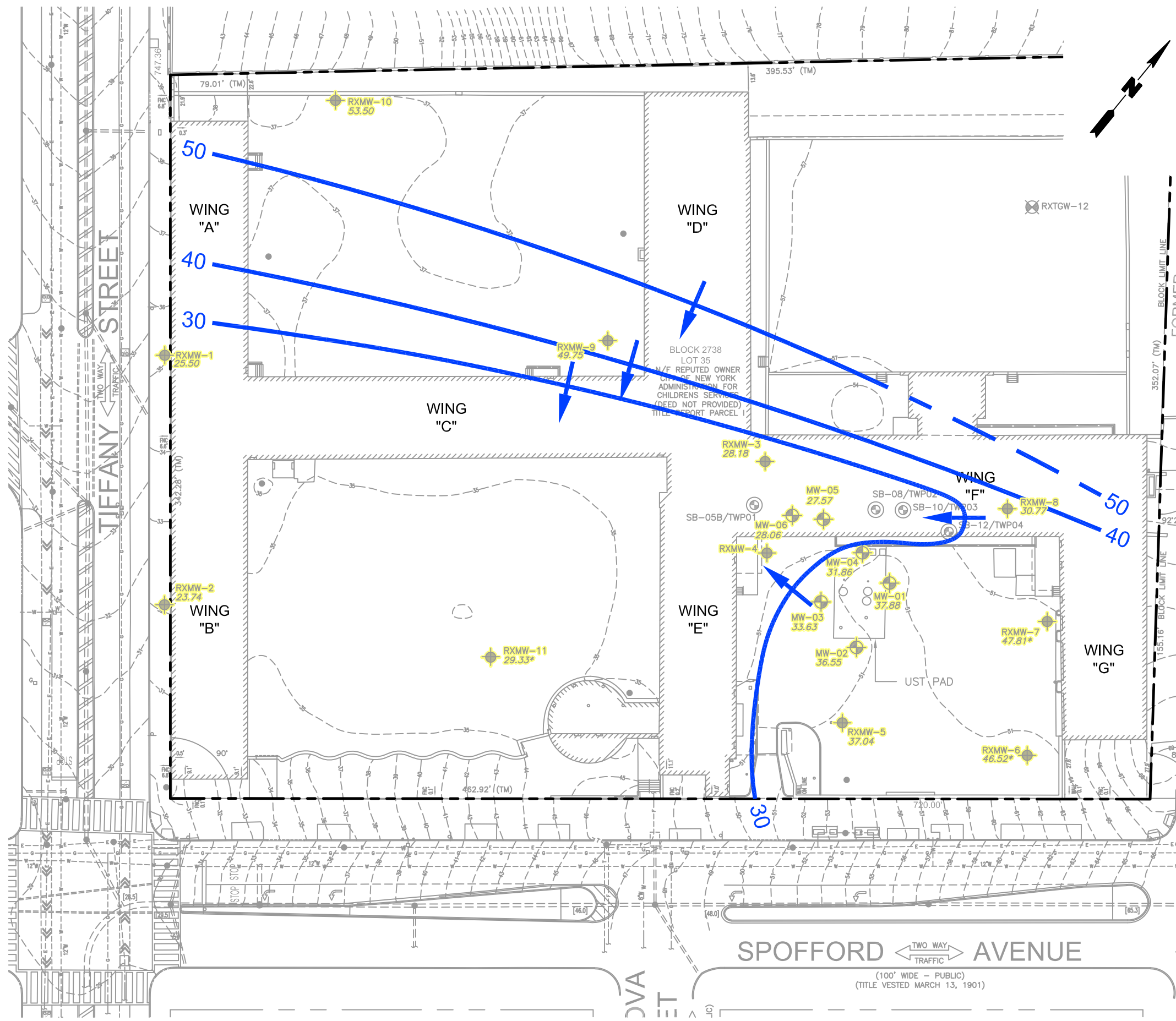

LEGEND

- SITE BOUNDARY
- SOIL BORING AND GROUNDWATER WELL LOCATION AND DESIGNATION INSTALLED BY ROUX DURING THE 2018 REMEDIAL INVESTIGATION
- SOIL BORING AND TEMPORARY GROUNDWATER WELL LOCATION (OVERBURDEN) INSTALLED BY ROUX DURING THE 2018 REMEDIAL INVESTIGATION
- MONITORING WELL GAUGED ON JUNE 22, 2018
- MONITORING WELL GAUGED ON JUNE 22, 2018
- COLOCATED SOIL BORING AND TEMPORARY WELL LOCATION AND DESIGNATION FROM URS 2009 INVESTIGATION
- MONITORING WELL LOCATION AND DESIGNATION INSTALLED BY LOUIS BERGER AND ASSOC., P.C., 2014
- GROUNDWATER ELEVATION (FEET RELATIVE TO NAVD 88)
- 40 GROUNDWATER CONTOUR ELEVATION (FEET RELATIVE TO NAVD 88) (DASHED WHERE INFERRED)
- GROUNDWATER FLOW DIRECTION
- \* GROUNDWATER ELEVATION NOT USED IN CONSTRUCTION OF CONTOUR

NOTES

1. NAVD88 - NORTH AMERICAN VERTICAL DATUM OF 1988.
2. GROUNDWATER ELEVATION DATA FROM JUNE 22, 2018 GAUGING EVENT, COMPLETED DURING THE REMEDIAL INVESTIGATION.

<p>Title: <b>GROUNDWATER CONTOUR MAP</b> <b>JUNE 22, 2018</b></p>		
<p>SITE MANAGEMENT REPORT 1221 SPOFFORD AVENUE, BRONX, NEW YORK</p>		
<p>Prepared for: <b>THE PENINSULA JV, LLC</b></p>		
<p>Compiled by: P.R.</p>	<p>Date: 15OCT20</p>	<p>FIGURE <b>4</b></p>
<p>Prepared by: G.M.</p>	<p>Scale: AS SHOWN</p>	
<p>Project Mgr: L.D.</p>	<p>Project: 2611.0002Y000</p>	
<p>File: 2611.0002Y173.01.DWG</p>		



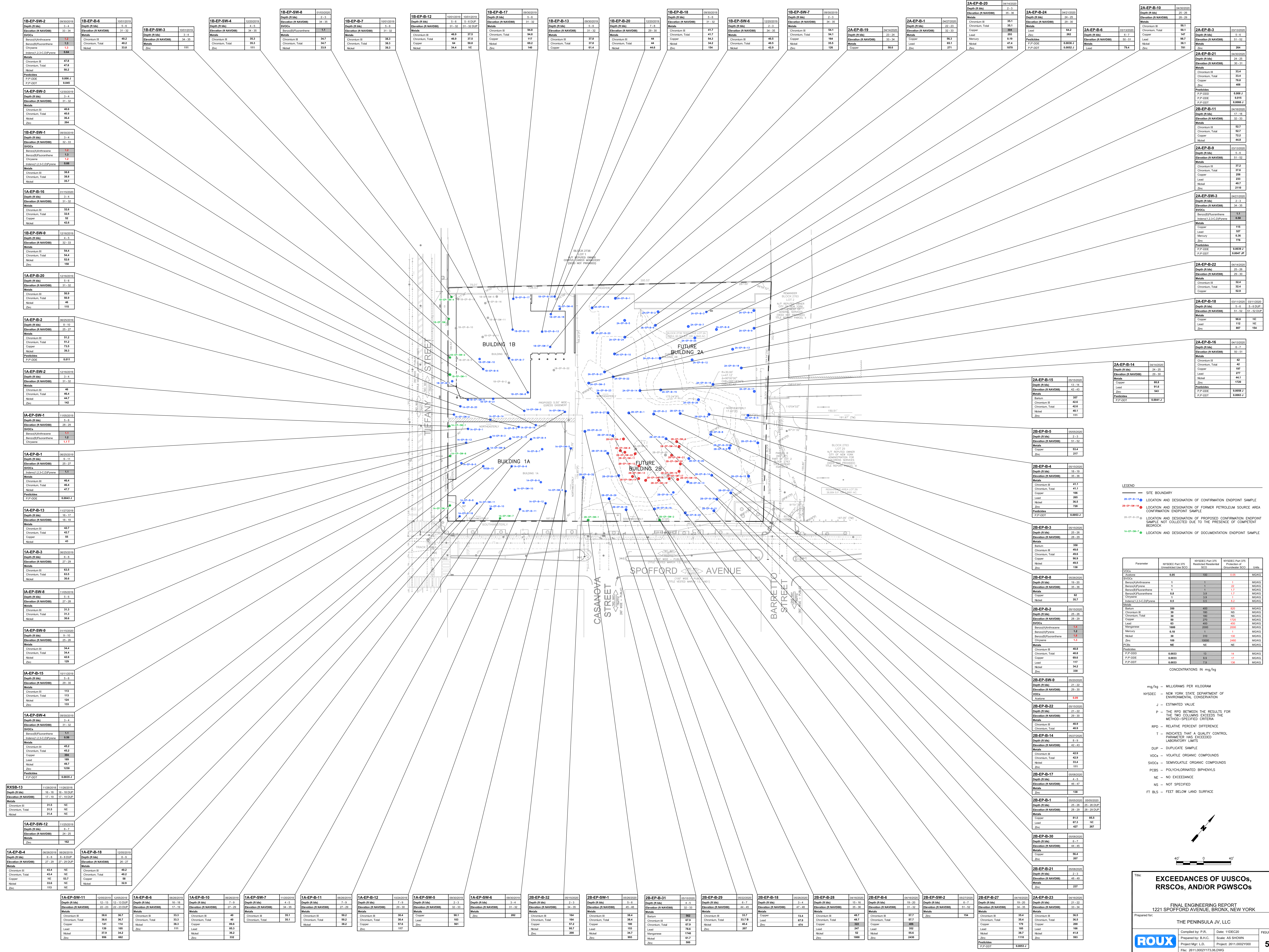

<b>1B-EP-SW-2</b> Depth (ft bbl): 3-4 Elevation (ft NAVD85): 33-34 SVOCs: Benz[a]Anthracene 1.5 Benz[b]Fluoranthene 1.8 Chrysene 1.3 IHDio[2,3-c]Pyrone 0.96 Metals: Chromium II 47.8 Chromium Total 47.8 Lead 50.2 Nickel 1.6 Pesticides: P,P'-DDE 0.004 J P,P'-DDT 0.005 J	<b>1B-EP-B-6</b> Depth (ft bbl): 3-4 Elevation (ft NAVD85): 31-32 Metals: Chromium II 46.2 Chromium Total 46.2 Nickel 33.8	<b>1B-EP-SW-3</b> Depth (ft bbl): 3-4 Elevation (ft NAVD85): 31-32 Metals: Chromium II 34.4 Chromium Total 34.7 Nickel 111	<b>1B-EP-SW-4</b> Depth (ft bbl): 3-4 Elevation (ft NAVD85): 31-32 Metals: Chromium II 34.7 Chromium Total 34.8 Nickel 111	<b>1B-EP-SW-8</b> Depth (ft bbl): 2-3 Elevation (ft NAVD85): 30-30 Metals: Chromium II 34.7 Chromium Total 34.7 Nickel 33.9	<b>1B-EP-B-7</b> Depth (ft bbl): 5-6 Elevation (ft NAVD85): 31-32 Metals: Chromium II 38.3 Chromium Total 38.3 Nickel 99.3	<b>1B-EP-B-12</b> Depth (ft bbl): 5-6 Elevation (ft NAVD85): 31-32 Metals: Chromium II 46.9 Chromium Total 46.9 Nickel 34.4 NE	<b>1B-EP-B-17</b> Depth (ft bbl): 5-6 Elevation (ft NAVD85): 31-32 Metals: Chromium II 34.8 Chromium Total 34.8 Nickel 148	<b>1B-EP-B-13</b> Depth (ft bbl): 3-4 Elevation (ft NAVD85): 31-32 Metals: Chromium II 37.8 Chromium Total 37.8 Nickel 61.4	<b>1B-EP-B-20</b> Depth (ft bbl): 2-3 Elevation (ft NAVD85): 29-30 Metals: Chromium II 44 Chromium Total 44 Nickel 44.6	<b>1B-EP-B-18</b> Depth (ft bbl): 5-6 Elevation (ft NAVD85): 31-32 Metals: Chromium II 41.2 Chromium Total 41.2 Nickel 154	<b>1B-EP-SW-6</b> Depth (ft bbl): 2-3 Elevation (ft NAVD85): 31-32 Metals: Chromium II 34-38 Chromium Total 46.9 Nickel 48.9	<b>1B-EP-SW-7</b> Depth (ft bbl): 2-3 Elevation (ft NAVD85): 31-32 Metals: Chromium II 54.1 Chromium Total 54.1 Nickel 126	<b>2A-EP-B-19</b> Depth (ft bbl): 2-3 Elevation (ft NAVD85): 31-32 Metals: Chromium II 40.8 Chromium Total 40.8 Nickel 98.6	<b>2A-EP-B-1</b> Depth (ft bbl): 2-3 Elevation (ft NAVD85): 31-32 Metals: Chromium II 65.1 Chromium Total 65.1 Nickel 271	<b>2A-EP-B-20</b> Depth (ft bbl): 2-3 Elevation (ft NAVD85): 31-32 Metals: Chromium II 65.1 Chromium Total 65.1 Nickel 1679	<b>2A-EP-B-24</b> Depth (ft bbl): 2-3 Elevation (ft NAVD85): 31-32 Metals: Chromium II 38.3 Chromium Total 38.3 Nickel 398	<b>2A-EP-B-5</b> Depth (ft bbl): 2-3 Elevation (ft NAVD85): 31-32 Metals: Chromium II 50-51 Chromium Total 50-51 Nickel 79.4	<b>2A-EP-B-10</b> Depth (ft bbl): 2-3 Elevation (ft NAVD85): 31-32 Metals: Chromium II 81 Chromium Total 81 Nickel 791	<b>2A-EP-B-3</b> Depth (ft bbl): 2-3 Elevation (ft NAVD85): 31-32 Metals: Chromium II 50-51 Chromium Total 50-51 Nickel 264	<b>2A-EP-B-21</b> Depth (ft bbl): 2-3 Elevation (ft NAVD85): 31-32 Metals: Chromium II 35.4 Chromium Total 35.4 Nickel 438	<b>2A-EP-B-9</b> Depth (ft bbl): 2-3 Elevation (ft NAVD85): 31-32 Metals: Chromium II 32.2 Chromium Total 32.2 Nickel 44.8	<b>2A-EP-B-22</b> Depth (ft bbl): 2-3 Elevation (ft NAVD85): 31-32 Metals: Chromium II 32.2 Chromium Total 32.2 Nickel 219	<b>2A-EP-B-18</b> Depth (ft bbl): 2-3 Elevation (ft NAVD85): 31-32 Metals: Chromium II 32.2 Chromium Total 32.2 Nickel 154	<b>2A-EP-B-16</b> Depth (ft bbl): 2-3 Elevation (ft NAVD85): 31-32 Metals: Chromium II 42 Chromium Total 42 Nickel 1729	<b>2A-EP-B-15</b> Depth (ft bbl): 2-3 Elevation (ft NAVD85): 31-32 Metals: Chromium II 42 Chromium Total 42 Nickel 897	<b>2B-EP-B-5</b> Depth (ft bbl): 2-3 Elevation (ft NAVD85): 31-32 Metals: Chromium II 53.4 Chromium Total 53.4 Nickel 247	<b>2B-EP-B-4</b> Depth (ft bbl): 2-3 Elevation (ft NAVD85): 31-32 Metals: Chromium II 41.2 Chromium Total 41.2 Nickel 53.4	<b>2B-EP-B-3</b> Depth (ft bbl): 2-3 Elevation (ft NAVD85): 31-32 Metals: Chromium II 38.3 Chromium Total 38.3 Nickel 118	<b>2B-EP-B-8</b> Depth (ft bbl): 2-3 Elevation (ft NAVD85): 31-32 Metals: Chromium II 82 Chromium Total 82 Nickel 36.7	<b>2B-EP-B-2</b> Depth (ft bbl): 2-3 Elevation (ft NAVD85): 31-32 Metals: Chromium II 39 Chromium Total 39 Nickel 180	<b>2B-EP-B-17</b> Depth (ft bbl): 2-3 Elevation (ft NAVD85): 31-32 Metals: Chromium II 40.8 Chromium Total 40.8 Nickel 300	<b>2B-EP-B-1</b> Depth (ft bbl): 2-3 Elevation (ft NAVD85): 31-32 Metals: Chromium II 40.8 Chromium Total 40.8 Nickel 117	<b>2B-EP-B-30</b> Depth (ft bbl): 2-3 Elevation (ft NAVD85): 31-32 Metals: Chromium II 40.8 Chromium Total 40.8 Nickel 247	<b>2B-EP-B-21</b> Depth (ft bbl): 2-3 Elevation (ft NAVD85): 31-32 Metals: Chromium II 40.8 Chromium Total 40.8 Nickel 247	<b>2B-EP-B-14</b> Depth (ft bbl): 2-3 Elevation (ft NAVD85): 31-32 Metals: Chromium II 40.8 Chromium Total 40.8 Nickel 247	<b>2B-EP-B-22</b> Depth (ft bbl): 2-3 Elevation (ft NAVD85): 31-32 Metals: Chromium II 40.8 Chromium Total 40.8 Nickel 247	<b>2B-EP-B-15</b> Depth (ft bbl): 2-3 Elevation (ft NAVD85): 31-32 Metals: Chromium II 40.8 Chromium Total 40.8 Nickel 247	<b>2B-EP-B-1</b> Depth (ft bbl): 2-3 Elevation (ft NAVD85): 31-32 Metals: Chromium II 40.8 Chromium Total 40.8 Nickel 247	<b>2B-EP-B-1</b> Depth (ft bbl): 2-3 Elevation (ft NAVD85): 31-32 Metals: Chromium II 40.8 Chromium Total 40.8 Nickel 247	<b>2B-EP-B-1</b> Depth (ft bbl): 2-3 Elevation (ft NAVD85): 31-32 Metals: Chromium II 40.8 Chromium Total 40.8 Nickel 247	<b>2B-EP-B-1</b> Depth (ft bbl): 2-3 Elevation (ft NAVD85): 31-32 Metals: Chromium II 40.8 Chromium Total 40.8 Nickel 247	<b>2B-EP-B-1</b> Depth (ft bbl): 2-3 Elevation (ft NAVD85): 31-32 Metals: Chromium II 40.8 Chromium Total 40.8 Nickel 247	<b>2B-EP-B-1</b> Depth (ft bbl): 2-3 Elevation (ft NAVD85): 31-32 Metals: Chromium II 40.8 Chromium Total 40.8 Nickel 247	<b>2B-EP-B-1</b> Depth (ft bbl): 2-3 Elevation (ft NAVD85): 31-32 Metals: Chromium II 40.8 Chromium Total 40.8 Nickel 247
---	--	--	--	---	--	--	--	---	---	--	--	--	---	---	---	--	--	--	---	--	--	--	--	---	--	---	--	---	--	---	--	---	--	--	--	--	--	---	---	---	---	---	---	---

**LEGEND**

- SITE BOUNDARY
- LOCATION AND DESIGNATION OF FORMER PETROLEUM SOURCE AREA CONFIRMATION ENDPOINT SAMPLE
- LOCATION AND DESIGNATION OF PROPOSED CONFIRMATION ENDPOINT SAMPLE NOT COLLECTED DUE TO THE PRESENCE OF COMPETENT BEDROCK
- LOCATION AND DESIGNATION OF DOCUMENTATION ENDPOINT SAMPLE

Parameter	NYSDC Part 373 Universal Limit SCO	NYSDC Part 375 Universal Limit SCO	NYSDC Part 375 Groundwater SCO	Units
<b>1A-EP-B-1</b>	100	100	100	µg/kg
<b>1A-EP-B-2</b>	100	100	100	µg/kg
<b>1A-EP-B-3</b>	100	100	100	µg/kg
<b>1A-EP-B-4</b>	100	100	100	µg/kg
<b>1A-EP-B-5</b>	100	100	100	µg/kg
<b>1A-EP-B-6</b>	100	100	100	µg/kg
<b>1A-EP-B-7</b>	100	100	100	µg/kg
<b>1A-EP-B-8</b>	100	100	100	µg/kg
<b>1A-EP-B-9</b>	100	100	100	µg/kg
<b>1A-EP-B-10</b>	100	100	100	µg/kg
<b>1A-EP-B-11</b>	100	100	100	µg/kg
<b>1A-EP-B-12</b>	100	100	100	µg/kg
<b>1A-EP-B-13</b>	100	100	100	µg/kg
<b>1A-EP-B-14</b>	100	100	100	µg/kg
<b>1A-EP-B-15</b>	100	100	100	µg/kg
<b>1A-EP-B-16</b>	100	100	100	µg/kg
<b>1A-EP-B-17</b>	100	100	100	µg/kg
<b>1A-EP-B-18</b>	100	100	100	µg/kg
<b>1A-EP-B-19</b>	100	100	100	µg/kg
<b>1A-EP-B-20</b>	100	100	100	µg/kg
<b>1A-EP-B-21</b>	100	100	100	µg/kg
<b>1A-EP-B-22</b>	100	100	100	µg/kg
<b>1A-EP-B-23</b>	100	100	100	µg/kg
<b>1A-EP-B-24</b>	100	100	100	µg/kg
<b>1A-EP-B-25</b>	100	100	100	µg/kg
<b>1A-EP-B-26</b>	100	100	100	µg/kg
<b>1A-EP-B-27</b>	100	100	100	µg/kg
<b>1A-EP-B-28</b>	100	100	100	µg/kg
<b>1A-EP-B-29</b>	100	100	100	µg/kg
<b>1A-EP-B-30</b>	100	100	100	µg/kg
<b>1A-EP-SW-1</b>	100	100	100	µg/kg
<b>1A-EP-SW-2</b>	100	100	100	µg/kg
<b>1A-EP-SW-3</b>	100	100	100	µg/kg
<b>1A-EP-SW-4</b>	100	100	100	µg/kg
<b>1A-EP-SW-5</b>	100	100	100	µg/kg
<b>1A-EP-SW-6</b>	100	100	100	µg/kg
<b>1A-EP-SW-7</b>	100	100	100	µg/kg
<b>1A-EP-SW-8</b>	100	100	100	µg/kg
<b>1A-EP-SW-9</b>	100	100	100	µg/kg
<b>1A-EP-SW-10</b>	100	100	100	µg/kg
<b>1A-EP-SW-11</b>	100	100	100	µg/kg
<b>1A-EP-SW-12</b>	100	100	100	µg/kg
<b>1A-EP-SW-13</b>	100	100	100	µg/kg
<b>1A-EP-SW-14</b>	100	100	100	µg/kg
<b>1A-EP-SW-15</b>	100	100	100	µg/kg
<b>1A-EP-SW-16</b>	100	100	100	µg/kg
<b>1A-EP-SW-17</b>	100	100	100	µg/kg
<b>1A-EP-SW-18</b>	100	100	100	µg/kg
<b>1A-EP-SW-19</b>	100	100	100	µg/kg
<b>1A-EP-SW-20</b>	100	100	100	µg/kg
<b>1A-EP-SW-21</b>	100	100	100	µg/kg
<b>1A-EP-SW-22</b>	100	100	100	µg/kg
<b>1A-EP-SW-23</b>	100	100	100	µg/kg
<b>1A-EP-SW-24</b>	100	100	100	µg/kg
<b>1A-EP-SW-25</b>	100	100	100	µg/kg
<b>1A-EP-SW-26</b>	100	100	100	µg/kg
<b>1A-EP-SW-27</b>	100	100	100	µg/kg
<b>1A-EP-SW-28</b>	100	100	100	µg/kg
<b>1A-EP-SW-29</b>	100	100	100	µg/kg
<b>1A-EP-SW-30</b>	100	100	100	µg/kg
<b>2B-EP-SW-1</b>	100	100	100	µg/kg
<b>2B-EP-SW-2</b>	100	100	100	µg/kg
<b>2B-EP-SW-3</b>	100	100	100	µg/kg
<b>2B-EP-SW-4</b>	100	100	100	µg/kg
<b>2B-EP-SW-5</b>	100	100	100	µg/kg
<b>2B-EP-SW-6</b>	100	100	100	µg/kg
<b>2B-EP-SW-7</b>	100	100	100	µg/kg
<b>2B-EP-SW-8</b>	100	100	100	µg/kg
<b>2B-EP-SW-9</b>	100	100	100	µg/kg
<b>2B-EP-SW-10</b>	100	100	100	µg/kg
<b>2B-EP-SW-11</b>	100	100	100	µg/kg
<b>2B-EP-SW-12</b>	100	100	100	µg/kg
<b>2B-EP-SW-13</b>	100	100	100	µg/kg
<b>2B-EP-SW-14</b>	100	100	100	µg/kg
<b>2B-EP-SW-15</b>	100	100	100	µg/kg
<b>2B-EP-SW-16</b>	100	100	100	µg/kg
<b>2B-EP-SW-17</b>	100	100	100	µg/kg
<b>2B-EP-SW-18</b>	100	100	100	µg/kg
<b>2B-EP-SW-19</b>	100	100	100	µg/kg
<b>2B-EP-SW-20</b>	100	100	100	µg/kg
<b>2B-EP-SW-21</b>	100	100	100	µg/kg
<b>2B-EP-SW-22</b>	100	100	100	µg/kg
<b>2B-EP-SW-23</b>	100	100	100	µg/kg
<b>2B-EP-SW-24</b>	100	100	100	µg/kg
<b>2B-EP-SW-25</b>	100	100	100	µg/kg
<b>2B-EP-SW-26</b>	100	100	100	µg/kg
<b>2B-EP-SW-27</b>	100	100	100	µg/kg
<b>2B-EP-SW-28</b>	100	100	100	µg/kg
<b>2B-EP-SW-29</b>	100	100	100	µg/kg
<b>2B-EP-SW-30</b>	100	100	100	µg/kg

**CONCENTRATIONS IN mg/kg**

mg/kg - MILLIGRAMS PER KILOGRAM

NYSDC - NEW YORK STATE DEPARTMENT OF ENVIRONMENTAL CONSERVATION

J - ESTIMATED VALUE

† - THE RFD BETWEEN THE RESULTS FOR THE TWO COLUMNS EXCEEDS THE METHOD-SPECIFIED CRITERIA

RPD - RELATIVE PERCENT DIFFERENCE

T - INDICATES THAT A QUALITY CONTROL PARAMETER HAS EXCEEDED LABORATORY LIMITS

DUP - DUPLICATE SAMPLE

VOCS - VOLATILE ORGANIC COMPOUNDS

SVOCs - SEMI-VOLATILE ORGANIC COMPOUNDS

PCB's - POLYCHLORINATED BIIPHENYLS

NE - NO EXCEEDANCE

NS - NOT SPECIFIED

FT BLS - FEET BELOW LAND SURFACE

**EXCEEDANCES OF UUSCOs, RRRSCOs, AND/OR PGWSCOs**

FINAL ENGINEERING REPORT  
1221 SPOFFORD AVENUE, BRONX, NEW YORK

Prepared for: THE PENINSULA JV, LLC

Prepared by: R.I.C. Date: 11/20/2019  
Project Mgr. L.D. Project: 2011.0021000

ROUX  
900  
2408

FIGURE 5

VA-CAD\PROJECTS\2611\0002\173\2611.0002\173.04.DWG

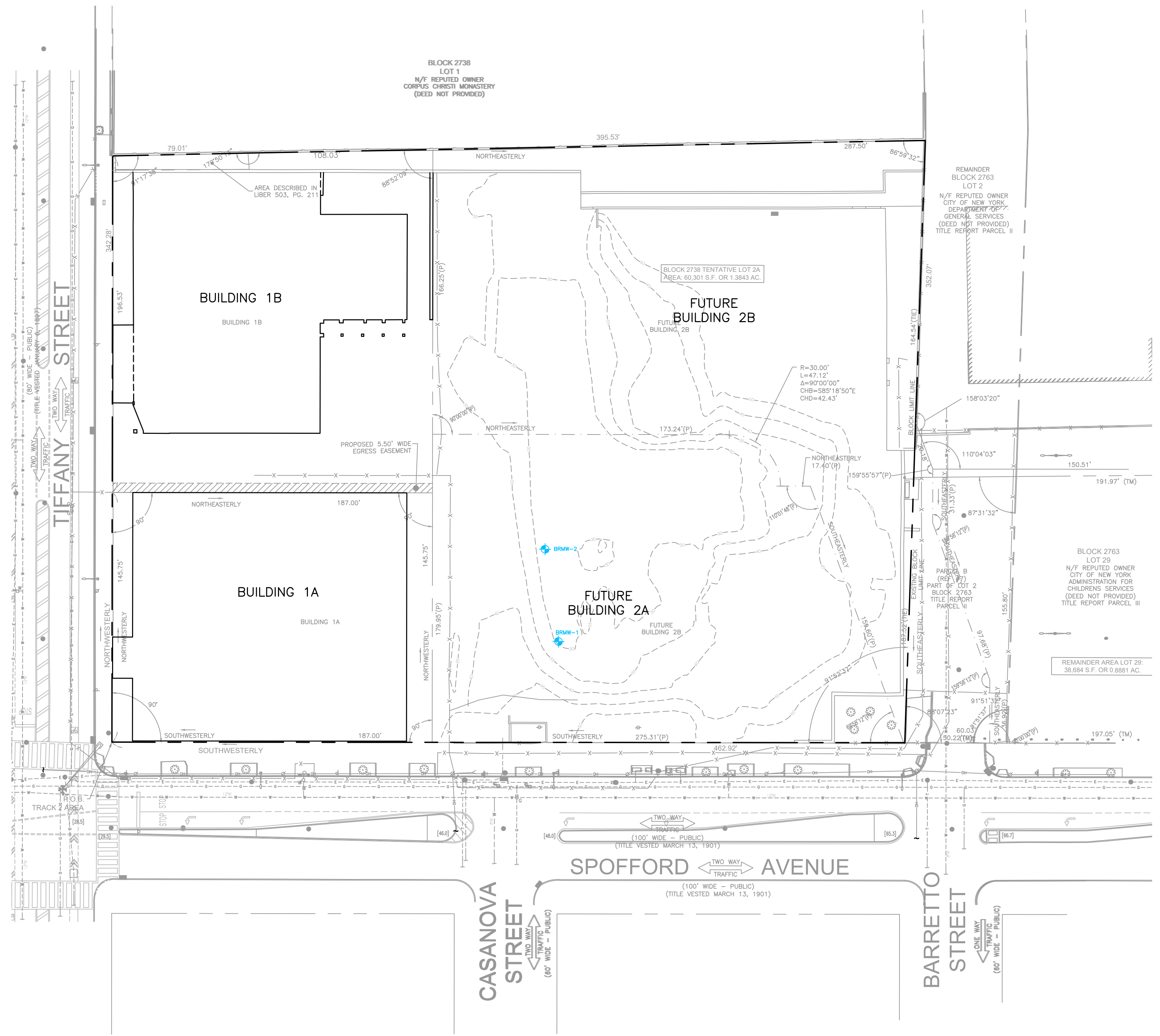

**LEGEND**

— SITE BOUNDARY

BRMW-1 DESIGNATION AND APPROXIMATE LOCATION OF BEDROCK MONITORING WELL

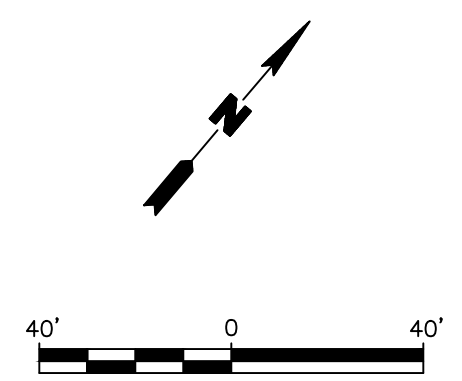

Title:			
<b>MONITORING WELL NETWORK</b>			
SITE MANAGEMENT PLAN 1221 SPOFFORD AVENUE, BRONX, NEW YORK			
Prepared For:			
THE PENINSULA JV, LLC			
Compiled by: P.R.	Date: 24JUN20	<b>FIGURE</b> <b>6</b>	
Prepared by: G.M.	Scale: AS SHOWN		
Project Mgr: L.D.	Project: 2611.0002Y000		
File: 2611.0002Y173.04.DWG			

**APPENDICES**

- A. Environmental Easement
- B. List of Site Contacts
- C. Responsibilities of Owner and Remedial Party
- D. Site Specific Boring Logs
- E. Monitoring Well Boring and Construction Logs
- F. Track 2 Determination Letter
- G. Excavation Work Plan
- H. Site-Specific Health and Safety Plan
- I. Site Management Forms
- J. Quality Assurance Project Plan/Field Sampling Plan

Environmental Easement

**NYC DEPARTMENT OF FINANCE  
OFFICE OF THE CITY REGISTER**

This page is part of the instrument. The City Register will rely on the information provided by you on this page for purposes of indexing this instrument. The information on this page will control for indexing purposes in the event of any conflict with the rest of the document.

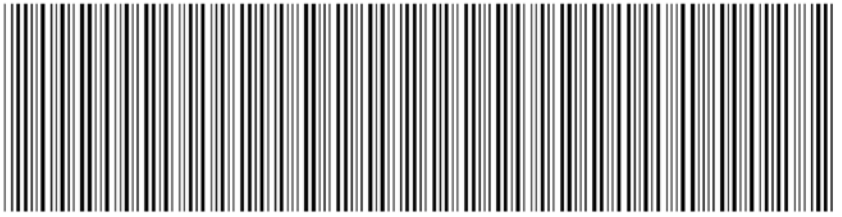

2020120800474001006E64DF

**RECORDING AND ENDORSEMENT COVER PAGE**

**PAGE 1 OF 15**

Document ID: 2020120800474001

Document Date: 12-01-2020

Preparation Date: 12-09-2020

Document Type: EASEMENT

Document Page Count: 13

**PRESENTER:**

CHICAGO TITLE INSURANCE CO. (PICK-UP)  
711 THIRD AVE, 5TH FLOOR  
CT20-80156-BX CB  
NEW YORK, NY 10017  
212-880-1200  
CTINYRECORDING@CTT.COM

**RETURN TO:**

HIRSHEN SINGER & EPSTEIN  
902 BROADWAY 13TH FLOOR  
FATMATA JALLOH  
NEW YORK, NY 10010

**PROPERTY DATA**

Borough	Block	Lot	Unit	Address
BRONX	2738	35	Entire Lot	1201 SPOFFORD AVENUE

**Property Type:** RESIDENTIAL VACANT LAND

Borough	Block	Lot	Unit	Address
BRONX	2738	36	Entire Lot	1215 SPOFFORD AVENUE

**Property Type:** COMMERCIAL REAL ESTATE

Additional Properties on Continuation Page

**CROSS REFERENCE DATA**

CRFN \_\_\_\_\_ or DocumentID \_\_\_\_\_ or \_\_\_\_\_ Year \_\_\_\_\_ Reel \_\_\_\_\_ Page \_\_\_\_\_ or File Number \_\_\_\_\_

**PARTIES**

**GRANTOR/SELLER:**

THE CITY OF NEW YORK  
CITY HALL  
NEW YORK, NY 10007-1602

**GRANTEE/BUYER:**

THE PEOPLE OF THE STATE OF NEW YORK  
ACTING THROUGH THEIR COMMISSIONER OF THE  
DEPT. OF ENVIRONMENTAL CONSERVATION, 625  
BROADWAY  
ALBANY, NY 12233-1500

Additional Parties Listed on Continuation Page

**FEES AND TAXES**

**Mortgage :**

Mortgage Amount:	\$	0.00
Taxable Mortgage Amount:	\$	0.00
Exemption:		
TAXES: County (Basic):	\$	0.00
City (Additional):	\$	0.00
Spec (Additional):	\$	0.00
TASF:	\$	0.00
MTA:	\$	0.00
NYCTA:	\$	0.00
Additional MRT:	\$	0.00
<b>TOTAL:</b>	<b>\$</b>	<b>0.00</b>
Recording Fee:	\$	108.00
Affidavit Fee:	\$	0.00

**Filing Fee:**

\$ 250.00

**NYC Real Property Transfer Tax:**

\$ 0.00

**NYS Real Estate Transfer Tax:**

\$ 0.00

**RECORDED OR FILED IN THE OFFICE  
OF THE CITY REGISTER OF THE**



**CITY OF NEW YORK**

Recorded/Filed 12-10-2020 13:17

City Register File No.(CRFN):

2020000351824

*Annette McHill*

City Register Official Signature

NYC DEPARTMENT OF FINANCE  
OFFICE OF THE CITY REGISTER

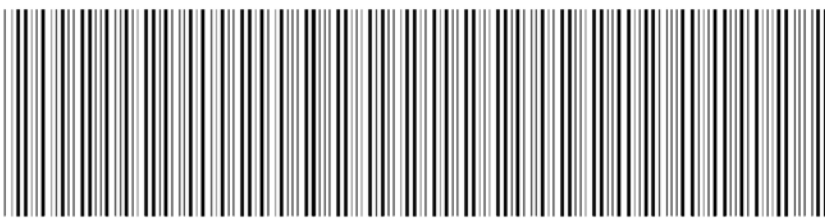

2020120800474001006C665F

**RECORDING AND ENDORSEMENT COVER PAGE (CONTINUATION)**

**PAGE 2 OF 15**

**Document ID: 2020120800474001**

Document Date: 12-01-2020

Preparation Date: 12-09-2020

Document Type: EASEMENT

**PROPERTY DATA**

<b>Borough</b>	<b>Block Lot</b>	<b>Unit</b>	<b>Address</b>
BRONX	2738 37 Entire Lot		720 TIFFANY STREET

**Property Type: COMMERCIAL REAL ESTATE**

**PARTIES**

**GRANTOR/SELLER:**

MHANY PENINSULA LOCAL DEVELOPMENT  
CORPORATION  
C/O: MHANY MANAGEMENT, INC., 470  
VANDERBILT AVENUE, 9TH FLOOR

**GRANTOR/SELLER:**

SPOFFORD 1B HOUSING DEVELOPMENT FUND  
CORPORATION  
C/O: MHANY MANAGEMENT, INC., 470  
VANDERBILT AVENUE, 9TH FLOOR

**GRANTOR/SELLER:**

PENINSULA BUILDING 1B LLC  
88 PINE STREET, 27TH FLOOR  
NEW YORK, NY 10005



**ENVIRONMENTAL EASEMENT GRANTED PURSUANT TO ARTICLE 71, TITLE 36  
OF THE NEW YORK STATE ENVIRONMENTAL CONSERVATION LAW**

THIS INDENTURE made <sup>as of</sup> this 1<sup>st</sup> day of December, 2020, between Owner, **The City of New York**, (the "Fee Owner), having an office at City Hall, New York, New York 10007-1602; **MHANY Peninsula Local Development Corporation**, a New York not-for-profit corporation, (the "LDC Leaseholder"), having an office at c/o MHANY Management, Inc., 470 Vanderbilt Ave 9th floor, Brooklyn, NY 11238, **Spofford 1B Housing Development Fund Corporation**, a New York not-for-profit corporation (the "HDFC Leaseholder"), having an office at c/o MHANY Management, Inc., 470 Vanderbilt Ave 9th floor, Brooklyn, NY 11238; and, **Peninsula Building 1B LLC**, a New York limited liability company (the "Beneficial Leaseholder"), having an office at c/o The Limited Liability Company, 88 Pine Street, 27th Floor, New York, New York 10005 (collectively the "Grantor"), and **The People of the State of New York** (the "Grantee."), acting through their Commissioner of the Department of Environmental Conservation (the "Commissioner", or "NYSDEC" or "Department" as the context requires) with its headquarters located at 625 Broadway, Albany, New York 12233,

**WHEREAS**, the Legislature of the State of New York has declared that it is in the public interest to encourage the remediation of abandoned and likely contaminated properties ("sites") that threaten the health and vitality of the communities they burden while at the same time ensuring the protection of public health and the environment; and

**WHEREAS**, the Legislature of the State of New York has declared that it is in the public interest to establish within the Department a statutory environmental remediation program that includes the use of Environmental Easements as an enforceable means of ensuring the performance of operation, maintenance, and/or monitoring requirements and the restriction of future uses of the land, when an environmental remediation project leaves residual contamination at levels that have been determined to be safe for a specific use, but not all uses, or which includes engineered structures that must be maintained or protected against damage to perform properly and be effective, or which requires groundwater use or soil management restrictions; and

**WHEREAS**, the Legislature of the State of New York has declared that Environmental Easement shall mean an interest in real property, created under and subject to the provisions of Article 71, Title 36 of the New York State Environmental Conservation Law ("ECL") which contains a use restriction and/or a prohibition on the use of land in a manner inconsistent with engineering controls which are intended to ensure the long term effectiveness of a site remedial program or eliminate potential exposure pathways to hazardous waste or petroleum; and

**WHEREAS**, Fee Owner, **The City of New York**, is the owner of real property located at the address of 1201 Spofford Avenue in the City of New York, County of Bronx and State of New York, known and designated on the tax map of the New York City Department of Finance as tax map parcel number: Block 2738 Lot 35, being a portion of the property conveyed to Grantor by deed dated December 11, 1961 and recorded in the County Clerk's Office in Liber and Page 1885/478;

**WHEREAS**, Fee Owner, **The City of New York**, is the owner of real property located at the address of 1215 Spofford Avenue in the City of New York, County of Bronx and State of New

York, known and designated on the tax map of the New York City Department of Finance as tax map parcel number: Block 2738 Lot 36, being a portion of the property conveyed to Grantor by Final Decree dated and May 4, 1953 in that condemnation matter filed by the City of New York in Bronx Supreme Court having an index number of 1338/1952;

**WHEREAS**, Fee Owner, **The City of New York**, is the owner of real property located at the address of 720 Tiffany Street in the City of New York, County of Bronx and State of New York, known and designated on the tax map of the New York City Department of Finance as tax map parcel number: Block 2738 Lot 37, being a portion of the property conveyed to Grantor by Final Decree dated and May 4, 1953 in that condemnation matter filed by the City of New York in Bronx Supreme Court having an index number of 1338/1952;

**WHEREAS**, the property subject to this Environmental Easement (the "Controlled Property") comprises approximately 3.7348 +/- acres, and is hereinafter more fully described in the Land Title Survey dated May 1, 2020 prepared by Gregory S. Gallas, L.L.S. of Gallas Surveying Group, which will be attached to the Site Management Plan. The Controlled Property description is set forth in and attached hereto as Schedule A;

**WHEREAS**, LDC Leaseholder, **MHANY Peninsula Local Development Corporation**, is the tenant of Block 2738, Lot 36 pursuant to a 49-year lease dated May 22, 2019 and referenced in that Memorandum of Lease dated May 22, 2019 and recorded in City Register of the City of New York as CRFN # 2019000173184;

**WHEREAS**, Beneficial Leaseholder, **Peninsula Building 1B LLC**, as the beneficial and equitable interest holder of the lease in which legal title is held by HDFC Leaseholder, **Spofford 1B Housing Development Fund Corporation**, as nominee (pursuant to that certain Declaration of Interest and Nominee Agreement, dated June 27, 2019 and recorded in the City Register of the City of New York as CRFN# 2019000222470) is the tenant of Block 2738, Lot 37 pursuant to a 65-year lease dated June 27, 2019 and referenced in that Memorandum of Lease dated June 27, 2019 and recorded in City Register of the City of New York as CRFN # 2019000222468; and

**WHEREAS**, the Department accepts this Environmental Easement in order to ensure the protection of public health and the environment and to achieve the requirements for remediation established for the Controlled Property until such time as this Environmental Easement is extinguished pursuant to ECL Article 71, Title 36; and

**NOW THEREFORE**, in consideration of the mutual covenants contained herein and the terms and conditions of Brownfield Cleanup Agreement Index Number: C203097-10-17 as amended July 17, 2019, Grantor conveys to Grantee a permanent Environmental Easement pursuant to ECL Article 71, Title 36 in, on, over, under, and upon the Controlled Property as more fully described herein ("Environmental Easement").

1. Purposes. Grantor and Grantee acknowledge that the Purposes of this Environmental Easement are: to convey to Grantee real property rights and interests that will run with the land in perpetuity in order to provide an effective and enforceable means of encouraging the reuse and redevelopment of this Controlled Property at a level that has been determined to be safe for a specific use while ensuring the performance of operation, maintenance, and/or monitoring

requirements; and to ensure the restriction of future uses of the land that are inconsistent with the above-stated purpose.

2. Institutional and Engineering Controls. The controls and requirements listed in the Department approved Site Management Plan ("SMP") including any and all Department approved amendments to the SMP are incorporated into and made part of this Environmental Easement. These controls and requirements apply to the use of the Controlled Property, run with the land, are binding on the Grantor and the Grantor's successors and assigns, and are enforceable in law or equity against any owner of the Controlled Property, any lessees and any person using the Controlled Property.

A. (1) The Controlled Property may be used for:

**Restricted Residential as described in 6 NYCRR Part 375-1.8(g)(2)(ii),  
Commercial as described in 6 NYCRR Part 375-1.8(g)(2)(iii) and Industrial  
as described in 6 NYCRR Part 375-1.8(g)(2)(iv)**

(2) All Engineering Controls must be operated and maintained as specified in the Site Management Plan (SMP);

(3) All Engineering Controls must be inspected at a frequency and in a manner defined in the SMP;

(4) The use of groundwater underlying the property is prohibited without necessary water quality treatment as determined by the NYSDOH or the New York City Department of Health and Mental Hygiene to render it safe for use as drinking water or for industrial purposes, and the user must first notify and obtain written approval to do so from the Department;

(5) Groundwater and other environmental or public health monitoring must be performed as defined in the SMP;

(6) Data and information pertinent to Site Management of the Controlled Property must be reported at the frequency and in a manner defined in the SMP;

(7) All future activities on the property that will disturb remaining contaminated material must be conducted in accordance with the SMP;

(8) Monitoring to assess the performance and effectiveness of the remedy must be performed as defined in the SMP;

(9) Operation, maintenance, monitoring, inspection, and reporting of any mechanical or physical components of the remedy shall be performed as defined in the SMP;

(10) Access to the site must be provided to agents, employees or other representatives of the State of New York with reasonable prior notice to the property owner to assure compliance with the restrictions identified by this Environmental Easement.

B. The Controlled Property shall not be used for Residential purposes as defined in

6NYCRR 375-1.8(g)(2)(i), and the above-stated engineering controls may not be discontinued without an amendment or extinguishment of this Environmental Easement.

C. The SMP describes obligations that the Grantor assumes on behalf of Grantor, its successors and assigns. The Grantor's assumption of the obligations contained in the SMP which may include sampling, monitoring, and/or operating a treatment system, and providing certified reports to the NYSDEC, is and remains a fundamental element of the Department's determination that the Controlled Property is safe for a specific use, but not all uses. The SMP may be modified in accordance with the Department's statutory and regulatory authority. The Grantor and all successors and assigns, assume the burden of complying with the SMP and obtaining an up-to-date version of the SMP from:

Site Control Section  
Division of Environmental Remediation  
NYSDEC  
625 Broadway  
Albany, New York 12233  
Phone: (518) 402-9553

D. Grantor must provide all persons who acquire any interest in the Controlled Property a true and complete copy of the SMP that the Department approves for the Controlled Property and all Department-approved amendments to that SMP.

E. Grantor covenants and agrees that until such time as the Environmental Easement is extinguished in accordance with the requirements of ECL Article 71, Title 36 of the ECL, the property deed and all subsequent instruments of conveyance relating to the Controlled Property shall state in at least fifteen-point bold-faced type:

**This property is subject to an Environmental Easement held by the New York State Department of Environmental Conservation pursuant to Title 36 of Article 71 of the Environmental Conservation Law.**

F. Grantor covenants and agrees that this Environmental Easement shall be incorporated in full or by reference in any leases, licenses, or other instruments granting a right to use the Controlled Property.

G. Grantor covenants and agrees that it shall, at such time as NYSDEC may require, submit to NYSDEC a written statement by an expert the NYSDEC may find acceptable certifying under penalty of perjury, in such form and manner as the Department may require, that:

- (1) the inspection of the site to confirm the effectiveness of the institutional and engineering controls required by the remedial program was performed under the direction of the individual set forth at 6 NYCRR Part 375-1.8(h)(3).
- (2) the institutional controls and/or engineering controls employed at such site:
  - (i) are in-place;

(ii) are unchanged from the previous certification, or that any identified changes to the controls employed were approved by the NYSDEC and that all controls are in the Department-approved format; and

(iii) that nothing has occurred that would impair the ability of such control to protect the public health and environment;

(3) the owner will continue to allow access to such real property to evaluate the continued maintenance of such controls;

(4) nothing has occurred that would constitute a violation or failure to comply with any site management plan for such controls;

(5) the report and all attachments were prepared under the direction of, and reviewed by, the party making the certification;

(6) to the best of his/her knowledge and belief, the work and conclusions described in this certification are in accordance with the requirements of the site remedial program, and generally accepted engineering practices; and

(7) the information presented is accurate and complete.

3. Right to Enter and Inspect. Grantee, its agents, employees, or other representatives of the State may enter and inspect the Controlled Property in a reasonable manner and at reasonable times to assure compliance with the above-stated restrictions.

4. Reserved Grantor's Rights. Grantor reserves for itself, its assigns, representatives, and successors in interest with respect to the Property, all rights as fee owner of the Property, including:

A. Use of the Controlled Property for all purposes not inconsistent with, or limited by the terms of this Environmental Easement;

B. The right to give, sell, assign, or otherwise transfer part or all of the underlying fee interest to the Controlled Property, subject and subordinate to this Environmental Easement;

5. Enforcement

A. This Environmental Easement is enforceable in law or equity in perpetuity by Grantor, Grantee, or any affected local government, as defined in ECL Section 71-3603, against the owner of the Property, any lessees, and any person using the land. Enforcement shall not be defeated because of any subsequent adverse possession, laches, estoppel, or waiver. It is not a defense in any action to enforce this Environmental Easement that: it is not appurtenant to an interest in real property; it is not of a character that has been recognized traditionally at common law; it imposes a negative burden; it imposes affirmative obligations upon the owner of any interest in the burdened property; the benefit does not touch or concern real property; there is no privity of estate or of contract; or it imposes an unreasonable restraint on alienation.

B. If any person violates this Environmental Easement, the Grantee may revoke the Certificate of Completion with respect to the Controlled Property.

C. Grantee shall notify Grantor of a breach or suspected breach of any of the terms of this Environmental Easement. Such notice shall set forth how Grantor can cure such breach or suspected breach and give Grantor a reasonable amount of time from the date of receipt of notice in which to cure. At the expiration of such period of time to cure, or any extensions granted by Grantee, the Grantee shall notify Grantor of any failure to adequately cure the breach or suspected

breach, and Grantee may take any other appropriate action reasonably necessary to remedy any breach of this Environmental Easement, including the commencement of any proceedings in accordance with applicable law.

D. The failure of Grantee to enforce any of the terms contained herein shall not be deemed a waiver of any such term nor bar any enforcement rights.

6. Notice. Whenever notice to the Grantee (other than the annual certification) or approval from the Grantee is required, the Party providing such notice or seeking such approval shall identify the Controlled Property by referencing the following information:

County, NYSDEC Site Number, NYSDEC Brownfield Cleanup Agreement, State Assistance Contract or Order Number, and the County tax map number or the Liber and Page or computerized system identification number.

Parties shall address correspondence to:      Site Number: C203097  
Office of General Counsel  
NYSDEC  
625 Broadway  
Albany New York 12233-5500

With a copy to:                                      Site Control Section  
Division of Environmental Remediation  
NYSDEC  
625 Broadway  
Albany, NY 12233

All notices and correspondence shall be delivered by hand, by registered mail or by Certified mail and return receipt requested. The Parties may provide for other means of receiving and communicating notices and responses to requests for approval.

7. Recordation. Grantor shall record this instrument, within thirty (30) days of execution of this instrument by the Commissioner or her/his authorized representative in the office of the recording officer for the county or counties where the Property is situated in the manner prescribed by Article 9 of the Real Property Law.

8. Amendment. Any amendment to this Environmental Easement may only be executed by the Commissioner of the New York State Department of Environmental Conservation or the Commissioner's Designee, and filed with the office of the recording officer for the county or counties where the Property is situated in the manner prescribed by Article 9 of the Real Property Law.

9. Extinguishment. This Environmental Easement may be extinguished only by a release by the Commissioner of the New York State Department of Environmental Conservation, or the Commissioner's Designee, and filed with the office of the recording officer for the county or counties where the Property is situated in the manner prescribed by Article 9 of the Real Property Law.

10. Joint Obligation. If there are two or more parties identified as Grantor herein, the obligations imposed by this instrument upon them shall be joint and several.

11. Consistency with the SMP. To the extent there is any conflict or inconsistency between the terms of this Environmental Easement and the SMP, regarding matters specifically addressed by the SMP, the terms of the SMP will control.

**Remainder of Page Intentionally Left Blank**





IN WITNESS WHEREOF, LDC Leaseholder has caused this instrument to be signed in its name.

MHANY PENINSULA LOCAL DEVELOPMENT CORPORATION, a New York not-for-profit corporation

By: Ismene Speliotis  
Name: Ismene Speliotis  
Title: Executive Director

LDC Leaseholder's Acknowledgment

STATE OF NEW YORK )  
COUNTY OF Kings ) ss:

On the 13 day of October, in the year 2020, before me, the undersigned, personally appeared Ismene Speliotis, personally known to me or proved to me on the basis of satisfactory evidence to be the individual(s) whose name is (are) subscribed to the within instrument and acknowledged to me that he/she/they executed the same in his/her/their capacity(ies), and that by his/her/their signature(s) on the instrument, the individual(s), or the person upon behalf of which the individual(s) acted, executed the instrument.

[Signature]  
Notary Public - State of New York



IN WITNESS WHEREOF, HDFC Leaseholder has caused this instrument to be signed in its name.

SPOFFORD 1B HOUSING DEVELOPMENT FUND CORPORATION, a New York not-for-profit corporation

By:   
Name: Ismene Speliotis  
Title: Executive Director

**HDFC Leaseholder's Acknowledgment**

STATE OF NEW YORK )  
COUNTY OF Kings ) ss:  
)

On the 13 day of October, in the year 2020, before me, the undersigned, personally appeared Ismene Speliotis, personally known to me or proved to me on the basis of satisfactory evidence to be the individual(s) whose name is (are) subscribed to the within instrument and acknowledged to me that he/she/they executed the same in his/her/their capacity(ies), and that by his/her/their signature(s) on the instrument, the individual(s), or the person upon behalf of which the individual(s) acted, executed the instrument.

  
Notary Public State of New York



**IN WITNESS WHEREOF**, Beneficial Leaseholder has caused this instrument to be signed in its name.

PENINSULA BUILDING 1B LLC,  
a New York limited liability company

By: Peninsula Building 1B MM LLC, its managing member

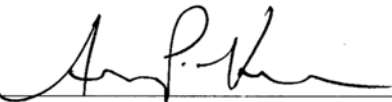
By:   
Name: Aaron Koffman  
Title: Authorized Signatory

**Beneficial Leaseholder's Acknowledgment**

STATE OF NEW YORK    )  
  ) ss:  
COUNTY OF *Kings*    )

On the *28<sup>th</sup>* day of ~~September~~ *September*, in the year 2020, before me, the undersigned, personally appeared *Aaron Koffman*, personally known to me or proved to me on the basis of satisfactory evidence to be the individual(s) whose name is (are) subscribed to the within instrument and acknowledged to me that he/she/they executed the same in his/her/their capacity(ies), and that by his/her/their signature(s) on the instrument, the individual(s), or the person upon behalf of which the individual(s) acted, executed the instrument.

  
Notary Public - State of New York

FATMATA K. JALLOH  
NOTARY PUBLIC, STATE OF NEW YORK  
Registration No. 01JA6332614  
Qualified in Westchester County  
Commission Expires November 2, 20 *23*

**THIS ENVIRONMENTAL EASEMENT IS HEREBY ACCEPTED BY THE PEOPLE OF THE STATE OF NEW YORK**, Acting By and Through the Department of Environmental Conservation as Designee of the Commissioner,

By:   
Michael J. Ryan, Director  
Division of Environmental Remediation

**Grantee's Acknowledgment**

STATE OF NEW YORK    )  
  ) ss:  
COUNTY OF ALBANY    )

On the 1<sup>st</sup> day of DECEMBER in the year 2020 before me, the undersigned, personally appeared Michael J. Ryan, personally known to me or proved to me on the basis of satisfactory evidence to be the individual(s) whose name is (are) subscribed to the within instrument and acknowledged to me that he/she/ executed the same in his/her/ capacity as Designee of the Commissioner of the State of New York Department of Environmental Conservation, and that by his/her/ signature on the instrument, the individual, or the person upon behalf of which the individual acted, executed the instrument.

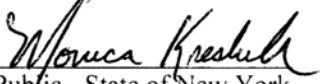
  
Notary Public - State of New York

MONICA KRESHNIK, ESQ.  
Notary Public, State of New York  
No. 02KR6314859  
Qualified in Rensselaer County  
Commission Expires 11/17/2022

**SCHEDULE "A" PROPERTY DESCRIPTION**

**METES & BOUNDS DESCRIPTION**  
ENVIRONMENTAL EASEMENT  
LOTS 35, 36 & 37, BLOCK 2738  
BOROUGH & COUNTY OF BRONX  
CITY & STATE OF NEW YORK

ALL THAT CERTAIN PLOT, PIECE OR PARCEL OF LAND, SITUATE, LYING AND BEING IN THE BOROUGH OF BRONX, COUNTY OF BRONX, CITY AND STATE OF NEW YORK, MORE PARTICULARLY BOUNDED AND DESCRIBED AS FOLLOWS;

BEGINNING AT A POINT FORMED BY THE INTERSECTION OF THE NORTHEASTERLY LINE OF TIFFANY STREET (80 FEET WIDE) WITH THE NORTHWESTERLY LINE OF SPOFFORD AVENUE (100 FEET WIDE) AND FROM SAID BEGINNING POINT RUNNING, THENCE;

1. NORTHWESTERLY, ALONG THE AFOREMENTIONED NORTHEASTERLY LINE OF TIFFANY STREET, A DISTANCE OF 342.28 FEET TO A POINT, THENCE;
2. NORTHEASTERLY, ALONG THE NORTHERLY LINE OF LOT 37, BLOCK 2738, SAID LINE FORMING AN ANGLE OF 91 DEGREES - 17 MINUTES - 38 SECONDS ON ITS EASTERLY SIDE WITH THE LAST DESCRIBED LINE, A DISTANCE OF 79.01 FEET TO AN ANGLE POINT THEREIN, THENCE;
3. CONTINUING NORTHEASTERLY, ALONG SAID NORTHERLY LINE OF LOT 37 AND ALONG THE NORTHERLY LINE OF LOT 35, BLOCK 2738, SAID LINE FORMING AN ANGLE OF 179 DEGREES - 50 MINUTES - 13 SECONDS ON ITS SOUTHERLY SIDE WITH THE LAST DESCRIBED LINE, A DISTANCE OF 395.53 FEET TO A POINT, THENCE;
4. SOUTHEASTERLY, ALONG THE SOUTHERLY LINE OF FORMER BARRETTO STREET, FORMING AN ANGLE OF 86 DEGREES - 59 MINUTES - 32 SECONDS ON ITS SOUTHERLY SIDE, A DISTANCE OF 352.07 FEET TO A POINT IN SAID NORTHWESTERLY LINE OF SPOFFORD AVENUE, THENCE;
5. SOUTHWESTERLY, ALONG SAID NORTHWESTERLY LINE OF SPOFFORD AVENUE, FORMING AN ANGLE OF 91 DEGREES - 52 MINUTES - 37 SECONDS ON ITS WESTERLY SIDE, A DISTANCE OF 462.92 FEET TO THE POINT AND PLACE OF BEGINNING.

CONTAINING 162,688 SQUARE FEET OR 3.7348 ACRES.

- REFERENCES:
- GRADE MAP, SECTION 4, PROVIDED BY THE CITY OF NEW YORK, BOROUGH OF THE BRONX, OFFICE OF THE PRESIDENT, ENGINEERING BUREAU, TOPOGRAPHICAL DIVISION, LAST REVISED: DECEMBER 23, 1998.
  - RECORD MAP, SECTION 4, PROVIDED BY THE CITY OF NEW YORK, BOROUGH OF THE BRONX, OFFICE OF THE PRESIDENT, ENGINEERING BUREAU, TOPOGRAPHICAL DIVISION, LAST REVISED: OCTOBER 24, 1995.
  - TITLE MAP, SECTION 5 PROVIDED BY THE CITY OF NEW YORK, BOROUGH OF THE BRONX, OFFICE OF THE PRESIDENT, ENGINEERING BUREAU, TOPOGRAPHICAL DIVISION.
  - CITY OF NEW YORK, BOROUGH OF THE BRONX, OFFICE OF THE PRESIDENT, ENGINEERING BUREAU, TOPOGRAPHICAL DIVISION, MAP SHOWING THE CHANGES OF GRADES OF SPOFFORD AVE. FROM TIFFANY STREET TO MANHA STREET AND CASANOVA STREET FROM SPOFFORD AVE. TO RANDALL AVE., AMENDMENT TO SECTION 4, PLAN NO. 10732, DATED: FEBRUARY 27, 1928.
  - CITY OF NEW YORK, OFFICE OF THE PRESIDENT OF THE BOROUGH OF THE BRONX, ELIMINATION OF BARRETTO STREET FROM SPOFFORD AVE. TO A POINT 20 FEET SOUTH OF LAFAYETTE AVE., AND THE ADJUSTMENT OF LINES AND GRADES NECESSITATED THEREBY, AMENDMENT TO SECTION 4, PLAN NO. 11404, DATED: NOVEMBER 25, 1953.
  - CITY OF NEW YORK, DEPARTMENT OF PUBLIC WORKS, DIVISION OF BUILDINGS, SHELTER FOR DELINQUENT CHILDREN (BOYS), 1221 SPOFFORD AVENUE, BOROUGH OF THE BRONX FOR THE DEPARTMENT OF WELFARE, TOPOGRAPHICAL MAP 131E GRADING AND CONSTRUCTION PLAN, PREPARED BY KAHN AND JACOBS ARCHITECTS, DATED: MARCH 21, 1955, C.O.B. NO. WL-26, SHEET NOS. A-1 & A-2 OF 53.
  - IN THE MATTER OF THE APPLICATION OF THE CITY OF NEW YORK RELATIVE TO ACQUIRING TITLE TO ALL OR PARTS OF LOT 2 AT NA BARRETTO STREET, LOT 1 AT 160 MANHA STREET, BLOCK 2763, BETWEEN TIFFANY AND MANHA STREET, IN THE BOROUGH OF THE BRONX, CITY AND STATE OF NEW YORK, REQUIRED TO ESTABLISH LEASED PARCELS IN CONNECTION WITH THE BRONX URBAN RENAISSANCE PROJECT, PREPARED BY HWS ENGINEERS ARCHITECTS & LAND SURVEYORS, P.C., DATED: OCTOBER 5, 2016.
  - CAD FILE PROVIDED BY CLIENT CONTAINING NEW DISPOSITION/PROPERTY AREA RECEIVED FEBRUARY 24, 2020.
  - BOUNDARY & TOPOGRAPHIC SURVEY, LOT 35, BLOCK 2738, LOT 29, BLOCK 2763, PART OF LOTS 1 & 2, BLOCK 2763, 707 BARRETTO STREET AND 711-765 MANHA STREET, BOROUGH & COUNTY OF BRONX, CITY & STATE OF NEW YORK, PREPARED BY GALLAS SURVEYING GROUP, DATED: OCTOBER 5, 2017, LAST REVISED: NOVEMBER 2, 2018.
  - ALTANSPS LAND TITLE SURVEY, LOT 36, BLOCK 2738, 1215 SPOFFORD AVENUE, BOROUGH & COUNTY OF BRONX, CITY & STATE OF NEW YORK, PREPARED BY GALLAS SURVEYING GROUP, DATED: APRIL 2, 2019.
  - ALTANSPS LAND TITLE SURVEY, LOT 37, BLOCK 2738, 720 TIFFANY STREET, BOROUGH & COUNTY OF BRONX, CITY & STATE OF NEW YORK, PREPARED BY GALLAS SURVEYING GROUP, DATED: FEBRUARY 13, 2019, LAST REVISED: MARCH 15, 2019.
  - ZONING LOT PLAN, PREPARED BY BLA & NYX, DATED: FEBRUARY 24, 2020, DRAWING NUMBER A-001.
  - REMEDIAL ALTERNATIVE 2: TRACK 4 CLEANUP, REMEDIAL ACTION WORK PLAN, 1221 SPOFFORD AVENUE, BRONX, NEW YORK, PREPARED FOR, THE PENNSYLVANIA, JV, LLC, PREPARED BY ROCK, DATED SEPTEMBER 5, 2018.

**TIFFANY STREET**  
(60' WIDE - PUBLIC)  
(TITLE VESTED JANUARY 6, 1897)

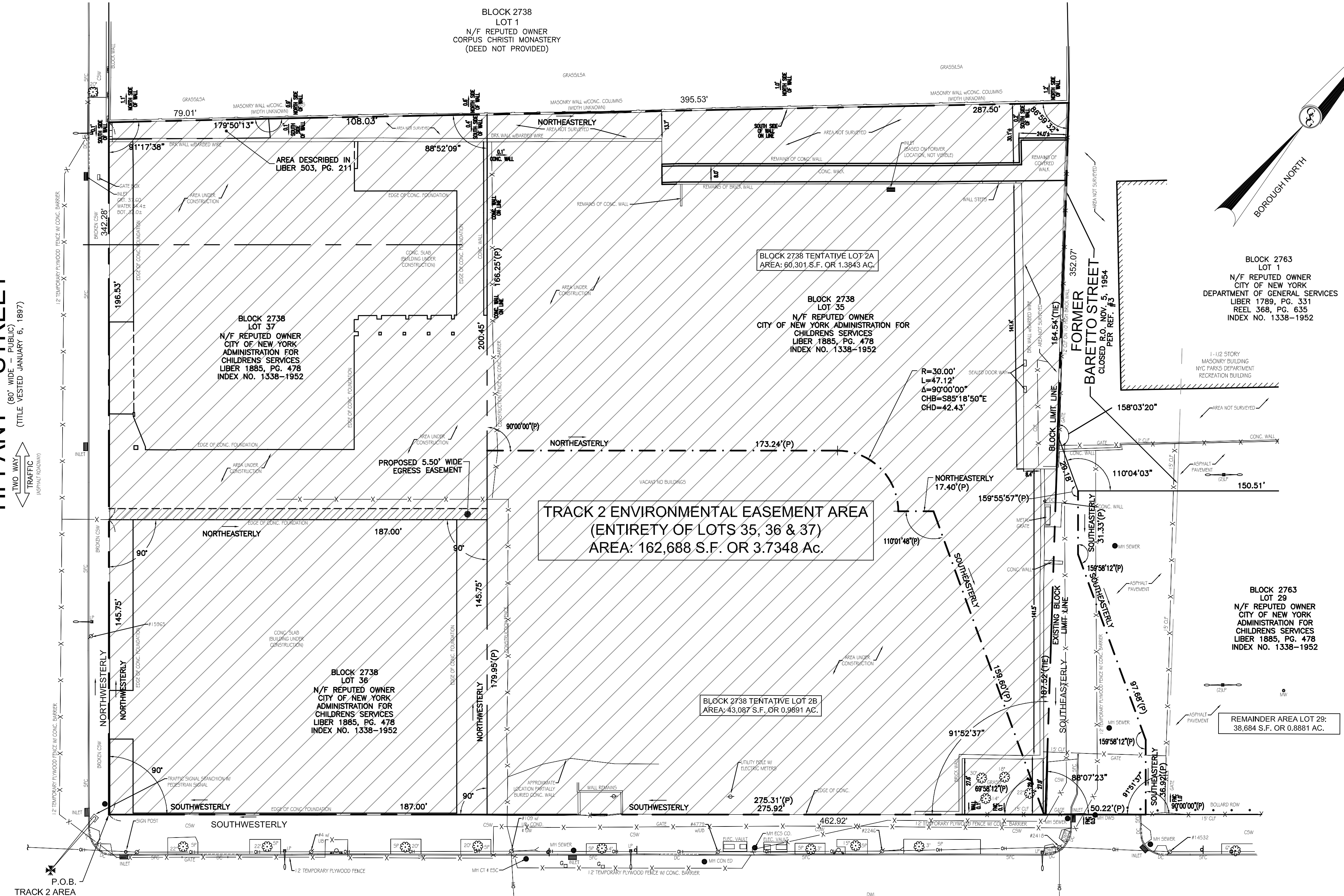

- METES & BOUNDS DESCRIPTIONS**
- LOT 35, BLOCK 2738**
- ALL THAT CERTAIN PLOT, PIECE OR PARCEL OF LAND, SITUATE, LYING AND BEING IN THE BOROUGH OF BRONX, COUNTY OF BRONX, CITY AND STATE OF NEW YORK, MORE PARTICULARLY BOUNDED AND DESCRIBED AS FOLLOWS:
- BEGINNING AT A POINT IN THE NORTHWESTERLY LINE OF SPOFFORD AVENUE (100 FEET WIDE), SAID POINT BEING DISTANT NORTH-EASTERLY, A DISTANCE OF 187.00 FEET FROM A POINT FORMED BY THE INTERSECTION OF SAID NORTHWESTERLY LINE OF SPOFFORD AVENUE WITH THE NORTHWESTERLY LINE OF TIFFANY STREET (80 FEET WIDE) AND FROM SAID BEGINNING POINT RUNNING, THENCE:
- NORTHWESTERLY, ALONG A LINE PARALLEL TO TIFFANY STREET, FORMING AN ANGLE OF 90 DEGREES - 00 MINUTES - 00 SECONDS ON ITS WESTERLY SIDE, A DISTANCE OF 342.28 FEET TO A POINT, THENCE;
  - NORTHEASTERLY, ALONG THE NORTHERLY LINE OF LOT 35, BLOCK 2738, FORMING AN ANGLE OF 91 DEGREES - 07 MINUTES - 59 SECONDS ON ITS EASTERLY SIDE, A DISTANCE OF 287.50 FEET TO A POINT, THENCE;
  - SOUTHEASTERLY, ALONG THE SOUTHERLY LINE OF FORMER BARRETTO STREET, FORMING AN ANGLE OF 86 DEGREES - 59 MINUTES - 32 SECONDS ON ITS SOUTHERLY SIDE, A DISTANCE OF 352.07 FEET TO A POINT IN SAID NORTHWESTERLY LINE OF SPOFFORD AVENUE, THENCE;
  - SOUTHWESTERLY, ALONG SAID NORTHWESTERLY LINE OF SPOFFORD AVENUE, FORMING AN ANGLE OF 91 DEGREES - 52 MINUTES - 37 SECONDS ON ITS WESTERLY SIDE, A DISTANCE OF 275.92 FEET TO THE POINT AND PLACE OF BEGINNING.
- LOT 36, BLOCK 2738**
- ALL THAT CERTAIN PLOT, PIECE OR PARCEL OF LAND, SITUATE, LYING AND BEING IN THE BOROUGH OF BRONX, COUNTY OF BRONX, CITY AND STATE OF NEW YORK, MORE PARTICULARLY BOUNDED AND DESCRIBED AS FOLLOWS:
- BEGINNING AT A POINT FORMED BY THE INTERSECTION OF THE NORTH-EASTERLY LINE OF TIFFANY STREET (80 FEET WIDE) WITH THE NORTHWESTERLY LINE OF SPOFFORD AVENUE (100 FEET WIDE) AND FROM SAID BEGINNING POINT RUNNING, THENCE:
- NORTHWESTERLY, ALONG THE NORTHWESTERLY LINE OF TIFFANY STREET, A DISTANCE OF 145.75 FEET TO A POINT, THENCE;
  - NORTHEASTERLY, ALONG THE NORTHERLY LINE OF LOT 36, BLOCK 2738, SAID LINE FORMING AN ANGLE OF 90 DEGREES - 00 MINUTES - 00 SECONDS ON ITS EASTERLY SIDE WITH THE LAST DESCRIBED LINE, A DISTANCE OF 187.00 FEET TO A POINT, THENCE;
  - SOUTHEASTERLY, ALONG A LINE PARALLEL TO TIFFANY STREET, FORMING AN ANGLE OF 90 DEGREES - 00 MINUTES - 00 SECONDS ON ITS SOUTHERLY SIDE, A DISTANCE OF 145.75 FEET TO A POINT IN SAID NORTHWESTERLY LINE OF SPOFFORD AVENUE, THENCE;
  - SOUTHWESTERLY, ALONG SAID NORTHWESTERLY LINE OF SPOFFORD AVENUE, FORMING AN ANGLE OF 90 DEGREES - 00 MINUTES - 00 SECONDS ON ITS WESTERLY SIDE, A DISTANCE OF 187.00 FEET TO THE POINT AND PLACE OF BEGINNING.
- LOT 37, BLOCK 2738**
- ALL THAT CERTAIN PLOT, PIECE OR PARCEL OF LAND, SITUATE, LYING AND BEING IN THE BOROUGH OF BRONX, COUNTY OF BRONX, CITY AND STATE OF NEW YORK, MORE PARTICULARLY BOUNDED AND DESCRIBED AS FOLLOWS:
- BEGINNING AT A POINT IN THE NORTH-EASTERLY LINE OF TIFFANY STREET (80 FEET WIDE), SAID POINT BEING DISTANT NORTHWESTERLY, A DISTANCE OF 145.75 FEET FROM A POINT FORMED BY THE INTERSECTION OF SAID NORTHWESTERLY LINE OF TIFFANY STREET WITH THE NORTHWESTERLY LINE OF SPOFFORD AVENUE (100 FEET WIDE) AND FROM SAID BEGINNING POINT RUNNING, THENCE:
- NORTHWESTERLY, ALONG THE NORTHWESTERLY LINE OF TIFFANY STREET, A DISTANCE OF 196.53 FEET TO A POINT, THENCE;
  - NORTHEASTERLY, ALONG THE NORTHERLY LINE OF LOT 37, BLOCK 2738, SAID LINE FORMING AN ANGLE OF 91 DEGREES - 17 MINUTES - 38 SECONDS ON ITS EASTERLY SIDE WITH THE LAST DESCRIBED LINE, A DISTANCE OF 79.01 FEET TO AN ANGLE POINT THEREIN, THENCE;
  - CONTINUING NORTH-EASTERLY, ALONG SAID NORTHERLY LINE OF LOT 37, BLOCK 2738, SAID LINE FORMING AN ANGLE OF 179 DEGREES - 50 MINUTES - 13 SECONDS ON ITS SOUTHERLY SIDE WITH THE LAST DESCRIBED LINE, A DISTANCE OF 108.03 FEET TO A POINT, THENCE;
  - SOUTHEASTERLY, ALONG A LINE PARALLEL TO TIFFANY STREET, FORMING AN ANGLE OF 88 DEGREES - 52 MINUTES - 09 SECONDS ON ITS SOUTHERLY SIDE, A DISTANCE OF 200.45 FEET TO A POINT, THENCE;
  - SOUTHWESTERLY, ALONG A LINE PARALLEL TO SPOFFORD AVENUE, FORMING AN ANGLE OF 90 DEGREES - 00 MINUTES - 00 SECONDS ON ITS WESTERLY SIDE, A DISTANCE OF 187.00 FEET TO THE POINT AND PLACE OF BEGINNING.
- ENVIRONMENTAL TRACK 2 METES AND BOUNDS DESCRIPTION:**
- ALL THAT CERTAIN PLOT, PIECE OR PARCEL OF LAND, SITUATE, LYING AND BEING IN THE BOROUGH OF BRONX, COUNTY OF BRONX, CITY AND STATE OF NEW YORK, MORE PARTICULARLY BOUNDED AND DESCRIBED AS FOLLOWS:
- BEGINNING AT A POINT FORMED BY THE INTERSECTION OF THE NORTH-EASTERLY LINE OF TIFFANY STREET (80 FEET WIDE) WITH THE NORTHWESTERLY LINE OF SPOFFORD AVENUE (100 FEET WIDE) AND FROM SAID BEGINNING POINT RUNNING, THENCE:
- NORTHWESTERLY, ALONG THE NORTHWESTERLY LINE OF TIFFANY STREET, A DISTANCE OF 342.28 FEET TO A POINT, THENCE;
  - NORTHEASTERLY, ALONG THE NORTHERLY LINE OF LOT 37, BLOCK 2738, SAID LINE FORMING AN ANGLE OF 91 DEGREES - 17 MINUTES - 38 SECONDS ON ITS EASTERLY SIDE WITH THE LAST DESCRIBED LINE, A DISTANCE OF 79.01 FEET TO AN ANGLE POINT THEREIN, THENCE;
  - CONTINUING NORTH-EASTERLY, ALONG SAID NORTHERLY LINE OF LOT 37 AND ALONG THE NORTHERLY LINE OF LOT 35, BLOCK 2738, SAID LINE FORMING AN ANGLE OF 179 DEGREES - 50 MINUTES - 13 SECONDS ON ITS SOUTHERLY SIDE WITH THE LAST DESCRIBED LINE, A DISTANCE OF 395.53 FEET TO A POINT, THENCE;
  - SOUTHEASTERLY, ALONG THE SOUTHERLY LINE OF FORMER BARRETTO STREET, FORMING AN ANGLE OF 86 DEGREES - 59 MINUTES - 32 SECONDS ON ITS SOUTHERLY SIDE, A DISTANCE OF 352.07 FEET TO A POINT IN SAID NORTHWESTERLY LINE OF SPOFFORD AVENUE, THENCE;
  - SOUTHWESTERLY, ALONG SAID NORTHWESTERLY LINE OF SPOFFORD AVENUE, FORMING AN ANGLE OF 91 DEGREES - 52 MINUTES - 37 SECONDS ON ITS WESTERLY SIDE, A DISTANCE OF 462.92 FEET TO THE POINT AND PLACE OF BEGINNING.
- CONTAINING 162,688 SQUARE FEET OR 3.7348 ACRES.

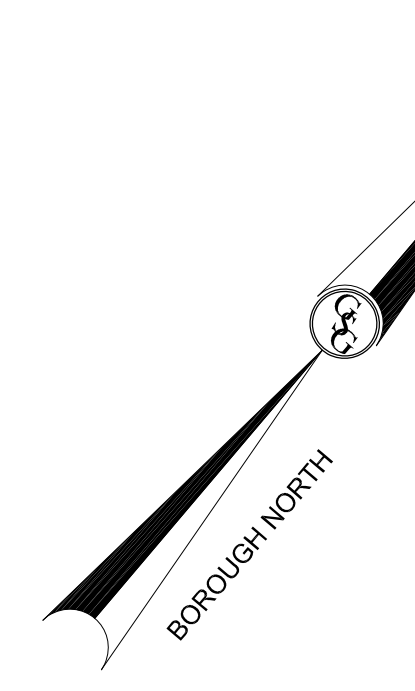

- ABBREVIATIONS**
- BRK BRICK
  - CLP CHAIN LINK FENCE
  - CONC CONCRETE
  - COND CONDUIT
  - CSW CONCRETE SIDEWALK
  - DC DEPRESSED CURB
  - LSA LANDSCAPED AREA
  - SFC STEEL FACED CONCRETE CURB
  - SP STONE PAVERS
  - UB UTILITY BOX
  - FNC FENCE

- MAP LEGEND**
- TRACK 2 ENVIRONMENTAL EASEMENT
  - PROPERTY LINE
  - PROPOSED TENTATIVE LOT LINE
  - BUILDING FOOTPRINT AND DOORWAY AT GROUND LEVEL
  - DOORWAY IN WALL
  - HYDRANT
  - WATER VALVE
  - GAS VALVE
  - OVERHEAD WIRES
  - FIRE DEPARTMENT CONNECTION
  - MONITORING WELL
  - MANHOLE
  - INLET
  - UTILITY POLE
  - UTILITY POLE/LIGHT POLE
  - LIGHT POLE
  - GUY WIRE
  - BOLLARD
  - SIGN
  - DETECTABLE WARNING PAD
  - 240.96'(P)
  - 160'00'04'(P)
  - 1.0'
  - PROPOSED DISTANCE
  - PROPOSED ANGLE
  - DENOTES OFFSET OF STRUCTURE AT GROUND LEVEL RELATIVE TO PROPERTY LINE

**SPOFFORD AVENUE**  
(100' WIDE - PUBLIC)  
(TITLE VESTED MARCH 13, 1901)

**CASANOVA STREET**  
(60' WIDE - PUBLIC)

**BARRETTO STREET**  
(60' WIDE - PUBLIC)

*This property is subject to an environmental easement held by the New York State Department of Environmental Conservation pursuant to Title 36 of Article 71 of the New York Environmental Conservation Law. The engineering and institutional controls for this Easement are set forth in the Site Management Plan (SMP). A copy of the SMP must be obtained by any party with an interest in the property. The SMP can be obtained from NYS Department of Environmental Conservation, Division of Environmental Remediation, Site Control Section, 625 Broadway, Albany, NY 12233 or at [derweb@dec.ny.gov](mailto:derweb@dec.ny.gov)*

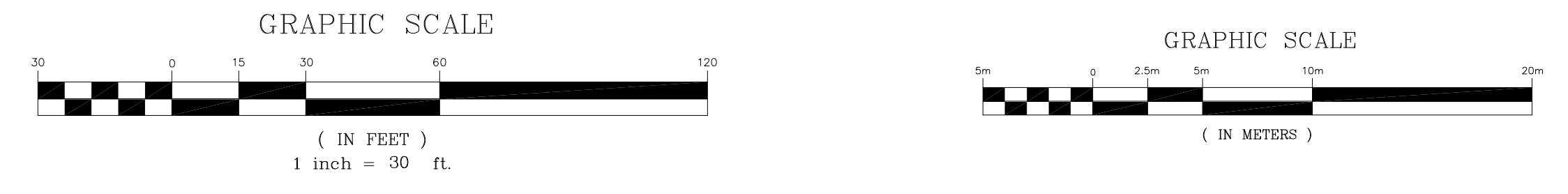

- NOTES:**
- PROPERTY KNOWN AS LOTS 35, 36 & 37 IN BLOCK 2738 AS DESIGNATED ON THE NEW YORK CITY DIGITAL TAX MAPS, HAVING AN EFFECTIVE DATE OF DECEMBER 23, 2018
  - AREA OF LOT 35, BLOCK 2738: 98,303 S.F. OR 2.2567 AC.  
AREA OF LOT 36, BLOCK 2738: 27,252 S.F. OR 0.6257 AC.  
AREA OF LOT 37, BLOCK 2738: 37,130 S.F. OR 0.8524 AC.  
TOTAL AREA: 162,688 S.F. OR 3.7348 AC.
  - LOCATION OF UNDERGROUND UTILITIES HAVE BEEN OMITTED FROM THIS PLAN. BEFORE ANY EXCAVATION IS TO BEGAIN, ALL UNDERGROUND UTILITIES SHOULD BE VERIFIED AS TO THEIR LOCATION, SIZE AND TYPE BY THE PROPER UTILITY COMPANIES.
  - THIS SURVEY WAS PREPARED WITH REFERENCE TO A TITLE COMMITMENT REPORT PREPARED BY CHICAGO TITLE INSURANCE COMPANY, TITLE NO. CT16-004638X, HAVING AN EFFECTIVE DATE OF APRIL 27, 2016, FOR THE OVERALL PROPERTY.
  - THIS SURVEY WAS PREPARED WITH BENEFIT OF A CERTIFICATE OF TITLE PREPARED BY ALL NEW YORK TITLE AGENCY, INC., AGENT FOR FIDELITY NATIONAL TITLE INSURANCE COMPANY, TITLE NO. ANY2018-0407C, EFFECTIVE DATE OF MARCH 15, 2019, FOR LOT 36, BLOCK 2738.
  - THIS SURVEY WAS PREPARED WITH BENEFIT OF A TITLE COMMITMENT REPORT PREPARED BY CHICAGO TITLE INSURANCE COMPANY, TITLE NO. CT19-00684-8X, EFFECTIVE DATE OF JANUARY 21, 2019, FOR LOT 36, BLOCK 2738.
  - BY GRAPHIC PLOTTING, PROPERTY IS LOCATED IN FLOOD HAZARD ZONE X (AREAS DETERMINED TO BE OUTSIDE THE 0.2% ANNUAL CHANCE FLOODPLAIN) PER NATIONAL FLOOD INSURANCE PROGRAM FLOOD INSURANCE RATE MAP NO. 360497047, MAP REVISED: SEPTEMBER 8, 2009.
  - BE ADVISED THAT FEMA HAS POSTED A PRELIMINARY MAP FOR THIS AREA AND SHOWS THE PROPERTY LOCATED IN FLOOD HAZARD ZONE X (AREAS DETERMINED TO BE OUTSIDE THE 0.2% ANNUAL CHANCE FLOODPLAIN) MAP NUMBER 3604970084G, DATED: DECEMBER 5, 2013.
  - THERE WERE NO VISIBLE STREAMS OR NATURAL WATER COURSES IN THE PROPERTY AT THE TIME OF FIELD SURVEY.
  - THIS SITE IS ACTIVELY UNDER CONSTRUCTION. FEATURES SHOWN INSIDE THE CONSTRUCTION FENCE MAY NOT REFLECT CURRENT CONDITIONS.

3	REVISE TO ADD INDIVIDUAL PROPERTY DESCRIPTIONS	C.J.L.	06-08-2020
2	REVISE PER CLIENT COMMENTS	C.J.L.	05-28-2020
1	REVISE PER CLIENT COMMENTS	C.J.L.	05-14-2020
No.	DESCRIPTION OF REVISION	DRAWN:	DATE

**TRACK 2 ENVIRONMENTAL EASEMENT SKETCH LOTS 35-37, BLOCK 2738**  
1221 SPOFFORD AVENUE  
BOROUGH & COUNTY OF BRONX  
CITY & STATE OF NEW YORK

**GALLAS SURVEYING GROUP**  
2863 U.S. ROUTE 1  
NORTH BRUNSWICK, NJ 08902  
TELE: 732-423-7000  
FAX: 732-423-7076  
www.gallasurvey.com

DATE	SCALE	DRAWN:	CHECKED:
05-01-2020	1"=30'	K.G.G./C.J.L.	G.S.G.
FIELD DATE	FIELD BOOK	PAGE	FIELD CROW
03-05-2020	132	120-122	D.A./A.S.
03-16-2020	135	58	P.P./K.C.
04-02-2020	135	86-84	A.S./A.S.
FILE NO.	DRAWING NAME/SHEET NO.		1 of 1
G16266	G16266B2.DWG		

UNAUTHORIZED ALTERATION OR ADDITION TO A SURVEY MAP BEARING A LICENSED LAND SURVEYOR'S SEAL IS A VIOLATION OF SECTION 7209, SUB-DIVISION 2, OF THE NEW YORK STATE EDUCATION LAW.

**GREGORY S. GALLAS**  
NEW YORK PROFESSIONAL LAND SURVEYOR #00724

DATE: 06-09-2020

**APPENDIX B**

List of Site Contacts

**APPENDIX B – LIST OF SITE CONTACTS**

<b>Name</b>	<b>Phone/Email Address</b>
Site Owner: The Peninsula JV, LLC	(401) 588-3150 <a href="mailto:ebroderick@gilbaneco.com">ebroderick@gilbaneco.com</a>
Owner Representatives: Ed Broderick	(401) 588-3150 <a href="mailto:ebroderick@gilbaneco.com">ebroderick@gilbaneco.com</a>
Remedial Party: The Peninsula JV, LLC	(401) 588-3150 <a href="mailto:ebroderick@gilbaneco.com">ebroderick@gilbaneco.com</a>
Qualified Environmental Professional: Brian Morrissey, P.E. Roux Environmental Engineering and Geology, D.P.C.	(631) 232-2600 (Office) (631) 921-6355 (Mobile) bmorrissey@rouxinc.com
NYSDEC, DER, Bureau of Technical Support Site Control Section	Chief, Site Control Section New York State Department of Environmental Conservation Division of Environmental Remediation 625 Broadway Albany NY 12233-7020
NYSDEC Project Manager: Wendi Zheng, NYSDEC	<a href="mailto:wendi.zheng@dec.ny.gov">wendi.zheng@dec.ny.gov</a>
Chief, NYSDEC, Superfund and Brownfield Cleanup Section: Jane O’Connell, NYSDEC	<a href="mailto:jane.oconnell@dec.ny.gov">jane.oconnell@dec.ny.gov</a>
Sondra Martinkat, NYSDEC	<a href="mailto:sondra.martinkat@dec.ny.gov">sondra.martinkat@dec.ny.gov</a>
NYSDOH Project Manager: Krista Anders	<a href="mailto:krista.anders@health.ny.gov">krista.anders@health.ny.gov</a>
Attorney: Lawrence Schnapf	(212) 876-3189 <a href="mailto:Larry@schnapflaw.com">Larry@schnapflaw.com</a>



Responsibilities of Owner and Remedial Party

## **Responsibilities**

The responsibilities for implementing the Site Management Plan (“SMP”) for The Peninsula site (the “site”), number C203097, are divided between the site owner(s) and a Remedial Party, as defined below. The owner(s) is/are currently listed as:

- The City of New York.

**Solely for the purposes of this document and based upon the facts related to a particular site and the remedial program being carried out**, the term Remedial Party (“RP”) refers to any of the following: certificate of completion holder, volunteer, applicant, responsible party, and, in the event the New York State Department of Environmental Conservation (“NYSDEC”) is carrying out remediation or site management, the NYSDEC and/or an agent acting on its behalf. The RP is: The Peninsula JV, LLC, Blaise Rastello, 7 Jackson Walkway, Providence, Rhode Island 02903. The RP currently holds a ground lease with the property owner (lessor). The ground lessor will not be responsible for complying with the SMP.

Nothing on this page shall supersede the provisions of an Environmental Easement, Consent Order, Consent Decree, agreement, or other legally binding document that affects rights and obligations relating to the site.

## **Site Owner’s Responsibilities:**

- 1) The owner shall follow the provisions of the SMP as they relate to future construction and excavation at the site.
- 2) In accordance with a periodic time frame determined by the NYSDEC, the owner shall periodically certify, in writing, that all Institutional Controls set forth in a(n) Environmental Easement remain in place and continue to be complied with. The owner shall provide a written certification to the RP, upon the RP’s request, in order to allow the RP to include the certification in the site’s Periodic Review Report (PRR) certification to the NYSDEC.
- 3) In the event the site is delisted, the owner remains bound by the Environmental Easement and shall submit, upon request by the NYSDEC, a written certification that the Environmental Easement is still in place and has been complied with.
- 4) The owner shall grant access to the site to the RP and the NYSDEC and its agents for the purposes of performing activities required under the SMP and assuring compliance with the SMP.
- 5) The owner is responsible for assuring the security of the remedial components located on its property to the best of its ability. In the event that damage to the remedial components or

vandalism is evident, the owner shall notify the site's RP and the NYSDEC in accordance with the timeframes indicated in Section 1.3-Notifications.

- 6) In the event some action or inaction by the owner adversely impacts the site, the owner must notify the site's RP and the NYSDEC in accordance with the time frame indicated in Section 1.3- Notifications and (ii) coordinate the performance of necessary corrective actions with the RP.
- 7) The owner must notify the RP and the NYSDEC of any change in ownership of the site property (identifying the tax map numbers in any correspondence) and provide contact information for the new owner of the site properties. 6 NYCRR Part contains notification requirements applicable to any construction or activity changes and changes in ownership. Among the notification requirements is the following: Sixty days prior written notification must be made to the NYSDEC. Notification is to be submitted to the NYSDEC Division of Environmental Remediation's Site Control Section. Notification requirements for a change in use are detailed in Section 2.4 of the SMP. A 60-Day Advance Notification Form and Instructions are found at <http://www.dec.ny.gov/chemical/76250.html>.
- 8) In accordance with the tenant notification law, within 15 days of receipt, the owner must supply a copy of any vapor intrusion data, that is produced with respect to structures and that exceeds NYSDOH or OSHA guidelines on the site, whether produced by the NYSDEC, RP, or owner, to the tenants on the property. The owner must otherwise comply with the tenant and occupant notification provisions of Environmental Conservation Law Article 27, Title 24.

### **Remedial Party Responsibilities**

- 1) The RP must follow the SMP provisions regarding any construction and/or excavation it undertakes at the site.
- 2) The RP shall report to the NYSDEC all activities required for remediation, operation, maintenance, monitoring, and reporting. Such reporting includes, but is not limited to, periodic review reports and certifications, electronic data deliverables, corrective action work plans and reports, and updated SMPs.
- 3) Before accessing the site property to undertake a specific activity, the RP shall provide the owner advance notification that shall include an explanation of the work expected to be completed. The RP shall provide to (i) the owner, upon the owner's request, (ii) the NYSDEC, and (iii) other entities, if required by the SMP, a copy of any data generated during the site visit and/or any final report produced.
- 4) If the NYSDEC determines that an update of the SMP is necessary, the RP shall update the SMP and obtain final approval from the NYSDEC. Within 5 business days after NYSDEC approval, the RP shall submit a copy of the approved SMP to the owner(s).
- 5) The RP shall notify the NYSDEC and the owner of any changes in RP ownership and/or control and of any changes in the party/entity responsible for the operation, maintenance, and monitoring of and reporting. The RP shall provide contact information for the new party/entity. Such activity constitutes a Change of Use pursuant to 375-1.11(d) and requires 60-days prior notice to the NYSDEC. A 60-Day Advance Notification Form and Instructions are found at <http://www.dec.ny.gov/chemical/76250.html>.

- 6) The RP shall notify the NYSDEC of any damage to or modification of the systems as required under Section 1.3- Notifications of the SMP.
- 7) Prior to a change in use that impacts the remedial system or requirements and/or responsibilities for implementing the SMP, the RP shall submit to the NYSDEC for approval an amended SMP.
- 8) Any change in use, change in ownership, change in site classification (*e.g.*, delisting), reduction or expansion of remediation, and other significant changes related to the site may result in a change in responsibilities and, therefore, necessitate an update to the SMP and/or updated legal documents. The RP shall contact the Department to discuss the need to update such documents.

Change in RP ownership and/or control and/or site ownership does not affect the RP's obligations with respect to the site unless a legally binding document executed by the NYSDEC releases the RP of its obligations.

Future site owners and RPs and their successors and assigns are required to carry out the activities set forth above.

**APPENDIX D**

Site Specific Boring Logs



ROUX ASSOCIATES, INC.  
Environmental Consulting  
& Management

209 Shafter Street  
Islandia, NY 11749  
Telephone: (631) 232-2600  
Fax: (631) 232-9898

# WELL CONSTRUCTION LOG

WELL NO. <b>RXMW-1</b>	NORTHING <b>236040.391</b>	EASTING <b>1014369.914</b>
PROJECT NO./NAME <b>2611.0002Y002 / Spofford Avenue</b>		LOCATION <b>1221 Spofford Avenue</b>
APPROVED BY <b>J. Wills</b>	LOGGED BY <b>Rachel Miller</b>	<b>Bronx, New York</b>
DRILLING CONTRACTOR/DRILLER <b>Aquifer Drilling and Testing / German H.</b>		GEOGRAPHIC AREA <b>Tiffany Street Sidewalk</b>
DRILL BIT DIAMETER/TYPE <b>4" / Drive Sampler</b>	BOREHOLE DIAMETER <b>4-inches</b>	DRILLING EQUIPMENT/METHOD <b>8140LC / Rotosonic</b>
CASING MAT./DIA. <b>PVC / 2-inch</b>	SCREEN: <b>TYPE Slotted</b>	SAMPLING METHOD <b>Sonic Core</b>
ELEVATION OF: GROUND SURFACE (Feet)		START-FINISH DATE <b>6/15/18-6/15/18</b>
TOP OF WELL CASING <b>34.91</b>		TOTAL LENGTH <b>10.0ft</b>
TOP & BOTTOM SCREEN <b>/</b>		DIA. <b>2-inch</b>
GRAVEL PACK SIZES <b>Morie #2</b>		SLOT SIZE <b>20-slot</b>

Depth, feet	Graphic Log	Visual Description	Blow Counts per 6"	PID Values (ppm)	REMARKS
0		CONCRETE.		0.0	Hand cleared to 5 ft bls.
0		Dark brown, medium to coarse SAND, some fine Sand, little Silt, trace gravel; dry.		0.0	Sample RXMW-1_0-2 collected for TCL VOCs, TCL SVOCs, Pesticides, Herbicides, TAL Metals, Hex Chromium, PCBs, and Total Cyanide.
0		Light brown, fine to medium SAND and SILT, some medium to coarse Sand, trace clay and gravel; dry.		0.0	
5		Light brown, medium to coarse SAND and SILT, little Clay, trace gravel; moist.		0.2	Sample RXMW-1_7-11 collected for TCL VOCs, TCL SVOCs, Pesticides, Herbicides, TAL Metals, Hex Chromium, PCBs, and Total Cyanide.
5		Light grey, fine to medium SAND and WEATHERED BEDROCK, trace cobble; moist.		0.0	
10		Grey, BEDROCK; wet.			Bedrock encountered at 9 ft bls.
10					
15					End of boring 15 ft bls.

BORING/FEET 2611.0002Y002.GPJ ROUX.GDT 7/3/18



ROUX ASSOCIATES, INC.  
Environmental Consulting  
& Management

209 Shafter Street  
Islandia, NY 11749  
Telephone: (631) 232-2600  
Fax: (631) 232-9898

Page 1 of 1

# WELL CONSTRUCTION LOG

WELL NO. <b>RXMW-2</b>	NORTHING <b>235940.279</b>	EASTING <b>1014390.293</b>
PROJECT NO./NAME <b>2611.0002Y002 / Spofford Avenue</b>		LOCATION <b>1221 Spofford Avenue</b>
APPROVED BY <b>J. Wills</b>	LOGGED BY <b>Rachel Miller</b>	<b>Bronx, New York</b>
DRILLING CONTRACTOR/DRILLER <b>Aquifer Drilling and Testing / German H.</b>		GEOGRAPHIC AREA <b>Tiffany Street Sidewalk</b>
DRILL BIT DIAMETER/TYPE <b>4" / Drive Sampler</b>	BOREHOLE DIAMETER <b>4-inches</b>	DRILLING EQUIPMENT/METHOD <b>8140LC / Rotosonic</b>
CASING MAT./DIA. <b>PVC / 2-inch</b>	SCREEN: <b>TYPE Slotted</b>	SAMPLING METHOD <b>Sonic Core</b>
ELEVATION OF: (Feet)	GROUND SURFACE <b>32.09</b>	TOP OF WELL CASING <b>TOP &amp; BOTTOM SCREEN</b>
		TOTAL LENGTH <b>10.0ft</b>
		DIA. <b>2-inch</b>
		SLOT SIZE <b>20-slot</b>
		GRAVEL PACK SIZES <b>Morie #2</b>

Depth, feet	Graphic Log	Visual Description	Blow Counts per 6"	PID Values (ppm)	REMARKS
0	Concrete.	CONCRETE.		0.0	Hand cleared to 5 ft bls.
0	Grout.	Dark brown, medium to coarse SAND, some fine Sand, little Silt, trace gravel; dry.		0.0	Sample RXMW-2_0-2 collected for TCL VOCs, TCL SVOCs, Pesticides, Herbicides, TAL Metals, Hex Chromium, PCBs, and Total Cyanide.
5	Bentonite pellets.	Light brown, medium to coarse SAND and SILT, some fine Sand, little Gravel, trace Clay; dry.		0.0	
10	Morie #2 sand.	Light brown, medium to coarse SAND and SILT, some fine Sand, little Gravel, trace Clay; moist.		0.0	
15	10' of 2-inch diameter, 0.020" slotted screen.	Light grey, medium to coarse SAND and WEATHERED BEDROCK, little cobbles; moist.		0.2	Sample RXMW-2_13-15 collected for TCL VOCs, TCL SVOCs, Pesticides, Herbicides, TAL Metals, Hex Chromium, PCBs, and Total Cyanide.
15		Grey, BEDROCK; wet.			Bedrock encountered at 15 ft bls.
20	Bottom of well.				End of boring 20 ft bls.

BORING/FEET 2611.0002Y002.GPJ ROUX.GDT 7/3/18



ROUX ASSOCIATES, INC.  
Environmental Consulting  
& Management

209 Shafter Street  
Islandia, NY 11749  
Telephone: (631) 232-2600  
Fax: (631) 232-9898

# WELL CONSTRUCTION LOG

WELL NO. <b>RXMW-3</b>	NORTHING <b>236050.062</b>	EASTING <b>1014667.432</b>
PROJECT NO./NAME <b>2611.0002Y002 / Spofford Avenue</b>		LOCATION <b>1221 Spofford Avenue</b>
APPROVED BY <b>J. Wills</b>	LOGGED BY <b>Rachel Miller</b>	<b>Bronx, New York</b>
DRILLING CONTRACTOR/DRILLER <b>Aquifer Drilling and Testing / Rob G.</b>		GEOGRAPHIC AREA <b>Former Boiler Room Basement (Wing F)</b>
DRILL BIT DIAMETER/TYPE <b>2" / Drive Sampler</b>	BOREHOLE DIAMETER <b>3-inches</b>	DRILLING EQUIPMENT/METHOD <b>420 / Geoprobe</b>
CASING MAT./DIA. <b>PVC / 2-inch</b>	SCREEN: <b>TYPE Slotted</b>	SAMPLING METHOD <b>2" Macro-Core</b>
ELEVATION OF: GROUND SURFACE (Feet) <b>29.48</b>		START-FINISH DATE <b>5/24/18-5/29/18</b>
TOP OF WELL CASING <b>29.48</b>		TOTAL LENGTH <b>7.0</b> ft
TOP & BOTTOM SCREEN <b>/</b>		DIA. <b>2-inch</b>
GRAVEL PACK SIZES <b>Morie #2</b>		SLOT SIZE <b>20-Slot</b>

Depth, feet	Graphic Log	Visual Description	Blow Counts per 6"	PID Values (ppm)	REMARKS
1		CONCRETE.			Sample RXMW-3 1-3 collected for TCL VOCs, TCL SVOCs, Pesticides, Herbicides, TAL Metals, Hex Chromium, PCBs, and Total Cyanide.
2		Dark brown to dark grey, fine SAND and SILT, some coarse Sand, little Gravel; wet.	1.9		Odor and staining observed in soil at approximately 1.5 ft bls.
3		Grey, BEDROCK; wet.			Bedrock encountered at 3 ft bls.
4					
5					
6					
7					
8	Bottom of well.				End of boring at 8 ft bls.

BORING/FEET 2611.0002Y002.GPJ ROUX.GDT 7/3/18





ROUX ASSOCIATES, INC.  
Environmental Consulting  
& Management

209 Shafter Street  
Islandia, NY 11749  
Telephone: (631) 232-2600  
Fax: (631) 232-9898

# WELL CONSTRUCTION LOG

WELL NO. <b>RXMW-4</b>	NORTHING <b>236005.467</b>	EASTING <b>1014676.725</b>
PROJECT NO./NAME <b>2611.0002Y002 / Spofford Avenue</b>		LOCATION <b>1221 Spofford Avenue</b>
APPROVED BY <b>J. Wills</b>	LOGGED BY <b>Ron Lombino</b>	<b>Bronx, New York</b>
DRILLING CONTRACTOR/DRILLER <b>Aquifer Drilling and Testing / Tony P.</b>		GEOGRAPHIC AREA <b>Southeast Courtyard</b>
DRILL BIT DIAMETER/TYPE <b>4" / Drive Sampler</b>	BOREHOLE DIAMETER <b>4-inches</b>	DRILLING EQUIPMENT/METHOD <b>8140LC / Rotosonic</b>
CASING MAT./DIA. <b>PVC / 2-inch</b>	SCREEN: <b>TYPE Slotted</b>	MAT. <b>PVC</b>
ELEVATION OF: GROUND SURFACE (Feet) <b>50.48</b>		TOTAL LENGTH <b>8.0</b> ft
TOP OF WELL CASING		DIA. <b>2-inch</b>
TOP & BOTTOM SCREEN		SAMPLING METHOD <b>Sonic Core</b>
GRAVEL PACK SIZES <b>Morie #2</b>		START-FINISH DATE <b>4/24/18-5/1/18</b>

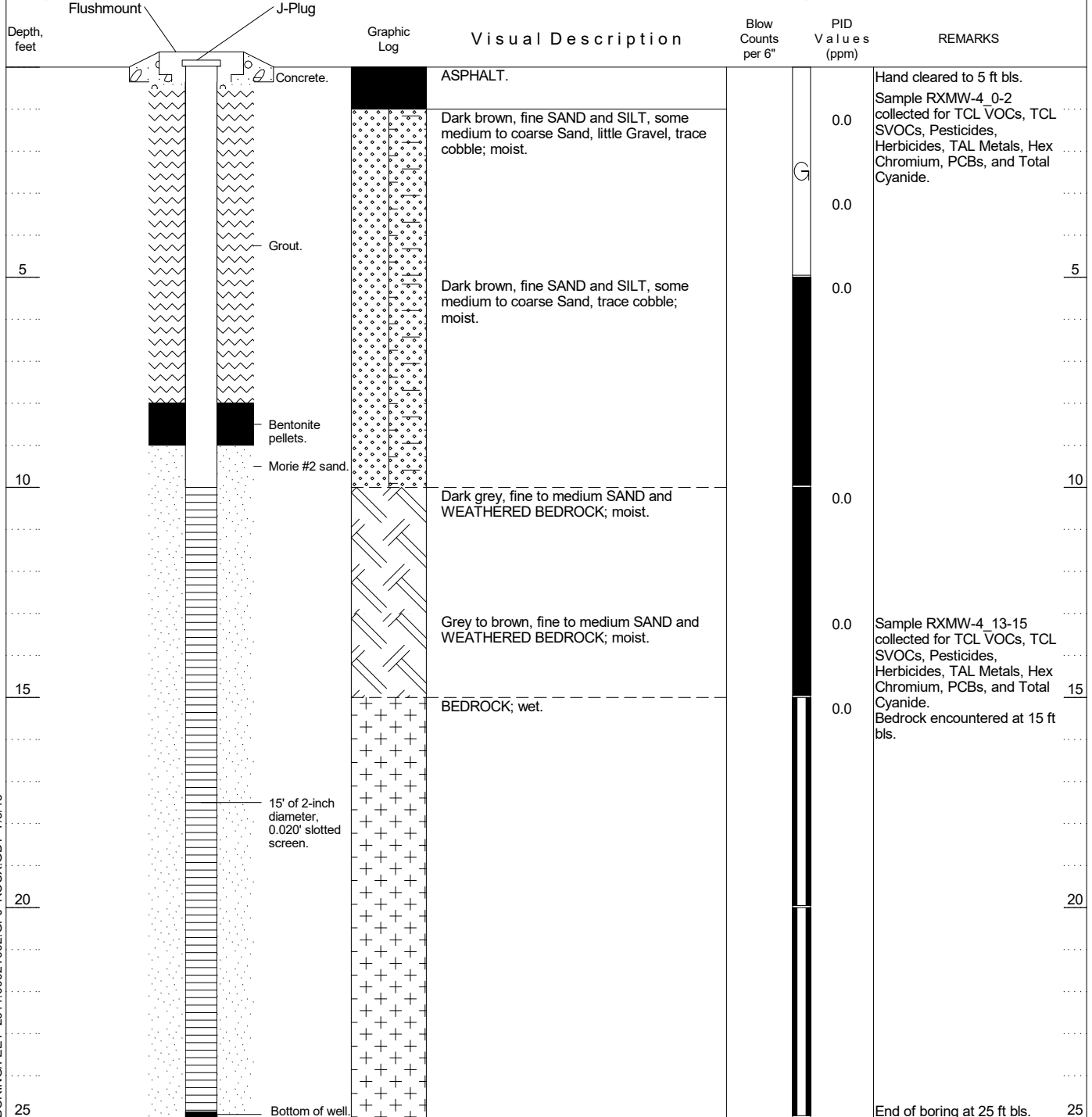

BORING/FEET 2611.0002Y002.GPJ ROUX.GDT 7/3/18



ROUX ASSOCIATES, INC.  
Environmental Consulting  
& Management

209 Shafter Street  
Islandia, NY 11749  
Telephone: (631) 232-2600  
Fax: (631) 232-9898

# WELL CONSTRUCTION LOG

WELL NO. <b>RXMW-5</b>	NORTHING <b>235954.481</b>	EASTING <b>1014711.047</b>
PROJECT NO./NAME <b>2611.0002Y002 / Spofford Avenue</b>		LOCATION <b>1221 Spofford Avenue</b>
APPROVED BY <b>J. Wills</b>	LOGGED BY <b>L. Sugano</b>	<b>Bronx, New York</b>
DRILLING CONTRACTOR/DRILLER <b>Aquifer Drilling and Testing / Tony P.</b>		GEOGRAPHIC AREA <b>Southeast Courtyard</b>
DRILL BIT DIAMETER/TYPE <b>4" / Drive Sampler</b>	BOREHOLE DIAMETER <b>4-inches</b>	DRILLING EQUIPMENT/METHOD <b>8140LC / Rotosonic</b>
CASING MAT./DIA. <b>PVC / 2-inch</b>	SCREEN: <b>TYPE Slotted</b>	MAT. <b>PVC</b>
ELEVATION OF: (Feet)		TOTAL LENGTH <b>10.0ft</b>
GROUND SURFACE	TOP OF WELL CASING <b>50.37</b>	TOP & BOTTOM SCREEN <b>/</b>
GRAVEL PACK SIZES <b>Morie #2</b>		DIA. <b>2-inch</b>
		SLOT SIZE <b>20-slot</b>

Depth, feet	Graphic Log	Visual Description	Blow Counts per 6"	PID Values (ppm)	REMARKS
0	Flushmount Concrete.	ASPHALT.		0.0	Hand cleared to 5 ft bls.
0		Grey, medium to coarse SAND and GRAVEL, some fine Sand and Silt, trace cobble (fill); moist.		0.0	Sample RXMW-5_0-2 collected for TCL VOCs, TCL SVOCs, Pesticides, Herbicides, TAL Metals, Hex Chromium, PCBs, and Total Cyanide.
0		Dark brown, fine SAND and SILT, some Gravel, little Cobble and Brick, trace medium to coarse Sand (fill); moist.		0.0	
5	Grout.	Dark brown, fine SAND and SILT, some medium to coarse Sand, trace gravel and brick (fill); moist.		0.0	
10	Bentonite pellets. Morie #2 sand	Brown, fine to medium SAND and WEATHERED BEDROCK; moist.		0.0	
15	10' of 2-inch diameter, 0.020" slotted screen.	Grey, BEDROCK; wet.		0.0	Sample RXMW-5_12-14 collected for TCL VOCs, TCL SVOCs, Pesticides, Herbicides, TAL Metals, Hex Chromium, PCBs, and Total Cyanide. Bedrock encountered at 14 ft bls.
20	Bottom of well				End of boring at 20 ft bls.

BORING/FEET 2611.0002Y002.GPJ ROUX.GDT 7/3/18



ROUX ASSOCIATES, INC.  
Environmental Consulting  
& Management

209 Shafter Street  
Islandia, NY 11749  
Telephone: (631) 232-2600  
Fax: (631) 232-9898

# WELL CONSTRUCTION LOG

WELL NO. <b>RXMW-6</b>	NORTHING <b>235938.248</b>	EASTING <b>1014802.507</b>
PROJECT NO./NAME <b>2611.0002Y002 / Spofford Avenue</b>		LOCATION <b>1221 Spofford Avenue</b>
APPROVED BY <b>J. Wills</b>	LOGGED BY <b>L. Sugano</b>	<b>Bronx, New York</b>
DRILLING CONTRACTOR/DRILLER <b>Aquifer Drilling and Testing / Tony P.</b>		GEOGRAPHIC AREA <b>Southeast Courtyard</b>
DRILL BIT DIAMETER/TYPE <b>4" / Drive Sampler</b>	BOREHOLE DIAMETER <b>4-inches</b>	DRILLING EQUIPMENT/METHOD <b>8140LC / Rotosonic</b>
CASING MAT./DIA. <b>PVC / 2-inch</b>	SCREEN: <b>TYPE Slotted</b>	MAT. <b>PVC</b>
TOTAL LENGTH <b>10.0ft</b>		DIA. <b>2-inch</b>
SLOT SIZE <b>20-slot</b>		
ELEVATION OF: (Feet)	GROUND SURFACE <b>50.52</b>	TOP OF WELL CASING <b>/</b>
TOP & BOTTOM SCREEN <b>/</b>		GRAVEL PACK SIZES <b>Morie #2</b>

Depth, feet	Flushmount	J-Plug	Graphic Log	Visual Description	Blow Counts per 6"	PID Values (ppm)	REMARKS
			Concrete.	ASPHALT.			Hand cleared to 5 ft bls.
			Grout.	Dark brown, fine SAND and SILT, some medium to coarse Sand, little Brick, trace wood and cobble (fill); wet.		0.0	Sample RXMW-6_0-2 collected for TCL VOCs, TCL SVOCs, Pesticides, Herbicides, TAL Metals, Hex Chromium, PCBs, and Total Cyanide. Perched water observed at approximately 1 ft bls.
			Bentonite pellets.	Brown, fine SAND and SILT, some Gravel, trace cobble (fill); wet.		0.0	
5			Morie #2 sand.	Brown to grey, fine SAND and SILT, some medium to coarse Sand, little Gravel, trace brick (fill); moist.		0.0	
				Brown, fine to medium SAND and WEATHERED BEDROCK; moist.		0.0	
10				Grey, fine to medium SAND and WEATHERED BEDROCK; moist.		0.0	Sample RXMW-6_9-11 collected for TCL VOCs, TCL SVOCs, Pesticides, Herbicides, TAL Metals, Hex Chromium, PCBs, and Total Cyanide.
			10' of 2-inch diameter, 0.020" slotted screen.	Grey, BEDROCK; wet.			Bedrock encountered at 11 ft bls.
15			Bottom of well.				End of boring at 16 ft bls.

BORING/FEET 2611.0002Y002.GPJ ROUX.GDT 7/3/18



ROUX ASSOCIATES, INC.  
Environmental Consulting  
& Management

209 Shafter Street  
Islandia, NY 11749  
Telephone: (631) 232-2600  
Fax: (631) 232-9898

# WELL CONSTRUCTION LOG

WELL NO. <b>RXMW-7</b>	NORTHING <b>236006.039</b>	EASTING <b>1014809.493</b>
PROJECT NO./NAME <b>2611.0002Y002 / Spofford Avenue</b>		LOCATION <b>1221 Spofford Avenue</b>
APPROVED BY <b>J. Wills</b>	LOGGED BY <b>Rachel Miller</b>	<b>Bronx, New York</b>
DRILLING CONTRACTOR/DRILLER <b>Aquifer Drilling and Testing / German H.</b>		GEOGRAPHIC AREA <b>Southeast Courtyard</b>
DRILL BIT DIAMETER/TYPE <b>4" / Drive Sampler</b>	BOREHOLE DIAMETER <b>4-inches</b>	DRILLING EQUIPMENT/METHOD <b>8140LC / Rotosonic</b>
CASING MAT./DIA. <b>PVC / 2-inch</b>	SCREEN: <b>TYPE Slotted</b>	MAT. <b>PVC</b>
TOTAL LENGTH <b>10.0ft</b>		DIA. <b>2-inch</b>
ELEVATION OF: GROUND SURFACE		START-FINISH DATE <b>6/14/18-6/15/18</b>
(Feet)	TOP OF WELL CASING <b>50.71</b>	TOP & BOTTOM SCREEN <b>/</b>
GRAVEL PACK SIZES <b>Morie #2</b>		

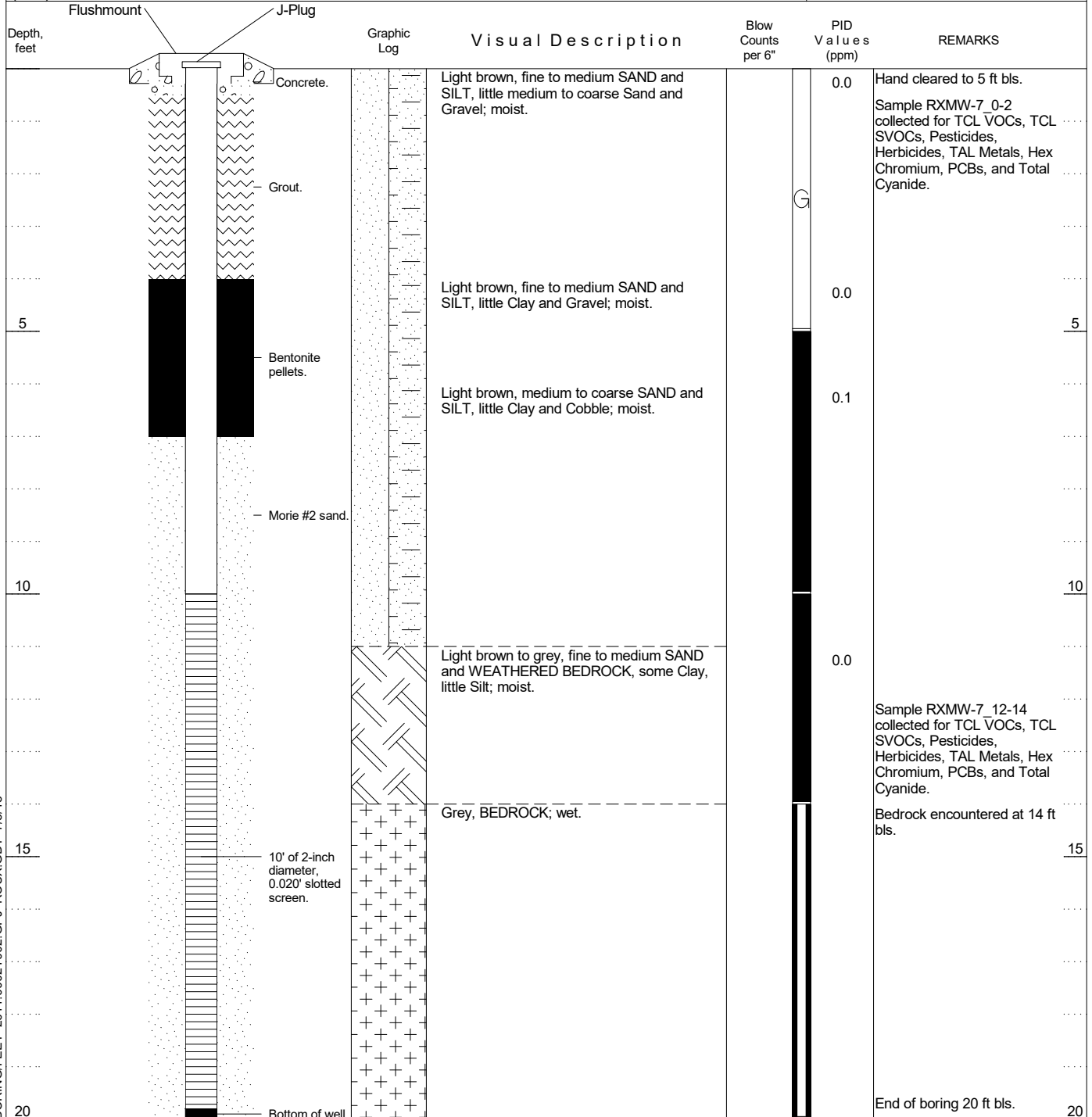

BORING/FEET 2611.0002Y002.GPJ ROUX.GDT 7/9/18



ROUX ASSOCIATES, INC.  
Environmental Consulting  
& Management

209 Shafter Street  
Islandia, NY 11749  
Telephone: (631) 232-2600  
Fax: (631) 232-9898

# WELL CONSTRUCTION LOG

WELL NO. <b>RXMW-8</b>	NORTHING <b>236049.926</b>	EASTING <b>1014756.752</b>
PROJECT NO./NAME <b>2611.0002Y002 / Spofford Avenue</b>		LOCATION <b>1221 Spofford Avenue</b>
APPROVED BY <b>J. Wills</b>	LOGGED BY <b>Rachel Miller</b>	<b>Bronx, New York</b>
DRILLING CONTRACTOR/DRILLER <b>Aquifer Drilling and Testing / Rob G.</b>		GEOGRAPHIC AREA <b>Former Laundry Room (Wing F)</b>
DRILL BIT DIAMETER/TYPE <b>2" / Drive Sampler</b>	BOREHOLE DIAMETER <b>3-inches</b>	DRILLING EQUIPMENT/METHOD <b>420 / Geoprobe</b>
CASING MAT./DIA. <b>PVC / 2-inch</b>	SCREEN: <b>TYPE Slotted</b>	MAT. <b>PVC</b>
TOTAL LENGTH <b>8.0</b> ft		DIA. <b>2-inch</b>
SLOT SIZE <b>20-slot</b>		
ELEVATION OF: (Feet)	GROUND SURFACE <b>44.01</b>	TOP OF WELL CASING <b>/</b>
TOP & BOTTOM SCREEN <b>/</b>		GRAVEL PACK SIZES <b>Morie #2</b>

Depth, feet	Flushmount	J-Plug	Graphic Log	Visual Description	Blow Counts per 6"	PID Values (ppm)	REMARKS
			Concrete.	CONCRETE.			
				Dark brown, fine SAND and SILT, some medium to coarse Sand, little Gravel; dry.		0.1	Sample RXMW-8_1-3 collected for TCL VOCs, TCL SVOCs, Pesticides, Herbicides, TAL Metals, Hex Chromium, PCBs, and Total Cyanide.
5			Grout.				
			Bentonite pellets.				
			Morie #2 sand.	Light brown, fine SAND and SILT, some medium to coarse Sand; moist.		0.1	
10				Grey, medium to coarse SAND, some Gravel, little fine Sand; wet.		1.7	Sample RXMW-8_9-11 collected for TCL VOCs, TCL SVOCs, Pesticides, Herbicides, TAL Metals, Hex Chromium, PCBs, and Total Cyanide.
				Grey, BEDROCK; wet.			Bedrock encountered at 11 ft bls.
15			8' of 2-inch diameter, 0.020' slotted screen.				
			Bottom of well.				End of boring 17 ft bls.

BORING/FEET 2611.0002Y002.GPJ ROUX.GDT 7/9/18



ROUX ASSOCIATES, INC.  
Environmental Consulting  
& Management

209 Shafter Street  
Islandia, NY 11749  
Telephone: (631) 232-2600  
Fax: (631) 232-9898

# WELL CONSTRUCTION LOG

WELL NO. <b>RXMW-9</b>	NORTHING <b>236110.801</b>	EASTING <b>1014579.727</b>
PROJECT NO./NAME <b>2611.0002Y002 / Spofford Avenue</b>		LOCATION <b>1221 Spofford Avenue</b>
APPROVED BY <b>J. Wills</b>	LOGGED BY <b>Ron Lombino</b>	<b>Bronx, New York</b>
DRILLING CONTRACTOR/DRILLER <b>Aquifer Drilling and Testing / Tony P.</b>		GEOGRAPHIC AREA <b>Northwest Courtyard</b>
DRILL BIT DIAMETER/TYPE <b>4" / Drive Sampler</b>	BOREHOLE DIAMETER <b>4-inches</b>	DRILLING EQUIPMENT/METHOD <b>8140LC / Rotosonic</b>
CASING MAT./DIA. <b>PVC / 2-inch</b>	SCREEN: <b>TYPE Slotted</b>	MAT. <b>PVC</b>
ELEVATION OF: GROUND SURFACE		TOTAL LENGTH <b>8.0 ft</b>
(Feet)	TOP OF WELL CASING <b>58.21</b>	TOP & BOTTOM SCREEN <b>/</b>
GRAVEL PACK SIZES <b>Morie #2</b>		DIA. <b>2-inch</b> SLOT SIZE <b>20-slot</b>

Depth, feet	Graphic Log	Visual Description	Blow Counts per 6"	PID Values (ppm)	REMARKS
0	Flushmount J-Plug Concrete. Grout.	ASPHALT.			Hand cleared to 5 ft bls.
1		Dark to light grey, fine to coarse SAND, some Gravel, little Silt; moist.			Sample RXMW-9_0-2 collected for TCL VOCs, TCL SVOCs, Pesticides, Herbicides, TAL Metals, Hex Chromium, PCBs, and Total Cyanide. ...1
2	Bentonite pellets.	Dark brown, fine SAND and SILT, some medium to coarse Sand and Gravel, little Cobble; moist.		0.0	...2
3					...3
4	Morie #2 sand.			0.0	...4
5					...5
6				0.0	Sample RXMW-9_5-7 collected for TCL VOCs, TCL SVOCs, Pesticides, Herbicides, TAL Metals, Hex Chromium, PCBs, and Total Cyanide. ...6
7		Grey, fine to medium SAND and WEATHERED BEDROCK; moist.			...7
8	8' of 2-inch diameter, 0.020" slotted screen.	Grey, BEDROCK; wet.		0.0	Bedrock encountered at 7.5 ft bls. ...8
9					...9
10					...10
11					...11
12	Bottom of well.				End of boring at 12 ft bls. ...12

BORING/FEET 2611.0002Y002.GPJ ROUX.GDT 7/8/18



ROUX ASSOCIATES, INC.  
Environmental Consulting  
& Management

209 Shafter Street  
Islandia, NY 11749  
Telephone: (631) 232-2600  
Fax: (631) 232-9898

# WELL CONSTRUCTION LOG

WELL NO. <b>RXMW-10</b>	NORTHING <b>236169.224</b>	EASTING <b>1014436.137</b>
PROJECT NO./NAME <b>2611.0002Y002 / Spofford Avenue</b>		LOCATION <b>1221 Spofford Avenue</b>
APPROVED BY <b>J. Wills</b>	LOGGED BY <b>Ron Lombino</b>	<b>Bronx, New York</b>
DRILLING CONTRACTOR/DRILLER <b>Aquifer Drilling and Testing / Tony P.</b>		GEOGRAPHIC AREA <b>Northwest Courtyard</b>
DRILL BIT DIAMETER/TYPE <b>4" / Drive Sampler</b>	BOREHOLE DIAMETER <b>4-inches</b>	DRILLING EQUIPMENT/METHOD <b>8140LC / Rotosonic</b>
CASING MAT./DIA. <b>PVC / 2-inch</b>	SCREEN: <b>TYPE Slotted</b>	MAT. <b>PVC</b>
ELEVATION OF: (Feet)		TOTAL LENGTH <b>8.0</b> ft
GROUND SURFACE	TOP OF WELL CASING <b>58.48</b>	TOP & BOTTOM SCREEN <b>/</b>
GRAVEL PACK SIZES <b>Morie #2</b>		DIA. <b>2-inch</b> SLOT SIZE <b>20-slot</b>

Depth, feet	Graphic Log	Visual Description	Blow Counts per 6"	PID Values (ppm)	REMARKS
0	Flushmount J-Plug Concrete.	ASPHALT.		0.0	Hand cleared to 5 ft bls.
1	Bentonite pellets.	CONCRETE.		0.0	Sample RXMW-10_0-2 collected for TCL VOCs, TCL SVOCs, Pesticides, Herbicides, TAL Metals, Hex Chromium, PCBs, and Total Cyanide.
2	Morie #2 sand.	Dark brown, fine SAND and SILT, some Gravel, little medium to coarse Sand, trace brick (fill); moist.		0.0	Sample RXMW-10_2-4 collected for TCL VOCs, TCL SVOCs, Pesticides, Herbicides, TAL Metals, Hex Chromium, PCBs, and Total Cyanide.
3		Dark brown, fine SAND and SILT, some Gravel, little medium to coarse Sand, trace cobble; moist.		0.0	
4		Bedrock encountered at 5 ft bls.			
5		Grey, BEDROCK, wet.		0.0	
6	8' of 2-inch diameter, 0.020' slotted screen.				
7					
8					
9					
10	Bottom of well.				End of boring 10 ft bls.

BORING/FEET 2611.0002Y002.GPJ ROUX.GDT 7/9/18



ROUX ASSOCIATES, INC.  
Environmental Consulting  
& Management

209 Shafter Street  
Islandia, NY 11749  
Telephone: (631) 232-2600  
Fax: (631) 232-9898

# WELL CONSTRUCTION LOG

WELL NO. <b>RXMW-11</b>	NORTHING <b>235951.167</b>	EASTING <b>1014554.65</b>
PROJECT NO./NAME <b>2611.0002Y002 / Spofford Avenue</b>		LOCATION <b>1221 Spofford Avenue</b>
APPROVED BY <b>J. Wills</b>	LOGGED BY <b>Ron Lombino</b>	<b>Bronx, New York</b>
DRILLING CONTRACTOR/DRILLER <b>Aquifer Drilling and Testing / Tony P.</b>		GEOGRAPHIC AREA <b>Southwest Courtyard</b>
DRILL BIT DIAMETER/TYPE <b>4" / Drive Sampler</b>	BOREHOLE DIAMETER <b>4-inches</b>	DRILLING EQUIPMENT/METHOD <b>8140LC / Rotosonic</b>
CASING MAT./DIA. <b>PVC / 2-inch</b>	SCREEN: <b>TYPE Slotted</b>	MAT. <b>PVC</b>
ELEVATION OF: (Feet)		TOTAL LENGTH <b>12.0ft</b>
GROUND SURFACE	TOP OF WELL CASING <b>34.33</b>	TOP & BOTTOM SCREEN <b>/</b>
GRAVEL PACK SIZES <b>Morie #2</b>		DIA. <b>2-inch</b>
SLOT SIZE <b>20-slot</b>		

Depth, feet	Graphic Log	Visual Description	Blow Counts per 6"	PID Values (ppm)	REMARKS
0	Flushmount Concrete.	ASPHALT.			Hand cleared to 5 ft bls.
0	Grout.	Light grey, fine to coarse SAND, some Gravel, little Silt and Cobble; dry.		0.0	Sample RXMW-11_0-2 collected for TCL VOCs, TCL SVOCs, Pesticides, Herbicides, TAL Metals, Hex Chromium, PCBs, and Total Cyanide.
5	Bentonite pellets.	Dark grey to reddish brown, fine to medium SAND and WEATHERED BEDROCK; moist.		0.0	
5	Morie #2 sand.	Light to dark grey, fine to medium SAND and WEATHERED BEDROCK; moist.		0.0	
10	12' of 2-inch diameter, 0.020" slotted screen.			0.0	Sample RXMW-11_11-13 collected for TCL VOCs, TCL SVOCs, Pesticides, Herbicides, TAL Metals, Hex Chromium, PCBs, and Total Cyanide.
15		Grey, BEDROCK; wet.		0.0	Bedrock encountered at 15 ft bls.
20	Bottom of well.				End of boring at 20 ft bls.

BORING/FEET 2611.0002Y002.GPJ ROUX.GDT 7/9/18





ROUX ASSOCIATES, INC.  
Environmental Consulting  
& Management

209 Shafter Street  
Islandia, NY 11749  
Telephone: (631) 232-2600  
Fax: (631) 232-9898

### SOIL BORING LOG

WELL NO. <b>RXSB-3A</b>	NORTHING <b>236146.957</b>	EASTING <b>1014659.927</b>
PROJECT NO./NAME <b>2611.0002Y002 / Spofford Avenue</b>		LOCATION <b>1221 Spofford Avenue</b>
APPROVED BY <b>J. Wills</b>	LOGGED BY <b>Rachel Miller</b>	<b>Bronx, New York</b>
DRILLING CONTRACTOR/DRILLER <b>Aquifer Drilling and Testing / Rob G.</b>		GEOGRAPHIC AREA <b>Northeast Courtyard</b>
DRILL BIT DIAMETER/TYPE <b>4" / Hand Auger</b>	BOREHOLE DIAMETER <b>4-inches</b>	DRILLING EQUIPMENT/METHOD <b>/ Hand Auger</b>
LAND SURFACE ELEVATION <b>56.51(FT.)</b>	DEPTH TO WATER <b>Not Measured</b>	SAMPLING METHOD <b>4" Hand Auger</b>
		START-FINISH DATE <b>5/22/18-5/22/18</b>
		BACKFILL <b>Soil Cuttings</b>

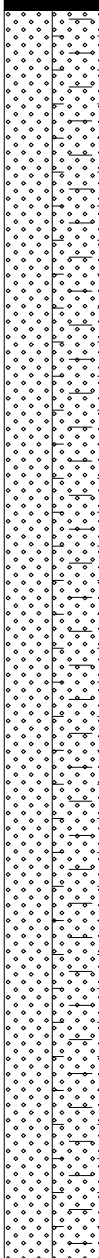
Depth, feet	Graphic Log	Visual Description	Blow Counts per 6"	PID Values (ppm)	REMARKS
		ASPHALT.		0.3	
1		Dark brown, fine SAND and SILT, some medium to coarse Sand, little Gravel, trace cobble; moist.			Sample RXSB-3A_0-2 collected for TAL Metals.
2				0.2	Sample RXSB-3A_2-4 collected for TAL Metals.
3			G		
4				0.2	Sample RXSB-3A_4-6 collected for TAL Metals.
5					
6					End of boring at 6 ft bls.

BORING/FEET 2611.0002Y002.GPJ ROUX.GDT 7/3/18



ROUX ASSOCIATES, INC.  
Environmental Consulting  
& Management

209 Shafter Street  
Islandia, NY 11749  
Telephone: (631) 232-2600  
Fax: (631) 232-9898

# SOIL BORING LOG

WELL NO. <b>RXSB-3AE</b>	NORTHING <b>236156.88</b>	EASTING <b>1014665.488</b>
PROJECT NO./NAME <b>2611.0002Y002 / Spofford Avenue</b>		LOCATION <b>1221 Spofford Avenue</b>
APPROVED BY <b>J. Wills</b>	LOGGED BY <b>Rachel Miller</b>	<b>Bronx, New York</b>
DRILLING CONTRACTOR/DRILLER <b>Aquifer Drilling and Testing / Rob G.</b>		GEOGRAPHIC AREA <b>Northeast Courtyard</b>
DRILL BIT DIAMETER/TYPE <b>4" / Hand Auger</b>	BOREHOLE DIAMETER <b>4-inches</b>	DRILLING EQUIPMENT/METHOD <b>/ Hand Auger</b>
LAND SURFACE ELEVATION <b>56.62(FT.)</b>	DEPTH TO WATER <b>Not Measured</b>	SAMPLING METHOD <b>4" Hand Auger</b>
		START-FINISH DATE <b>5/22/18-5/22/18</b>
		BACKFILL <b>Soil Cuttings</b>

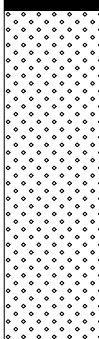
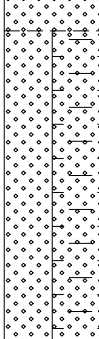
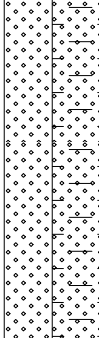
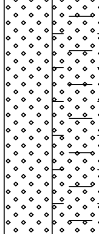
Depth, feet	Graphic Log	Visual Description	Blow Counts per 6"	PID Values (ppm)	REMARKS
		ASPHALT.		0.5	
1		Dark brown, fine SAND, some medium to coarse Sand, trace gravel; moist.			Sample RXSB-3AE_0-2 collected for TAL Metals.
2		Light brown, fine SAND and SILT, some medium to coarse Sand, trace gravel; moist.		0.4	Sample RXSB-3AE_2-4 collected for TAL Metals.
3			G		
4		Light brown, fine SAND and SILT, some medium to coarse Sand, little fine Clay, trace gravel; moist.		0.3	Sample RXSB-3AE_4-6 collected for TAL Metals.
5					
6					End of boring at 6 ft bls.

BORING/FEET 2611.0002Y002.GPJ ROUX.GDT 7/9/18



ROUX ASSOCIATES, INC.  
Environmental Consulting  
& Management

209 Shafter Street  
Islandia, NY 11749  
Telephone: (631) 232-2600  
Fax: (631) 232-9898

# SOIL BORING LOG

WELL NO. <b>RXSB-3AN</b>	NORTHING <b>236158.633</b>	EASTING <b>1014657.319</b>
PROJECT NO./NAME <b>2611.0002Y002 / Spofford Avenue</b>		LOCATION <b>1221 Spofford Avenue</b>
APPROVED BY <b>J. Wills</b>	LOGGED BY <b>Rachel Miller</b>	<b>Bronx, New York</b>
DRILLING CONTRACTOR/DRILLER <b>Aquifer Drilling and Testing / Rob G.</b>		GEOGRAPHIC AREA <b>Northeast Courtyard</b>
DRILL BIT DIAMETER/TYPE <b>4" / Hand Auger</b>	BOREHOLE DIAMETER <b>4-inches</b>	DRILLING EQUIPMENT/METHOD <b>/ Hand Auger</b>
LAND SURFACE ELEVATION <b>56.67(FT.)</b>	DEPTH TO WATER <b>Not Measured</b>	SAMPLING METHOD <b>4" Hand Auger</b>
		START-FINISH DATE <b>5/22/18-5/22/18</b>
		BACKFILL <b>Soil Cuttings</b>

Depth, feet	Graphic Log	Visual Description	Blow Counts per 6"	PID Values (ppm)	REMARKS
	[Redacted]	ASPHALT.			
1	[Dotted pattern]	Dark brown, fine SAND and SILT, some fine to medium Sand, little coarse Sand, trace gravel; moist.		0.4	Sample RXSB-3AN_0-2 collected for TAL Metals.
2	[Dotted pattern]	Dark brown to reddish brown, fine SAND and SILT, some medium to coarse Sand, trace gravel; moist.		0.3	Sample RXSB-3AN_2-4 collected for TAL Metals.
3	[Dotted pattern]		G		
4	[Dotted pattern]	Light brown, fine SAND and SILT, little medium to coarse Sand, trace clay and gravel; moist.		0.1	Sample RXSB-3AN_4-6 collected for TAL Metals.
5	[Dotted pattern]				
6	[Dotted pattern]				End of boring at 6 ft bls.

BORING/FEET 2611.0002Y002.GPJ ROUX.GDT 7/8/18



ROUX ASSOCIATES, INC.  
Environmental Consulting  
& Management

209 Shafter Street  
Islandia, NY 11749  
Telephone: (631) 232-2600  
Fax: (631) 232-9898

# SOIL BORING LOG

WELL NO. <b>RXSB-3AS</b>	NORTHING <b>236132.386</b>	EASTING <b>1014661.622</b>
PROJECT NO./NAME <b>2611.0002Y002 / Spofford Avenue</b>		LOCATION <b>1221 Spofford Avenue</b>
APPROVED BY <b>J. Wills</b>	LOGGED BY <b>Rachel Miller</b>	<b>Bronx, New York</b>
DRILLING CONTRACTOR/DRILLER <b>Aquifer Drilling and Testing / Rob G.</b>		GEOGRAPHIC AREA <b>Northeast Courtyard</b>
DRILL BIT DIAMETER/TYPE <b>4" / Hand Auger</b>	BOREHOLE DIAMETER <b>4-inches</b>	DRILLING EQUIPMENT/METHOD <b>/ Hand Auger</b>
LAND SURFACE ELEVATION <b>56.57(FT.)</b>	DEPTH TO WATER <b>Not Measured</b>	SAMPLING METHOD <b>4" Hand Auger</b>
		START-FINISH DATE <b>5/22/18-5/22/18</b>
		BACKFILL <b>Soil Cuttings</b>

Depth, feet	Graphic Log	Visual Description	Blow Counts per 6"	PID Values (ppm)	REMARKS
	[Solid Black]	ASPHALT.		0.2	
1	[Dotted Pattern]	Dark brown, fine SAND and SILT, some medium to coarse Sand, trace gravel; moist.			Sample RXSB-3AS_0-2 collected for TAL Metals.
2	[Dotted Pattern]			0.2	Sample RXSB-3AS_2-4 collected for TAL Metals.
3	[Dotted Pattern]		G		
4	[Dotted Pattern]	Light brown, fine SAND and SILT, little medium to coarse Sand, trace clay and gravel; moist.		0.0	Sample RXSB-3AS_4-6 collected for TAL Metals.
5	[Dotted Pattern]				
6	[Dotted Pattern]				End of boring at 6 ft bls.

BORING/FEET 2611.0002Y002.GPJ ROUX.GDT 7/8/18



ROUX ASSOCIATES, INC.  
Environmental Consulting  
& Management

209 Shafter Street  
Islandia, NY 11749  
Telephone: (631) 232-2600  
Fax: (631) 232-9898

# SOIL BORING LOG

WELL NO. <b>RXSB-3AW</b>	NORTHING <b>236152.153</b>	EASTING <b>1014648.226</b>
PROJECT NO./NAME <b>2611.0002Y002 / Spofford Avenue</b>		LOCATION <b>1221 Spofford Avenue</b>
APPROVED BY <b>J. Wills</b>	LOGGED BY <b>Rachel Miller</b>	<b>Bronx, New York</b>
DRILLING CONTRACTOR/DRILLER <b>Aquifer Drilling and Testing / Rob G.</b>		GEOGRAPHIC AREA <b>Northeast Courtyard</b>
DRILL BIT DIAMETER/TYPE <b>4" / Hand Auger</b>	BOREHOLE DIAMETER <b>4-inches</b>	DRILLING EQUIPMENT/METHOD <b>/ Hand Auger</b>
LAND SURFACE ELEVATION <b>56.75(FT.)</b>	DEPTH TO WATER <b>Not Measured</b>	SAMPLING METHOD <b>4" Hand Auger</b>
		START-FINISH DATE <b>5/22/18-5/22/18</b>
		BACKFILL <b>Soil Cuttings</b>

Depth, feet	Graphic Log	Visual Description	Blow Counts per 6"	PID Values (ppm)	REMARKS
		ASPHALT.		0.2	
1		Dark brown, fine SAND and SILT, some medium to coarse Sand, trace gravel; moist.			Sample RXSB-3AW_0-2 collected for TAL Metals.
2		Light brown, fine SAND and SILT, some medium to coarse Sand, trace gravel; moist.		0.2	Sample RXSB-3AW_2-4 collected for TAL Metals.
3			G		
4		Light brown to reddish brown, fine SAND and SILT, some medium to coarse Sand, trace gravel; moist.		0.2	Sample RXSB-3AW_4-6 collected for TAL Metals.
5					
6					End of boring at 6 ft bls.

BORING/FEET 2611.0002Y002.GPJ ROUX.GDT 7/3/18



ROUX ASSOCIATES, INC.  
Environmental Consulting  
& Management

209 Shafter Street  
Islandia, NY 11749  
Telephone: (631) 232-2600  
Fax: (631) 232-9898

# SOIL BORING LOG

WELL NO. <b>RXSB-11/RXSV-9</b>	NORTHING <b>236127.932</b>	EASTING <b>1014439.082</b>
PROJECT NO./NAME <b>2611.0002Y002 / Spofford Avenue</b>		LOCATION <b>1221 Spofford Avenue</b>
APPROVED BY <b>J. Wills</b>	LOGGED BY <b>Ron Lombino</b>	<b>Bronx, New York</b>
DRILLING CONTRACTOR/DRILLER <b>Aquifer Drilling and Testing / Tony P.</b>		GEOGRAPHIC AREA <b>Northwest Courtyard</b>
DRILL BIT DIAMETER/TYPE <b>2" / Drive Sampler</b>	BOREHOLE DIAMETER <b>2-inches</b>	DRILLING EQUIPMENT/METHOD <b>78226T / Geoprobe</b>
LAND SURFACE ELEVATION <b>58.71(FT.)</b>	DEPTH TO WATER <b>Not Measured</b>	SAMPLING METHOD <b>2" Macro-Core</b>
		START-FINISH DATE <b>4/23/18-4/23/18</b>
		BACKFILL <b>Soil Cuttings</b>

Depth, feet	Graphic Log	Visual Description	Blow Counts per 6"	PID Values (ppm)	REMARKS
		ASPHALT.			Hand cleared to 5 ft bls.
0.0				0.0	
1.0		Dark grey, fine to coarse SAND, some Gravel, little Silt; dry.		0.0	Sample RXSB-11_0-2 collected for TCL VOCs, TCL SVOCs, Pesticides, Herbicides, TAL Metals, Hex Chromium, PCBs, and Total Cyanide.
1.5		Dark brown, fine SAND and SILT, some Gravel, trace cobble; moist.		0.0	
2.0					
3.0					
3.5				0.0	Sample RXSB-11_3-5 collected for TCL VOCs, TCL SVOCs, Pesticides, Herbicides, TAL Metals, Hex Chromium, PCBs, and Total Cyanide.
4.0					Soil vapor point, RXSV-9, installed at 4 ft bls.
5.0					
					Bedrock at 5.5 ft bls.

BORING/FEET 2611.0002Y002.GPJ ROUX.GDT 7/9/18











ROUX ASSOCIATES, INC.  
Environmental Consulting  
& Management

209 Shafter Street  
Islandia, NY 11749  
Telephone: (631) 232-2600  
Fax: (631) 232-9898

# SOIL BORING LOG

WELL NO. <b>RXSB-12</b>	NORTHING <b>236100.328</b>	EASTING <b>1014507.534</b>
PROJECT NO./NAME <b>2611.0002Y002 / Spofford Avenue</b>		LOCATION <b>1221 Spofford Avenue</b>
APPROVED BY <b>J. Wills</b>	LOGGED BY <b>Ron Lombino</b>	<b>Bronx, New York</b>
DRILLING CONTRACTOR/DRILLER <b>Aquifer Drilling and Testing / Tony P.</b>		GEOGRAPHIC AREA <b>Northwest Courtyard</b>
DRILL BIT DIAMETER/TYPE <b>2" / Drive Sampler</b>	BOREHOLE DIAMETER <b>2-inches</b>	DRILLING EQUIPMENT/METHOD <b>78226T / Geoprobe</b>
LAND SURFACE ELEVATION <b>58.64(FT.)</b>	DEPTH TO WATER <b>Not Measured</b>	SAMPLING METHOD <b>2" Macro-Core</b>
		START-FINISH DATE <b>4/23/18-4/23/18</b>
		BACKFILL <b>Soil Cuttings</b>

Depth, feet	Graphic Log	Visual Description	Blow Counts per 6"	PID Values (ppm)	REMARKS
		ASPHALT.		0.0	Hand cleared to 5 ft bls.
1		Light grey, fine to coarse SAND, some Gravel, little Silt; dry.		0.0	Sample RXSB-12_0-2 collected for TCL VOCs, TCL SVOCs, Pesticides, Herbicides, TAL Metals, Hex Chromium, PCBs, and Total Cyanide.
2		Dark brown, fine SAND, little medium Sand and Gravel, trace cobble and coarse sand; moist.		0.0	
3		Dark brown, fine SAND, little medium Sand and Gravel, trace cobble, coarse sand, and weathered rock; moist.	G	0.0	
4		Dark brown, fine SAND and SILT, some medium Sand, trace gravel; moist.		0.0	
5		Dark grey, fine to medium SAND and WEATHERED BEDROCK; moist.		0.0	Sample RXSB-12_6-8 collected for TCL VOCs, TCL SVOCs, Pesticides, Herbicides, TAL Metals, Hex Chromium, PCBs, and Total Cyanide.
6		Dark grey, fine to medium SAND and WEATHERED BEDROCK; moist.		0.0	
7		Dark grey, fine to medium SAND and WEATHERED BEDROCK; moist.		0.0	
8		Dark grey, fine to medium SAND and WEATHERED BEDROCK; moist.		0.0	
					Bedrock at 8.5 ft bls.

BORING/FEET 2611.0002Y002.GPJ ROUX.GDT 7/9/18



ROUX ASSOCIATES, INC.  
Environmental Consulting  
& Management

209 Shafter Street  
Islandia, NY 11749  
Telephone: (631) 232-2600  
Fax: (631) 232-9898

# SOIL BORING LOG

WELL NO. <b>RXSB-13/RXSV-8</b>	NORTHING <b>235918.902</b>	EASTING <b>1014455.098</b>
PROJECT NO./NAME <b>2611.0002Y002 / Spofford Avenue</b>		LOCATION <b>1221 Spofford Avenue</b>
APPROVED BY <b>J. Wills</b>	LOGGED BY <b>Ron Lombino</b>	<b>Bronx, New York</b>
DRILLING CONTRACTOR/DRILLER <b>Aquifer Drilling and Testing / Tony P.</b>		GEOGRAPHIC AREA <b>Southwest Courtyard</b>
DRILL BIT DIAMETER/TYPE <b>2" / Drive Sampler</b>	BOREHOLE DIAMETER <b>2-inches</b>	DRILLING EQUIPMENT/METHOD <b>78226T / Geoprobe</b>
LAND SURFACE ELEVATION <b>34.82(FT.)</b>	DEPTH TO WATER <b>Not Measured</b>	SAMPLING METHOD <b>2" Macro-Core</b>
		START-FINISH DATE <b>4/24/18-4/26/18</b>
		BACKFILL <b>Soil Cuttings</b>

Depth, feet	Graphic Log	Visual Description	Blow Counts per 6"	PID Values (ppm)	REMARKS
		ASPHALT.			Hand cleared to 5 ft bls.
		Light grey, coarse SAND and GRAVEL, some Cobble (fill); dry.			
		Dark brown, fine SAND and SILT, some medium to coarse Sand, little Brick (fill); moist.		0.0	Sample RXSB-13_0-2 collected for TCL VOCs, TCL SVOCs, Pesticides, Herbicides, TAL Metals, Hex Chromium, PCBs, and Total Cyanide. Perched water observed at approximately 1 ft bls.
		Dark brown, SILT, some fine Sand, trace gravel; moist.		0.0	
5		Dark brown, fine SAND and SILT, some medium to coarse Sand, little Gravel; moist.		0.0	
		Light grey, COBBLE; moist.			
		Dark brown, fine SAND, some Silt, little medium to coarse Sand, trace cobble and gravel; moist.			
10		Dark brown, fine to medium SAND, some coarse Sand, little Silt, trace gravel; wet.		0.0	Soil vapor point, RXSV-8, installed at 10 ft bls.
		Dark brown to gray, fine SAND, some medium to coarse Sand, little Silt, trace weathered rock; moist.			
		Dark grey, fine to medium SAND and WEATHERED BEDROCK; moist.			Sample RXSB-13_13-15 collected for TCL VOCs, TCL SVOCs, Pesticides, Herbicides, TAL Metals, Hex Chromium, PCBs, and Total Cyanide.
15				0.0	Bedrock at 16 ft bls.

BORING/FEET 2611.0002Y002.GPJ ROUX.GDT 7/3/18





ROUX ASSOCIATES, INC.  
Environmental Consulting  
& Management

209 Shafter Street  
Islandia, NY 11749  
Telephone: (631) 232-2600  
Fax: (631) 232-9898

# SOIL BORING LOG

WELL NO. <b>RXSB-14</b>	NORTHING <b>Not Measured</b>	EASTING <b>Not Measured</b>
PROJECT NO./NAME <b>2611.0002Y002 / Spofford Avenue</b>		LOCATION <b>1221 Spofford Avenue</b>
APPROVED BY <b>J. Wills</b>	LOGGED BY <b>Ron Lombino</b>	<b>Bronx, New York</b>
DRILLING CONTRACTOR/DRILLER <b>Aquifer Drilling and Testing / Tony P.</b>		GEOGRAPHIC AREA <b>Southwest Courtyard</b>
DRILL BIT DIAMETER/TYPE <b>2" / Drive Sampler</b>	BOREHOLE DIAMETER <b>2-inches</b>	DRILLING EQUIPMENT/METHOD <b>78226T / Geoprobe</b>
LAND SURFACE ELEVATION <b>Not Measured</b>	DEPTH TO WATER <b>Not Measured</b>	BACKFILL <b>Soil Cuttings</b>
		SAMPLING METHOD <b>2" Macro-Core</b>
		START-FINISH DATE <b>4/24/18-4/24/18</b>

Depth, feet	Graphic Log	Visual Description	Blow Counts per 6"	PID Values (ppm)	REMARKS
		ASPHALT.		0.0	Hand cleared to 5 ft bls.
1		Light to dark grey, coarse SAND and GRAVEL, some Cobble (fill); dry.		0.0	Sample RXSB-14_0-2 & DUP042418 collected for TCL VOCs, TCL SVOCs, Pesticides, Herbicides, TAL Metals, Hex Chromium, PCBs, and Total Cyanide.
2		Light brown, fine to medium SAND and WEATHERED BEDROCK; dry.		0.0	
3		Light grey, fine to medium SAND and WEATHERED BEDROCK; moist.		0.0	
4					
5					Bedrock at 5 ft bls.

BORING/FEET 2611.0002Y002.GPJ ROUX.GDT 7/9/18



ROUX ASSOCIATES, INC.  
Environmental Consulting  
& Management

209 Shafter Street  
Islandia, NY 11749  
Telephone: (631) 232-2600  
Fax: (631) 232-9898

# SOIL BORING LOG

WELL NO. <b>RXSB-15/RXSV-4</b>	NORTHING <b>236006.876</b>	EASTING <b>1014739.477</b>
PROJECT NO./NAME <b>2611.0002Y002 / Spofford Avenue</b>		LOCATION <b>1221 Spofford Avenue</b>
APPROVED BY <b>J. Wills</b>	LOGGED BY <b>Ron Lombino</b>	<b>Bronx, New York</b>
DRILLING CONTRACTOR/DRILLER <b>Aquifer Drilling and Testing / Tony P.</b>		GEOGRAPHIC AREA <b>Southeast Courtyard</b>
DRILL BIT DIAMETER/TYPE <b>4" / Drive Sampler</b>	BOREHOLE DIAMETER <b>4-inches</b>	DRILLING EQUIPMENT/METHOD <b>8140LC / Rotosonic</b>
LAND SURFACE ELEVATION <b>51.00(FT.)</b>	DEPTH TO WATER <b>Not Measured</b>	SAMPLING METHOD <b>2" Macro-Core</b>
		START-FINISH DATE <b>4/26/18-4/26/18</b>
		BACKFILL <b>Soil Cuttings</b>

Depth, feet	Graphic Log	Visual Description	Blow Counts per 6"	PID Values (ppm)	REMARKS
		ASPHALT		0.0	Hand cleared to 5 ft bls.
1		Gray, medium to coarse SAND and GRAVEL, some fine Sand and Silt, little Cobble (fill); dry.		0.0	Sample RXSB-15_0-2 collected for TCL VOCs, TCL SVOCs, Pesticides, Herbicides, TAL Metals, Hex Chromium, PCBs, and Total Cyanide.
2		Brown, fine SAND and SILT, some Gravel, little Cobble, trace brick (fill); moist.		0.0	
3				0.0	
4				0.0	
5		Grey, fine to medium SAND and WEATHERED BEDROCK; moist.		0.0	
6				0.0	Sample RXSB-15_6-8 collected for TCL VOCs, TCL SVOCs, Pesticides, Herbicides, TAL Metals, Hex Chromium, PCBs, and Total Cyanide. Soil vapor point, RXSV-4, installed at 7 ft bls.
7				0.0	
8		Grey, BEDROCK; moist.		0.0	Bedrock at 8 ft bls.
9				0.0	
10				0.0	Bottom of boring at 10 ft bls.

BORING/FEET 2611.0002Y002.GPJ ROUX.GDT 7/9/18



ROUX ASSOCIATES, INC.  
Environmental Consulting  
& Management

209 Shafter Street  
Islandia, NY 11749  
Telephone: (631) 232-2600  
Fax: (631) 232-9898

# SOIL BORING LOG

WELL NO. <b>RXSB-16</b>	NORTHING <b>236067.495</b>	EASTING <b>1014752.943</b>		
PROJECT NO./NAME <b>2611.0002Y002 / Spofford Avenue</b>		LOCATION <b>1221 Spofford Avenue</b>		
APPROVED BY <b>J. Wills</b>	LOGGED BY <b>Rachel Miller</b>	<b>Bronx, New York</b>		
DRILLING CONTRACTOR/DRILLER <b>Aquifer Drilling and Testing / Rob G.</b>		GEOGRAPHIC AREA <b>Former Laundry Room (Wing F)</b>		
DRILL BIT DIAMETER/TYPE <b>2" / Drive Sampler</b>	BOREHOLE DIAMETER <b>3-inches</b>	DRILLING EQUIPMENT/METHOD <b>420 / Geoprobe</b>	SAMPLING METHOD <b>2" Macro-Core</b>	START-FINISH DATE <b>5/24/18-5/29/18</b>
LAND SURFACE ELEVATION <b>42.70(FT.)</b>	DEPTH TO WATER <b>Not Measured</b>	BACKFILL <b>Soil Cuttings</b>		

Depth, feet	Graphic Log	Visual Description	Blow Counts per 6"	PID Values (ppm)	REMARKS
1		CONCRETE.			
1		Dark brown to dark grey, fine SAND, some medium to coarse Sand, trace brick (fill); dry.		6.4	Dark stained soil observed on soil at 1 ft bls. Sample RXSB-16_1-3 collected for TCL VOCs, TCL SVOCs, Pesticides, Herbicides, TAL Metals, Hex Chromium, PCBs, and Total Cyanide.
2					
3				2.6	
4					
5					
6		Dark grey, fine SAND and SILT, some medium to coarse Sand and Weathered Bedrock; moist.		4.7	
7					
8					
9				2.5	Sample RXSB-16_9-11 collected for TCL VOCs, TCL SVOCs, Pesticides, Herbicides, TAL Metals, Hex Chromium, PCBs, and Total Cyanide.
10					
11					Bedrock at 11 ft bls.

BORING/FEET 2611.0002Y002.GPJ ROUX.GDT 7/9/18



ROUX ASSOCIATES, INC.  
Environmental Consulting  
& Management

209 Shafter Street  
Islandia, NY 11749  
Telephone: (631) 232-2600  
Fax: (631) 232-9898

### SOIL BORING LOG

WELL NO. <b>RXSB-17/RXSV-7</b>	NORTHING <b>236108.297</b>	EASTING <b>1014667.266</b>
PROJECT NO./NAME <b>2611.0002Y002 / Spofford Avenue</b>		LOCATION <b>1221 Spofford Avenue</b>
APPROVED BY <b>J. Wills</b>	LOGGED BY <b>Rachel Miller</b>	<b>Bronx, New York</b>
DRILLING CONTRACTOR/DRILLER <b>Aquifer Drilling and Testing / Rob G.</b>		GEOGRAPHIC AREA <b>Northeast Courtyard</b>
DRILL BIT DIAMETER/TYPE <b>4" / Hand Auger</b>	BOREHOLE DIAMETER <b>4-inches</b>	DRILLING EQUIPMENT/METHOD <b>/ Hand Auger</b>
LAND SURFACE ELEVATION <b>56.31(FT.)</b>	DEPTH TO WATER <b>Not Measured</b>	BACKFILL <b>Soil Cuttings</b>
SAMPLING METHOD <b>4" Hand Auger</b>		
START-FINISH DATE <b>5/23/18-5/23/18</b>		

Depth, feet	Graphic Log	Visual Description	Blow Counts per 6"	PID Values (ppm)	REMARKS
1		Dark brown, fine to medium SAND, little fine Silt and Gravel; moist.		7.5	Hand cleared to 5 ft bls. Sample RXSB-17_0-2 & DUP05232108 collected for TCL VOCs, TCL SVOCs, Pesticides, Herbicides, TAL Metals, Hex Chromium, PCBs, and Total Cyanide.
2		Dark brown, fine SAND and SILT, some medium to coarse Sand, little Gravel; moist.		5.8	
3					
4		Light brown, fine SAND and SILT, some medium to coarse Sand, little Gravel; moist.		0.0	
5					Sample RXSB-17_5-7 collected for TCL VOCs, TCL SVOCs, Pesticides, Herbicides, TAL Metals, Hex Chromium, PCBs, and Total Cyanide.
6		Light brown, fine SAND and SILT, some medium to coarse Sand, little Clay, trace gravel and cobbles; moist.		0.0	Soil vapor point, RXSV-7, installed at 6 ft bls.
7					Bedrock at 7 ft bls.

BORING/FEET 2611.0002Y002.GPJ ROUX.GDT 7/3/18



ROUX ASSOCIATES, INC.  
Environmental Consulting  
& Management

209 Shafter Street  
Islandia, NY 11749  
Telephone: (631) 232-2600  
Fax: (631) 232-9898

## SOIL BORING LOG

WELL NO. <b>RXTGW-12</b>	NORTHING <b>236188.723</b>	EASTING <b>1014776.812</b>		
PROJECT NO./NAME <b>2611.0002Y002 / Spofford Avenue</b>		LOCATION <b>1221 Spofford Avenue</b>		
APPROVED BY <b>J. Wills</b>	LOGGED BY <b>Rachel Miller</b>	<b>Bronx, New York</b>		
DRILLING CONTRACTOR/DRILLER <b>Aquifer Drilling and Testing / Rob G.</b>		GEOGRAPHIC AREA <b>Northeast Courtyard</b>		
DRILL BIT DIAMETER/TYPE <b>4" / Hand Auger</b>	BOREHOLE DIAMETER <b>4-inches</b>	DRILLING EQUIPMENT/METHOD <b>/ Hand Auger</b>	SAMPLING METHOD <b>4" Hand Auger</b>	START-FINISH DATE <b>5/24/18-5/24/18</b>
LAND SURFACE ELEVATION <b>56.73(FT.)</b>	DEPTH TO WATER <b>Not Measured</b>	BACKFILL <b>Soil Cuttings</b>		

Depth, feet	Graphic Log	Visual Description	Blow Counts per 6"	PID Values (ppm)	REMARKS
1		Dark brown, fine SAND and SILT, some medium to coarse Sand and medium Silt, trace gravel; wet.		1.2	Hand cleared to 5 ft bls. Sample RXTGW-12_0-2 collected for TCL VOCs, TCL SVOCs, Pesticides, Herbicides, TAL Metals, Hex Chromium, PCBs, and Total Cyanide.
2		Light brown, fine SAND and SILT, some medium to coarse Sand, trace clay and gravel; moist.		3.6	
3				G	
4				10.7	Sample RXTGW-12_4-6 & MS/MSD collected for TCL VOCs, TCL SVOCs, Pesticides, Herbicides, TAL Metals, Hex Chromium, PCBs, and Total Cyanide.
5					
6					Bedrock at 6 ft bls.

BORING/FEET 2611.0002Y002.GPJ ROUX.GDT 7/3/18





**ROUX ASSOCIATES, INC.**  
Environmental Consulting  
& Management

209 Shafter Street  
Islandia, NY 11749  
Telephone: (631) 232-2600  
Fax: (631) 232-9898

# SOIL BORING LOG

WELL NO. <b>1A10</b>	LATITUDE <b>235896.1951</b>	LONGITUDE <b>1014427.34</b>
PROJECT NO./NAME <b>2611.0002Y000 / Spofford Ave</b>		LOCATION <b>1221 Spofford Avenue</b>
APPROVED BY <b>L. Dolginko</b>	LOGGED BY <b>M. Todaro</b>	<b>Bronx, New York</b>
DRILLING CONTRACTOR/DRILLER <b>Russo Demolition / Excavator</b>		GEOGRAPHIC AREA <b>Building 1A</b>
DRILL BIT DIAMETER/TYPE <b>/ Excavator Bucket</b>	BOREHOLE DIAMETER	DRILLING EQUIPMENT/METHOD <b>Excavator / Test Pit</b>
LAND SURFACE ELEVATION <b>34.78(FT. ABOVE NAVD 83)</b>	DEPTH TO WATER <b>Not Measured</b>	SAMPLING METHOD <b>Test Pit</b>
		START-FINISH DATE <b>11/21/18-11/21/18</b>
		BACKFILL <b>Soil Cuttings</b>

Depth, feet	Graphic Log	Visual Description	Blow Counts per 6"	PID Values (ppm)	REMARKS
		Brown, fine to medium SAND, some Gravel, Cobble, and Silt, little Brick and Concrete (fill); moist.		0.1	Collect sample 1A10 (0-1) for TCL VOCs and NJEPH.
		Brown, fine to medium SAND, some Silt, little Gravel, Cobble, Brick, and Concrete (fill); moist.		0.1	Collect sample 1A10 (0-5) for TCL SVOCs, TCL Pesticides, Herbicides, PCBs, TAL Metals, Mercury, Hex/Tri Chromium, Total Cyanide, and RCRA Characteristics.
		Brown to grey, fine to medium SAND, some Silt, little Gravel, Cobble, Brick, and Concrete (fill); moist.		0.1	
5					
		Brown, fine to medium SAND, some Silt and Gravel, little Cobble; moist.			
10				0.1	
15		Grey, WEATHERED BEDROCK; moist.			
		Grey, WEATHERED BEDROCK; wet.			
					Bedrock encountered at 19 ft bls.

BORING/FEET 2611.0002Y000.GPJ ROUX.GDT 4/16/20



**ROUX ASSOCIATES, INC.**  
Environmental Consulting  
& Management

209 Shafter Street  
Islandia, NY 11749  
Telephone: (631) 232-2600  
Fax: (631) 232-9898

## SOIL BORING LOG

WELL NO. <b>1A11</b>	LATITUDE <b>235908.5638</b>	LONGITUDE <b>1014549.937</b>	
PROJECT NO./NAME <b>2611.0002Y000 / Spofford Ave</b>		LOCATION <b>1221 Spofford Avenue</b>	
APPROVED BY <b>L. Dolginko</b>	LOGGED BY <b>C. Wygel</b>	<b>Bronx, New York</b>	
DRILLING CONTRACTOR/DRILLER <b>Russo Demolition / Excavator</b>		GEOGRAPHIC AREA <b>Building 1A</b>	
DRILL BIT DIAMETER/TYPE <b>/ Excavator Bucket</b>	BOREHOLE DIAMETER	DRILLING EQUIPMENT/METHOD <b>Excavator / Test Pit</b>	SAMPLING METHOD <b>Test Pit</b>
LAND SURFACE ELEVATION <b>34.28 (FT. ABOVE NAVD 83)</b>	DEPTH TO WATER <b>Not Measured</b>	BACKFILL <b>Soil Cuttings</b>	

Depth, feet	Graphic Log	Visual Description	Blow Counts per 6"	PID Values (ppm)	REMARKS
1		Brown, medium to coarse SAND, some Silt, Clay, and coarse Gravel, trace cobble, brick, asphalt, and concrete (fill); moist.			Collect sample 1A11 (0-5) for TCL SVOCs, TCL Pesticides, Herbicides, PCBs, TAL Metals, Mercury, Hex/Tri Chromium, Total Cyanide, and RCRA Characteristics. <span style="float: right;">1</span>
2		Brown, fine to medium SAND, some Silt, little coarse Gravel, trace brick, asphalt, concrete, and cobble (fill); moist.			Collect sample 1A11 (1-2) for TCL VOCs and NJEPH. <span style="float: right;">2</span>
3		Light brown, fine to medium SAND, some Silt, little coarse Gravel, trace cobble; moist.			<span style="float: right;">3</span>
4					<span style="float: right;">4</span>
5		Grey, CLAY; moist.			<span style="float: right;">5</span>
6		Lithology not noted.			<span style="float: right;">6</span>
7				G	<span style="float: right;">7</span>
8					<span style="float: right;">8</span>
9					<span style="float: right;">9</span>
10					<span style="float: right;">10</span>
11					<span style="float: right;">11</span>
12					<span style="float: right;">12</span>
13					Bedrock encountered at 13 ft bls. <span style="float: right;">13</span>

BORING/FEET 2611.0002Y000.GPJ ROUX.GDT 4/16/20





**ROUX ASSOCIATES, INC.**  
Environmental Consulting  
& Management

209 Shafter Street  
Islandia, NY 11749  
Telephone: (631) 232-2600  
Fax: (631) 232-9898

## SOIL BORING LOG

WELL NO. <b>1A12</b>	LATITUDE <b>235929.0414</b>	LONGITUDE <b>1014613.435</b>	
PROJECT NO./NAME <b>2611.0002Y000 / Spofford Ave</b>		LOCATION <b>1221 Spofford Avenue</b>	
APPROVED BY <b>L. Dolginko</b>	LOGGED BY <b>C. Wygel</b>	<b>Bronx, New York</b>	
DRILLING CONTRACTOR/DRILLER <b>Russo Demolition / Excavator</b>		GEOGRAPHIC AREA <b>Building 1A</b>	
DRILL BIT DIAMETER/TYPE <b>/ Excavator Bucket</b>	BOREHOLE DIAMETER	DRILLING EQUIPMENT/METHOD <b>Excavator / Test Pit</b>	SAMPLING METHOD <b>Test Pit</b>
LAND SURFACE ELEVATION <b>34.75 (FT. ABOVE NAVD 83)</b>	DEPTH TO WATER <b>Not Measured</b>	BACKFILL <b>Soil Cuttings</b>	

Depth, feet	Graphic Log	Visual Description	Blow Counts per 6"	PID Values (ppm)	REMARKS
1		Grey to brown, fine to medium SAND and SILT, some Clay, Asphalt, Concrete, and Brick, little Cobble (fill); moist.		0.0	Collect sample 1A12 (0-1) for TCL VOCs and NJEPH.
2		Grey to brown, fine to medium SAND and SILT, some Clay, little Cobble, trace concrete, brick, and metal (fill); moist.		0.0	Collect sample 1A12 (0-5) for TCL SVOCs, TCL Pesticides, Herbicides, PCBs, TAL Metals, Mercury, Hex/Tri Chromium, Total Cyanide, and RCRA Characteristics.
3					
4					
5					
6		Lithology not noted.	G		
7					
8					
9					
10					
11					Bedrock encountered at 11.5 ft bls.

BORING/FEET 2611.0002Y000.GPJ ROUX.GDT 4/16/20





**ROUX ASSOCIATES, INC.**  
Environmental Consulting  
& Management

209 Shafter Street  
Islandia, NY 11749  
Telephone: (631) 232-2600  
Fax: (631) 232-9898

## SOIL BORING LOG

WELL NO. <b>1A3</b>	LATITUDE <b>236010.5733</b>	LONGITUDE <b>1014526.385</b>
PROJECT NO./NAME <b>2611.0002Y000 / Spofford Ave</b>		LOCATION <b>1221 Spofford Avenue</b>
APPROVED BY <b>L. Dolginko</b>	LOGGED BY <b>M. Todaro</b>	<b>Bronx, New York</b>
DRILLING CONTRACTOR/DRILLER <b>Russo Demolition / Excavator</b>		GEOGRAPHIC AREA <b>Building 1A</b>
DRILL BIT DIAMETER/TYPE <b>/ Excavator Bucket</b>	BOREHOLE DIAMETER	DRILLING EQUIPMENT/METHOD <b>Excavator / Test Pit</b>
LAND SURFACE ELEVATION <b>34.44 (FT. ABOVE NAVD 83)</b>	DEPTH TO WATER <b>Not Measured</b>	SAMPLING METHOD <b>Test Pit</b>
		START-FINISH DATE <b>11/21/18-11/21/18</b>
		BACKFILL <b>Soil Cuttings</b>

Depth, feet	Graphic Log	Visual Description	Blow Counts per 6"	PID Values (ppm)	REMARKS
1		Brown, fine to medium SAND, some medium Gravel, little Brick and Concrete (fill); moist.		0.1	Collect sample 1A3 (0-1) for TCL VOCs and NJEPH.
2					Collect sample 1A3 (0-5) for TCL SVOCs, TCL Pesticides, Herbicides, PCBs, TAL Metals, Mercury, Hex/Tri Chromium, Total Cyanide, and RCRA Characteristics.
3					
4					
5		Grey, WEATHERED BEDROCK, some fine to medium SAND, little fine Gravel; moist.	G		
6					
7					
8				0.1	Bedrock encountered at 8 ft bls.

BORING/FEET 2611.0002Y000.GPJ ROUX.GDT 4/16/20



**ROUX ASSOCIATES, INC.**  
Environmental Consulting  
& Management

209 Shafter Street  
Islandia, NY 11749  
Telephone: (631) 232-2600  
Fax: (631) 232-9898

## SOIL BORING LOG

WELL NO. <b>1A4</b>	LATITUDE <b>236026.6747</b>	LONGITUDE <b>1014598.259</b>
PROJECT NO./NAME <b>2611.0002Y000 / Spofford Ave</b>		LOCATION <b>1221 Spofford Avenue</b>
APPROVED BY <b>L. Dolginko</b>	LOGGED BY <b>C. Wygel</b>	<b>Bronx, New York</b>
DRILLING CONTRACTOR/DRILLER <b>Russo Demolition / Excavator</b>		GEOGRAPHIC AREA <b>Building 1A</b>
DRILL BIT DIAMETER/TYPE <b>/ Excavator Bucket</b>	BOREHOLE DIAMETER	DRILLING EQUIPMENT/METHOD <b>Excavator / Test Pit</b>
LAND SURFACE ELEVATION <b>34.68(FT. ABOVE NAVD 83)</b>	DEPTH TO WATER <b>Not Measured</b>	SAMPLING METHOD <b>Test Pit</b>
		START-FINISH DATE <b>11/20/18-11/20/18</b>
		BACKFILL <b>Soil Cuttings</b>

Depth, feet	Graphic Log	Visual Description	Blow Counts per 6"	PID Values (ppm)	REMARKS
1		Brown, fine to medium SAND, some Silt, little coarse Gravel, trace brick, concrete, and cobble (fill); moist.			Collect sample 1A4 (0-1) for TCL VOCs and NJEPH.
2		Brown, fine to medium SAND, some Silt, little coarse Gravel and Cobble; moist.	G		Collect sample 1A4 (0-4) for TCL SVOCs, TCL Pesticides, Herbicides, PCBs, TAL Metals, Mercury, Hex/Tri Chromium, Total Cyanide, and RCRA Characteristics.
3		Brown, fine to medium SAND, some Silt and coarse Gravel, little Cobble; moist.			
4					Bedrock encountered at 4 ft bls.

BORING/FEET 2611.0002Y000.GPJ ROUX.GDT 4/16/20





**ROUX ASSOCIATES, INC.**  
Environmental Consulting  
& Management

209 Shafter Street  
Islandia, NY 11749  
Telephone: (631) 232-2600  
Fax: (631) 232-9898

## SOIL BORING LOG

WELL NO. <b>1A6/1AC3</b>	LATITUDE <b>235924.5745</b>	LONGITUDE <b>1014449.343</b>		
PROJECT NO./NAME <b>2611.0002Y000 / Spofford Ave</b>		LOCATION <b>1221 Spofford Avenue</b>		
APPROVED BY <b>L. Dolginko</b>	LOGGED BY <b>M. Todaro</b>	<b>Bronx, New York</b>		
DRILLING CONTRACTOR/DRILLER <b>Russo Demolition / Excavator</b>		GEOGRAPHIC AREA <b>Building 1A</b>		
DRILL BIT DIAMETER/TYPE <b>/ Excavator Bucket</b>	BOREHOLE DIAMETER	DRILLING EQUIPMENT/METHOD <b>Excavator / Test Pit</b>	SAMPLING METHOD <b>Test Pit</b>	START-FINISH DATE <b>11/26/18-11/26/18</b>
LAND SURFACE ELEVATION <b>33.97(FT. ABOVE NAVD 83)</b>	DEPTH TO WATER <b>Not Measured</b>	BACKFILL <b>Soil Cuttings</b>		

Depth, feet	Graphic Log	Visual Description	Blow Counts per 6"	PID V a l u e s (ppm)	REMARKS
	△ △ △ △	Light brown, fine to medium SAND, some Clay, Silt, Gravel, and Cobble, little Brick, Metal, and Concrete (fill); moist.		0.1	Collect sample 1A6 (0-1) for TCL VOCs and NJEPH.
	△ △ △ △				Collect sample 1A6 (0-5) for TCL SVOCs, TCL Pesticides, Herbicides, PCBs, TAL Metals, Mercury, Hex/Tri Chromium, Total Cyanide, and RCRA Characteristics.
5	△ △ △ △	Light brown, fine to medium SAND, some Clay, little Silt and debris, trace brick and concrete (fill); moist.		0.1	Collect sample 1AC3 (5-6) for TCL VOCs and NJEPH.
	△ △ △ △				Collect sample 1AC3 (5-16) for TCL SVOCs, TCL Pesticides, Herbicides, PCBs, TAL Metals, Mercury, Hex/Tri Chromium, Total Cyanide, and RCRA Characteristics.
10	△ △ △ △		G		
	△ △ △ △			0.1	
15	△ △ △ △				
	△ △ △ △	Lithology not noted.		0.1	Collect sample RXSB13 (16-18) for TCL SVOCs, TCL Pesticides, Herbicides, PCBs, TAL Metals, Mercury, Hex/Tri Chromium, Total Cyanide, and RCRA Characteristics.
	△ △ △ △				Bedrock encountered at 19 ft bls.

BORING/FEET 2611.0002Y000.GPJ ROUX.GDT 4/16/20





**ROUX ASSOCIATES, INC.**  
Environmental Consulting  
& Management

209 Shafter Street  
Islandia, NY 11749  
Telephone: (631) 232-2600  
Fax: (631) 232-9898

## SOIL BORING LOG

WELL NO. <b>1A8</b>	LATITUDE <b>235979.4115</b>	LONGITUDE <b>1014580.502</b>	
PROJECT NO./NAME <b>2611.0002Y000 / Spofford Ave</b>		LOCATION <b>1221 Spofford Avenue</b>	
APPROVED BY <b>L. Dolginko</b>	LOGGED BY <b>C. Wygel</b>	<b>Bronx, New York</b>	
DRILLING CONTRACTOR/DRILLER <b>Russo Demolition / Excavator</b>		GEOGRAPHIC AREA <b>Building 1A</b>	
DRILL BIT DIAMETER/TYPE <b>/ Excavator Bucket</b>	BOREHOLE DIAMETER	DRILLING EQUIPMENT/METHOD <b>Excavator / Test Pit</b>	SAMPLING METHOD <b>Test Pit</b>
LAND SURFACE ELEVATION <b>34.49 (FT. ABOVE NAVD 83)</b>	DEPTH TO WATER <b>Not Measured</b>	BACKFILL <b>Soil Cuttings</b>	

Depth, feet	Graphic Log	Visual Description	Blow Counts per 6"	PID Values (ppm)	REMARKS
1		Grey to brown, fine to medium SAND and SILT, some Clay, coarse Gravel, Asphalt, Brick, Concrete, and Metal, little Cobble (fill); moist.		0.0	Collect sample 1A8 (0-5) for TCL SVOCs, TCL Pesticides, Herbicides, PCBs, TAL Metals, Mercury, Hex/Tri Chromium, Total Cyanide, and RCRA Characteristics.
2		Grey to brown, fine to medium SAND, some SILT and coarse Gravel, trace, brick, and concrete (fill); moist.		0.0	Collect sample 1A8 (1-2) for TCL VOCs and NJEPH.
3		Grey to brown, fine to medium SAND, some Silt and coarse Gravel, trace brick and cobble (fill); moist.		0.0	
4			G		
5					
6					
7		Lithology not noted.			
7					Bedrock encountered at 7 ft bls.

BORING/FEET 2611.0002Y000.GPJ ROUX.GDT 4/16/20





**ROUX ASSOCIATES, INC.**  
Environmental Consulting  
& Management

209 Shafter Street  
Islandia, NY 11749  
Telephone: (631) 232-2600  
Fax: (631) 232-9898

# SOIL BORING LOG

WELL NO. <b>1A9/1AC2</b>	LATITUDE <b>Not Measured</b>	LONGITUDE <b>Not Measured</b>
PROJECT NO./NAME <b>2611.0002Y000 / Spofford Ave</b>		LOCATION <b>1221 Spofford Avenue</b>
APPROVED BY <b>L. Dolginko</b>	LOGGED BY <b>M. Todaro</b>	<b>Bronx, New York</b>
DRILLING CONTRACTOR/DRILLER <b>Russo Demolition / Excavator</b>		GEOGRAPHIC AREA <b>Building 1A</b>
DRILL BIT DIAMETER/TYPE <b>/ Excavator Bucket</b>	BOREHOLE DIAMETER	DRILLING EQUIPMENT/METHOD <b>Excavator / Test Pit</b>
LAND SURFACE ELEVATION <b>33.30(FT. ABOVE NAVD 83)</b>	DEPTH TO WATER <b>Not Measured</b>	SAMPLING METHOD <b>Test Pit</b>
		START-FINISH DATE <b>11/21/18-11/21/18</b>
		BACKFILL <b>Soil Cuttings</b>

Depth, feet	Graphic Log	Visual Description	Blow Counts per 6"	PID Values (ppm)	REMARKS
		Brown, fine to medium SAND, some Gravel, Cobble, and Silt, little Brick and Concrete (fill); moist.		0.1	Collect sample 1A9 (0-1) for TCL VOCs and NJEPH.
		Brown, fine to medium SAND, some Silt, little Gravel, Cobble, Brick, and Concrete (fill); moist.		0.1	Collect sample 1A9 (0-5) for TCL SVOCs, TCL Pesticides, Herbicides, PCBs, TAL Metals, Mercury, Hex/Tri Chromium, Total Cyanide, and RCRA Characteristics.
		Brown to grey, fine to medium SAND, some Silt, little Gravel, Cobble, Brick, and Concrete (fill); moist.		0.1	
5					5
		Brown, fine to medium SAND, some Silt and Gravel, little Cobble; moist.			Collect sample 1AC2 (5-16) for TCL SVOCs, TCL Pesticides, Herbicides, PCBs, TAL Metals, Mercury, Hex/Tri Chromium, Total Cyanide, and RCRA Characteristics. Collect sample 1AC2 (6-7) for TCL VOCs and NJEPH.
10				0.1	10
15		Grey, WEATHERED BEDROCK; moist.			15
				0.0	
		Grey, WEATHERED BEDROCK; wet.			
20					Bedrock encountered at 20 ft bls. 20

BORING/FEET 2611.0002Y000.GPJ ROUX.GDT 4/16/20





**ROUX ASSOCIATES, INC.**  
Environmental Consulting  
& Management

209 Shafter Street  
Islandia, NY 11749  
Telephone: (631) 232-2600  
Fax: (631) 232-9898

## SOIL BORING LOG

WELL NO. <b>1B1</b>	LATITUDE <b>236139.376</b>	LONGITUDE <b>1014375.303</b>
PROJECT NO./NAME <b>2611.0002Y000 / Spofford Ave</b>		LOCATION <b>1221 Spofford Avenue</b>
APPROVED BY <b>L. Dolginko</b>	LOGGED BY <b>C. Wygel</b>	<b>Bronx, New York</b>
DRILLING CONTRACTOR/DRILLER <b>Russo Demolition / Excavator</b>		GEOGRAPHIC AREA <b>Building 1B</b>
DRILL BIT DIAMETER/TYPE <b>/ Excavator Bucket</b>	BOREHOLE DIAMETER	DRILLING EQUIPMENT/METHOD <b>Excavator / Test Pit</b>
LAND SURFACE ELEVATION <b>36.52(FT. ABOVE NAVD 83)</b>	DEPTH TO WATER <b>Not Measured</b>	SAMPLING METHOD <b>Test Pit</b>
		START-FINISH DATE <b>11/19/18-11/19/18</b>
		BACKFILL <b>Soil Cuttings</b>

Depth, feet	Graphic Log	Visual Description	Blow Counts per 6"	PID Values (ppm)	REMARKS
1		Brown to grey, medium to coarse SAND, some Silt, coarse Gravel, Crushed Concrete, and Asphalt (fill); moist.		0.2	Collect sample 1B1 (0-5.5) for TCL SVOCs, TCL Pesticides, Herbicides, PCBs, TAL Metals, Mercury, Hex/Tri Chromium, Total Cyanide, and RCRA Characteristics.
2		Brown, medium to coarse SAND, some Silt and coarse Gravel, little Concrete and Asphalt, trace cobble (fill); moist.		0.5	Collect sample 1B1 (1-2) for TCL VOCs and NJEPH.
3				0.4	
4			G	0.4	
5					
6		Lithology not noted.			
7					
8					Bedrock encountered at 8 ft bls.

BORING/FEET 2611.0002Y000.GPJ ROUX.GDT 4/16/20



**ROUX ASSOCIATES, INC.**  
*Environmental Consulting  
 & Management*

209 Shafter Street  
 Islandia, NY 11749  
 Telephone: (631) 232-2600  
 Fax: (631) 232-9898

## SOIL BORING LOG

WELL NO. <b>1B10</b>	LATITUDE <b>236089.8828</b>	LONGITUDE <b>1014522.37</b>		
PROJECT NO./NAME <b>2611.0002Y000 / Spofford Ave</b>		LOCATION <b>1221 Spofford Avenue</b>		
APPROVED BY <b>L. Dolginko</b>	LOGGED BY <b>C. Wygel</b>	<b>Bronx, New York</b>		
DRILLING CONTRACTOR/DRILLER <b>Russo Demolition / Excavator</b>		GEOGRAPHIC AREA <b>Building 1B</b>		
DRILL BIT DIAMETER/TYPE <b>/ Excavator Bucket</b>	BOREHOLE DIAMETER	DRILLING EQUIPMENT/METHOD <b>Excavator / Test Pit</b>	SAMPLING METHOD <b>Test Pit</b>	START-FINISH DATE <b>11/19/18-11/19/18</b>
LAND SURFACE ELEVATION <b>36.47(FT. ABOVE NAVD 83)</b>	DEPTH TO WATER <b>Not Measured</b>	BACKFILL <b>Soil Cuttings</b>		

Depth, feet	Graphic Log	Visual Description	Blow Counts per 6"	PID Values (ppm)	REMARKS
1		Grey to brown, medium to coarse SAND, some Silt, coarse Gravel, and Crushed Concrete, little Cobble, Brick, and Asphalt (fill); moist.		0.0	Collect sample 1B10 (0-5.5) for TCL SVOCs, TCL Pesticides, Herbicides, PCBs, TAL Metals, Mercury, Hex/Tri Chromium, Total Cyanide, and RCRA Characteristics..
2		Brown, medium to coarse SAND, some Silt and Weathered Bedrock; moist.		0.0	Collect sample 1B10 (1-2) for TCL VOCs and NJEPH.
3			G		
4					
5					
6					Bedrock encountered at 6 ft bls.

BORING/FEET 2611.0002Y000.GPJ ROUX.GDT 4/16/20







**ROUX ASSOCIATES, INC.**  
Environmental Consulting  
& Management

209 Shafter Street  
Islandia, NY 11749  
Telephone: (631) 232-2600  
Fax: (631) 232-9898

## SOIL BORING LOG

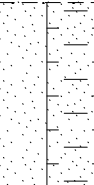
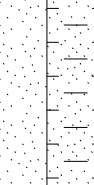
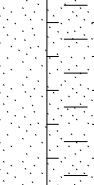
WELL NO. <b>1B2</b>	LATITUDE <b>236147.975</b>	LONGITUDE <b>1014412.581</b>
PROJECT NO./NAME <b>2611.0002Y000 / Spofford Ave</b>		LOCATION <b>1221 Spofford Avenue</b>
APPROVED BY <b>L. Dolginko</b>	LOGGED BY <b>C. Wygel</b>	<b>Bronx, New York</b>
DRILLING CONTRACTOR/DRILLER <b>Russo Demolition / Excavator</b>		GEOGRAPHIC AREA <b>Building 1B</b>
DRILL BIT DIAMETER/TYPE <b>/ Excavator Bucket</b>	BOREHOLE DIAMETER	DRILLING EQUIPMENT/METHOD <b>Excavator / Test Pit</b>
LAND SURFACE ELEVATION <b>36.71(F.T. ABOVE NAVD 83)</b>	DEPTH TO WATER <b>Not Measured</b>	SAMPLING METHOD <b>Test Pit</b>
		START-FINISH DATE <b>11/19/18-11/19/18</b>
		BACKFILL <b>Soil Cuttings</b>

Depth, feet	Graphic Log	Visual Description	Blow Counts per 6"	PID Values (ppm)	REMARKS
1		Grey to brown, medium to coarse SAND, some Silt, coarse Gravel, Crushed Concrete, and Asphalt, trace cobble (fill); moist.		0.0	Collect sample 1B2 (0-5.5) for TCL SVOCs, TCL Pesticides, Herbicides, PCBs, TAL Metals, Mercury, Hex/Tri Chromium, Total Cyanide, and RCRA Characteristics.
2		Grey to brown, medium to coarse SAND, some Silt and coarse Gravel, trace cobble, concrete, and asphalt (fill); moist.			Collect sample 1B2 (1-2) for TCL VOCs and NJEPH.
3		Grey to brown, medium to coarse SAND, some Silt and coarse Gravel, trace cobble; moist.		0.0	
4				0.0	
5				0.0	
6		Lithology not noted.			
7					Bedrock encountered at 7 ft bls.

BORING/FEET 2611.0002Y000.GPJ ROUX.GDT 4/16/20



**ROUX ASSOCIATES, INC.**  
*Environmental Consulting  
 & Management*

209 Shafter Street  
 Islandia, NY 11749  
 Telephone: (631) 232-2600  
 Fax: (631) 232-9898

## SOIL BORING LOG

WELL NO. <b>1B3</b>	LATITUDE <b>236151.1245</b>	LONGITUDE <b>1014446.329</b>		
PROJECT NO./NAME <b>2611.0002Y000 / Spofford Ave</b>		LOCATION <b>1221 Spofford Avenue</b>		
APPROVED BY <b>L. Dolginko</b>	LOGGED BY <b>C. Wygel</b>	<b>Bronx, New York</b>		
DRILLING CONTRACTOR/DRILLER <b>Russo Demolition / Excavator</b>		GEOGRAPHIC AREA <b>Building 1B</b>		
DRILL BIT DIAMETER/TYPE <b>/ Excavator Bucket</b>	BOREHOLE DIAMETER	DRILLING EQUIPMENT/METHOD <b>Excavator / Test Pit</b>	SAMPLING METHOD <b>Test Pit</b>	START-FINISH DATE <b>11/19/18-11/19/18</b>
LAND SURFACE ELEVATION <b>36.53 (FT. ABOVE NAVD 83)</b>	DEPTH TO WATER <b>Not Measured</b>	BACKFILL <b>Soil Cuttings</b>		

Depth, feet	Graphic Log	Visual Description	Blow Counts per 6"	PID Values (ppm)	REMARKS
1		Brown, medium to coarse SAND, some Silt, coarse Gravel, Concrete, Asphalt, and Metal (fill); moist.		0.0	Collect sample 1B3 (0-4) for TCL SVOCs, TCL Pesticides, Herbicides, PCBs, TAL Metals, Mercury, Hex/Tri Chromium, Total Cyanide, and RCRA Characteristics.
2		Brown, fine to medium SAND, some Silt, trace cobble; moist.		0.0	Collect sample 1B3 (1-2) for TCL VOCs and NJEPH.
3			G	0.0	
4				0.1	
5					Bedrock encountered at 5 ft bls.

BORING/FEET 2611.0002Y000.GPJ ROUX.GDT 4/16/20



**ROUX ASSOCIATES, INC.**  
Environmental Consulting  
& Management

209 Shafter Street  
Islandia, NY 11749  
Telephone: (631) 232-2600  
Fax: (631) 232-9898

## SOIL BORING LOG

WELL NO. <b>1B4</b>	LATITUDE <b>236158.0684</b>	LONGITUDE <b>1014482.748</b>	
PROJECT NO./NAME <b>2611.0002Y000 / Spofford Ave</b>		LOCATION <b>1221 Spofford Avenue</b>	
APPROVED BY <b>L. Dolginko</b>	LOGGED BY <b>C. Wygel</b>	<b>Bronx, New York</b>	
DRILLING CONTRACTOR/DRILLER <b>Russo Demolition / Excavator</b>		GEOGRAPHIC AREA <b>Building 1B</b>	
DRILL BIT DIAMETER/TYPE <b>/ Excavator Bucket</b>	BOREHOLE DIAMETER	DRILLING EQUIPMENT/METHOD <b>Excavator / Test Pit</b>	SAMPLING METHOD <b>Test Pit</b>
LAND SURFACE ELEVATION <b>36.62(FT. ABOVE NAVD 83)</b>	DEPTH TO WATER <b>Not Measured</b>	BACKFILL <b>Soil Cuttings</b>	

Depth, feet	Graphic Log	Visual Description	Blow Counts per 6"	PID Values (ppm)	REMARKS
1		Grey to brown, medium to coarse SAND, some Silt, coarse Gravel, Brick, Concrete, and Asphalt (fill); moist.		0.0	Collect sample 1B4 (0-3) for TCL SVOCs, TCL Pesticides, Herbicides, PCBs, TAL Metals, Mercury, Hex/Tri Chromium, Total Cyanide, and RCRA Characteristics.
2		Brown, medium to coarse SAND, some Silt and coarse Gravel, trace cobble; moist.	G	0.0	Collect sample 1B4 (1-2) for TCL VOCs and NJEPH.
3				0.0	Bedrock encountered at 3 ft bls.

BORING/FEET 2611.0002Y000.GPJ ROUX.GDT 4/16/20



**ROUX ASSOCIATES, INC.**  
 Environmental Consulting  
 & Management

209 Shafter Street  
 Islandia, NY 11749  
 Telephone: (631) 232-2600  
 Fax: (631) 232-9898

## SOIL BORING LOG

WELL NO. <b>1B5</b>	LATITUDE <b>236167.1317</b>	LONGITUDE <b>1014509.938</b>
PROJECT NO./NAME <b>2611.0002Y000 / Spofford Ave</b>	LOCATION <b>1221 Spofford Avenue</b>	
APPROVED BY <b>L. Dolginko</b>	LOGGED BY <b>C. Wygel</b>	<b>Bronx, New York</b>
DRILLING CONTRACTOR/DRILLER <b>Russo Demolition / Excavator</b>		GEOGRAPHIC AREA <b>Building 1B</b>
DRILL BIT DIAMETER/TYPE <b>/ Excavator Bucket</b>	BOREHOLE DIAMETER	DRILLING EQUIPMENT/METHOD <b>Excavator / Test Pit</b>
LAND SURFACE ELEVATION <b>35.56 (FT. ABOVE NAVD 83)</b>	DEPTH TO WATER <b>Not Measured</b>	SAMPLING METHOD <b>Test Pit</b>
		START-FINISH DATE <b>11/19/18-11/19/18</b>
		BACKFILL <b>Soil Cuttings</b>

Depth, feet	Graphic Log	Visual Description	Blow Counts per 6"	PID Values (ppm)	REMARKS
1		Grey to brown, medium to coarse SAND, some Silt and coarse Gravel, trace brick, concrete, and metal (fill); moist.		0.2	Collect sample 1B5 (0-2.5) for TCL SVOCs, TCL Pesticides, Herbicides, PCBs, TAL Metals, Mercury, Hex/Tri Chromium, Total Cyanide, and RCRA Characteristics.
2		Brown, medium to coarse SAND, some Silt and coarse Gravel, little Cobble and Weathered Bedrock; moist.	G	0.2	Collect sample 1B5 (1-2) for TCL VOCs and NJEPH.
					Bedrock encountered at 2.5 ft bls.

BORING/FEET 2611.0002Y000.GPJ ROUX.GDT 4/16/20





ROUX ASSOCIATES, INC.  
Environmental Consulting  
& Management

209 Shafter Street  
Islandia, NY 11749  
Telephone: (631) 232-2600  
Fax: (631) 232-9898

### SOIL BORING LOG

WELL NO. <b>1B6</b>	LATITUDE <b>236066.357</b>	LONGITUDE <b>1014393.223</b>
PROJECT NO./NAME <b>2611.0002Y000 / Spofford Ave</b>		LOCATION <b>1221 Spofford Avenue</b>
APPROVED BY <b>L. Dolginko</b>	LOGGED BY <b>C. Wygel</b>	<b>Bronx, New York</b>
DRILLING CONTRACTOR/DRILLER <b>Russo Demolition / Excavator</b>		GEOGRAPHIC AREA <b>Building 1B</b>
DRILL BIT DIAMETER/TYPE <b>/ Excavator Bucket</b>	BOREHOLE DIAMETER	DRILLING EQUIPMENT/METHOD <b>Excavator / Test Pit</b>
LAND SURFACE ELEVATION <b>35.94 (FT. ABOVE NAVD 83)</b>	DEPTH TO WATER <b>Not Measured</b>	SAMPLING METHOD <b>Test Pit</b>
		START-FINISH DATE <b>11/19/18-11/19/18</b>
		BACKFILL <b>Soil Cuttings</b>

Depth, feet	Graphic Log	Visual Description	Blow Counts per 6"	PID Values (ppm)	REMARKS
1		Grey to brown, medium to coarse SAND, some Silt, coarse Gravel, and Crushed Concrete, little Brick, Asphalt, and Metal (fill); moist.		9.2	Collect sample 1B6 (0-1) for TCL VOCs, Paint Filter, and NJEPH.
2		Brown, medium to coarse SAND, some Silt and coarse Gravel, little Brick and Concrete (fill); moist.		2.6	Collect sample 1B6 (0-5.5) for TCL SVOCs, TCL Pesticides, Herbicides, PCBs, TAL Metals, Mercury, Hex/Tri Chromium, Total Cyanide, and RCRA Characteristics.
3				0.3	
4		Brown, medium to coarse SAND, some Silt and coarse Gravel, little Cobble; moist.		1.5	
5					
6					
7					
8					
9				0.5	
10					
11					Bedrock encountered at 11 ft bls.

BORING/FEET 2611.0002Y000.GPJ ROUX.GDT 4/16/20



ROUX ASSOCIATES, INC.  
Environmental Consulting  
& Management

209 Shafter Street  
Islandia, NY 11749  
Telephone: (631) 232-2600  
Fax: (631) 232-9898

# SOIL BORING LOG

WELL NO. <b>1B7</b>	LATITUDE <b>236071.5033</b>	LONGITUDE <b>1014429.247</b>
PROJECT NO./NAME <b>2611.0002Y000 / Spofford Ave</b>	LOCATION <b>1221 Spofford Avenue</b>	
APPROVED BY <b>L. Dolginko</b>	LOGGED BY <b>C. Wygel</b>	<b>Bronx, New York</b>
DRILLING CONTRACTOR/DRILLER <b>Russo Demolition / Excavator</b>		GEOGRAPHIC AREA <b>Building 1B</b>
DRILL BIT DIAMETER/TYPE <b>/ Excavator Bucket</b>	BOREHOLE DIAMETER	DRILLING EQUIPMENT/METHOD <b>Excavator / Test Pit</b>
LAND SURFACE ELEVATION <b>36.63 (FT. ABOVE NAVD 83)</b>	DEPTH TO WATER <b>Not Measured</b>	SAMPLING METHOD <b>Test Pit</b>
		START-FINISH DATE <b>11/19/18-11/19/18</b>
		BACKFILL <b>Soil Cuttings</b>

Depth, feet	Graphic Log	Visual Description	Blow Counts per 6"	PID Values (ppm)	REMARKS
1		Grey, edmium to coarse SAND, some Silt, coarse Gravel, Asphalt, and Crushed Concrete, little Brick and Metal (fill); moist.		0.3	Collect sample 1B7 (0-5.5) for TCL SVOCs, TCL Pesticides, Herbicides, PCBs, TAL Metals, Mercury, Hex/Tri Chromium, Total Cyanide, and RCRA Characteristics. <span style="float: right;">..1</span>
2		Brown, medium to coarse SAND, some Silt and coarse Gravel, little Brick and Crushed Concrete (fill); moist.		0.8	Collect sample 1B7 (1-2) for TCL VOCs and NJEPH. <span style="float: right;">..2</span>
3		Brown, medium to coarse SAND, some Silt and Gravel, little Cobble; moist.		0.7	<span style="float: right;">..3</span>
4					<span style="float: right;">..4</span>
5					<span style="float: right;">..5</span>
6					<span style="float: right;">..6</span>
7					<span style="float: right;">..7</span>
8					<span style="float: right;">..8</span>
9		Brown, medium to coarse SAND, some Weathered Bedrock; moist.		0.3	Bedrock encountered at 9 ft bls. <span style="float: right;">..9</span>

BORING/FEET 2611.0002Y000.GPJ ROUX.GDT 4/16/20



**ROUX ASSOCIATES, INC.**  
Environmental Consulting  
& Management

209 Shafter Street  
Islandia, NY 11749  
Telephone: (631) 232-2600  
Fax: (631) 232-9898

# SOIL BORING LOG

WELL NO. <b>1B8</b>	LATITUDE <b>236077.7523</b>	LONGITUDE <b>1014463.678</b>
PROJECT NO./NAME <b>2611.0002Y000 / Spofford Ave</b>		LOCATION <b>1221 Spofford Avenue</b>
APPROVED BY <b>L. Dolginko</b>	LOGGED BY <b>C. Wygel</b>	<b>Bronx, New York</b>
DRILLING CONTRACTOR/DRILLER <b>Russo Demolition / Excavator</b>		GEOGRAPHIC AREA <b>Building 1B</b>
DRILL BIT DIAMETER/TYPE <b>/ Excavator Bucket</b>	BOREHOLE DIAMETER	DRILLING EQUIPMENT/METHOD <b>Excavator / Test Pit</b>
LAND SURFACE ELEVATION <b>36.73 (FT. ABOVE NAVD 83)</b>	DEPTH TO WATER <b>Not Measured</b>	SAMPLING METHOD <b>Test Pit</b>
		START-FINISH DATE <b>11/19/18-11/19/18</b>
		BACKFILL <b>Soil Cuttings</b>

Depth, feet	Graphic Log	Visual Description	Blow Counts per 6"	PID Values (ppm)	REMARKS
1		Grey, CONCRETE, little medium to coarse Sand and coarse Gravel; moist.		0.0	Collect sample 1B8 (0-5.5) for TCL SVOCs, TCL Pesticides, Herbicides, PCBs, TAL Metals, Mercury, Hex/Tri Chromium, Total Cyanide, and RCRA Characteristics.
2		Brown, medium to coarse SAND, some Silt and coarse Gravel, little Brick, Asphalt, and Concrete (fill); moist.		0.0	Collect sample 1B8 (1-2) for TCL VOCs and NJEPH.
3		Brown, fine to medium SAND, some fine to medium Gravel and Cobble; moist.	G	0.0	
4		Brown, fine to medium SAND, some Weathered Bedrock; moist.		0.0	
5		Brown, fine to medium SAND, some Weathered Bedrock; moist.		0.0	
6					Bedrock encountered at 6 ft bls.

BORING/FEET 2611.0002Y000.GPJ ROUX.GDT 4/16/20



**ROUX ASSOCIATES, INC.**  
Environmental Consulting  
& Management

209 Shafter Street  
Islandia, NY 11749  
Telephone: (631) 232-2600  
Fax: (631) 232-9898

## SOIL BORING LOG

WELL NO. <b>1B9</b>	LATITUDE <b>236081.9183</b>	LONGITUDE <b>1014491.125</b>	
PROJECT NO./NAME <b>2611.0002Y000 / Spofford Ave</b>		LOCATION <b>1221 Spofford Avenue</b>	
APPROVED BY <b>L. Dolginko</b>	LOGGED BY <b>C. Wygel</b>	<b>Bronx, New York</b>	
DRILLING CONTRACTOR/DRILLER <b>Russo Demolition / Excavator</b>		GEOGRAPHIC AREA <b>Building 1B</b>	
DRILL BIT DIAMETER/TYPE <b>/ Excavator Bucket</b>	BOREHOLE DIAMETER	DRILLING EQUIPMENT/METHOD <b>Excavator / Test Pit</b>	SAMPLING METHOD <b>Test Pit</b>
LAND SURFACE ELEVATION <b>36.36 (FT. ABOVE NAVD 83)</b>	DEPTH TO WATER <b>Not Measured</b>	BACKFILL <b>Soil Cuttings</b>	

Depth, feet	Graphic Log	Visual Description	Blow Counts per 6"	PID Values (ppm)	REMARKS
1		Grey, medium to coarse SAND, some Silt, coarse Gravel, Cobble, and Crushed Concrete (fill); moist.		0.0	Collect sample 1B9 (0-5) for TCL SVOCs, TCL Pesticides, Herbicides, PCBs, TAL Metals, Mercury, Hex/Tri Chromium, Total Cyanide, and RCRA Characteristics.
2		Dark to light brown, medium to coarse SAND, some Silt, Gravel and Cobble, little Concrete, Brick, and Roots (fill); moist.		0.0	Collect sample 1B9 (1-2) for TCL VOCs and NJEPH.
3		Brown, medium to coarse SAND, some Silt and coarse Gravel, little Cobble; moist.	G	0.0	
4					
5		Brown, medium to coarse SAND, some Weathered Bedrock; moist.		0.0	Bedrock encountered at 5 ft bls.

BORING/FEET 2611.0002Y000.GPJ ROUX.GDT 4/16/20



**ROUX ASSOCIATES, INC.**  
*Environmental Consulting  
 & Management*

209 Shafter Street  
 Islandia, NY 11749  
 Telephone: (631) 232-2600  
 Fax: (631) 232-9898

## SOIL BORING LOG

WELL NO. <b>RXMW-9</b>	LATITUDE <b>Not Measured</b>	LONGITUDE <b>Not Measured</b>
PROJECT NO./NAME <b>2611.0002Y000 / Spofford Ave</b>		LOCATION <b>1221 Spofford Avenue</b>
APPROVED BY <b>L. Dolginko</b>	LOGGED BY <b>M. Todaro</b>	<b>Bronx, New York</b>
DRILLING CONTRACTOR/DRILLER <b>Russo Demolition /</b>		GEOGRAPHIC AREA
DRILL BIT DIAMETER/TYPE <b>/ Excavator Bucket</b>	BOREHOLE DIAMETER	DRILLING EQUIPMENT/METHOD <b>Excavator / Test Pit</b>
LAND SURFACE ELEVATION <b>Not Measured</b>	DEPTH TO WATER <b>Not Measured</b>	BACKFILL <b>Soil Cuttings</b>
		SAMPLING METHOD
		START-FINISH DATE <b>11/21/18-11/21/18</b>

Depth, feet	Graphic Log	Visual Description	Blow Counts per 6"	PID Values (ppm)	REMARKS
1		Brown, fine to medium SAND, some Silt and Gravel, little Brick and Concrete (fill); moist.			
2					
3					
4					
5					
6		Grey, WEATHERED BEDROCK; moist.			Bedrock encountered at 6 ft bls.

BORING/FEET 2611.0002Y000.GPJ ROUX.GDT 4/16/20



**ROUX ASSOCIATES, INC.**  
Environmental Consulting  
& Management

209 Shafter Street  
Islandia, NY 11749  
Telephone: (631) 232-2600  
Fax: (631) 232-9898

# SOIL BORING LOG

WELL NO. <b>2A1</b>	NORTHING <b>Not Measured</b>	EASTING <b>Not Measured</b>
PROJECT NO./NAME <b>2611.0002Y000 / Spofford</b>		LOCATION <b>1221 Spofford Ave Bronx, NY</b>
APPROVED BY <b>L. Doljinko</b>	LOGGED BY <b>M. Todaro</b>	
DRILLING CONTRACTOR/DRILLER <b>Russo Demolition / Excavator</b>		GEOGRAPHIC AREA <b>Building 2A</b>
DRILL BIT DIAMETER/TYPE <b>Excavator Bucket /</b>	BOREHOLE DIAMETER <b>Test Pit</b>	DRILLING EQUIPMENT/METHOD <b>Excavator / Test Pit</b>
LAND SURFACE ELEVATION <b>Not Measured</b>	DEPTH TO WATER <b>Not Measured</b>	BACKFILL <b>Soil Cuttings</b>
		SAMPLING METHOD <b>Test Pit</b>
		START-FINISH DATE <b>5/2/19-5/2/19</b>

Depth, feet	Graphic Log	Visual Description	Blow Counts per 6"	PID Values (ppm)	REMARKS
1		Dark brown, fine to medium SAND, some Gravel, Cobble, Brick, and Asphalt (fill); moist.		0.0	Collect sample 2A1(0-1) for VOCs, NJEPH.
2		Dark brown, fine to medium SAND, some Bedrock, Gravel, Cobble, Brick, and Asphalt (fill); moist.	G	0.0	Collect sample 2A1(0-2) for SVOCs, Pesticides, Herbicides, PCBs, Metals, RCRA Characteristics, Cyanide, Mercury, Hex/Tri Chromium.
3					
4					Bedrock encountered at 4 ft bls.

BORING/FEET 2611.0002Y000\_PHASE2.GPJ ROUX.GDT 5/29/19



ROUX ASSOCIATES, INC.  
Environmental Consulting  
& Management

209 Shafter Street  
Islandia, NY 11749  
Telephone: (631) 232-2600  
Fax: (631) 232-9898

# SOIL BORING LOG

WELL NO. <b>2A2</b>	NORTHING <b>Not Measured</b>	EASTING <b>Not Measured</b>
PROJECT NO./NAME <b>2611.0002Y000 / Spofford</b>		LOCATION <b>1221 Spofford Ave</b>
APPROVED BY <b>L. Doljinko</b>	LOGGED BY <b>M. Todaro</b>	<b>Bronx, NY</b>
DRILLING CONTRACTOR/DRILLER <b>Russo Demolition / Excavator</b>		GEOGRAPHIC AREA <b>Building 2A</b>
DRILL BIT DIAMETER/TYPE <b>Excavator Bucket /</b>	BOREHOLE DIAMETER <b>Test Pit</b>	DRILLING EQUIPMENT/METHOD <b>Excavator / Test Pit</b>
LAND SURFACE ELEVATION <b>Not Measured</b>	DEPTH TO WATER <b>Not Measured</b>	BACKFILL <b>Soil Cuttings</b>
SAMPLING METHOD <b>Test Pit</b>		
START-FINISH DATE <b>5/2/19-5/2/19</b>		

Depth, feet	Graphic Log	Visual Description	Blow Counts per 6"	PID Values (ppm)	REMARKS
1		Dark brown, fine to medium SAND, some Gravel, Cobble, Brick, and Asphalt (fill); moist.		0.1	Collect sample 2A2(0-1) for VOCs, NJEPH.
2					Collect sample 2A2(0-2) for SVOCs, Pesticides, Herbicides, PCBs, Metals, RCRA Characteristics, Cyanide, Mercury, Hex/Tri Chromium.
3		Dark brown, fine to medium SAND, some Bedrock, Gravel, Cobble, Brick, and Asphalt (fill); moist.			
4					
5				0.1	
6					
7					
8					
9					
10					Bedrock encountered at 10 ft bls.

BORING/FEET 2611.0002Y000\_PHASE2.GPJ ROUX.GDT 5/29/19







ROUX ASSOCIATES, INC.  
Environmental Consulting  
& Management

209 Shafter Street  
Islandia, NY 11749  
Telephone: (631) 232-2600  
Fax: (631) 232-9898

### SOIL BORING LOG

WELL NO. <b>2A4</b>	NORTHING <b>Not Measured</b>	EASTING <b>Not Measured</b>
PROJECT NO./NAME <b>2611.0002Y000 / Spofford</b>		LOCATION <b>1221 Spofford Ave</b>
APPROVED BY <b>L. Dolginko</b>	LOGGED BY <b>M. Todaro</b>	<b>Bronx, NY</b>
DRILLING CONTRACTOR/DRILLER <b>Russo Demolition / Excavator</b>		GEOGRAPHIC AREA <b>Building 2A</b>
DRILL BIT DIAMETER/TYPE <b>Excavator Bucket /</b>	BOREHOLE DIAMETER <b>Test Pit</b>	DRILLING EQUIPMENT/METHOD <b>Excavator / Test Pit</b>
LAND SURFACE ELEVATION <b>Not Measured</b>	DEPTH TO WATER <b>Not Measured</b>	SAMPLING METHOD <b>Test Pit</b>
		START-FINISH DATE <b>5/2/19-5/2/19</b>
		BACKFILL <b>Soil Cuttings</b>

Depth, feet	Graphic Log	Visual Description	Blow Counts per 6"	PID Values (ppm)	REMARKS
1	△ △ △ △ △ △ △ △ △	Brown, medium to coarse SAND, some Gravel, little Silt, Brick, Asphalt, and Debris (fill); moist.		0.0	Collect sample 2A4(0-1) for VOCs, NJEPH. ...1
2	△ △ △ △ △ △ △ △ △			0.2	Collect 2A4(0-2) for SVOCs, Pesticides, Herbicides, PCBs, Metals, RCRA Characteristics, Cyanide, Mercury, Hex/Tri Chromium. ...2
3	△ △ △ △ △ △ △ △ △	Brown, medium to coarse SAND, some Gravel and Bedrock, little Silt, Brick, Asphalt, and Debris (fill); moist.			...3
4	△ △ △ △ △ △ △ △ △				...4
5	△ △ △ △ △ △ △ △ △				...5
6	△ △ △ △ △ △ △ △ △			1.1	...6
7	△ △ △ △ △ △ △ △ △				...7
8	△ △ △ △ △ △ △ △ △				...8
9	△ △ △ △ △ △ △ △ △			0.8	...9
10	△ △ △ △ △ △ △ △ △				...10
11	△ △ △ △ △ △ △ △ △				...11
12	△ △ △ △ △ △ △ △ △				...12
13	△ △ △ △ △ △ △ △ △				...13
14	△ △ △ △ △ △ △ △ △				...14
					Bedrock encountered at 14.5 ft bls.

BORING/FEET 2611.0002Y000\_PHASE2.GPJ ROUX.GDT 5/29/19



ROUX ASSOCIATES, INC.  
Environmental Consulting  
& Management

209 Shafter Street  
Islandia, NY 11749  
Telephone: (631) 232-2600  
Fax: (631) 232-9898

# SOIL BORING LOG

WELL NO. <b>2A5</b>	NORTHING <b>Not Measured</b>	EASTING <b>Not Measured</b>
PROJECT NO./NAME <b>2611.0002Y000 / Spofford</b>		LOCATION <b>1221 Spofford Ave</b>
APPROVED BY <b>L. Dolginko</b>	LOGGED BY <b>M. Todaro</b>	<b>Bronx, NY</b>
DRILLING CONTRACTOR/DRILLER <b>Russo Demolition / Excavator</b>		GEOGRAPHIC AREA <b>Building 2A</b>
DRILL BIT DIAMETER/TYPE <b>Excavator Bucket /</b>	BOREHOLE DIAMETER <b>Test Pit</b>	DRILLING EQUIPMENT/METHOD <b>Excavator / Test Pit</b>
LAND SURFACE ELEVATION <b>Not Measured</b>	DEPTH TO WATER <b>Not Measured</b>	BACKFILL <b>Soil Cuttings</b>
SAMPLING METHOD <b>Test Pit</b>		
START-FINISH DATE <b>5/2/19-5/2/19</b>		

Depth, feet	Graphic Log	Visual Description	Blow Counts per 6"	PID Values (ppm)	REMARKS
1	△ △ △ △ △ △ △ △ △	Brown, fine to medium SAND, some Clay, Gravel, Asphalt, Brick, and Debris (fill); moist.		0.0	Collect sample 2A5(0-1) for VOCs, NJEPH. <span style="float:right">1</span>
2	△ △ △ △ △ △ △ △ △			0.1	Collect 2A5(0-2) for SVOCs, Pesticides, Herbicides, PCBs, Metals, RCRA Characteristics, Cyanide, Mercury, Hex/Tri Chromium. <span style="float:right">2</span>
3	△ △ △ △ △ △ △ △ △	Brown, fine to medium SAND, some Cobble, little Gravel and Clay, trace Brick and Asphalt (fill); moist.			<span style="float:right">3</span>
4	△ △ △ △ △ △ △ △ △			0.2	<span style="float:right">4</span>
5	△ △ △ △ △ △ △ △ △				<span style="float:right">5</span>
6	△ △ △ △ △ △ △ △ △			4.3	<span style="float:right">6</span>
7	△ △ △ △ △ △ △ △ △				<span style="float:right">7</span>
8	△ △ △ △ △ △ △ △ △	Brown, fine to medium SAND, some Cobble and Bedrock, little Gravel and Clay, trace Brick and Asphalt (fill); moist.			<span style="float:right">8</span>
9	△ △ △ △ △ △ △ △ △				<span style="float:right">9</span>
10	△ △ △ △ △ △ △ △ △				<span style="float:right">10</span>
11	△ △ △ △ △ △ △ △ △				<span style="float:right">11</span>
12	△ △ △ △ △ △ △ △ △				<span style="float:right">12</span>
13	△ △ △ △ △ △ △ △ △				<span style="float:right">13</span>
14	△ △ △ △ △ △ △ △ △				Bedrock encountered at 14 ft bls. <span style="float:right">14</span>

BORING/FEET 2611.0002Y000\_PHASE2.GPJ ROUX.GDT 5/29/19



ROUX ASSOCIATES, INC.  
Environmental Consulting  
& Management

209 Shafter Street  
Islandia, NY 11749  
Telephone: (631) 232-2600  
Fax: (631) 232-9898

# SOIL BORING LOG

WELL NO. <b>2B1</b>	NORTHING <b>Not Measured</b>	EASTING <b>Not Measured</b>
PROJECT NO./NAME <b>2611.0002Y000 / Spofford</b>		LOCATION <b>1221 Spofford Ave</b>
APPROVED BY <b>L. Doljinko</b>	LOGGED BY <b>M. Todaro</b>	<b>Bronx, NY</b>
DRILLING CONTRACTOR/DRILLER <b>Russo Demolition / Excavator</b>		GEOGRAPHIC AREA <b>Building 2B</b>
DRILL BIT DIAMETER/TYPE <b>Excavator Bucket /</b>	BOREHOLE DIAMETER <b>Test Pit</b>	DRILLING EQUIPMENT/METHOD <b>Excavator / Test Pit</b>
LAND SURFACE ELEVATION <b>Not Measured</b>	DEPTH TO WATER <b>Not Measured</b>	BACKFILL <b>Soil Cuttings</b>
		SAMPLING METHOD <b>Test Pit</b>
		START-FINISH DATE <b>5/2/19-5/2/19</b>

Depth, feet	Graphic Log	Visual Description	Blow Counts per 6"	PID Values (ppm)	REMARKS
	△ △ △	Dark brown, fine to medium SAND, some Gravel, Cobble, Brick, and Asphalt (fill); moist.		0.0	Collect sample 2B1(0-1) for VOCs, NJEPH.
5	△ △ △	Dark brown, fine to medium SAND, some Gravel, Cobble, Brick, and Asphalt (fill); wet.		0.0	Collect sample 2B1(5-6) for VOCs, NJEPH.
10	△ △ △		G	0.0	Collect sample 2B1(5-10) for SVOCs, Pesticides, Herbicides, PCBs, Metals, RCRA Characteristics, Cyanide, Mercury, Hex/Tri Chromium.
	△ △ △			0.0	Collect sample 2B1(10-11) for VOCs, NJEPH.
	△ △ △				Collect sample 2B1(10-15) for SVOCs, Pesticides, Herbicides, PCBs, Metals, RCRA Characteristics, Cyanide, Mercury, Hex/Tri Chromium.
15	△ △ △				Bedrock encountered at 15 ft bls.

BORING/FEET 2611.0002Y000\_PHASE2.GPJ ROUX.GDT 5/29/19



ROUX ASSOCIATES, INC.  
Environmental Consulting  
& Management

209 Shafter Street  
Islandia, NY 11749  
Telephone: (631) 232-2600  
Fax: (631) 232-9898

# SOIL BORING LOG

WELL NO. <b>2B10</b>	NORTHING <b>Not Measured</b>	EASTING <b>Not Measured</b>
PROJECT NO./NAME <b>2611.0002Y000 / Spofford</b>		LOCATION <b>1221 Spofford Ave</b>
APPROVED BY <b>L. Dolginko</b>	LOGGED BY <b>M. Todaro</b>	<b>Bronx, NY</b>
DRILLING CONTRACTOR/DRILLER <b>Russo Demolition / Excavator</b>		GEOGRAPHIC AREA <b>Building 2B</b>
DRILL BIT DIAMETER/TYPE <b>Excavator Bucket /</b>	BOREHOLE DIAMETER <b>Test Pit</b>	DRILLING EQUIPMENT/METHOD <b>Excavator / Test Pit</b>
LAND SURFACE ELEVATION <b>Not Measured</b>	DEPTH TO WATER <b>Not Measured</b>	BACKFILL <b>Soil Cuttings</b>
SAMPLING METHOD <b>Test Pit</b>		
START-FINISH DATE <b>5/3/19-5/3/19</b>		

Depth, feet	Graphic Log	Visual Description	Blow Counts per 6"	PID Values (ppm)	REMARKS
1	△ △ △ △ △ △ △ △ △	Brown, medium to coarse SAND, some Cobble, Gravel, Brick, Asphalt, and Debris, little Silt (fill); moist.		0.0	Collect sample 2B10(0-1) for VOCs, NJEPH. <span style="float:right">1</span>
2	△ △ △ △ △ △ △ △ △			0.0	<span style="float:right">2</span>
3	△ △ △ △ △ △ △ △ △			0.0	Collect sample 2B10(0-5) for SVOCs, Pesticides, Herbicides, PCBs, Metals, RCRA Characteristics, Cyanide, Mercury, Hex/Tri Chromium. <span style="float:right">3</span>
4	△ △ △ △ △ △ △ △ △				<span style="float:right">4</span>
5	△ △ △ △ △ △ △ △ △				<span style="float:right">5</span>
6	△ △ △ △ △ △ △ △ △			G	0.0 Collect sample 2B10(5-6) for VOCs, NJEPH. <span style="float:right">6</span>
7	△ △ △ △ △ △ △ △ △				<span style="float:right">7</span>
8	△ △ △ △ △ △ △ △ △			0.0	Collect sample 2B10(5-10) for SVOCs, Pesticides, Herbicides, PCBs, Metals, RCRA Characteristics, Cyanide, Mercury, Hex/Tri Chromium. <span style="float:right">8</span>
9	△ △ △ △ △ △ △ △ △				<span style="float:right">9</span>
10	△ △ △ △ △ △ △ △ △			0.0	Collect sample 2B10(10-11) for VOCs, NJEPH. <span style="float:right">10</span>
11	△ △ △ △ △ △ △ △ △	Brown, medium to coarse SAND, some Bedrock, Cobble, Gravel, Brick, Asphalt, and Debris, little Silt (fill); moist.		0.0	Collect sample 2B10(10-12) for SVOCs, Pesticides, Herbicides, PCBs, Metals, RCRA Characteristics, Cyanide, Mercury, Hex/Tri Chromium. <span style="float:right">11</span>
12	△ △ △ △ △ △ △ △ △				Bedrock encountered at 12 ft bls. <span style="float:right">12</span>

BORING/FEET 2611.0002Y000\_PHASE2.GPJ ROUX.GDT 5/29/19



**ROUX ASSOCIATES, INC.**  
Environmental Consulting  
& Management

209 Shafter Street  
Islandia, NY 11749  
Telephone: (631) 232-2600  
Fax: (631) 232-9898

**SOIL BORING LOG**

WELL NO. <b>2B11</b>	NORTHING <b>Not Measured</b>	EASTING <b>Not Measured</b>
PROJECT NO./NAME <b>2611.0002Y000 / Spofford</b>		LOCATION <b>1221 Spofford Ave</b>
APPROVED BY <b>L. Doljinko</b>	LOGGED BY <b>M. Todaro</b>	<b>Bronx, NY</b>
DRILLING CONTRACTOR/DRILLER <b>Russo Demolition / Excavator</b>		GEOGRAPHIC AREA <b>Building 2B</b>
DRILL BIT DIAMETER/TYPE <b>Excavator Bucket /</b>	BOREHOLE DIAMETER <b>Test Pit</b>	DRILLING EQUIPMENT/METHOD <b>Excavator / Test Pit</b>
LAND SURFACE ELEVATION <b>Not Measured</b>	DEPTH TO WATER <b>Not Measured</b>	SAMPLING METHOD <b>Test Pit</b>
		START-FINISH DATE <b>5/3/19-5/3/19</b>
		BACKFILL <b>Soil Cuttings</b>

Depth, feet	Graphic Log	Visual Description	Blow Counts per 6"	PID Values (ppm)	REMARKS
		Brown, medium to coarse SAND, some Cobble, Gravel, Brick, Asphalt, and Debris (fill); moist.		0.0	Collect sample 2B11(0-1) for VOCs, NJEPH.
				0.0	
				0.0	Collect sample 2B11(0-5) for SVOCs, Pesticides, Herbicides, PCBs, Metals, RCRA Characteristics, Cyanide, Mercury, Hex/Tri Chromium.
				0.0	
<b>5</b>				0.0	Collect sample 2B11(5-6) for VOCs, NJEPH.
				0.0	
				0.0	Collect sample 2B11(5-10) for SVOCs, Pesticides, Herbicides, PCBs, Metals, RCRA Characteristics, Cyanide, Mercury, Hex/Tri Chromium.
				0.0	
<b>10</b>		Brown, medium to coarse SAND, some Bedrock, Cobble, Gravel, Brick, Asphalt, and Debris (fill); moist.			Collect sample 2B11(10-11) for VOCs, NJEPH.
					Collect sample 2B11(10-15) for SVOCs, Pesticides, Herbicides, PCBs, Metals, RCRA Characteristics, Cyanide, Mercury, Hex/Tri Chromium.
<b>15</b>					Bedrock encountered at 15 ft bls.

BORING/FEET 2611.0002Y000\_PHASE2.GPJ ROUX.GDT 5/29/19



ROUX ASSOCIATES, INC.  
Environmental Consulting  
& Management

209 Shafter Street  
Islandia, NY 11749  
Telephone: (631) 232-2600  
Fax: (631) 232-9898

# SOIL BORING LOG

WELL NO. <b>2B2</b>	NORTHING <b>Not Measured</b>	EASTING <b>Not Measured</b>
PROJECT NO./NAME <b>2611.0002Y000 / Spofford</b>	LOCATION <b>1221 Spofford Ave</b>	
APPROVED BY <b>L. Dolginko</b>	LOGGED BY <b>M. Todaro</b>	<b>Bronx, NY</b>
DRILLING CONTRACTOR/DRILLER <b>Russo Demolition / Excavator</b>		GEOGRAPHIC AREA <b>Building 2B</b>
DRILL BIT DIAMETER/TYPE <b>Excavator Bucket /</b>	BOREHOLE DIAMETER <b>Test Pit</b>	DRILLING EQUIPMENT/METHOD <b>Excavator / Test Pit</b>
LAND SURFACE ELEVATION <b>Not Measured</b>	DEPTH TO WATER <b>Not Measured</b>	BACKFILL <b>Soil Cuttings</b>
		SAMPLING METHOD <b>Test Pit</b>
START-FINISH DATE <b>5/6/19-5/6/19</b>		

Depth, feet	Graphic Log	Visual Description	Blow Counts per 6"	PID Values (ppm)	REMARKS	
	△ △ △	Brown, medium to coarse SAND, some Gravel, Cobble, Asphalt, Brick, and Debris (fill); moist.		0.0	Collect sample 2B2(0-1) for VOCs, NJEPH.	
	△ △ △			0.0		
	△ △ △					
	△ △ △					
	△ △ △					
	△ △ △					
	△ △ △					
	△ △ △					
5	△ △ △					5
	△ △ △					
	△ △ △					
	△ △ △					
	△ △ △					
	△ △ △					
	△ △ △					
	△ △ △					
	△ △ △					
	△ △ △					
10	△ △ △					10
	△ △ △					
	△ △ △					
	△ △ △					
	△ △ △					
	△ △ △					
	△ △ △					
	△ △ △					
	△ △ △					
15	△ △ △				15	
	△ △ △					
	△ △ △					
	△ △ △					
	△ △ △					
	△ △ △					
	△ △ △					
	△ △ △					
	△ △ △					
	△ △ △					
	△ △ △	Brown, medium to coarse SAND, some Bedrock, Gravel, Cobble, Asphalt, Brick, and Debris (fill); moist.		0.0	Collect sample 2B2(15-16) for VOCs, NJEPH. Collect sample 2B2(15-17) for SVOCs, Pesticides, Herbicides, PCBs, Metals, RCRA Characteristics, Cyanide, Mercury, Hex/Tri Chromium.	
	△ △ △				Bedrock encountered at 17 ft bls.	

BORING/FEET 2611.0002Y000\_PHASE2.GPJ ROUX.GDT 5/29/19



ROUX ASSOCIATES, INC.  
Environmental Consulting  
& Management

209 Shafter Street  
Islandia, NY 11749  
Telephone: (631) 232-2600  
Fax: (631) 232-9898

### SOIL BORING LOG

WELL NO. <b>2B3</b>	NORTHING <b>Not Measured</b>	EASTING <b>Not Measured</b>
PROJECT NO./NAME <b>2611.0002Y000 / Spofford</b>		LOCATION <b>1221 Spofford Ave</b>
APPROVED BY <b>L. Dolginko</b>	LOGGED BY <b>M. Todaro</b>	<b>Bronx, NY</b>
DRILLING CONTRACTOR/DRILLER <b>Russo Demolition / Excavator</b>		GEOGRAPHIC AREA <b>Building 2B</b>
DRILL BIT DIAMETER/TYPE <b>Excavator Bucket /</b>	BOREHOLE DIAMETER <b>Test Pit</b>	DRILLING EQUIPMENT/METHOD <b>Excavator / Test Pit</b>
LAND SURFACE ELEVATION <b>Not Measured</b>	DEPTH TO WATER <b>Not Measured</b>	SAMPLING METHOD <b>Test Pit</b>
		START-FINISH DATE <b>5/6/19-5/6/19</b>
		BACKFILL <b>Soil Cuttings</b>

Depth, feet	Graphic Log	Visual Description	Blow Counts per 6"	PID Values (ppm)	REMARKS
1	△ △ △ △ △ △ △ △ △	Brown, medium to coarse SAND, some fine Sand, Gravel, Cobble, Asphalt, Brick, and Debris (fill); moist.		0.0	Collect sample 2B3(0-1) for VOCs, NJEPH. 1
2	△ △ △ △ △ △ △ △ △		0.0	2	
3	△ △ △ △ △ △ △ △ △		Collect sample 2B3(0-5) for SVOCs, Pesticides, Herbicides, PCBs, Metals, RCRA Characteristics, Cyanide, Mercury, Hex/Tri Chromium, Paint Filter. 3	0.0	4
4	△ △ △ △ △ △ △ △ △			5	
5	△ △ △ △ △ △ △ △ △				
6	△ △ △ △ △ △ △ △ △	Brown, medium to coarse SAND, some fine Sand, Gravel, Cobble, Asphalt, Brick, and Debris (fill); wet.		0.0	Collect sample 2B3(5-6) for VOCs, NJEPH. 6
7	△ △ △ △ △ △ △ △ △		G	7	
8	△ △ △ △ △ △ △ △ △		Collect sample 2B3(5-10) for SVOCs, Pesticides, Herbicides, PCBs, Metals, RCRA Characteristics, Cyanide, Mercury, Hex/Tri Chromium. 8		
9	△ △ △ △ △ △ △ △ △				9
10	△ △ △ △ △ △ △ △ △			10	
11	△ △ △ △ △ △ △ △ △	Brown, medium to coarse SAND, some Bedrock, fine Sand, Gravel, Cobble, Asphalt, Brick, and Debris (fill); moist.			Collect sample 2B3(10-11) for VOCs, NJEPH. 11
12	△ △ △ △ △ △ △ △ △			12	
13	△ △ △ △ △ △ △ △ △				

BORING/FEET 2611.0002Y000\_PHASE2.GPJ ROUX.GDT 5/29/19



ROUX ASSOCIATES, INC.  
Environmental Consulting  
& Management

209 Shafter Street  
Islandia, NY 11749  
Telephone: (631) 232-2600  
Fax: (631) 232-9898

# SOIL BORING LOG

WELL NO. <b>2B4</b>	NORTHING <b>Not Measured</b>	EASTING <b>Not Measured</b>
PROJECT NO./NAME <b>2611.0002Y000 / Spofford</b>		LOCATION <b>1221 Spofford Ave</b>
APPROVED BY <b>L. Dolginko</b>	LOGGED BY <b>M. Todaro</b>	<b>Bronx, NY</b>
DRILLING CONTRACTOR/DRILLER <b>Russo Demolition / Excavator</b>		GEOGRAPHIC AREA <b>Building 2B</b>
DRILL BIT DIAMETER/TYPE <b>Excavator Bucket /</b>	BOREHOLE DIAMETER <b>Test Pit</b>	DRILLING EQUIPMENT/METHOD <b>Excavator / Test Pit</b>
LAND SURFACE ELEVATION <b>Not Measured</b>	DEPTH TO WATER <b>Not Measured</b>	BACKFILL <b>Soil Cuttings</b>
		SAMPLING METHOD <b>Test Pit</b>
		START-FINISH DATE <b>5/6/19-5/6/19</b>

Depth, feet	Graphic Log	Visual Description	Blow Counts per 6"	PID Values (ppm)	REMARKS	
	△ △ △	Brown, medium to coarse SAND, some Gravel, Cobble, Asphalt, Brick, and Debris (fill); moist.		0.0	Collect sample 2B4(0-1) for VOCs, NJEPH.	
	△ △ △			0.0		
	△ △ △					
	△ △ △					
	△ △ △					
	△ △ △					
	△ △ △					
	△ △ △					
5	△ △ △					5
	△ △ △					
	△ △ △					
	△ △ △					
	△ △ △					
	△ △ △					
	△ △ △					
10	△ △ △				10	
	△ △ △					
	△ △ △					
	△ △ △					
	△ △ △					
	△ △ △					
	△ △ △					
	△ △ △					
15	△ △ △				15	
	△ △ △	Brown, medium to coarse SAND, some Bedrock, Gravel, Cobble, Asphalt, Brick, and Debris (fill); moist.			Collect sample 2B4(15-16) for VOCs, NJEPH.	
	△ △ △				Collect sample 2B4(15-18) for SVOCs, Pesticides, Herbicides, PCBs, Metals, RCRA Characteristics, Cyanide, Mercury, Hex/Tri Chromium.	
	△ △ △					
	△ △ △					
	△ △ △				Bedrock encountered at 18 ft bls.	

BORING/FEET 2611.0002Y000\_PHASE2.GPJ ROUX.GDT 5/29/19





**ROUX ASSOCIATES, INC.**  
Environmental Consulting  
& Management

209 Shafter Street  
Islandia, NY 11749  
Telephone: (631) 232-2600  
Fax: (631) 232-9898

### SOIL BORING LOG

WELL NO. <b>2B5</b>	NORTHING <b>Not Measured</b>	EASTING <b>Not Measured</b>
PROJECT NO./NAME <b>2611.0002Y000 / Spofford</b>		LOCATION <b>1221 Spofford Ave Bronx, NY</b>
APPROVED BY <b>L. Dolginko</b>	LOGGED BY <b>M. Todaro</b>	
DRILLING CONTRACTOR/DRILLER <b>Russo Demolition / Excavator</b>		GEOGRAPHIC AREA <b>Building 2B</b>
DRILL BIT DIAMETER/TYPE <b>Excavator Bucket /</b>	BOREHOLE DIAMETER <b>Test Pit</b>	DRILLING EQUIPMENT/METHOD <b>Excavator / Test Pit</b>
LAND SURFACE ELEVATION <b>Not Measured</b>	DEPTH TO WATER <b>Not Measured</b>	BACKFILL <b>Soil Cuttings</b>
		SAMPLING METHOD <b>Test Pit</b>
		START-FINISH DATE <b>5/7/19-5/7/19</b>

Depth, feet	Graphic Log	Visual Description	Blow Counts per 6"	PID Values (ppm)	REMARKS
1		Brown, medium to coarse SAND, some Gravel, Cobble, Concrete, Brick, Asphalt, and Debris (fill); moist.		0.0	Collect sample 2B5(0-1) for VOCs, NJEPH.
2					
3					
4					
5					
6					
7					
8					
9					
10					
		Brown, medium to coarse SAND, some Bedrock, Gravel, Cobble, Concrete, Brick, Asphalt, and Debris (fill); moist.		0.0	Collect sample 2B5(5-6) for VOCs, NJEPH.
				0.0	Collect sample 2B5(5-10) for SVOCs, Pesticides, Herbicides, PCBs, Metals, RCRA Characteristics, Cyanide, Mercury, Hex/Tri Chromium.
					Bedrock encountered at 10 ft bls.

BORING/FEET 2611.0002Y000\_PHASE2.GPJ ROUX.GDT 5/29/19



ROUX ASSOCIATES, INC.  
Environmental Consulting  
& Management

209 Shafter Street  
Islandia, NY 11749  
Telephone: (631) 232-2600  
Fax: (631) 232-9898

# SOIL BORING LOG

WELL NO. <b>2B6</b>	NORTHING <b>Not Measured</b>	EASTING <b>Not Measured</b>
PROJECT NO./NAME <b>2611.0002Y000 / Spofford</b>		LOCATION <b>1221 Spofford Ave</b>
APPROVED BY <b>L. Dolginko</b>	LOGGED BY <b>M. Todaro/P. Kilkelly</b>	<b>Bronx, NY</b>
DRILLING CONTRACTOR/DRILLER <b>Russo Demolition/AARCO / Excavator</b>		GEOGRAPHIC AREA <b>Building 2B</b>
DRILL BIT DIAMETER/TYPE <b>Excavator Bucket /</b>	BOREHOLE DIAMETER <b>Test Pit</b>	DRILLING EQUIPMENT/METHOD <b>Excavator / Test Pit</b>
LAND SURFACE ELEVATION <b>Not Measured</b>	DEPTH TO WATER <b>Not Measured</b>	BACKFILL <b>Soil Cuttings</b>
		SAMPLING METHOD <b>Test Pit</b>
		START-FINISH DATE <b>5/3/19-5/10/19</b>

Depth, feet	Graphic Log	Visual Description	Blow Counts per 6"	PID Values (ppm)	REMARKS
.....	△ △ △	Brown, medium to coarse SAND, some fine Sand, Cobble, Gravel, Brick, Asphalt, and Debris, little Silt (fill); moist.		0.0	Collect sample 2B6(0-1) for VOCs, NJEPH.
.....	△ △ △			0.0	
.....	△ △ △				Collect sample 2B6(0-5) for SVOCs, Pesticides, Herbicides, PCBs, Metals, RCRA Characteristics, Cyanide, Mercury, Hex/Tri Chromium.
.....	△ △ △			0.9	
<b>5</b>	△ △ △			12.3	
.....	△ △ △				Collect sample 2B6(5-10) for SVOCs, Pesticides, Herbicides, PCBs, Metals, RCRA Characteristics, Cyanide, Mercury, Hex/Tri Chromium.
.....	△ △ △			130.5	
.....	△ △ △			22.9	
<b>10</b>	△ △ △			0.0	<b>10</b>
.....	△ △ △				Collect sample 2B6(8-9) for VOCs, NJEPH.
.....	△ △ △		0.0	Collect sample 2B6(10-11) for VOCs, NJEPH.	
.....	△ △ △			Collect sample 2B6(10-15) for SVOCs, Pesticides, Herbicides, PCBs, Metals, RCRA Characteristics, Cyanide, Mercury, Hex/Tri Chromium.	
<b>15</b>	△ △ △		0.0		<b>15</b>
.....	△ △ △				Collect sample 2B6(15-16) for VOCs, NJEPH.
.....	△ △ △			Collect sample 2B6(15-20) for SVOCs, Pesticides, Herbicides, PCBs, Metals, RCRA Characteristics, Cyanide, Mercury, Hex/Tri Chromium.	
.....	△ △ △				
<b>20</b>	△ △ △				<b>20</b>
.....	△ △ △	Grey to reddish brown, fine SAND and SILT, some Clay and Bedrock; moist.			Collect sample 2B6(22-23) for VOCs, NJEPH.
.....	△ △ △	Green, WEATHERED BEDROCK, some medium to fine Sand; moist.			
.....	△ △ △	Grey to reddish brown, fine SAND and SILT, some Weathered Bedrock and Clay; moist.			Collect sample 2B6(20-25) for SVOCs, Pesticides, Herbicides, PCBs, Metals, RCRA Characteristics, Cyanide, Mercury, Hex/Tri Chromium.
<b>25</b>	△ △ △	Green, WEATHERED BEDROCK, some medium to fine Sand; moist.			
.....	△ △ △	Grey to reddish brown, fine SAND and SILT, some Weathered Bedrock and Clay; moist.			Collect sample 2B6(25-26) for VOCs, NJEPH.
.....	△ △ △			Collect sample 2B6(25-30) for SVOCs, Pesticides, Herbicides, PCBs, Metals, RCRA Characteristics, Cyanide, Mercury, Hex/Tri Chromium.	
.....	△ △ △				Bedrock encountered at 30 ft bls.
<b>30</b>	△ △ △			<b>30</b>	

BORING/FEET 2611.0002Y000\_PHASE2.GPJ ROUX.GDT 5/29/19



ROUX ASSOCIATES, INC.  
Environmental Consulting  
& Management

209 Shafter Street  
Islandia, NY 11749  
Telephone: (631) 232-2600  
Fax: (631) 232-9898

### SOIL BORING LOG

WELL NO. <b>2B7</b>	NORTHING <b>Not Measured</b>	EASTING <b>Not Measured</b>
PROJECT NO./NAME <b>2611.0002Y000 / Spofford</b>		LOCATION <b>1221 Spofford Ave</b>
APPROVED BY <b>L. Dolginko</b>	LOGGED BY <b>M. Todaro</b>	<b>Bronx, NY</b>
DRILLING CONTRACTOR/DRILLER <b>Russo Demolition / Excavator</b>		GEOGRAPHIC AREA <b>Building 2B</b>
DRILL BIT DIAMETER/TYPE <b>Excavator Bucket /</b>	BOREHOLE DIAMETER <b>Test Pit</b>	DRILLING EQUIPMENT/METHOD <b>Excavator / Test Pit</b>
LAND SURFACE ELEVATION <b>Not Measured</b>	DEPTH TO WATER <b>Not Measured</b>	SAMPLING METHOD <b>Test Pit</b>
		START-FINISH DATE <b>5/7/19-5/7/19</b>
		BACKFILL <b>Soil Cuttings</b>

Depth, feet	Graphic Log	Visual Description	Blow Counts per 6"	PID Values (ppm)	REMARKS	
	△ △ △	Brown, fine Gravel, some medium to coarse SAND, little Asphalt, Brick, and Debris (fill); moist.		8.9	Collect sample 2B7(0-1) for VOCs, NJEPH.	
	△ △ △			14.6	Collect sample 2B7(0-5) for SVOCs, Pesticides, Herbicides, PCBs, Metals, RCRA Characteristics, Cyanide, Mercury, Hex/Tri Chromium.	
	△ △ △			37.2		
	△ △ △			22.1		
<u>5</u>	△ △ △					<u>5</u>
	△ △ △					Collect sample 2B7(5-6) for VOCs, NJEPH.
	△ △ △				18.4	
	△ △ △					Collect sample 2B7(5-10) for SVOCs, Pesticides, Herbicides, PCBs, Metals, RCRA Characteristics, Cyanide, Mercury, Hex/Tri Chromium.
	△ △ △				33.1	
<u>10</u>	△ △ △					<u>10</u>
	△ △ △					Collect sample 2B7(10-11) for VOCs, NJEPH.
	△ △ △				8.0	
	△ △ △					Collect sample 2B7(10-15) for SVOCs, Pesticides, Herbicides, PCBs, Metals, RCRA Characteristics, Cyanide, Mercury, Hex/Tri Chromium.
<u>15</u>	△ △ △					<u>15</u>
	△ △ △		Brown, fine Gravel, some Bedrock and medium to coarse SAND, little Asphalt, Brick, and Debris (fill); moist.			
	△ △ △				Bedrock encountered at 17 ft bls.	

BORING/FEET 2611.0002Y000\_PHASE2.GPJ ROUX.GDT 5/29/19



ROUX ASSOCIATES, INC.  
Environmental Consulting  
& Management

209 Shafter Street  
Islandia, NY 11749  
Telephone: (631) 232-2600  
Fax: (631) 232-9898

# SOIL BORING LOG

WELL NO. <b>2B8</b>	NORTHING <b>Not Measured</b>	EASTING <b>Not Measured</b>
PROJECT NO./NAME <b>2611.0002Y000 / Spofford</b>		LOCATION <b>1221 Spofford Ave</b>
APPROVED BY <b>L. Dolginko</b>	LOGGED BY <b>M. Todaro</b>	<b>Bronx, NY</b>
DRILLING CONTRACTOR/DRILLER <b>Russo Demolition / Excavator</b>		GEOGRAPHIC AREA <b>Building 2B</b>
DRILL BIT DIAMETER/TYPE <b>Excavator Bucket /</b>	BOREHOLE DIAMETER <b>Test Pit</b>	DRILLING EQUIPMENT/METHOD <b>Excavator / Test Pit</b>
LAND SURFACE ELEVATION <b>Not Measured</b>	DEPTH TO WATER <b>Not Measured</b>	BACKFILL <b>Soil Cuttings</b>
SAMPLING METHOD <b>Test Pit</b>		
START-FINISH DATE <b>5/3/19-5/3/19</b>		

Depth, feet	Graphic Log	Visual Description	Blow Counts per 6"	PID Values (ppm)	REMARKS
1	△ △ △	Brown, medium to coarse SAND, some fine Sand, Cobble, Brick, Asphalt, and Debris, little Silt (fill); moist.		0.0	Collect sample 2B8(0-1) for VOCs, NJEPH. 1
2	△ △ △		0.0	2	
3	△ △ △		0.0	Collect sample 2B8(0-5) for SVOCs, Pesticides, Herbicides, PCBs, Metals, RCRA Characteristics, Cyanide, Mercury, Hex/Tri Chromium. 3	
4	△ △ △		4		
5	△ △ △		5		
6	△ △ △		6	Collect sample 2B8(5-6) for VOCs, NJEPH. 6	
7	△ △ △		7		
8	△ △ △		8	Collect sample 2B8(5-10) for SVOCs, Pesticides, Herbicides, PCBs, Metals, RCRA Characteristics, Cyanide, Mercury, Hex/Tri Chromium. 8	
9	△ △ △		9		
10	△ △ △		10		
11	△ △ △	Brown, medium to coarse SAND, some Bedrock, fine Sand, Cobble, Brick, Asphalt, and Debris, little Silt (fill); moist.	0.0	Collect sample 2B8(10-11) for VOCs, NJEPH. 11	
12	△ △ △		0.0	Collect sample 2B8(10-12) for SVOCs, Pesticides, Herbicides, PCBs, Metals, RCRA Characteristics, Cyanide, Mercury, Hex/Tri Chromium. 12	
					Bedrock encountered at 12 ft bls. 12

BORING/FEET 2611.0002Y000\_PHASE2.GPJ ROUX.GDT 5/29/19



ROUX ASSOCIATES, INC.  
Environmental Consulting  
& Management

209 Shafter Street  
Islandia, NY 11749  
Telephone: (631) 232-2600  
Fax: (631) 232-9898

# SOIL BORING LOG

WELL NO. <b>2B9</b>	NORTHING <b>Not Measured</b>	EASTING <b>Not Measured</b>
PROJECT NO./NAME <b>2611.0002Y000 / Spofford</b>		LOCATION <b>1221 Spofford Ave</b>
APPROVED BY <b>L. Dolginko</b>	LOGGED BY <b>M. Todaro</b>	<b>Bronx, NY</b>
DRILLING CONTRACTOR/DRILLER <b>Russo Demolition / Excavator</b>		GEOGRAPHIC AREA <b>Building 2B</b>
DRILL BIT DIAMETER/TYPE <b>Excavator Bucket /</b>	BOREHOLE DIAMETER <b>Test Pit</b>	DRILLING EQUIPMENT/METHOD <b>Excavator / Test Pit</b>
LAND SURFACE ELEVATION <b>Not Measured</b>	DEPTH TO WATER <b>Not Measured</b>	BACKFILL <b>Soil Cuttings</b>
SAMPLING METHOD <b>Test Pit</b>		
START-FINISH DATE <b>5/7/19-5/7/19</b>		

Depth, feet	Graphic Log	Visual Description	Blow Counts per 6"	PID Values (ppm)	REMARKS
1	△ △ △	Brown, medium to coarse SAND, some Cobble and Gravel, little Asphalt, Brick, and Debris (fill); moist.		0.0	Collect sample 2B9(0-1) for VOCs, NJEPH. <span style="float:right">1</span>
2	△ △ △			0.0	
3	△ △ △			Collect sample 2B9(0-5) for SVOCs, Pesticides, Herbicides, PCBs, Metals, RCRA Characteristics, Cyanide, Mercury, Hex/Tri Chromium. <span style="float:right">3</span>	0.0
4	△ △ △				
5	△ △ △				
6	△ △ △				
7	△ △ △			Collect sample 2B9(5-6) for VOCs, NJEPH. <span style="float:right">6</span>	0.0
8	△ △ △				
9	△ △ △				
10	△ △ △			Collect sample 2B9(5-10) for SVOCs, Pesticides, Herbicides, PCBs, Metals, RCRA Characteristics, Cyanide, Mercury, Hex/Tri Chromium. <span style="float:right">8</span>	0.0
11	△ △ △				
12	△ △ △				
		Brown, medium to coarse SAND, some Bedrock, Cobble and Gravel, little Asphalt, Brick, and Debris (fill); moist.			Collect sample 2B9(10-11) for VOCs, NJEPH. <span style="float:right">11</span> Collect sample 2B9(10-12) for SVOCs, Pesticides, Herbicides, PCBs, Metals, RCRA Characteristics, Cyanide, Mercury, Hex/Tri Chromium. <span style="float:right">12</span> Bedrock encountered at 12 ft bls. <span style="float:right">12</span>

BORING/FEET 2611.0002Y000\_PHASE2.GPJ ROUX.GDT 5/29/19



**ROUX ASSOCIATES, INC.**  
Environmental Consulting  
& Management

209 Shafter Street  
Islandia, NY 11749  
Telephone: (631) 232-2600  
Fax: (631) 232-9898

# SOIL BORING LOG

WELL NO. <b>Reuse-TP-2A3</b>	LATITUDE <b>Not Measured</b>	LONGITUDE <b>Not Measured</b>
PROJECT NO./NAME <b>2611.0002Y000 / Spofford</b>		LOCATION <b>1221 Spofford Ave</b>
APPROVED BY <b>DRAFT</b>	LOGGED BY <b>P. Kilkelly</b>	<b>Bronx, NY</b>
DRILLING CONTRACTOR/DRILLER <b>Russo Demolition / Excavator</b>		GEOGRAPHIC AREA <b>Building 2A</b>
DRILL BIT DIAMETER/TYPE <b>Excavator Bucket /</b>	BOREHOLE DIAMETER <b>Test Pit</b>	DRILLING EQUIPMENT/METHOD <b>Excavator / Test Pit</b>
LAND SURFACE ELEVATION <b>Not Measured</b>	DEPTH TO WATER <b>Not Measured</b>	BACKFILL <b>Soil Cuttings</b>
SAMPLING METHOD <b>Test Pit</b>		
START-FINISH DATE <b>3/26/20-3/26/20</b>		

Depth, feet	Graphic Log	Visual Description	Blow Counts per 6"	PID Values (ppm)	REMARKS
1		Brown, medium to coarse SAND, some Silt, little Brick and Concrete (fill); moist.		0.0	
2		Brown, medium to coarse SAND, some Cobble, little Silt, Brick, and Concrete (fill); moist.			
3		Light brown, medium to coarse SAND, some Silt and Cobble, little Brick and Concrete (fill); moist.			
4					Collect sample TP_2A3(3-4) for VOCs.
5					Green tarp encountered at 5 ft bls.
6					
7		Light brown, fine to medium SAND, some Silt, little Cobble; moist.			Collect sample TP_2A3(6-7) for VOCs.
8					
9					
10					Collect sample TP_2A3(9-10) for VOCs.
11					
12					Collect sample TP_2A3(12-13) for VOCs.
13					End of test pit at 13 ft bls.

BORING/FEET 2611.0002Y000\_PHASE2 - SUPPLEMENTAL WC.GPJ ROUX.GDT 4/16/20



**ROUX ASSOCIATES, INC.**  
Environmental Consulting  
& Management

209 Shafter Street  
Islandia, NY 11749  
Telephone: (631) 232-2600  
Fax: (631) 232-9898

# SOIL BORING LOG

WELL NO. <b>Reuse-TP-2B10</b>	LATITUDE <b>Not Measured</b>	LONGITUDE <b>Not Measured</b>		
PROJECT NO./NAME <b>2611.0002Y000 / Spofford</b>		LOCATION <b>1221 Spofford Ave</b>		
APPROVED BY <b>DRAFT</b>	LOGGED BY <b>P. Kilkelly</b>	<b>Bronx, NY</b>		
DRILLING CONTRACTOR/DRILLER <b>Russo Demolition / Excavator</b>		GEOGRAPHIC AREA <b>Building 2B</b>		
DRILL BIT DIAMETER/TYPE <b>Excavator Bucket /</b>	BOREHOLE DIAMETER <b>Test Pit</b>	DRILLING EQUIPMENT/METHOD <b>Excavator / Test Pit</b>	SAMPLING METHOD <b>Test Pit</b>	START-FINISH DATE <b>3/26/20-3/26/20</b>
LAND SURFACE ELEVATION <b>Not Measured</b>	DEPTH TO WATER <b>Not Measured</b>	BACKFILL <b>Soil Cuttings</b>		

Depth, feet	Graphic Log	Visual Description	Blow Counts per 6"	PID Values (ppm)	REMARKS
1		Brown to grey, medium to coarse SAND and CRUSHED CONCRETE, little Brick, trace wood (fill); dry.			
2				0.0	
3		Light brown, fine to medium SAND, little Silt and Cobble; dry.			
4				0.0	
5				0.0	
6		Light brown, fine to medium SAND, little Cobble, trace silt; dry.			
7		Light brown, fine to medium SAND and SILT, little Cobble; dry.		0.0	Collect sample TP_2B10(6-7) for VOCs.
8				0.0	
9				0.0	Collect sample TP_2B10(8-9) for VOCs.
10		BEDROCK.		0.0	Collect sample TP_2B10(9-10) for VOCs. Bedrock encountered at 10.5 ft bls.

BORING/FEET 2611.0002Y000\_PHASE2 - SUPPLEMENTAL WC.GPJ ROUX.GDT 4/16/20



**ROUX ASSOCIATES, INC.**  
 Environmental Consulting  
 & Management

209 Shafter Street  
 Islandia, NY 11749  
 Telephone: (631) 232-2600  
 Fax: (631) 232-9898

# SOIL BORING LOG

WELL NO. <b>Reuse-TP-2B7</b>	LATITUDE <b>Not Measured</b>	LONGITUDE <b>Not Measured</b>		
PROJECT NO./NAME <b>2611.0002Y000 / Spofford</b>		LOCATION <b>1221 Spofford Ave</b>		
APPROVED BY <b>DRAFT</b>	LOGGED BY <b>P. Kilkelly</b>	<b>Bronx, NY</b>		
DRILLING CONTRACTOR/DRILLER <b>Russo Demolition / Excavator</b>		GEOGRAPHIC AREA <b>Building 2B</b>		
DRILL BIT DIAMETER/TYPE <b>Excavator Bucket /</b>	BOREHOLE DIAMETER <b>Test Pit</b>	DRILLING EQUIPMENT/METHOD <b>Excavator / Test Pit</b>	SAMPLING METHOD <b>Test Pit</b>	START-FINISH DATE <b>3/26/20-3/26/20</b>
LAND SURFACE ELEVATION <b>Not Measured</b>	DEPTH TO WATER <b>Not Measured</b>	BACKFILL <b>Soil Cuttings</b>		

Depth, feet	Graphic Log	Visual Description	Blow Counts per 6"	PID Values (ppm)	REMARKS
1		Light brown, fine to medium SAND, some Silt, little Cobble, trace brick and concrete (fill); dry.			
2					
3					
4					
5		Light brown to grey, fine to medium SAND, some Silt and Cobble; dry.			
6					
7		Light brown to brown, fine to medium SAND, some Silt, little Clay and Boulder; dry.			
8					
9					
10		Light brown to grey, fine to medium SAND, some Weathered Bedrock, little Silt; dry.			

BORING/FEET 2611.0002Y000\_PHASE2 - SUPPLEMENTAL WC.GPJ ROUX.GDT 4/16/20

G

0.0

0.0

0.0

0.0

0.0

Collect sample TP\_2B7(5-6) for VOCs.

Collect sample TP\_2B7(8-9) for VOCs.

End of test pit at 10 ft bls.





**ROUX ASSOCIATES, INC.**  
Environmental Consulting  
& Management

209 Shafter Street  
Islandia, NY 11749  
Telephone: (631) 232-2600  
Fax: (631) 232-9898

## SOIL BORING LOG

WELL NO. <b>Reuse-TP-2B8</b>	LATITUDE <b>Not Measured</b>	LONGITUDE <b>Not Measured</b>
PROJECT NO./NAME <b>2611.0002Y000 / Spofford</b>		LOCATION <b>1221 Spofford Ave</b>
APPROVED BY <b>DRAFT</b>	LOGGED BY <b>P. Kilkelly</b>	<b>Bronx, NY</b>
DRILLING CONTRACTOR/DRILLER <b>Russo Demolition / Excavator</b>		GEOGRAPHIC AREA <b>Building 2B</b>
DRILL BIT DIAMETER/TYPE <b>Excavator Bucket /</b>	BOREHOLE DIAMETER <b>Test Pit</b>	DRILLING EQUIPMENT/METHOD <b>Excavator / Test Pit</b>
LAND SURFACE ELEVATION <b>Not Measured</b>	DEPTH TO WATER <b>Not Measured</b>	BACKFILL <b>Soil Cuttings</b>
SAMPLING METHOD <b>Test Pit</b>		
START-FINISH DATE <b>3/26/20-3/26/20</b>		

Depth, feet	Graphic Log	Visual Description	Blow Counts per 6"	PID Values (ppm)	REMARKS
1		Brown to grey, medium to coarse SAND and CRUSHED CONCRETE, little Brick, trace wood (fill); dry.			
2				0.5	
3					
4				0.0	
5		Light brown, medium to coarse SAND, little Silt, trace brick (fill); dry.			
6				0.0	
7					Collect sample TP_2B8(6-7) for VOCs.
8					
9				0.0	
10					Collect sample TP_2B8(9-10) for VOCs.
11				0.0	
12		Light brown, fine to medium SAND, little Clay and Weathered Bedrock; dry.			End of test pit at 12 ft bls.

BORING/FEET 2611.0002Y000\_PHASE2 - SUPPLEMENTAL WC.GPJ ROUX.GDT 4/16/20



**ROUX ASSOCIATES, INC.**  
Environmental Consulting  
& Management

209 Shafter Street  
Islandia, NY 11749  
Telephone: (631) 232-2600  
Fax: (631) 232-9898

# SOIL BORING LOG

WELL NO. <b>Reuse-TP-2B9</b>	LATITUDE <b>Not Measured</b>	LONGITUDE <b>Not Measured</b>
PROJECT NO./NAME <b>2611.0002Y000 / Spofford</b>		LOCATION <b>1221 Spofford Ave</b>
APPROVED BY <b>DRAFT</b>	LOGGED BY <b>P. Kilkelly</b>	<b>Bronx, NY</b>
DRILLING CONTRACTOR/DRILLER <b>Russo Demolition / Excavator</b>		GEOGRAPHIC AREA <b>Building 2B</b>
DRILL BIT DIAMETER/TYPE <b>Excavator Bucket /</b>	BOREHOLE DIAMETER <b>Test Pit</b>	DRILLING EQUIPMENT/METHOD <b>Excavator / Test Pit</b>
LAND SURFACE ELEVATION <b>Not Measured</b>	DEPTH TO WATER <b>Not Measured</b>	BACKFILL <b>Soil Cuttings</b>
SAMPLING METHOD <b>Test Pit</b>		
START-FINISH DATE <b>3/26/20-3/26/20</b>		

Depth, feet	Graphic Log	Visual Description	Blow Counts per 6"	PID Values (ppm)	REMARKS
1		Brown to grey, medium to coarse SAND and CRUSHED CONCRETE (fill); dry.		0.0	
2		Light brown, fine to medium SAND, little Silt and Cobble; dry.			
3				0.0	
4					
5					
6				0.0	
7		Light brown, fine to medium SAND and SILT, little Cobble; dry.			Collect sample TP_2B9(6-7) for VOCs.
8					
9				0.0	Collect sample TP_2B9(8-9) for VOCs.
10		BEDROCK.		0.0	Collect sample TP_2B9(9-10) for VOCs.
					End of test pit at 10.5 ft bls.

BORING/FEET 2611.0002Y000\_PHASE2 - SUPPLEMENTAL WC.GPJ ROUX.GDT 4/16/20



**ROUX ASSOCIATES, INC.**  
Environmental Consulting  
& Management

209 Shafter Street  
Islandia, NY 11749  
Telephone: (631) 232-2600  
Fax: (631) 232-9898

## SOIL BORING LOG

WELL NO. <b>TP- 2B6</b>	LATITUDE <b>Not Measured</b>	LONGITUDE <b>Not Measured</b>
PROJECT NO./NAME <b>2611.0002Y000 / Spofford</b>	LOCATION <b>1221 Spofford Ave</b>	
APPROVED BY <b>DRAFT</b>	LOGGED BY <b>P. Rubenbauer</b>	<b>Bronx, NY</b>
DRILLING CONTRACTOR/DRILLER <b>Brookside Environmental / Excavator</b>	GEOGRAPHIC AREA <b>Building 2B</b>	
DRILL BIT DIAMETER/TYPE <b>Excavator Bucket /</b>	BOREHOLE DIAMETER <b>Test Pit</b>	DRILLING EQUIPMENT/METHOD <b>Excavator / Test Pit</b>
LAND SURFACE ELEVATION <b>Not Measured</b>	DEPTH TO WATER <b>Not Measured</b>	BACKFILL <b>Soil Cuttings</b>
SAMPLING METHOD <b>Test Pit</b>		START-FINISH DATE <b>2/7/20-2/7/20</b>

Depth, feet	Graphic Log	Visual Description	Blow Counts per 6"	PID Values (ppm)	REMARKS
1		Brown to grey, fine to coarse SAND, some Crushed Concrete, fine to coarse Gravel and Asphalt, little Wood, Metal, and Silt (fill); moist.			
2					
3					
4					
5					
6				G	
7					
8					
9					
10		Brown to dark brown, fine to coarse SAND, some fine to coarse Gravel, little Concrete, Metal, and Silt (fill); moist.			Green tarp encountered at 9 ft bls.
11		Brown to dark brown, fine to coarse SAND, some fine to coarse Gravel, little Silt; moist.			
12					End of test pit at 12 ft bls.

BORING/FEET 2611.0002Y000\_PHASE2 - SUPPLEMENTAL WC.GPJ ROUX.GDT 4/16/20



**ROUX ASSOCIATES, INC.**  
Environmental Consulting  
& Management

209 Shafter Street  
Islandia, NY 11749  
Telephone: (631) 232-2600  
Fax: (631) 232-9898

## SOIL BORING LOG

WELL NO. <b>TP-2A1</b>	LATITUDE <b>Not Measured</b>	LONGITUDE <b>Not Measured</b>		
PROJECT NO./NAME <b>2611.0002Y000 / Spofford</b>		LOCATION <b>1221 Spofford Ave</b>		
APPROVED BY <b>DRAFT</b>	LOGGED BY <b>P. Rubenbauer</b>	<b>Bronx, NY</b>		
DRILLING CONTRACTOR/DRILLER <b>Brookside Environmental / Excavator</b>		GEOGRAPHIC AREA <b>Building 2A</b>		
DRILL BIT DIAMETER/TYPE <b>Excavator Bucket /</b>	BOREHOLE DIAMETER <b>Test Pit</b>	DRILLING EQUIPMENT/METHOD <b>Excavator / Test Pit</b>	SAMPLING METHOD <b>Test Pit</b>	START-FINISH DATE <b>2/7/20-2/7/20</b>
LAND SURFACE ELEVATION <b>Not Measured</b>	DEPTH TO WATER <b>Not Measured</b>	BACKFILL <b>Soil Cuttings</b>		

Depth, feet	Graphic Log	Visual Description	Blow Counts per 6"	PID Values (ppm)	REMARKS
1		Brown, fine to coarse SAND and CRUSHED CONCRETE, some Brick, Concrete, Asphalt, and Metal, little Silt and fine to coarse Gravel, trace cobble (fill); moist.			
2		Light brown, fine to medium SAND, some coarse Sand and Silt, little Cobble and fine to medium Gravel; moist.			
3		Brown to light brown, fine to coarse SAND and WEATHERED BEDROCK, little medium to coarse Gravel; moist.			
4		Brown to light brown, fine to coarse SAND and WEATHERED BEDROCK, little medium to coarse Gravel; wet.			
5		BEDROCK.			Bedrock encountered at 4.5 ft bls.

BORING/FEET 2611.0002Y000\_PHASE2 - SUPPLEMENTAL WC.GPJ ROUX.GDT 4/16/20



**ROUX ASSOCIATES, INC.**  
Environmental Consulting  
& Management

209 Shafter Street  
Islandia, NY 11749  
Telephone: (631) 232-2600  
Fax: (631) 232-9898

# SOIL BORING LOG

WELL NO. <b>TP-2A2</b>	LATITUDE <b>Not Measured</b>	LONGITUDE <b>Not Measured</b>
PROJECT NO./NAME <b>2611.0002Y000 / Spofford</b>		LOCATION <b>1221 Spofford Ave</b>
APPROVED BY <b>DRAFT</b>	LOGGED BY <b>P. Rubenbauer</b>	<b>Bronx, NY</b>
DRILLING CONTRACTOR/DRILLER <b>Brookside Environmental / Excavator</b>		GEOGRAPHIC AREA <b>Building 2A</b>
DRILL BIT DIAMETER/TYPE <b>Excavator Bucket /</b>	BOREHOLE DIAMETER <b>Test Pit</b>	DRILLING EQUIPMENT/METHOD <b>Excavator / Test Pit</b>
LAND SURFACE ELEVATION <b>Not Measured</b>	DEPTH TO WATER <b>Not Measured</b>	BACKFILL <b>Soil Cuttings</b>
SAMPLING METHOD <b>Test Pit</b>		
START-FINISH DATE <b>2/6/20-2/6/20</b>		

Depth, feet	Graphic Log	Visual Description	Blow Counts per 6"	PID Values (ppm)	REMARKS
1		Brown to grey, fine to coarse SAND and CRUSHED CONCRETE, some Brick, little Asphalt and Metal (fill); moist.			
2					
3					Collect sample 2A2(2-3) for VOCs, NJEPH.
4					
5					
6		Brown, fine to coarse SAND, some Brick, Concrete, Asphalt, Metal, and Silt (fill); moist.			Green tarp encountered at 5 ft bls.
7		CONCRETE.			Collect sample 2A2(2-7) for SVOCs, Pesticides, Herbicides, PCBs, Metals, RCRA Characteristics, Cyanide, Mercury, Hex/Tri Chromium.
8		CRUSHED CONCRETE and BEDROCK.			
9					Bedrock encountered at 9 ft bls.

BORING/FEET 2611.0002Y000\_PHASE2 - SUPPLEMENTAL WC.GPJ ROUX.GDT 4/16/20



ROUX ASSOCIATES, INC.  
Environmental Consulting  
& Management

209 Shafter Street  
Islandia, NY 11749  
Telephone: (631) 232-2600  
Fax: (631) 232-9898

# SOIL BORING LOG

WELL NO. <b>TP-2A3</b>	LATITUDE <b>Not Measured</b>	LONGITUDE <b>Not Measured</b>
PROJECT NO./NAME <b>2611.0002Y000 / Spofford</b>		LOCATION <b>1221 Spofford Ave</b>
APPROVED BY <b>DRAFT</b>	LOGGED BY <b>P. Rubenbauer</b>	<b>Bronx, NY</b>
DRILLING CONTRACTOR/DRILLER <b>Brookside Environmental / Excavator</b>		GEOGRAPHIC AREA <b>Building 2A</b>
DRILL BIT DIAMETER/TYPE <b>Excavator Bucket /</b>	BOREHOLE DIAMETER <b>Test Pit</b>	DRILLING EQUIPMENT/METHOD <b>Excavator / Test Pit</b>
LAND SURFACE ELEVATION <b>Not Measured</b>	DEPTH TO WATER <b>Not Measured</b>	START-FINISH DATE <b>2/6/20-2/6/20</b>
		BACKFILL <b>Soil Cuttings</b>

Depth, feet	Graphic Log	Visual Description	Blow Counts per 6"	PID Values (ppm)	REMARKS
1		Brown, fine to coarse SAND and CRUSHED CONCRETE, some Brick, Asphalt, and fine to medium Gravel, trace silt and metal (fill); moist.		0.0	..1
2		Brown to light brown, fine to medium SAND, some Silt, Brick, Concrete, and Asphalt, little Metal and fine to coarse Gravel, (fill); moist.			Green tarp encountered at 1.5 ft bls. ..2
3					Collect sample 2A3 (0-2) Sieve for Grain Size. ..3
4					Collect sample 2A3(2-3) for VOCs, NJEPH. ..4
5				0.0	..5
6		Light brown, fine to coarse SAND, some fine to coarse Gravel, little Silt; moist.		0.0	Collect sample 2A3(2-7) for SVOCs, Pesticides, Herbicides, PCBs, Metals, RCRA Characteristics, Cyanide, Mercury, Hex/Tri Chromium. ..6
7		Light brown, fine to coarse SAND, some fine to coarse Gravel, little Silt and Boulder; moist.			Collect sample 2A3(7-8) for VOCs, NJEPH. ..7
8					..8
9					..9
10					Collect sample 2A3(7-14) for SVOCs, Pesticides, Herbicides, PCBs, Metals, RCRA Characteristics, Cyanide, Mercury, Hex/Tri Chromium. ..10
11					..11
12					..12
13					..13
14				0.0	End of test pit at 14 ft bls. ..14

BORING/FEET 2611.0002Y000\_PHASE2 - SUPPLEMENTAL WC.GPJ ROUX.GDT 4/16/20



**ROUX ASSOCIATES, INC.**  
Environmental Consulting  
& Management

209 Shafter Street  
Islandia, NY 11749  
Telephone: (631) 232-2600  
Fax: (631) 232-9898

## SOIL BORING LOG

WELL NO. <b>TP-2B1</b>	LATITUDE <b>Not Measured</b>	LONGITUDE <b>Not Measured</b>
PROJECT NO./NAME <b>2611.0002Y000 / Spofford</b>	LOCATION <b>1221 Spofford Ave</b>	
APPROVED BY <b>DRAFT</b>	LOGGED BY <b>P. Rubenbauer</b>	<b>Bronx, NY</b>
DRILLING CONTRACTOR/DRILLER <b>Brookside Environmental / Excavator</b>	GEOGRAPHIC AREA <b>Building 2B</b>	
DRILL BIT DIAMETER/TYPE <b>Excavator Bucket /</b>	BOREHOLE DIAMETER <b>Test Pit</b>	DRILLING EQUIPMENT/METHOD <b>Excavator / Test Pit</b>
LAND SURFACE ELEVATION <b>Not Measured</b>	DEPTH TO WATER <b>Not Measured</b>	BACKFILL <b>Soil Cuttings</b>
SAMPLING METHOD <b>Test Pit</b>		START-FINISH DATE <b>2/7/20-2/7/20</b>

Depth, feet	Graphic Log	Visual Description	Blow Counts per 6"	PID Values (ppm)	REMARKS
1		Brown to grey, fine to coarse SAND, some Crushed Concrete, Metal, and Asphalt, little Brick, fine to coarse Gravel, and Silt (fill); moist.			
2					
3		Light brown to brown, fine to medium SAND, little fine Gravel, Asphalt, Crushed Concrete, and Silt, (fill); moist.			
4					
5				G	
6		Light brown to brown, fine to medium SAND, some coarse Sand and Silt; moist.			
7					
8					Collect sample 2B1(5-10)_Sieve for Grain Size.
9					End of test pit at 9.5 ft bls.

BORING/FEET 2611.0002Y000\_PHASE2 - SUPPLEMENTAL WC.GPJ ROUX.GDT 4/16/20



**ROUX ASSOCIATES, INC.**  
Environmental Consulting  
& Management

209 Shafter Street  
Islandia, NY 11749  
Telephone: (631) 232-2600  
Fax: (631) 232-9898

## SOIL BORING LOG

WELL NO. <b>TP-2B10</b>	LATITUDE <b>Not Measured</b>	LONGITUDE <b>Not Measured</b>		
PROJECT NO./NAME <b>2611.0002Y000 / Spofford</b>		LOCATION <b>1221 Spofford Ave</b>		
APPROVED BY <b>DRAFT</b>	LOGGED BY <b>P. Rubenbauer</b>	<b>Bronx, NY</b>		
DRILLING CONTRACTOR/DRILLER <b>Brookside Environmental / Excavator</b>		GEOGRAPHIC AREA <b>Building 2B</b>		
DRILL BIT DIAMETER/TYPE <b>Excavator Bucket /</b>	BOREHOLE DIAMETER <b>Test Pit</b>	DRILLING EQUIPMENT/METHOD <b>Excavator / Test Pit</b>	SAMPLING METHOD <b>Test Pit</b>	START-FINISH DATE <b>2/6/20-2/6/20</b>
LAND SURFACE ELEVATION <b>Not Measured</b>	DEPTH TO WATER <b>Not Measured</b>	BACKFILL <b>Soil Cuttings</b>		

Depth, feet	Graphic Log	Visual Description	Blow Counts per 6"	PID V a l u e s (ppm)	REMARKS
1		Brown, fine to coarse SAND and BRICK, CONCRETE, and ASPHALT, some fine Gravel, little Silt (fill); moist.			
2				0.0	
3					
4				0.2	
5		Light brown to brown, fine to medium SAND and SILT, some coarse Sand, little fine to coarse Gravel, trace cobble; moist.			Slight petroleum odor observed.
6		Light brown to brown, fine to medium SAND and SILT, some coarse Sand, little Boulder and fine to coarse Gravel, trace cobble; moist.		G	
7					
8		Light brown to grey, medium to coarse SAND, some Weathered Bedrock and fine to coarse Gravel, little Silt; moist.			
9				0.0	
10		Grey, WEATHERED BEDROCK; moist.			
11					Collect sample 2B10(10-12)_Sieve for Grain Size.
12					End of test pit at 12 ft bls.

BORING/FEET 2611.0002Y000\_PHASE2 - SUPPLEMENTAL WC.GPJ ROUX.GDT 4/16/20





**ROUX ASSOCIATES, INC.**  
*Environmental Consulting  
 & Management*

209 Shafter Street  
 Islandia, NY 11749  
 Telephone: (631) 232-2600  
 Fax: (631) 232-9898

## SOIL BORING LOG

WELL NO. <b>TP-2B11</b>	LATITUDE <b>Not Measured</b>	LONGITUDE <b>Not Measured</b>		
PROJECT NO./NAME <b>2611.0002Y000 / Spofford</b>		LOCATION <b>1221 Spofford Ave</b>		
APPROVED BY <b>DRAFT</b>	LOGGED BY <b>P. Rubenbauer</b>	<b>Bronx, NY</b>		
DRILLING CONTRACTOR/DRILLER <b>Brookside Environmental / Excavator</b>		GEOGRAPHIC AREA <b>Building 2B</b>		
DRILL BIT DIAMETER/TYPE <b>Excavator Bucket /</b>	BOREHOLE DIAMETER <b>Test Pit</b>	DRILLING EQUIPMENT/METHOD <b>Excavator / Test Pit</b>	SAMPLING METHOD <b>Test Pit</b>	START-FINISH DATE <b>2/7/20-2/7/20</b>
LAND SURFACE ELEVATION <b>Not Measured</b>	DEPTH TO WATER <b>Not Measured</b>	BACKFILL <b>Soil Cuttings</b>		

Depth, feet	Graphic Log	Visual Description	Blow Counts per 6"	PID Values (ppm)	REMARKS
1...		Brown to grey, fine to coarse SAND and fine to medium GRAVEL, some Crushed Concrete, Brick, Asphalt, and Wood, trace silt (fill); moist.			1
2...		Light brown to brown, fine to medium SAND, some fine to coarse Gravel, little Silt and Cobble; moist.		G	2
3...					3
4...					4
End of test pit at 4.5 ft bls.					

BORING/FEET 2611.0002Y000\_PHASE2 - SUPPLEMENTAL WC.GPJ ROUX.GDT 4/16/20



**ROUX ASSOCIATES, INC.**  
Environmental Consulting  
& Management

209 Shafter Street  
Islandia, NY 11749  
Telephone: (631) 232-2600  
Fax: (631) 232-9898

# SOIL BORING LOG

WELL NO. <b>TP-2B2</b>	LATITUDE <b>Not Measured</b>	LONGITUDE <b>Not Measured</b>		
PROJECT NO./NAME <b>2611.0002Y000 / Spofford</b>		LOCATION <b>1221 Spofford Ave</b>		
APPROVED BY <b>DRAFT</b>	LOGGED BY <b>P. Rubenbauer</b>	<b>Bronx, NY</b>		
DRILLING CONTRACTOR/DRILLER <b>Brookside Environmental / Excavator</b>		GEOGRAPHIC AREA <b>Building 2B</b>		
DRILL BIT DIAMETER/TYPE <b>Excavator Bucket /</b>	BOREHOLE DIAMETER <b>Test Pit</b>	DRILLING EQUIPMENT/METHOD <b>Excavator / Test Pit</b>	SAMPLING METHOD <b>Test Pit</b>	START-FINISH DATE <b>2/7/20-2/7/20</b>
LAND SURFACE ELEVATION <b>Not Measured</b>	DEPTH TO WATER <b>Not Measured</b>	BACKFILL <b>Soil Cuttings</b>		

Depth, feet	Graphic Log	Visual Description	Blow Counts per 6"	PID Values (ppm)	REMARKS
1		Brown to grey, fine to coarse SAND and CRUSHED CONCRETE, some Brick and Silt, little Asphalt, Metal, and fine to coarse Gravel (fill); moist.			
2					
3		Brown to grey, fine to coarse SAND, some fine to coarse Gravel, little Concrete and Brick (fill); moist.			
4					
5					
6					
7					
8		Brown to light brown, fine to medium SAND, some coarse Sand, little fine to medium Gravel and Silt; moist.			Green tarp encountered at 7.5 ft bls. Collect sample 2B2(5-10)_Sieve for Grain Size.
9		Brown to light brown, fine to medium SAND, some coarse Sand, fine to medium Gravel and Silt, little Weathered Bedrock; moist.			
10					End of test pit at 10 ft bls.

BORING/FEET 2611.0002Y000\_PHASE2 - SUPPLEMENTAL WC.GPJ ROUX.GDT 4/16/20



**ROUX ASSOCIATES, INC.**  
*Environmental Consulting  
 & Management*

209 Shafter Street  
 Islandia, NY 11749  
 Telephone: (631) 232-2600  
 Fax: (631) 232-9898

# SOIL BORING LOG

WELL NO. <b>TP-2B5</b>	LATITUDE <b>Not Measured</b>	LONGITUDE <b>Not Measured</b>
PROJECT NO./NAME <b>2611.0002Y000 / Spofford</b>		LOCATION <b>1221 Spofford Ave</b>
APPROVED BY <b>DRAFT</b>	LOGGED BY <b>P. Rubenbauer</b>	<b>Bronx, NY</b>
DRILLING CONTRACTOR/DRILLER <b>Brookside Environmental / Excavator</b>		GEOGRAPHIC AREA <b>Building 2B</b>
DRILL BIT DIAMETER/TYPE <b>Excavator Bucket /</b>	BOREHOLE DIAMETER <b>Test Pit</b>	DRILLING EQUIPMENT/METHOD <b>Excavator / Test Pit</b>
LAND SURFACE ELEVATION <b>Not Measured</b>	DEPTH TO WATER <b>Not Measured</b>	BACKFILL <b>Soil Cuttings</b>
SAMPLING METHOD <b>Test Pit</b>		
START-FINISH DATE <b>2/6/20-2/6/20</b>		

Depth, feet	Graphic Log	Visual Description	Blow Counts per 6"	PID Values (ppm)	REMARKS
1		Brown to dark brown, fine to coarse SAND, some Concrete, Brick, Asphalt, and Crushed Concrete, little Silt (fill); moist.			
2		Brown to dark brown, fine to coarse SAND, some Concrete, Brick, Asphalt, Metal, and Wood, little Silt (fill); moist.		0.0	Green tarp encountered at 2 ft bls.
3					Collect sample 2B5(0-5)_Sieve for Grain Size.
4			G		
5					
6					
7		Grey, WEATHERED BEDROCK; moist.			
8		BEDROCK.			Bedrock encountered at 8 ft bls.

BORING/FEET 2611.0002Y000\_PHASE2 - SUPPLEMENTAL WC.GPJ ROUX.GDT 4/16/20



**ROUX ASSOCIATES, INC.**  
Environmental Consulting  
& Management

209 Shafter Street  
Islandia, NY 11749  
Telephone: (631) 232-2600  
Fax: (631) 232-9898

## SOIL BORING LOG

WELL NO. <b>TP-2B9</b>	LATITUDE <b>Not Measured</b>	LONGITUDE <b>Not Measured</b>
PROJECT NO./NAME <b>2611.0002Y000 / Spofford</b>		LOCATION <b>1221 Spofford Ave</b>
APPROVED BY <b>DRAFT</b>	LOGGED BY <b>P. Rubenbauer</b>	<b>Bronx, NY</b>
DRILLING CONTRACTOR/DRILLER <b>Brookside Environmental / Excavator</b>		GEOGRAPHIC AREA <b>Building 2B</b>
DRILL BIT DIAMETER/TYPE <b>Excavator Bucket /</b>	BOREHOLE DIAMETER <b>Test Pit</b>	DRILLING EQUIPMENT/METHOD <b>Excavator / Test Pit</b>
LAND SURFACE ELEVATION <b>Not Measured</b>	DEPTH TO WATER <b>Not Measured</b>	BACKFILL <b>Soil Cuttings</b>
SAMPLING METHOD <b>Test Pit</b>		
START-FINISH DATE <b>2/6/20-2/6/20</b>		

Depth, feet	Graphic Log	Visual Description	Blow Counts per 6"	PID Values (ppm)	REMARKS
1		Brown, fine to coarse SAND and CRUSHED CONCRETE, some fine to coarse Gravel, little Silt (fill); moist.		0.0	
2		Brown to dark brown, fine to coarse SAND, BRICK, ASPHALT, and CONCRETE, little Wood, Silt and Metal (fill); moist.		0.0	
3		Light brown, fine to medium SAND, some coarse Sand, little Silt and fine to medium Gravel; moist.		0.0	
4		Light brown, fine to medium SAND, little coarse Sand, Silt, and Cobble; moist.		0.0	
5					
6					
7					
8		Light brown, fine to medium SAND, little coarse Sand, Silt, Cobble, and Boulder; moist.			Collect sample 2B9(5-10)_ Sieve for Grain Size.
9					
10					End of test pit at 10 ft bls.

BORING/FEET 2611.0002Y000\_PHASE2 - SUPPLEMENTAL WC.GPJ ROUX.GDT 4/16/20

**APPENDIX E**

Monitoring Well Boring and Construction Logs



ROUX ASSOCIATES, INC.  
Environmental Consulting  
& Management

209 Shafter Street  
Islandia, NY 11749  
Telephone: (631) 232-2600  
Fax: (631) 232-9898

# WELL CONSTRUCTION LOG

WELL NO. <b>RXMW-1</b>	NORTHING <b>236040.391</b>	EASTING <b>1014369.914</b>
PROJECT NO./NAME <b>2611.0002Y002 / Spofford Avenue</b>		LOCATION <b>1221 Spofford Avenue</b>
APPROVED BY <b>J. Wills</b>	LOGGED BY <b>Rachel Miller</b>	<b>Bronx, New York</b>
DRILLING CONTRACTOR/DRILLER <b>Aquifer Drilling and Testing / German H.</b>		GEOGRAPHIC AREA <b>Tiffany Street Sidewalk</b>
DRILL BIT DIAMETER/TYPE <b>4" / Drive Sampler</b>	BOREHOLE DIAMETER <b>4-inches</b>	DRILLING EQUIPMENT/METHOD <b>8140LC / Rotosonic</b>
CASING MAT./DIA. <b>PVC / 2-inch</b>	SCREEN: <b>TYPE Slotted</b>	SAMPLING METHOD <b>Sonic Core</b>
ELEVATION OF: GROUND SURFACE (Feet)		START-FINISH DATE <b>6/15/18-6/15/18</b>
TOP OF WELL CASING <b>34.91</b>		TOTAL LENGTH <b>10.0ft</b>
TOP & BOTTOM SCREEN <b>/</b>		DIA. <b>2-inch</b>
GRAVEL PACK SIZES <b>More #2</b>		SLOT SIZE <b>20-slot</b>

Depth, feet	Graphic Log	Visual Description	Blow Counts per 6"	PID Values (ppm)	REMARKS
0	Concrete.	CONCRETE.		0.0	Hand cleared to 5 ft bls.
	Grout.	Dark brown, medium to coarse SAND, some fine Sand, little Silt, trace gravel; dry.			Sample RXMW-1_0-2 collected for TCL VOCs, TCL SVOCs, Pesticides, Herbicides, TAL Metals, Hex Chromium, PCBs, and Total Cyanide.
	Bentonite pellets.	Light brown, fine to medium SAND and SILT, some medium to coarse Sand, trace clay and gravel; dry.	G	0.0	
5	— More #2 sand.	Light brown, medium to coarse SAND and SILT, little Clay, trace gravel; moist.		0.2	Sample RXMW-1_7-11 collected for TCL VOCs, TCL SVOCs, Pesticides, Herbicides, TAL Metals, Hex Chromium, PCBs, and Total Cyanide.
		Light grey, fine to medium SAND and WEATHERED BEDROCK, trace cobble; moist.		0.0	
10	10' of 2-inch diameter, 0.020" slotted screen.	Grey, BEDROCK; wet.			Bedrock encountered at 9 ft bls.
15	Bottom of well.				End of boring 15 ft bls.

BORING/FEET 2611.0002Y002.GPJ ROUX.GDT 7/3/18



ROUX ASSOCIATES, INC.  
Environmental Consulting  
& Management

209 Shafter Street  
Islandia, NY 11749  
Telephone: (631) 232-2600  
Fax: (631) 232-9898

# WELL CONSTRUCTION LOG

WELL NO. <b>RXMW-2</b>	NORTHING <b>235940.279</b>	EASTING <b>1014390.293</b>
PROJECT NO./NAME <b>2611.0002Y002 / Spofford Avenue</b>		LOCATION <b>1221 Spofford Avenue</b>
APPROVED BY <b>J. Wills</b>	LOGGED BY <b>Rachel Miller</b>	<b>Bronx, New York</b>
DRILLING CONTRACTOR/DRILLER <b>Aquifer Drilling and Testing / German H.</b>		GEOGRAPHIC AREA <b>Tiffany Street Sidewalk</b>
DRILL BIT DIAMETER/TYPE <b>4" / Drive Sampler</b>	BOREHOLE DIAMETER <b>4-inches</b>	DRILLING EQUIPMENT/METHOD <b>8140LC / Rotosonic</b>
CASING MAT./DIA. <b>PVC / 2-inch</b>	SCREEN: <b>TYPE Slotted</b>	SAMPLING METHOD <b>Sonic Core</b>
ELEVATION OF: (Feet)	GROUND SURFACE <b>32.09</b>	TOP OF WELL CASING <b>/</b>
		TOP & BOTTOM SCREEN <b>/</b>
		GRAVEL PACK SIZES <b>Morie #2</b>
		MAT. <b>PVC</b>
		TOTAL LENGTH <b>10.0ft</b>
		DIA. <b>2-inch</b>
		SLOT SIZE <b>20-slot</b>

Depth, feet	Graphic Log	Visual Description	Blow Counts per 6"	PID Values (ppm)	REMARKS
0	Concrete.	CONCRETE.		0.0	Hand cleared to 5 ft bls.
0	Grout.	Dark brown, medium to coarse SAND, some fine Sand, little Silt, trace gravel; dry.		0.0	Sample RXMW-2_0-2 collected for TCL VOCs, TCL SVOCs, Pesticides, Herbicides, TAL Metals, Hex Chromium, PCBs, and Total Cyanide.
5	Bentonite pellets.	Light brown, medium to coarse SAND and SILT, some fine Sand, little Gravel, trace Clay; dry.		0.0	
10	Morie #2 sand.	Light brown, medium to coarse SAND and SILT, some fine Sand, little Gravel, trace Clay; moist.		0.0	
15	10' of 2-inch diameter, 0.020" slotted screen.	Light grey, medium to coarse SAND and WEATHERED BEDROCK, little cobbles; moist.		0.2	Sample RXMW-2_13-15 collected for TCL VOCs, TCL SVOCs, Pesticides, Herbicides, TAL Metals, Hex Chromium, PCBs, and Total Cyanide.
15		Grey, BEDROCK; wet.			Bedrock encountered at 15 ft bls.
20	Bottom of well.				End of boring 20 ft bls.

BORING/FEET 2611.0002Y002.GPJ ROUX.GDT 7/3/18



ROUX ASSOCIATES, INC.  
Environmental Consulting  
& Management

209 Shafter Street  
Islandia, NY 11749  
Telephone: (631) 232-2600  
Fax: (631) 232-9898

Page 1 of 1

## WELL CONSTRUCTION LOG

WELL NO. <b>RXMW-3</b>	NORTHING <b>236050.062</b>	EASTING <b>1014667.432</b>	
PROJECT NO./NAME <b>2611.0002Y002 / Spofford Avenue</b>		LOCATION <b>1221 Spofford Avenue</b>	
APPROVED BY <b>J. Wills</b>	LOGGED BY <b>Rachel Miller</b>	<b>Bronx, New York</b>	
DRILLING CONTRACTOR/DRILLER <b>Aquifer Drilling and Testing / Rob G.</b>		GEOGRAPHIC AREA <b>Former Boiler Room Basement (Wing F)</b>	
DRILL BIT DIAMETER/TYPE <b>2" / Drive Sampler</b>	BOREHOLE DIAMETER <b>3-inches</b>	DRILLING EQUIPMENT/METHOD <b>420 / Geoprobe</b>	SAMPLING METHOD <b>2" Macro-Core</b>
CASING MAT./DIA. <b>PVC / 2-inch</b>	SCREEN: <b>TYPE Slotted</b>	MAT. <b>PVC</b>	TOTAL LENGTH <b>7.0</b> ft
ELEVATION OF: (Feet)	GROUND SURFACE <b>29.48</b>	TOP OF WELL CASING <b>/</b>	TOP & BOTTOM SCREEN <b>/</b>
		DIA. <b>2-inch</b>	
		SLOT SIZE <b>20-Slot</b>	
		GRAVEL PACK SIZES <b>Morie #2</b>	

Depth, feet	Graphic Log	Visual Description	Blow Counts per 6"	PID Values (ppm)	REMARKS
1		CONCRETE.			Sample RXMW-3 1-3 collected for TCL VOCs, TCL SVOCs, Pesticides, Herbicides, TAL Metals, Hex Chromium, PCBs, and Total Cyanide.
2		Dark brown to dark grey, fine SAND and SILT, some coarse Sand, little Gravel; wet.	1.9		Odor and staining observed in soil at approximately 1.5 ft bls.
3		Grey, BEDROCK; wet.			Bedrock encountered at 3 ft bls.
4					
5					
6					
7					
8					End of boring at 8 ft bls.

BORING/FEET 2611.0002Y002.GPJ ROUX.GDT 7/3/18





ROUX ASSOCIATES, INC.  
Environmental Consulting  
& Management

209 Shafter Street  
Islandia, NY 11749  
Telephone: (631) 232-2600  
Fax: (631) 232-9898

# WELL CONSTRUCTION LOG

WELL NO. <b>RXMW-4</b>	NORTHING <b>236005.467</b>	EASTING <b>1014676.725</b>
PROJECT NO./NAME <b>2611.0002Y002 / Spofford Avenue</b>		LOCATION <b>1221 Spofford Avenue</b>
APPROVED BY <b>J. Wills</b>	LOGGED BY <b>Ron Lombino</b>	<b>Bronx, New York</b>
DRILLING CONTRACTOR/DRILLER <b>Aquifer Drilling and Testing / Tony P.</b>		GEOGRAPHIC AREA <b>Southeast Courtyard</b>
DRILL BIT DIAMETER/TYPE <b>4" / Drive Sampler</b>	BOREHOLE DIAMETER <b>4-inches</b>	DRILLING EQUIPMENT/METHOD <b>8140LC / Rotosonic</b>
CASING MAT./DIA. <b>PVC / 2-inch</b>	SCREEN: <b>TYPE Slotted</b>	MAT. <b>PVC</b>
TOTAL LENGTH <b>8.0</b> ft		DIA. <b>2-inch</b>
ELEVATION OF: GROUND SURFACE (Feet) <b>50.48</b>		TOP & BOTTOM SCREEN <b>/</b>
GRAVEL PACK SIZES <b>Morie #2</b>		SAMPLING METHOD <b>Sonic Core</b>
START-FINISH DATE <b>4/24/18-5/1/18</b>		SLOT SIZE <b>20-slot</b>

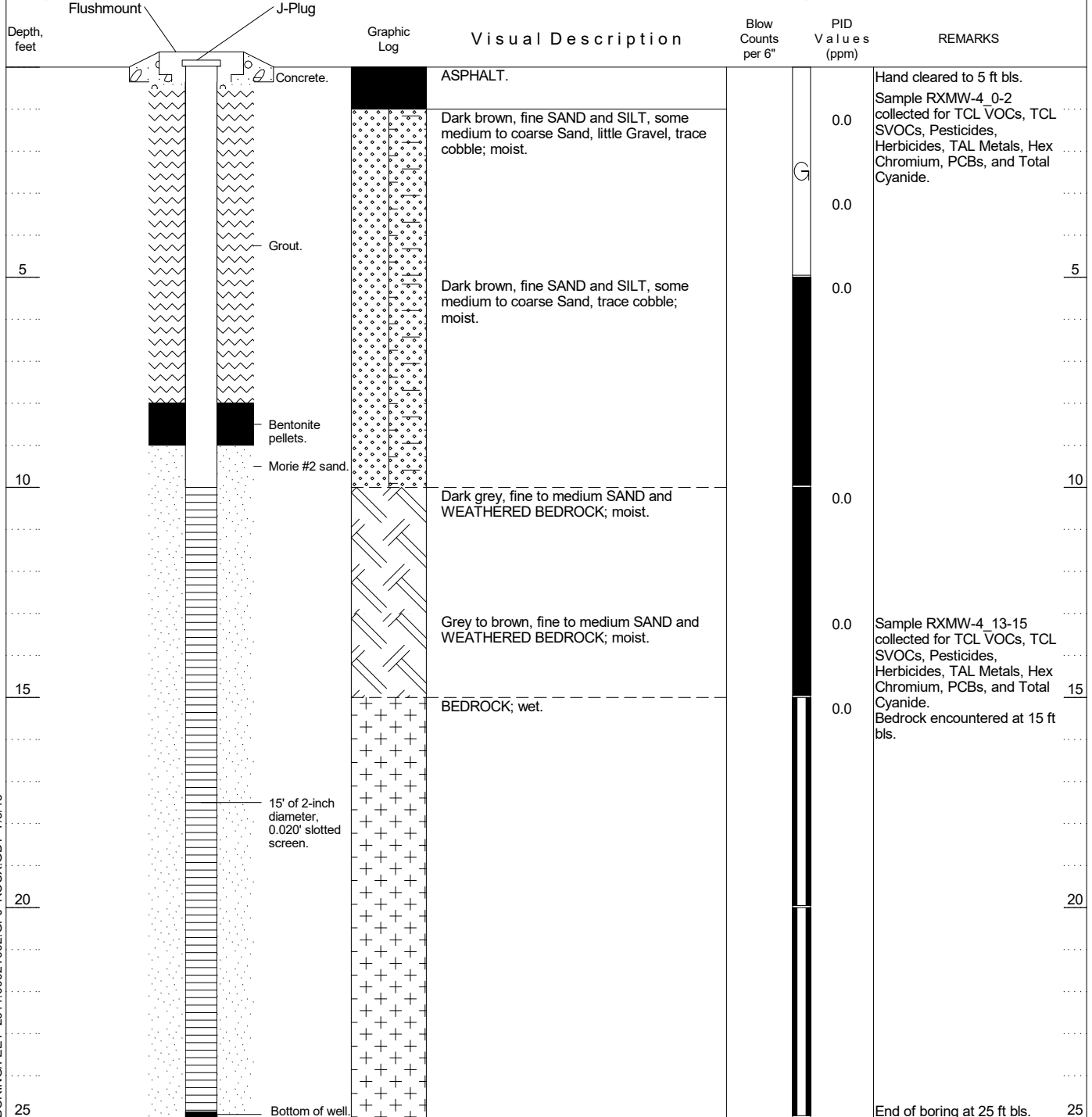



ROUX ASSOCIATES, INC.  
Environmental Consulting  
& Management

209 Shafter Street  
Islandia, NY 11749  
Telephone: (631) 232-2600  
Fax: (631) 232-9898

# WELL CONSTRUCTION LOG

WELL NO. <b>RXMW-5</b>	NORTHING <b>235954.481</b>	EASTING <b>1014711.047</b>
PROJECT NO./NAME <b>2611.0002Y002 / Spofford Avenue</b>		LOCATION <b>1221 Spofford Avenue</b>
APPROVED BY <b>J. Wills</b>	LOGGED BY <b>L. Sugano</b>	<b>Bronx, New York</b>
DRILLING CONTRACTOR/DRILLER <b>Aquifer Drilling and Testing / Tony P.</b>		GEOGRAPHIC AREA <b>Southeast Courtyard</b>
DRILL BIT DIAMETER/TYPE <b>4" / Drive Sampler</b>	BOREHOLE DIAMETER <b>4-inches</b>	DRILLING EQUIPMENT/METHOD <b>8140LC / Rotosonic</b>
CASING MAT./DIA. <b>PVC / 2-inch</b>	SCREEN: <b>TYPE Slotted</b>	MAT. <b>PVC</b>
ELEVATION OF: (Feet)		TOTAL LENGTH <b>10.0ft</b>
GROUND SURFACE	TOP OF WELL CASING <b>50.37</b>	TOP & BOTTOM SCREEN <b>/</b>
GRAVEL PACK SIZES <b>Morie #2</b>		DIA. <b>2-inch</b> SLOT SIZE <b>20-slot</b>

Depth, feet	Graphic Log	Visual Description	Blow Counts per 6"	PID Values (ppm)	REMARKS
0	Flushmount, J-Plug, Concrete.	ASPHALT.		0.0	Hand cleared to 5 ft bls.
0		Grey, medium to coarse SAND and GRAVEL, some fine Sand and Silt, trace cobble (fill); moist.		0.0	Sample RXMW-5_0-2 collected for TCL VOCs, TCL SVOCs, Pesticides, Herbicides, TAL Metals, Hex Chromium, PCBs, and Total Cyanide.
0		Dark brown, fine SAND and SILT, some Gravel, little Cobble and Brick, trace medium to coarse Sand (fill); moist.		0.0	
5	Grout.	Dark brown, fine SAND and SILT, some medium to coarse Sand, trace gravel and brick (fill); moist.		0.0	
10	Bentonite pellets, Morie #2 sand	Brown, fine to medium SAND and WEATHERED BEDROCK; moist.		0.0	
15	10' of 2-inch diameter, 0.020" slotted screen.	Grey, BEDROCK; wet.		0.0	Bedrock encountered at 14 ft bls.
20	Bottom of well.				End of boring at 20 ft bls.

BORING/FEET 2611.0002Y002.GPJ ROUX.GDT 7/3/18



ROUX ASSOCIATES, INC.  
Environmental Consulting  
& Management

209 Shafter Street  
Islandia, NY 11749  
Telephone: (631) 232-2600  
Fax: (631) 232-9898

# WELL CONSTRUCTION LOG

WELL NO. <b>RXMW-6</b>	NORTHING <b>235938.248</b>	EASTING <b>1014802.507</b>
PROJECT NO./NAME <b>2611.0002Y002 / Spofford Avenue</b>		LOCATION <b>1221 Spofford Avenue</b>
APPROVED BY <b>J. Wills</b>	LOGGED BY <b>L. Sugano</b>	<b>Bronx, New York</b>
DRILLING CONTRACTOR/DRILLER <b>Aquifer Drilling and Testing / Tony P.</b>		GEOGRAPHIC AREA <b>Southeast Courtyard</b>
DRILL BIT DIAMETER/TYPE <b>4" / Drive Sampler</b>	BOREHOLE DIAMETER <b>4-inches</b>	DRILLING EQUIPMENT/METHOD <b>8140LC / Rotosonic</b>
CASING MAT./DIA. <b>PVC / 2-inch</b>	SCREEN: <b>TYPE Slotted</b>	MAT. <b>PVC</b>
TOTAL LENGTH <b>10.0ft</b>		DIA. <b>2-inch</b>
ELEVATION OF: GROUND SURFACE (Feet) <b>50.52</b>		TOP & BOTTOM SCREEN <b>/</b>
GRAVEL PACK SIZES <b>Morie #2</b>		SLOT SIZE <b>20-slot</b>

Depth, feet	Graphic Log	Visual Description	Blow Counts per 6"	PID Values (ppm)	REMARKS
0		ASPHALT.			Hand cleared to 5 ft bls.
0.0		Dark brown, fine SAND and SILT, some medium to coarse Sand, little Brick, trace wood and cobble (fill); wet.			Sample RXMW-6_0-2 collected for TCL VOCs, TCL SVOCs, Pesticides, Herbicides, TAL Metals, Hex Chromium, PCBs, and Total Cyanide. Perched water observed at approximately 1 ft bls.
0.0		Brown, fine SAND and SILT, some Gravel, trace cobble (fill); wet.			
5		Brown to grey, fine SAND and SILT, some medium to coarse Sand, little Gravel, trace brick (fill); moist.			
0.0		Brown, fine to medium SAND and WEATHERED BEDROCK; moist.			
10		Grey, fine to medium SAND and WEATHERED BEDROCK; moist.			Sample RXMW-6_9-11 collected for TCL VOCs, TCL SVOCs, Pesticides, Herbicides, TAL Metals, Hex Chromium, PCBs, and Total Cyanide.
10		Grey, BEDROCK; wet.			Bedrock encountered at 11 ft bls.
15					End of boring at 16 ft bls.

BORING/FEET 2611.0002Y002.GPJ ROUX.GDT 7/3/18



ROUX ASSOCIATES, INC.  
Environmental Consulting  
& Management

209 Shafter Street  
Islandia, NY 11749  
Telephone: (631) 232-2600  
Fax: (631) 232-9898

# WELL CONSTRUCTION LOG

WELL NO. <b>RXMW-7</b>	NORTHING <b>236006.039</b>	EASTING <b>1014809.493</b>
PROJECT NO./NAME <b>2611.0002Y002 / Spofford Avenue</b>		LOCATION <b>1221 Spofford Avenue</b>
APPROVED BY <b>J. Wills</b>	LOGGED BY <b>Rachel Miller</b>	<b>Bronx, New York</b>
DRILLING CONTRACTOR/DRILLER <b>Aquifer Drilling and Testing / German H.</b>		GEOGRAPHIC AREA <b>Southeast Courtyard</b>
DRILL BIT DIAMETER/TYPE <b>4" / Drive Sampler</b>	BOREHOLE DIAMETER <b>4-inches</b>	DRILLING EQUIPMENT/METHOD <b>8140LC / Rotosonic</b>
CASING MAT./DIA. <b>PVC / 2-inch</b>	SCREEN: <b>TYPE Slotted</b>	MAT. <b>PVC</b>
TOTAL LENGTH <b>10.0ft</b>		DIA. <b>2-inch</b>
ELEVATION OF: GROUND SURFACE		START-FINISH DATE <b>6/14/18-6/15/18</b>
(Feet)	TOP OF WELL CASING <b>50.71</b>	TOP & BOTTOM SCREEN <b>/</b>
GRAVEL PACK SIZES <b>Morie #2</b>		

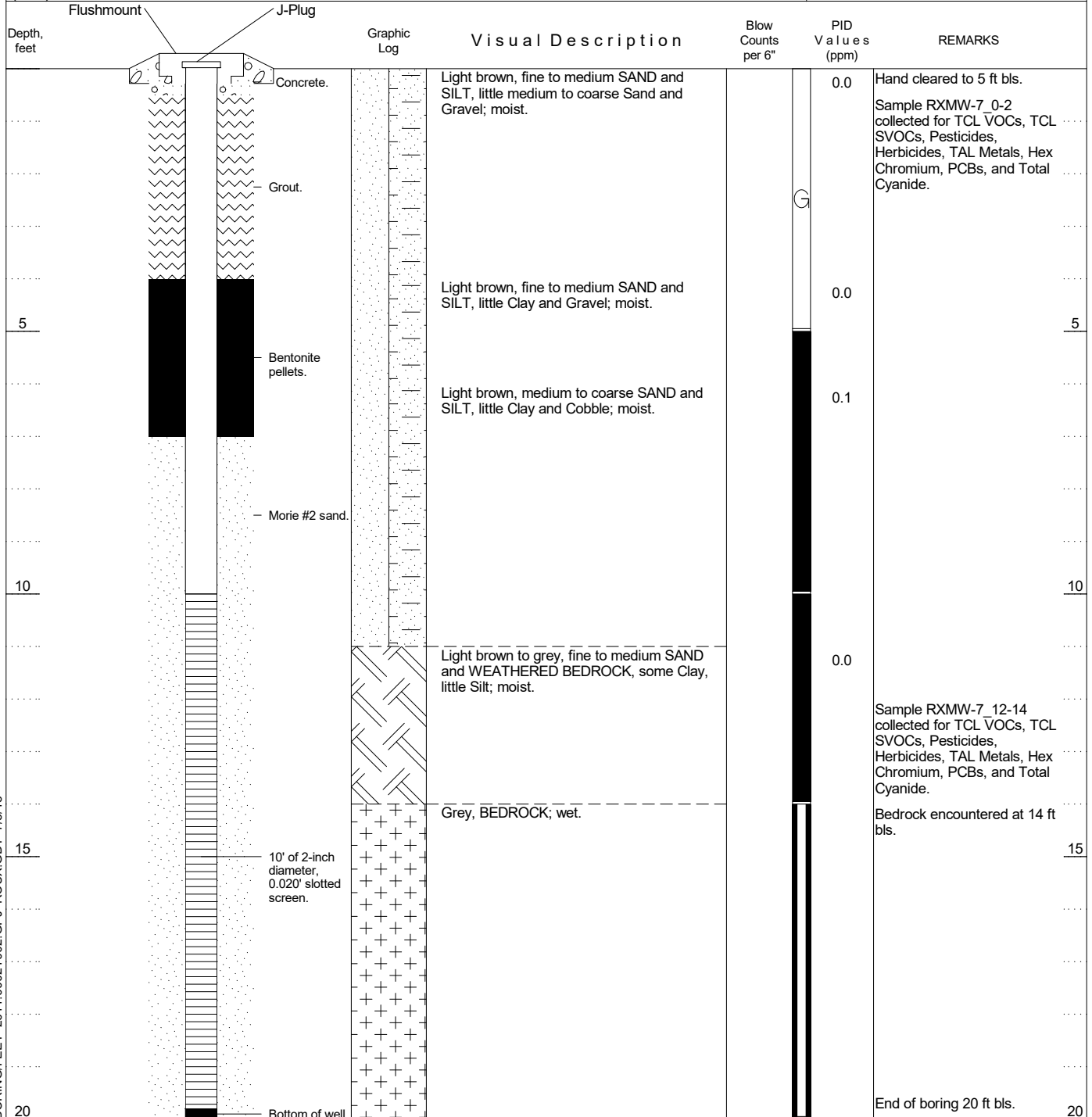

BORING/FEET 2611.0002Y002.GPJ ROUX.GDT 7/9/18



ROUX ASSOCIATES, INC.  
Environmental Consulting  
& Management

209 Shafter Street  
Islandia, NY 11749  
Telephone: (631) 232-2600  
Fax: (631) 232-9898

# WELL CONSTRUCTION LOG

WELL NO. <b>RXMW-8</b>	NORTHING <b>236049.926</b>	EASTING <b>1014756.752</b>
PROJECT NO./NAME <b>2611.0002Y002 / Spofford Avenue</b>		LOCATION <b>1221 Spofford Avenue</b>
APPROVED BY <b>J. Wills</b>	LOGGED BY <b>Rachel Miller</b>	<b>Bronx, New York</b>
DRILLING CONTRACTOR/DRILLER <b>Aquifer Drilling and Testing / Rob G.</b>		GEOGRAPHIC AREA <b>Former Laundry Room (Wing F)</b>
DRILL BIT DIAMETER/TYPE <b>2" / Drive Sampler</b>	BOREHOLE DIAMETER <b>3-inches</b>	DRILLING EQUIPMENT/METHOD <b>420 / Geoprobe</b>
CASING MAT./DIA. <b>PVC / 2-inch</b>	SCREEN: <b>TYPE Slotted</b>	MAT. <b>PVC</b>
TOTAL LENGTH <b>8.0</b> ft		DIA. <b>2-inch</b>
SLOT SIZE <b>20-slot</b>		
ELEVATION OF: (Feet)	GROUND SURFACE <b>44.01</b>	TOP OF WELL CASING <b>/</b>
TOP & BOTTOM SCREEN <b>/</b>		GRAVEL PACK SIZES <b>Morie #2</b>

Depth, feet	Flushmount	J-Plug	Graphic Log	Visual Description	Blow Counts per 6"	PID Values (ppm)	REMARKS
			Concrete.	CONCRETE.			
				Dark brown, fine SAND and SILT, some medium to coarse Sand, little Gravel; dry.		0.1	Sample RXMW-8_1-3 collected for TCL VOCs, TCL SVOCs, Pesticides, Herbicides, TAL Metals, Hex Chromium, PCBs, and Total Cyanide.
5			Grout.				
			Bentonite pellets.			0.1	
			Morie #2 sand.	Light brown, fine SAND and SILT, some medium to coarse Sand; moist.			
10				Grey, medium to coarse SAND, some Gravel, little fine Sand; wet.		1.7	Sample RXMW-8_9-11 collected for TCL VOCs, TCL SVOCs, Pesticides, Herbicides, TAL Metals, Hex Chromium, PCBs, and Total Cyanide.
				Grey, BEDROCK; wet.			Bedrock encountered at 11 ft bls.
15			8' of 2-inch diameter, 0.020' slotted screen.				
			Bottom of well.				End of boring 17 ft bls.

BORING/FEET 2611.0002Y002.GPJ ROUX.GDT 7/3/18



ROUX ASSOCIATES, INC.  
Environmental Consulting  
& Management

209 Shafter Street  
Islandia, NY 11749  
Telephone: (631) 232-2600  
Fax: (631) 232-9898

# WELL CONSTRUCTION LOG

WELL NO. <b>RXMW-9</b>	NORTHING <b>236110.801</b>	EASTING <b>1014579.727</b>
PROJECT NO./NAME <b>2611.0002Y002 / Spofford Avenue</b>		LOCATION <b>1221 Spofford Avenue</b>
APPROVED BY <b>J. Wills</b>	LOGGED BY <b>Ron Lombino</b>	<b>Bronx, New York</b>
DRILLING CONTRACTOR/DRILLER <b>Aquifer Drilling and Testing / Tony P.</b>		GEOGRAPHIC AREA <b>Northwest Courtyard</b>
DRILL BIT DIAMETER/TYPE <b>4" / Drive Sampler</b>	BOREHOLE DIAMETER <b>4-inches</b>	DRILLING EQUIPMENT/METHOD <b>8140LC / Rotosonic</b>
CASING MAT./DIA. <b>PVC / 2-inch</b>	SCREEN: <b>TYPE Slotted</b>	SAMPLING METHOD <b>Sonic Core</b>
ELEVATION OF: (Feet)		START-FINISH DATE <b>4/23/18-4/25/18</b>
GROUND SURFACE	TOP OF WELL CASING <b>58.21</b>	TOTAL LENGTH <b>8.0</b> ft
		DIA. <b>2-inch</b>
		SLOT SIZE <b>20-slot</b>
		GRAVEL PACK SIZES <b>Morie #2</b>

Depth, feet	Graphic Log	Visual Description	Blow Counts per 6"	PID Values (ppm)	REMARKS
0	Flushmount Concrete. J-Plug Grout.	ASPHALT.			Hand cleared to 5 ft bls.
1		Dark to light grey, fine to coarse SAND, some Gravel, little Silt; moist.			Sample RXMW-9_0-2 collected for TCL VOCs, TCL SVOCs, Pesticides, Herbicides, TAL Metals, Hex Chromium, PCBs, and Total Cyanide. ...1
2	Bentonite pellets.	Dark brown, fine SAND and SILT, some medium to coarse Sand and Gravel, little Cobble; moist.		0.0	...2
3					...3
4	Morie #2 sand.			0.0	...4
5					...5
6				0.0	Sample RXMW-9_5-7 collected for TCL VOCs, TCL SVOCs, Pesticides, Herbicides, TAL Metals, Hex Chromium, PCBs, and Total Cyanide. ...6
7		Grey, fine to medium SAND and WEATHERED BEDROCK; moist.			...7
8	8' of 2-inch diameter, 0.020" slotted screen.	Grey, BEDROCK; wet.		0.0	Bedrock encountered at 7.5 ft bls. ...8
9					...9
10					...10
11					...11
12	Bottom of well.				End of boring at 12 ft bls. ...12

BORING/FEET 2611.0002Y002.GPJ ROUX.GDT 7/8/18



ROUX ASSOCIATES, INC.  
Environmental Consulting  
& Management

209 Shafter Street  
Islandia, NY 11749  
Telephone: (631) 232-2600  
Fax: (631) 232-9898

# WELL CONSTRUCTION LOG

WELL NO. <b>RXMW-10</b>	NORTHING <b>236169.224</b>	EASTING <b>1014436.137</b>
PROJECT NO./NAME <b>2611.0002Y002 / Spofford Avenue</b>		LOCATION <b>1221 Spofford Avenue</b>
APPROVED BY <b>J. Wills</b>	LOGGED BY <b>Ron Lombino</b>	<b>Bronx, New York</b>
DRILLING CONTRACTOR/DRILLER <b>Aquifer Drilling and Testing / Tony P.</b>		GEOGRAPHIC AREA <b>Northwest Courtyard</b>
DRILL BIT DIAMETER/TYPE <b>4" / Drive Sampler</b>	BOREHOLE DIAMETER <b>4-inches</b>	DRILLING EQUIPMENT/METHOD <b>8140LC / Rotosonic</b>
CASING MAT./DIA. <b>PVC / 2-inch</b>	SCREEN: <b>TYPE Slotted</b>	MAT. <b>PVC</b>
ELEVATION OF: (Feet)		TOTAL LENGTH <b>8.0</b> ft
GROUND SURFACE	TOP OF WELL CASING <b>58.48</b>	TOP & BOTTOM SCREEN <b>/</b>
GRAVEL PACK SIZES <b>Morie #2</b>		DIA. <b>2-inch</b> SLOT SIZE <b>20-slot</b>

Depth, feet	Graphic Log	Visual Description	Blow Counts per 6"	PID Values (ppm)	REMARKS
0	Flushmount J-Plug Concrete.	ASPHALT.		0.0	Hand cleared to 5 ft bls.
1	Bentonite pellets. Morie #2 sand.	CONCRETE. Dark brown, fine SAND and SILT, some Gravel, little medium to coarse Sand, trace brick (fill); moist.		0.0	Sample RXMW-10_0-2 collected for TCL VOCs, TCL SVOCs, Pesticides, Herbicides, TAL Metals, Hex Chromium, PCBs, and Total Cyanide.
2				0.0	Sample RXMW-10_2-4 collected for TCL VOCs, TCL SVOCs, Pesticides, Herbicides, TAL Metals, Hex Chromium, PCBs, and Total Cyanide.
3		Dark brown, fine SAND and SILT, some Gravel, little medium to coarse Sand, trace cobble; moist.		0.0	
4					Bedrock encountered at 5 ft bls.
5		Grey, BEDROCK, wet.		0.0	
6	8' of 2-inch diameter, 0.020' slotted screen.				
7					
8					
9					
10	Bottom of well.				End of boring 10 ft bls.

BORING/FEET 2611.0002Y002.GPJ ROUX.GDT 7/9/18



ROUX ASSOCIATES, INC.  
Environmental Consulting  
& Management

209 Shafter Street  
Islandia, NY 11749  
Telephone: (631) 232-2600  
Fax: (631) 232-9898

# WELL CONSTRUCTION LOG

WELL NO. <b>RXMW-11</b>	NORTHING <b>235951.167</b>	EASTING <b>1014554.65</b>
PROJECT NO./NAME <b>2611.0002Y002 / Spofford Avenue</b>		LOCATION <b>1221 Spofford Avenue</b>
APPROVED BY <b>J. Wills</b>	LOGGED BY <b>Ron Lombino</b>	<b>Bronx, New York</b>
DRILLING CONTRACTOR/DRILLER <b>Aquifer Drilling and Testing / Tony P.</b>		GEOGRAPHIC AREA <b>Southwest Courtyard</b>
DRILL BIT DIAMETER/TYPE <b>4" / Drive Sampler</b>	BOREHOLE DIAMETER <b>4-inches</b>	DRILLING EQUIPMENT/METHOD <b>8140LC / Rotosonic</b>
CASING MAT./DIA. <b>PVC / 2-inch</b>	SCREEN: <b>TYPE Slotted</b>	MAT. <b>PVC</b>
ELEVATION OF: (Feet)		TOTAL LENGTH <b>12.0ft</b>
GROUND SURFACE	TOP OF WELL CASING <b>34.33</b>	TOP & BOTTOM SCREEN <b>/</b>
GRAVEL PACK SIZES <b>Morie #2</b>		DIA. <b>2-inch</b>
SLOT SIZE <b>20-slot</b>		

Depth, feet	Graphic Log	Visual Description	Blow Counts per 6"	PID Values (ppm)	REMARKS
0	Flushmount Concrete.	ASPHALT.			Hand cleared to 5 ft bls.
0	Grout.	Light grey, fine to coarse SAND, some Gravel, little Silt and Cobble; dry.		0.0	Sample RXMW-11_0-2 collected for TCL VOCs, TCL SVOCs, Pesticides, Herbicides, TAL Metals, Hex Chromium, PCBs, and Total Cyanide.
5	Bentonite pellets.	Dark grey to reddish brown, fine to medium SAND and WEATHERED BEDROCK; moist.		0.0	
5	Morie #2 sand.	Light to dark grey, fine to medium SAND and WEATHERED BEDROCK; moist.		0.0	
10	12' of 2-inch diameter, 0.020" slotted screen.			0.0	Sample RXMW-11_11-13 collected for TCL VOCs, TCL SVOCs, Pesticides, Herbicides, TAL Metals, Hex Chromium, PCBs, and Total Cyanide.
15		Grey, BEDROCK; wet.		0.0	Bedrock encountered at 15 ft bls.
20	Bottom of well.				End of boring at 20 ft bls.

BORING/FEET 2611.0002Y002.GPJ ROUX.GDT 7/9/18





Client: The Peninsula JV LLC		Site: The Peninsula		Project Number: 2611.0002Y000	
Address: 1221 Spofford Avenue		City/State: Bronx, NY		Logged By: P. Kilkelly	
Start to Finish Date: 7/8/2020 - 7/8/2020	Contractor: Aquifer Drilling and Testing		Drill Type: Geoprobe	Sampler Type/Method: Air Hammer	
Borehole Depth: 10 feet	Backfill: N/A		Borehole Diameter: 3-inches	DTW: 3.19	
Area: Building 2B	Elevation: NM		Northing: NM	Easting: NM	
Well Depth: 10 feet	Well Dia./Materials: 2-inch PVC	Screen Interval: 3 ft als - 10 ft bls	Screen Slot Size: 20-Slot	Sand/Filter Pack Size: #2	Annular Seal: N/A

Depth (ft)	Well Diagram	USCS	USCS Graphic	Visual Description	Sample Interval	Recovery (ft)	PID	Notes
	<p>2" J Plug Standpipe 2" SCH-40 PVC Riser 20-slot SCH-40 PVC screen #2 Sand Bottom Plug</p>			Grey, WEATHERED BEDROCK; wet.				
5				Grey, BEDROCK; wet.				
								BRMW-1 air hammered into bedrock to 10 ft bls.

ROUX STANDARD LOG - 7/30/20 20.06 - S:\GINT\PROJECTS\2611.0002Y000\_PHASE2 - SUPPLEMENTAL WC RESTORED.GPJ

Bottom of borehole at 10 feet



Client: The Peninsula JV LLC		Site: The Peninsula		Project Number: 2611.0002Y000	
Address: 1221 Spofford Avenue		City/State: Bronx, NY		Logged By: P. Kilkelly	
Start to Finish Date: 7/8/2020 - 7/8/2020	Contractor: Aquifer Drilling and Testing		Drill Type: Geoprobe	Sampler Type/Method: Air Hammer	
Borehole Depth: 12 feet	Backfill: N/A		Borehole Diameter: 3-inches	DTW: 2.31	
Area: Building 2B	Elevation: NM		Northing: NM	Easting: NM	
Well Depth: 12 feet	Well Dia./Materials: 2-inch PVC	Screen Interval: 1 ft als - 12 ft bls	Screen Slot Size: 20-Slot	Sand/Filter Pack Size: #2	Annular Seal: N/A

Depth (ft)	Well Diagram	USCS	USCS Graphic	Visual Description	Sample Interval	Recovery (ft)	PID	Notes
	<p>2" J Plug Standpipe 2" SCH-40 PVC Riser #2 Sand 20-slot SCH-40 PVC screen Bottom Plug</p>			Grey, BEDROCK; wet.				
5								
10								
12								BRMW-2 air hammered into bedrock to 12 ft bls.

ROUX STANDARD LOG - 7/30/20 20.06 - S:\GINT\PROJECTS\2611.0002Y000\_PHASE2 - SUPPLEMENTAL WC RESTORED.GPJ

Bottom of borehole at 12 feet

Track 2 Determination Letter

# NEW YORK STATE DEPARTMENT OF ENVIRONMENTAL CONSERVATION

Division of Environmental Remediation, Region 2  
47-40 21st Street, Long Island City, NY 11101  
P: (718) 482-4995  
www.dec.ny.gov

September 15, 2020

Ed Broderick  
The Peninsula JV, LLC  
7 Jackson Walkway  
Providence, RI 02903

**Re: The Peninsula, Bronx County  
1221 Spofford Avenue, Bronx  
Brownfield Cleanup Program # C203097  
Track 2 Determination**

Dear Mr. Broderick:

The New York State Department of Environmental Conservation (the Department) has reviewed the endpoint soil sample results which were submitted by Roux Environmental Engineering and Geology, D.P.C. The data was compared against the restricted residential soil cleanup objectives (RRSCOs), as identified by the Decision Document dated December 2018. Of the 111 endpoint samples collected, 9 have minor exceedances of the RRSCOs. In accordance with DER-10 5.4(b)(2)(i) the Department has determined that excavation has achieved the Track 2 remedial action objectives.

Should you have any questions regarding this letter or any other aspect of the project, please contact me at 718-482-7541 or wendi.zheng@dec.ny.gov.

Regards,

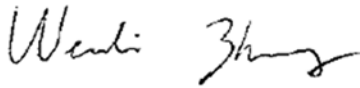

Wendi Zheng  
Project Manager

cc: G. Burke, J. O'Connell, S. Martinkat, A. Levine – NYSDEC  
S. McLaughlin, M. Doroski – NYSDOH  
I. Speliotis – MHANY Peninsula Local Development Corp., Spofford 1B Housing Development Fund Corp.  
A. Koffman – Peninsula Building 1B LLC  
F. Cherena, L. Dolginko – Roux  
L. Schnapf – Schnapf LLC

Excavation Work Plan



# Excavation Work Plan

---

1221 Spofford Avenue  
Bronx, New York

October 30, 2020

Prepared for:

**The Peninsula JV, LLC**  
7 Jackson Walkway  
Providence, Rhode Island 02903

Prepared by:

**Roux Environmental Engineering  
and Geology, D.P.C.**  
209 Shafter Street  
Islandia, New York 11749

## APPENDIX C – EXCAVATION WORK PLAN (EWP)

### C-1 NOTIFICATION

At least 15 days prior to the start of any activity that is anticipated to encounter remaining contamination, the Site owner or their representative will notify the NYSDEC. Table 1 includes contact information for the above notification. The information on this table will be updated as necessary to provide accurate contact information. A full listing of Site-related contact information is provided in Appendix B.

**Table 1: Notifications\***

NYSDEC Project Manager: Wendi Zheng	718-482-8541 <a href="mailto:wendi.zheng@dec.ny.gov">wendi.zheng@dec.ny.gov</a>
NYSDEC Regional HW Remediation Engineer: Jane O’Connell	718-482-4599 <a href="mailto:jane.oconnell@dec.ny.gov">jane.oconnell@dec.ny.gov</a>
NYSDEC, Site Control: Kelly Lewandowski	Chief, Site Control Section New York State Department of Environmental Conservation Division of Environmental Remediation 625 Broadway Albany NY 12233-7020  518-402-9543  <a href="mailto:kelly.lewandowski@dec.ny.gov">kelly.lewandowski@dec.ny.gov</a>

\* Note: Notifications are subject to change and will be updated as necessary.

This notification will include:

- A detailed description of the work to be performed, including the location and areal extent of excavation, plans/drawings for site re-grading, intrusive elements or utilities and estimated volumes of contaminated soil to be excavated;

- A summary of environmental conditions anticipated to be encountered in the work areas, including the nature and concentration levels of contaminants of concern, potential presence of grossly contaminated media, and plans for any pre-construction sampling;
- A schedule for the work, detailing the start and completion of all intrusive work;
- A summary of the applicable components of this EWP;
- A statement that the work will be performed in compliance with this EWP and 29 CFR 1910.120;
- A copy of the contractor's health and safety plan (HASP), in electronic format, if it differs from the HASP provided in Appendix H of this SMP;
- Identification of disposal facilities for potential waste streams; and
- Identification of sources of any anticipated backfill, along with all required chemical testing results.

## **C-2 SOIL SCREENING METHODS**

Since the Site was received a Track 2 Restricted Residential Soil Cleanup Objectives (SCOs) by way of endpoint sampling, visual, olfactory, and instrument-based (e.g. photoionization detector [PID]) soil screening will only be performed during soil characterization and loadout, unless unexpected conditions are encountered in the form of including grossly contaminated soil or groundwater. In the event that the screening is required, visual, olfactory, and instrument based (e.g. PID) soil screening will be completed by a qualified environmental professional.

Soils will be segregated based on previous environmental data and screening results into material that requires offsite disposal and material that requires testing to determine if the material can be reused onsite. Further discussion of offsite disposal of materials and onsite reuse is provided in Sections C-6 and C-7 of this EWP.



### **C-3 SOIL STAGING METHODS**

Soil stockpiles will be continuously encircled with a berm and/or silt fence. Hay bales will be used as needed near catch basins, surface waters and other discharge points.

Stockpiles will be kept covered at all times with appropriately anchored tarps. Stockpiles will be routinely inspected and damaged tarp covers will be promptly replaced.

Stockpiles will be inspected at a minimum once each week and after every storm event. Results of inspections will be recorded in a logbook and maintained at the site and available for inspection by the NYSDEC.

### **C-4 MATERIALS EXCAVATION AND LOAD-OUT**

A qualified environmental professional or person under their supervision will oversee the load-out of all excavated material. The owner of the property and remedial party (if applicable) and its contractors are responsible for safe execution of all invasive and other work performed under this EWP.

The presence of utilities and easements on the Site will be investigated by the qualified environmental professional. It will be determined whether a risk or impediment to the planned work under this SMP is posed by utilities or easements on the Site.

Loaded vehicles leaving the Site will be appropriately lined, tarped, securely covered, manifested, and placarded in accordance with appropriate Federal, State, local, and New York State Department of Transportation (NYSDOT) requirements (and all other applicable transportation requirements).

A truck wash will be operated onsite, as appropriate. The qualified environmental professional will be responsible for ensuring that all outbound trucks will be washed at the truck wash before leaving the Site until the activities performed under this section are complete.

Locations where vehicles enter or exit the Site shall be inspected daily for evidence of offsite soil tracking.

The qualified environmental professional will be responsible for ensuring that all egress points for truck and equipment transport from the Site are clean of dirt and other materials derived from the Site during intrusive excavation activities. Cleaning of the adjacent streets will be performed as needed to maintain a clean condition with respect to Site-derived materials.

### **C-5 MATERIALS TRANSPORT OFFSITE**

All transport of materials will be performed by licensed haulers in accordance with appropriate local, State, and Federal regulations, including 6 NYCRR Part 364. Haulers will be appropriately licensed and trucks properly placarded.

Material transported by trucks exiting the Site will be secured with tight-fitting covers. Loose-fitting canvas-type truck covers will be prohibited. If loads contain wet material capable of producing free liquid, truck liners will be used.

Truck transport routes are as follows:

Outbound Route Headed West on Interstate I-278:

1. Head North on Tiffany Street.
2. Turn left onto Bruckner Boulevard.
3. Continue on Bruckner Boulevard and merge onto I-278 West.

Inbound Route to Site from the West via I-278:

1. Take I-278 west to Bruckner Boulevard.
2. Turn right onto Leggett Avenue.
3. Follow to Randall Avenue.
4. Turn left onto Tiffany Street (Site is on the right).

Inbound and outbound truck routes are shown on Figure 1 of the EWP. All trucks loaded with Site materials will exit the vicinity of the Site using only these approved truck routes. This is the most appropriate route and takes into account: (a) limiting transport through residential areas and past sensitive sites; (b) use of city mapped truck routes; (c) prohibiting offsite queuing of trucks entering the Site; (d) limiting total distance to major highways; (e) promoting safety in access to highways; and (f) overall safety in transport.

Trucks will be prohibited from stopping and idling in the neighborhood outside the Site.

Egress points for truck and equipment transport from the Site will be kept clean of dirt and other materials during Site development.

Queuing of trucks will be performed onsite in order to minimize offsite disturbance. Offsite queuing will be prohibited.

## **C-6 MATERIALS DISPOSAL OFFSITE**

All material exceeding Unrestricted Use criteria to be excavated and removed from the Site will be treated as contaminated and regulated material and will be transported and disposed in accordance with all local, State and Federal regulations. If disposal of material from this Site is proposed for unregulated offsite disposal (i.e., soil meeting unrestricted use criteria), a formal request with an associated plan will be made to the NYSDEC. Unregulated offsite management of materials from this Site will not occur without formal NYSDEC approval.

Offsite disposal locations for excavated soils will be identified in the pre-excavation notification. This will include estimated quantities and a breakdown by class of disposal facility if appropriate, i.e. hazardous waste disposal facility, solid waste landfill, petroleum treatment facility, construction and demolition debris recovery facility, etc. Actual disposal quantities and associated documentation will be reported to the NYSDEC in the Periodic

Review Report. This documentation will include waste profiles, test results, facility acceptance letters, manifests, bills of lading, and facility receipts.

Non-hazardous historic fill and contaminated soils taken offsite will be handled consistent with 6NYCRR Parts 360, 361, 362, 363, 364, and 365. Material that does not meet Unrestricted Use Soil Cleanup Objective (UUSCOs) is prohibited from being taken to a New York State construction and demolition debris recovery facility (6NYCRR Subpart 361-5 registered or permitted facility).

## **C-7 MATERIALS REUSE ONSITE**

If any additional soil is required for reuse onsite, samples will be collected at the frequency required by NYSDEC DER-10 Section 5.4(e)10. Grab soil samples collected will be submitted for the following analyses:

- Target Compound List (TCL)/Part 375 volatile organic compounds (VOCs).

Composite soil samples collected will be submitted for the following analyses:

- TCL/Part 375 semivolatile organic compounds (SVOCs);
- TCL/Part 375 pesticides;
- Herbicides;
- Polychlorinated biphenyls (PCBs);
- Target Analyte List (TAL) metals; and
- Hexavalent/trivalent chromium.

Soil samples will be collected from either in-situ soil or stockpiled soil, whichever is more practical given the state of redevelopment at the time of sampling. All soil excavated for reuse onsite will be screened with a PID and inspected for evidence of impact including odor, staining, and elevated PID readings. Any soil that is observed to be impacted will not be reused onsite and will be segregated for offsite disposal. The qualified environmental professional will ensure that procedures defined for materials reuse in this SMP are followed and that unacceptable material does not remain onsite. All soil designated for reuse onsite will be staged in accordance with the EWP and reused in accordance with NYSDEC DER-10 Section 5.4(e)4.

Any demolition material proposed for reuse onsite will be sampled for asbestos and the results will be reported to the NYSDEC for acceptance. Concrete crushing or processing onsite will not be performed without prior NYSDEC approval. Organic matter (wood, roots, stumps, etc.) or other solid waste derived from clearing and grubbing of the Site will not be reused onsite.

## **C-8 FLUIDS MANAGEMENT**

All liquids to be removed from the Site, including but not limited to, excavation dewatering, decontamination waters, and groundwater monitoring well purge and development waters, will be handled, transported, and disposed in accordance with applicable local, State, and Federal regulations. Dewatering, purge, and development fluids will not be recharged back to the land surface or subsurface of the Site, and will be managed offsite, unless prior approval is obtained from NYSDEC.

Discharge of water generated during large-scale construction activities to surface waters (i.e. a local pond, stream or river) will be performed under a New York City Department of Environmental Protection Temporary Groundwater Discharge Permit.

## **C-9 BACKFILL FROM OFF-SITE SOURCES**

All materials proposed for import onto the Site will be approved by the qualified environmental professional and will be in compliance with provisions in this SMP prior to receipt at the Site. A Request to Import/Reuse Fill or Soil form, which can be found at <http://www.dec.ny.gov/regulations/67386.html>, will be prepared and submitted to the NYSDEC project manager allowing a minimum of 5 business days for review.

Material from industrial sites, spill sites, or other environmental remediation sites or potentially contaminated sites will not be imported to the Site.

All imported soils will meet the backfill soil quality standards established in 6NYCRR 375-6.7(d). Soils that meet 'exempt' fill requirements under 6 NYCRR Part 360,

but do not meet backfill soil objectives for this Site, will not be imported onto the Site without prior approval by NYSDEC. Solid waste will not be imported onto the Site.

Trucks entering the Site with imported soils will be securely covered with tight fitting covers. Imported soils will be stockpiled separately from excavated materials and covered to prevent dust releases.

## **C-10 STORMWATER POLLUTION PREVENTION**

Erosion and sediment control measures will be inspected on a regular basis, however, the Site is exempt from the NYSDEC SPDES General Permit for Stormwater Discharges from Construction Activity (Permit No. GP-0-15-002) requirement, as it is solely serviced by combined sewers and is therefore exempt from a stormwater pollution prevention plan (SWPPP).

## **C-11 EXCAVATION CONTINGENCY PLAN**

If underground tanks or other previously unidentified contaminant sources are found during post-remedial subsurface excavations or development related construction, excavation activities will be suspended until sufficient equipment and personnel are mobilized to address and monitor the condition is present at the Site.

Sampling will be performed on product, sediment and surrounding soils, etc. as necessary to determine the nature of the material and proper disposal method. Chemical analysis will be performed for a full list of analytes (TAL metals, TCL VOCs, TCL SVOCs, TCL pesticides, and PCBs), unless the Site history and previous sampling results provide a sufficient justification to limit the list of analytes. In this case, a reduced list of analytes will be proposed to the NYSDEC for approval prior to sampling.

Identification of unknown or unexpected contaminated media identified by screening during invasive Site work will be promptly communicated by phone to NYSDEC's Project Manager. Reportable quantities of petroleum product will also be

reported to the NYSDEC spills hotline. These findings will be also included in the Periodic Review Report.

## **C-12 COMMUNITY AIR MONITORING PLAN**

The Remedial Action (RA) for this Site achieved a Track 2 Restricted Residential remedy through the excavation of fill material, excavation of soil in areas of the Site identified during the Remedial Investigation (RI) as exceeding Restricted Residential Soil Cleanup Objectives (RRSCOs) and/or Protection of Groundwater Soil Cleanup Objectives (PGWSCOs), removal of underground storage tanks (USTs), and excavation of petroleum-contaminated soil associated with the former petroleum source area and closure of spill # 0812579. A total of 119 post-excavation endpoint samples and seven duplicate samples were collected to determine that Track 2 SCOs were achieved. Therefore, the Community Air Monitoring Plan (CAMP) will not be implemented during future excavation for redevelopment at the Site.

If unknown or unexpected contaminated media identified, including grossly contaminated soil or groundwater, NYSDEC will be notified and the CAMP may be implemented, if deemed appropriate. The CAMP is included within Appendix H of the HASP, which is located in Appendix H of this SMP.

The location of air monitoring stations will be based on generally prevailing wind conditions at the Site. These locations will be adjusted on a daily or more frequent basis based on actual wind directions to provide an upwind and a downwind monitoring station.

Exceedances of action levels listed in the CAMP will be reported to NYSDEC and NYSDOH Project Managers.

## **C-13 ODOR CONTROL PLAN**

This odor control plan is capable of controlling emissions of nuisance odors offsite. Specific odor control methods to be used on a routine basis will include limiting the area of open excavations an size of soil stockpiles, shrouding open excavations with tarps and other covers, and using foams to cover exposed odorous soils, if necessary. If nuisance

odors are identified at the Site boundary, or if odor complaints are received, work will be halted and the source of odors will be identified and corrected. Work will not resume until all nuisance odors have been abated. NYSDEC and NYSDOH will be notified of all odor events and of any other complaints about the project. Implementation of all odor controls, including the halt of work, is the responsibility of the remedial party's Remediation Engineer, and any measures that are implemented will be discussed in the Periodic Review Report.

All necessary means will be employed to prevent onsite and offsite nuisances. At a minimum, these measures will include: (a) limiting the area of open excavations and size of soil stockpiles; (b) shrouding open excavations with tarps and other covers; and (c) using foams to cover exposed odorous soils. If odors develop and cannot be otherwise controlled, additional means to eliminate odor nuisances will include: (d) direct load-out of soils to trucks for offsite disposal; (e) use of chemical odorants in spray or misting systems; and, (f) use of staff to monitor odors in surrounding neighborhoods.

If nuisance odors develop during intrusive work that cannot be corrected, or where the control of nuisance odors cannot otherwise be achieved due to onsite conditions or close proximity to sensitive receptors, odor control will be achieved by sheltering the excavation and handling areas in a temporary containment structure equipped with appropriate air venting/filtering systems.

#### **C-14 DUST CONTROL PLAN**

A dust suppression plan that addresses dust management during invasive onsite work will include, at a minimum, the items listed below:

- Dust suppression will be achieved through the use of a dedicated onsite water truck for road wetting. The truck will be equipped with a water cannon capable of spraying water directly onto off-road areas including excavations and stockpiles.
- Clearing and grubbing of larger sites will be done in stages to limit the area of exposed, unvegetated soils vulnerable to dust production.



- Gravel will be used on roadways to provide a clean and dust-free road surface.
- Onsite roads will be limited in total area to minimize the area required for water truck sprinkling.

## **C-15 OTHER NUISANCES**

A plan for rodent control will be developed and utilized by the contractor prior to and during site clearing and site grubbing, and during all development work.

**TABLES**

1. Notifications (Embedded)

1. Truck Route Map

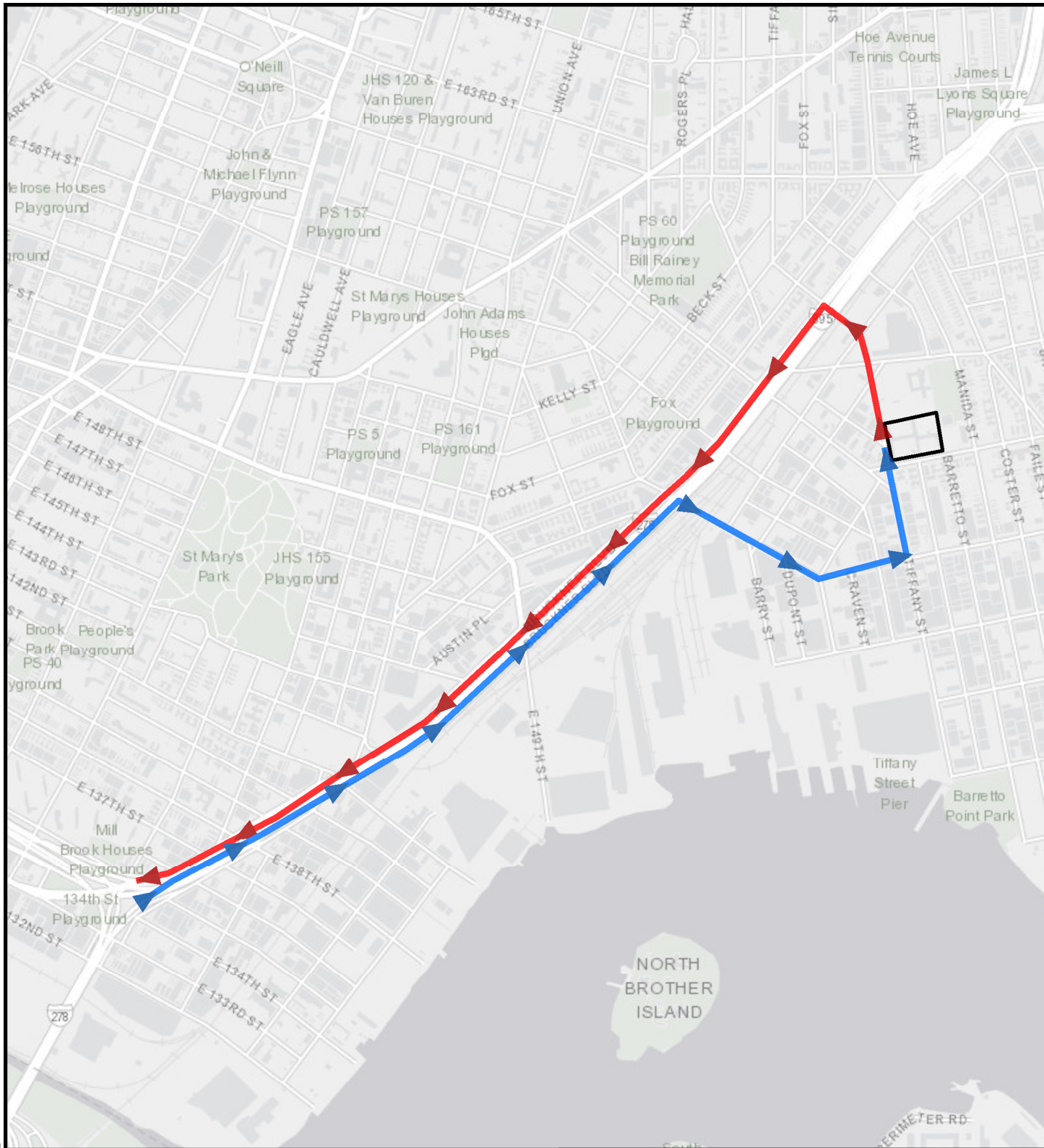

V:\GIS\PROJECTS\2611\0002Y173\2611.0002Y173.6.MXD

**LEGEND**

- TRUCK INGRESS ROUTE
- TRUCK INGRESS ROUTE
- SITE BOUNDARY



Title:

# TRUCK ROUTE MAP

EXCAVATION WORK PLAN  
1221 SPOFFORD AVENUE, BRONX, NY

Prepared for:

THE PENINSULA JV, LLC



Compiled by: P.R.	Date: 04/17/20
Prepared by: M.S.R.	Scale: AS SHOWN
Project Mgr: L.D.	Project: 2611.0002Y000
File: 2611.0002Y173.6.mxd	

FIGURE

1

Site-Specific Health and Safety Plan



# Site-Specific Health and Safety Plan

---

1221 Spofford Avenue  
Tax Lots 35, 36, and 37 of Block 2738  
Bronx, New York

November 2, 2020

Prepared for:

**The Peninsula JV, LLC**  
7 Jackson Walkway  
Providence, Rhode Island 02903

Prepared by:

**Roux Environmental Engineering  
and Geology, D.P.C.**  
209 Shafter Street  
Islandia, New York 11749

# Table of Contents

Site-Specific Emergency Information .....	1
Emergency Phone Numbers .....	1
1. Introduction .....	3
1.1 Roles and Responsibilities .....	3
2. Background .....	6
2.1 Site Description .....	6
2.2 Site History .....	6
2.3 Known and Potential Releases of Hazardous Substances at the Site .....	6
3. Scope of Work .....	8
4. Site Control .....	9
4.1 Site Map .....	9
4.2 Site Access .....	9
4.3 Buddy System .....	9
4.4 Site Communications .....	9
4.5 Site Work Zones .....	10
5. Job Hazard Evaluation .....	12
5.1 Hazard Communication and Overall Site Information Program .....	13
6. Emergency Response Plan .....	14
6.1 Emergency Response .....	14
6.2 Emergency Alerting and Evacuation .....	14
6.3 Emergency Medical Treatment and First Aid .....	14
6.4 Adverse Weather Conditions .....	16
6.5 Electrical Storm Guidelines .....	16
7. Safety Procedures .....	17
7.1 Training .....	17
7.2 Site-Specific Safety Briefings for Visitors .....	17
7.3 HASP Information and Site-Specific Briefings for Workers .....	17
7.4 Medical Surveillance .....	18
7.4.1 Site Medical Surveillance Program .....	18
7.4.2 Medical Recordkeeping Procedures .....	18
7.4.3 Program Review .....	18
7.5 Personnel Protection .....	19
7.5.1 Hearing Conservation .....	20
7.6 Monitoring .....	20
7.6.1 Action Levels for Air Monitoring .....	20
7.6.2 Air Monitoring Equipment and Calibration .....	22
7.7 Tailgate Safety Meetings .....	23
7.8 Spill Containment .....	23
7.8.1 Initial Spill Notification and Response .....	23
7.8.2 Spill Evaluation and Response .....	23

## Table of Contents (Continued)

7.9 Decontamination.....	23
7.9.1 Decontamination Procedures for Personnel and PPE.....	24
7.9.2 Decontamination Procedures for Equipment.....	24
7.9.3 Monitoring the Effectiveness of Decontamination Procedures.....	25
7.10 Confined Space Entry.....	25
7.11 Client and Site-Specific.....	26
7.12 Unusual or Significant Risks.....	26
7.13 Activity-Specific.....	26
7.13.1 Electrical and Other Utility Assessment and Accommodations.....	26
7.13.2 Subsurface Work.....	26
7.13.2.1 Excavations and Trenching.....	27
7.13.3 Heavy Equipment.....	27
7.14 Heat Stress.....	28
7.14.1 Heat Stress.....	28
7.14.2 Heat Exhaustion.....	28
7.14.3 Heat Stroke.....	29
7.15 Cold Stress.....	29
7.16 COVID-19.....	30
8. Field Team Review.....	31
9. Approvals.....	32

## Tables

1. Toxicological, Physical, and Chemical Properties of Compounds Potentially Present at 1221 Spofford Avenue, Bronx, New York

## Figures

1. Site Location Map
2. Site Plan
3. Directions to Bronx Lebanon Hospital Center
4. Directions to City MD

## Appendices

- A. Job Safety Analysis (JSA) Forms
- B. SDSs for Chemicals Used
- C. Personal Protective Equipment (PPE) Management Program
- D. Subsurface Utility Clearance Management Program
- E. Heavy Equipment Exclusion Zone Policy
- F. Roux COVID-19 Interim Health and Safety Guidance
- G. CDC's Face Covering Procedure
- H. Community Air Monitoring Plan (CAMP)



# Site-Specific Emergency Information

## Emergency Phone Numbers

Most emergency services can be obtained by calling **911**. Where 911 service is not available, use the telephone numbers provided in the below table. The following is a master emergency phone list for use by the project management personnel. A more condensed version of the emergency numbers listed below will be posted throughout project work areas. Emergencies encountered on the site will be responded to by a combination of off-site emergency services and site personnel.

Emergency Contact Information			
Site Personnel			
Title	Contact	Telephone	
Project Manager (PM)	Lauren Dolginko	631-630-2415	
Project Principal (PP)	Frank Cherena	631-630-2388	
Site Supervisor (SS)	TBD	--	
Site Health and Site Safety Officer (SHSO)	TBD	--	
Office Health and Safety Manager (OHSM)	Kristina DeLuca	631-630-2406	
Corporate Health and Safety Manager (CHSM)	Brian Hobbs	631-630-2419	
Client Emergency Contact	Joshua Weisstuch	646-216-5283	
Outside Assistance			
Agency	Contact	Telephone	Address/Location
Ambulance/emergency medical services (EMS)	Hunter Ambulance	516-371-0870	1028 Freeman Street, Bronx, New York
Police	NYPD – 43 <sup>rd</sup> Precinct	718-542-0888	900 Fteley Avenue, Bronx, New York
Fire	FDNY – Engine 96, Ladder 54	212-639-9675	1689 Story Avenue, Bronx, New York
Site Address	1221 Spofford Avenue, Bronx, New York 10474		

### Directions to Bronx Lebanon Hospital Center (Figure 3)

853 Tiffany Street  
Bronx, New York, 10459

- Head west on Spofford Avenue toward Tiffany Street (187 feet);
- Turn right onto Tiffany Street (0.3 mi);
- Slight left near Garrison Ave;
- Destination will be on the left.

### Directions to City MD (Figure 4)

80 West 125th Street

New York, New York

1221 Spofford Avenue, Bronx, New York;

- Head west on Spofford Avenue toward Tiffany Street (413 feet);
- Turn Right onto Longwood Avenue (0.2 mi);
- Turn left at the 3rd cross street onto Bruckner Blvd (1.0 mi);
- Keep left to stay on Bruckner Blvd (1.2 mi);
- Use middle lane to continue on Third Avenue Bridge (0.3 mi);
- Keep right to stay on Third Avenue Bridge (243 ft);
- Continue straight on E 129th Street (0.3 mi);
- Turn left onto 5th Avenue. (0.2 mi);
- Turn right onto West 125th Street, destination will be on the left (0.2 mi).

# 1. Introduction

This Site-specific Health and Safety Plan (HASP) has been prepared by Roux Environmental Engineering and Geology, D.P.C. (Roux) for use during the sampling, remedial activities, and oversight being performed by Roux at the Peninsula Redevelopment Project, owned by The Peninsula JV, LLC (“the Site”), located at 1221 Spofford Avenue, Bronx, NY 10474 (see Figure 1). These activities fall within the scope of operations covered by the Occupational Safety and Health Administration (OSHA) standards promulgated at 29 CFR 1910.120 and 29 CFR 1926.65, both commonly referred to as the Hazardous Waste Operations and Emergency Response (HAZWOPER) Standard. In accordance with the HAZWOPER Standard, this Site-specific HASP was prepared to address the safety and health hazards associated with the sampling, remedial activities, and oversight being performed at the Site by Roux and to provide requirements and procedures for the protection of Roux employees, subcontractor personnel, government oversight personnel, Site personnel, and the general public. It also addresses client- and Site-specific requirements for health and safety.

Implementation of this HASP is the joint responsibility of the Project Manager (PM), the Site Health and Safety Officer (SHSO), and all field staff, with assistance from the Project Principal (PP), Office Health and Safety Manager (OHSM), and Corporate Health and Safety Manager (CHSM). The PM for this project is Lauren Dolginko. The Site Supervisor (SS) is yet to be determined and Site Health and Safety Officer (SHSO) is yet to be determined.

This HASP will be introduced to, reviewed, and signed off on by all Roux personnel through a formal training session prior to commencing work. A copy of the HASP will be kept at the Site at all times. The Roux SHSO or PM will be responsible for posting any changes, amendments, memos, etc. to the HASP. Any revisions to this HASP will be signed by appropriate personnel, which can include Roux’s PP, CHSM, and SS. Any changes will be announced to all workers at the next safety meeting.

## 1.1 Roles and Responsibilities

Overall Roles and Responsibilities (R&Rs) of Roux personnel are provided in Roux’s Policies and Procedures Manual. Only those R&Rs specific to HASP requirements are listed below.

### Project Manager (PM)

The PM has responsibility and authority to direct all work operations. The PM coordinates safety and health functions with the Site Health and Safety Officer (SHSO), has the authority to oversee and monitor the performance of the SHSO, and bears ultimate responsibility for the proper implementation of this HASP. The specific duties of the PM are:

- preparing and coordinating the Site work plan;
- providing Site supervisor(s) with work assignments and overseeing their performance; Coordinating safety and health efforts with the SHSO;
- ensuring effective emergency response through coordination with the Emergency Response Coordinator (ERC);
- serving as primary Site liaison with public agencies and officials and Site contractors.

### **Site Health and Safety Officer (SHSO)**

The SHSO has full responsibility and authority to develop and implement this HASP and to verify compliance. The SHSO reports to the Project Manager. The SHSO is onsite or readily accessible to the Site during all work operations and has the authority to halt Site work if unsafe conditions are detected. The specific responsibilities of the SHSO include:

- managing the safety and health functions on this Site;
- serving as the Site's point of contact for safety and health matters;
- ensuring Site monitoring, worker training, and effective selection and use of PPE;
- assessing Site conditions for unsafe acts and conditions and providing corrective action;
- assisting the preparation and review of this HASP;
- maintaining effective safety and health records as described in this HASP; and
- coordinating with the Site Supervisor(s) and others as necessary for safety and health efforts.

### **Site Supervisor**

The Site Supervisor is responsible for field operations and reports to the Project Manager (PM). The Site Supervisor ensures the implementation of the HASP requirements and procedures in the field. The specific responsibilities of the Site Supervisor include:

- executing the work plan and schedule as detailed by the PM;
- coordination with the SHSO on safety and health; and
- ensuring Site work compliance with the requirements of this HASP.

### **Employees**

All Roux employees are responsible for reading and following all provisions of the Corporate Health and Safety Manual, including this HASP. Employees report to the SS at the project Site. Each employee is also responsible for the following:

- wearing all appropriate PPE as outlined within this HASP;
- attending all safety meetings;
- inspecting tools and equipment prior to use, and taking any defective tools or equipment out of service;
- appropriately documenting field events as they occur within a logbook or equivalent;
- properly operating machinery and/or equipment only if trained to do so;
- stopping work operations if unsafe conditions exist;
- identifying and mitigating hazards when observed;
- reporting all incidents and near misses to the Roux SHSO and SS immediately; and
- knowing where emergency equipment is located (e.g. first aid kit, fire extinguisher).

### **Subcontractors and Visitors**

Subcontractors and visitors are responsible for complying with the same health and safety requirements. It is the responsibility of all to make sure subcontractors and visitors comply and uphold the HASP. Subcontractors and visitors have the following additional responsibilities:

- designating a qualified safety representative for the project that can make the necessary changes in work practices, as necessary;
- attending all safety meetings while participating in Roux Site work activities;
- reporting all incidents and near misses to Roux SHSO and SS immediately;
- conducting initial and periodic equipment inspections in accordance with manufacturer and regulatory guidelines; and
- providing copies of all Safety Data Sheets (SDS) to Roux SHSO for materials brought to the Site.

## 2. Background

Relevant background information is provided below, including a general description of the Site; a brief review of the Site's history with respect to hazardous material use, handling, and/or storage; and a review of known and potential releases of hazardous substances at the Site.

### 2.1 Site Description

The Site is located in the Borough of Bronx, City and State of New York and is identified as Tax Lots 35, 36, and 37 of Tax Block 2738 on the New York City Tax Map. Figure 1 is a Site Location Map and Figure 2 is a Site Plan. The Site is approximately 165,528-square feet (3.78 acres) and is bordered to the south by mixed use multi-family residential properties and commercial properties. The Corpus Christi Monastery is located to the north of the Site. Multi/single-family residential properties and commercial properties are located west of the Site. Single-family residential properties are located to the east of the Site.

The Site consists of the following buildings and improvements:

Two buildings on the west side of the Site, Building 1A and Building 1B, are currently under construction. The east side of the Site is currently an empty lot following remedial excavation and is devoid of permanent buildings or structures and is the future location of Building 2A and Building 2B. The east side of the Site will remain a combination of exposed soil and bedrock until future redevelopment activities commence to construct Building 2A and Building 2B.

### 2.2 Site History

The Site was previously the location of the former Spofford Juvenile Detention Facility, later renamed as Bridges Juvenile Center, which was in operation from its construction in 1956 through 2011. The Site was temporarily closed from 1998 to 1999. Based on a 1951 Sanborn® Fire Insurance Map, a "Stone Yard", a dwelling, and "coops" are depicted in northwestern portion of the Site, two residential dwellings are depicted in the eastern portion of the Site and one residential dwelling is depicted in the southern portion of the Site. It appears that the residential buildings on the east side of the Site were demolished, and the ACS Child Care facility was constructed by 1975.

### 2.3 Known and Potential Releases of Hazardous Substances at the Site

Historical evidence supporting the potential occurrence of releases exists in two forms, those supported by documentation, and those based on the knowledge of Client personnel. These incidents are presented below by geographical area with documented information first, then "knowledge" information procured from Client personnel. Locations of the tanks, buildings, and Site features mentioned in this HASP are shown on maps maintained in onsite files.

A Phase I Environmental Site Assessment (ESA) completed in 2017 identified the following recognized environmental concerns (RECs):

1. Reported Spill Incidents: New York State Department of Conservation (NYSDEC) Spill Numbers 9610764, 9901578 and 0812579 were assigned the Site (specifically Lot 35). Spill #9610764 was assigned for a release of 40 gallons of #6 fuel oil due a faulty gauge; and was closed on the same day it was assigned. NYSDEC Spill #9901578 was assigned for discovery of contaminated soil

during a subsurface investigation; and was closed on April 6, 2017. Spill # 0812579 was assigned for the release of approximately 2,000 gallons of #2 fuel oil from the underground storage tanks (USTs) located in the southeast courtyard of Lot 35. Several investigations have been performed confirming subsurface soil and groundwater impacts. A product recovery program consisting of monthly product recovery and quarterly groundwater monitoring was performed until approximately October 2016. All separate phase petroleum product and soil contamination related to spill # 0812579 was removed from the Site during remedial excavation in April and May 2020. Now that remediation and removal has been completed, spill # 0812579 is in the process of being closed.

2. **Petroleum Use and Storage:** Two 12,000-gallon #2 fuel oil USTs were registered as in-service at the Site under NYSDEC Petroleum Bulk Storage (PBS) #2-604085; and were located in the in the southeast courtyard of Lot 35. In addition, one 5,000-gallon diesel aboveground storage tank (AST), located in a vault adjacent to the 12,000-gallon USTs, was utilized for a back-up generator was closed-in-place. The location of two additional tanks (one 20,000 gallon #6 fuel oil UST; and one 20,000-gallon AST were, reportedly, closed-in-place. During remedial excavation at the Site, the two additional tanks were uncovered and removed from by a FDNY-licensed tank removal contractor.
3. **Staining:** Staining observed on the concrete basement floor was presumably associated with oil spills and cleanup materials, and other universal wastes (such as batteries or degreasers, electrical equipment, and lubricating oils). The concrete basement floor was demolished during redevelopment activities at the Site. All concrete debris generated, including the stained concrete debris, was removed from the Site during remedial excavation. All stained soil discovered underneath the former concrete basement floor during remediation was also removed from the Site.

**Surrounding Property Use:** According to the resources utilized in this Phase I ESA, garages utilizing USTs as well as metal works/fabrication and automobile repair facilities were noted in the surrounding area of the Site. USTs have the potential to release petroleum products to the environment and metal works/fabrication and automobile repair facilities have the potential for using solvents and petroleum products. Therefore, these surrounding properties are, collectively, considered a REC in relation to the Site.

Since the completion of the Phase I ESA, the following activities have occurred to address the onsite RECs:

- Remedial excavation of the site included the removal of impacted soil and bedrock related to NYSDEC Spill #0812579.
- The two 12,000-gallon #2 fuel oil USTs are registered as in-service at the site under NYSDEC Petroleum Bulk Storage (PBS) #2-604085 and the one 5,000-gallon diesel aboveground storage tank (AST), located in a vault adjacent to the 12,000-gallon USTs, were all removed from the site during demolition and remedial excavation.
- Remedial excavation activities at the site also included the removal of building walls, slabs and floors, including the concrete basement floor which previously exhibited staining related to NYSDEC Spill #0812579. These structures, including the stained concrete basement floor, were demolished during remedial excavation as they were uncovered and removed from the Site.

All of the onsite RECs listed above have been addressed during the remediation. There are no longer health and safety concerns related to the former RECs.

### **3. Scope of Work**

The scope of work will include the following:

- Oversight of excavations and backfill;
- Possible collection of soil samples related to redevelopment;
- Site inspections;
- Community Air Monitoring, when applicable; and
- Possible collection of groundwater samples.

Detailed scopes of work for these activities will be prepared prior to implementation of the tasks.

If there are any changes with the scope a revision of the HASP will be required to address any new hazards.



## 4. Site Control

This Site control program is designed to reduce the spread of hazardous substances from contaminated areas to clean areas, to identify and isolate contaminated areas of the Site, to facilitate emergency evacuation and medical care, to prevent unauthorized entry to the Site, and to deter vandalism and theft.

### 4.1 Site Map

A map of this Site, showing Site boundaries, designated work zones, and points of entry and exit is provided in Figure 2.

### 4.2 Site Access

Access to the Site is restricted to reduce the potential for exposure to its safety and health hazards. During hours of Site operation, Site entry and exit is authorized only at the points identified in Figure 2. Entry and exit at these points is controlled by the following: security guards and gates/turnstiles. When the Site is not operating, access to the Site is controlled by the following: security guards and gates/turnstiles.

### 4.3 Buddy System

This section is not applicable for all components of the SOW described in Section 3. Some Site inspections, sample collection activities, and oversight are completed by a single Roux employee. However, when completing these tasks, the single Roux employee is accompanied either by Roux subcontractors or the Site caretaker/other representatives from The Peninsula JV, LLC. Any time Roux is onsite, The Peninsula JV, LLC is made aware and communications with The Peninsula JV, LLC and the Roux PM is maintained via cellular phone.

While working in the Exclusion Zone, Site workers use the buddy system. The buddy system means that personnel work in pairs and stay in close visual contact to be able to observe one another and summon rapid assistance in case of an emergency. The responsibilities of workers using the buddy system include:

- Remaining in close visual contact with partner;
- Providing partner with assistance as needed or requested;
- Observing partner for signs of heat stress or other difficulties;
- Periodically checking the integrity of partner's PPE; and
- Notifying the Site manager or other Site personnel if emergency assistance is needed.

### 4.4 Site Communications

The following communication equipment is used to support onsite communication: cell phones, walkie-talkies, and visual hand signals.

As applicable, hand signals will be used according to the following:

## Hand Signals

SIGNAL	MEANING
Hand gripping throat	Out of air, can't breathe
Grip partner's wrist	Leave area immediately
Hands on top of head	Need assistance
Thumbs up	I'm all right, okay
Thumbs down	No, negative

A current list of emergency contact numbers is posted in the following locations: onsite trailers and site fences near the entrances.

### 4.5 Site Work Zones

This Site is divided into three (3) major zones, described below. These zones are characterized by the presence or absence of biological, chemical, or physical hazards and the activities performed within them. Zone boundaries are clearly marked at all times and the flow of personnel among the zones is controlled. The Site is monitored for changing conditions that may warrant adjustment of zone boundaries. Zone boundaries are adjusted as necessary to protect personnel and clean areas. Whenever boundaries are adjusted, zone markings are also changed, and workers are immediately notified of the change.

#### Exclusion Zone

The area where contamination exists is the Exclusion Zone (EZ). All areas where excavation and handling of contaminated materials take place are considered the EZ. This zone will be delineated by orange high visibility fencing. Safety tape may be used as a secondary delineation within the EZ. The zone delineation markings may be opened in areas for varying lengths of time to accommodate equipment operation or specific construction activities. The SHSO may establish more than one EZ where different levels of protection may be employed or where different hazards exist. Personnel are not allowed in the EZ without:

- A buddy (co-worker)
- Required minimum level PPE
- Medical Authorization
- Training certification
- Requirement to be in the zone

#### Contamination Reduction Zone

A Contamination Reduction Zone (CRZ) is established between the exclusion zone and the support zone. The CRZ contains the Contamination Reduction Corridor (CRC) and provides an area for decontamination

of personnel and equipment. The CRZ will be used for general Site entry and egress in addition to access for heavy equipment and emergency support services. Personnel are not allowed in the CRZ without:

- A buddy (co-worker)
- Appropriate PPE
- Medical authorization
- Training certification
- Requirement to be in the zone

### **Support Zone**

The Support Zone (SZ) is an uncontaminated area that will be the field support area for the Site operations. The SZ will contain the temporary project trailers and provides for field team communications and staging for emergency response. Appropriate sanitary facilities and safety equipment will be located in this zone. Potentially contaminated personnel or materials are not allowed in this zone. The only exception will be appropriately packaged/decontaminated and labeled samples.

## 5. Job Hazard Evaluation

Roux's work at the Site is expected to entail a variety of physical, chemical, and biological hazards, all of which must be sufficiently managed to allow the work to be performed safely. Some of the hazards are Site-specific, i.e., they are associated with the nature, physical characteristics, and/or routine operation of the Site itself, while others are activity-specific, i.e., they are associated with (or arise from) the particular activity being performed. The various hazards can be grouped into the following categories:

- **Caught/Crushed** – the potential to become caught in, under, between, or by an object or parts of an object, such as equipment with parts that open and close or move up and down (“pinch points”) or equipment that rotates, and the accompanying potential to have body parts cut, mangled, or crushed thereby.
- **Contact** – the potential to be struck by or against moving or stationary objects that can cause physical injury, such as heavy machinery, overhead piping, moving vehicles, falling objects, and equipment (including tools and hand-held equipment) or infrastructure with the ability to cut or impale.
- **Energy Sources** – the potential for bodily harm associated with energy sources, most notably electricity, but also including latent energy sources such as compressed air and equipment under tension (which when released could cause injurious contact or a fall).
- **Ergonomics** – the potential for musculoskeletal injury associated with lifting/carrying, pushing/pulling, bending, reaching, and other physical activity attributable to poor body position/mechanics, repetitive motion, and/or vibration.
- **Exposure** – the potential for injury/illness due to physical, chemical, or biological exposures in the work environment, including but not limited to temperature extremes, solar radiation, and noise (physical), chemical splashes and hazardous atmospheres (chemical), and animal/insect bites and poisonous plants (biological).
- **Falls** – the potential to slip or trip and thus fall or drop a load, resulting in bodily injury to oneself or others.

The foregoing is intended to provide Roux employees with a general awareness of the hazards involved with Site work. A more detailed review of the potential hazards associated with each specific activity planned for the Site (or ongoing activity, as the case may be) is provided in the activity-specific Job Safety Analysis (JSA) forms in **Appendix A**. As can be seen in the JSA forms, the hazards are identified by category per the above, and specific measures designed to mitigate/manage those hazards are also identified. In preparing the JSA forms, all categories of hazards were considered, and all anticipated potential hazards were identified to the extent possible based on the experience of the personnel preparing and reviewing the JSA forms. However, there is always the possibility for an unanticipated hazard to arise, potentially as condition change over the course of the workday. Roux personnel must maintain a continual awareness of potential hazards in the work zone, regardless of whether the hazard is identified in the JSA form. Particular attention should be paid to hazards associated with exposure to hazardous substances (see Table 1 for a listing of the hazardous substances most likely to be encountered in environmental media at the Site) and to Site personnel being located “in the line of fire” with respect to moving equipment, pinch points, and latent energy, e.g., being located or having body parts located within the swing radius of an excavator, between two sections of pipe being connected, below a piece of suspended equipment, or adjacent to a compressed air line.

## **5.1 Hazard Communication and Overall Site Information Program**

The information in the JSAs and safety data sheets is made available to all employees and subcontractors who could be affected by it prior to the time they begin their work activities. Modifications to JSAs are communicated during routine pre-work briefings.

## 6. Emergency Response Plan

This emergency response plan details actions to be taken in the event of Site emergencies. The PM and SHSO is responsible for the implementation of emergency response procedures onsite. The SHSO/PM provides specific direction for emergency action based upon information available regarding the incident and response capabilities and initiates emergency procedures and notification of appropriate authorities. In the event of an emergency, Site personnel are evacuated and do not participate in emergency response activities, response is facilitated through external emergency services.

### 6.1 Emergency Response

The SHSO, after investigating the incident and relevant information, shall determine the level of response required for containment, rescue and medical care. Limited onsite emergency response activities could occur therefore the SHSO is responsible for notifying external emergency response agencies. The SHSO provides relevant information to the responding organizations, including but not limited to the hazards associated with the emergency incident, potential containment problems, and missing Site personnel.

### 6.2 Emergency Alerting and Evacuation

If evacuation notice is given, Site workers leave the worksite, if possible, by way of the nearest exit. Appropriate primary and alternate evacuation routes and assembly areas have been identified and are shown on the Site Plan, Figure 2. The routes and assembly area will be determined by conditions at the time of the evacuation based on wind direction, the location of the hazard source, and other factors as determined by SHSO/PM.

Personnel exiting the Site gather at a designated assembly point. To determine that everyone has successfully exited the Site, personnel will be accounted for at the assembly Site. If any worker cannot be accounted for, notification is given to so that appropriate action can be initiated. Subcontractors on this Site have coordinated their emergency response plans to ensure that these plans are compatible and potential emergencies are recognized, alarm systems are clearly understood, and evacuation routes are accessible to all personnel relying upon them.

### 6.3 Emergency Medical Treatment and First Aid

In the event of a work-related injury or illness, employees are required to follow the procedures outlined below. All work-place injury and illness situations require Roux's Project and Corporate Management Team to be notified when an injury/illness incident occurs, and communication with the contracted Occupational Health Care Management Provider, AllOne Health (AOH), is initiated. The Injury/Illness Notification Flowchart is provided below and within Roux's Incident Investigation and Reporting program included within Roux's Corporate Health and Safety Manual. In addition, if the person is suspected to be infected with COVID-19 or is suspected to have come into contact with someone infected with COVID-19, follow the Roux COVID-19 Interim Health and Safety Guidance outlined in Appendix F. Additional COVID-19 related documentation, including the CDC's Face Covering Procedure is included as Appendix G, respectively.

If onsite personnel require any medical treatment, the following steps will be taken:

- a. Notify Roux's Project and Corporate Management Team for any work-related injury and/or illness occurrence and communicate with the contracted Occupational Health Care Management Provider, AOH, immediately following the notifications provided above.
- b. Based on discussions with the Project Team, Corporate Management and the AOH evaluation, if medical attention beyond onsite First Aid is warranted, transport the injured / ill person (IP) to the Urgent Care Center, or notify the Fire Department or Ambulance Emergency service and request an ambulance or transport the victim to the hospital, and continue communications with Corporate Management Team. An Urgent Care/Hospital Route map with location to City MD/Bronx Lebanon Hospital Center is included as Figure 3 and Figure 4.
- c. Decontaminate to the extent possible prior to administration of first aid or movement to medical or emergency facilities.
- d. First aid medical support will be provided by onsite personnel trained and certified in First Aid, Cardio Pulmonary Resuscitation (CPR), Automatic External Defibrillation (AED), and Blood-Borne Pathogens (BBP) Awareness, until relieved by emergency medical services (EMS).
- e. The SHSO and Project Manager will perform a Loss Investigation (LI) and the Project Team will complete the final Loss Report. If a Roux employee is involved in a vehicular incident, the employee must also complete the Acord Automobile Loss Notice.

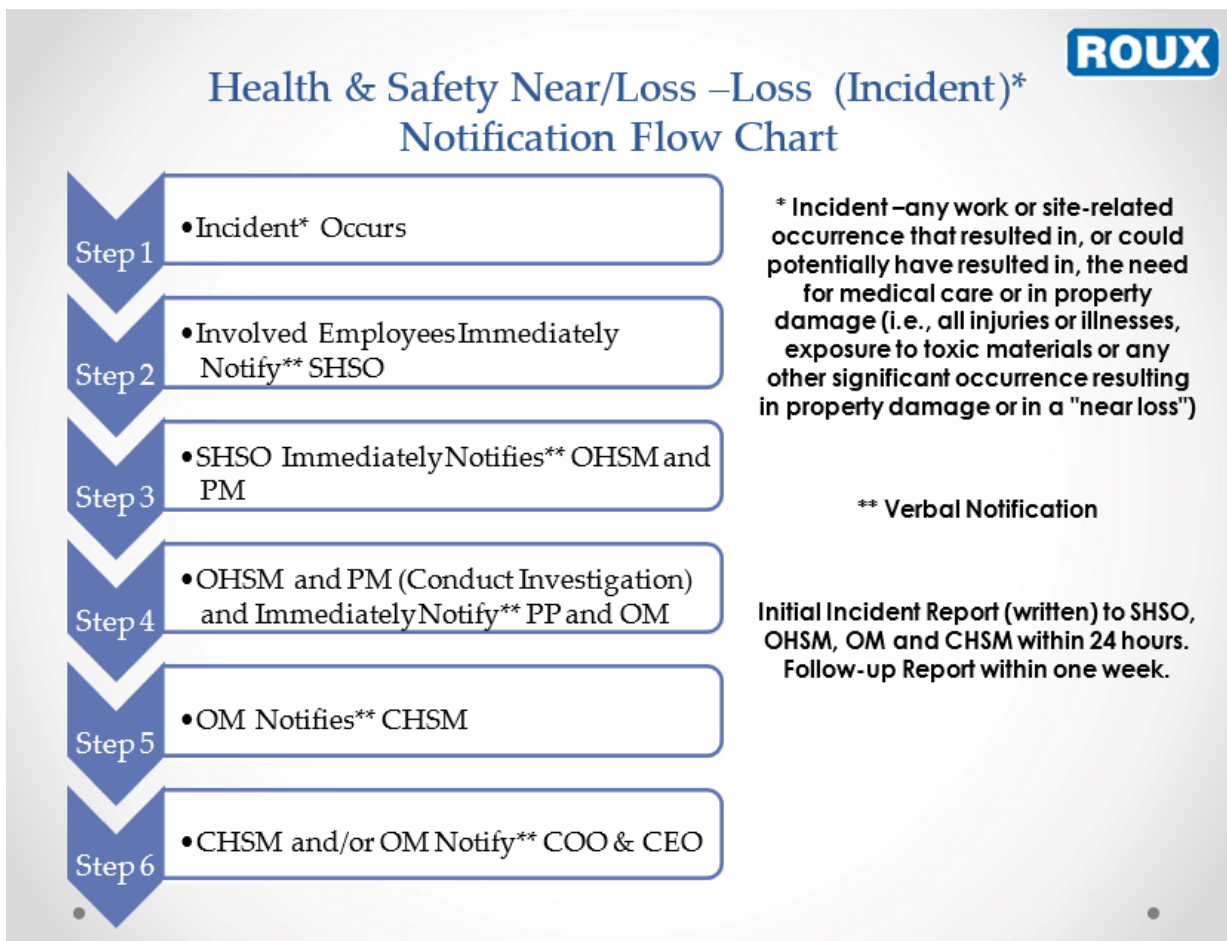

## 6.4 Adverse Weather Conditions

In the event of adverse weather conditions, the SHSO or project principal will determine if work can continue without sacrificing the health and safety of all field workers. Some of the items to be considered prior to determining if work should continue are:

- Potential for heat stress and heat-related injuries.
- Potential for cold stress and cold-related injuries.
- Treacherous weather-related conditions.
- Limited visibility.
- Electrical storm potential.

Site activities will be limited to daylight hours and acceptable weather conditions. Inclement working conditions include heavy rain, fog, high winds, and lightning. Observe daily weather reports and evacuate if necessary in case of inclement weather conditions.

## 6.5 Electrical Storm Guidelines

In the event that lightning and/or thunder are observed while working onsite, all onsite activities shall stop and personnel shall seek proper shelter (e.g., substantial building, enclosed vehicle, etc.). Work shall not resume until the threat of lightning has subsided and no lightning or thunder has been observed for 30 minutes. If the possibility of lightning is forecast for the day, advise the onsite personnel on the risks and proper procedure at the pre-work safety briefing. Continuously monitor for changing weather conditions and allow enough time to properly stop work if lightning is forecast.



## 7. Safety Procedures

This section of the HASP presents the specific safety procedures to be implemented during Roux's activities at the Site in order to protect the health and safety of various onsite personnel. Minimum OSHA-mandated procedures are presented first, followed by client- and Site-specific procedures. Lastly, activity-specific procedures are discussed. These Site and activity-specific procedures supplement the general safety procedures included in Roux's Corporate Health and Safety Manual, which also must be followed in their entirety.

### 7.1 Training

At a minimum, Site personnel who will perform work in areas where there exists the potential for toxic exposure will be health and safety-trained prior to performing work onsite per OSHA 29 CFR 1910.120(e) and 29 CFR 1926.65(e). More specifically, all Roux, subcontractor, and other personnel engaged in sampling and remedial activities at the Site and who are exposed or potentially exposed to hazardous substances, health hazards, or safety hazards must have received at a minimum the 40 hour initial HAZWOPER training consistent with the requirements of 29CFR 1910.120(e)(3)(i) training and a minimum of 3 days' actual field experience under the direct supervision of a trained experienced supervisor, plus 8 hours of refresher training on an annual basis. Depending on tasks performed, less training may be permitted. Evidence of such training must be maintained at the Site at all times. Furthermore, all onsite management and supervisory personnel directly responsible for or who supervise the employees engaged in Site remedial operations, must have received an additional 8 hours of specialized training at the time of job assignment on topics including, but not limited to, the employer's safety and health program and the associated employee training program, personal protective equipment program, spill containment program, and health hazard monitoring procedure and techniques, plus 8 hours of refresher training on an annual basis.

Roux personnel training records are maintained in a corporate database with records available upon request from either the OHSM/SHSO/CHSM or Human Resources Department.

### 7.2 Site-Specific Safety Briefings for Visitors

A site-specific briefing is provided to all site visitors who enter this site beyond the site entry point. For visitors, the site-specific briefing provides information about site hazards, the site lay-out including work zones and places of refuge, the emergency alarm system and emergency evacuation procedures, and other pertinent safety and health requirements as appropriate.

### 7.3 HASP Information and Site-Specific Briefings for Workers

Site personnel review this HASP and are provided a site-specific tailgate briefing prior to the commencement of work to ensure that employees are familiar with this HASP and the information and requirements it contains as well as relevant JSAs. Additional briefings are provided as necessary to notify employees of any changes to this HASP as a result of information gathered during ongoing site characterization and analysis. Conditions for which we schedule additional briefings include, but are not limited to: changes in site conditions, changes in the work schedule/plan, newly discovered hazards, and incidents occurring during site work.

## 7.4 Medical Surveillance

The medical surveillance section of the Health and Safety Plan describes how worker health status is monitored at this site. Medical surveillance is used when there is the potential for worker exposure to hazardous substance at levels above OSHA permissible exposure limits or other published limits. The purpose of a medical surveillance program is to medically monitor worker health to ensure that personnel are not adversely affected by site hazards. The provisions for medical surveillance at this site are based on the site characterization and job hazard analysis found in Section 4 of this HASP and are consistent with OSHA requirements in 29 CFR 1910.120(f) as applicable.

### 7.4.1 Site Medical Surveillance Program

Medical surveillance requirements are based on a worker's potential for exposure as determined by the site characterization and job hazard analysis documented in Section 4 and JSAs within Appendix A of this HASP and in compliance with the requirements of 29 CFR 1910.120(f)(2). Based on site information and use of direct reading instruments, limited use of respirators (less than 30 days per year), and the absence of an employee-staffed HAZMAT team, a limited medical surveillance program is required and implemented at this site. The medical surveillance program provides that:

1. Workers assigned to tasks requiring the use of respirators receive medical examinations in accordance with 29 CFR 1910.134(e) to ensure they are physically capable to perform the work and use the equipment, and
2. If a worker is injured, becomes ill, or develops signs or symptoms of possible over-exposure to hazardous substance or health hazards, medical examinations are provided to that worker as soon as possible after the occurrence and as required by the attending physician.
3. These medical examinations and procedures are performed by or under the supervision of a licensed physician and are provided to workers free of cost, without loss of pay, and at a reasonable time and place. In addition, the need to implement a more comprehensive medical surveillance program will be re-evaluated after any apparent over-exposure.

### 7.4.2 Medical Recordkeeping Procedures

Medical recordkeeping procedures are consistent with the requirements of 29 CFR 1910.1020 and are described in the company's overall safety and health program. A copy of that program is available at our Islandia, New York office.

The following items are maintained in worker medical records:

- Respirator fit test and selection
- Physician's medical opinion of fitness for duty (pre-placement, periodic, termination)
- Physician's medical opinion of fitness for respirator protection (pre-placement, periodic)
- Exposure monitoring results

### 7.4.3 Program Review

The medical program is reviewed to ensure its effectiveness. The Corporate Health and Safety Manager in coordination with the Human Resources Director is responsible for this review. At minimum, this review consists of:

- Review of accident and injury records and medical records to determine whether the causes of accidents and illness were promptly investigated and whether corrective measures were taken wherever possible;
- Evaluation of the appropriateness of required medical tests based on site exposures; and
- Review of emergency treatment procedures and emergency contacts list to ensure they were site-specific, effective, and current.

## 7.5 Personnel Protection

Site safety and health hazards are eliminated or reduced to the greatest extent possible through engineering controls and work practices. Where hazards are still present, a combination of engineering controls, work practices and PPE are used to protect employees. Appropriate personal protective equipment (PPE) shall be worn by Site personnel when there is a potential exposure to chemical hazards or physical hazards (e.g., falling objects, flying particles, sharp edges, electricity and noise), as determined by the SHSO. The level of personal protection, type and kind of equipment selected will depend on the hazardous conditions and in some cases cost, availability, compatibility with other equipment, and performance. An accurate assessment of all these factors will be made before work can be safely executed.

Roux maintains a comprehensive written PPE program that addresses proper PPE selection, use, maintenance, storage, fit and inspection. Roux's PPE program can be found within Appendix C. PPE to be used at the Site will meet the appropriate American National Standards Institute (ANSI) standards and the following OSHA (General/Construction Industry) standards for minimum PPE requirements.

The minimum level of PPE for entry onto the Site is Level D. The following equipment shall be worn:

- Work uniform (long pants, sleeved shirt)
- Hard hat
- Steel or composite toe work boots
- Safety Glasses (must comply with one of the following ANSI/ISEA Z87.1-2010, ANSI Z87.1-2003, ANSI Z87.1-2003)
- Boot Covers (as needed)
- Hearing Protection (as needed)
- High visibility clothing (shirt/vest)
- Hand Protection (e.g., minimum cut resistance meeting ANSI 105-2000 Level 2)

Note that jewelry shall be removed or appropriately secured to prevent it from becoming caught in rotating equipment or unexpectedly snagged on a fixed object. (e.g., wrist watches bracelets, rings, chains and necklaces, open earrings). Do not wear loose clothing and all shoulder length hair should be tied back.

Site specific PPE ensembles and materials are identified within task specific JSAs located within Appendix A, and any upgrades or downgrades of the level of protection (i.e., not specified in the JSA) must be approved by the PP and immediately communicated to all Roux personnel and subcontractors as applicable. PPE is used in accordance with manufacturer's recommendations.

### 7.5.1 Hearing Conservation

Hearing protection is made available when noise exposures equal or exceed an 8-hour time-weighted average sound level of 85 dBA. Hearing protection is required when the 8-hour time weighted average sound level  $\geq$  90 dBA. Where noise exposure meets or exceeds this level, noise is listed as a physical hazard in the JSA for the tasks/operation, and hearing protection is included as one of the control measures (PPE).

### 7.6 Monitoring

An air monitoring program is important to the safety of on- and off-Site personnel, and the surrounding area. A preliminary survey, to establish background conditions in the immediate sampling area, may be made prior to the initiation of Site work including, but not limited to, monitoring wind direction (e.g. wind socks) and approximate temperature during all invasive Site activities. This survey will be conducted with the appropriate pre-calibrated air monitoring instrument(s), as warranted by the field activity. Once this survey has been complete, any changes in the type of PPE will be determined and relayed to those working onsite.

Work zone air monitoring will be performed to verify that the proper level of PPE is used, and to determine if increased protection or work stoppage is required. The following equipment shall be used to monitor conditions:

- A Photoionization Detector (PID) with a lamp energy of 10.6 eV will be used to provide direct readings of organic vapor concentrations during intrusive activities to determine that personnel protection is adequate. Concentrations shall be recorded during intrusive activities with the potential to encounter contaminant vapors.
- In accordance with the Site Management Plan (SMP), Community Air Monitoring is not required during future excavation for redevelopment at the Site. If unknown or unexpected contaminated media identified, including grossly contaminated soil or groundwater, NYSDEC will be notified and the CAMP may be implemented, if deemed appropriate. The CAMP is included in Appendix H of this HASP and includes action levels.

Personal exposure monitoring utilizing activated charcoal tubes may be considered based on whether or not the area sample results are at or above half of the PEL. The decision to perform the monitoring will be made by, and under the control of, the CHSM.

Below are monitoring action levels for Site-specific chemicals of concern. In the event that PID readings above the thresholds identified below are sustained for 5 minutes in the breathing zone, worker protection will require upgrading following notification to the OHSM and applicable parties (e.g., client, board of health, regulators, etc.).

#### 7.6.1 Action Levels for Air Monitoring

PPE can remain at Level D if breathing zone VOC concentrations are less than 5 ppm and benzene is non-detect. Personnel are required to evacuate the Site when breathing zone VOC readings exceed 25 ppm.

The following tables include summaries of the air monitoring, work practices, and action levels for the expected contaminants. The action levels to initiate testing with colorimetric tubes for airborne volatiles is 1 ppm (PID reading) and is based on the Permissible Exposure Limit (PEL) for benzene (1 ppm). The colorimetric tubes are used to confirm the presence or absence of specific constituents, and they do not provide a measured concentration.

Air Monitoring Summary and Action Levels Organic Vapors	
PID Reading in Breathing Zone (ppm) <sup>1</sup>	Action
0-1 ppm above background <sup>2</sup>	Continue monitoring
1-5 ppm sustained 60 seconds	Continue monitoring, if applicable initiate additional collection of benzene using colorimetric tubes.
<5 ppm and no presence of benzene	Continue Monitoring, ventilate space
≥ 5 ppm - ≤ 25 ppm and no presence of benzene	Ventilate space until PID reads < 5 ppm. If < 25 ppm cannot be achieved, upgrade to Level C <sup>3</sup> .
≥ 25 ppm	Ventilate space and evacuate area.

<sup>1</sup> Based on relative response/sensitivity of PID to benzene.

<sup>2</sup> Background concentrations should be established at the beginning of each work day. It may be necessary to re-establish background concentrations and ambient conditions vary through the day.

<sup>3</sup> Measured air concentrations of known organic vapors will be reduced by the respirator to one half of the PEL or lower, and the individual and combined compound concentrations shall be within the service limit of the respirator cartridge.

Air Monitoring Summary and Action Levels Oxygen	
O <sub>2</sub> Reading in Breathing Zone (%) <sup>1</sup>	Action
20.9% O <sub>2</sub>	Oxygen level normal
< 19.5% O <sub>2</sub>	Oxygen deficient Interrupt task/Evacuate area
>23.5% O <sub>2</sub>	Oxygen enriched Interrupt task/Evacuate area

1. Action levels based on USEPA Standard Operating Safety Guides; Table 5-1, Atmospheric Hazard Action Guidelines may be further restricted based on the CHSM's professional judgment and experience.

Air Monitoring Summary and Action Levels Carbon Monoxide	
CO Reading in Breathing Zone (ppm) <sup>1</sup>	Action
<25 ppm	Inspect exhaust system for leaks or other sources of CO. Monitor initially and every 15 minutes during use of CO-generating equipment

Air Monitoring Summary and Action Levels Carbon Monoxide	
CO Reading in Breathing Zone (ppm) <sup>1</sup>	Action
25-50 ppm	Ventilate area. Monitor continuously and record measurements. Contact PM.
>50 ppm	Cease Field Operations. Ventilate area.

1. Based upon the American Conference of Governmental Industrial Hygienists (ACGIH) Threshold Limit Value (TLV) of 25 ppm as an 8-hour time weighted average (TWA) and OSHA's Permissible Exposure Limit (PEL) of 50 ppm as an 8-hour TWA concentration.

Air Monitoring Summary and Action Levels Combustible Gases	
Lower Explosive Limit (LEL) Reading	Action
< 4% LEL (<2,000 ppm)	Site activities will continue with normal monitoring
4% – 20% LEL (2,000 – 10,000 ppm)	Stop work until levels dissipate to <4% LEL
> 20% LEL (>10,000 ppm)	Potential explosion hazard. Halt all site activities, research source of release, aerate work area, suppress source

Air Monitoring Summary and Action Levels Hydrogen Sulfide	
Hydrogen Sulfide (H <sub>2</sub> S) Reading	Action
<10 ppm	Site activities will continue with normal monitoring
>10 ppm	Stop work until levels dissipate to <10 ppm; use mechanical ventilation if possible
Cannot use air purifying respirators for H <sub>2</sub> S because of olfactory fatigue	

## 7.6.2 Air Monitoring Equipment and Calibration

A PID calibrated to an appropriate calibration mixture will be used to detect organic vapors in and around the work areas. Monitoring will be conducted in and around all work areas and at the workers breathing zone before activities commence to establish a background level, then at 15-minute intervals throughout the day. All equipment will be calibrated according to the manufacturer's recommendation. A calibration log will be maintained and will include the name of the person who performed the calibration, the date and time

calibrated, and the instrument reading at the time of calibration. A manual bellows pump or equivalent with colorimetric tubes for formaldehyde will be utilized to determine the course of action related to upgrading or downgrading the level of respiratory protection, as applicable.

If air monitoring data indicate safe levels of potentially harmful constituents at consistent intervals (5-minute intervals), then monitoring can be conducted less frequently (every 30 minutes). This determination will be made by the onsite SHSO. Monitoring data, including background readings and calibration records, will be documented. Work to be performed onsite will conform to Roux Associates' Standard Operating Procedures (SOPs). Conformance with these guidelines as well as the guidelines described in this HASP will aid in mitigating the physical and chemical hazards mentioned throughout this HASP.

## **7.7 Tailgate Safety Meetings**

A designated Site worker will provide daily safety briefings (e.g., tailgate meetings) including, but not limited to, the following scenarios:

- When new operations are to be conducted;
- Whenever changes in work practices must be implemented; and
- When new conditions are identified and/or information becomes available.

Daily safety briefings shall be recorded on the Roux Daily Tailgate Health and Safety Meeting Log/Daily Site Safety Checklist, and all completed forms will become a part of the project file.

## **7.8 Spill Containment**

Spill containment equipment and procedures should, at a minimum, meet the requirements of the facility's Spill Prevention, Control and Countermeasure Plan, if applicable. Otherwise, spill containment equipment and procedures must be considered depending on the task including, but not limited to, chemical/product transfer points and handling.

### **7.8.1 Initial Spill Notification and Response**

Any worker who discovers a hazardous substance spill will immediately notify Lauren Dolginko, Roux PM. The worker will, to his/her best ability, report the hazardous substance involved, the location of the spill, the estimated quantity of material spilled, the direction/flow of the spill material, related fire/explosion incidents, and any associated injuries without compromising their own safety.

### **7.8.2 Spill Evaluation and Response**

Lauren Dolginko, Roux PM is responsible for evaluating spills and determining the appropriate response. When this evaluation is being made, the spill area will be isolated and demarcated to the extent possible. If necessary to protect nearby community members, notification of the appropriate authorities is made by the PM as appropriate. Onsite response is limited to small spills (e.g., <10 gallons), large spills require external emergency responders who will be contacted by the SHSO.

## **7.9 Decontamination**

The decontamination section of the HASP describes how personnel and equipment are decontaminated when they leave the Exclusion Zone. This section also describes how residual waste from decontamination

processes is disposed. The site decontamination procedures are designed to achieve an orderly, controlled removal or neutralization of contaminants that may accumulate on personnel or equipment. These procedures minimize worker contact with contaminants and protect against the transfer of contaminants to clean areas of the site and off-site. They also extend the useful life of PPE by reducing the amount of time that contaminants contact and can permeate PPE surfaces. Decontamination is facilitated within the contamination reduction zone at this site.

### **7.9.1 Decontamination Procedures for Personnel and PPE**

The following are general decontamination procedures established and implemented at this site.

1. Decontamination is required for all workers exiting a contaminated area. Personnel may re-enter the Support Zone only after undergoing the decontamination procedures described below in the next section.
2. Protective clothing is decontaminated, cleaned, laundered, maintained and/or replaced as needed to ensure its effectiveness.
3. PPE used at this site that requires maintenance or parts replacement is decontaminated prior to repairs or
4. PPE used at this site is decontaminated or prepared for disposal on the premises. Personnel who handle contaminated equipment have been trained in the proper means to do so to avoid hazardous exposure.
5. This site uses an off-site laundry for decontamination of PPE. The site has informed that facility of the hazards associated with contaminated PPE from this site.
6. The site requires and trains workers that if their permeable clothing is splashed or becomes wetted with a hazardous substance, they will immediately exit the work zone, perform applicable decontamination procedures, shower, and change into uncontaminated clothing.
7. Procedures for disposal of decontamination waste meet applicable local, State, and Federal regulations.

### **7.9.2 Decontamination Procedures for Equipment**

All tools, equipment, and machinery from the Exclusion Zone or CRZ are decontaminated in the CRZ prior to removal to the Support Zone. Equipment decontamination procedures are designed to minimize the potential for hazardous skin or inhalation exposure and to avoid cross-contamination and chemical incompatibilities.

General Equipment Decontamination Procedures:

1. Decontamination is required for all equipment exiting a contaminated area. Equipment may re-enter the Support Zone only after undergoing the equipment decontamination procedures.
2. Vehicles that travel regularly between the contaminated and clean areas of the site are carefully decontaminated each time they exit the Exclusion Zone and the effectiveness of that decontamination is monitored to reduce the likelihood that contamination will be spread to other parts of the site.
3. Particular attention is given to decontaminating tires, scoops, and other parts of heavy equipment that are directly exposed to contaminants and contaminated soil.

The following items may be used to decontaminate equipment:

- Fresh water rinse;



- Non-phosphorus detergent wash;
- Distilled water rinse;
- Acetone rinse;
- Distilled water rinse; and
- A steam cleaner or pressure washer (heavy equipment only)

### 7.9.3 Monitoring the Effectiveness of Decontamination Procedures

Visual examination and sampling are used to evaluate the effectiveness of decontamination procedures. Visual examination is used to ensure that procedures are implemented as described and that they appear to control the spread of contaminants under changing site conditions. Visual examination is also used to inspect for signs of residual contamination or for contaminant permeation of PPE.

Personnel who work in contaminated areas of the site, either the Contamination Reduction Zone (CRZ) or the Exclusion Zone, are trained in the principles and practices of decontamination described in this section of the HASP and in related SOPs. If site procedures are changed as a result of inspection and monitoring, all affected employees are notified of these changes.

## 7.10 Confined Space Entry

Confined space entry will not be performed at the Site.

The following is a list of the safety requirements for confined space entry at the Site:

- **ROUX PERSONNEL ARE NOT AUTHORIZED TO ENTER AN OSHA PERMIT REQUIRED CONFINED SPACE;**
- Currently the scope of work **DOES NOT** require personnel to enter permitted confined space for this project; and
- Any changes to the field activities that may necessitate confined space entry will be reported to the Project Principal and OHSM.

Confined space is defined as any space, depression, or enclosure that:

- Has limited opening for entry and egress;
- Is large enough for an employee to enter and perform assigned work; and
- Is not intended for continuous occupancy.

A permit required confined space is one that meets the definition of a confined space and has one or more of the following characteristics:

- May contain or produce life-threatening atmospheres due to oxygen deficiency the presence of toxic, flammable, or corrosive contaminants;
- Contains a material that has the potential for engulfment;
- Has an internal configuration that may cause an entrant to be trapped or asphyxiated by inwardly converging walls or by a floor that slopes downward and tapers to a smaller cross-section; and
- Contains any other serious safety or health hazards.

Although Roux personnel will not perform confined space entry, it is expected that subcontractors performing cleaning and mitigation and/or remedial measures activities may be required to enter structures that are considered to be a permit required confined space. Permitting of the confined space as well as hazard mitigation for entry will be completed by the subcontractor in accordance with 1910.146.

### **7.11 Client and Site-Specific**

In addition to the OSHA-specific procedures discussed above, there may be client and site-specific safety procedures that must be adhered to during the performance of remedial activities at the Site.

### **7.12 Unusual or Significant Risks**

Field activities that appear to have unusual or significant risks that cannot be adequately managed with existing risk tools such as LPS, HASPs, traffic safety plans, work permits, design and O&M practices, equipment HAZOPS or other safety tools must be referred to the CHSM to help with the assessment and management of the associated potential safety risks. Examples include the use of explosives for demolition, use of firearms to control wildlife, rappelling, demolition over water, etc.

### **7.13 Activity-Specific**

In addition to the general hazards discussed above, there are activity-specific hazards associated with each work activity planned for the Site. An activity-specific JSA has been completed for each of the activities planned for the Site. JSAs are provided in Appendix A. In the event that new work activities or tasks are planned, JSAs will be developed and implemented prior to performing the new activities. In the absence of a JSA, the personnel performing work must prepare a field JSA and receive clearance from a designated competent safety official prior to performing any task with significant risk. In emergency situations where time is critical SPSAs will be utilized to identify the task, associated hazards and mitigative actions to take. For lower risk activities (as deemed by the discretion of a Competent Person) where a JSA is determined to not be needed, the individual(s) conducting the activities must perform SPSAs prior to and during the work.

#### **7.13.1 Electrical and Other Utility Assessment and Accommodations**

Roux shall perform a site walk to identify any potential overhead electrical or utility lines. All applicable guidelines will be followed in the vicinity of overhead power and utility lines (see Section 7.13.3 below).

Prior to the start of work onsite, onsite contractors marked out and removed any potential underground utility lines. Utility lines at the Site have not been of concern during the redevelopment thus far.

Roux has also reviewed all available Site maps showing buried utility lines to identify potential hazards, which revealed that no underground hazards are known to exist in the vicinity of the areas of the Site pertinent to this HASP.

#### **7.13.2 Subsurface Work**

Subsurface work activities will require adherence to Roux's Corporate Subsurface Utility Clearance Management program found within Appendix D.

### 7.13.2.1 Excavations and Trenching

All trenching and excavation work activities contracted by Roux shall comply with 29 CFR 1926.651-652 Subpart P. Additionally, for trenches greater than 4 feet deep, where employees will enter, the trench needs to have a stairway or ladder or other safe means of egress. Where employees will enter trenches greater than 5 feet deep, the trench must have some type of protective system or sloped appropriately to prevent cave-ins.

The SHSO will be present onsite during all Roux contracted excavation and backfill operations and will supplement health and safety monitoring conducted by Subcontractor air quality screening to ensure that appropriate levels of protection and safety procedures are utilized. The proximity of chemical, water, sewer, and electrical lines will be identified by Roux and/or their subcontractor before any subsurface activity or sampling is attempted.

The following safe work practices will be implemented during this task.

- The proximity of chemical, water, sewer, and electrical lines will be identified by a facility representative prior to beginning any subsurface activity.
- While earthmoving, stay out of the excavator's delineated heavy equipment exclusion zone and away from the excavation sides, where there is potential for cave in (within excavations that are 6 feet or more in depth, a delineated perimeter 6 feet away from the excavated edge is required).

#### Maximum Allowable Slopes

Soil or Rock Type	Maximum Allowable Slopes (H:V) <sup>1</sup> for Excavations Less Than 20 Feet Deep <sup>3</sup>
Stable Rock	Vertical (90°)
Type A <sup>2</sup>	<sup>3</sup> / <sub>4</sub> : 1 (53°)
Type B	1 : 1 (45°)
Type C	1 1/2 : 1 (34°)

OSHA (29 CFR 1926.652, Subpart P, Appendices A and B)

#### Notes:

- <sup>1</sup> Numbers shown in parentheses next to maximum allowable slopes are angles expressed in degrees from the horizontal. Angles have been rounded off.
- <sup>2</sup> A short-term maximum allowable slope of 1/2H : 1V (63°) is allowed in excavations in Type A soil that are 12 feet (3.67 meters) or less in depth. Short-term maximum allowable slopes for excavations greater than 12 feet (3.67 meters) in depth shall be 3/4H : 1V (53°).
- <sup>3</sup> Sloping or benching for excavations greater than 20 feet deep shall be designed and stamped by a registered professional engineer.

Proper stockpiling (i.e., 2 feet minimum distance from the excavation edge), containment, transport, storage, and disposal practices will be utilized and is dependent upon the potential type and amount of waste generated during operations. The location of safety equipment and evacuation procedures will be established prior to initiation of operations according to this HASP.

### 7.13.3 Heavy Equipment

Use of heavy equipment at the Site will require adherence to Roux's Corporate Heavy Equipment Exclusion Zone Management Program found within Appendix E. Additionally, operation of the drill rig/other heavy

equipment will maintain clearances from overhead power lines in accordance with OSHA 29 CFR1926.1408 Table A Minimum Clearance Distances provided below.

**Minimum Required Clearances for Energized Overhead Power Lines**

Nominal System Voltage of Power Line (K V)	Minimum Required Clearance (feet)
0-50	10
51-100	12
101-200	15
201-300	20
301-500	25
501-750	35
751-1000	45

1 kilovolt (KV) = 1,000 volts

## 7.14 Heat Stress

The National Oceanic and Atmospheric Administration records average minimum/maximum temperatures of 106 degrees Fahrenheit during the year in Bronx County , New York.

### 7.14.1 Heat Stress

Heat stress is a significant potential hazard and can be associated with heavy physical activity and/or the use of personal protective equipment in hot weather environments. Heat cramps are brought on by prolonged exposure to heat. As an individual sweats, water and salts are lost by the body resulting in painful muscle cramps. The signs and symptoms of heat stress are as follows:

- Severe muscle cramps, usually in the legs and abdomen;
- Exhaustion, often to the point of collapse; and
- Dizziness or periods of faintness.

First aid treatment includes, but is not limited to, shade, rest, and fluid replacement. Typically, the individual should recover within one-half hour while being monitored constantly. If the individual has not improved substantially within 30 minutes and the body temperature has not decreased, the individual should be transported to a hospital for medical attention.

### 7.14.2 Heat Exhaustion

Heat exhaustion may occur in a healthy individual who has been exposed to excessive heat while working or exercising. The circulatory system of the individual fails as blood collects near the skin to rid the body of excess heat through transference. The signs and symptoms of heat exhaustion are as follows:

- Rapid and shallow breathing;
- Weak pulse;

- Cold and clammy skin with heavy perspiration;
- Skin appears pale;
- Fatigue and weakness;
- Dizziness; and
- Elevated body temperature.

First aid treatment includes, but is not limited to, cooling the victim, elevating the feet, and replacing fluids.

If the individual is not substantially improved within 30 minutes and the body temperature has not decreased, the individual should be transported to the hospital for medical attention.

### **7.14.3 Heat Stroke**

Heat stroke occurs when an individual is exposed to excessive heat and stops sweating. This condition is classified as a MEDICAL EMERGENCY requiring immediate cooling of the victim and transport to a medical facility. The signs and symptoms of heat stroke are as follows:

- Dry, hot red skin;
- Body temperature approaching or above 105 degrees F;
- Confusion, altered mental state, slurred speech;
- Seizures;
- Large (dilated) pupils; and
- Loss of consciousness – the individual may go into a coma.

First aid treatment requires immediate cooling and transportation to a medical facility. Heat stress is a significant hazard if any type of protective equipment (semi-permeable or impermeable) that prevents evaporative cooling is worn in hot weather environments.

### **7.15 Cold Stress**

Cold stress is a danger at low temperatures and when the wind-chill factor is low. Prevention of cold-related illnesses is a function of whole-body protection. Adequate insulating clothing must be used when the air temperature is below 60°F. A work/rest regimen will be initiated when ambient temperatures and protective clothing cause a stressful situation. In addition, reduced work periods followed by rest in a warm area may be necessary in extreme conditions. The signs and symptoms of cold stress include the following:

- Severe shivering;
- Abnormal behavior;
- Slowing;
- Weakness;
- Stumbling or repeated falling;
- Inability to walk;
- Collapse; and/or
- Unconsciousness.

First aid requires removing the victim from the cold environment and seeking medical attention immediately. Also, prevent further body heat loss by covering the victim lightly with blankets. Do not cover the victim's face. If the victim is still conscious, administer hot drinks and encourage activity such as walking, wrapped in a blanket.

## **7.16 COVID-19**

Measures for protecting workers from exposure to, and infection with, SARS-CoV-2, the virus that causes Coronavirus Disease 2019 (COVID-19), depend on the type of work being performed and exposure risk, including potential for interaction with people with suspected or confirmed COVID-19 and contamination of the work environment. Roux has performed an analysis of these risks based upon published government agency guidelines. Roux has developed health and safety guidance specific to COVID-19, which is provided as Appendix F. CDC's Face Covering Procedure is provided in Appendix G.

# 8. Field Team Review

Each person performing work at or visiting this site shall sign this section after site-specific training is completed and before being permitted to access the CRZ or Exclusion Zone.

I have read and understand this Site-Specific Health and Safety Plan. I will comply with the provision contained therein.

**Site/Project: The Peninsula Redevelopment Project**

Name & Company	Signature	Date

## 9. Approvals

By their signature, the undersigned certify that this HASP is approved and will be utilized at the Peninsula Redevelopment Project Site.

---

Site Health and Safety Officer

---

Date

*Kristina DeLuca*

---

November 2, 2020

---

Kristina DeLuca - Office Health and Safety Manager

---

Date

*Lauren Dolginko*

---

November 2, 2020

---

Lauren Dolginko – Project Manager

---

Date

*Frank Cherena*

---

November 2, 2020

---

Frank Cherena – Project Principal

---

Date



**Site-Specific Health and Safety Plan**  
***The Peninsula Redevelopment Project***  
***1221 Spofford Avenue, Bronx, New York***

---

**TABLE**

Toxicological, Physical, and Chemical Properties of Compounds  
Potentially Present at 1221 Spofford Avenue, Bronx, New York

**Table 1. Toxicological, Physical, and Chemical Properties of Compounds Potentially Present at 1221 Spofford Avenue, Bronx, New York**

Compound	CAS #	ACGIH TLV	NIOSH REL	OSHA PEL	IDLH	Routes of Exposure	Toxic Properties	Target Organs	Physical/Chemical Properties
1,1,1-Trichloroethane	71-55-6	TWA 350 ppm STEL 440 ppm C 440 ppm	C 350 ppm (1900 mg/m <sup>3</sup> ) [15-minute]	TWA 350 ppm (1900 mg/m <sup>3</sup> )	700 ppm	inhalation, ingestion, skin and/or eye contact	Irritation eyes, skin; headache, lassitude (weakness, exhaustion), central nervous system depression, poor equilibrium; dermatitis; cardiac arrhythmias; liver damage	Eyes, skin, central nervous system, cardiovascular system, liver	Colorless liquid with a mild, chloroform-like odor. BP: 165°F UEL: 12.5% LEL: 7.5%
1,1,2-Trichloroethane	79-00-5	TWA 10 ppm	Ca TWA 10 ppm (45 mg/m <sup>3</sup> ) [skin]	TWA 10 ppm (45 mg/m <sup>3</sup> ) [skin]	Ca [100 ppm]	inhalation, skin absorption, ingestion, skin and/or eye contact	Irritation eyes, nose; central nervous system depression; liver, kidney damage; dermatitis; [potential occupational carcinogen]	Eyes, respiratory system, central nervous system, liver, kidneys	Colorless liquid with a sweet, chloroform-like odor. BP: 237°F UEL: 15.5% LEL: 6%
1,1-Dichloroethane	75-34-3	TWA 100 ppm	TWA 100 ppm (400 mg/m <sup>3</sup> )	TWA 100 ppm (400 mg/m <sup>3</sup> )	3000 ppm	inhalation, ingestion, skin and/or eye contact	Irritation skin; central nervous system depression; liver, kidney, lung damage	Skin, liver, kidneys, lungs, central nervous system	Colorless, oily liquid with a chloroform-like odor. BP: 135°F F.L.P.: 2°F UEL: 11.4% LEL: 5.4%
1,1-Dichloroethene	75-35-4	TWA 5 ppm	Ca (lowest feasible concentration), TWA 1ppm		Ca [N.D.]	inhalation, skin absorption, ingestion, skin and/or eye contact	Irritation eyes, skin, throat; dizziness, headache, nausea, dyspnea (breathing difficulty); liver, kidney disturbance; pneumonitis; [potential occupational carcinogen]	Eyes, skin, respiratory system, central nervous system, liver, kidneys	Colorless liquid or gas (above 89°F) with a mild, sweet, chloroform-like odor. BP: 89°F F.L.P.: -2°F UEL: 15.5% LEL: 6.5% Class IA Flammable Liquid
1,2,4-Trimethylbenzene	95-63-6	None established	TWA 25 ppm (125mg/m <sup>3</sup> )	None established	N.D.	Inhalation; ingestion; skin and/or eye contact	Eye, skin, nose, and throat, resp syst irritation; bronchitis; hypochromic anemia; headache, drowsiness, weakness, dizziness, nausea, incoordination, vomit, confusion; chemical pneumonitis	Eyes, skin, resp sys, CNS, blood	Clear, colorless liquid with a distinctive, aromatic odor BP: 337°F F.L.P.: 112°F UEL: 6.4% LEL: 0.9% Class II Flammable liquid
1,2,4-Trimethylbenzene	95-63-6	TWA 25 ppm (125 mg TWA 25 ppm (125 mg/m <sup>3</sup> )		None established	N.D.	inhalation, ingestion, skin and/or eye contact	Irritation eyes, skin, nose, throat, respiratory system; bronchitis; hypochromic anemia; headache, drowsiness, fatigue, dizziness, nausea, incoordination; vomiting, confusion; chemical pneumonitis (aspiration liquid)	Eyes, skin, respiratory system, central nervous system, blood	Clear, colorless liquid with a distinctive, aromatic odor. BP: 337°F F.L.P.: 112°F UEL: 6.4% LEL: 0.9% Class II Flammable Liquid
1,2-Dichlorobenzene	95-50-1	TWA 25 ppm STEL 50 ppm	C 50 ppm (300 mg/m <sup>3</sup> )	C 50 ppm (300 mg/m <sup>3</sup> )	200 ppm	inhalation, skin absorption, ingestion, skin and/or eye contact	Irritation eyes, nose; liver, kidney damage; skin blisters	Eyes, skin, respiratory system, liver, kidneys	Colorless to pale-yellow liquid with a pleasant, aromatic odor. [herbicide] BP: 357°F F.L.P.: 151°F UEL: 9.2% LEL: 2.2% Class IIIA Combustible Liquid

**Table 1. Toxicological, Physical, and Chemical Properties of Compounds Potentially Present at 1221 Spofford Avenue, Bronx, New York**

Compound	CAS #	ACGIH TLV	NIOSH REL	OSHA PEL	IDLH	Routes of Exposure	Toxic Properties	Target Organs	Physical/Chemical Properties
1,2-Dichloroethane	107-06-2	TWA 10 ppm	Ca TWA 1 ppm (4 mg/m <sup>3</sup> ) STEL 2 ppm (8 mg/m <sup>3</sup> )	TWA 50 ppm C 100 ppm 200 ppm [5-minute maximum peak in any 3 hours]	Ca [50 ppm]	inhalation, ingestion, skin absorption, skin and/or eye contact	Irritation eyes, corneal opacity; central nervous system depression; nausea, vomiting; dermatitis; liver, kidney, cardiovascular system damage; [potential occupational carcinogen]	Eyes, skin, kidneys, liver, central nervous system, cardiovascular system	Colorless liquid with a pleasant, chloroform-like odor. [Note: Decomposes slowly, becomes acidic & darkens in color.] BP: 182°F F.P: 56°F UEL: 16% LEL: 6.2% Class IB Flammable Liquid
1,2-Dichloroethene (total)	540-59-0	TWA 200 ppm (790 m TWA 200 ppm (790 mg/m <sup>3</sup> )		TWA 200 ppm (790 mg/m <sup>3</sup> )	1000 ppm	inhalation, ingestion, skin and/or eye contact	Irritation eyes, respiratory system; central nervous system depression	Eyes, respiratory system, central nervous system	Colorless liquid (usually a mixture of the cis & trans isomers) with a slightly acrid, chloroform-like odor BP: 118-140°F F.P: 36-39°F UEL: 12.8% LEL: 5.6% Class IB Flammable Liquid
1,3,5-Trimethylbenzene	108-67-8	None established	TWA 25 ppm (125mg/m <sup>3</sup> )	None established	N.D.	Inhalation; ingestion; skin and/or eye contact	Eye, skin, nose, and throat, resp syst irritation; bronchitis; hypochromic anemia; headache, drowsiness, weakness, dizziness, nausea, incoordination, vomit, confusion; chemical pneumonitis	Eyes, skin, resp sys, CNS, blood	Clear, colorless liquid with a distinctive, aromatic odor BP: 329°F F.L.P: 122°F Class II Flammable liquid
1,3,5-Trimethylbenzene	108-67-8	TWA 25 ppm (125 mg TWA 25 ppm (125 mg/m <sup>3</sup> )		None established	N.D	inhalation, ingestion, skin and/or eye contact	Irritation eyes, skin, nose, throat, respiratory system; bronchitis; hypochromic anemia; headache, drowsiness, lassitude (weakness, exhaustion), dizziness, nausea, incoordination; vomiting, confusion; chemical pneumonitis (aspiration liquid)	Eyes, skin, respiratory system, central nervous system, blood	Clear, colorless liquid with a distinctive, aromatic odor. BP: 329°F F.L.P: 122°F Class II Flammable Liquid
1,4-Dichlorobenzene	106-46-7	TWA 10 ppm	Ca	TWA 75 ppm (450 mg/m <sup>3</sup> )	Ca [150 ppm]	inhalation, skin absorption, ingestion, skin and/or eye contact	Eye irritation, swelling periorbital (situated around the eye); profuse rhinitis; headache, anorexia, nausea, vomiting; weight loss, jaundice, cirrhosis; in animals: liver, kidney injury; [potential occupational carcinogen]	Liver, respiratory system, eyes, kidneys, skin	Colorless or white crystalline solid with a mothball-like odor. [insecticide] BP: 345°F F.L.P: 150°F LEL: 2.5% Combustible Solid
2,4-Dimethylphenol	105-67-9	None established	None established	None established	None established	inhalation, skin absorption, ingestion, skin and/or eye contact	Irritation eyes, skin, respiratory system, mouth, throat, stomach; dizziness, weakness, fatigue, nausea, headache; systemic damage; moderate to severe eye injury.	Skin, CVS, eyes, CNS	Clear, colorless liquid with a faint ether or chloroform-like odor BP: 178°F

**Table 1. Toxicological, Physical, and Chemical Properties of Compounds Potentially Present at 1221 Spofford Avenue, Bronx, New York**

Compound	CAS #	ACGIH TLV	NIOSH REL	OSHA PEL	IDLH	Routes of Exposure	Toxic Properties	Target Organs	Physical/Chemical Properties
2-Butanone (MEK)	78-93-3	TWA 200 ppm (590 mg/m <sup>3</sup> ) STEL 300 ppm (885 mg/m <sup>3</sup> )	TWA 200 ppm (590 mg/m <sup>3</sup> ) STEL 300 ppm (885 mg/m <sup>3</sup> )	TWA 200 ppm (590 mg/m <sup>3</sup> )	3000 ppm	inhalation, ingestion, skin and/or eye contact	Irritation eyes, skin, nose; headache; dizziness; vomiting; dermatitis	Eyes, skin, respiratory system, central nervous system	Colorless liquid with a moderately sharp, fragrant, mint- or acetone-like odor. BP: 175°F F.P.: 16°F UEL(200°F): 11.4% LEL(200°F): 1.4% Class IB Flammable Liquid
Acenaphthene	83-32-9	None established	None established	None established	None established	inhalation, ingestion, skin and/or eye contact	Irritation eyes, skin, respiratory system	Eyes, skin, respiratory system	Brown solid
Acetone	67-64-1	TWA 500 ppm STEL 50 ppm	TWA 250 ppm (590 mg/m <sup>3</sup> )	TWA 1000 ppm (2400 mg/m <sup>3</sup> )	2500 ppm [10%LEL]	inhalation, ingestion, skin and/or eye contact	Irritation eyes, nose, throat; headache, dizziness, central nervous system depression; dermatitis	Eyes, skin, respiratory system, central nervous system	Colorless liquid with a fragrant, mint-like odor BP: 133°F F.P.: 0°F UEL: 12.8% LEL: 2.5% Class IB Flammable Liquid
Anthracene	65996-93-2	TWA 0.2 mg/m <sup>3</sup>	Ca TWA 0.1 mg/m <sup>3</sup> (cyclohexane-extractable fraction)	TWA 0.2 mg/m <sup>3</sup> (benzene-soluble fraction)	Ca [80 mg/m <sup>3</sup> ]	inhalation, skin and/or eye contact	Dermatitis, bronchitis, [potential occupational carcinogen]	respiratory system, skin, bladder, kidneys	Black or dark-brown amorphous residue. Combustible Solids
Antimony	7440-36-0	TWA 0.5 mg/m <sup>3</sup>	TWA 0.5 mg/m <sup>3</sup>	TWA 0.5 mg/m <sup>3</sup>	50 mg/m <sup>3</sup> (as Sb)	inhalation, ingestion, skin and/or eye contact	Irritation eyes, skin, nose, throat, mouth; cough; dizziness; headache; nausea, vomiting, diarrhea; stomach cramps; insomnia; anorexia; unable to smell properly	Eyes, skin, respiratory system, cardiovascular system	Silver-white, lustrous, hard, brittle solid; scale-like crystals; or a dark-gray, lustrous powder. BP: 2975°F
Arsenic (inorganic)	7440-38-2 (metal)	TWA 0.01 mg/m <sup>3</sup>	Ca C 0.002 mg/m <sup>3</sup> [15-min]	TWA 0.010 mg/m <sup>3</sup>	Ca [5 mg/m <sup>3</sup> (as As)]	Inhalation; ingestion; skin absorption; skin and/or eye contact	Ulceration of nasal septum, dermatitis, GI disturbances, peripheral neuropathy, resp irritation, hyperpigmentation of skin, [potential occupational carcinogen]	Liver, kidneys, skin, lungs, lymphatic sys	Metal: silver-gray or tin-white, brittle, odorless solid BP: sublimates
Asbestos	1332-21-4	TWA 0.1 f/cc	Ca 100,000 fibers/m <sup>3</sup>	TWA 0.1 fiber/cm <sup>3</sup>	Ca [IDLH value has not been determined]	Inhalation; ingestion; skin and/or eye contact	Asbestosis (chronic exposure), dyspnea, interstitial fibrosis, restricted pulmonary function, finger clubbing, irritation eyes, [potential occupational carcinogen]	Respiratory system, eyes,	White or greenish (chrysotile), blue (crocidolite), or gray-green (amosite), fibrous, odorless solids. BP: decomposes
Asphalt fumes	8052-42-4	TWA 0.5 mg/m <sup>3</sup> (fumes)	Ca C 5 mg/m <sup>3</sup> [15 min]	None established	Ca [IDLH value has not been determined]	Skin absorption; inhalation; skin and/or eye contact	Irritation eyes, resp sys	Eyes, respiratory system	Black or dark brown cement-like substance Combustible solid
Barium	7440-39-3	TWA 0.5 mg/m <sup>3</sup>	None established	TWA 0.5 mg/m <sup>3</sup>	None established	Inhalation, ingestion, skin contact	Irritation skin, respiratory system, d	Skin, eyes, respiratory system	Yellow white powder BP: 1640 C
Benzene	71-43-2	TWA 0.5 ppm STEL 2.5 ppm	Ca TWA 0.1 ppm STEL 1 ppm	TWA 1 ppm STEL 5 ppm	Ca [500 ppm]	inhalation, skin absorption, ingestion, skin and/or eye contact	Irritation eyes, skin, nose, respiratory system; dizziness; headache, nausea, staggered gait; anorexia, lassitude (weakness, exhaustion); dermatitis; bone marrow depression; [potential occupational carcinogen]	Eyes, skin, respiratory system, blood, central nervous system, bone marrow	Colorless to light yellow liquid with an aromatic odor [Note: Solid below 42 °F] BP: 176°F F.P. = 12°F LEL: 1.2% UEL: 7.8% Class B Flammable liquid

**Table 1. Toxicological, Physical, and Chemical Properties of Compounds Potentially Present at 1221 Spofford Avenue, Bronx, New York**

Compound	CAS #	ACGIH TLV	NIOSH REL	OSHA PEL	IDLH	Routes of Exposure	Toxic Properties	Target Organs	Physical/Chemical Properties
Benzo[a]anthracene	56-55-3	None established	None established	None established	None established	Inhalation; ingestion; skin absorption; skin and/or eye contact	Irritation eyes, skin, respiratory system, CNS	Skin	Pale Yellow crystal, solid BP: 438 C
Benzo[a]pyrene	50-32-8	None established	TWA 0.1 mg/m3	TWA 0.2 mg/m3	None established	Inhalation; ingestion; skin absorption; skin and/or eye contact	POISON. This material is an experimental carcinogen, mutagen, tumorigen, neoplastigen and teratogen. It is a probable carcinogen in humans and a known human mutagen. IARC Group 2A carcinogen. It is believed to cause bladder, skin and lung cancer. Exposure to it may damage the developing foetus. May cause reproductive damage. Skin, respiratory and eye irritant or burns.	Skin, eye, bladder, lung, reproductive	Yellow crystals or powder [found in cigarette smoke, coal tar, fuel exhaust gas and in many other sources] BP: 495 C
Benzo[b]fluoranthene	205-99-2	None established	TWA 0.1 mg/m3	TWA 0.2 mg/m3	None established	Inhalation; ingestion; skin and/or eye contact	No data were identified on the toxicity of benzo[b]fluoranthene to humans. Based on results of studies in animals, IARC concluded that benzo[b]fluoranthene is possibly carcinogenic to humans	Respiratory system, skin, bladder, kidneys	Off-white to tan powder
Benzo[k]fluoranthene	207-08-9	None established	None established	None established	None established	inhalation, skin absorption, ingestion, skin and/or eye contact	Irritation eyes, skin, respiratory tract, gastrointestinal; fatal if swallowed, inhaled, absorbed through the skin; vomiting, nausea, diarrhea	Lungs, respiratory system	Yellow crystals BP: 480 C
Beryllium	7440-41-7 (metal)	TWA 0.002 mg/m <sup>3</sup>	Ca C 0.0005 mg/m <sup>3</sup>	TWA 0.002 mg/m <sup>3</sup> C 0.005 mg/m <sup>3</sup> (30 minutes) with a maximum peak of 0.025 mg/m <sup>3</sup>	Ca [4 mg/m <sup>3</sup> (as Be)]	inhalation, skin and/or eye contact	Berylliosis (chronic exposure): anorexia, weight loss, lassitude (weakness, exhaustion), chest pain, cough, clubbing of fingers, cyanosis, pulmonary insufficiency; irritation eyes; dermatitis; [potential occupational carcinogen]	Eyes, skin, respiratory system	Metal: A hard, brittle, gray-white solid. BP: 4532°F
Bis(2-ethylhexyl) phthalate	117-81-7	TWA 5 mg/m <sup>3</sup>	TWA 5 mg/m <sup>3</sup> STEL 10 mg/m <sup>3</sup> (do not exceed during any 15-minute work period)	TWA 5 mg/m <sup>3</sup>	None established	inhalation, skin and/or eye contact	Irritation eyes, skin, nose, throat; affect the nervous system and liver; damage to male reproductive glands	Eyes, skin, nose, respiratory system, nervous system, reproductive system, liver	Colorless to light colored, thick liquid with slight odor
Butane	106-97-8	TWA 1000 ppm	TWA 800 ppm (1900 mg/m <sup>3</sup> )	None established	None established	inhalation, skin and/or eye contact (liquid)	Drowsiness, narcosis, asphyxia; liquid: frostbite	central nervous system	Colorless gas with a gasoline-like or natural gas odor. BP: 31°F UEL: 8.4% LEL: 1.6% Flammable Gas

**Table 1. Toxicological, Physical, and Chemical Properties of Compounds Potentially Present at 1221 Spofford Avenue, Bronx, New York**

Compound	CAS #	ACGIH TLV	NIOSH REL	OSHA PEL	IDLH	Routes of Exposure	Toxic Properties	Target Organs	Physical/Chemical Properties
Cadmium	7440-43-9 (metal)	TWA 0.01 mg/m <sup>3</sup>	Ca	TWA 0.005 mg/m <sup>3</sup>	Ca [9 mg/m <sup>3</sup> (as Cd)]	inhalation, ingestion	Pulmonary edema, dyspnea (breathing difficulty), cough, chest tightness, substernal (occurring beneath the sternum) pain; headache; chills, muscle aches; nausea, vomiting, diarrhea; anosmia (loss of the sense of smell), emphysema, proteinuria, mild anemia; [potential occupational carcinogen]	respiratory system, kidneys, prostate, blood	Metal: Silver-white, blue-tinged lustrous, odorless solid. BP: 1409°F
Carbon Disulfide	75-15-0	TWA 1 ppm	TWA 1 ppm (3 mg/m <sup>3</sup> ) STEL 10 ppm (30 mg/m <sup>3</sup> ) [skin]	TWA 20 ppm C 30 ppm 100 ppm (30-minute maximum peak)	500 ppm	inhalation, skin absorption, ingestion, skin and/or eye contact	Dizziness, headache, poor sleep, lassitude (weakness, exhaustion), anxiety, anorexia, weight loss; psychosis; polyneuropathy; Parkinson-like syndrome; ocular changes; coronary heart disease; gastritis; kidney, liver injury; eye, skin burns; dermatitis; reproductive effects	central nervous system, peripheral nervous system, cardiovascular system, eyes, kidneys, liver, skin, reproductive system	Colorless to faint-yellow liquid with a sweet ether-like odor. BP: 116°F F.P.: -22°F UEL: 50.0% LEL: 1.3% Class IB Flammable Liquid
Chlorobenzene	108-90-7	TWA 10 ppm	None established	TWA 75 ppm (350 mg/m <sup>3</sup> )	1000 ppm	inhalation, ingestion, skin and/or eye contact	Irritation eyes, skin, nose; drowsiness, incoordination; central nervous system depression; in animals: liver, lung, kidney injury	Eyes, skin, respiratory system, central nervous system, liver	Colorless liquid with an almond-like odor BP: 270°F F.P.: 82°F UEL: 9.6% LEL: 1.3%
Chloroethane	75-00-3	TWA 100ppm	Handle with caution in the workplace	TWA 1000 ppm (2600 mg/m <sup>3</sup> )	3800 ppm [10%LEL]	inhalation, skin absorption (liquid), ingestion (liquid), skin and/or eye contact	Incoordination, inebriation; abdominal cramps; cardiac arrhythmias, cardiac arrest; liver, kidney damage	Liver, kidneys, respiratory system, cardiovascular system, central nervous system	Colorless gas or liquid (below 54°F) with a pungent, ether-like odor. BP: 54°F F.P.: NA (Gas) -58°F (Liquid) UEL: 15.4% LEL: 3.8% Flammable Gas
Chloroform	67-66-3	TWA 10 ppm	Ca STEL 2 ppm (9.78 mg/m <sup>3</sup> ) [60-minute]	C 50 ppm (240 mg/m <sup>3</sup> )	Ca [500 ppm]	inhalation, skin absorption, ingestion, skin and/or eye contact	Irritation eyes, skin; dizziness, mental dullness, nausea, confusion; headache, lassitude (weakness, exhaustion); anesthesia; enlarged liver; [potential occupational carcinogen]	Liver, kidneys, heart, eyes, skin, central nervous system	Colorless liquid with a pleasant odor BP: 143°F
Chromium	7440-47-3	TWA 0.5 mg/m <sup>3</sup> (metal and Cr III compounds) TWA 0.05 mg/m <sup>3</sup> (water-soluble Cr IV compounds) TWA 0.01 mg/m <sup>3</sup> (insoluble Cr IV compounds)	TWA 0.5 mg/m <sup>3</sup>	TWA 1 mg/m <sup>3</sup>	250 mg/m <sup>3</sup> (as Cr)	inhalation, ingestion, skin and/or eye contact	Irritation eyes, skin; lung fibrosis (histologic)	Eyes, skin, respiratory system	Blue-white to steel-gray, lustrous, brittle, hard, odorless solid. BP: 4788°F
Chrysene; Phenanthrene; Pyrene; Coal tar pitch volatiles	65996-93-2	TWA 0.2 mg/m <sup>3</sup>	Ca TWA 0.1 mg/m <sup>3</sup> (cyclohexane-extractable fraction)	TWA 0.2 mg/m <sup>3</sup> (benzene-soluble fraction)	Ca [80 mg/m <sup>3</sup> ]	Inhalation, skin and/or eye contact	Dermatitis, bronchitis, [potential occupational carcinogen]	Respiratory system, skin, bladder, kidneys	Black or dark-brown amorphous residue. Combustible Solids

**Table 1. Toxicological, Physical, and Chemical Properties of Compounds Potentially Present at 1221 Spofford Avenue, Bronx, New York**

Compound	CAS #	ACGIH TLV	NIOSH REL	OSHA PEL	IDLH	Routes of Exposure	Toxic Properties	Target Organs	Physical/Chemical Properties
cis-1,2-Dichloroethene	158-59-2	TWA 200 ppm	TWA 200 ppm	TWA 200 ppm	None established	inhalation, skin absorption, ingestion	Harmful if swallowed, inhaled, or absorbed through skin. Irritant. Narcotic. Suspected carcinogen	Skin	Colorless liquid BP: 60 C F.P.: 4 C UEL: 12.8% LEL: 9.7 %
Copper	7440-50-8	TWA 0.2mg/m <sup>3</sup> (fume) 1 mg/m <sup>3</sup> (dusts and mists)	TWA 1 mg/m <sup>3</sup>	TWA 1 mg/m <sup>3</sup>	100 mg/m <sup>3</sup> (as Cu)	Inhalation, ingestion, skin and/or eye contact	Irritation eyes, respiratory system; cough, dyspnea (breathing difficulty), wheezing	Eyes, skin, respiratory system, liver, kidneys (increase(d) risk with Wilson's disease)	Noncombustible Solid in bulk form, but powdered form may ignite. BP: 4703°F
Dibenzo[a,h]anthracene	53-70-3	None established	None established	None established	None established	Inhalation, ingestion, skin and/or eye contact	Irritation eyes, skin	Eyes, skin; skin photosensitization.	Colorless crystalline powder BP: 524°C
Diesel Fuel #2	68476-34-6	None established	None established	Designated as an OSHA Select Carcinogen	None established	ingestion, skin and/or eye contact	Kidney damage; potential lung damage; suspected carcinogen; irritation of eyes, skin, respiratory tract; dizziness, headache, nausea; chemical pneumonitis (from aspiration of liquid); dry, red skin; irritant contact dermatitis; eye redness, pain.	Eyes, skin, kidneys	Clear yellow brown combustible liquid; floats on water; distinct diesel petroleum hydrocarbon odor. BP: 356-716°F F.L.P.: 154.4-165.2°F LEL: 0.6% UEL: 7.0%
Ethylbenzene	100-41-4	TWA 100 ppm STEL 125 ppm	TWA 100 ppm (435 mg/m <sup>3</sup> ) STEL 125 ppm (545 mg/m <sup>3</sup> )	TWA 100 ppm (435 mg/m <sup>3</sup> )	800 ppm [10%LEL]	inhalation, ingestion, skin and/or eye contact	Irritation eyes, skin, mucous membrane; headache; dermatitis; narcosis, coma	Eyes, skin, respiratory system, central nervous system	Colorless liquid with an aromatic odor. BP: 277°F F.L.P.: 55°F UEL: 6.7% LEL: 0.8% Class 1B Flammable Liquid
Fluoranthene	206-44-0	None established	None established	None established	None established	inhalation, skin absorption, ingestion, skin and/or eye contact	Irritation eyes, skin; possible burns; heart and liver injury, pulmonary edema, respiratory arrest, gastrointestinal disturbances.	Heart, liver, lungs.	Yellow needles.
Fluorene	86-73-7	None established	None established	None established	None established	inhalation, ingestion, skin and/or eye contact	Irritation skin, digestive tract	Skin	White crystals BP: 563°F
Fuel Oil #2	68476-30-2	TWA 100mg/m <sup>3</sup> (aerosol and vapor, as total hydrocarbons)	None established	None established	None established	inhalation, skin absorption, ingestion, skin and/or eye contact	Irritation eyes, skin; CNS effects; nausea, vomiting, headache, cramping, dizziness, weakness, loss of coordination, drowsiness; kidney, liver damage	Eyes, skin, CNS	Clear or yellow to red oily liquid, kerosene-like odor BP: 347 - 689 °F UEL:5-6% LEL: 0.7-1.0%
Gasoline	8006-61-9	TWA 300 ppm STEL 500 ppm	Carcinogen	None established	Ca [IDLH value has not been determined]	Skin absorption; inhalation; ingestion; skin and/or eye contact	Eyes and skin irritation, mucous membrane; dermatitis; headache; listlessness, blurred vision, dizziness, slurred speech, confusion, convulsions; chemical pneumonitis; possible liver, kidney damage [Potential occupational carcinogen]	Eyes, skin, respiratory system, CNS, Liver, Kidneys	Clear liquid with a characteristic odor, aromatic F.L.Pt = -45°F LEL = 1.4% UEL = 7.6% Class 1B Flammable Liquid

**Table 1. Toxicological, Physical, and Chemical Properties of Compounds Potentially Present at 1221 Spofford Avenue, Bronx, New York**

Compound	CAS #	ACGIH TLV	NIOSH REL	OSHA PEL	IDLH	Routes of Exposure	Toxic Properties	Target Organs	Physical/Chemical Properties
Hexachlorobutadiene	87-68-3	TWA 0.02 ppm	Ca TWA 0.02 ppm (0.24 mg/m <sup>3</sup> ) [skin]	None established	Ca [N.D.]	inhalation, skin absorption, ingestion, skin and/or eye contact	In animals: irritation eyes, skin, respiratory system; kidney damage; [potential occupational carcinogen]	Eyes, skin, respiratory system, kidneys	Clear, colorless liquid with a mild, turpentine-like odor. BP: 419°F
Hydrogen Sulfide	7783-06-4	TWA (1 ppm) STEL (5 ppm) (adopted values for which changes are proposed in the NIC)	C 10 ppm (15 mg/m <sup>3</sup> ) [10-minute]	C 20 ppm 50 ppm [10-minute maximum peak]	100 ppm	inhalation, skin and/or eye contact	Irritation eyes, respiratory system; apnea, coma, convulsions; conjunctivitis, eye pain, lacrimation (discharge of tears), photophobia (abnormal visual intolerance to light), corneal vesiculation; dizziness, headache, lassitude (weakness, exhaustion), irritability, insomnia; gastrointestinal disturbance; liquid: frostbite	Eyes, respiratory system, central nervous system	Colorless gas with a strong odor of rotten eggs. BP: -77°F UEL: 44.0% LEL: 4.0% Flammable Gas
Indeno[1,2,3-cd]pyrene	193-39-5	None established	None established	None established	None established	inhalation, skin absorption, ingestion, skin and/or eye contact	Irritation eyes, skin; possible human carcinogen (skin); weakness; affect liver, lung tissue, renal tissue; impairment of blood forming tissue	Skin	Fluorescent green-yellow crystalline solid BP: 536 C
Indeno[1,2,3-cd]pyrene	193-39-5	None established	None established	None established	None established	inhalation, skin absorption, ingestion, skin and/or eye contact	Irritation eyes, skin; possible human carcinogen (skin); weakness; affect liver, lung tissue, renal tissue; impairment of blood forming tissue	Skin	Yellowish crystal solid BP: 536 C
Isopropylbenzene	98-82-8	TWA 50 ppm	TWA 50 ppm (245 mg/m <sup>3</sup> ) [skin]	TWA 50 ppm (245 mg/m <sup>3</sup> ) [skin]	900 ppm [10%LEL]	inhalation, skin absorption, ingestion, skin and/or eye contact	Irritation eyes, skin, mucous membrane; dermatitis; headache, narcosis, coma	Eyes, skin, respiratory system, central nervous system	Colorless liquid with a sharp, penetrating, aromatic odor. BP: 306°F F.P.: 96°F UEL: 6.5% LEL: 0.9%
Kerosene	8008-20-6	TWA 200 mg/m <sup>3</sup>	TWA 100 mg/m <sup>3</sup>	None established	IDLH value has not been determined	inhalation, ingestion, skin and/or eye contact	Irritation eyes, skin, nose, throat; burning sensation in chest; headache, nausea, lassitude (weakness, exhaustion), restlessness, incoordination, confusion, drowsiness; vomiting, diarrhea; dermatitis; chemical pneumonitis (aspiration liquid)	Eyes, skin, respiratory system, central nervous system	Colorless to yellowish, oily liquid with a strong, characteristic odor. BP: 347-617°F F.P.: 100-162°F UEL: 5% LEL: 0.7% Class II Combustible Liquid
Lead	7439-92-1	TWA 0.05 mg/m <sup>3</sup>	TWA (8-hour) 0.050 mg/m <sup>3</sup>	TWA 0.050 mg/m <sup>3</sup>	100 mg/m <sup>3</sup> (as Pb)	inhalation, ingestion, skin and/or eye contact	Lassitude (weakness, exhaustion), insomnia; facial pallor; anorexia, weight loss, malnutrition; constipation, abdominal pain, colic; anemia; gingival lead line; tremor; paralysis wrist, ankles; encephalopathy; kidney disease; irritation eyes; hypertension	Eyes, gastrointestinal tract, central nervous system, kidneys, blood, gingival tissue	A heavy, ductile, soft, gray solid. BP: 3164°F Noncombustible Solid in bulk form



**Table 1. Toxicological, Physical, and Chemical Properties of Compounds Potentially Present at 1221 Spofford Avenue, Bronx, New York**

Compound	CAS #	ACGIH TLV	NIOSH REL	OSHA PEL	IDLH	Routes of Exposure	Toxic Properties	Target Organs	Physical/Chemical Properties
Manganese	7439-96-5 (metal)	TWA 0.2 mg/m <sup>3</sup>	TWA 1 mg/m <sup>3</sup> STEL 3 mg/m <sup>3</sup>	C 5 mg/m <sup>3</sup>	500 mg/m <sup>3</sup> (as Mn)	inhalation, ingestion	Manganism; asthenia, insomnia, mental confusion; metal fume fever: dry throat, cough, chest tightness, dyspnea (breathing difficulty), rales, flu-like fever; low-back pain; vomiting; malaise (vague feeling of discomfort); lassitude (weakness, exhaustion); kidney damage	respiratory system, central nervous system, blood, kidneys	A lustrous, brittle, silvery solid. BP: 3564°F
Mercury (organo) alkyl compounds (as Hg)	7439-97-6	TWA 0.01 mg/m <sup>3</sup> STEL 0.03 mg/m <sup>3</sup> [skin]	TWA 0.01 mg/m <sup>3</sup> STEL 0.03 mg/m <sup>3</sup> [skin]	TWA 0.01 mg/m <sup>3</sup> C 0.04 mg/m <sup>3</sup>	2 mg/m <sup>3</sup> (as Hg)	inhalation, skin absorption, ingestion, skin and/or eye contact	Paresthesia; ataxia, dysarthria; vision, hearing disturbance; spasticity, jerking limbs; dizziness; salivation; lacrimation (discharge of tears); nausea, vomiting, diarrhea, constipation; skin burns; emotional disturbance; kidney injury; possible teratogenic effects	Eyes, skin, central nervous system, peripheral nervous system, kidneys	Appearance and odor vary depending upon the specific (organo) alkyl mercury compound
Mercury compounds [except (organo) alkyls] (as Hg) Mercury	7439-97-6	TWA 0.025 mg/m <sup>3</sup> (elemental and inorganic forms)	Hg Vapor: TWA 0.05 mg/m <sup>3</sup> [skin] Other: C 0.1 mg/m <sup>3</sup> [skin]	TWA 0.1 mg/m <sup>3</sup>	10 mg/m <sup>3</sup> (as Hg)	inhalation, skin absorption, ingestion, skin and/or eye contact	Irritation eyes, skin; cough, chest pain, dyspnea (breathing difficulty), bronchitis, pneumonitis; tremor, insomnia, irritability, indecision, headache, lassitude (weakness, exhaustion); stomatitis, salivation; gastrointestinal disturbance, anorexia, weight loss; proteinuria	Eyes, skin, respiratory system, central nervous system, kidneys	Metal: Silver-white, heavy, odorless liquid. [Note: "Other" Hg compounds include all inorganic & aryl Hg compounds except (organo) alkyls.] BP: 674°F
Methyl tert-butyl ether (MTBE)	1634-04-4	TWA 50 ppm	No established REL	None established	None established	inhalation, skin absorption, ingestion, skin and/or eye contact	Irritation eyes, mucous membrane, respiratory; dizziness, nausea, headache, intoxication	Eyes, skin, mucous membrane, respiratory system, central nervous system	Colorless liquid BP: 55.2 C
Methylene Chloride	75-09-2	TWA 50 ppm, A3 - suspected human carcinogen	Ca	TWA 25 ppm STEL 125 ppm	Ca [2300 ppm]	inhalation, skin absorption, ingestion, skin and/or eye contact	Irritation eyes, skin; lassitude (weakness, exhaustion), drowsiness, dizziness; numbness, tingle limbs; nausea; [potential occupational carcinogen]	Eyes, skin, cardiovascular system, central nervous system	Colorless liquid with a chloroform-like odor BP: 104°F UEL: 23% LEL: 13%
Naphtha (coal tar)	8030-30-6	None established	TWA 100 ppm (400 mg/m <sup>3</sup> )	TWA 100 ppm (400 mg/m <sup>3</sup> )	1000 ppm [10%LEL]	inhalation, ingestion, skin and/or eye contact	Irritation eyes, skin, nose; dizziness, drowsiness; dermatitis; in animals: liver, kidney damage	Eyes, skin, respiratory system, central nervous system, liver, kidneys	Reddish-brown, mobile liquid with an aromatic odor BP: 320-428°F F.L.P.: 100-109°F Class II Combustible Liquid
Naphthalene	91-20-3	TWA 10 ppm STEL 15 ppm	TWA 10 ppm (50 mg/m <sup>3</sup> ) STEL 15 ppm (75 mg/m <sup>3</sup> )	TWA 10 ppm (50 mg/m <sup>3</sup> )	250 ppm	inhalation, skin absorption, ingestion, skin and/or eye contact	Irritation eyes; headache, confusion, excitement, malaise (vague feeling of discomfort); nausea, vomiting, abdominal pain; irritation bladder; profuse sweating; jaundice; hematuria (blood in the urine), renal shutdown; dermatitis, optical neuritis, corneal damage	Eyes, skin, blood, liver, kidneys, central nervous system	Colorless to brown solid with an odor of mothballs. BP: 424°F F.L.P.: 174°F UEL: 5.9% LEL: 0.9%

**Table 1. Toxicological, Physical, and Chemical Properties of Compounds Potentially Present at 1221 Spofford Avenue, Bronx, New York**

Compound	CAS #	ACGIH TLV	NIOSH REL	OSHA PEL	IDLH	Routes of Exposure	Toxic Properties	Target Organs	Physical/Chemical Properties
n-Butylbenzene	104-51-8	None established	None established	None established	None established	inhalation, skin absorption, ingestion, skin and/or eye contact	Irritation eyes, skin; CNS depression, lung damage; nausea, vomiting, headache, dizziness, weakness, loss of coordination, blurred vision, drowsiness, confusion, disorientation	Eyes, skin, respiratory system, central nervous system	Colorless liquid with a sweet odor BP: 183 C F.P.: 59 C UEL: 5.8% LEL: 0.8%
Nickel	7440-02-0 (Metal)	TWA 1.5 mg/m <sup>3</sup> (elemental) TWA 0.1 mg/m <sup>3</sup> (soluble inorganic compounds) TWA 0.2 mg/m <sup>3</sup> (insoluble inorganic compounds) TWA 0.1 mg/m <sup>3</sup> (Nickel subsulfide)	Ca TWA 0.015 mg/m <sup>3</sup>	TWA 1 mg/m <sup>3</sup>	Ca [10 mg/m <sup>3</sup> (as Ni)]	inhalation, ingestion, skin and/or eye contact	Sensitization dermatitis, allergic asthma, pneumonitis; [potential occupational carcinogen]	Nasal cavities, lungs, skin	Metal: Lustrous, silvery, odorless solid. BP: 5139°F
Nitrobenzene	98-95-3	TWA 1 ppm	TWA 1 ppm (5 mg/m <sup>3</sup> ) [skin]	TWA 1 ppm (5 mg/m <sup>3</sup> ) [skin]	200 ppm	inhalation, skin absorption, ingestion, skin and/or eye contact	Irritation eyes, skin; anoxia; dermatitis; anemia; methemoglobinemia; in animals: liver, kidney damage; testicular effects	Eyes, skin, blood, liver, kidneys, cardiovascular system, reproductive system	Yellow, oily liquid with a pungent odor like paste shoe polish. BP: 411°F F.P.: 190°F LEL(200°F): 1.8%
n-Propylbenzene	103-65-1	None established	None established	None established	None established	inhalation, ingestion, skin and/or eye contact	Harmful if swallowed, Irritation eyes, skin, digestive tract, respiratory tract, central nervous system	Eyes, skin, central nervous system, respiratory system	colorless or light yellow liquid BP: 159 C F.P.: 47 C UEL: 6% LEL: 0.8%
Petroleum hydrocarbons(Petroleum distillates)	8002-05-9	None established	TWA 350 mg/m <sup>3</sup> C 1800 mg/m <sup>3</sup> [15 min]	TWA 500 ppm (2000 mg/m <sup>3</sup> )	1,100 [10% LEL]	Inhalation; ingestion; skin and/or eye contact	Irritation eyes, skin, nose, throat; dizziness, drowsiness, headache, nausea; dried/cracked skin; chemical pneumonitis	CNS, eyes, respiratory system, skin	Colorless liquid with a gasoline or kerosene-like odor BP: 86-460°F Fl. Pt = -40 to -86°F UEL: 5.9% LEL: 1.1% Flammable liquid
Phenol	108-95-2	TWA 5 ppm	TWA 5 ppm (19 mg/m <sup>3</sup> ) C 15.6 ppm (60 mg/m <sup>3</sup> ) [15-minute] [skin]	TWA 5 ppm (19 mg/m <sup>3</sup> ) [skin]	250 ppm	inhalation, skin absorption, ingestion, skin and/or eye contact	Irritation eyes, nose, throat; anorexia, weight loss; lassitude (weakness, exhaustion), muscle ache, pain; dark urine; cyanosis; liver, kidney damage; skin burns; dermatitis; ochronosis; tremor, convulsions, twitching	Eyes, skin, respiratory system, liver, kidneys	Colorless to light-pink, crystalline solid with a sweet, acrid odor. BP: 359°F UEL: 8.6% LEL: 1.8%
p-Isopropyltoluene	99-87-6	None established	None established	None established	None established	inhalation, skin absorption, eye contact	Irritation skin	CNS, skin	Colorless, clear liquid, sweetish aromatic odor BP: 350.8°F Class III Flammable liquid
sec-Butylbenzene	135-98-8	None established	None established	None established	None established	inhalation, skin absorption, ingestion, skin and/or eye contact	Irritation eyes, skin, upper airway; central nervous system, headache, dizziness; gastrointestinal disturbance	Respiratory system, central nervous system, eyes, skin;	Colorless liquid BP: 344°F F.P.: 126 °F UEL: 6.9% LEL: 0.8% Combustible liquid

**Table 1. Toxicological, Physical, and Chemical Properties of Compounds Potentially Present at 1221 Spofford Avenue, Bronx, New York**

Compound	CAS #	ACGIH TLV	NIOSH REL	OSHA PEL	IDLH	Routes of Exposure	Toxic Properties	Target Organs	Physical/Chemical Properties
Selenium	7782-49-2	TWA 0.2 mg/m <sup>3</sup>	TWA 0.2 mg/m <sup>3</sup>	TWA 0.2 mg/m <sup>3</sup>	1 mg/m <sup>3</sup> (as Se)	inhalation, ingestion, skin and/or eye contact	Irritation eyes, skin, nose, throat; visual disturbance; headache; chills, fever; dyspnea (breathing difficulty), bronchitis; metallic taste, garlic breath, gastrointestinal disturbance; dermatitis; eye, skin burns; in animals: anemia; liver necrosis, cirrhosis; kidney, spleen damage	Eyes, skin, respiratory system, liver, kidneys, blood, spleen	Amorphous or crystalline, red to gray solid. [Note: Occurs as an impurity in most sulfide ores.] BP: 1265°F
Silver	7440-22-4 (metal)	TWA 0.1 mg/m <sup>3</sup> (metal, dust, fumes) TWA 0.01 mg/m <sup>3</sup> (Soluble compounds, as Ag)	TWA 0.01 mg/m <sup>3</sup>	TWA 0.01 mg/m <sup>3</sup>	10 mg/m <sup>3</sup> (as Ag)	inhalation, ingestion, skin and/or eye contact	Blue-gray eyes, nasal septum, throat, skin; irritation, ulceration skin; gastrointestinal disturbance	Nasal septum, skin, eyes	Metal: White, lustrous solid BP: 3632°F
Stop Oil	69029-75-0	None established	None established	None established	None established	Inhalation; ingestion	Irritation eyes, skin, gastrointestinal tract	Eyes, skin, gastrointestinal tract	Clear light to dark amber liquid, with mild hydrocarbon odor. BP: >500°F F.L.P.: 250°F
Sulfuric Acid	7664-93-9	TWA 0.2 mg/m <sup>3</sup>	TWA 1 mg/m <sup>3</sup>	TWA 1 mg/m <sup>3</sup>	15 mg/m <sup>3</sup>	inhalation, ingestion, skin and/or eye contact	Irritation eyes, skin, nose, throat; pulmonary edema, bronchitis; emphysema; conjunctivitis; stomatis; dental erosion; eye, skin burns; dermatitis	Eyes, skin, respiratory system, teeth	Colorless to dark-brown, oily, odorless liquid. BP: 554°F Noncombustible Liquid
tert-Butylbenzene	98-06-6	None established	None established	None established	None established	inhalation, skin absorption, ingestion,	Eye and respiratory irritant; CNS depression; liver or kidney damage	Respiratory system, central nervous system, eyes, liver, kidney	Colorless liquid with an aromatic odor BP: 168 - 169 C F.L.P.: 34 C UEL: 5.6 % LEL: 0.8 %
Tetrachloroethene	127-18-4	TWA 25 ppm STEL 100 ppm (STEL) listed as A3, animal carcinogen	Ca Minimize workplace exposure concentrations	TWA 100 ppm C 200 ppm (for 5 minutes in any 3-hour period), with a maximum peak of 300 ppm	Ca [150 ppm]	inhalation, skin absorption, ingestion, skin and/or eye contact	Irritation eyes, skin, nose, throat, respiratory system; nausea; flush face, neck; dizziness, incoordination; headache, drowsiness; skin erythema (skin redness); liver damage; [potential occupational carcinogen]	Eyes, skin, respiratory system, liver, kidneys, central nervous system	Colorless liquid with a mild, chloroform-like odor. BP: 250°F Noncombustible Liquid
Toluene	108-88-3	TWA 20 ppm	TWA 100 ppm (375 mg/m <sup>3</sup> ) STEL 150 ppm (560 mg/m <sup>3</sup> )	TWA 200 ppm C 300 ppm 500 ppm (10-minute maximum peak)	500 ppm	inhalation, skin absorption, ingestion, skin and/or eye contact	Irritation eyes, nose; lassitude (weakness, exhaustion), confusion, euphoria, dizziness, headache; dilated pupils, lacrimation (discharge of tears); anxiety, muscle fatigue, insomnia; paresthesia; dermatitis; liver, kidney damage	Eyes, skin, respiratory system, liver, kidneys	Colorless liquid with a sweet, pungent, benzene-like odor. BP: 232°F F.L.P.: 40°F UEL: 7.1% LEL: 1.1% Class IB Flammable Liquid
trans-1,2-Dichloroethene	156-60-5	TWA 200 ppm	None established	TWA 200 ppm STEL 250 ppm (skin)	None established	inhalation, skin absorption, ingestion, skin and/or eye contact	Narcotic. Irritation eyes, skin, respiratory tract, mucous membrane; CNS depression.	Respiratory tract, mucous membrane, eyes, skin, CNS	Colorless liquid with a fruity pleasant odor BP: 48°C F.L.P. 6C UEL: 12.8% LEL: 9.7%

**Table 1. Toxicological, Physical, and Chemical Properties of Compounds Potentially Present at 1221 Spofford Avenue, Bronx, New York**

Compound	CAS #	ACGIH TLV	NIOSH REL	OSHA PEL	IDLH	Routes of Exposure	Toxic Properties	Target Organs	Physical/Chemical Properties
Trichloroethene	79-01-6	TWA 10 ppm STEL 25 ppm	Ca	TWA 100 ppm C 200 ppm 300 ppm (5-minute maximum peak in any 2 hours)	Ca [1000 ppm]	inhalation, skin absorption, ingestion, skin and/or eye contact	Irritation eyes, skin; headache, visual disturbance, lassitude (weakness, exhaustion), dizziness, tremor, drowsiness, nausea, vomiting; dermatitis; cardiac arrhythmias, paresthesia; liver injury; [potential occupational carcinogen]	Eyes, skin, respiratory system, heart, liver, kidneys, central nervous system	Colorless liquid (unless dyed blue) with a chloroform-like odor. BP: 189°F UEL(77°F): 10.5% LEL(77°F): 8%
Vinyl Chloride	75-01-4	TWA 1 ppm	Carcinogen	TWA 1 ppm C 5 ppm [15-minute]	Ca [IDLH value has not been determined]	inhalation, skin, and/or eye contact (liquid)	Lassitude (weakness, exhaustion); abdominal pain, gastrointestinal bleeding; enlarged liver; pallor or cyanosis of extremities; liquid: frostbite; [potential occupational carcinogen]	Liver, central nervous system, blood, respiratory system, lymphatic system	Colorless gas or liquid (below 7°F) with a pleasant odor at high concentrations. BP: 7°F UEL: 33.0% LEL: 3.6% Flammable Gas
Xylene (m, o & p isomers)	108-38-3, 95-47-6, 106-42-3	TWA 100 ppm (435 mg/m <sup>3</sup> ) STEL 150 ppm	TWA 100 ppm (435 mg/m <sup>3</sup> )	TWA 100 ppm (435 mg/m <sup>3</sup> )	900 ppm	Skin absorption, inhalation, ingestion, skin, and/or eye contact	Irritation eyes, skin, nose, throat; dizziness, excitement, drowsiness, incoordination, staggering gait; corneal vacuolization; anorexia, nausea, vomiting, abdominal pain; dermatitis	Eyes, skin, respiratory system, central nervous system, gastrointestinal tract, blood, liver, kidneys	Colorless liquid with an aromatic odor BP: 282°F, 292°F, 281°F Fl. Pt. 82°F, 90°F, 81°F LEL: 1.1%, 0.9%, 1.1% UEL: 7.0%, 6.7%, 7.0% Class C Flammable Liquid
Zinc	7440-66-6	TWA 10 mg/m <sup>3</sup> (Inhalable fraction)	None established	TWA 10 mg/m <sup>3</sup> (for zinc oxide fume)	None established	skin and/or eye contact, inhalation, ingestion	Irritation eyes, skin, respiratory tract; gastrointestinal disturbances	Eyes, skin, respiratory system	Bluish gray solid BP: 1664.6°F Flammable

**Table 1. Toxicological, Physical, and Chemical Properties of Compounds Potentially Present at 1221 Spofford Avenue, Bronx, New York**

**References**

U.S. Department of Labor. 1990. OSHA Regulated Hazardous Substances, industrial Exposure and Control Technologies Government Institutes, Inc.  
Hawley's Condensed Chemical Dictionary, Sax, N. Van Nostrand and Reinhold Company, 11th Edition, 1987.  
Proctor, N.H., J.P. Hughes and M.L. Fischman, 1989. Chemical Hazards of the Workplace. Van Nostrand Reinhold. New York.  
Sax, N.I. and R.J. Lewis. 1989. Dangerous Properties of Industrial Materials. 7th Edition. Van Nostrand Reinhold. New York.  
Guide to Occupational Exposure Values. 2008. American Conference of Governmental Industrial Hygienists (ACGIH).  
NIOSH Pocket Guide to Chemical Hazards. 2005. Department of Health and Human Services, Centers for Disease Control and Prevention, National Institute for Occupational Safety and Health

**Abbreviations:**

ACGIH – American Conference of Governmental Industrial Hygienists.  
BP – boiling point at 1 atmosphere, °F  
C – Ceiling, is a concentration that should not be exceeded during and part of the working exposure.  
Ca - considered by NIOSH to be a potential occupational carcinogen  
CAS# Chemical Abstracts Service registry number which is unique for each chemical.  
Fl. Pt. – Flash point  
IDLH - Immediately Dangerous to Life and Health concentrations represent the maximum concentration from which, in the event of respirator failure, one could escape within 30 minutes without a respirator and without experiencing any escape-impairing or irreversible health effects.  
LEL – Lower explosive (flammable) limit in air, % by volume (at room temperature)  
mg/m<sup>3</sup> – Milligrams of substance per cubic meter of air  
NIOSH -National Institute for Occupational Safety and Health.  
OSHA – Occupational Safety and Health Administration  
PEL - OSHA Permissible Exposure Limit (usually) a time weighted average concentration that must not be exceeded during any 8 hour work shift of a 40 hr work week.  
ppm – parts per million  
REL – NIOSH Recommended Limit indicated a time weighted average concentration that must not be exceeded during any 10 hour work shift of a 40 hr work week  
STEL – Short-term exposure limit  
TLV -ACGIH Threshold Limit Values (usually 8 hour time weighted average concentrations).  
TWA – 8-hour, time-weighted average  
UEL – Upper explosive (flammable) limit in air, % by volume (at room temperature)

**Site-Specific Health and Safety Plan**  
***The Peninsula Redevelopment Project***  
***1221 Spofford Avenue, Bronx, New York***

---

**FIGURES**

1. Site Location Map
2. Site Plan
3. Directions to Bronx Lebanon Hospital Center
4. Directions to City MD

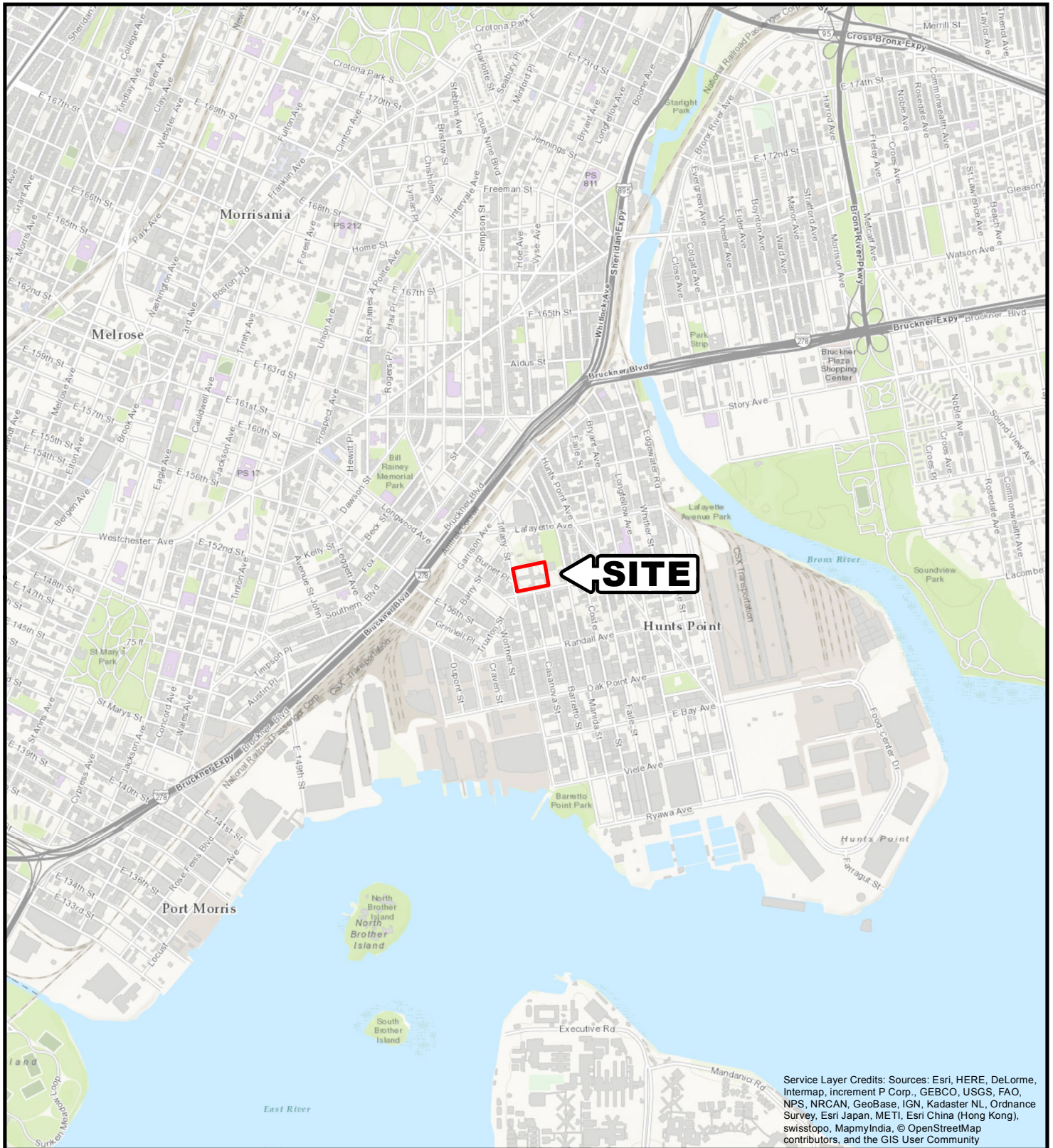

Service Layer Credits: Sources: Esri, HERE, DeLorme, Intermap, increment P Corp., GEBCO, USGS, FAO, NPS, NRCAN, GeoBase, IGN, Kadaster NL, Ordnance Survey, Esri Japan, METI, Esri China (Hong Kong), swisstopo, MapmyIndia, © OpenStreetMap contributors, and the GIS User Community

V:\GIS\Projects\2611\0002Y\104\2611.0002Y104.1.mxd

**QUADRANGLE LOCATION**

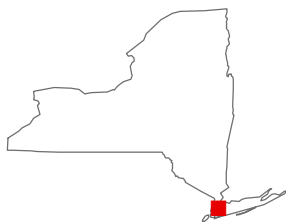

1,000 0 1,000 2,000 Feet

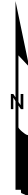

Title:

**SITE LOCATION MAP**

1221 SPOFFORD AVENUE  
BRONX, NEW YORK

Prepared For:

THE PENINSULA JV, LLC



Compiled by: J.P.G.	Date: 16JUN17	<b>FIGURE</b>  <b>1</b>
Prepared by: M.R.	Scale: AS SHOWN	
Project Mgr: J.P.G.	Project: 2611.0002Y000	
File: 2611.0002Y104.1.mxd		

V:\CAD\PROJECTS\2611Y\0002Y\108R\2611.0002Y108R.04.DWG

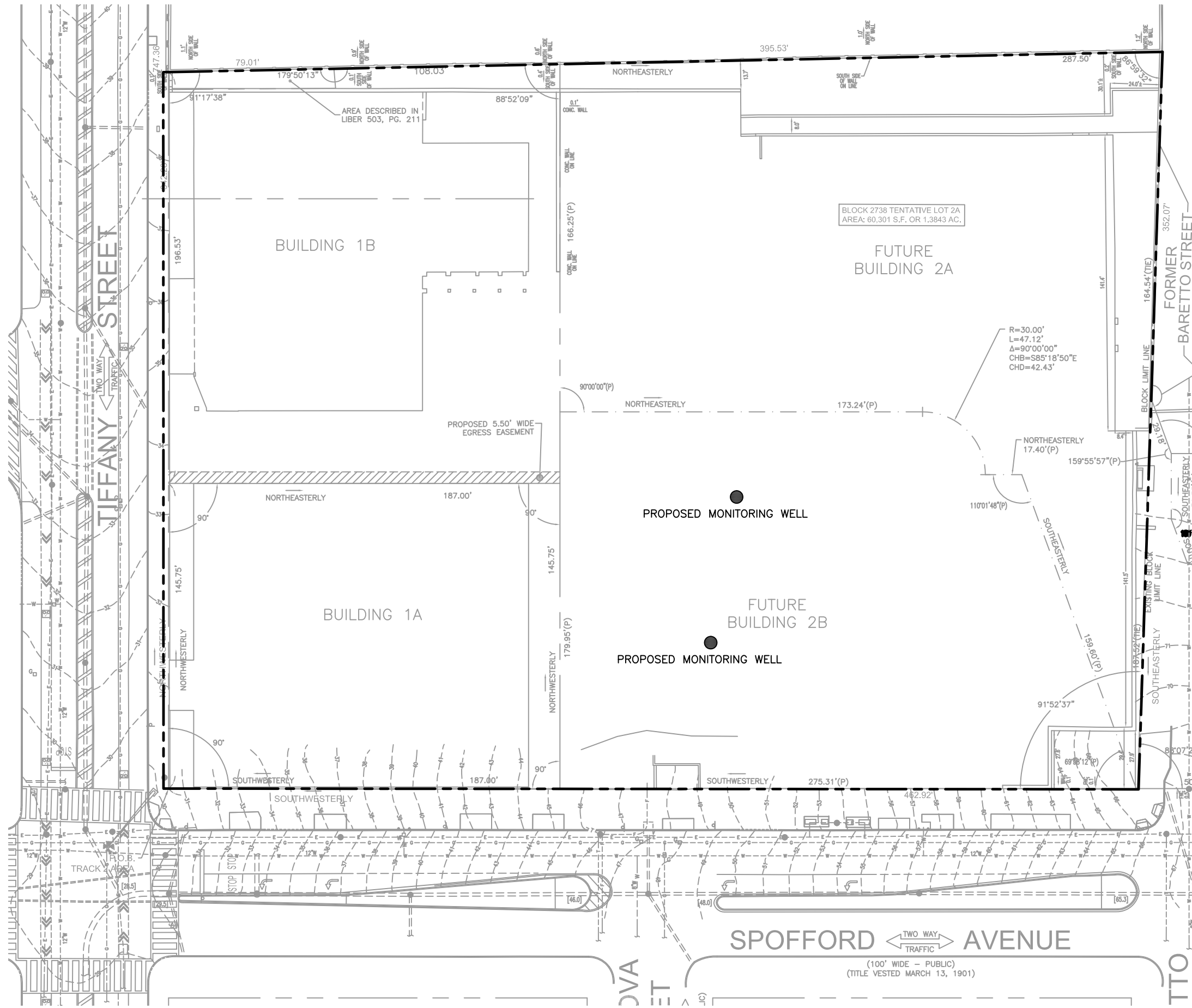

**LEGEND**

--- SITE BOUNDARY

● LOCATION OF PROPOSED MONITORING WELL

Title:			<b>SITE PLAN</b>
1221 SPOFFORD AVENUE BRONX, NEW YORK			
Prepared For:			THE PENINSULA JV, LLC
<b>ROUX</b>			
Compiled by: D.H.	Date: 30MAY18	FIGURE <b>2</b>	
Prepared by: G.M.	Scale: AS SHOWN		
Project Mgr: D.H.	Project: 2611.0002Y000		
File: 2611.0002Y108R.04.DWG			



**Figure 3. Directions to Bronx Lebanon Hospital Center**

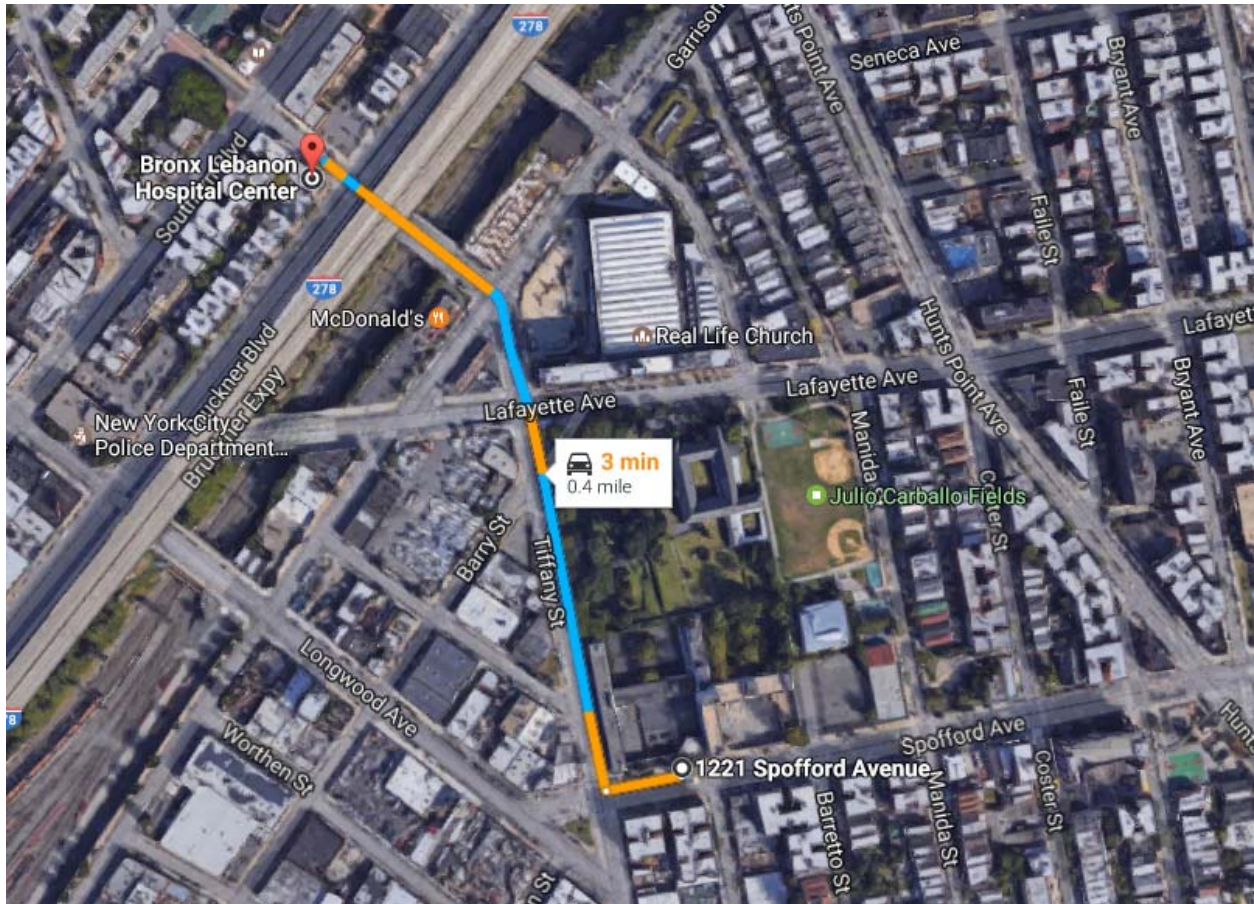

Bronx Lebanon Hospital Center  
853 Tiffany Street  
Bronx, New York, 10459

- Head west on Spofford Avenue toward Tiffany Street (187 feet);
- Turn right onto Tiffany Street (0.3 mi);
- Slight left near Garrison Ave;
- Destination will be on the left.

**Figure 4. Directions to City MD**



### City MD

80 West 125<sup>th</sup> Street

New York, New York

- 1221 Spofford Avenue, Bronx, New York;
- Head west on Spofford Avenue toward Tiffany Street (413 feet);
- Turn Right onto Longwood Avenue (0.2 mi);
- Turn left at the 3<sup>rd</sup> cross street onto Bruckner Blvd (1.0 mi);
- Keep left to stay on Bruckner Blvd (1.2 mi);
- Use middle lane to continue on Third Avenue Bridge (0.3 mi);
- Keep right to stay on Third Avenue Bridge (243 ft);
- Continue straight on E 129<sup>th</sup> Street (0.3 mi);
- Turn left onto 5<sup>th</sup> Avenue. (0.2 mi);
- Turn right onto West 125<sup>th</sup> Street, destination will be on the left (0.2 mi).

**Site-Specific Health and Safety Plan**  
***The Peninsula Redevelopment Project***  
***1221 Spofford Avenue, Bronx, New York***

---

**APPENDICES**

- A. Job Safety Analysis (JSA) Forms
- B. SDS for Chemicals Used
- C. Personal Protective Equipment (PPE) Management Program
- D. Subsurface Utility Clearance Management Procedure
- E. Heavy Equipment Exclusion Zone Policy
- F. Roux COVID-19 Interim Health and Safety Guidance
- G. CDC's Face Covering Procedure Job Safety and Health Protection Poster
- H. Community Air Monitoring Plan (CAMP)

**Site-Specific Health and Safety Plan  
The Peninsula Redevelopment Project  
1221 Spofford Avenue, Bronx, New York**

---

**APPENDIX A**

Job Safety Analysis (JSA) Forms

<b>JOB SAFETY ANALYSIS</b>		<b>Cntrl. No.</b>	DATE:	<input checked="" type="checkbox"/> NEW <input type="checkbox"/> REVISED	PAGE 1 of 2
JSA TYPE CATEGORY <b>GENERIC</b>		WORK TYPE	WORK ACTIVITY (Description)		
DEVELOPMENT TEAM	POSITION / TITLE		REVIEWED BY:	POSITION / TITLE	
<b>REQUIRED AND / OR RECOMMENDED PERSONAL PROTECTIVE EQUIPMENT</b>					
<input type="checkbox"/> LIFE VEST	<input type="checkbox"/> GOGGLES	<input type="checkbox"/> AIR PURIFYING RESPIRATOR	<input type="checkbox"/> GLOVES:		
<input type="checkbox"/> HARD HAT	<input type="checkbox"/> FACE SHIELD	<input type="checkbox"/> SUPPLIED RESPIRATOR	<input type="checkbox"/> OTHER		
<input type="checkbox"/> LIFELINE / BODY HARNESS	<input type="checkbox"/> HEARING PROTECTION	<input type="checkbox"/> PPE CLOTHING:			
<input type="checkbox"/> SAFETY GLASSES	<input type="checkbox"/> SAFETY SHOES				
<b>REQUIRED AND / OR RECOMMENDED EQUIPMENT</b>					
Required Equipment:					
<b>Commitment to LPS</b> – All personnel onsite will actively participate in SPSA performance by verbalizing SPSAs throughout the day.					
<b>EXCLUSION ZONE: A _ foot exclusion zone will be maintained around (indicate equipment).</b>					
<b>Assess 1JOB STEPS</b>	<b>Analyze 2POTENTIAL HAZARDS</b>		<b>Act 3CRITICAL ACTIONS</b>		
1. [INSERT JOB STEP]	1a. CONTACT: [INSERT HAZARD]	1a.			
	1b. CAUGHT: [INSERT HAZARD]	1b.			
	1c. FALL: [INSERT HAZARD]	1c.			
	1d. EXPOSURE: [INSERT HAZARD]	1d.			
	1e. EXERTION: [INSERT HAZARD]	1e.			
	1f. ENERGY SOURCE: [INSERT HAZARD]	1f.			
2. [INSERT JOB STEP]	2a. CONTACT: [INSERT HAZARD]	2a.			
	2b. CAUGHT: [INSERT HAZARD]	2b.			

<sup>1</sup> Each Job or Operation consists of a set of tasks / steps. Be sure to list all the steps needed to perform job.

<sup>2</sup> A hazard is a potential danger. Break hazards into five types: Contact - victim is struck by or strikes an object;

Caught - victim is caught on, caught in or caught between objects; Fall - victim falls to ground or lower level (includes slips and trips); Exertion - excessive strain or stress / ergonomics / lifting techniques; Exposure - inhalation/skin hazards.

<sup>3</sup> Using the first two columns as a guide, decide what actions or procedures are necessary to eliminate or minimize the risk. List the recommended safe operating procedures. Say exactly what needs to be done - such as "use two persons to lift." Avoid general statements such as, "be careful."

	<p><b>2c. FALL:</b> [INSERT HAZARD]</p> <p><b>2d. EXPOSURE:</b> [INSERT HAZARD]</p> <p><b>2e. EXERTION:</b> [INSERT HAZARD]</p> <p><b>2f. ENERGY SOURCE:</b> [INSERT HAZARD]</p>	<p>2c.</p> <p>2d.</p> <p>2e.</p> <p>2f.</p>
--	--	---

<sup>1</sup> Each Job or Operation consists of a set of tasks / steps. Be sure to list all the steps needed to perform job.

<sup>2</sup> A hazard is a potential danger. Break hazards into five types: Contact - victim is struck by or strikes an object;

Caught - victim is caught on, caught in or caught between objects; Fall - victim falls to ground or lower level (includes slips and trips); Exertion - excessive strain or stress / ergonomics / lifting techniques; Exposure - inhalation/skin hazards.

<sup>3</sup> Using the first two columns as a guide, decide what actions or procedures are necessary to eliminate or minimize the risk. List the recommended safe operating procedures. Say exactly what needs to be done - such as "use two persons to lift". Avoid general statements such as, "be careful".

<b>JOB SAFETY ANALYSIS</b>		<b>Ctrl. No. GEN-009</b>	DATE: 1/4/2018	<input type="checkbox"/> NEW <input checked="" type="checkbox"/> REVISED	PAGE 1 of 1
JSA TYPE CATEGORY <b>Generic</b>		WORK TYPE <b>O&amp;M</b>	WORK ACTIVITY (Description) <b>Movement of 55-Gallon Drums/Drum Handling with Mobile Carrier</b>		
<b>DEVELOPMENT TEAM</b>		<b>POSITION / TITLE</b>		<b>REVIEWED BY:</b>	
Michael Sarni		Technician		Brian Hobbs	
				Joe Gentile	
				Senior Health & Safety Manager	
				Corporate Health & Safety Manager	
<b>REQUIRED AND / OR RECOMMENDED PERSONAL PROTECTIVE EQUIPMENT</b>					
<input type="checkbox"/> LIFE VEST <input checked="" type="checkbox"/> HARD HAT <input type="checkbox"/> LIFELINE / BODY HARNESS <input checked="" type="checkbox"/> SAFETY GLASSES		<input type="checkbox"/> GOGGLES <input type="checkbox"/> FACE SHIELD <input type="checkbox"/> HEARING PROTECTION <input checked="" type="checkbox"/> SAFETY SHOES: <u>Steel or composite toe</u>		<input type="checkbox"/> AIR PURIFYING RESPIRATOR <input type="checkbox"/> SUPPLIED RESPIRATOR <input checked="" type="checkbox"/> PPE CLOTHING: <u>Fluorescent long sleeve shirt or long sleeve shirt and reflective safety vest.</u>	
				<input checked="" type="checkbox"/> GLOVES: <u>Cut-resistant gloves</u> <input type="checkbox"/> OTHER:	
<b>REQUIRED AND / OR RECOMMENDED EQUIPMENT</b>					
Mobile Drum Carrier, safety cones, and caution tape					
<b>COMMITMENT TO SAFETY-</b> All personnel onsite will actively participate in hazard recognition and mitigation throughout the day by verbalizing SPSAs					
<b>EXCLUSION ZONE (EZ): A 10-foot exclusion zone will be maintained around heavy equipment (i.e. forklift).</b>					
<b>Assess 1JOB STEPS</b>		<b>Analyze 2POTENTIAL HAZARDS</b>		<b>Act 3CRITICAL ACTIONS</b>	
1. Preparing for and Inspection of Drum		<b>1a. FALL:</b> Tripping/falling due to uneven surface. Loose debris/garbage in work area.  <b>1b. CONTACT/EXPOSURE:</b> Drums could potentially be damaged or contain hazardous material. Mobile drum carrier could potentially be in poor working condition causing malfunctioning during operation.  <b>1c. EXERTION/CAUGHT:</b> Potential pinching/exertion hazards while securing ring/tightening bolts		1a. Clear area of loose garbage and debris. Inspect 55-gal drums for proper condition, labeling, check drum ring and bolts for tightness, inspect mobile drum carrier.  1a. Do a Test Lift to get a general sense of the weight of the drum.  1a. Inspect and use established pathways to avoid uneven terrain, weather-related hazards (i.e., debris, puddles, ice, etc.), and other obstructions.  1a. Secure work area and coordinate and communicate the planned work activities with other personnel working in the area.  1a. Delineate work area with 42" safety cones.  1b. Prior to inspecting drums don cut-resistant gloves. If drum is not properly labeled, do not open and cease all drum transport activities. Immediately contact project manager and inform him/her of drum situation.  1b. Do not continue drum transport activities until further actions are determined by the project manager.  1b. If the drum is properly labeled, but leaking, improperly sealed or in poor condition, place drum in an over-pack drum.  1b. Inspect mobile drum carrier to ensure its overall integrity. Look for rust marks or potential weak points where the drum carrier could malfunction. Inspect the wheels to ensure that they easily turn and nothing is impeding their movement.  1c. Keep back straight and knees slightly bent while securing drum ring/tightening bolt. Wear cut-resistant gloves.	
2. Position drum clamp tightly in between drum ribs, securing drum clamp to drum with chain		2a. <b>CAUGHT:</b> Pinching fingers between drum clamp and handle/chain.		2a. Attach drum clamp with chain and tighten until snug. Do not place hands between drum clamp and drum as the chain is tightened; wear cut resistant gloves. Keep face away from drum when handling in case of escaping vapors.	

<sup>1</sup> Each Job or Operation consists of a set of tasks / steps. Be sure to list all the steps needed to perform job.  
<sup>2</sup> A hazard is a potential danger. Break hazards into six types: Contact - victim is struck by or strikes an object; Caught - victim is caught on, caught in or caught between objects; Fall - victim falls to ground or lower level (includes slips and trips); Exertion - excessive strain or stress / ergonomics / lifting techniques; Exposure - inhalation/skin hazards; Energy source - electricity, pressure, compression/tension.  
<sup>3</sup> Using the first two columns as a guide, decide what actions or procedures are necessary to eliminate or minimize the risk. List the recommended safe operating procedures. Say exactly what needs to be done - such as "use two persons to lift." Avoid general statements such as, "be careful."

Assess 1JOB STEPS	Analyze 2POTENTIAL HAZARDS	Act 3CRITICAL ACTIONS
<p><b>3.</b> Disengage safety latches on handle, pull handle down until drum is lifted off ground and safety latches are reengaged; slightly suspending drum off the ground</p>	<p><b>3a. EXERTION/ CONTACT:</b> Potential muscle strain associated with lifting/engaging drum/handle. Drum could shift/slip downward and crush toes.</p> <p><b>3b. CAUGHT:</b> Fingers could be pinched while engaging/disengaging safety latches on handle</p>	<p>3a. Ascertain whether the drum is overweight; if it is, then two people are needed to lower handle while drum is secured with clamp so that safety latches can be engaged. Keep body out of the line of fire of the handle (do not position head above handle) as it is being pushed down. Do not allow feet/toes to be positioned under the drum as it is being lifted; wear steel/composite toe boots.</p> <p>3b. Wear cut-resistant gloves while disengaging/reengaging safety latches.</p> <p>3b. Avoid placing hands in pinch points.</p>
<p><b>4.</b> Transport drums to designated location and disengage drum clamp (repeat Step 3 in reverse order)</p>	<p><b>4a. FALL:</b> Tripping/ falling due to obstructions and uneven terrain. Potential for drum to fall during transport.</p>	<p>4a. Ensure transport path is free of potential obstructions that may cause the drum/carrier to become unstable. Position drum clamp between the ribs on the drum to prevent possible slipping.</p>

<sup>1</sup> Each Job or Operation consists of a set of tasks / steps. Be sure to list all the steps needed to perform job.

<sup>2</sup> A hazard is a potential danger. Break hazards into six types: Contact - victim is struck by or strikes an object; Caught - victim is caught on, caught in or caught between objects; Fall - victim falls to ground or lower level (includes slips and trips); Exertion - excessive strain or stress / ergonomics / lifting techniques; Exposure - inhalation/skin hazards; Energy source – electricity, pressure, compression/tension.

<sup>3</sup> Using the first two columns as a guide, decide what actions or procedures are necessary to eliminate or minimize the risk. List the recommended safe operating procedures. Say exactly what needs to be done - such as "use two persons to lift." Avoid general statements such as, "be careful."



<b>JOB SAFETY ANALYSIS</b>		<b>Ctrl. No. GEN-015</b>	DATE: 1/4/2018	<input type="checkbox"/> NEW <input checked="" type="checkbox"/> REVISED	PAGE 1 of 2
JSA TYPE CATEGORY <b>GENERIC</b>		WORK TYPE <b>Site Recon</b>	WORK ACTIVITY (Description) <b>Mobilization/Demobilization</b>		
<b>DEVELOPMENT TEAM</b>		<b>POSITION / TITLE</b>	<b>REVIEWED BY:</b>	<b>POSITION / TITLE</b>	
Rebecca Lowy		Staff Assistant Geologist	Brian Hobbs	Senior Health & Safety Manager	
Tally Sodre		OHSM	Joe Gentile	Corporate Health & Safety Manager	
<b>REQUIRED AND / OR RECOMMENDED PERSONAL PROTECTIVE EQUIPMENT</b>					
<input type="checkbox"/> LIFE VEST <input checked="" type="checkbox"/> HARD HAT <input type="checkbox"/> LIFELINE / BODY HARNESS <input checked="" type="checkbox"/> SAFETY GLASSES		<input type="checkbox"/> GOGGLES <input type="checkbox"/> FACE SHIELD <input checked="" type="checkbox"/> HEARING PROTECTION (as needed) <input checked="" type="checkbox"/> SAFETY SHOES: <u>Steel Toe or composite toe</u>	<input type="checkbox"/> AIR PURIFYING RESPIRATOR <input type="checkbox"/> SUPPLIED RESPIRATOR <input checked="" type="checkbox"/> PPE CLOTHING: <u>Fluorescent reflective vest of high-visibility clothing; long sleeve shirt; long pants</u>	<input checked="" type="checkbox"/> GLOVES: <u>Leather, nitrile, and cut resistant (as needed)</u> <input type="checkbox"/> OTHER	
<b>REQUIRED AND / OR RECOMMENDED EQUIPMENT</b>					
Required Equipment: None					
<b>COMMITMENT TO SAFETY-</b> All personnel onsite will actively participate in hazard recognition and mitigation throughout the day by verbalizing SPSAs					
<b>EXCLUSION ZONE (EZ): A 10-foot exclusion zone will be maintained around equipment in use..</b>					
<b>Assess 1JOB STEPS</b>	<b>Analyze 2POTENTIAL HAZARDS</b>	<b>Act 3CRITICAL ACTIONS</b>			
1. Mobilize/demobilize and establish work area	<b>1a. FALL:</b> Slip/trips/falls from obstructions, uneven terrain, weather conditions, heavy loads, and/or poor housekeeping.  <b>1b. CONTACT:</b> Personal injury and/or property damage caused by being struck by Site traffic or equipment used in Site activities.	1a. Use 3 points-of-contact/ensure secure footing when entering and exiting vehicle. 1a. Inspect walking path for uneven terrain, steep hills, obstructions, and/or weather-related hazards (i.e., ice, snow, and puddles) prior to mobilizing equipment. Use established pathways. Walk on stable/secure ground. 1a. Do not climb over stored materials/equipment; walk around. Practice good housekeeping; organize and store equipment neatly in one area at its lowest potential energy. 1a. Wear boots with adequate treads. 1a. Delineate unsafe areas with 42" cones, caution tape and/or flagging.  1b. Observe and maintain the posted speed limits. 1b. When first arriving onsite, park vehicles in designated parking space and/or out of the way locations. Use parking brake on all vehicles and tire chocks on work trucks and trailers. 1b. Check in with Site Manager/Supervisor to ensure coordination with other Site activities and to discuss any special hazards. Ensure that short-service employees (SSE) are identified. 1b. Identify potential traffic sources. 1b. Wear PPE including high visibility clothing or reflective vest. 1b. Use a spotter while moving work vehicles; plan ahead to avoid backing whenever possible. 1b. Maintain a minimum 10' exclusion zone when vehicles are in motion. When backing up truck rig with an attached trailer use a second spotter if there is tight clearance simultaneously on multiple sides of the equipment or if turning angles limit driver-to-spotter visibility. 1b. Delineate work area with 42" cones, flags, caution tape, and/or other barriers. 1b. Position "Work Area" signs at Site entrances, if possible, or at either side of work area.			

<sup>1</sup> Each Job or Operation consists of a set of tasks / steps. Be sure to list all the steps needed to perform job.

<sup>2</sup> A hazard is a potential danger. Break hazards into five types: Contact - victim is struck by or strikes an object;

Caught - victim is caught on, caught in or caught between objects; Fall - victim falls to ground or lower level (includes slips and trips); Exertion - excessive strain or stress / ergonomics / lifting techniques; Exposure - inhalation/skin hazards; Energy Source - electricity, pressure, compression/tension.

<sup>3</sup> Using the first two columns as a guide, decide what actions or procedures are necessary to eliminate or minimize the risk. List the recommended safe operating procedures. Say exactly what needs to be done - such as "use two persons to lift." Avoid general statements such as, "be careful."

Assess <sup>1</sup> JOB STEPS	Analyze <sup>2</sup> POTENTIAL HAZARDS	Act <sup>3</sup> CRITICAL ACTIONS
	<p><b>1c. CAUGHT:</b> Personal injury from pinch points and being in line-of-fire of vehicle and/or equipment.</p> <p><b>1d. OVEREXERTION:</b> Muscle strains while lifting/carrying equipment.</p> <p><b>1e. EXPOSURE:</b> Personal injury from exposure to biological and environmental hazards.</p> <p><b>1f. EXPOSURE:</b> Weather related injuries.</p> <p><b>1g. EXPOSURE:</b> Personal injury from noise hazards.</p>	<p>1b. Position largest vehicle to protect against oncoming traffic.</p> <p>1b. Face traffic, maintain eye contact with oncoming vehicles, use a spotter, and establish a safe exit route.</p> <p>1b. Observe potential overhead and ground surface features that may interfere with moving equipment. Clear the path of physical hazards prior to initiating mobilization.</p> <p>1c. Make sure driver has engaged parking brake and placed wheel chocks in a position to prevent movement. Be sure that vehicle is parked in front/down gradient (positioned to best block oncoming traffic) of work area.</p> <p>1c. Wear leather gloves when handling any tools or equipment. Wear cut-resistant gloves (Kevlar or similar) when handling sharp objects/cutting tools/glass.</p> <p>1c. Keep body parts away from line-of-fire of equipment.</p> <p>1c. Always carry tools by the handles and/or designated carrier. Ensure sharp-edged tools are sheathed/secure.</p> <p>1c. Remove any loose jewelry. Avoid wearing loose clothing and/or ensure loose clothing is secure.</p> <p>1c. Secure all items on the equipment, tighten up any items or features that have potential to shift or break during mobilization.</p> <p>1d. Use body positioning and lifting techniques that avoid muscle strain; keep back straight, lift with legs, turn with whole body, keep load close to body, and never reach with a load.</p> <p>1d. Ensure that loads are balanced. Use assistance (mechanical or additional person) to carry equipment that is either unwieldy or over 50 lbs.</p> <p>1e. Inspect area to avoid contact with biological hazards (i.e. poisonous plants, stinging insects, ticks, etc.).</p> <p>1e. Wear long sleeved clothes treated with Permethrin, apply insect repellent containing DEET to exposed skin, and inspect clothes and skin for ticks during and after work.</p> <p>1e. Apply sunscreen (SPF 15+) if exposure to sun for 30 minutes or more is expected.</p> <p>1f. Watch for heat stress symptoms (muscle cramping, exhaustion, dizziness, nausea, rapid and shallow breathing). Take breaks in cool places and hydrate as needed.</p> <p>1f. Watch for cold stress symptoms (severe shivering, slowing of body movement, weakness, stumbling or inability to walk, collapse). Take breaks in warm areas as needed.</p> <p>1f. Wear clothing appropriate for weather and temperature conditions (e.g., rain jackets, snow pants, multiple layers).</p> <p>1f. If lightning is observed, wait 30 minutes in a sheltered location (car is acceptable) before resuming work.</p> <p>1g. Wear hearing protection if sound levels exceed 85 dBA (if you must raise your voice for normal conversation).</p>

<sup>1</sup> Each Job or Operation consists of a set of tasks / steps. Be sure to list all the steps needed to perform job.

<sup>2</sup> A hazard is a potential danger. Break hazards into five types: Contact - victim is struck by or strikes an object; Caught - victim is caught on, caught in or caught between objects; Fall - victim falls to ground or lower level (includes slips and trips); Exertion - excessive strain or stress / ergonomics / lifting techniques; Exposure - inhalation/skin hazards; Energy Source – electricity, pressure, compression/tension.

<sup>3</sup> Using the first two columns as a guide, decide what actions or procedures are necessary to eliminate or minimize the risk. List the recommended safe operating procedures. Say exactly what needs to be done - such as "use two persons to lift". Avoid general statements such as, "be careful".

<b>JOB SAFETY ANALYSIS</b> <b>Ctrl. No. GEN-020</b>		DATE: 1/4/2018	<input type="checkbox"/> NEW <input checked="" type="checkbox"/> REVISED	PAGE 1 of 2
JSA TYPE CATEGORY: <b>GENERIC</b>	WORK TYPE: <b>Gauging &amp; Sampling</b>	WORK ACTIVITY (Description): <b>Soil Sampling</b>		
<b>DEVELOPMENT TEAM</b>	<b>POSITION / TITLE</b>	<b>REVIEWED BY:</b>	<b>POSITION / TITLE</b>	
MaryBeth Lyons	Project Scientist	Brian Hobbs	Senior Health & Safety Manager	
		Joe Gentile	Corporate Health and Safety Manager	
<b>REQUIRED AND / OR RECOMMENDED PERSONAL PROTECTIVE EQUIPMENT</b>				
<input type="checkbox"/> LIFE VEST <input checked="" type="checkbox"/> HARD HAT <input type="checkbox"/> LIFELINE / BODY HARNESS <input checked="" type="checkbox"/> SAFETY GLASSES <input checked="" type="checkbox"/> FLAME RESISTANT CLOTHING (as needed)	<input type="checkbox"/> GOGGLES <input type="checkbox"/> FACE SHIELD: <input checked="" type="checkbox"/> HEARING PROTECTION: (as needed) <input checked="" type="checkbox"/> SAFETY SHOES: Composite-toe or steel toe boots	<input type="checkbox"/> AIR PURIFYING RESPIRATOR <input type="checkbox"/> SUPPLIED RESPIRATOR <input checked="" type="checkbox"/> PPE CLOTHING: Fluorescent reflective vest or high visibility clothing	<input checked="" type="checkbox"/> GLOVES: Leather, Nitrile and cut resistant <input checked="" type="checkbox"/> OTHER: Insect repellent, sunscreen (as needed)	
<b>REQUIRED AND / OR RECOMMENDED EQUIPMENT</b>				
Recommended Equipment: 42" traffic cones, caution tape, trowel				
<b>COMMITMENT TO SAFETY-</b> All personnel onsite will actively participate in hazard recognition and mitigation throughout the day by verbalizing SPSAs.				
<b>EXCLUSION ZONE (EZ): A 10-foot exclusion zone will be maintained around moving equipment, if present.</b>				
<b>Assess 1JOB STEPS</b>	<b>Analyze 2POTENTIAL HAZARDS</b>	<b>Act 3CRITICAL ACTIONS</b>		
1. Secure location	<p><b>1a. CONTACT:</b> Personnel and vehicular traffic may enter the work area.</p> <p><b>1b. FALL:</b> Tripping/falling due to uneven terrain or entry/exit from excavations.</p> <p><b>1c. EXPOSURE:</b> Exposure to sun and excessive heat, possibly causing sunburn, heat exhaustion or heat stroke.  Exposure to cold temperatures possibly causing cold stress.  Skin burn as a result of fire, if applicable.  Exposure to explosive vapors due to tank farm operations.  Exposure to airborne dust due to high wind speeds.  Biological hazards - ticks, bees/wasps, poison ivy, thorns, insects, etc.</p>	<p>1a. If in an area with foot or vehicle traffic, delineate the work area with 42" traffic cones and/or caution tape to prevent exposure to traffic and inform others of work activity.</p> <p>1a. Wear reflective vest and/or high visibility clothing.</p> <p>1a. Face the direction of any vehicular traffic. Position vehicle to protect worker from traffic.</p> <p>1a. Communicate work activity with adjacent work areas.</p> <p>1b. Inspect pathways and work area for uneven terrain, weather-related hazards (i.e., ice, puddles, snow, etc.), and obstructions.</p> <p>1b. Use established pathways and walk on stable, secure ground.</p> <p>1b. Stage equipment and tools in a convenient, stable, and orderly manner. Store equipment at lowest potential energy.</p> <p>1b. Roux employees should stay 5 feet from in-progress excavations and trenches. Should entry to an excavation be required (when stabilization is complete), ladders must be employed for steep embankments, excavations, pits, and trenches.</p> <p>1c. Wear sunscreen with an SPF 15 or greater whenever 30 minutes or more of exposure is expected.</p> <p>1c. Use a tent to shade the work area from direct sunlight particularly when warm temperatures are expected.</p> <p>1c. Be aware of the location of all Site personnel.</p> <p>1c. Watch for heat stress symptoms (muscle cramping, exhaustion, dizziness, rapid and shallow breathing).</p> <p>1c. Watch for cold stress symptoms (severe shivering, slowing of body movement, weakness, stumbling or inability to walk, collapse).</p> <p>1c. Take breaks for rest and water as necessary. Move to an area that is well shaded or a climate controlled area (i.e., car, site trailer, etc.).</p> <p>1c. No open flames/heat sources.</p> <p>1c. Flame retardant clothing must be worn when specified by Site policy.</p> <p>1c. Cell phones should be disabled when specified by Site policy.</p> <p>1c. Pre-treat field clothing with Permethrin prior to site visit to kill ticks and insects.</p> <p>1c. Wear long sleeved shirts and tuck in (or tape) pant legs into socks or boots to prevent ticks from reaching skin.</p> <p>1c. Spray insect repellent containing DEET on exposed skin when working in overgrown areas of the Site.</p> <p>1c. Inspect area to avoid contact with biological hazards.</p> <p>1c. Wear cut-resistant gloves when handling branches, shrubs, etc. that may lie within the walking path.</p> <p>1c. Wear spoggles if the average wind speeds are above 15 mph.</p> <p>1c. Personnel shall examine themselves and co-worker's outer clothing for ticks periodically when onsite.</p> <p>1c. If skin comes in contact with poison ivy, wash skin thoroughly with soap and water. If rash persists after washing, immediately notify your supervisor, the OM and OHSM for possible consultation with a physician at an approved Occupational Health Clinic.</p>		

<sup>1</sup> Each Job or Operation consists of a set of tasks / steps. Be sure to list all the steps needed to perform job.

<sup>2</sup> A hazard is a potential danger. Break hazards into five types: Contact - victim is struck by or strikes an object; Caught - victim is caught on, caught in or caught between objects; Fall - victim falls to ground or lower level (includes slips and trips); Exertion - excessive strain or stress / ergonomics / lifting techniques; Exposure - inhalation/skin hazards; Energy Source - electricity, pressure, compression/tension.

<sup>3</sup> Using the first two columns as a guide, decide what actions or procedures are necessary to eliminate or minimize the risk. List the recommended safe operating procedures. Say exactly what needs to be done - such as "use two persons to lift". Avoid general statements such as, "be careful".

Assess <sup>1</sup> JOB STEPS	Analyze <sup>2</sup> POTENTIAL HAZARDS	Act <sup>3</sup> CRITICAL ACTIONS
2. Collect Soil Sample	<p><b>2a. CONTACT:</b> Personal injury from pinch points, cuts, and abrasions from sampling equipment tools, and material within soil sample. Personal injury from contact with moving equipment while sampling. Personal injury from contact with glass sample jars.</p> <p><b>2b. EXPOSURE:</b> Exposure to contamination (impacted soil) and/or lab preservatives.</p> <p><b>2c. EXERTION:</b> Exertion due to repetitive motion and ergonomics.</p>	<p>2a. Wear cut-resistant (i.e., Kevlar) gloves under chemical-resistant (nitrile) disposable gloves when handling soil samples and sampling jars. 2a. Where possible, use trowel or equivalent tool to avoid contact with soil. 2a. If sampling from bucket of heavy equipment, ensure all equipment is off and operator utilizes the "show me your hands" policy. 2a. See 1a.</p> <p>2b. Wear chemical-resistant (nitrile) disposable gloves over cut resistant gloves to protect hands when handling samples; use containment material or plastic sheeting to protect surrounding areas. 2b. Wear safety glasses to protect eyes from dust or air-borne contaminants that may result from disturbing the soil. 2b. Where possible, remain upgradient from sample location if collecting soil sample from stockpile, drill rig, etc. to avoid breathing contaminant vapors, if they are present. 2b. When collecting soil sample from hand auger, put large zip lock bag over entire auger to prevent spillage of soil on to the ground. 2b. Open sample jars slowly and fill carefully to avoid contact with preservatives.</p> <p>2c. Utilize a table or raised surface for soil sampling if multiple soil samples are going to be taken to minimize repetitive bending motion.</p>
3. Decontaminate equipment	<p><b>3a. EXPOSURE/CONTACT:</b> Contamination (e.g., Separate Phase Hydrocarbons (SPH), contaminated vapors and/or soil).</p> <p><b>3b. EXPOSURE:</b> Chemicals in cleaning solution including ammonia.</p>	<p>3a. Wear chemical-resistant (nitrile) disposable gloves and safety glasses. 3a. Use an absorbent pad to clean spills. 3a. Properly dispose of used materials/PPE in provided drums in designated drum storage area. 3a. Remain upwind of sample and avoid breathing contaminant vapors, if they are present.</p> <p>3b. Wear chemical-resistant (nitrile) disposable gloves and safety glasses. 3b. Work on the upwind side of decontamination area. 3b. Use an absorbent pad to clean spills. 3b. Properly dispose of used materials/PPE in provided drums in designated drum storage area. Ensure that all drums are properly labeled and secured.</p>

<sup>1</sup> Each Job or Operation consists of a set of tasks / steps. Be sure to list all the steps needed to perform job.

<sup>2</sup> A hazard is a potential danger. Break hazards into five types: Contact - victim is struck by or strikes an object; Caught - victim is caught on, caught in or caught between objects; Fall - victim falls to ground or lower level (includes slips and trips); Exertion - excessive strain or stress / ergonomics / lifting techniques; Exposure - inhalation/skin hazards; Energy Source – electricity, pressure, compression/tension.

<sup>3</sup> Using the first two columns as a guide, decide what actions or procedures are necessary to eliminate or minimize the risk. List the recommended safe operating procedures. Say exactly what needs to be done - such as "use two persons to lift". Avoid general statements such as, "be careful".

<b>JOB SAFETY ANALYSIS</b>		<b>Ctrl. No. GEN-003</b>	DATE 8/6/2018	<input type="checkbox"/> NEW <input checked="" type="checkbox"/> REVISED	PAGE 1 of 2
JSA TYPE CATEGORY <b>GENERIC</b>	WORK TYPE <b>Construction - Excavation</b>	WORK ACTIVITY (Description) <b>Backfilling Excavation &amp; Compaction</b>			
<b>DEVELOPMENT TEAM</b>	<b>POSITION / TITLE</b>	<b>REVIEWED BY:</b>		<b>POSITION / TITLE</b>	
David Kaiser	Project Engineer	Brian Hobbs		Corporate Health & Safety Manager	
Edward Lacina	Senior Construction Manager				
<b>REQUIRED AND / OR RECOMMENDED PERSONAL PROTECTIVE EQUIPMENT</b>					
<input type="checkbox"/> LIFE VEST <input checked="" type="checkbox"/> HARD HAT <input type="checkbox"/> LIFELINE / BODY HARNESS <input checked="" type="checkbox"/> SAFETY GLASSES	<input type="checkbox"/> GOGGLES <input type="checkbox"/> FACE SHIELD <input checked="" type="checkbox"/> HEARING PROTECTION <input checked="" type="checkbox"/> SAFETY TOE BOOTS	<input type="checkbox"/> AIR PURIFYING RESPIRATOR <input type="checkbox"/> SUPPLIED RESPIRATOR <input checked="" type="checkbox"/> PPE CLOTHING: <u>reflective DOT</u> approved safety	<input checked="" type="checkbox"/> GLOVES: <u>Leather/ cut-resistant</u> <u>level 2</u> <input type="checkbox"/> OTHER _____		
<b>REQUIRED AND / OR RECOMMENDED EQUIPMENT</b>					
Payloader, Backhoe, Dump Trucks, Mechanical gas powered tampers, Excavator with hydraulic tamper. APR when tamping if dust present. Two-way radios.					
<b>COMMITMENT TO SAFETY-</b> All personnel onsite will actively participate in hazard recognition and mitigation throughout the day by verbalizing SPSAs.					
<b>EXCLUSION ZONE: A 10' minimum exclusion zone will be maintained around excavator, backhoe, tampers, and dump trucks.</b>					
<b>Assess 1JOB STEPS</b>	<b>Analyze 2POTENTIAL HAZARDS</b>	<b>Act 3CRITICAL ACTIONS</b>			
1. Pre-construction meeting: Review proposed excavation locations	1a. <b>CONTACT:</b> Potential for contact with subsurface utilities and above ground utilities	1a. Call state 811 for mark out service and one call ticket. 1a. Obtain private utility mark out service as necessary. 1a. Review and mark proposed excavations w/white paint. 1a. Identify all "Critical" zones. A Critical zone is any area within 10 feet of any operating utility. 1a. <b>Complete subsurface clearance checklist.</b> 1a. Soft dig must be conducted within 2 lateral feet of any suspected underground utility. 1a. Protection of aboveground utilities identified as being located within the work zone must be coordinated w/ client and utility owner.			
2. Secure Work Area	2a. <b>CONTACT:</b> Potential for personnel to enter the work area.  Potential for equipment to contact, or crush personnel.  2b. <b>EXERTION:</b> Potential for muscle strain or tear while installing traffic cones and barrel	2a. Ensure work area is secure and inform others of work activity. Establish a heavy equipment exclusion zone (HEEZ) using 42" traffic cones, barrels & snow fencing or telescoping poles.  Use of flag persons to maintain clear traffic and to minimize motorist confusion during set-up of new traffic pattern. HEEZ to include tip/swing radius of equipment. 2a. Dump Truck/Excavator/Payloader/Backhoe equipment to be set-up by personnel who are familiar with machinery. Spotters shall be in place for all equipment. and to control access to the HEEZ 2a. Truck wheels are chocked when driver is not in truck and engine shut off. 2a. Personnel shall stay out of the exclusion zone (10' minimum or greater than the equipment boom) while equipment is maneuvering. 2b. Keep back straight, keep load close to the body and bend knees while lifting and working. If over 50 lbs., use 2 or more laborers for lifting or use of equipment.			

<sup>1</sup> Each Job or Operation consists of a set of tasks / steps. Be sure to list all the steps needed to perform job.

<sup>2</sup> A hazard is a potential danger. Break hazards into six types: Contact - victim is struck by or strikes an object; Caught - victim is caught on, caught in or caught between objects; Fall - victim falls to ground or lower level (includes slips and trips); Exertion - excessive strain or stress / ergonomics / lifting techniques; Exposure - inhalation/skin hazards; Energy Source - electricity, pressure, compression/tension.

<sup>3</sup> Using the first two columns as a guide, decide what actions or procedures are necessary to eliminate or minimize the risk. List the recommended safe operating procedures. Say exactly what needs to be done - such as "use two persons to lift". Avoid general statements such as, "be careful".

<p><b>3. Backfilling excavation, and compaction</b></p>	<p><b>3a. CONTACT:</b> Traffic and live equipment.</p> <p><b>3b. EXPOSURE:</b> Fumes from gas powered tamper</p> <p><b>3c. FALL:</b> Slips, trips, fall hazards.</p> <p><b>3d. OVEREXERTION:</b> Muscle strain, or tear.</p> <p><b>3e. EXPOSURE:</b> Noise from tamper.  Dust inhalation.</p>	<p>3a. Equipment and trucks shall be isolated from other workers, subcontractors and third party traffic with 42" traffic cones, barricades, snow fencing or telescoping poles, and/or Jersey barriers. Spotters shall direct dump truck for placement of fill near excavation. Pay loader/ Excavator, as directed by spotter, shall move fill into trench where it shall be placed in layers and compacted by mechanical means.</p> <p>3a. Spotters will wear florescent vests at all times.</p> <p>3a. Spotters will remain out of the exclusion zone, line of fire from equipment and third-party vehicles.</p> <p>3a. Spotters and operators will have radios for communication, when other visual and/or hand signals are insufficient.</p> <p>3a. Locate all overhead utilities. All personnel and machinery should maintain a 10' distance from overhead electric lines. Refer to OSHA chart for distances and voltage.</p> <p>3a. For excavations engineered (shored, sloped, benched) all personnel, equipment, and materials must remain a minimum of 2 feet from edge of excavation.</p> <p>3b. Fueling of all equipment will be done outside of work area in a well-ventilated area. Refueling will be done only after a 2-5-minute cool down.</p> <p>3c. Work area will be clean and free of any debris to remove slip, trip and fall hazards. All tools will be kept in designated areas. Insure work area is well illuminated.</p> <p>3c. Workers should only be working in areas that have been leveled with a machine.</p> <p>3c. All persons working at elevations over 6' shall use a guardrail system or personal fall arrest system while around excavation.</p> <p>3d. Keep knees bent and back straight while transferring/ lifting/lowering tamper from elevated areas. Utilize a co-worker to avoid staining muscles.</p> <p>3d. Keep knees bent and back straight while maneuvering tamper. Utilize a co-worker to avoid staining muscles.</p> <p>3e. Workers will wear hearing protection during compaction tamper activities.</p> <p>3e. Wear NIOSH approved dust mask for personal comfort. If dust is visible for extended time, limit by wetting down area.</p> <p>3e. If dust continues stop work and evaluate if APR is needed with approval and clearance.</p>
<p><b>4. Secure/leave site.</b></p>	<p><b>4a. FALL:</b> Slip, trip, fall</p>	<p>4a. Clear work area of all debris and store all equipment in designated areas/containers before opening to traffic.</p> <p>4a. Replace fencing and barricades as needed to secure path before opening roadway or area up to traffic(vehicle, pedestrian and/or bicycle).</p>

<sup>1</sup> Each Job or Operation consists of a set of tasks / steps. Be sure to list all the steps needed to perform job.

<sup>2</sup> A hazard is a potential danger. Break hazards into six types: Contact - victim is struck by or strikes an object; Caught - victim is caught on, caught in or caught between objects; Fall - victim falls to ground or lower level (includes slips and trips); Exertion - excessive strain or stress / ergonomics / lifting techniques; Exposure - inhalation/skin hazards; Energy Source - electricity, pressure, compression/tension.

<sup>3</sup> Using the first two columns as a guide, decide what actions or procedures are necessary to eliminate or minimize the risk. List the recommended safe operating procedures. Say exactly what needs to be done - such as "use two persons to lift". Avoid general statements such as, "be careful".

<b>JOB SAFETY ANALYSIS</b>		<b>Ctrl. No. GEN-004</b>	DATE 1/4/2018	<input type="checkbox"/> NEW <input checked="" type="checkbox"/> REVISED	PAGE 1 of 2
JSA TYPE CATEGORY <b>GENERIC</b>	WORK TYPE <b>Construction - Concrete and Asphalt</b>	WORK ACTIVITY (Description) <b>Concrete Form Assembly and Concrete Pouring</b>			
<b>DEVELOPMENT TEAM</b>	<b>POSITION / TITLE</b>	<b>REVIEWED BY:</b>		<b>POSITION / TITLE</b>	
David Kaiser	Project Engineer	Brian Hobbs		Corporate Health & Safety Manager	
<b>REQUIRED AND / OR RECOMMENDED PERSONAL PROTECTIVE EQUIPMENT</b>					
<input type="checkbox"/> LIFE VEST <input checked="" type="checkbox"/> HARD HAT <input type="checkbox"/> LIFELINE / BODY HARNESS <input checked="" type="checkbox"/> SAFETY GLASSES	<input type="checkbox"/> GOGGLES <input checked="" type="checkbox"/> FACE SHIELD <input checked="" type="checkbox"/> HEARING PROTECTION <input checked="" type="checkbox"/> SAFETY TOE BOOTS: <u>Steel /composite toe boots</u>	<input checked="" type="checkbox"/> AIR PURIFYING RESPIRATOR <input type="checkbox"/> SUPPLIED RESPIRATOR <input checked="" type="checkbox"/> PPE CLOTHING: <u>reflective DOT approved safety</u>	<input checked="" type="checkbox"/> GLOVES: <u>Cut resistant and Nitrile/Latex</u> <input checked="" type="checkbox"/> OTHER: Chaps, dust mask		
<b>REQUIRED AND / OR RECOMMENDED EQUIPMENT</b>					
Wheel Barrow, Trowels, Concrete Floats and Hand Tools (Extension Poles), Waterproof Boot Covers, Traffic Cones, Caution Tape, Portable Eye Wash Station					
<b>COMMITMENT TO SAFETY-</b> All personnel onsite will actively participate in hazard recognition and mitigation throughout the day by verbalizing SPSAs.					
<b>EXCLUSION ZONE: A 10' minimum exclusion zone will be maintained around equipment and loads while it is in motion.</b>					
<b>Assess JOB STEPS</b>	<b>Analyze POTENTIAL HAZARDS</b>	<b>Act CRITICAL ACTIONS</b>			
1. Set-up work zone	<b>1a. CONTACT:</b> Moving equipment, third party traffic.	1a. Secure work area using barricades/barrels/cones and caution tape/safety fence. Use flagmen to control third party traffic. <b>Maintain minimum exclusion zone (EZ) of 10'</b> around equipment and live loads.  1a. When machines are operating, all workers will remain outside of EZ unless operator is in "HANDS OFF" mode.			
2. Assembly of concrete forms (i.e. plywood, lumber, rebar, etc.)	<b>2a. CONTACT:</b> Contacting materials being lowered into work area. Potential for cuts and abrasions and to be contacted by nails while assembling.  <b>2b. EXERTION:</b> Muscle strain.  <b>2c. EXPOSURE:</b> Noise, dust, fumes.  <b>2d. CAUGHT:</b> Pinch points, caught between, Crushed	2a. Workers will keep fingers and limbs out of the line of fire of tools, equipment and live loads. Workers will use inspected rigging and only attach rigging to manufacturer installed lifting points. Loads will be controlled with non-conductive tag lines from outside the EZ. Wear hard hat. See JSA for applicable cutting tool.  2b. When transporting and working with forms, workers will keep backs straight, knees bent, and loads close to their body. Any load more than 50 lbs., will be lifted by two or more workers or a mechanical lifting device.  2c. Workers will wear hearing protection, face shields and chaps when using all power tools. Fuel powered tools will be fueled away from the work zone in a well-ventilated area. Refueling will be done after a minimum cool down period of 5 minutes. See JSA for applicable cutting tool.  2d. Keep hands away from rigging while hooking/unhooking materials; wear cut resistant gloves.			
3. Setup concrete trucks and chute	<b>3a. CONTACT/CAUGHT:</b> Potential for truck to contact personnel, fingers to be pinched while setting up chutes. Contact with overhead power lines.  <b>3b. OVEREXERTION:</b> Strain, pulled muscles.	3a. Spotters will guide concrete trucks into position; wheel chocks will be set before work begins when trucks are parked. Workers will stay out of exclusion zone until truck is parked and secured. Keep hands clear of potential pinch points when assembling chutes.  3a. A minimum clearance of 10 feet shall be maintained from all overhead power lines. That distance may be reduced if shielding is in place or it is determined that lines are low voltage.  3b. All workers will keep back straight and bend their knees when lifting. Two workers will be used when load exceeds 50 lbs.			

<sup>1</sup> Each Job or Operation consists of a set of tasks / steps. Be sure to list all the steps needed to perform job.

<sup>2</sup> A hazard is a potential danger. Break hazards into six types: Contact - victim is struck by or strikes an object; Caught - victim is caught on, caught in or caught between objects; Fall - victim falls to ground or lower level (includes slips and trips); Exertion - excessive strain or stress / ergonomics / lifting techniques; Exposure - inhalation/skin hazards; Energy Source - electricity, pressure, compression/tension.

<sup>3</sup> Using the first two columns as a guide, decide what actions or procedures are necessary to eliminate or minimize the risk. List the recommended safe operating procedures. Say exactly what needs to be done - such as "use two persons to lift". Avoid general statements such as, "be careful".

Assess 1JOB STEPS	Analyze 2POTENTIAL HAZARDS	Act 3CRITICAL ACTIONS
4. Pour concrete into forms	<p><b>4a. CONTACT:</b> Splashing from wet concrete.</p> <p><b>4b. EXPOSURE:</b> Concrete dust.</p>	<p>4a. Portable eye wash stations shall be set up nearby for easy access; wear safety glasses. Nitrile or latex gloves and water proof boots or boot covers shall be worn to eliminate skin contact with concrete. Any concrete splashed onto non-waterproof clothing shall be removed to avoid skin irritation.</p> <p>4b. Stand upwind while mixing dry concrete. Use dust mask or air purifying respirator to avoid silica inhalation.</p>
5. Concrete finishing work with hand tools and/or vibrate to settle and remove air from poured cement,	<p><b>5a. ENERGY SOURCE:</b> Potential for personnel to be exposed to live electricity.</p> <p><b>5b. OVEREXERTION:</b> Potential muscle strain while vibrating cement, stepping over forms/rebar reinforcements.  During use of hand tools to finish concrete, worker can overextend to reach far end of poured area.</p> <p><b>5c. CONTACT:</b> Potential hand tools with extension poles/handles to contact nearby workers/pedestrians/vehicles/overhead power lines.</p>	<p>5a. Electrical tools shall be inspected for defects prior to being used. Any extension cords shall be heavy duty rated and be free from defects (no exposed wires). All electrical connections shall be connected to GFCI outlets. Generators shall be run in well ventilated locations.</p> <p>5b. Constantly check/observe where you are walking; wear steel toed boots. Keep back straight and knees bent while settling concrete with vibrator.</p> <p>5b. If worker needs to reach the far end of a poured area with finishing tools, they shall use extension poles and not over reach to maintain balance. Maintain even footing while using finishing tools. Use spotter during extension pole use.</p> <p>5c. During use of hand tools to finish poured concrete workers will alert work crew. If utilizing extension poles/handles worker will use a spotter to make sure no contact is made with other workers, pedestrians, vehicles or overhead power lines.</p>
6. Cleanup of work area and tools.	<b>6a. CONTACT/FALL:</b> Potential slip, trip, and fall on materials and tools left in the work area.	6a. Place additional materials and tools in designated storage areas. Remove any garbage from the work area.

<sup>1</sup> Each Job or Operation consists of a set of tasks / steps. Be sure to list all the steps needed to perform job.

<sup>2</sup> A hazard is a potential danger. Break hazards into six types: Contact - victim is struck by or strikes an object; Caught - victim is caught on, caught in or caught between objects; Fall - victim falls to ground or lower level (includes slips and trips); Exertion - excessive strain or stress / ergonomics / lifting techniques; Exposure - inhalation/skin hazards; Energy Source – electricity, pressure, compression/tension.

<sup>3</sup> Using the first two columns as a guide, decide what actions or procedures are necessary to eliminate or minimize the risk. List the recommended safe operating procedures. Say exactly what needs to be done - such as "use two persons to lift". Avoid general statements such as, "be careful".



JOB SAFETY ANALYSIS		Ctrl. No. GEN-005	DATE 8/6/2018	<input type="checkbox"/> NEW <input checked="" type="checkbox"/> REVISED	PAGE 1 of 2
JSA TYPE CATEGORY <b>GENERIC</b>	WORK TYPE <b>Construction</b>	WORK ACTIVITY (Description) <b>Cutting with Gas-powered Saw, Sawzall or Plasma Cutter</b>			
<b>DEVELOPMENT TEAM</b>	<b>POSITION / TITLE</b>	<b>REVIEWED BY:</b>	<b>POSITION / TITLE</b>		
Ray Greenidge	Office Health and Safety Manager	Brian Hobbs	Corporate Health & Safety Manager		
<b>REQUIRED AND / OR RECOMMENDED PERSONAL PROTECTIVE EQUIPMENT</b>					
<input checked="" type="checkbox"/> REFLECTIVE VEST <input checked="" type="checkbox"/> HARD HAT <input type="checkbox"/> LIFELINE / BODY HARNESS <input checked="" type="checkbox"/> SAFETY GLASSES	<input type="checkbox"/> GOGGLES <input checked="" type="checkbox"/> FACE SHIELD (gas powered saw and plasma cutter) <input checked="" type="checkbox"/> HEARING PROTECTION <input checked="" type="checkbox"/> SAFETY SHOES: <u>Steel-toed boots</u>	<input type="checkbox"/> AIR PURIFYING RESPIRATOR <input type="checkbox"/> SUPPLIED RESPIRATOR <input checked="" type="checkbox"/> PPE CLOTHING: <u>Fluorescent Long sleeved shirt and / or reflective safety vest</u>	<input checked="" type="checkbox"/> GLOVES: <u>Cut-resistant, leather, nitrile</u> <input checked="" type="checkbox"/> OTHER: Chaps for gas powered saw. Welding suit for plasma cutting.		
<b>REQUIRED AND / OR RECOMMENDED EQUIPMENT</b>					
Sawzall/extension cord					
<b>COMMITMENT TO SAFETY-</b> All personnel onsite will actively participate in hazard recognition and mitigation throughout the day by verbalizing SPSAs					
<b>Assess 1JOB STEPS</b>	<b>Analyze 2POTENTIAL HAZARDS</b>	<b>Act 3CRITICAL ACTIONS</b>			
1. Set up/ Secure work area.	1a. <b>CONTACT:</b> Personnel could enter the work area	1a. Establish the work zone using 42" cones, caution tape, or fixed rigid barrier. Inform others of work activity.			
2. Precutting procedure.	2a. <b>CONTACT:</b> Improper blade, malfunctioning guards, unsecured materials, flying debris  2b. <b>EXPOSURE:</b> Loud noises, dust, bright UV light  2c. <b>ENERGY SOURCE:</b> Potential for electric shock	2a. Inspect all equipment for defects, replace or service if not functioning optimally. Check that all guards are working and in place, replace if missing. Ensure that blades are sharp and clean to avoid binding and/or burning. Cut on flat/secure work surfaces. Do not cut badly warped wood or boards with knots or nails.  2a. Unplug saw before handing it off to another person.  2a. Wear safety glasses, long-sleeved shirt and leather gloves. Utilize job specific PPE such as welding jacket or chaps when using gas powered saw or a plasma cutter.  2b. When using gas powered saw, wet down area to be cut prior to cutting if high dust levels are anticipated.  2b. Wear hearing protection. Wear a dust mask if large amounts of dust are expected; cut upwind if possible.  2b. When plasma cutting, wear a face shield with shaded glasses rated to block UV light generated by the plasma cutter.  2c. Inspect extension cord for damage. If damaged, tag out and repair / replace. Do not operate saw while standing in water. Ensure GFCI protection at outlet or via attachment.  2c. Ensure all electrical equipment is rated for the task.			

<sup>1</sup> Each Job or Operation consists of a set of tasks / steps. Be sure to list all the steps needed to perform job.

<sup>2</sup> A hazard is a potential danger. Break hazards into six types: Contact - victim is struck by or strikes an object; Caught - victim is caught on, caught in or caught between objects; Fall - victim falls to ground or lower level (includes slips and trips); Exertion - excessive strain or stress / ergonomics / lifting techniques; Exposure - inhalation/skin hazards; Energy Source - electricity, pressure, compression/tension.

<sup>3</sup> Using the first two columns as a guide, decide what actions or procedures are necessary to eliminate or minimize the risk. List the recommended safe operating procedures. Say exactly what needs to be done - such as "use two persons to lift". Avoid general statements such as, "be careful".

Assess 1JOB STEPS	Analyze 2POTENTIAL HAZARDS	Act 3CRITICAL ACTIONS
3. Saw Cutting.	<p><b>3a. CONTACT:</b> Fingers could be cut, lacerated or amputated by reciprocating blade; also flying debris and sparks</p> <p><b>3b. CONTACT:</b> Amputation and line of fire injury.</p> <p><b>3c. FALL:</b> Tripping hazards caused by cutting/grinding debris, extension cords.</p> <p><b>3d. EXERTION/ERGONOMICS:</b> Lifting heavy or awkward materials may cause muscle strain.</p> <p><b>3e. EXPOSURE:</b> Personnel may be exposed to fire hazard during Hot Work Activities.</p>	<p>3a. Cut away from body. Keep fingers away from moving blade. No loose clothing. Never leave saw running unattended. Unplug saw before changing blades or making adjustments / repairs. Set-up barrier to contain sparks. Cut on flat/secure work surfaces.</p> <p>3a. Wear Safety glasses</p> <p>3a. Ensure that the saw blade stops rotating/reciprocating before placing saw on the ground.</p> <p>3b. Maintain a minimum 15-foot exclusion zone and ensure that operator and other personnel are kept out of the line-of- fire of the equipment.</p> <p>3c. Keep debris generated in designated storage containers. Keep work area free of Slip, Trip and Fall hazards.</p> <p>3c. Do not route extension cords through walking/working path.</p> <p>3d. Maintain Proper Body Position while operating lifting and moving with equipment. Keep load close to body, knees bent, and back straight.</p> <p>3d. Take frequent breaks or switch personnel if cutting for an extended period of time.</p> <p>3e. Complete Hot Work Permit, Designate Fire Watch.</p> <p>3e. Conduct work zone inspection:</p> <ul style="list-style-type: none"> <li>- Verify that all combustible or flammable materials or equipment fuel sources have been removed from within 35 feet of the proposed hot work.</li> <li>- If combustible or flammable materials or equipment fuel sources have not been removed from within 35 feet of the hot work, verify that engineering and procedural controls have been emplaced: curtains, blankets, wetting, ventilation.</li> </ul> <p>3e. Two 20-lb. Type ABC Fire extinguishers required.</p> <p>3e. Conduct continuous air monitoring / Lower Explosive Limit (LEL) screenings. Action Level: 10% of the LEL.</p> <p>3e. If ambient air concentrations exceed LEL Action Levels, STOP WORK and contact supervisor.</p> <p>3e. Wear hard hat, long sleeved-shirt and safety glasses. Utilize job specific PPE such as welding jacket or chaps and welding glasses when using gas powered saw or a plasma cutter.</p>
4. Secure area when leaving tools unattended.	<p><b>4a. CONTACT:</b> Unauthorized personnel may enter the work area</p> <p><b>4b. FALL:</b> Slip/trip/fall</p>	<p>4a. Unplug saw when not being used. Store equipment in designated storage areas when not being used.</p> <p>4b. Store tool in designated storage location when it is not being used, secure all extension cords, keep all equipment out of walkways.</p> <p>4b. Keep work area free of Slip, Trip and Fall Hazards.</p>

<sup>1</sup> Each Job or Operation consists of a set of tasks / steps. Be sure to list all the steps needed to perform job.

<sup>2</sup> A hazard is a potential danger. Break hazards into six types: Contact - victim is struck by or strikes an object;

Caught - victim is caught on, caught in or caught between objects; Fall - victim falls to ground or lower level (includes slips and trips); Exertion - excessive strain or stress / ergonomics / lifting techniques; Exposure - inhalation/skin hazards; Energy Source – electricity, pressure, compression/tension.

<sup>3</sup> Using the first two columns as a guide, decide what actions or procedures are necessary to eliminate or minimize the risk. List the recommended safe operating procedures. Say exactly what needs to be done - such as "use two persons to lift". Avoid general statements such as, "be careful".

<b>JOB SAFETY ANALYSIS</b> Ctrl. No. GEN-006		DATE 8/6/2018	<input type="checkbox"/> NEW <input checked="" type="checkbox"/> REVISED	PAGE 1 of 2
JSA TYPE CATEGORY: <b>Generic</b>		WORK TYPE: <b>Drilling</b>	WORK ACTIVITY (Description): <b>Direct Push Soil Borings / Well Installation</b>	
<b>DEVELOPMENT TEAM</b>		<b>POSITION / TITLE</b>	<b>REVIEWED BY:</b>	<b>POSITION / TITLE</b>
Timothy Zei		Project Hydrogeologist	Raymond Olson	Staff Assistant Geologist
			Christine Pietrzyk	Office Health & Safety Manager
			Brian Hobbs	Corporate Health & Safety Manager
<b>REQUIRED AND / OR RECOMMENDED PERSONAL PROTECTIVE EQUIPMENT</b>				
<input type="checkbox"/> LIFE VEST <input checked="" type="checkbox"/> HARD HAT <input type="checkbox"/> LIFELINE / BODY HARNESS <input checked="" type="checkbox"/> SAFETY GLASSES	<input type="checkbox"/> GOGGLES <input type="checkbox"/> FACE SHIELD <input checked="" type="checkbox"/> HEARING PROTECTION: (as needed) <input checked="" type="checkbox"/> SAFETY SHOES: <u>Composite-toe or steel toe boots</u>	<input type="checkbox"/> AIR PURIFYING RESPIRATOR <input type="checkbox"/> SUPPLIED RESPIRATOR <input checked="" type="checkbox"/> PPE CLOTHING: <u>Fluorescent reflective vest or high visibility clothing, Long Sleeve Shirt</u>	<input checked="" type="checkbox"/> GLOVES: <u>Leather, Nitrile and cut resistant</u> <input checked="" type="checkbox"/> OTHER: <u>Insect Repellent, sunscreen (as needed)</u>	
<b>REQUIRED AND / OR RECOMMENDED EQUIPMENT</b>				
Geoprobe or Truck-Mounted Direct Push Drill Rig, Hand Tools, Photoionization Detector, Multi-Gas Meter (or equivalent), Macrocore liners, Liner Opening Tool, 20 lb. Type ABC Fire Extinguisher, 42" Cones & Flags, "Work Area" Signs, Water				
<b>COMMITMENT TO SAFETY-</b> All personnel onsite will actively participate in hazard recognition and mitigation throughout the day by verbalizing SPSAs				
<b>EXCLUSION ZONE (EZ) – All non-essential personnel will maintain a distance of 10 feet from drilling equipment while equipment is moving/engaged</b>				
<b>"SHOW ME YOUR HANDS"</b>				
<b>Driller and helper should show that hands are clear from controls and moving parts</b>				
<b>Assess JOB STEPS</b>	<b>Analyze POTENTIAL HAZARDS</b>	<b>Act CRITICAL ACTIONS</b>		
1. Mobilization of drilling rig (ensure the Subsurface Clearance Protocol and Drill Rig Checklist are completed)	1a. <b>CONTACT:</b> Equipment/property damage.  1b. <b>FALL:</b> Slip/trip/fall hazards.  1c. <b>CONTACT:</b> Crushing from roll-over.	1a. The drill rig's tower/derrick will be lowered and secured prior to mobilization. 1a. A spotter should be utilized while moving the drill rig. If personnel move into the path of the drill rig, the drill rig will be stopped until the path is again clear. Use a spotter for all required backing operations. 1a. Set-up the work area and position equipment in a manner that eliminates or reduces the need for backing of support trucks and trailers. 1a. When backing up truck with an attached trailer use a second spotter if there is tight clearance simultaneously on multiple sides of the equipment or if turning angles limit driver visibility. 1a. Inspect the driving path for uneven terrain. Level or avoid if needed. 1a. Drill rig should have a minimum <b>exclusion zone of 10 feet</b> for non-essential personnel (i.e., driller helper, geologist) when the rig is moving/ in operation.  1b. Inspect walking path for uneven terrain, weather-related hazards (i.e., ice, puddles, snow, etc.), and obstructions prior to mobilizing equipment. 1b. Do not climb over stored materials/equipment; walk around. Practice good housekeeping. 1b. Use established pathways and walk on stable, secure ground. 1c Geoprobe should cross all hills/obstructions head on with the mast down to reduce risk of roll-over.		
2. Raising tower/derrick of drill rig	2a. <b>CONTACT:</b> Overhead hazards.  2b. <b>CONTACT:</b> Pinch Points/Amputation Points when raising the rig and instability of rig	2a. Prior to raising the tower/derrick, the area above the drilling rig will be inspected for wires, tree limbs, piping, or other structures, that could come in contact with the rig's tower and/or drilling rods or tools. 2a. Maintain a safe distance of 10' from overhead structures.  2b. Inspect the equipment prior to use and avoid pinch/amputation points. 2b. Lower outriggers to ensure stability prior to raising rig tower/derrick. 2b. If the rig needs to be mounted, be sure to use three points of contact.		
3. Advancement of drilling equipment and well installation	3a. <b>CONTACT:</b> Flying debris  3b. <b>EXPOSURE:</b> Noise and dust.	3a. Be aware of and avoid potential lines of fire and wear required PPE such as eye, ear, and hand protection.  3b. Wet borehole area with sprayer to minimize dust. 3b. Stand upwind and keep body away from rig. 3b. Dust mask should be worn if conditions warrant. 3b. Wear hearing protection when the drill rig is in operation.		

<sup>1</sup> Each Job or Operation consists of a set of tasks / steps. Be sure to list all the steps needed to perform job.

<sup>2</sup> A hazard is a potential danger. Break hazards into six types: Contact - victim is struck by or strikes an object; Caught - victim is caught on, caught in or caught between objects; Fall - victim falls to ground or lower level (includes slips and trips); Exertion - excessive strain or stress / ergonomics / lifting techniques; Exposure - inhalation/skin hazards; Energy Source - electricity, pressure, compression/tension.

<sup>3</sup> Using the first two columns as a guide, decide what actions or procedures are necessary to eliminate or minimize the risk. List the recommended safe operating procedures. Say exactly what needs to be done - such as "use two persons to lift". Avoid general statements such as, "be careful".

Assess 1JOB STEPS	Analyze 2POTENTIAL HAZARDS	Act 3CRITICAL ACTIONS
3. Advancement of drilling equipment and well installation (Continued)	<p><b>3a. CONTACT:</b> Flying debris</p> <p><b>3b. EXPOSURE:</b> Noise and dust.</p> <p><b>3c. FALL:</b> Slip/trip/fall hazards.</p> <p><b>3d. CAUGHT:</b> Limb/extremity pinching; abrasion/crushing.</p> <p><b>3e. CONTACT:</b> Equipment imbalance during advancement of drill equipment.</p> <p><b>3f. EXPOSURE:</b> Inhalation of contamination/vapors.</p> <p><b>3g. EXERTION:</b> Potential for muscle strain/injury while lifting and installing well casings, lifting sand bags, and/or lifting rods.</p>	<p>3c. Contain drill cuttings and drilling water to prevent fall hazards from developing in work area.</p> <p>3c. See 1b.</p> <p>3d. Ensure all Emergency Safety Stop buttons function properly.</p> <p>3d. Always wear leather gloves when making connections and using hand tools; wear cut-resistant (i.e., Kevlar) gloves when handling cutting tools.</p> <p>3d. Inspect the equipment prior to use for potential pinch/amputation points. Keep hands away from pinch/amputation points and use of tools is preferable compared to fingers and hands.</p> <p>3d. Inspect drill head for worn surface or missing teeth; replace if damaged or blunt.</p> <p>3d. Ensure all jewelry is removed, loose clothing is secured, and PPE is secured close to the body.</p> <p>3d. All non-essential personnel should stay away from the immediate work area; position body out of the line-of-fire of equipment.</p> <p>3d. Drillers and helpers will understand and use the "Show Me Your Hands" Policy.</p> <p>3d. Spinning rods/casing have an <b>exclusion zone of 10 feet</b> while in operation.</p> <p>3e. Drillers will advance the borehole with caution to avoid causing the rig to become imbalanced and/or tip.</p> <p>3e. The blocking and leveling devices used to secure the rig will be inspected by drillers and Roux personnel regularly to see if shifting has occurred.</p> <p>3e. In addition, personnel and equipment that are non-essential to the advancement of the borehole will be positioned away from the rig at a distance that is at least as far as the boom is high (<b>minimum exclusion zone of 10 feet</b>).</p> <p>3f. Monitor ambient air for dangerous conditions using a calibrated photoionization detector (PID) to periodically monitor the breathing zone of the work area.</p> <p>3f. If a reading of &gt;5ppm is recorded, the Roux field personnel must temporarily cease work, instruct all Site personnel to step away from the area of elevated readings and inform the Roux PM of the condition. The Roux PM will then recommend additional precautions in accordance with the site specific health and safety plan.</p> <p>3f. Use a multi-gas meter to monitor ambient air for dangerous conditions (i.e. unsafe levels of carbon monoxide when drilling indoors or the presence of explosive vapors).</p> <p>3g. Keep back straight and bend at the knees.</p> <p>3g. Utilize team lifting for objects over 50lbs.</p> <p>3g. Use mechanical lifting device for odd shaped objects.</p>
4. Remove sample liner.	<p><b>4a. EXERTION:</b> Potential for muscle strain/injury while removing liner from probe rod.</p> <p><b>4b. CONTACT:</b> Pinch points and cuts</p> <p><b>4c. EXPOSURE:</b> Inhalation and/or dermal contact with contaminants.</p>	<p>4a. Utilize team lifting for objects over 50lbs.</p> <p>4a. Use hydraulic liner extruder if available.</p> <p>4b. Place liner on sturdy surface when opening.</p> <p>4b. Don cut-resistant gloves and use appropriate liner cutter when opening liners.</p> <p>4b. Always cut away from the body.</p> <p>4c. Wear chemical-resistant disposable gloves when handling liners.</p> <p>4c. See 3e.</p>
5. Decontaminate equipment.	<p><b>5a. EXPOSURE/CONTACT:</b> To contamination (e.g., Separate Phase Hydrocarbons (SPH), contaminated groundwater, vapors).</p> <p><b>5b. EXPOSURE:</b> To chemicals in cleaning solution including ammonia.</p>	<p>5a. Wear chemical-resistant disposable gloves and safety glasses.</p> <p>5a. Contain decontamination water so that it does not spill.</p> <p>5a. Use an absorbent pad to clean spills, if necessary.</p> <p>5a. Spray equipment from side angle, not straight on, to avoid backsplash.</p> <p>5a. See 3b.</p> <p>5b. See 4a. Review SDS to ensure appropriate precautions are taken and understood.</p>

<sup>1</sup> Each Job or Operation consists of a set of tasks / steps. Be sure to list all the steps needed to perform job.

<sup>2</sup> A hazard is a potential danger. Break hazards into six types: Contact - victim is struck by or strikes an object;

Caught - victim is caught on, caught in or caught between objects; Fall - victim falls to ground or lower level (includes slips and trips); Exertion - excessive strain or stress / ergonomics / lifting techniques; Exposure - inhalation/skin hazards; Energy Source – electricity, pressure, compression/tension.

<sup>3</sup> Using the first two columns as a guide, decide what actions or procedures are necessary to eliminate or minimize the risk. List the recommended safe operating procedures. Say exactly what needs to be done - such as "use two persons to lift". Avoid general statements such as, "be careful".

<b>JOB SAFETY ANALYSIS</b>		<b>Ctrl. No. GEN-007</b>	DATE 8/6/2018	<input type="checkbox"/> NEW <input checked="" type="checkbox"/> REVISED	PAGE 1 of 2
JSA TYPE CATEGORY <b>GENERIC</b>	WORK TYPE <b>General Site Activity</b>	WORK ACTIVITY (Description) <b>Driving</b>			
<b>DEVELOPMENT TEAM</b>	<b>POSITION / TITLE</b>	<b>REVIEWED BY:</b>		<b>POSITION / TITLE</b>	
Valerie Sabatasso	Staff Scientist	Brian Hobbs		Corporate Health & Safety Manager	
<b>REQUIRED AND / OR RECOMMENDED PERSONAL PROTECTIVE EQUIPMENT</b>					
<input type="checkbox"/> LIFE VEST <input checked="" type="checkbox"/> HARD HAT: <u>when outside vehicle</u> <input type="checkbox"/> LIFELINE / BODY HARNESS <input checked="" type="checkbox"/> SAFETY GLASSES: <u>when outside vehicle</u>	<input type="checkbox"/> GOGGLES <input type="checkbox"/> FACE SHIELD <input checked="" type="checkbox"/> HEARING PROTECTION <input checked="" type="checkbox"/> SAFETY TOE BOOTS: <u>when outside vehicle</u>	<input type="checkbox"/> AIR PURIFYING RESPIRATOR <input type="checkbox"/> SUPPLIED RESPIRATOR <input checked="" type="checkbox"/> PPE CLOTHING: <u>high visibility vest, when outside vehicle</u>	<input checked="" type="checkbox"/> GLOVES: <u>Leather/ cut-resistant level 2</u> <input type="checkbox"/> OTHER _____		
<b>REQUIRED AND / OR RECOMMENDED EQUIPMENT</b>					
Motor Vehicle (i.e. car, truck, SUV)					
<b>COMMITMENT TO SAFETY-</b> All personnel onsite will actively participate in hazard recognition and mitigation throughout the day by verbalizing SPSAs					
<b>EXCLUSION ZONE: A 10' minimum exclusion zone will be maintained around motor vehicles when operating.</b>					
<b>Assess JOB STEPS</b>	<b>Analyze POTENTIAL HAZARDS</b>	<b>Act CRITICAL ACTIONS</b>			
1. Driving to/leaving Site	<p><b>1a. CONTACT:</b> Severe injury/disability, property damage, monetary loss (insurance premiums, deductibles, loss of license/job) caused by collision with or struck by other vehicles, obstructions, pedestrians, animals, etc.</p> <p>*Common factors that may lead to CONTACT incident, but not limited to:</p> <ul style="list-style-type: none"> <li>• distracted driving (cell phone, GPS, radio, billboards, "rubber necking")</li> <li>• lack of situational awareness</li> <li>• unfamiliarity with traffic patterns/road layout</li> <li>• weather conditions (wet/icy roads, hydroplaning, black ice)</li> <li>• weariness</li> <li>• high speeds</li> <li>• obstructed vision (solar glare, debris on windshield, blind spots)</li> <li>• changes in travel pathway (construction, snow banks, non-operational signals, potholes, detours, special events)</li> <li>• improper vehicle maintenance (non-operational signal light, worn tires, cracked windshield, ineffective wipers)</li> <li>• loose or unsecure objects</li> </ul>	<p>1a. PLAN AHEAD – review/make yourself familiar with maps and driving directions before beginning the drive to the Site. Do not attempt to drive and review maps/directions at the same time. Pull over and stop your vehicle before looking at maps/directions.</p> <p>1a. Complete a basic vehicle inspection before driving. Verify Inspection and Registration are current, tires and wipers are in good condition, all lights are functional, all glass/mirrors are undamaged, the horn is functional, roof/hood/trunk are free from accumulated snow and visibility is not impaired due to snow/ice/frost/fog on windows.</p> <p>1a. Do not hang items in car that can obstruct your view or become projectiles in a collision.</p> <p>1a. Do not get distracted using touch screen radios or GPS units built into newer models. Keep your eyes on the road and stay alert.</p> <p>1a. Follow posted speed limits and obey traffic signals and roadway signs.</p> <p>1a. Always wear your seat belt and shoulder harness when driving.</p> <p>1a. When driving around large vehicles and trucks, maintain extra space as these vehicles may not be able to see a smaller car too close.</p> <p>1a. Follow the "Rules of the Road" including: using your turn signals, coming to a complete stop, and allowing vehicles the right of way (yield) when they are when traffic laws require.</p> <p>1a. Apply the Smith Five Keys® of safe driving</p> <ul style="list-style-type: none"> <li>• Aim High in Steering® <ul style="list-style-type: none"> <li>- Expand eye lead time to a minimum of 15 seconds</li> </ul> </li> <li>• Get the Big Picture® <ul style="list-style-type: none"> <li>- Maintain proper a 4 second minimum following distance at all times</li> <li>- Scan mirrors every 5-8 seconds to achieve a circle of awareness</li> <li>- Position your vehicle so you can see relevant/non-relevant objects</li> </ul> </li> <li>• Keep Your Eyes Moving® <ul style="list-style-type: none"> <li>- Try to maintain about 180 degrees of visibility</li> <li>- Avoid blank and fixed stares. Avoid focusing on one object for more than 2 seconds</li> </ul> </li> <li>• Leave Yourself an Out® <ul style="list-style-type: none"> <li>- Avoid traveling in traffic clusters</li> <li>- Surround yourself with space</li> <li>- Anticipate the actions of others</li> </ul> </li> </ul>			

<sup>1</sup> Each Job or Operation consists of a set of tasks / steps. Be sure to list all the steps needed to perform job.

<sup>2</sup> A hazard is a potential danger. Break hazards into six types: Contact - victim is struck by or strikes an object; Caught - victim is caught on, caught in or caught between objects; Fall - victim falls to ground or lower level (includes slips and trips); Exertion - excessive strain or stress / ergonomics / lifting techniques; Exposure - inhalation/skin hazards; Energy Source – electricity, pressure, compression/tension.

<sup>3</sup> Using the first two columns as a guide, decide what actions or procedures are necessary to eliminate or minimize the risk. List the recommended safe operating procedures. Say exactly what needs to be done - such as "use two persons to lift". Avoid general statements such as, "be careful".

Assess 1 JOB STEPS	Analyze 2 POTENTIAL HAZARDS	Act 3 CRITICAL ACTIONS
1. Driving to/leaving Site (cont'd)	<p><b>1a. CONTACT:</b> Severe injury/disability, property damage, monetary loss (insurance premiums, deductibles, loss of license/job) caused by collision with or struck by other vehicles, obstructions, pedestrians, animals, etc.</p>	<ul style="list-style-type: none"> <li>• Make Sure They See You® <ul style="list-style-type: none"> <li>- Maintain eye contact with on-coming vehicles/pedestrians</li> <li>- Use warning devices (e.g., hand signals, high-lights, horns etc.)</li> <li>- Proper timing is essential</li> </ul> </li> </ul> <p>1a. Do not perform reconnaissance or inspections while driving. Your vehicle should be parked in a safe location when viewing or surveying the Site and vicinity</p> <p>1a. Avoid sudden turns and stops. Don't drive recklessly – be in control of vehicle at all times.</p> <p>1a. In inclement weather, first determine if work can be POSTPONED. Otherwise, plan according to weather conditions including checking forecast along entirety of travel route (especially, for long distances). Reduce speed as road conditions warrant. Travelling with winter car equipment, in the winter, is strongly recommended (i.e., shovel, scraper, brush, blanket, extra clothing, flashlight, bag of sand). If your vehicle has 4-wheel drive, review to operators manual and understand operating procedure prior to engaging 4-wheel drive. If at any point on your drive weather becomes too severe to proceed safely pull over if safe to do so or seek nearest cover (e.g., overpass)</p> <p>1a. If feeling drowsy or sleepy, do not drive. Pull over in a safe place to rest if you experience any signs of drowsiness. Make sure to get adequate sleep the night before an early drive.</p> <p>1a. Never operate a vehicle under the influence of alcohol or illegal substances or medications affecting your performance.</p> <p>1a. Keep your eyes on the road. Do not call or talk on cellular phones. Pull over to a safe location if you must answer or make a call. (Legal requirement in: CA, CT, DE, D.C., HI, IL, LA*, MD, NV, NH*, NJ, NM, NY, OK*, OR, TX*, VT, WA, WV as of 01/20/15; per <a href="http://www.IIHS.org">www.IIHS.org</a>)</p> <p>* = Applicable to some drivers, situations or to be implemented in 2015</p> <p>1a. When parking, pull-through when possible. If backing is required visually inspect area to ensure it is free from obstructions prior to backing in and relying solely on mirrors; use spotters when available.</p>
2. Entering/Exiting Vehicle.	<p><b>2a. CAUGHT:</b> Personal injury (broken fingers/hand) while entering or exiting vehicles</p> <p><b>2b. FALL:</b> Personal injury (twisted ankle, deep contusion, concussion, broken wrist/arm, etc.) from slip/fall on uneven or unstable or slippery surface while exiting/entering vehicle</p> <p><b>2c. CONTACT:</b> Severe injury/disability, property damage, monetary loss (insurance premiums, deductibles, loss of license/job) caused by collision with or struck by other vehicles, obstructions, pedestrians, animals, etc.</p>	<p>2a. Open and close doors slowly. Never put hands or feet in between door and vehicle to avoid pinch points.</p> <p>2b. When exiting the vehicle make sure your feet are on firm footing and weight is evenly distributed before exiting/standing. In inclement weather use hands to support yourself, by holding the car door and/or steering wheel, when exiting the vehicle.</p> <p>2c. Check both directions for traffic before opening door. Do not exit vehicle if traffic does not permit you to exit safely</p> <p>2c. Check anticipated path of door prior to opening, do not open door into any obstructions (e.g., bollards, high curbing)</p>

<sup>1</sup> Each Job or Operation consists of a set of tasks / steps. Be sure to list all the steps needed to perform job.

<sup>2</sup> A hazard is a potential danger. Break hazards into six types: Contact - victim is struck by or strikes an object; Caught - victim is caught on, caught in or caught between objects; Fall - victim falls to ground or lower level (includes slips and trips); Exertion - excessive strain or stress / ergonomics / lifting techniques; Exposure - inhalation/skin hazards; Energy Source – electricity, pressure, compression/tension.

<sup>3</sup> Using the first two columns as a guide, decide what actions or procedures are necessary to eliminate or minimize the risk. List the recommended safe operating procedures. Say exactly what needs to be done - such as "use two persons to lift". Avoid general statements such as, "be careful".

<b>JOB SAFETY ANALYSIS</b>		<b>Ctrl. No. GEN-010</b>	DATE 7/6/2020	<input type="checkbox"/> NEW <input checked="" type="checkbox"/> REVISED	PAGE 1 of 2
JSA TYPE CATEGORY <b>Generic</b>		WORK TYPE <b>Surveying</b>	WORK ACTIVITY (Description) <b>Elevation Surveying</b>		
<b>DEVELOPMENT TEAM</b>		<b>POSITION / TITLE</b>	<b>REVIEWED BY:</b>	<b>POSITION / TITLE</b>	
Mark M Emmons		Project Engineer	Brian Hobbs	Corporate Health & Safety Manager	
Bjorn Wespestad		Senior Engineer			
William Hansen		Senior Engineer			
<b>REQUIRED AND / OR RECOMMENDED PERSONAL PROTECTIVE EQUIPMENT</b>					
<input type="checkbox"/> LIFE VEST <input checked="" type="checkbox"/> HARD HAT <input type="checkbox"/> LIFELINE / BODY HARNESS <input checked="" type="checkbox"/> SAFETY GLASSES	<input type="checkbox"/> GOGGLES <input type="checkbox"/> FACE SHIELD <input type="checkbox"/> HEARING PROTECTION <input checked="" type="checkbox"/> SAFETY SHOES: <u>Steel-toe boots</u>	<input type="checkbox"/> AIR PURIFYING RESPIRATOR <input type="checkbox"/> SUPPLIED RESPIRATOR <input checked="" type="checkbox"/> PPE CLOTHING: <u>Fluorescent reflective vest or high visibility clothing</u>	<input checked="" type="checkbox"/> GLOVES: <u>Cut-resistant or leather</u> <input checked="" type="checkbox"/> OTHER: <u>Long sleeve Shirt</u>		
<b>REQUIRED AND / OR RECOMMENDED EQUIPMENT</b>					
Surveying equipment (i.e., leveling rod/measuring ruler, tripod and autolevel).					
<b>COMMITMENT TO SAFETY</b> - All personnel onsite will actively participate in hazard recognition and mitigation throughout the day by verbalizing SPSAs.					
<b>Assess 1JOB STEPS</b>		<b>Analyze 2POTENTIAL HAZARDS</b>		<b>Act 3CRITICAL ACTIONS</b>	
1. Check in with Site manager/ property owner.		1a. <b>CONTACT/EXPOSURE/FALL:</b> Lack of communication could result in H&S incident.		1a. Inform Site personnel of work scope, timeline and location(s). 1a. Inquire about other activities taking place at the Site. 1a. If applicable, obtain General Work permit for the day.	
2. Locate surveying position for instrument and rod and set-up work area		2a. <b>FALL:</b> Slip/trip hazards  2b. <b>CONTACT:</b> Traffic (surveying locations could potentially be in parking areas and sidewalks)  2c. <b>OVEREXERTION:</b> Hazard due to carrying, lifting, and bending while transporting equipment  2d. <b>CAUGHT/CONTACT:</b> Pinch Points / sharp edges associated with setting up the tripod  2e. <b>OVEREXERTION:</b> Hazard due to bending awkwardly to look through the autolevel		2a. Inspect area for uneven terrain, weather-related hazards (i.e., ice, puddles, snow, etc.) and obstructions prior to setting up at the survey location. Keep eyes engaged with walking surface while in movement. Remember "Walking is Working." 2a. Conduct housekeeping and maintain clear paths to walk in and remove debris as required. 2b. Be aware of oncoming traffic. Utilize a flagman / spotter for locations in streets or high-traffic areas. 2b. Place 42 inch cones around the work area and delineate work zone with caution tape, snow fencing or safety bars, if necessary. 2b. Wear appropriate PPE including long sleeve high visibility clothing and or reflective safety vest. 2b. Face traffic, maintain eye contact with oncoming vehicles and establish a safe exit route. 2c. Use proper body positioning and lifting techniques; keep back straight, lift with legs, keep load close to body, and never reach with a load. 2c. Avoid carrying too much equipment at one time and team-lift equipment that is more than 50 lb. 2d. Wear cut resistant gloves when handling the tripod and keep fingers away from pinch points located near moving parts of the tripod. Don't carry tripod by the pointed ends. 2e. When practical, set the height of the autolevel optic as to minimize bending at the waist.	

<sup>1</sup> Each Job or Operation consists of a set of tasks / steps. Be sure to list all the steps needed to perform job.

<sup>2</sup> A hazard is a potential danger. Break hazards into six types: Contact - victim is struck by or strikes an object; Caught - victim is caught on, caught in or caught between objects; Fall - victim falls to ground or lower level (includes slips and trips); Exertion - excessive strain or stress / ergonomics / lifting techniques; Exposure - inhalation/skin hazards; Energy Source - electricity, pressure, compression/tension.

<sup>3</sup> Using the first two columns as a guide, decide what actions or procedures are necessary to eliminate or minimize the risk. List the recommended safe operating procedures. Say exactly what needs to be done - such as "use two persons to lift". Avoid general statements such as, "be careful".

Assess <sup>1</sup> JOB STEPS	Analyze <sup>2</sup> POTENTIAL HAZARDS	Act <sup>3</sup> CRITICAL ACTIONS
3. Open / close manhole cover to well that is being surveyed (if necessary).	<p><b>3a. OVEREXERTION:</b> Muscle strain</p> <p><b>3b. CAUGHT:</b> Pinch points associated with removing / replacing manholes and working with hand tools</p> <p><b>3c. EXPOSURE:</b> To potentially hazardous vapors  To biological hazards</p> <p><b>3d. CONTACT:</b> With traffic</p>	<p>3a. See 1c. Bend knees when reaching to open well. Use manhole lifting hook or pry bar to avoid bending.</p> <p>3b. Wear leather gloves or cut resistant gloves when working with well cover and hand tools.</p> <p>3b. Use proper tools (ratchet and crowbar or pry bar for well cover) and inspect before use.</p> <p>3b. Do not put fingers under well cover.</p> <p>3c. No open flames/heat sources.</p> <p>3c. To minimize exposure to vapors, allow well to vent after opening it and before survey activities begin.</p> <p>3c. Work on the upwind side of manhole/well.</p> <p>3.c Use caution while opening lids to inspect work area for bees and insects inside of covers.</p> <p>3c. Use insect/tick repellent as necessary.</p> <p>3d. See 2b.</p>
4. Perform survey.	<p><b>4a. FALL:</b> Slip/trip hazards</p> <p><b>4b. CONTACT:</b> Traffic (surveying locations could be potentially located in parking areas and sidewalks)</p> <p><b>4c. ENERGY SOURCES:</b> Electrical shock from survey rod striking overhead electric lines or lights</p>	<p>4a. See 2a.</p> <p>4b. See 2b.</p> <p>4b. Personnel using the scope will be devoting most of their attention to the surveying activity and shall be aware of vehicular and pedestrian traffic. Personnel holding the measuring stick should be extra vigilant of survey personnel and communicate any potential hazards to the instrument person via handheld radio or similar means. Ensure reflective safety vest is worn.</p> <p>4c. Prior to raising and extending the survey rod, personnel should thoroughly inspect the area above the measuring point. If overhead electrical lines are encountered within 20 feet of the measuring point; stop work and consult with the office health and safety officer.</p>
5. Break down work area.	<p><b>5a. CONTACT:</b> Traffic (surveying locations can potentially be in parking areas and sidewalks)</p> <p><b>5b. EXERTION:</b> Hazard due to carrying, lifting, and bending while transporting equipment</p> <p><b>5c. CONTACT:</b> Personal injury or equipment damage by striking surroundings with an extended rod or unsecured tripod leg</p>	<p>5a. See 2b.</p> <p>5b. See 2c.</p> <p>5c. Ensure rod is entirely collapsed prior to mobilization / demobilization between survey points.</p> <p>5c. Ensure tripod legs are fully collapsed and secured with strap prior to mobilization / demobilization between set-ups.</p>

<sup>1</sup> Each Job or Operation consists of a set of tasks / steps. Be sure to list all the steps needed to perform job.

<sup>2</sup> A hazard is a potential danger. Break hazards into six types: Contact - victim is struck by or strikes an object; Caught - victim is caught on, caught in or caught between objects; Fall - victim falls to ground or lower level (includes slips and trips); Exertion - excessive strain or stress / ergonomics / lifting techniques; Exposure - inhalation/skin hazards; Energy Source – electricity, pressure, compression/tension.

<sup>3</sup> Using the first two columns as a guide, decide what actions or procedures are necessary to eliminate or minimize the risk. List the recommended safe operating procedures. Say exactly what needs to be done - such as "use two persons to lift". Avoid general statements such as, "be careful".



<b>JOB SAFETY ANALYSIS</b>		<b>Ctrl. No. GEN-011</b>	DATE: 8/6/2018	<input type="checkbox"/> NEW <input checked="" type="checkbox"/> REVISED	PAGE 1 of 2
JSA TYPE CATEGORY <b>Generic</b>	WORK TYPE <b>Construction - Excavation</b>	WORK ACTIVITY (Description) <b>Excavation / Trenching</b>			
<b>DEVELOPMENT TEAM</b>	<b>POSITION / TITLE</b>	<b>REVIEWED BY:</b>	<b>POSITION / TITLE</b>		
David Kaiser	Senior Engineer	Brian Hobbs	Corporate Health & Safety Manager		
Ian Holst	Senior Engineer				
<b>REQUIRED AND / OR RECOMMENDED PERSONAL PROTECTIVE EQUIPMENT</b>					
<input type="checkbox"/> LIFE VEST <input checked="" type="checkbox"/> HARD HAT <input checked="" type="checkbox"/> LONG SLEEVED SHIRT <input type="checkbox"/> LIFELINE / BODY HARNESS <input checked="" type="checkbox"/> SAFETY GLASSES	<input type="checkbox"/> GOGGLES <input type="checkbox"/> FACE SHIELD <input checked="" type="checkbox"/> HEARING PROTECTION <input checked="" type="checkbox"/> SAFETY SHOES: <u>Steel-toe boots</u>	<input type="checkbox"/> AIR PURIFYING RESPIRATOR <input type="checkbox"/> SUPPLIED RESPIRATOR <input checked="" type="checkbox"/> PPE CLOTHING: <u>Fluorescent reflective vest or high visibility long sleeved clothing</u>	<input checked="" type="checkbox"/> GLOVES: <u>Leather or cut resistant</u> <input type="checkbox"/> OTHER		
<b>REQUIRED AND / OR RECOMMENDED EQUIPMENT</b>					
Jackhammer, Excavator, Backhoe, Hand Tools, Photoionization Detector, barrels, 42" traffic cones, snow fencing, telescoping poles, temporary chain link fence, ladders, shovels, digging bars, power tools (cut-off saw), Two-way radios, Sheeting, Trench box, Retractable lanyard, Harness					
<b>COMMITMENT TO SAFETY</b> - All personnel onsite will actively participate in hazard recognition and mitigation throughout the day by verbalizing SPSAs					
<b>EXCLUSION ZONE (EZ): A 10-foot exclusion zone will be maintained around equipment in motion and outside the swing/tip radius.</b>					
<b>Assess 1JOB STEPS</b>	<b>Analyze 2POTENTIAL HAZARDS</b>	<b>Act 3CRITICAL ACTIONS</b>			
1. Pre-Clearance Protocol.	<b>1a. CONTACT:</b> Damage to underground utility.  <b>1b. ENERGY SOURCE/CONTACT:</b> Property damage; Pressurized water mains may cause lacerations or broken bones. Pressurized gas mains may explode causing serious injury, or death.  Underground electric may cause severe burns, shock, or death.  <b>1c. FALL:</b> Slip, Trip or Fall may cause muscle strains or tears, abrasions, lacerations, or broken bones.	1a. Confirm that (if applicable) "Call Before You Dig" and local utility companies were contacted prior to trenching in order to confirm utility mark outs. Must have a case # before digging.  1b. Pre-clearing of the trenching location must be conducted to a minimum of 5 vertical feet below the ground surface (10 feet minimum for Critical Zone) using hand tools (shovel and non-metallic dig bar) prior to trenching. Supervisor should be contacted to discuss appropriate pre-clearing depth. Complete subsurface clearance checklist.  1c. Be aware of the conditions when walking or loading equipment and working. Walk within established pathway avoiding uneven surfaces. Remove potential slip/trip/fall hazards.			
2. Set up work zone.	<b>2a. CONTACT/CAUGHT:</b> Cuts/lacerations from equipment. Broken bones from contact by vehicle.  <b>2b. FALL:</b> Slip, Trip or Fall may cause muscle strains or tears, abrasions, lacerations, or broken bones.	2a. Isolate work area from hazards with cones, barricades, and snow fencing, telescoping poles or temporary chain link fence. Utilize a flag person when necessary (i.e., third party traffic in area). Install traffic signs in roadways and for detours. Spotters will maintain and enforce exclusion zone.  2b. See 1c.			

<sup>1</sup> Each Job or Operation consists of a set of tasks / steps. Be sure to list all the steps needed to perform job.

<sup>2</sup> A hazard is a potential danger. Break hazards into six types: Contact - victim is struck by or strikes an object; Caught - victim is caught on, caught in or caught between objects; Fall - victim falls to ground or lower level (includes slips and trips); Exertion - excessive strain or stress / ergonomics / lifting techniques; Exposure - inhalation/skin hazards, energy source; Energy Source - electricity, pressure, compression/tension.

<sup>3</sup> Using the first two columns as a guide, decide what actions or procedures are necessary to eliminate or minimize the risk. List the recommended safe operating procedures. Say exactly what needs to be done - such as "use two persons to lift". Avoid general statements such as, "be careful".

Assess <sup>1</sup> JOB STEPS	Analyze <sup>2</sup> POTENTIAL HAZARDS	Act <sup>3</sup> CRITICAL ACTIONS
3. Trenching Activity.	<p><b>3a. CONTACT:</b> Serious injury including broken bones, muscle strains or tears, and possibly death due to contact with machine.</p> <p><b>3b. FALL:</b> Slip, Trip or Fall may cause muscle strains or tears, abrasions, lacerations, or broken bones</p> <p><b>3c. EXPOSURE:</b> Noise, Dust, Concrete- Asphalt, petroleum hydrocarbon vapors may cause damage to ears and lungs</p>	<p>3a. Spotter(s) required for all heavy equipment operation. No worker shall be allowed inside the exclusion zone or along the trench/excavation area while any equipment is in operation. A minimum exclusion zone greater than the length of the equipment boom must be established. Workers only allowed in exclusion zone if the operator is in "Hands Off "mode. Operator will not operate equipment until worker is out of exclusion zone. Spotters and operators will have radios for communication, when either loses sight of one another, and/or in case of emergency.</p> <p>3b. Any trench/excavation deeper than 3' must have a ladder within 25' of any worker in the excavation. At least 3'(rungs) of the ladder shall be above the top of the excavation. All spoil piles shall be maintained 2' minimum from edge of excavation.</p> <p>3b. Any trench/excavation deeper than 6' must have fall protection, retractable lanyard for ladder use, and 42" high guardrails along the edge of the trench/excavation.</p> <p>3c. Air monitoring using a calibrated photoionization detector (PID) will be used to monitor the breathing zone of the work area. If a reading of &gt;5ppm is recorded, the oversight personnel must temporarily cease work and instruct all Site personnel to step away from the area of elevated readings.</p>
4. Setting Trench protections if necessary.	<p><b>4a. CAUGHT:</b> Injury due to contact with failed trench, may include muscle strains or tears, abrasions or lacerations, broken bones and possibly death.</p> <p><b>4b. CONTACT/CAUGHT:</b> Injury due to rigging activities and entering exclusion zone during lifting and/or transport of shoring/trench box/material may include muscle strains or tears, abrasions or lacerations, broken bones and possibly death.</p> <p><b>4c. FALL:</b> Possible injury due to fall into excavation may include muscle strains or tears, abrasions or lacerations, or broken bones.</p>	<p>4a. To prevent cave-ins and avoid caught by/between, excavations over 4' in depth, unless working in stable rock, shall have engineer approved shoring, sheeting or trench box. Top of protection shall be at least 2' above top of excavation.</p> <p>4b. Use only inspected rigging with 2, 3 or 4 lift points; wear cut-resistant gloves. Rigging to be hooked up to factory installed hook up points on equipment. Control load with non-conductive tag lines with workers out of exclusion zone. Don't stand underneath suspended load; wear steel toed boots and hard hat.</p> <p>4c. Shoring to be set and sides will be backfilled to avoid fall hazards before workers are allowed to enter area. Operator will be in "HANDS OFF" mode before workers enter work area to unhook rigging. An inspected ladder extending 3' above top of the shoring will be used to enter and exit the shoring. Workers will use three points of contact when using the ladder.</p>
5. Secure/Leave Site. If backfilling, see excavation backfilling and compaction JSA for potential hazards and critical actions.	<p><b>5a. FALL:</b> Potential Slip, Trip or Fall - may cause muscle strains or tears, abrasions or lacerations, or broken bones.</p>	<p>5a. See 1c.</p> <p>5a. All open excavations must be backfilled or secured prior to departure with steel plates, orange construction fence or temporary chain link fencing.</p>

<sup>1</sup> Each Job or Operation consists of a set of tasks / steps. Be sure to list all the steps needed to perform job.

<sup>2</sup> A hazard is a potential danger. Break hazards into six types: Contact - victim is struck by or strikes an object;

Caught - victim is caught on, caught in or caught between objects; Fall - victim falls to ground or lower level (includes slips and trips); Exertion - excessive strain or stress / ergonomics / lifting techniques; Exposure - inhalation/skin hazards; Energy source – electricity, pressure, compression/tension.

<sup>3</sup> Using the first two columns as a guide, decide what actions or procedures are necessary to eliminate or minimize the risk. List the recommended safe operating procedures. Say exactly what needs to be done - such as "use two persons to lift". Avoid general statements such as, "be careful".

JOB SAFETY ANALYSIS		Ctrl. No. GEN-012	DATE 8/6/2018	<input type="checkbox"/> NEW <input checked="" type="checkbox"/> REVISED	PAGE 1 of 2
JSA TYPE CATEGORY <b>Generic</b>	WORK TYPE: <b>Construction - General</b>	WORK ACTIVITY (Description): <b>Installation or Repair of Chain Link Fence</b>			
<b>DEVELOPMENT TEAM</b>	<b>POSITION / TITLE</b>	<b>REVIEWED BY:</b>		<b>POSITION / TITLE</b>	
Ray Greenidge	OHSM	Brian Hobbs		Corporate Health & Safety Manager	
<b>REQUIRED AND / OR RECOMMENDED PERSONAL PROTECTIVE EQUIPMENT</b>					
<input type="checkbox"/> LIFE VEST <input checked="" type="checkbox"/> HARD HAT <input type="checkbox"/> LIFELINE / BODY HARNESS <input checked="" type="checkbox"/> SAFETY GLASSES	<input type="checkbox"/> GOGGLES <input type="checkbox"/> FACE SHIELD <input checked="" type="checkbox"/> HEARING PROTECTION <input checked="" type="checkbox"/> SAFETY SHOES: <u>Steel or Composite toed boots</u>	<input type="checkbox"/> AIR PURIFYING RESPIRATOR <input type="checkbox"/> SUPPLIED RESPIRATOR <input checked="" type="checkbox"/> PPE CLOTHING: <u>Fluorescent reflective vest or high visibility clothing</u>	<input checked="" type="checkbox"/> GLOVES: <u>Cut-resistant</u> <input type="checkbox"/> OTHER		
<b>REQUIRED AND / OR RECOMMENDED EQUIPMENT</b>					
Required Equipment: Fence materials, Hand tools, Power Tools, GFCI					
<b>COMMITMENT TO SAFETY-</b> All personnel onsite will actively participate in hazard recognition and mitigation throughout the day by verbalizing SPSAs.					
<b>Assess 1JOB STEPS</b>	<b>Analyze 2POTENTIAL HAZARDS</b>	<b>Act 3CRITICAL ACTIONS</b>			
1. Secure work zone	1a. <b>FALL:</b> Slip, trip, or fall hazards associated with site conditions.  1b. <b>CONTACT:</b> Vehicular and pedestrian traffic.	1a. Maintain good housekeeping and keep work area free of potential Slip, Trip and Fall hazards. 1b. Utilize Traffic Control devices to secure work zone (42" traffic cones with flags, and caution tape).  1b. Use work truck or rigid barriers to barricade the side of work area in the line-of-fire of vehicular traffic.			
2. Development of anchor locations for Post-Holes for fences using either a Hammer drill or Post-Hole digger.	2a. <b>CONTACT:</b> Potential cut/abrasion hazards and splinters. Operation of hammer drill can result in ejected debris and eye hazard.  2b. <b>ERGONOMICS:</b> Back strain while maneuvering Post-Hole digger or Shovel.  2c. <b>EXPOSURE:</b> Operation of hammer drill can generate greater than 85 dBAs  2d. <b>ENERGY SOURCE:</b> Electric hazards from operation of power tools.  2e. <b>ERGONOMICS:</b> Vibration injury.  2f. <b>EXPOSURE:</b> Exposure to generator noise/fumes.  2g. <b>FALL:</b> Trip hazards from equipment being left in work zone.	2a. De-energize power tools by removing battery packs or unplugging electrical supply prior to switching out components (i.e., Sawsall blades or drill bits). 2a. Unplug from electrical power or remove battery pack from tools before handing them off to another person. 2a. Wear Cut resistant gloves and safety glasses.  2b. Utilize proper lifting techniques when using digging tools. Keep back straight, bend at the knees, keep load close to body, turn with legs, and do not twist back. 2b. Inspect post-hole digger prior to use. Ensure there are no splinters on handle. Ensure that the shovel section bolts are in good working condition. 2b. Wear leather or cut-resistant gloves.  2c. Wear hearing protection. Personnel not involved in the task must stand at least 10-foot away from the operating hammer drill.  2d. Use heavy-duty, outdoor cords with ground, rated for the electrical load required. Inspect extension cords, verify good condition; no exposed wires, cuts, damage, worn insulation, or damaged plugs. 2d. If the use of a generator is required, do not refuel generator while it is running. 2d. Use GFCI.  2e. Wear vibration resistant gloves.  2f. See 2c.  2f. Position generator such that exhaust is pointed away from workers or downwind of work area. Wear hearing protection if generator cannot be positioned out of the work area and if noise levels exceed 85 dBAs.  2g. Maintain good housekeeping and keep work area free of Slip, Trip and Fall hazards. Stage tools in designated areas at lowest potential energy. 2g. When possible route extension cords and hoses overhead or outside of walk path.			

<sup>1</sup> Each Job or Operation consists of a set of tasks / steps. Be sure to list all the steps needed to perform job.

<sup>2</sup> A hazard is a potential danger. Break hazards into six types: Contact - victim is struck by or strikes an object;

Caught - victim is caught on, caught in or caught between objects; Fall - victim falls to ground or lower level (includes slips and trips); Exertion - excessive strain or stress / ergonomics / lifting techniques; Exposure - inhalation/skin hazards; Energy Source - electricity, pressure, compression/tension.

<sup>3</sup> Using the first two columns as a guide, decide what actions or procedures are necessary to eliminate or minimize the risk. List the recommended safe operating procedures. Say exactly what needs to be done - such as "use two persons to lift." Avoid general statements such as, "be careful."

Assess <sup>1</sup> JOB STEPS	Analyze <sup>2</sup> POTENTIAL HAZARDS	Act <sup>3</sup> CRITICAL ACTIONS
3. Manual lifting of fence materials	<p><b>3a. EXERTION/ERGONOMICS:</b> Back strain and personal injury from lifting heavy loads.</p> <p><b>3b. CONTACT:</b> Potential cut/abrasion hazards.</p>	<p>3a. 50 lbs is the maximum allowable weight per manual lift. Use a mechanical lifting device or the buddy system if the weight is greater than 50 lbs.</p> <p>3a. Keep back straight, bend at the knees, and keep load close to body when lifting.</p> <p>3a. Use buddy system when lifting awkward materials.</p> <p>3b. Ensure long sleeves are covering arms, wear cut-resistant gloves. Avoid grabbing sharp edges.</p>
4. Installation of chain link fence or fabric.	<p><b>4a. OVEREXERTION:</b> Back strain and personal injury from lifting heavy loads</p> <p><b>4b. CONTACT:</b> Potential cut/abrasion hazards on fencing.</p>	<p>4a. See 3a.</p> <p>4b. Avoid sharp edges on fencing; ensure long sleeved shirts are fully covering arms, wear cut-resistant gloves.</p> <p>4b. Use retractable knife for cutting privacy fabric.</p>
5. Housekeeping.	<p><b>5a. FALL:</b> Slip, trip, fall hazards from items left in the work zone.</p>	<p>5a. Clean up loose items including fabric cuttings, tools, etc.</p> <p>5a. Remove Slip, Trip and Fall hazards from the work area.</p> <p>5a. Inspect work area to verify it is left in a safe condition.</p>

<sup>1</sup> Each Job or Operation consists of a set of tasks / steps. Be sure to list all the steps needed to perform job.

<sup>2</sup> A hazard is a potential danger. Break hazards into six types: Contact - victim is struck by or strikes an object;

Caught - victim is caught on, caught in or caught between objects; Fall - victim falls to ground or lower level (includes slips and trips); Exertion - excessive strain or stress / ergonomics / lifting techniques; Exposure - inhalation/skin hazards; Energy Source - electricity, pressure, compression/tension.

<sup>3</sup> Using the first two columns as a guide, decide what actions or procedures are necessary to eliminate or minimize the risk. List the recommended safe operating procedures. Say exactly what needs to be done - such as "use two persons to lift". Avoid general statements such as, "be careful".

<b>JOB SAFETY ANALYSIS</b> Ctrl. No. GEN-013		DATE 8/6/2018	<input type="checkbox"/> NEW <input checked="" type="checkbox"/> REVISED	PAGE 1 of 2
JSA TYPE CATEGORY <b>Generic</b>	WORK TYPE: <b>Gauging and Sampling</b>	WORK ACTIVITY (Description): <b>Gauging and Sampling</b>		
<b>DEVELOPMENT TEAM</b>	<b>POSITION / TITLE</b>	<b>REVIEWED BY:</b>	<b>POSITION / TITLE</b>	
Brandon Tufano	Staff Geologist	Brian Hobbs	Corporate Health & Safety Manager	
<b>REQUIRED AND / OR RECOMMENDED PERSONAL PROTECTIVE EQUIPMENT</b>				
<input checked="" type="checkbox"/> LIFE VEST <input checked="" type="checkbox"/> HARD HAT <input type="checkbox"/> LIFELINE / BODY HARNESS <input checked="" type="checkbox"/> SAFETY GLASSES	<input type="checkbox"/> GOGGLES <input type="checkbox"/> FACE SHIELD <input type="checkbox"/> HEARING PROTECTION <input checked="" type="checkbox"/> SAFETY SHOES: <u>Composite-toe or steel toe boots</u>	<input type="checkbox"/> AIR PURIFYING RESPIRATOR <input type="checkbox"/> SUPPLIED RESPIRATOR <input checked="" type="checkbox"/> PPE CLOTHING: <u>Fluorescent reflective vest or high visibility clothing</u>	<input checked="" type="checkbox"/> GLOVES: <u>Leather, Nitrile and cut resistant</u> <input checked="" type="checkbox"/> OTHER: <u>Knee pads, Insect Repellant, sunscreen (as needed)</u>	
<b>REQUIRED AND / OR RECOMMENDED EQUIPMENT</b>				
42-inch Safety Cones, Caution Tape, Interface Probe and/or Water Level Meter, 20-lb., Type ABC Fire Extinguisher, Buckets. Tools as needed: Socket Wrench, Screw Driver, Crow Bar, Mallet, and Wire Brush.				
<b>COMMITMENT TO SAFETY-</b> All personnel onsite will actively participate in hazard recognition and mitigation throughout the day by verbalizing SPSAs				
<b>Assess 1JOB STEPS</b>	<b>Analyze 2POTENTIAL HAZARDS</b>	<b>Act 3CRITICAL ACTIONS</b>		
1. Mobilization to monitoring well(s).	1a. <b>FALL:</b> Personal injury from slip/trip/fall due to uneven terrain and/or obstructions.  1b. <b>CONTACT:</b> With traffic/third parties.  1c. <b>EXERTION:</b> Muscle strain from lifting equipment  1d. <b>EXPOSURE:</b> To biological hazards.	1a. Inspect pathway and plan for most suitable designated pathway prior to mobilization. 1a. Use established pathways, walk and/or drive on stable, secure ground and avoid steep hills or uneven terrain. 1a. If working near open water with an unguarded edge, wear life vest.  1b. Identify potential traffic sources and delineate work area with 42-inch traffic safety cones. Position vehicle to protect against oncoming traffic. Use caution tape to provide a more visible delineation of the work area if necessary. 1b. Wear appropriate PPE including high visibility clothing or reflective vest. 1b. Face traffic, maintain eye contact with oncoming vehicles, and establish a safe exit route.  1c. Use proper lifting techniques when handling/moving equipment; bend knees and keep back straight. 4c. Use mechanical assistance or team lifting techniques when equipment is 50 lbs. or heavier. 4c. Make multiple trips to carry equipment.  1d. Inspect work area for bees and insects. 1d. Use insect/tick repellent as necessary.		
2. Open/close well.	2a. <b>EXERTION:</b> Muscle strain.  2b. <b>CAUGHT:</b> Pinch/crush points associated with removing/replacing manholes and working with hand tools.  2c. <b>CAUGHT:</b> Pinch points associated with placing J-plug back onto PVC pipe.  2d. <b>EXPOSURE:</b> To potential hazardous vapors.	2a. Use proper lifting techniques; keep back straight, lift with legs and bend knees when reaching to open/close well.  2b. Wear leather gloves or cut resistant gloves when working with well cover and hand tools. 2b. Use proper tools (ratchet and pry bar for well cover) and inspect before use. 2b. Do not put fingers under well cover.  2c. See 2b. 2c. Keep fingers out of line-of-fire when securing cap.  2d. No open flames/heat sources. 2d. To minimize exposure to vapors, allow well to vent after opening it and before sampling activities begin. 2d. Stand up-wind, if possible, to avoid inhaling vapors.		
3. Gauge well.	3a. <b>CONTACT:</b> With contamination (e.g. contaminated groundwater).  3b. <b>CONTACT:</b> With traffic.	3a. Wear chemical-resistant disposable gloves (over cut-resistant gloves) and safety glasses when gauging well. 3a. Insert and remove probe slowly to avoid splashing. 3a. Use an absorbent pad to clean probe.  3b. See 1b.		

<sup>1</sup> Each Job or Operation consists of a set of tasks / steps. Be sure to list all the steps needed to perform job.

<sup>2</sup> A hazard is a potential danger. Break hazards into six types: Contact - victim is struck by or strikes an object;

Caught - victim is caught on, caught in or caught between objects; Fall - victim falls to ground or lower level (includes slips and trips); Exertion - excessive strain or stress / ergonomics / lifting techniques; Exposure - inhalation/skin hazards; Energy Source - electricity, pressure, compression/tension.

<sup>3</sup> Using the first two columns as a guide, decide what actions or procedures are necessary to eliminate or minimize the risk. List the recommended safe operating procedures. Say exactly what needs to be done - such as "use two persons to lift". Avoid general statements such as, "be careful".

Assess <sup>1</sup> JOB STEPS	Analyze <sup>2</sup> POTENTIAL HAZARDS	Act <sup>3</sup> CRITICAL ACTIONS
4. Purge and sample well	<p><b>4a. EXPOSURE/CONTACT:</b> To contamination (e.g., SPH, contaminated groundwater, vapors) and/or sample preservatives.</p> <p><b>4b. CONTACT:</b> Personal injury from cuts, abrasions, or punctures by glassware or sharp objects.</p> <p><b>4c. EXERTION:</b> Muscle strain while carrying equipment.</p> <p><b>4d. CONTACT:</b> With traffic.</p> <p><b>4e. CONTACT:</b> Pinch points with groundwater pump components (i.e., wheel, line, clamps).</p> <p><b>4f. EXERTION:</b> Muscle strain from repetitive motion of bailing and sampling a well.</p>	<p>4a. Open and fill sample jars slowly to avoid splashing and contact with preservatives.</p> <p>4a. Wear cut-resistant gloves and chemical-resistant disposable gloves when sampling.</p> <p>4a. Fill sample containers over purge container to avoid spilling water onto the ground.</p> <p>4a. Use an absorbent pad to clean spills.</p> <p>4a. When using a bailer to purge a well, pull the bailer slowly from the well to avoid splash hazards.</p> <p>4a. When sampling or purging the water using a bailer, pour out water slowly to reduce the potential for splash hazards with groundwater.</p> <p>4a. When using a tubing valve always remove the valve slowly after sample collection to release any pressure and avoid pressurized splash hazards.</p> <p>4a. When collecting a groundwater sample always point sampling apparatus (tubing, bailer, etc.) away from face and body.</p> <p>4b. To avoid spills or breakage, place sample ware on even surface.</p> <p>4b. Do not over tighten caps on glass sample ware.</p> <p>4b. Wear chemical-resistant nitrile disposable gloves over cut-resistant (i.e., Kevlar) gloves when sampling and handling glassware (i.e., VOA vials) or when using cutting tools.</p> <p>4c. Use proper lifting techniques when handling/moving equipment, bend knees and keep back straight.</p> <p>4c. Use mechanical assistance or team lifting techniques when equipment is 50 lbs. or heavier.</p> <p>4c. Make multiple trips to carry equipment.</p> <p>4d. See 1b.</p> <p>4e. Wear leather gloves when working with groundwater pumps.</p> <p>4e. Never place hands on or near pinch points such as the wheel, clamps or other moving parts during pump operations.</p> <p>4e. Use the correct mechanisms, such as a pump reel, to lower pump into well.</p> <p>4e. Never attempt to manually stop any moving part of equipment including hose reels and/or tubing.</p> <p>4f. See 4c.</p> <p>4f. Include a stretch break when repetitive motions are part of the task.</p>
5. Management of purge water.	<p><b>5a. EXPOSURE/CONTACT:</b> To contamination (e.g., SPH, contaminated groundwater, vapors).</p> <p><b>5b. EXERTION:</b> Muscle strain from lifting/carrying and moving containers.</p>	<p>5a. Do not overfill container and pour liquids slowly so that they do not splash.</p> <p>5a. Properly dispose of used materials/PPE in appropriate container in designated storage area.</p> <p>5b. Use proper lifting techniques when lifting / carrying or moving container(s) (see 4c.).</p> <p>5b. Do not overfill container(s).</p>
6. Decontaminate equipment.	<p><b>6a. EXPOSURE/CONTACT:</b> To contamination (e.g., SPH, contaminated groundwater, vapors).</p> <p><b>6b. CAUGHT:</b> Pinch points associated with handling hand tools</p>	<p>6a. Work on the upwind side, where possible, of decon area.</p> <p>6a. Wear chemical-resistant disposable gloves and safety glasses.</p> <p>6a. Use an absorbent pad to clean spills.</p> <p>6b. See 2b.</p> <p>6b. Inspect hand tools for sharp edges before decontaminating.</p>

<sup>1</sup> Each Job or Operation consists of a set of tasks / steps. Be sure to list all the steps needed to perform job.

<sup>2</sup> A hazard is a potential danger. Break hazards into six types: Contact - victim is struck by or strikes an object;

Caught - victim is caught on, caught in or caught between objects; Fall - victim falls to ground or lower level (includes slips and trips); Exertion - excessive strain or stress / ergonomics / lifting techniques; Exposure - inhalation/skin hazards; Energy Source - electricity, pressure, compression/tension.

<sup>3</sup> Using the first two columns as a guide, decide what actions or procedures are necessary to eliminate or minimize the risk. List the recommended safe operating procedures. Say exactly what needs to be done - such as "use two persons to lift". Avoid general statements such as, "be careful".

<b>JOB SAFETY ANALYSIS</b>		Ctrl. No. <b>GEN-014</b>	DATE: 8/6/2018	<input type="checkbox"/> NEW <input checked="" type="checkbox"/> REVISED	PAGE 1 of 2
JSA TYPE CATEGORY: <b>Generic</b>		WORK TYPE: <b>Drilling</b>	WORK ACTIVITY (Description): <b>Hollow Stem Auger Soil Borings / Well Installation</b>		
<b>DEVELOPMENT TEAM</b>		<b>POSITION / TITLE</b>	<b>REVIEWED BY:</b>	<b>POSITION / TITLE</b>	
Douglas Ferraiolo		Staff Geologist	Brian Hobbs	Corporate Health & Safety Manager	
<b>REQUIRED AND / OR RECOMMENDED PERSONAL PROTECTIVE EQUIPMENT</b>					
<input type="checkbox"/> LIFE VEST <input checked="" type="checkbox"/> HARD HAT <input type="checkbox"/> LIFELINE / BODY HARNESS <input checked="" type="checkbox"/> SAFETY GLASSES	<input checked="" type="checkbox"/> GOGGLES: <u>Spoggles required if winds exceed 15 mph.</u> <input type="checkbox"/> FACE SHIELD <input checked="" type="checkbox"/> HEARING PROTECTION: <u>(as needed).</u> <input checked="" type="checkbox"/> SAFETY SHOES: <u>Steel or Composite Toe.</u>	<input type="checkbox"/> AIR PURIFYING RESPIRATOR <input type="checkbox"/> SUPPLIED RESPIRATOR <input checked="" type="checkbox"/> PPE CLOTHING: <u>Fluorescent long-sleeve shirt or long-sleeve shirt and reflective safety vest.</u>	<input checked="" type="checkbox"/> GLOVES: <u>Leather, Cut-Resistant, and Nitrile.</u> <input checked="" type="checkbox"/> OTHER: <u>Insect Repellent, Sunscreen (as needed).</u>		
<b>REQUIRED AND / OR RECOMMENDED EQUIPMENT</b>					
Truck-Mounted Drilling Rig or Track Rig, Saw, Hand Tools, Photoionization Detector, Multi-Gas Meter (or equivalent), Interface Probe, 20 lb. Type ABC Fire Extinguisher, 42" Cones & Flags, "Work Area" Signs.					
<b>COMMITMENT TO SAFETY-</b> All personnel onsite will actively participate in hazard recognition and mitigation throughout the day by verbalizing SPSAs					
<b>EXCLUSION ZONE (EZ) – All non-essential personnel shall maintain a 10 foot exclusion zone while drill rig is engaged.</b>					
<b>"SHOW ME YOUR HANDS"</b>					
<b>Driller and helper should show that hands are clear from controls and moving parts</b>					
<b>Assess 1JOB STEPS</b>	<b>Analyze 2POTENTIAL HAZARDS</b>	<b>Act 3CRITICAL ACTIONS</b>			
1. Mobilization / demobilization and establish a work area.	1a. <b>See Mobilization/ Demobilization JSA GEN-015.</b>	1a. See Mobilization / Demobilization JSA GEN-015.			
2. Raising tower / derrick of drilling rig.	2a. <b>CONTACT:</b> Overhead hazards.  2b. <b>CONTACT:</b> Amputation / crush points when raising the rig and instability of rig.	2a. Prior to raising the tower / derrick, the area above the drilling rig will be inspected for overhead hazards (wires, tree limbs, piping or other structures) that may be contacted by the rig's tower or drilling rods. 2a. The tower / derrick must not be raised beneath overhead power lines unless approved by the Roux PM. 2a. Maintain a minimum of 10' from all overhead structures. 2a. Do not move the rig while the tower / derrick is raised. 2b. Inspect the equipment prior to use and avoid any potential amputation points. 2b. Lower outriggers to ensure stability prior to raising rig tower derrick. Keep feet and body out of the line of fire when lowering out-riggers. 2b. Inspect the set-up location for uneven terrain. Level or avoid area if needed. 2b. If the rig needs to be mounted, be sure to use three points of contact.			
3. Advancement of augers for soil boring installation.	3a. <b>CONTACT:</b> Equipment imbalance during advancement of drill equipment.  3b. <b>CONTACT:</b> Flying / spraying debris.  3c. <b>CAUGHT:</b> Limb/extremity amputation, abrasion, and crushing.	3a. Drillers will advance the borehole with caution to avoid causing the rig to become imbalanced and / or tip. 3a. The blocking and leveling devices used to secure the rig will be inspected by drillers and Roux personnel regularly to see if shifting has occurred. 3a. Drillers will maintain the "Purple Zone" policy surrounding augers to ensure no personnel come into contact with augers while in use. Workers will spray paint a 3' semi-circle surrounding the augers to visually show that no personnel should enter the "Purple Zone" while drilling activities are being conducted. 3a. In addition, personnel and equipment that are non-essential to the advancement of the borehole will be positioned away from the rig at a distance that is at least as far as the boom is high (minimum exclusion zone of 20 feet). 3b. Wear all required PPE (especially hand, eye, and ear protection). 3b. Maintain minimum 20' EZ distance when rig is in operation to avoid potential line of fire hazards from flying materials or debris. 3c. Inspect the equipment prior to use for potential pinch points. 3c. Test all emergency shutdown devices prior to drilling. 3c. Inspect drill head for worn surface or missing teeth; replace if damaged or blunt. 3c. Inspect augers, do not use if auger flight is damaged or bent.			

<sup>1</sup> Each Job or Operation consists of a set of tasks / steps. Be sure to list all the steps needed to perform job.

<sup>2</sup> A hazard is a potential danger. Break hazards into six types: Contact - victim is struck by or strikes an object; Caught - victim is caught on, caught in or caught between objects; Fall - victim falls to ground or lower level (includes slips and trips); Exertion - excessive strain or stress / ergonomics / lifting techniques; Exposure - inhalation/skin hazards; Energy Source - electricity, pressure, compression/tension.

<sup>3</sup> Using the first two columns as a guide, decide what actions or procedures are necessary to eliminate or minimize the risk. List the recommended safe operating procedures. Say exactly what needs to be done - such as "use two persons to lift." Avoid general statements such as, "be careful."

Assess 1JOB STEPS	Analyze 2POTENTIAL HAZARDS	Act 3CRITICAL ACTIONS
3. Advancement of augers for soil boring installation (Continued).	<p>3d. <b>FALL:</b> Slip/trip/fall hazards.</p> <p>3e. <b>EXPOSURE:</b> Inhalation of contamination / vapors.</p> <p>3f. <b>EXPOSURE:</b> Noise and dust.</p> <p>3g. <b>EXERTION:</b> Installing well casings and lifting augers.</p>	<p>3c. Ensure all jewelry is removed, loose clothing is secured, and PPE is secured close to the body.</p> <p>3c. All non-essential personnel should stay away from the immediate work area; position body out of the line-of-fire of equipment particularly when installing auger flights and steel override casings.</p> <p>3c. Drillers and helpers will understand and use the "Show Me Your Hands" Policy.</p> <p>3c. Spinning augers should have an exclusion zone of 20 feet when in operation.</p> <p>3d. Inspect walking path for uneven terrain, weather-related hazards (i.e., ice, puddles, snow, etc.), and obstructions prior to mobilizing equipment.</p> <p>3d. Do not climb over stored materials/equipment; walk around. Practice good housekeeping.</p> <p>3d. Use established pathways and walk on stable, secure ground.</p> <p>3d. Use three points of contact when mounting or dismounting the rig.</p> <p>3d. Remove soil cuttings to avoid a tripping hazard from developing near augers.</p> <p>3e. Air monitoring using a calibrated photoionization detector (PID) to periodically monitor the breathing zone of the work area.</p> <p>3e. The Action Level for breathing zone air is five parts per million (sustained) as detected by the PID.</p> <p>3e. If a reading of &gt;5ppm is recorded, the Roux field personnel must temporarily cease work, instruct all Site personnel to step away from the area of elevated readings and inform the Roux PM of the condition. The Roux PM will then recommend additional appropriate precautions in accordance with the site specific health and safety plan.</p> <p>3f. Wet borehole area with sprayer to minimize dust. Stand upwind and keep body positioned away from rig.</p> <p>3f. Wear hearing protection while drill rig is operating and / or the noise levels exceed 85 dBA.</p> <p>3g. Keep back straight and bend at the knees.</p> <p>3g. Utilize team lifting for objects over 50lbs.</p> <p>3g. Use mechanical lifting device for odd shaped objects.</p>
4. Installation of well materials.	<p>4a. <b>CONTACT:</b> Installing well materials while also pulling up augers.</p> <p>4b. <b>CAUGHT:</b> Possible pinch or crush hazard assembling PVC and sending down the borehole.</p> <p>4c. <b>FALL:</b> Slip/trip/fall hazards with hand tools and materials.</p> <p>4d. <b>EXPOSURE:</b> Potential contamination, harmful vapors, dust, and / or noise.</p> <p>4e. <b>EXERTION:</b> Lifting heavy bags of materials to backfill borehole.</p>	<p>4a. Potential contact with augers during installation of well materials.</p> <p>4a. Keep distance from augers and do not place any materials while augers are in motion.</p> <p>4b. Keep all body parts out of potential pinch points while placing PVC together and sending down borehole.</p> <p>4c. See 3d.</p> <p>4d. See 3e and 3f.</p> <p>4d. Stand upwind to avoid exposure to dust generated from packing materials.</p> <p>4e. Ergonomic hazard lifting bags of sand and bentonite while packing the well.</p>
5. Cleaning the auger flights	<p>5a. <b>CONTACT:</b> Cuts/scrapes or puncture wound from contacting auger.</p>	<p>5a. Follow "Show Me Your Hands" Procedure and make sure auger is out of gear before contacting auger with tool or hand.</p> <p>5a. Pull cleaning tool across your body with handle away from body; do not push toward the auger.</p> <p>5a. Do not clean more than ¼ turn around the auger at a time.</p> <p>5a. Wear cut resistant and leather gloves.</p> <p>5a. Always use two hands to operate cleaning tool.</p> <p>5a. Inspect tool before use and remove from service if handle or metal are cracked/fatigued.</p> <p>5a. Stand out of the line of fire.</p>
6. Decontaminate equipment.	<p>6a. <b>EXPOSURE / CONTACT:</b> To contamination (e.g., contaminated groundwater, vapors).</p> <p>6b. <b>EXPOSURE:</b> To chemicals in cleaning solution (including ammonia).</p>	<p>6a. Wear chemical-resistant disposable gloves and safety glasses.</p> <p>6a. Contain decontamination water so that it does not spill.</p> <p>6a. Use an absorbent pad to clean spills, if necessary.</p> <p>6b. See 3e. Wear all appropriate PPE and stand upwind of any exposed cleaning solutions.</p>

<sup>1</sup> Each Job or Operation consists of a set of tasks / steps. Be sure to list all the steps needed to perform job.

<sup>2</sup> A hazard is a potential danger. Break hazards into six types: Contact - victim is struck by or strikes an object; Caught - victim is caught on, caught in or caught between objects; Fall - victim falls to ground or lower level (includes slips and trips); Exertion - excessive strain or stress / ergonomics / lifting techniques; Exposure - inhalation/skin hazards; Energy Source - electricity, pressure, compression/tension.

<sup>3</sup> Using the first two columns as a guide, decide what actions or procedures are necessary to eliminate or minimize the risk. List the recommended safe operating procedures. Say exactly what needs to be done - such as "use two persons to lift." Avoid general statements such as, "be careful."



<b>JOB SAFETY ANALYSIS</b>		<b>Ctrl. No. GEN-015</b>	DATE: 8/6/2018	<input type="checkbox"/> NEW <input checked="" type="checkbox"/> REVISED	PAGE 1 of 2
JSA TYPE CATEGORY <b>GENERIC</b>		WORK TYPE <b>Site Recon</b>	WORK ACTIVITY (Description) <b>Mobilization/Demobilization</b>		
<b>DEVELOPMENT TEAM</b>		<b>POSITION / TITLE</b>	<b>REVIEWED BY:</b>	<b>POSITION / TITLE</b>	
Rebecca Lowy		Staff Assistant Geologist	Brian Hobbs	Corporate Health & Safety Manager	
Tally Sodre		OHSM			
<b>REQUIRED AND / OR RECOMMENDED PERSONAL PROTECTIVE EQUIPMENT</b>					
<input type="checkbox"/> LIFE VEST <input checked="" type="checkbox"/> HARD HAT <input type="checkbox"/> LIFELINE / BODY HARNESS <input checked="" type="checkbox"/> SAFETY GLASSES		<input type="checkbox"/> GOGGLES <input type="checkbox"/> FACE SHIELD <input checked="" type="checkbox"/> HEARING PROTECTION (as needed) <input checked="" type="checkbox"/> SAFETY SHOES: <u>Steel Toe or composite toe</u>	<input type="checkbox"/> AIR PURIFYING RESPIRATOR <input type="checkbox"/> SUPPLIED RESPIRATOR <input checked="" type="checkbox"/> PPE CLOTHING: <u>Fluorescent reflective vest</u> <u>of high-visibility clothing;</u> <u>long sleeve shirt; long pants</u>	<input checked="" type="checkbox"/> GLOVES: <u>Leather, nitrile, and cut resistant (as needed)</u> <input type="checkbox"/> OTHER	
<b>REQUIRED AND / OR RECOMMENDED EQUIPMENT</b>					
Required Equipment: Varies					
<b>COMMITMENT TO SAFETY-</b> All personnel onsite will actively participate in hazard recognition and mitigation throughout the day by verbalizing SPSAs					
<b>EXCLUSION ZONE (EZ): A 10-foot exclusion zone will be maintained around equipment in use..</b>					
<b>Assess 1JOB STEPS</b>	<b>Analyze 2POTENTIAL HAZARDS</b>	<b>Act 3CRITICAL ACTIONS</b>			
1. Mobilize/demobilize and establish work area	<b>1a. FALL:</b> Slip/trips/falls from obstructions, uneven terrain, weather conditions, heavy loads, and/or poor housekeeping.  <b>1b. CONTACT:</b> Personal injury and/or property damage caused by being struck by Site traffic or equipment used in Site activities.	1a. Use 3 points-of-contact/ensure secure footing when entering and exiting vehicle. 1a. Inspect walking path for uneven terrain, steep hills, obstructions, and/or weather-related hazards (i.e., ice, snow, and puddles) prior to mobilizing equipment. Use established pathways. Walk on stable/secure ground. 1a. Do not climb over stored materials/equipment; walk around. Practice good housekeeping; organize and store equipment neatly in one area at its lowest potential energy. 1a. Wear boots with adequate treads. 1a. Delineate unsafe areas with 42" cones, caution tape and/or flagging.  1b. Observe and maintain the posted speed limits. 1b. When first arriving onsite, park vehicles in designated parking space and/or out of the way locations. Use parking brake on all vehicles and tire chocks on work trucks and trailers. 1b. Check in with Site Manager/Supervisor to ensure coordination with other Site activities and to discuss any special hazards. Ensure that short-service employees (SSE) are identified. 1b. Identify potential traffic sources. 1b. Wear PPE including high visibility clothing or reflective vest. 1b. Use a spotter while moving work vehicles; plan ahead to avoid backing whenever possible. 1b. Maintain a minimum 10' exclusion zone when vehicles are in motion. When backing up truck rig with an attached trailer use a second spotter if there is tight clearance simultaneously on multiple sides of the equipment or if turning angles limit driver-to-spotter visibility. 1b. Delineate work area with 42" cones, flags, caution tape, and/or other barriers. 1b. Position "Work Area" signs at Site entrances, if possible, or at either side of work area.			

<sup>1</sup> Each Job or Operation consists of a set of tasks / steps. Be sure to list all the steps needed to perform job.

<sup>2</sup> A hazard is a potential danger. Break hazards into six types: Contact - victim is struck by or strikes an object; Caught - victim is caught on, caught in or caught between objects; Fall - victim falls to ground or lower level (includes slips and trips); Exertion - excessive strain or stress / ergonomics / lifting techniques; Exposure - inhalation/skin hazards; Energy Source - electricity, pressure, compression/tension.

<sup>3</sup> Using the first two columns as a guide, decide what actions or procedures are necessary to eliminate or minimize the risk. List the recommended safe operating procedures. Say exactly what needs to be done - such as "use two persons to lift." Avoid general statements such as, "be careful."

Assess <sup>1</sup> JOB STEPS	Analyze <sup>2</sup> POTENTIAL HAZARDS	Act <sup>3</sup> CRITICAL ACTIONS
	<p><b>1c. CAUGHT:</b> Personal injury from pinch points and being in line-of-fire of vehicle and/or equipment.</p> <p><b>1d. OVEREXERTION:</b> Muscle strains while lifting/carrying equipment.</p> <p><b>1e. EXPOSURE:</b> Personal injury from exposure to biological and environmental hazards.</p> <p><b>1f. EXPOSURE:</b> Weather related injuries.</p> <p><b>1g. EXPOSURE:</b> Personal injury from noise hazards.</p>	<p>1b. Position largest vehicle to protect against oncoming traffic.</p> <p>1b. Face traffic, maintain eye contact with oncoming vehicles, use a spotter, and establish a safe exit route.</p> <p>1b. Observe potential overhead and ground surface features that may interfere with moving equipment. Clear the path of physical hazards prior to initiating mobilization.</p> <p>1c. Make sure driver has engaged parking brake and placed wheel chocks in a position to prevent movement. Be sure that vehicle is parked in front/down gradient (positioned to best block oncoming traffic) of work area.</p> <p>1c. Wear leather gloves when handling any tools or equipment. Wear cut-resistant gloves (Kevlar or similar) when handling sharp objects/cutting tools/glass.</p> <p>1c. Keep body parts away from line-of-fire of equipment.</p> <p>1c. Always carry tools by the handles and/or designated carrier. Ensure sharp-edged tools are sheathed/secure.</p> <p>1c. Remove any loose jewelry. Avoid wearing loose clothing and/or ensure loose clothing is secure.</p> <p>1c. Secure all items on the equipment, tighten up any items or features that have potential to shift or break during mobilization.</p> <p>1d. Use body positioning and lifting techniques that avoid muscle strain; keep back straight, lift with legs, turn with whole body, keep load close to body, and never reach with a load.</p> <p>1d. Ensure that loads are balanced. Use assistance (mechanical or additional person) to carry equipment that is either unwieldy or over 50 lbs.</p> <p>1e. Inspect area to avoid contact with biological hazards (i.e. poisonous plants, stinging insects, ticks, etc.).</p> <p>1e. Wear long sleeved clothes treated with Permethrin, apply insect repellent containing DEET to exposed skin, and inspect clothes and skin for ticks during and after work.</p> <p>1e. Apply sunscreen (SPF 15+) if exposure to sun for 30 minutes or more is expected.</p> <p>1f. Watch for heat stress symptoms (muscle cramping, exhaustion, dizziness, nausea, rapid and shallow breathing). Take breaks in cool places and hydrate as needed.</p> <p>1f. Watch for cold stress symptoms (severe shivering, slowing of body movement, weakness, stumbling or inability to walk, collapse). Take breaks in warm areas as needed.</p> <p>1f. Wear clothing appropriate for weather and temperature conditions (e.g., rain jackets, snow pants, multiple layers).</p> <p>1f. If lightning is observed, wait 30 minutes in a sheltered location (car is acceptable) before resuming work.</p> <p>1g. Wear hearing protection if sound levels exceed 85 dBA (if you must raise your voice for normal conversation).</p>

<sup>1</sup> Each Job or Operation consists of a set of tasks / steps. Be sure to list all the steps needed to perform job.

<sup>2</sup> A hazard is a potential danger. Break hazards into six types: Contact - victim is struck by or strikes an object; Caught - victim is caught on, caught in or caught between objects; Fall - victim falls to ground or lower level (includes slips and trips); Exertion - excessive strain or stress / ergonomics / lifting techniques; Exposure - inhalation/skin hazards; Energy Source – electricity, pressure, compression/tension.

<sup>3</sup> Using the first two columns as a guide, decide what actions or procedures are necessary to eliminate or minimize the risk. List the recommended safe operating procedures. Say exactly what needs to be done - such as "use two persons to lift". Avoid general statements such as, "be careful".

<b>JOB SAFETY ANALYSIS</b> Ctrl. No. GEN-017		DATE 8/6/2018	<input type="checkbox"/> NEW <input checked="" type="checkbox"/> REVISED	PAGE 1 of 2
JSA TYPE CATEGORY: <b>GENERIC</b>	WORK TYPE: <b>Drilling</b>	WORK ACTIVITY (Description): <b>Monitoring and Recovery Well Development</b>		
<b>DEVELOPMENT TEAM</b>	<b>POSITION / TITLE</b>	<b>REVIEWED BY:</b>	<b>POSITION / TITLE</b>	
Amy Hoffman	Staff Geologist	Brian Hobbs	Corporate Health & Safety Manager	
Ron Lombino	Staff Geologist			
Courtney Lind	Staff Engineer			
<b>REQUIRED AND / OR RECOMMENDED PERSONAL PROTECTIVE EQUIPMENT</b>				
<input type="checkbox"/> LIFE VEST <input checked="" type="checkbox"/> HARD HAT <input type="checkbox"/> LIFELINE / BODY HARNESS <input checked="" type="checkbox"/> SAFETY GLASSES	<input type="checkbox"/> GOGGLES <input type="checkbox"/> FACE SHIELD <input checked="" type="checkbox"/> HEARING PROTECTION (as needed) <input checked="" type="checkbox"/> SAFETY SHOES: <u>Composite-toe or steel toe boots</u>	<input type="checkbox"/> AIR PURIFYING RESPIRATOR <input type="checkbox"/> SUPPLIED RESPIRATOR <input checked="" type="checkbox"/> PPE CLOTHING: <u>Fluorescent reflective vest or high visibility clothing</u>	<input checked="" type="checkbox"/> GLOVES: <u>Leather or cut-resistant and Nitrile</u> <input checked="" type="checkbox"/> OTHER: <u>Insect repellent, sunscreen (as needed)</u>	
<b>REQUIRED AND / OR RECOMMENDED EQUIPMENT</b>				
Required Equipment as needed: Truck Rig or support truck, Trailer, 42-inch Safety cones and flags, Caution Tape, Interface Probe, Power Source, Submersible Pump, Surge Block/Plunger, 20 lb. Type ABC Fire Extinguisher, Holding Tanks and/or Buckets, Absorbent Pads, 5-gas meter, Tools as needed: Socket and Pipe Wrench, Screw Driver, Pry Bar, Ratchet, Vault Key.				
<b>COMMITMENT TO SAFETY-</b> All personnel onsite will actively participate in hazard recognition and mitigation throughout the day by verbalizing SPSAs				
<b>EXCLUSION ZONE (EZ): Maintain a 20 Foot EZ During Development Activities</b>				
<b>“SHOW ME YOUR HANDS”</b>				
<b>Driller and helper should show that hands are clear from controls and moving parts</b>				
<b>Assess JOB STEPS</b>	<b>Analyze POTENTIAL HAZARDS</b>	<b>Act CRITICAL ACTIONS</b>		
1. Mobilization / Demobilization <b>(Review Mobilization and Demobilization JSA)</b>	1a. <b>CONTACT:</b> Equipment/property damage.  1b. <b>FALL:</b> Slip/trip/fall hazards.	1a. The truck rig's tower/derrick will be lowered and secured prior to mobilization. 1a. Set-up the work area / position equipment in a manner that eliminates or reduces the need for backing of trucks and trailers. 1a. All non-essential personnel should <b>maintain an exclusion zone of 20 feet.</b> 1a. Beep horn twice before backing up. 1a. When backing up with an attached trailer use a spotter Level or avoid if needed. 1b. Inspect walking path for uneven terrain, weather-related hazards (i.e., ice, puddles, snow, etc.), and obstructions prior to mobilizing equipment. 1b. Do not climb over stored materials/equipment; walk around. Store equipment at lowest potential energy.		
2. Open/close well.	2a. <b>EXERTION:</b> Muscle strain (some wells have large vault covers).  2b. <b>CAUGHT:</b> Pinch points associated with removing/replacing manholes and working with hand tools.  2c. <b>EXPOSURE:</b> Potentially hazardous vapors.  2d. <b>CONTACT:</b> Traffic.	2a. Keep back straight, lift with legs, keep load close to body, and never reach with a load. Ensure that loads are balanced to reduce the potential for muscle strain. Two people are required when lifting objects over 50 lbs or when the shape makes the object difficult to lift.  2b. Wear cut-resistant/leather gloves when working with well vault/cover and hand tools. Do not put fingers under well vault/cover. 2b. Use ratchet and pry bar for well cover and inspect before use.  2c. No open flames/heat sources. 2c. Allow well to vent after opening it and before starting development activities to minimize exposure to vapors. Air monitoring must be performed prior to set up and during the well development activities. Work on upwind side of well.  2d. Wear required PPE including high visibility clothing or reflective vest. 2d. Delineate work area with 42" safety cones and/or other barriers. Position vehicle to protect against oncoming traffic. 2d. Face traffic, maintain eye contact with oncoming vehicles, and establish a safe exit route.		

<sup>1</sup> Each Job or Operation consists of a set of tasks / steps. Be sure to list all the steps needed to perform job.

<sup>2</sup> A hazard is a potential danger. Break hazards into six types: Contact - victim is struck by or strikes an object; Caught - victim is caught on, caught in or caught between objects; Fall - victim falls to ground or lower level (includes slips and trips); Exertion - excessive strain or stress / ergonomics / lifting techniques; Exposure - inhalation/skin hazards; Energy Source - Electricity, Pressure, compression, tension, torque.

<sup>3</sup> Using the first two columns as a guide, decide what actions or procedures are necessary to eliminate or minimize the risk. List the recommended safe operating procedures. Say exactly what needs to be done - such as "use two persons to lift". Avoid general statements such as, "be careful".

Assess <sup>1</sup> JOB STEPS	Analyze <sup>2</sup> POTENTIAL HAZARDS	Act <sup>3</sup> CRITICAL ACTIONS
3. Develop well (mechanical surging).	<p><b>3a. CAUGHT:</b> Cut hazards and finger pinch points.</p> <p><b>3b. CONTACT/EXPOSURE:</b> Contamination (e.g., SPH, contaminated groundwater, vapors).</p> <p><b>3c. EXERTION:</b> Muscle strain from lifting equipment.</p> <p><b>3d. CONTACT:</b> Injury while handling wench line/cable, or with active surging equipment.</p>	<p>3a See 2b.</p> <p>3a. Use required PPE including leather/cut-resistant gloves when handling development equipment. Identify finger/hand pinch points. Keep hands away from active surge equipment.</p> <p>3a. All non-essential personnel should <b>maintain an exclusion zone of 20 feet.</b></p> <p>3b. See 2c.</p> <p>3b. Wear Nitrile gloves and safety glasses. Insert and remove surge block/plunger and line/cable slowly to avoid splashing at the surface.</p> <p>3b. Use an absorbent pad to clean any spills.</p> <p>3c. See 2a.</p> <p>3c. Use mechanical device to insert and remove surge block/plunger if greater than 50lb.</p> <p>3d. If using a drill rig, inspect all wench lines/cables for any kinks or if frayed prior to use. Replace any damaged lines/cables. Review <b>Drill Rig checklist prior to development activities.</b></p> <p>3d. See 3a.</p>
4. Purging well (pumping water to holding tanks/drums/buckets).	<p><b>4a. CAUGHT:</b> Pinch points associated with connecting hose to tank. Pinch points associated with handling pump and hoses.</p> <p><b>4b. FALL:</b> Using side mounted ladder when attaching hose to tank.  Slip, trip, fall from lines/hoses</p> <p><b>4c. CONTACT:</b> Contamination (e.g., SPH, contaminated groundwater).</p> <p><b>4d. EXERTION:</b> Muscle strain from lifting/carrying equipment.</p> <p><b>4e. FALL:</b> Spilled purge water.</p>	<p>4a. See 3a.</p> <p>4a. Ensure that fingers are not placed near coupling when attaching and securing hose(s). Do not place fingers under pump/hoses. Wear leather or cut-resistant gloves when handling pump/hose(s).</p> <p>4a. Keep hands clear from any line of fire.</p> <p>4b. Inspect ladder steps to make sure steps are not bent/damaged and free of debris/fluid.</p> <p>4b. Use three points of contact always when using ladder.</p> <p>4b. Use hoist or other mechanical means to secure and move hose.</p> <p>4b. Utilize anti-whip cords on all compressed hoses. Keep hoses and lines coiled and organized out of designated walking paths around the work zone.</p> <p>4c. Secure water hose.</p> <p>4c. Do not overfill tanks, and purge/transfer liquids in such a manner that they do not splash. (See 3b).</p> <p>4c. Dispose of used materials/PPE in the designated impacted PPE container.</p> <p>4d. See 2a.</p> <p>4e. Clean up any spills using absorbent pads or spill kits.</p>
5. Decontaminate equipment	<p><b>5a. CONTACT/EXPOSURE:</b> Contamination (e.g., SPH, contaminated groundwater, vapors).</p> <p><b>5b. EXPOSURE/CONTACT:</b> Chemicals in cleaning solution</p>	<p>5a. See 3b.</p> <p>5b. Decontaminate equipment in well-ventilated area. Wear nitrile gloves to avoid skin contact with cleaning solutions.</p>

<sup>1</sup> Each Job or Operation consists of a set of tasks / steps. Be sure to list all the steps needed to perform job.

<sup>2</sup> A hazard is a potential danger. Break hazards into six types: Contact - victim is struck by or strikes an object; Caught - victim is caught on, caught in or caught between objects; Fall - victim falls to ground or lower level (includes slips and trips); Exertion - excessive strain or stress / ergonomics / lifting techniques; Exposure - inhalation/skin hazards; Energy Source – Electricity, Pressure, compression, tension, torque.

<sup>3</sup> Using the first two columns as a guide, decide what actions or procedures are necessary to eliminate or minimize the risk. List the recommended safe operating procedures. Say exactly what needs to be done - such as "use two persons to lift". Avoid general statements such as, "be careful".

<b>JOB SAFETY ANALYSIS</b>		<b>Ctrl. No. GEN-018</b>	DATE: 1/4/2018	<input type="checkbox"/> NEW <input checked="" type="checkbox"/> REVISED	PAGE 1 of 2
JSA TYPE CATEGORY <b>GENERIC</b>	WORK TYPE <b>Construction</b>	WORK ACTIVITY (Description) : <b>Installing and Working on Scaffolding</b>			
<b>DEVELOPMENT TEAM</b>	<b>POSITION / TITLE</b>	<b>REVIEWED BY:</b>		<b>POSITION / TITLE</b>	
Tom Henderson	Senior Scientist	Brian Hobbs		Corporate Health & Safety Manager	
AJ Clare	Senior Technician				
<b>REQUIRED AND / OR RECOMMENDED PERSONAL PROTECTIVE EQUIPMENT</b>					
<input type="checkbox"/> LIFE VEST <input checked="" type="checkbox"/> HARD HAT <input checked="" type="checkbox"/> LIFELINE / BODY HARNESS <input checked="" type="checkbox"/> SAFETY GLASSES	<input type="checkbox"/> GOGGLES <input type="checkbox"/> FACE SHIELD <input type="checkbox"/> HEARING PROTECTION <input checked="" type="checkbox"/> SAFETY SHOES: <u>Safety-toed boots</u>	<input type="checkbox"/> AIR PURIFYING RESPIRATOR <input type="checkbox"/> SUPPLIED RESPIRATOR <input checked="" type="checkbox"/> PPE CLOTHING: <u>Reflective vest, Long sleeve shirt</u>	<input checked="" type="checkbox"/> GLOVES: <u>Leather, Level 2 Cut Resistant</u> <input checked="" type="checkbox"/> OTHER: <u>Personal Fall Arrest System (PFAS) or Fall Prevention System (PFS)</u>		
<b>REQUIRED AND / OR RECOMMENDED EQUIPMENT</b>					
Required Equipment: Caution tape, 42"-high cones/barricades, scaffolding, ladders, signage, and hand tools.					
<b>COMMITMENT TO SAFETY-</b> All personnel onsite will actively participate in hazard recognition and mitigation throughout the day by verbalizing SPSAs					
<b>EXCLUSION ZONE (EZ): A 10' exclusion zone (EZ) minimum will be maintained around scaffolding and ladders.</b>					
<b>Assess 1JOB STEPS</b>	<b>Analyze 2POTENTIAL HAZARDS</b>	<b>Act 3CRITICAL ACTIONS</b>			
1. Secure work zone.	1a. <b>CONTACT:</b> Struck By pedestrian and/or vehicular traffic entering the work area.  1b. <b>FALL:</b> Slip/trip/fall hazards in EZ.  1c. <b>EXPOSURE:</b> Potential hazardous atmosphere.  1d. <b>ENERGY SOURCE:</b> Electrocutation (if applicable).	1a. Define work <b>EZ of 10' minimum</b> around scaffold construction area excluding equipment staging areas. Expand EZ for tip over distance, if needed. Use 42" cones, barricades, "Caution" tape, and warning signage. Communicate task to surrounding workers. Only designated workers donned with required standard PPE (including Level 2 cut-resistant gloves) allowed entry to EZ.  1b. Remove material and equipment obstructions from walkways and store in designated staging areas.  1c. Conduct air monitoring using direct-reading instruments.  1d. Conduct LO/TO procedures; Engage Public Utility to cover, relocate, or remove overhead electric lines prior to Work Zone entry. Follow HASP and OSHA Standard 1926.451(f)(6) for required specific clearance distances.			
2. Unload scaffolding components.	2a. <b>CONTACT:</b> Lacerations, cuts, and abrasions.  2b. <b>CAUGHT-CRUSHED:</b> Fingers / hands in pinch points.  2c. <b>FALL:</b> Fall from height;  Trip/fall while moving equipment into position.  2d. <b>ERGONOMICS:</b> Strain from moving material into position.	2a. Wear ANSI Level 2 cut resistant gloves if pre-work material inspection yields sharp edges.  2b. Position your fingers/hands where they can't be caught between a lifted load and adjacent objects. Wear leather gloves to protect from pinching/crushing.  2c. Ascend/descend materials from/onto delivery truck-bed using 3-points of contact; If the truck bed does not have a built-in ladder, use an A-frame step ladder of sufficient height that the worker will not need to use the top 2 steps;  2c. Keep materials, scaffolding, and hand tools in designated staging area(s) until needed to avoid clutter and trip hazards.  2d. Use buddy system or lifting-apparatus when lifting materials over 50-lbs. Use proper lifting techniques including straight back, bent knees, load-weight near body, don't reach/extend load away while handling/moving components, avoid twisting.			
3. Inspect scaffolding components prior to set-up.	3a. <b>FALL:</b> From damaged or malfunctioning scaffold components.	3a. Designate <b>Competent Person (CP)</b> for this task: _____ (insert name above). <b>CP responsibilities:</b> <ul style="list-style-type: none"> <li>- Remains on-site for all phases of scaffold work.</li> <li>- Inspects scaffold components including wheels, brakes, connections, pins, framing, platforms, guard rails, and ladders per OSHA 1926 subsection L.</li> <li>- Trains workers to erect the scaffold structure, hazard-recognition, scaffold's safe use, fall prevention / protection, load capacities, falling objects, electrical hazards, access, maintenance, operation, repair, dis-assembly, use of ties/braces, inspection.</li> <li>- Uses only manufacturer-supplied braces and hardware (no substitutions).</li> <li>- Removes damaged components from service.</li> <li>- Tags scaffold to alert workers of its condition.</li> </ul>			

<sup>1</sup> Each Job or Operation consists of a set of tasks / steps. Be sure to list all the steps needed to perform job.

<sup>2</sup> A hazard is a potential danger. Break hazards into six types: Contact - victim is struck by or strikes an object; Caught - victim is caught on, caught in or caught between objects; Fall - victim falls to ground or lower level (includes slips and trips); Exertion - excessive strain or stress / ergonomics / lifting techniques; Exposure - inhalation/skin hazards. Energy Sources-electricity, pressure, compression/tension.

<sup>3</sup> Using the first two columns as a guide, decide what actions or procedures are necessary to eliminate or minimize the risk. List the recommended safe operating procedures. Say exactly what needs to be done - such as "use two persons to lift." Avoid general statements such as, "be careful."

Assess <sup>1</sup> JOB STEPS	Analyze <sup>2</sup> POTENTIAL HAZARDS	Act <sup>3</sup> CRITICAL ACTIONS
4. Scaffold assembly (erecting / moving scaffolding from ground level).	<p><b>4a. CONTACT:</b> STRUCK-BY materials/ tools/ equipment falling from scaffold platform causing bone fractures, lacerations, cuts, abrasions.</p> <p><b>4b. CAUGHT-CRUSHED:</b> Pinch point during scaffold assembly.</p> <p><b>4c. FALL:</b> From Ladder / End-frame / Stair access to platform while ascending / descending</p> <p>Fall due to Elevated Platform Failure</p> <p>Fall from elevation.</p> <p>Fall due to Scaffold failure.</p> <p><b>4d. EXERTION:</b> Muscle strain while moving/lifting materials.</p> <p><b>4e. ENERGY SOURCE:</b> Electrocutation (if applicable)</p>	<p>4a. <b>Maintain 10' EZ</b> minimum or tip-over radius (where possible) around the scaffold erection area; Set up scaffolding on firm, level surfaces. Use leveling jacks to provide stable base and eliminate scaffold movement.</p> <p>4a. Wheeled-base scaffold wheels to remain locked except during relocation. Workers must disembark with tools during repositioning, and then relock wheels.</p> <p>4a. While working over 6ft, ensure that hand tools and equipment are securely tied off using rated rope or a lanyard to prevent contact with ground workers.</p> <p>4a. Use only manufacturer-supplied braces and hardware (no substitutions).</p> <p>4a. When hoisting materials overhead to workers verify rope is free of rips or tears and has appropriate weight rating. Verify materials are securely fastened with rope.</p> <p>4a. Wear required PPE including hard hat, safety glasses, reflective vest, safety-toe boots, long sleeve shirt, PFAS harness with lanyard attached to approved anchor points.</p> <p>4a. Use manufacturer-approved platforms (18"-width minimum) or marked, scaffold-grade planking so that the working platform surface is filled between the front uprights and the guardrails.</p> <p>4a. Gaps between the uprights/platforms/planks not to exceed 1". 4" high toe-boards are required to prevent objects from falling from decking to lower levels.</p> <p>4b. Keep fingers/limbs away from pinch points and frame-work connections during assembly. Wear leather gloves for hand protection.</p> <p>4c. Use ladder / built-in scaffolding end-frame steps / stairs to ascend and descend scaffolding, <b>NOT</b> cross-bracing. Ladders must be inspected, clear scaffolding platform by a 3'-minimum, and be tied-off. Maintain 1:4 slope ratio, 3-points of contact while ascending/descending, with weight centered between rails. Install swing gates at scaffold staircases (if staircases are used).</p> <p>4c. Use only "Scaffold-Grade" marked planking; Planking to overlap frame-work edges 6"-12" <b>only</b>; Install cross braces in all sections except access and material-delivery points; Scaffolding to be tied into work-face for every 30' in elevation; Working platform must be within 14" from work-face.</p> <p>4c. Personal Fall Arrest Systems (PFAS) to be used above 6'; Fall protection anchor point installations (excluding the scaffold being worked from) prioritized after platform assembly and used; Calculate that fully deployed PFAS will not allow user to touch the ground during potential falls.</p> <p>4c. If scaffold tiers are erected above workers <i>and</i> OSHA compliant top-rails (42"), mid-rails (21"), toe-boards (4") are employed, safety harnesses are not required; CP conducts final inspection of completed scaffold structure prior to use verifying correct assembly/securement, pins are in "locked" position.</p> <p>4d. Employ buddy system or lifting-apparatus when lifting materials over 50-lbs; Use proper lifting techniques including straight back, bent knees, load/weight near body, don't reach/extend/twist with load while handling components.</p> <p>4e. Verify that no energy sources (electric wires, cables) either contact scaffolding or come within OSHA/HASP specified distances of workers or scaffold. Use LO/TO to ensure that hazardous energy cannot be transmitted to the conductive scaffold framework prior to assembly.</p>
5. Working on scaffolding.	<p><b>5a. CONTACT:</b> Struck-by objects falling from scaffolding / ladder.</p> <p><b>5b. FALL:</b> Fall from elevation.</p> <p>Fall during scaffold collapse due to overloading.</p> <p>Slip/fall due to slick surfaces.</p>	<p>5a. See JOB STEP 4a; Remove unnecessary tools/materials from scaffolding, returning them to designated staging areas. Inspect work zone for head-knocker and trip hazards.</p> <p>5b. See JOB STEP 4c; <b>CP</b> to conduct daily, pre-work, scaffold inspection; Workers climbing on scaffolding will use 3-points of contact; Ensure PFAS lanyards secured to approved anchor points (excluding the scaffold being worked from, or other scaffold-framework-struts). <b>CP</b> to review manufacturer's weight-loading specifications / restrictions for workers and materials, communicate limitations to the work crew, and periodically verify adherence to the specifications. <b>CP</b> and workers to inspect/assess for slick, wet, or iced (outdoor) surfaces continually during use due to changing conditions, mitigate hazards, and/or restrict access and post warnings.</p>
6. Disassemble scaffolding.	<p><b>6a. CONTACT:</b> Struck-by falling tools / materials.</p> <p><b>6b. FALL:</b> Slip/trip hazards resulting from inadequate house-keeping.</p>	<p>6a. Clear scaffolding of debris, tools, and materials prior to dismantling; Dismantle scaffolding by working backwards from the farthest point towards the access location; Plan/verify a route of egress prior to dismantling.</p> <p>6b. Remove fall protection (mid-rail, top-rail) only after removing cross braces; Ensure that all personnel are aware that the particular tier of scaffolding is being dismantled; If fall protection anchor points have been removed, maintain safe distances from scaffolding platform edges, and only under a Supervisor's observation.</p>

<sup>1</sup> Each Job or Operation consists of a set of tasks / steps. Be sure to list all the steps needed to perform job.

<sup>2</sup> A hazard is a potential danger. Break hazards into six types: Contact - victim is struck by or strikes an object; Caught - victim is caught on, caught in or caught between objects; Fall - victim falls to ground or lower level (includes slips and trips); Exertion - excessive strain or stress / ergonomics / lifting techniques; Exposure - inhalation/skin hazards. Energy Sources-electricity, pressure, compression/tension.

<sup>3</sup> Using the first two columns as a guide, decide what actions or procedures are necessary to eliminate or minimize the risk. List the recommended safe operating procedures. Say exactly what needs to be done - such as "use two persons to lift." Avoid general statements such as, "be careful."

<b>JSA TYPE CATEGORY</b> <b>GENERIC</b>	<b>WORK TYPE</b> <b>Site Recon</b>	<b>WORK ACTIVITY (Description)</b> <b>Site Walk and Inspection</b>		
<b>DEVELOPMENT TEAM</b>	<b>POSITION / TITLE</b>	<b>REVIEWED BY:</b>	<b>POSITION / TITLE</b>	
Sara Barrientos	Staff Geologist	Brian Hobbs	Corporate Health and Safety Manager	
		Joe Duminuco	Vice President	

REQUIRED AND / OR RECOMMENDED PERSONAL PROTECTIVE EQUIPMENT			
<input type="checkbox"/> LIFE VEST <input checked="" type="checkbox"/> HARD HAT <input type="checkbox"/> LIFELINE / BODY HARNESS <input checked="" type="checkbox"/> SAFETY GLASSES	<input type="checkbox"/> GOGGLES <input type="checkbox"/> FACE SHIELD <input checked="" type="checkbox"/> HEARING PROTECTION: ear plugs as necessary <input checked="" type="checkbox"/> SAFETY SHOES: <u>Steel or composite toed</u>	<input type="checkbox"/> AIR PURIFYING RESPIRATOR SUPPLIED <input type="checkbox"/> RESPIRATOR <input checked="" type="checkbox"/> PPE CLOTHING: <u>High-visibility vest or high-vis outerwear</u>	<input checked="" type="checkbox"/> GLOVES: <u>Leather/cut-resistant/chemical resistant</u> <input checked="" type="checkbox"/> OTHER: Tyvek and rubber boots as necessary, dust mask as necessary

**REQUIRED AND / OR RECOMMENDED EQUIPMENT**

Required Equipment: Site map, emergency contact list, documentation of urgent care/hospital routes and / or guide familiar with Site, operating cell phone or walkie-talkie if Site allows.

**Commitment to Safety** – All personnel onsite will actively participate in SPSA performance by verbalizing SPSAs throughout the day.

**EXCLUSION ZONE (EZ): A minimum 10' exclusion zone will be maintained around equipment.**

**SITE SECURITY: Prior to site inspection verify appropriate method to address Site Security concerns as it relates to potential criminal activity, homeless population, and/or isolation concerns. Work with the Project Principal and/or Project Manager to address appropriately.**

Assess <b>1JOB STEPS</b>	Analyze <b>2POTENTIAL HAZARDS</b>	Act <b>3CRITICAL ACTIONS</b>
1. Check in with Site contact.	1a. <b>CONTACT/EXPOSURE/FALL:</b> Personal injury caused by lack of site specific hazards.	1a. Inquire about hazards and other activities taking place at the Site. 1a. Inform Site contact of work scope, timeline and location(s). 1a. Discuss emergency evacuation procedures and muster points with Site contact.
2. Traversing the Site	2a. <b>CONTACT:</b> Property damage and personal injury caused by obstructions/vehicles or unauthorized personnel at remote Sites.  2b. <b>FALL:</b> Uneven terrain and weather conditions. Overgrown shrubs and vines. Equipment in the work zone.  2c. <b>OVEREXERTION:</b> Muscle strain while carrying equipment.  2d. <b>EXPOSURE:</b> Biological hazards – ticks; bees/wasps; poison ivy; insects; (Ticks are most active any time the temperature is above freezing, typically from March to November.)	2a. All equipment must be stowed and secured prior to moving. 2a. Maintain speed limit as posted on-site. 2a. When possible drive on established roadways. 2a. Yield to all pedestrians. 2a. Use pull-through spots or back into parking spots. 2a. Don high visibility clothing/safety vest. If working at remote Site, add orange accessories during hunting season.  2b. Inspect walking path for uneven terrain, weather-related hazards (i.e., ice, puddles, snow, etc.), and obstructions prior to mobilizing equipment. 2b. When possible, use established pathways and walk on stable, secure ground. 2b. Communicate traversing hazards with others.  2c. When carrying equipment to/from work area, use proper lifting techniques; keep back straight, lift with legs, keep load close to body, never reach with a load. Ensure that loads are balanced to reduce the potential for muscle strain. Use mechanical assistance or make multiple trips to carry equipment.  2d. Inspect area to avoid contact with biological hazards. 2d. Ticks: <ul style="list-style-type: none"> <li>Treat outer clothing including pants, shirts, socks, boots and hats the evening before with Permethrin (allowing at least two hours before use).</li> <li>Apply DEET to exposed skin before travelling to the Site and reapply after two hours.</li> <li>Check for ticks during and after work.</li> </ul> 2d. Bees: <ul style="list-style-type: none"> <li>Use bee spray as appropriate to deter/eliminate bees.</li> <li>Protect exposed skin with insect repellent.</li> </ul> 2d. Poison Ivy:

<sup>1</sup> Each Job or Operation consists of a set of tasks / steps. Be sure to list all the steps needed to perform job.  
<sup>2</sup> A hazard is a potential danger. Break hazards into six types: Contact - victim is struck by or strikes an object; Caught - victim is caught on, caught in or caught between objects; Fall - victim falls to ground or lower level (includes slips and trips); Exertion - excessive strain or stress / ergonomics / lifting techniques; Exposure - inhalation/skin hazards; Energy Source – electricity, pressure, compression/tension.  
<sup>3</sup> Using the first two columns as a guide, decide what actions or procedures are necessary to eliminate or minimize the risk. List the recommended safe operating procedures. Say exactly what needs to be done - such as "use two persons to lift". Avoid general statements such as, "be careful".

	<p><b>2e. EXPOSURE:</b> Heat Stress &amp; Cold Stress. Personal injury from working in inclement weather conditions.</p>	<ul style="list-style-type: none"> <li>Identify areas of poison ivy and spray with weed killer. Don Tyvek and rubber boots while traversing poison ivy areas.</li> <li>If skin contacts poison ivy, wash skin thoroughly with soap and water.</li> </ul> <p>2e. Wear sunscreen with SPF 15 or greater on exposed skin whenever 30 minutes or more of sun exposure is expected.</p> <p>2e. Watch for heat stress symptoms (muscle cramping, exhaustion, dizziness, rapid and shallow breathing). Take breaks as needed.</p> <p>2e. Watch for cold stress symptoms (severe shivering, slowing of body movement, weakness, stumbling or inability to walk, collapse). Take breaks as needed.</p> <p>2e. Wear appropriate rain gear as needed.</p> <p>2e. Take frequent breaks if tired, wet, or cold/hot. Drink water.</p> <p>2e. If lightning is observed, wait 30 minutes after last thunder boom/lightning bolt in a sheltered location (car acceptable) before starting work again.</p>
<p>3. Walking near heavy equipment and machinery.</p>	<p><b>3a. CONTACT:</b> Personal injury from Site and roadway traffic. Personal injury from flying debris</p> <p><b>3b. OVEREXERTION:</b> Personal injury from lifting/moving/rotating equipment.</p> <p><b>3c. EXPOSURE:</b> Hearing damage from noise generating equipment/processes. Inhalation/exposure to hazardous vapors and or dust.</p> <p><b>3d. EXPOSURE:</b> Working in a remote area.</p>	<p>3a. See 2a.</p> <p>3a. Maintain an exclusion zone of at least 10'-25' feet from all engaged equipment.</p> <p>3a. Keep body parts out of the line of fire of pinch points.</p> <p>3a. Wear appropriate PPE always.</p> <p>3b. See 2c.</p> <p>3c. Wear hearing protection if &gt;85 dBA. (i.e. noise levels which require you to raise your voice to communicate)</p> <p>3c. Always wear leather gloves when handling any tools or equipment.</p> <p>3c. Always wear appropriate PPE based off chemicals present.</p> <p>3d. Use the "buddy system" whenever possible. If working alone, contact PM upon arrival/departure, as well as during work activities prior to commencing work if applicable.</p> <p>3d. Always carry a communication (i.e., cell phone, walkie-talkie) or directional (i.e., map, compass, etc.) device when traversing remote areas.</p>
<p>4. Working in adverse weather conditions.</p>	<p><b>4a. EXPOSURE:</b> Heat Stress &amp; Cold Stress. Personal injury from working in inclement weather conditions.</p>	<p>4a. Watch for heat stress symptoms (muscle cramping, exhaustion, dizziness, rapid and shallow breathing). Take breaks as needed.</p> <p>4a. Watch for cold stress symptoms (severe shivering, slowing of body movement, weakness, stumbling or inability to walk, collapse). Take breaks as needed.</p> <p>4a. Wear appropriate rain gear as needed.</p> <p>4a. Take frequent breaks if tired, wet, or cold/hot. Drink water.</p> <p>4a. If lightning is observed, wait 30 minutes after last thunder boom/lightning bolt in a sheltered location (car acceptable) before starting work again.</p>
<p>5. Departing Site.</p>	<p><b>5a. EXPOSURE:</b> Exposure to unnecessary hazards should personnel believe Roux is on-Site during an emergency and conduct a search.</p>	<p>5a. Sign out or notify Site contact and Roux Project Manager of your departure.</p>

<sup>1</sup> Each Job or Operation consists of a set of tasks / steps. Be sure to list all the steps needed to perform job.

<sup>2</sup> A hazard is a potential danger. Break hazards into six types: Contact - victim is struck by or strikes an object; Caught - victim is caught on, caught in or caught between objects; Fall - victim falls to ground or lower level (includes slips and trips); Exertion - excessive strain or stress / ergonomics / lifting techniques; Exposure - inhalation/skin hazards; Energy Source - electricity, pressure, compression/tension.

<sup>3</sup> Using the first two columns as a guide, decide what actions or procedures are necessary to eliminate or minimize the risk. List the recommended safe operating procedures. Say exactly what needs to be done - such as "use two persons to lift". Avoid general statements such as, "be careful".



<b>JOB SAFETY ANALYSIS</b> Ctrl. No. GEN-021		DATE: 8/6/2018	<input type="checkbox"/> NEW <input checked="" type="checkbox"/> REVISED	PAGE 1 of 2
JSA TYPE CATEGORY: <b>GENERIC</b>	WORK TYPE <b>Gauging and Sampling</b>	WORK ACTIVITY (Description) <b>Soil Vapor Sampling (Permanent Monitoring Points)</b>		
<b>DEVELOPMENT TEAM</b>	<b>POSITION / TITLE</b>	<b>REVIEWED BY:</b>	<b>POSITION / TITLE</b>	
Jeff Wills	Project Hydrogeologist	Brian Hobbs	Corporate Health and Safety Manager	
Julie Moriarity	Project Scientist			
<b>REQUIRED AND / OR RECOMMENDED PERSONAL PROTECTIVE EQUIPMENT</b>				
<input type="checkbox"/> LIFE VEST <input checked="" type="checkbox"/> HARD HAT <input type="checkbox"/> LIFELINE / BODY HARNESS <input checked="" type="checkbox"/> SAFETY GLASSES	<input type="checkbox"/> GOGGLES <input type="checkbox"/> FACE SHIELD <input type="checkbox"/> HEARING PROTECTION <input checked="" type="checkbox"/> SAFETY SHOES: <u>Steel-toe boots</u>	<input type="checkbox"/> AIR PURIFYING RESPIRATOR <input type="checkbox"/> SUPPLIED RESPIRATOR <input checked="" type="checkbox"/> PPE CLOTHING: <u>Fluorescent reflective vest or high visibility clothing</u>	<input checked="" type="checkbox"/> GLOVES: <u>Cut-resistant &amp; Nitriles</u> <input checked="" type="checkbox"/> OTHER: <u>Bug Spray, Sun Screen, Knee Pads or kneeling pad</u>	
<b>REQUIRED AND / OR RECOMMENDED EQUIPMENT</b>				
9/16" Socket and Wrench, Non-Toxic Clay, Teflon-Lined Tubing, Masterflex Tubing, Air Pump with Low Flow, Dry Cal, Enclosure (Bucket with 2 holes), Helium Gas Canister, Summa Canisters and Flow Controllers, MultiRae Photo Ionization Detector (PID), Helium Detector, Tubing Cutter, 42-inch Safety Cones, Caution Tape or Retractable Cone Bars				
<b>COMMITMENT TO SAFETY-</b> All personnel onsite will actively participate in hazard recognition and mitigation throughout the day by verbalizing SPSAs.				
<b>EXCLUSION ZONE (EZ): A 5-foot exclusion zone will be maintained for non-essential personnel.</b>				

<sup>1</sup> Each Job or Operation consists of a set of tasks / steps. Be sure to list all the steps needed to perform job.

<sup>2</sup> A hazard is a potential danger. Break hazards into six types: Contact - victim is struck by or strikes an object;

Caught - victim is caught on, caught in or caught between objects; Fall - victim falls to ground or lower level (includes slips and trips); Exertion - excessive strain or stress / ergonomics / lifting techniques; Exposure - inhalation/skin hazards; Energy Source - Electricity, pressure, tension/compression, torque.

<sup>3</sup> Using the first two columns as a guide, decide what actions or procedures are necessary to eliminate or minimize the risk. List the recommended safe operating procedures. Say exactly what needs to be done - such as "use two persons to lift". Avoid general statements such as, "be careful".

Assess 1JOB STEPS	Analyze 2POTENTIAL HAZARDS	Act 3CRITICAL ACTIONS
<p>1. Define and secure work area.</p>	<p><b>1a. FALL:</b> Potential tripping hazards.</p> <p><b>1b. CONTACT:</b> Potential contact with moving vehicles or pedestrians.</p> <p><b>1c. EXERTION:</b> Muscle strain while lifting and carrying equipment.</p>	<p>1a. Ensure work area is secure and inform others (third party) of work activity.</p> <p>1a. Remove tripping hazards and inspect walking path for uneven terrain, weather-related hazards (i.e., ice, puddles, snow, etc.), and obstructions prior to mobilizing equipment.</p> <p>1b. If working alongside roads, look both ways before entering roadways, face traffic, and utilize work vehicle to protect employees.</p> <p>1b. Delineate work area (including vehicles) with traffic safety cones and caution tape or retractable cone bars.</p> <p>1b. Maintain a 5-foot exclusion zone.</p> <p>1b. Wear high visibility clothing or reflective safety vest.</p> <p>1c. When carrying equipment to/from work area, keep back straight, lift with legs, keep load close to body, never reach with a load. Ensure that loads are balanced. Use mechanical assistance/make multiple trips to carry equipment.</p>

<sup>1</sup> Each Job or Operation consists of a set of tasks / steps. Be sure to list all the steps needed to perform job.

<sup>2</sup> A hazard is a potential danger. Break hazards into six types: Contact - victim is struck by or strikes an object; Caught - victim is caught on, caught in or caught between objects; Fall - victim falls to ground or lower level (includes slips and trips); Exertion - excessive strain or stress / ergonomics / lifting techniques; Exposure - inhalation/skin hazards; Energy Source - Electricity, pressure, tension/compression, torque.

<sup>3</sup> Using the first two columns as a guide, decide what actions or procedures are necessary to eliminate or minimize the risk. List the recommended safe operating procedures. Say exactly what needs to be done - such as "use two persons to lift". Avoid general statements such as, "be careful".

Assess 1JOB STEPS	Analyze 2POTENTIAL HAZARDS	Act 3CRITICAL ACTIONS
2. Remove well cover / close well cover.	<p><b>2a. CONTACT/CAUGHT:</b> Pinch points and scrapes associated with hand tools and well covers.</p> <p><b>2b. FALL:</b> Potential tripping hazards associated with installing bolts.</p> <p><b>2c. EXERTION:</b> Physical exertion to remove bolts that were over torqued or stripped.</p>	<p>2a. Keep hands away from pinch points.</p> <p>2a. Use hand tools with extensions to remove and replace well covers.</p> <p>2a. Wear cut-resistant gloves.</p> <p>2a. Use knee pads or kneeling pad when repetitive kneeling on rough ground is anticipated.</p> <p>2b. Place security bolts in secure location so not to create tripping hazards. Replace security bolts so that they fit flush with monitoring well covers.</p> <p>2c. Replace any security bolts that show signs of stripping. Do not over tighten.</p> <p>2c. Use body positioning and bending techniques that minimize muscle strain; keep back straight, bend at the knees.</p> <p>2c. See 2a.</p>
3. Screen vapor point with PID.	<p><b>3a. FALL:</b> Potential tripping hazards associated with equipment.</p> <p><b>3b. EXPOSURE:</b> Inhalation of soil vapor</p>	<p>3a. Place equipment in one area close to the sampling location.</p> <p>3b. Identify area where equipment is to be stored within the work area (away from main walking path).</p> <p>3a. Don't leave equipment on the ground. Return equipment to storage area between uses.</p> <p>3b. Replace brass caps immediately upon completion to avoid soil vapors migrating to the surface through sample tubing.</p> <p>3b. Stand upwind of sample point during screening activities.</p>
4. Remove / replace brass caps at the end of the sample tubing.	<p><b>4a. CONTACT:</b> Pinch points associated with hand tools and brass caps.</p> <p><b>4b. EXPOSURE:</b> Potential pathway for vapors to migrate to land surface.</p>	<p>4a. Use wrench to remove and replace brass caps.</p> <p>4a. Wear cut-resistant gloves to protect against pinch points and scrapes.</p> <p>4b. See 3b.</p> <p>4b. Stand up wind of sample point location.</p>
5. Set up soil vapor sampling equipment and calibration of meters.	<p><b>5a. FALL:</b> Potential tripping hazards associated with equipment and tubing.</p> <p><b>5b. CONTACT:</b> Pinch points associated with handling equipment.</p> <p><b>5c. EXPOSURE:</b> Inhalation of calibration gas and helium.</p>	<p>5a. See 3a.</p> <p>5a. Keep tubing slack to a minimum and locate the summa canister as close to the sampling location as possible.</p> <p>5a. Avoid stepping over equipment and tubing.</p> <p>5b. Do not place fingers/hands under sampling equipment.</p> <p>5b. Make multiple trips when unloading equipment in work area.</p> <p>5b. Wear cut-resistant gloves to protect against pinch points while handling sampling equipment.</p> <p>5c. Review SDS for each type of calibration gas used before calibrating.</p> <p>5c. Calibrate meters in a well-ventilated area and keep air flow regulator away from face.</p> <p>5c. Close valve on canisters after use to avoid inhalation of excess helium or calibration gas.</p> <p>5c. Stand up wind of bucket during helium tracer gas test.</p>

<sup>1</sup> Each Job or Operation consists of a set of tasks / steps. Be sure to list all the steps needed to perform job.

<sup>2</sup> A hazard is a potential danger. Break hazards into six types: Contact - victim is struck by or strikes an object; Caught - victim is caught on, caught in or caught between objects; Fall - victim falls to ground or lower level (includes slips and trips); Exertion - excessive strain or stress / ergonomics / lifting techniques; Exposure - inhalation/skin hazards; Energy Source - Electricity, pressure, tension/compression, torque.

<sup>3</sup> Using the first two columns as a guide, decide what actions or procedures are necessary to eliminate or minimize the risk. List the recommended safe operating procedures. Say exactly what needs to be done - such as "use two persons to lift". Avoid general statements such as, "be careful".

Assess <sup>1</sup> JOB STEPS	Analyze <sup>2</sup> POTENTIAL HAZARDS	Act <sup>3</sup> CRITICAL ACTIONS
6. Cleaning Work Area.	<p><b>6a. FALL:</b> Potential tripping hazards associated with equipment and tubing.</p> <p><b>6b. CONTACT:</b> Storing and transport of equipment in car.</p>	<p>6a. See 3a. 6a. See 3b.</p> <p>6b. Ensure that equipment is placed securely in the vehicle. Do not stack equipment on top of each other. Secure equipment so that it will not slide while being transported.</p> <p>6b. Wear cut-resistant gloves while handling/loading equipment.</p>

<sup>1</sup> Each Job or Operation consists of a set of tasks / steps. Be sure to list all the steps needed to perform job.

<sup>2</sup> A hazard is a potential danger. Break hazards into six types: Contact - victim is struck by or strikes an object; Caught - victim is caught on, caught in or caught between objects; Fall - victim falls to ground or lower level (includes slips and trips); Exertion - excessive strain or stress / ergonomics / lifting techniques; Exposure - inhalation/skin hazards; Energy Source – Electricity, pressure, tension/compression, torque.

<sup>3</sup> Using the first two columns as a guide, decide what actions or procedures are necessary to eliminate or minimize the risk. List the recommended safe operating procedures. Say exactly what needs to be done - such as "use two persons to lift". Avoid general statements such as, "be careful".

JOB SAFETY ANALYSIS		Ctrl. No. GEN-022	DATE 8/6/2018	<input type="checkbox"/> NEW <input checked="" type="checkbox"/> REVISED	PAGE 1 of 2
JSA TYPE CATEGORY: <b>General</b>	WORK TYPE: <b>Drilling</b>	WORK ACTIVITY (Description): <b>Rotosonic Soil Borings / Well Installation</b>			
DEVELOPMENT TEAM	POSITION / TITLE	REVIEWED BY:	POSITION / TITLE		
William Poupis	Vice President ADT	Brian Hobbs	Corporate Health & Safety Manager		
Amy Hoffmann	Project Geologist				
REQUIRED AND / OR RECOMMENDED PERSONAL PROTECTIVE EQUIPMENT					
<input type="checkbox"/> LIFE VEST <input checked="" type="checkbox"/> HARD HAT <input type="checkbox"/> LIFELINE / BODY HARNESS <input checked="" type="checkbox"/> SAFETY GLASSES	<input type="checkbox"/> GOGGLES <input type="checkbox"/> FACE SHIELD <input checked="" type="checkbox"/> HEARING PROTECTION: (as needed) <input checked="" type="checkbox"/> SAFETY SHOES <u>steel or composite toe</u>	<input type="checkbox"/> AIR PURIFYING RESPIRATOR <input type="checkbox"/> SUPPLIED RESPIRATOR <input checked="" type="checkbox"/> PPE CLOTHING: <u>fluorescent long sleeve shirt or long sleeve shirt and reflective safety vest.</u>	<input checked="" type="checkbox"/> GLOVES: Leather, Nitrile and cut resistant <input checked="" type="checkbox"/> OTHER: Insect Repellent, sunscreen (as needed)		
REQUIRED AND / OR RECOMMENDED EQUIPMENT					
Truck-Mounted Sonic Drilling Rig or Mini Sonic Rig, Hand Tools, Photoionization Detector, Multi-Gas Meter (or equivalent), Interface Probe, 20 lb. Type ABC Fire Extinguisher, 42" Cones & Flags, "Work Area" Signs, Water					
<b>COMMITMENT TO SAFETY-</b> All personnel onsite will actively participate in hazard recognition and mitigation throughout the day by verbalizing SPSAs					
<b>EXCLUSION ZONE (EZ): A minimum 10' exclusion zone will be maintained around equipment.</b>					
"SHOW ME YOUR HANDS" Driller and helper should show that hands are clear from controls and moving parts					
Assess <sup>1</sup> JOB STEPS	Analyze <sup>2</sup> POTENTIAL HAZARDS	Act <sup>3</sup> CRITICAL ACTIONS			
1. Mobilization of drilling rig (ensure the Subsurface Clearance Protocol and Drill Rig Checklist are completed).  <b>See also Mobilization/Demobilization JSA.</b>	1a. <b>CONTACT/CRUSH:</b> Equipment/property damage during movement. Crush point between moving rig and other objects.  1b. <b>FALL:</b> Slip/trip/fall hazards.	1a. The drill rig's tower/derrick will be lowered and secured prior to mobilization.  1a. A spotter should be utilized while moving the drill rig or backing operations. If personnel move into the path of the drill rig, the drill rig will be stopped until the path is again clear.  1a. Set-up the work area and position equipment in a manner that eliminates or reduces the need for backing of support trucks and trailers.  1a. When backing up truck rig with an attached trailer use a second spotter if there is tight clearance simultaneously on multiple sides of the equipment or if turning angles limit driver/spotter visibility.  1a. Inspect the driving path for uneven terrain. Level or avoid if needed.  1a. Drill rig should have a <b>minimum exclusion zone of 10 feet</b> for non-essential personnel (i.e., geologist) when the rig is moving/in operation.  1b. Inspect walking path for uneven terrain, weather-related hazards (i.e., ice, puddles, snow, etc.), and obstructions prior to mobilizing equipment.  1b. Do not climb over stored materials/equipment; walk around. Practice good housekeeping.  1b. Use established pathways and walk on stable, secure ground.			
2. Raising tower/derrick of drill rig.	2a. <b>CONTACT:</b> Overhead hazards.  2b. <b>CONTACT:</b> Amputation points when raising the rig and instability of rig.	2a. Prior to raising the tower/derrick, the area above the drilling rig will be inspected for overhead utilities, tree limbs, piping, or other structures, that could come in contact with the rig's tower and/or drilling rods or tools.  2a. Site requirements for raising a tower/derrick around overhead utilities must be reviewed prior to drilling. Maintain a <b>minimum distance of 10 feet</b> from overhead structures.  2a. The tower/derrick must not be raised beneath overhead power lines unless approved by both the Roux and Project PMs.  2b. Inspect the equipment prior to use and avoid amputation points when engaging tower/derrick.  2b. Lower outriggers to ensure stability prior to raising rig tower/derrick.  2b. If the rig needs to be mounted, be sure to use three points of contact.			

<sup>1</sup> Each Job or Operation consists of a set of tasks / steps. Be sure to list all the steps needed to perform job.

<sup>2</sup> A hazard is a potential danger. Break hazards into six types: Contact - victim is struck by or strikes an object; Caught - victim is caught on, caught in or caught between objects; Fall - victim falls to ground or lower level (includes slips and trips); Exertion - excessive strain or stress / ergonomics / lifting techniques; Exposure - inhalation/skin hazards. Energy Source - electricity, pressure, compression/tension.

<sup>3</sup> Using the first two columns as a guide, decide what actions or procedures are necessary to eliminate or minimize the risk. List the recommended safe operating procedures. Say exactly what needs to be done - such as "use two persons to lift". Avoid general statements such as, "be careful".

Assess <sup>1</sup> JOB STEPS	Analyze <sup>2</sup> POTENTIAL HAZARDS	Act <sup>3</sup> CRITICAL ACTIONS
<p>3. Advancement of soil boring and well installation.</p> <p><b>See also Soil Sampling JSA.</b></p>	<p><b>3a. CONTACT:</b> Flying debris.</p> <p><b>3b. EXPOSURE:</b> Noise and dust.</p> <p><b>3c. CAUGHT:</b> Limb/extremity amputation points; abrasion/crushing.</p> <p><b>3d. CONTACT/CRUSH:</b> Crushed between equipment due to imbalance during advancement of drill equipment.</p> <p><b>3e. EXPOSURE:</b> Inhalation of contamination/vapors.</p> <p><b>3f. FALL:</b> Slip/trip/fall hazards.</p> <p><b>3g. EXERTION:</b> Potential for muscle strain/injury while installing well casings and/or lifting sonic rods/casings.</p>	<p>3a. Be aware of and avoid potential lines of fire and wear required PPE such as eye, ear, and hand protection.</p> <p>3b. Wet borehole area with sprayer to minimize dust.</p> <p>3b. Stand upwind and keep body away from rig.</p> <p>3b. Dust mask should be worn if there is visible dust in the breathing zone.</p> <p>3b. Wear hearing protection when the drill rig is in operation.</p> <p>3c. Always wear leather gloves when making connections and using hand tools; wear cut-resistant (i.e., Kevlar) gloves when handling cutting tools.</p> <p>3c. Inspect the equipment prior to use for potential amputation points. Keep hands away from being between connections and use of tools is preferable compared to fingers and hands.</p> <p>3c. Inspect drill head for worn surface or missing teeth; replace if damaged or blunt.</p> <p>3c. Ensure all jewelry is removed, loose clothing is secured, and PPE is secured close to the body.</p> <p>3c. All non-essential personnel should remain outside the heavy equipment exclusion zone that is at least as far as the boom is high (<b>minimum exclusion zone of 10 feet</b>).</p> <p>3c. Drillers and helpers will understand and use the "Show Me Your Hands" Policy. Operator and helpers will remain a <b>minimum of 3 feet</b> from augers/drill rods while in operation.</p> <p>3d. Drillers will advance the borehole with caution to avoid causing the rig to become imbalanced and/or tip.</p> <p>3d. The blocking and leveling devices used to secure the rig will be inspected by drillers and Roux personnel regularly to see if shifting has occurred.</p> <p>3d. In addition, personnel and equipment that are non-essential to the advancement of the borehole will be positioned away from the rig at a distance that is at least as far as the boom is high (<b>minimum exclusion zone of 10 feet</b>).</p> <p>3e. Air monitoring using a calibrated photoionization detector (PID) will be used to periodically monitor the breathing zone of the work area.</p> <p>3e. If readings of &gt;5ppm is recorded, the Roux field personnel must temporarily cease work, instruct all Site personnel to step away from the area of elevated readings and inform the Roux PM of the condition. The Roux PM will then recommend additional precautions in accordance with the site-specific health and safety plan.</p> <p>3f. Contain drill cuttings and drilling water to prevent slip/trip/fall hazards from developing in work area.</p> <p>3f. See 1b.</p> <p>3g. Keep back straight and bend at the knees.</p> <p>3g. Utilize team lifting for objects over 50lbs.</p> <p>3g. Use mechanical lifting device for odd shaped objects.</p>
<p>4. Decontaminate equipment.</p>	<p><b>4a. EXPOSURE:</b> Contamination (e.g., Separate Phase Hydrocarbons (SPH), contaminated groundwater, vapors, chemical in cleaning supplies).</p>	<p>4a. Wear chemical-resistant gloves and safety glasses.</p> <p>4a. Contain decontamination water so that it does not spill.</p> <p>4a. Use an absorbent pad to clean spills, if necessary.</p> <p>4a. See 3b.</p>

<sup>1</sup> Each Job or Operation consists of a set of tasks / steps. Be sure to list all the steps needed to perform job.

<sup>2</sup> A hazard is a potential danger. Break hazards into six types: Contact - victim is struck by or strikes an object;

Caught - victim is caught on, caught in or caught between objects; Fall - victim falls to ground or lower level (includes slips and trips); Exertion - excessive strain or stress / ergonomics / lifting techniques; Exposure - inhalation/skin hazards. Energy Source – electricity, pressure, compression/tension.

<sup>3</sup> Using the first two columns as a guide, decide what actions or procedures are necessary to eliminate or minimize the risk. List the recommended safe operating procedures. Say exactly what needs to be done - such as "use two persons to lift". Avoid general statements such as, "be careful".

<b>JOB SAFETY ANALYSIS</b>		<b>Ctrl. No. GEN-023</b>	DATE: 8/6/2018	<input type="checkbox"/> NEW <input checked="" type="checkbox"/> REVISED	PAGE 1 of 2
JSA TYPE CATEGORY <b>Generic</b>	WORK TYPE <b>Construction</b>	WORK ACTIVITY (Description) <b>Spotting Heavy Machinery</b>			
DEVELOPMENT TEAM	POSITION / TITLE	REVIEWED BY:	POSITION / TITLE		
Levi Curnutte	Project Scientist	Brian Hobbs	Corporate Health & Safety Manager		
<b>REQUIRED AND / OR RECOMMENDED PERSONAL PROTECTIVE EQUIPMENT</b>					
<input type="checkbox"/> LIFE VEST <input checked="" type="checkbox"/> HARD HAT <input checked="" type="checkbox"/> LONG SLEEVED SHIRT <input type="checkbox"/> LIFELINE / BODY HARNESS <input checked="" type="checkbox"/> SAFETY GLASSES	<input type="checkbox"/> GOGGLES <input type="checkbox"/> FACE SHIELD <input type="checkbox"/> HEARING PROTECTION <input checked="" type="checkbox"/> SAFETY SHOES: <u>Steel-/Composite-toe boots/shoes</u>	<input type="checkbox"/> Particulate Respirator <input type="checkbox"/> SUPPLIED RESPIRATOR <input checked="" type="checkbox"/> PPE CLOTHING: <u>Fluorescent reflective clothing</u>	<input checked="" type="checkbox"/> GLOVES: <u>Cut resistant / leather</u> <input type="checkbox"/> OTHER:		
<b>REQUIRED AND / OR RECOMMENDED EQUIPMENT</b>					
Heavy Machinery (i.e. excavator, payloader, truck, forklift, etc.)					
<b>COMMITMENT TO SAFETY-</b> All personnel onsite will actively participate in hazard recognition and mitigation throughout the day by verbalizing SPSAs					
<b>EXCLUSION ZONE (EZ):</b> A 10-foot exclusion zone will be maintained around heavy equipment. Larger equipment with an increased operating or tip-over radius may need a larger exclusion zone. This should be defined prior to operating each piece of equipment					
<b>Assess 1JOB STEPS</b>	<b>Analyze 2POTENTIAL HAZARDS</b>	<b>Act 3CRITICAL ACTIONS</b>			
1. Prepare for machine activity.	1a. <b>CONTACT:</b> Obstructions in the work area may create contact hazards from machinery.  1b. <b>Fall :</b> Slip/Trip/Fall	1a. Cordon off the work area with safety barrels/cones and a rigid barrier (snow fence, traffic bar, etc.). Communicate that only necessary personnel should be in the work area. Spotter and equipment operator shall enforce the <b>10-ft (exclusion zone) EZ</b> . Operator will not operate but shall remain in the hands-off mode while personnel are within the exclusion zone.  1b. Ensure that work area is flat, level and clear of any obstructions or debris before setting up work zone.			
2. Spotting.	2a. <b>CONTACT:</b> Machine or load contact with personnel, property, or machinery.	2a. Discuss the specifics of the work with the operator and be clear about any hand signals that will be used. Clearly discuss the limits of the assigned work area and the machine's Exclusion Zone. Maintain Exclusion Zone. The Exclusion Zone shall be delineated by using 42-inch traffic cones/barrels and a fixed rigid barrier.  2a. The Minimum Heavy Equipment Exclusion zone is 10ft. if it is a larger piece of equipment or has an increased swing or tip-over radius the exclusion zone will need to be increased to accommodate the full range of motion.  2a. Both the spotter and equipment operators shall have 2-way radios/cellular devices on their persons to ensure audible communication in the event any changes or new hazards may arise.  2a. All workers should stay outside of the Exclusion Zone of all equipment unless operator is stopped and in "Hands Off" mode. <b>(This includes the spotter unless an exception has been established in the Site-specific JSA)</b> . If the Exclusion Zone must be reduced due to work area restrictions then the spotter and operator shall enforce the reduced Exclusion Zone.  2a. Spotters must make eye contact with the machine operator or all movement ceases until visual contact can be reestablished.  2a. Spotter shall keep an eye out for any issues with the machine the operator may not see and communicate with other work crews and spotters on behalf of the operator.  2a. If the spotter needs to take a break, he must find a replacement before leaving or have the machine stop operations. <b>No heavy equipment shall operate without a spotter under any circumstances.</b>  2a. Wear fluorescent clothing/safety vest.			

<sup>1</sup> Each Job or Operation consists of a set of tasks / steps. Be sure to list all the steps needed to perform job.

<sup>2</sup> A hazard is a potential danger. Break hazards into six types: Contact - victim is struck by or strikes an object; Caught - victim is caught on, caught in or caught between objects; Fall - victim falls to ground or lower level (includes slips and trips); Exertion - excessive strain or stress / ergonomics / lifting techniques; Exposure - inhalation/skin hazards; Energy Source - electricity, pressure, compression/tension.

<sup>3</sup> Using the first two columns as a guide, decide what actions or procedures are necessary to eliminate or minimize the risk. List the recommended safe operating procedures. Say exactly what needs to be done - such as "use two persons to lift". Avoid general statements such as, "be careful".

Assess <sup>1</sup> JOB STEPS	Analyze <sup>2</sup> POTENTIAL HAZARDS	Act <sup>3</sup> CRITICAL ACTIONS
	<p><b>2b. FALL:</b> Slip/Trip/Fall</p> <p><b>2c. CAUGHT:</b> Caught between machinery and nearby objects.</p> <p><b>2d. EXPOSURE:</b> Inhalation of exhaust from machinery.</p>	<p>2b. Look where walking to identify and avoid slip/trip/fall hazards. Avoid icy and/or wet surfaces. Remove obstacles if possible. 2b. Use designated walkways during spotting whenever possible.</p> <p>2c. <b>Maintain Exclusion Zone.</b> Do not stand between large, loose or fixed objects or structures and the machinery while it is in motion. Keep in sight of operator at all times while being aware of surrounding structures.</p> <p>2d. The spotter will position him/herself upwind of the working machinery, when possible. Spotter will also inform others working within the vicinity of the EZ of proper positioning, if applicable.</p>

<sup>1</sup> Each Job or Operation consists of a set of tasks / steps. Be sure to list all the steps needed to perform job.

<sup>2</sup> A hazard is a potential danger. Break hazards into six types: Contact - victim is struck by or strikes an object; Caught - victim is caught on, caught in or caught between objects; Fall - victim falls to ground or lower level (includes slips and trips); Exertion - excessive strain or stress / ergonomics / lifting techniques; Exposure - inhalation/skin hazards.

<sup>3</sup> Using the first two columns as a guide, decide what actions or procedures are necessary to eliminate or minimize the risk. List the recommended safe operating procedures. Say exactly what needs to be done - such as "use two persons to lift". Avoid general statements such as, "be careful".



<b>JOB SAFETY ANALYSIS</b>		<b>Ctrl. No. GEN-025</b>	DATE: 8/6/2018	<input type="checkbox"/> NEW <input checked="" type="checkbox"/> REVISED	PAGE 1 of 1
JSA TYPE CATEGORY <b>Generic</b>		WORK TYPE <b>General</b>		WORK ACTIVITY (Description) <b>Trucking</b>	
DEVELOPMENT TEAM		POSITION / TITLE		REVIEWED BY:	POSITION / TITLE
Lauren Dolginko		Project Geologist		Brian Hobbs	Corporate Health & Safety Manager
<b>REQUIRED AND / OR RECOMMENDED PERSONAL PROTECTIVE EQUIPMENT</b>					
<input type="checkbox"/> LIFE VEST <input checked="" type="checkbox"/> HARD HAT <input type="checkbox"/> LONG SLEEVED SHIRT <input type="checkbox"/> LIFELINE / BODY HARNESS <input checked="" type="checkbox"/> SAFETY GLASSES		<input type="checkbox"/> GOGGLES <input type="checkbox"/> FACE SHIELD <input type="checkbox"/> HEARING PROTECTION <input checked="" type="checkbox"/> SAFETY SHOES: <u>Steel-toe boots</u>		<input type="checkbox"/> AIR PURIFYING RESPIRATOR <input type="checkbox"/> SUPPLIED RESPIRATOR <input checked="" type="checkbox"/> PPE CLOTHING: <u>Fluorescent reflective vest or high visibility long sleeved clothing</u>	
				<input checked="" type="checkbox"/> GLOVES: <u>Leather or cut resistant</u> <input type="checkbox"/> OTHER	
<b>REQUIRED AND / OR RECOMMENDED EQUIPMENT</b>					
Heavy equipment (i.e. trucks)					
<b>COMMITMENT TO SAFETY</b> - All personnel onsite will actively participate in Hazard recognition and mitigation throughout the day by verbalizing SPSAs.					
<b>EXCLUSION ZONE: A 10' minimum exclusion zone will be maintained around excavator, backhoe, dump trucks and other heavy equipment.</b>					
<b>Assess JOB STEPS</b>	<b>Analyze POTENTIAL HAZARDS</b>	<b>Act CRITICAL ACTIONS</b>			
1. Set up work zone.	1a. <b>CONTACT:</b> Personal injury/property damage caused by obstruction/vehicle.	1a. Establish work zone for manifesting/paperwork by communicating with workers before task begins. Maintain a <b>10 ft Exclusion Zone (EZ)</b> around all heavy equipment.			
2. Loading of truck.	2a. <b>CONTACT:</b> Rolling Vehicle could cause bodily harm.  2b. <b>CONTACT:</b> Machine or load may crush personnel, property or machinery.  2c. <b>CONTACT:</b> Load shifting during travel.	2a. All commercial vehicles without an operator must have their engines off and wheels chocked. Truck and loading area should be on level ground. 2b. All machines (Excavator, Lull, Backhoe) must have a spotter. Spotter must communicate contact hazards such as other personnel in the work area, objects in the machine's blind spot, and overhead lines to the operator. Spotter and operator should have 2-way radios or established hand signals to communicate when needed. 2b. Loads must not be swung over other vehicles or personnel. 2b. Maintain <b>10ft EZ</b> around all equipment. 2c. Secure all loads prior to moving the truck with chains or straps or cribbing. 2c. Any loose soil or debris should be cleaned off truck sides prior to truck mobilization. 2c. All truck beds must be secured prior to traveling.			
3. Dumping loads.	3a. <b>CONTACT:</b> Truck may flip sideways or backwards.	3a. All workers must stay behind and away from the side of trucks that are dumping to avoid contact with the truck potentially tipping sideways or backwards. EZ must be maintained equal to the height of bed while lifted.			
4. Exchanging paperwork with truck driver.	4a. <b>CONTACT/CAUGHT:</b> Broken bones from contact by vehicle.  4b. <b>FALL:</b> Slip, Trip or Fall may cause muscle strains or tears, abrasions or lacerations, or broken bones.	4a. Truck driver should exit truck with proper PPE and enter the established work zone to complete paperwork. If Site-specific safety prohibits drivers from exiting the truck, wait until truck is finished loading, with engine turned off, before approaching truck. 4a. Always establish eye contact with driver prior to approaching truck. 4a. Confirm sides of truck have been cleaned/brushed off prior to approaching truck. 4b. Survey walking route to identify slip/trip/fall hazards. Avoid icy/wet surfaces. Remove slip/trip/fall hazards if present. 4b. Communicate with driver and spotter prior to approaching truck. Maintain a <b>10 ft EZ</b> around all heavy equipment.			

<sup>1</sup> Each Job or Operation consists of a set of tasks / steps. Be sure to list all the steps needed to perform job.

<sup>2</sup> A hazard is a potential danger. Break hazards into six types: Contact - victim is struck by or strikes an object; Caught - victim is caught on, caught in or caught between objects; Fall - victim falls to ground or lower level (includes slips and trips); Exertion - excessive strain or stress / ergonomics / lifting techniques; Exposure - inhalation/skin hazards, energy source; Energy Source - electricity, pressure, compression/tension.

<sup>3</sup> Using the first two columns as a guide, decide what actions or procedures are necessary to eliminate or minimize the risk. List the recommended safe operating procedures. Say exactly what needs to be done - such as "use two persons to lift". Avoid general statements such as, "be careful".

**Site-Specific Health and Safety Plan**  
***The Peninsula Redevelopment Project***  
***1221 Spofford Avenue, Bronx, New York***

---

**APPENDIX B**

SDSs for Chemicals Used

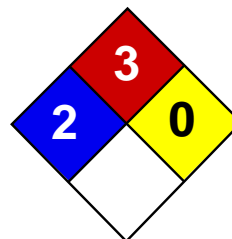

Health	2
Fire	3
Reactivity	0
Personal Protection	H

## Material Safety Data Sheet Benzene MSDS

### Section 1: Chemical Product and Company Identification

**Product Name:** Benzene

**Catalog Codes:** SLB1564, SLB3055, SLB2881

**CAS#:** 71-43-2

**RTECS:** CY1400000

**TSCA:** TSCA 8(b) inventory: Benzene

**CI#:** Not available.

**Synonym:** Benzol; Benzine

**Chemical Name:** Benzene

**Chemical Formula:** C6-H6

**Contact Information:**

**Sciencelab.com, Inc.**

14025 Smith Rd.

Houston, Texas 77396

US Sales: **1-800-901-7247**

International Sales: **1-281-441-4400**

Order Online: [ScienceLab.com](http://ScienceLab.com)

**CHEMTREC (24HR Emergency Telephone), call:**

1-800-424-9300

**International CHEMTREC, call:** 1-703-527-3887

**For non-emergency assistance, call:** 1-281-441-4400

### Section 2: Composition and Information on Ingredients

**Composition:**

Name	CAS #	% by Weight
Benzene	71-43-2	100

**Toxicological Data on Ingredients:** Benzene: ORAL (LD50): Acute: 930 mg/kg [Rat]. 4700 mg/kg [Mouse]. DERMAL (LD50): Acute: >9400 mg/kg [Rabbit]. VAPOR (LC50): Acute: 10000 ppm 7 hours [Rat].

### Section 3: Hazards Identification

**Potential Acute Health Effects:**

Very hazardous in case of eye contact (irritant), of inhalation. Hazardous in case of skin contact (irritant, permeator), of ingestion. Inflammation of the eye is characterized by redness, watering, and itching.

**Potential Chronic Health Effects:**

**CARCINOGENIC EFFECTS:** Classified A1 (Confirmed for human.) by ACGIH, 1 (Proven for human.) by IARC. **MUTAGENIC EFFECTS:** Classified POSSIBLE for human. Mutagenic for mammalian somatic cells. Mutagenic for bacteria and/or yeast. **TERATOGENIC EFFECTS:** Not available. **DEVELOPMENTAL TOXICITY:** Classified Reproductive system/toxin/female [POSSIBLE]. The substance is toxic to blood, bone marrow, central nervous system (CNS). The substance may be toxic to liver, Urinary System. Repeated or prolonged exposure to the substance can produce target organs damage.

### Section 4: First Aid Measures

**Eye Contact:**

Check for and remove any contact lenses. In case of contact, immediately flush eyes with plenty of water for at least 15 minutes. Cold water may be used. WARM water MUST be used. Get medical attention immediately.

**Skin Contact:**

In case of contact, immediately flush skin with plenty of water. Cover the irritated skin with an emollient. Remove contaminated clothing and shoes. Wash clothing before reuse. Thoroughly clean shoes before reuse. Get medical attention.

**Serious Skin Contact:**

Wash with a disinfectant soap and cover the contaminated skin with an anti-bacterial cream. Seek immediate medical attention.

**Inhalation:**

If inhaled, remove to fresh air. If not breathing, give artificial respiration. If breathing is difficult, give oxygen. Get medical attention if symptoms appear.

**Serious Inhalation:**

Evacuate the victim to a safe area as soon as possible. Loosen tight clothing such as a collar, tie, belt or waistband. If breathing is difficult, administer oxygen. If the victim is not breathing, perform mouth-to-mouth resuscitation. Seek medical attention.

**Ingestion:**

Do NOT induce vomiting unless directed to do so by medical personnel. Never give anything by mouth to an unconscious person. If large quantities of this material are swallowed, call a physician immediately. Loosen tight clothing such as a collar, tie, belt or waistband.

**Serious Ingestion:** Not available.

## Section 5: Fire and Explosion Data

**Flammability of the Product:** Flammable.

**Auto-Ignition Temperature:** 497.78°C (928°F)

**Flash Points:** CLOSED CUP: -11.1°C (12°F). (Setaflash)

**Flammable Limits:** LOWER: 1.2% UPPER: 7.8%

**Products of Combustion:** These products are carbon oxides (CO, CO<sub>2</sub>).

**Fire Hazards in Presence of Various Substances:**

Highly flammable in presence of open flames and sparks, of heat. Slightly flammable to flammable in presence of oxidizing materials. Non-flammable in presence of shocks.

**Explosion Hazards in Presence of Various Substances:**

Risks of explosion of the product in presence of mechanical impact: Not available. Risks of explosion of the product in presence of static discharge: Not available. Explosive in presence of oxidizing materials, of acids.

**Fire Fighting Media and Instructions:**

Flammable liquid, soluble or dispersed in water. SMALL FIRE: Use DRY chemical powder. LARGE FIRE: Use alcohol foam, water spray or fog.

**Special Remarks on Fire Hazards:**

Extremely flammable liquid and vapor. Vapor may cause flash fire. Reacts on contact with iodine heptafluoride gas. Dioxygenyl tetrafluoroborate is as very powerful oxidant. The addition of a small particle to small samples of benzene, at ambient temperature, causes ignition. Contact with sodium peroxide with benzene causes ignition. Benzene ignites in contact with powdered chromic anhydride. Vigorous or incandescent reaction with hydrogen + Raney nickel (above 210 C) and bromine trifluoride.

**Special Remarks on Explosion Hazards:**

Benzene vapors + chlorine and light causes explosion. Reacts explosively with bromine pentafluoride, chlorine, chlorine trifluoride, diborane, nitric acid, nitryl perchlorate, liquid oxygen, ozone, silver perchlorate. Benzene + pentafluoride and methoxide (from arsenic pentafluoride and potassium methoxide) in trichlorotrifluoroethane causes explosion. Interaction

of nitryl perchlorate with benzene gave a slight explosion and flash. The solution of permanganic acid ( or its explosive anhydride, dimanganese heptoxide) produced by interaction of permanganates and sulfuric acid will explode on contact with benzene. Peroxodisulfuric acid is a very powerful oxidant. Uncontrolled contact with benzene may cause explosion. Mixtures of peroxomonsulfuric acid with benzene explodes.

## Section 6: Accidental Release Measures

**Small Spill:** Absorb with an inert material and put the spilled material in an appropriate waste disposal.

**Large Spill:**

Flammable liquid. Keep away from heat. Keep away from sources of ignition. Stop leak if without risk. Absorb with DRY earth, sand or other non-combustible material. Do not touch spilled material. Prevent entry into sewers, basements or confined areas; dike if needed. Be careful that the product is not present at a concentration level above TLV. Check TLV on the MSDS and with local authorities.

## Section 7: Handling and Storage

**Precautions:**

Keep locked up.. Keep away from heat. Keep away from sources of ignition. Ground all equipment containing material. Do not ingest. Do not breathe gas/fumes/ vapor/spray. In case of insufficient ventilation, wear suitable respiratory equipment. If ingested, seek medical advice immediately and show the container or the label. Avoid contact with skin and eyes. Keep away from incompatibles such as oxidizing agents, acids.

**Storage:**

Store in a segregated and approved area. Keep container in a cool, well-ventilated area. Keep container tightly closed and sealed until ready for use. Avoid all possible sources of ignition (spark or flame).

## Section 8: Exposure Controls/Personal Protection

**Engineering Controls:**

Provide exhaust ventilation or other engineering controls to keep the airborne concentrations of vapors below their respective threshold limit value. Ensure that eyewash stations and safety showers are proximal to the work-station location.

**Personal Protection:**

Splash goggles. Lab coat. Vapor respirator. Be sure to use an approved/certified respirator or equivalent. Gloves.

**Personal Protection in Case of a Large Spill:**

Splash goggles. Full suit. Vapor respirator. Boots. Gloves. A self contained breathing apparatus should be used to avoid inhalation of the product. Suggested protective clothing might not be sufficient; consult a specialist BEFORE handling this product.

**Exposure Limits:**

TWA: 0.5 STEL: 2.5 (ppm) from ACGIH (TLV) [United States] TWA: 1.6 STEL: 8 (mg/m<sup>3</sup>) from ACGIH (TLV) [United States] TWA: 0.1 STEL: 1 from NIOSH TWA: 1 STEL: 5 (ppm) from OSHA (PEL) [United States] TWA: 10 (ppm) from OSHA (PEL) [United States] TWA: 3 (ppm) [United Kingdom (UK)] TWA: 1.6 (mg/m<sup>3</sup>) [United Kingdom (UK)] TWA: 1 (ppm) [Canada] TWA: 3.2 (mg/m<sup>3</sup>) [Canada] TWA: 0.5 (ppm) [Canada] Consult local authorities for acceptable exposure limits.

## Section 9: Physical and Chemical Properties

**Physical state and appearance:** Liquid.

**Odor:**

Aromatic. Gasoline-like, rather pleasant. (Strong.)

**Taste:** Not available.

**Molecular Weight:** 78.11 g/mole

**Color:** Clear Colorless. Colorless to light yellow.

**pH (1% soln/water):** Not available.

**Boiling Point:** 80.1 (176.2°F)

**Melting Point:** 5.5°C (41.9°F)

**Critical Temperature:** 288.9°C (552°F)

**Specific Gravity:** 0.8787 @ 15 C (Water = 1)

**Vapor Pressure:** 10 kPa (@ 20°C)

**Vapor Density:** 2.8 (Air = 1)

**Volatility:** Not available.

**Odor Threshold:** 4.68 ppm

**Water/Oil Dist. Coeff.:** The product is more soluble in oil;  $\log(\text{oil/water}) = 2.1$

**Ionicity (in Water):** Not available.

**Dispersion Properties:** See solubility in water, diethyl ether, acetone.

**Solubility:**

Miscible in alcohol, chloroform, carbon disulfide oils, carbon tetrachloride, glacial acetic acid, diethyl ether, acetone. Very slightly soluble in cold water.

## Section 10: Stability and Reactivity Data

**Stability:** The product is stable.

**Instability Temperature:** Not available.

**Conditions of Instability:** Heat, ignition sources, incompatibles.

**Incompatibility with various substances:** Highly reactive with oxidizing agents, acids.

**Corrosivity:** Non-corrosive in presence of glass.

**Special Remarks on Reactivity:**

Benzene vapors + chlorine and light causes explosion. Reacts explosively with bromine pentafluoride, chlorine, chlorine trifluoride, diborane, nitric acid, nitryl perchlorate, liquid oxygen, ozone, silver perchlorate. Benzene + pentafluoride and methoxide (from arsenic pentafluoride and potassium methoxide) in trichlorotrifluoroethane causes explosion. Interaction of nitryl perchlorate with benzene gave a slight explosion and flash. The solution of permanganic acid ( or its explosive anhydride, dimanganese heptoxide) produced by interaction of permanganates and sulfuric acid will explode on contact with benzene. Peroxodisulfuric acid is a very powerful oxidant. Uncontrolled contact with benzene may cause explosion. Mixtures of peroxomonsulfuric acid with benzene explodes.

**Special Remarks on Corrosivity:** Not available.

**Polymerization:** Will not occur.

## Section 11: Toxicological Information

**Routes of Entry:** Absorbed through skin. Dermal contact. Eye contact. Inhalation.

**Toxicity to Animals:**

WARNING: THE LC50 VALUES HEREUNDER ARE ESTIMATED ON THE BASIS OF A 4-HOUR EXPOSURE. Acute oral toxicity (LD50): 930 mg/kg [Rat]. Acute dermal toxicity (LD50): >9400 mg/kg [Rabbit]. Acute toxicity of the vapor (LC50): 10000 7 hours [Rat].

**Chronic Effects on Humans:**

**CARCINOGENIC EFFECTS:** Classified A1 (Confirmed for human.) by ACGIH, 1 (Proven for human.) by IARC. **MUTAGENIC EFFECTS:** Classified POSSIBLE for human. Mutagenic for mammalian somatic cells. Mutagenic for bacteria and/or yeast. **DEVELOPMENTAL TOXICITY:** Classified Reproductive system/toxin/female [POSSIBLE]. Causes damage to the following organs: blood, bone marrow, central nervous system (CNS). May cause damage to the following organs: liver, Urinary System.

**Other Toxic Effects on Humans:**

Very hazardous in case of inhalation. Hazardous in case of skin contact (irritant, permeator), of ingestion.

**Special Remarks on Toxicity to Animals:** Not available.

**Special Remarks on Chronic Effects on Humans:**

May cause adverse reproductive effects (female fertility, Embryotoxic and/or foetotoxic in animal) and birth defects. May affect genetic material (mutagenic). May cause cancer (tumorigenic, leukemia) Human: passes the placental barrier, detected in maternal milk.

**Special Remarks on other Toxic Effects on Humans:**

Acute Potential Health Effects: Skin: Causes skin irritation. It can be absorbed through intact skin and affect the liver, blood, metabolism, and urinary system. Eyes: Causes eye irritation. Inhalation: Causes respiratory tract and mucous membrane irritation. Can be absorbed through the lungs. May affect behavior/Central and Peripheral nervous systems (somnolence, muscle weakness, general anesthetic, and other symptoms similar to ingestion), gastrointestinal tract (nausea), blood metabolism, urinary system. Ingestion: May be harmful if swallowed. May cause gastrointestinal tract irritation including vomiting. May affect behavior/Central and Peripheral nervous systems (convulsions, seizures, tremor, irritability, initial CNS stimulation followed by depression, loss of coordination, dizziness, headache, weakness, pallor, flushing), respiration (breathlessness and chest constriction), cardiovascular system, (shallow/rapid pulse), and blood.

## Section 12: Ecological Information

**Ecotoxicity:** Not available.

**BOD5 and COD:** Not available.

**Products of Biodegradation:**

Possibly hazardous short term degradation products are not likely. However, long term degradation products may arise.

**Toxicity of the Products of Biodegradation:** The products of degradation are less toxic than the product itself.

**Special Remarks on the Products of Biodegradation:** Not available.

## Section 13: Disposal Considerations

**Waste Disposal:**

Waste must be disposed of in accordance with federal, state and local environmental control regulations.

## Section 14: Transport Information

**DOT Classification:** CLASS 3: Flammable liquid.

**Identification:** : Benzene UNNA: 1114 PG: II

**Special Provisions for Transport:** Not available.

## Section 15: Other Regulatory Information

**Federal and State Regulations:**

California prop. 65: This product contains the following ingredients for which the State of California has found to cause cancer, birth defects or other reproductive harm, which would require a warning under the statute: Benzene California prop. 65 (no significant risk level): Benzene: 0.007 mg/day (value) California prop. 65: This product contains the following ingredients

for which the State of California has found to cause cancer which would require a warning under the statute: Benzene Connecticut carcinogen reporting list.: Benzene Connecticut hazardous material survey.: Benzene Illinois toxic substances disclosure to employee act: Benzene Illinois chemical safety act: Benzene New York release reporting list: Benzene Rhode Island RTK hazardous substances: Benzene Pennsylvania RTK: Benzene Minnesota: Benzene Michigan critical material: Benzene Massachusetts RTK: Benzene Massachusetts spill list: Benzene New Jersey: Benzene New Jersey spill list: Benzene Louisiana spill reporting: Benzene California Director's list of Hazardous Substances: Benzene TSCA 8(b) inventory: Benzene SARA 313 toxic chemical notification and release reporting: Benzene CERCLA: Hazardous substances.: Benzene: 10 lbs. (4.536 kg)

**Other Regulations:**

OSHA: Hazardous by definition of Hazard Communication Standard (29 CFR 1910.1200). EINECS: This product is on the European Inventory of Existing Commercial Chemical Substances.

**Other Classifications:**

**WHMIS (Canada):**

CLASS B-2: Flammable liquid with a flash point lower than 37.8°C (100°F). CLASS D-2A: Material causing other toxic effects (VERY TOXIC).

**DSCL (EEC):**

R11- Highly flammable. R22- Harmful if swallowed. R38- Irritating to skin. R41- Risk of serious damage to eyes. R45- May cause cancer. R62- Possible risk of impaired fertility. S2- Keep out of the reach of children. S26- In case of contact with eyes, rinse immediately with plenty of water and seek medical advice. S39- Wear eye/face protection. S46- If swallowed, seek medical advice immediately and show this container or label. S53- Avoid exposure - obtain special instructions before use.

**HMIS (U.S.A.):**

**Health Hazard:** 2

**Fire Hazard:** 3

**Reactivity:** 0

**Personal Protection:** h

**National Fire Protection Association (U.S.A.):**

**Health:** 2

**Flammability:** 3

**Reactivity:** 0

**Specific hazard:**

**Protective Equipment:**

Gloves. Lab coat. Vapor respirator. Be sure to use an approved/certified respirator or equivalent. Wear appropriate respirator when ventilation is inadequate. Splash goggles.

## Section 16: Other Information

**References:** Not available.

**Other Special Considerations:** Not available.

**Created:** 10/10/2005 08:35 PM

**Last Updated:** 11/06/2008 12:00 PM

*The information above is believed to be accurate and represents the best information currently available to us. However, we make no warranty of merchantability or any other warranty, express or implied, with respect to such information, and we assume no liability resulting from its use. Users should make their own investigations to determine the suitability of the information for their particular purposes. In no event shall ScienceLab.com be liable for any claims, losses, or damages of any third party or for lost profits or any special, indirect, incidental, consequential or exemplary damages, howsoever arising, even if ScienceLab.com has been advised of the possibility of such damages.*



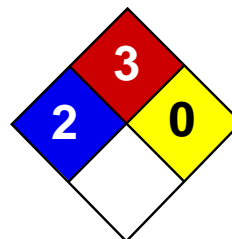

Health	2
Fire	3
Reactivity	0
Personal Protection	H

## Material Safety Data Sheet Toluene MSDS

### Section 1: Chemical Product and Company Identification

**Product Name:** Toluene

**Catalog Codes:** SLT2857, SLT3277

**CAS#:** 108-88-3

**RTECS:** XS5250000

**TSCA:** TSCA 8(b) inventory: Toluene

**CI#:** Not available.

**Synonym:** Toluol, Tolu-Sol; Methylbenzene; Methacide; Phenylmethane; Methylbenzol

**Chemical Name:** Toluene

**Chemical Formula:** C<sub>6</sub>H<sub>5</sub>-CH<sub>3</sub> or C<sub>7</sub>H<sub>8</sub>

**Contact Information:**

**Sciencelab.com, Inc.**

14025 Smith Rd.

Houston, Texas 77396

US Sales: **1-800-901-7247**

International Sales: **1-281-441-4400**

Order Online: [ScienceLab.com](http://ScienceLab.com)

**CHEMTREC (24HR Emergency Telephone), call:**

1-800-424-9300

**International CHEMTREC, call:** 1-703-527-3887

**For non-emergency assistance, call:** 1-281-441-4400

### Section 2: Composition and Information on Ingredients

**Composition:**

Name	CAS #	% by Weight
Toluene	108-88-3	100

**Toxicological Data on Ingredients:** Toluene: ORAL (LD50): Acute: 636 mg/kg [Rat]. DERMAL (LD50): Acute: 14100 mg/kg [Rabbit]. VAPOR (LC50): Acute: 49000 mg/m 4 hours [Rat]. 440 ppm 24 hours [Mouse].

### Section 3: Hazards Identification

**Potential Acute Health Effects:**

Hazardous in case of skin contact (irritant), of eye contact (irritant), of ingestion, of inhalation. Slightly hazardous in case of skin contact (permeator).

**Potential Chronic Health Effects:**

CARCINOGENIC EFFECTS: A4 (Not classifiable for human or animal.) by ACGIH, 3 (Not classifiable for human.) by IARC. MUTAGENIC EFFECTS: Not available. TERATOGENIC EFFECTS: Not available. DEVELOPMENTAL TOXICITY: Not available. The substance may be toxic to blood, kidneys, the nervous system, liver, brain, central nervous system (CNS). Repeated or prolonged exposure to the substance can produce target organs damage.

### Section 4: First Aid Measures

**Eye Contact:**

Check for and remove any contact lenses. In case of contact, immediately flush eyes with plenty of water for at least 15 minutes. Get medical attention.

**Skin Contact:**

In case of contact, immediately flush skin with plenty of water. Cover the irritated skin with an emollient. Remove contaminated clothing and shoes. Wash clothing before reuse. Thoroughly clean shoes before reuse. Get medical attention.

**Serious Skin Contact:**

Wash with a disinfectant soap and cover the contaminated skin with an anti-bacterial cream. Seek immediate medical attention.

**Inhalation:**

If inhaled, remove to fresh air. If not breathing, give artificial respiration. If breathing is difficult, give oxygen. Get medical attention.

**Serious Inhalation:**

Evacuate the victim to a safe area as soon as possible. Loosen tight clothing such as a collar, tie, belt or waistband. If breathing is difficult, administer oxygen. If the victim is not breathing, perform mouth-to-mouth resuscitation. **WARNING:** It may be hazardous to the person providing aid to give mouth-to-mouth resuscitation when the inhaled material is toxic, infectious or corrosive. Seek medical attention.

**Ingestion:**

Do NOT induce vomiting unless directed to do so by medical personnel. Never give anything by mouth to an unconscious person. If large quantities of this material are swallowed, call a physician immediately. Loosen tight clothing such as a collar, tie, belt or waistband.

**Serious Ingestion:** Not available.

## Section 5: Fire and Explosion Data

**Flammability of the Product:** Flammable.

**Auto-Ignition Temperature:** 480°C (896°F)

**Flash Points:** CLOSED CUP: 4.4444°C (40°F). (Setaflash) OPEN CUP: 16°C (60.8°F).

**Flammable Limits:** LOWER: 1.1% UPPER: 7.1%

**Products of Combustion:** These products are carbon oxides (CO, CO<sub>2</sub>).

**Fire Hazards in Presence of Various Substances:**

Flammable in presence of open flames and sparks, of heat. Non-flammable in presence of shocks.

**Explosion Hazards in Presence of Various Substances:**

Risks of explosion of the product in presence of mechanical impact: Not available. Risks of explosion of the product in presence of static discharge: Not available.

**Fire Fighting Media and Instructions:**

Flammable liquid, insoluble in water. SMALL FIRE: Use DRY chemical powder. LARGE FIRE: Use water spray or fog.

**Special Remarks on Fire Hazards:** Not available.

**Special Remarks on Explosion Hazards:**

Toluene forms explosive reaction with 1,3-dichloro-5,5-dimethyl-2,4-imidazolididione; dinitrogen tetroxide; concentrated nitric acid, sulfuric acid + nitric acid; N<sub>2</sub>O<sub>4</sub>; AgClO<sub>4</sub>; BrF<sub>3</sub>; Uranium hexafluoride; sulfur dichloride. Also forms an explosive mixture with tetranitromethane.

## Section 6: Accidental Release Measures

**Small Spill:** Absorb with an inert material and put the spilled material in an appropriate waste disposal.

**Large Spill:**

Toxic flammable liquid, insoluble or very slightly soluble in water. Keep away from heat. Keep away from sources of ignition. Stop leak if without risk. Absorb with DRY earth, sand or other non-combustible material. Do not get water inside container. Do not touch spilled material. Prevent entry into sewers, basements or confined areas; dike if needed. Call for assistance on disposal. Be careful that the product is not present at a concentration level above TLV. Check TLV on the MSDS and with local authorities.

**Section 7: Handling and Storage****Precautions:**

Keep away from heat. Keep away from sources of ignition. Ground all equipment containing material. Do not ingest. Do not breathe gas/fumes/ vapor/spray. Wear suitable protective clothing. In case of insufficient ventilation, wear suitable respiratory equipment. If ingested, seek medical advice immediately and show the container or the label. Avoid contact with skin and eyes. Keep away from incompatibles such as oxidizing agents.

**Storage:**

Store in a segregated and approved area. Keep container in a cool, well-ventilated area. Keep container tightly closed and sealed until ready for use. Avoid all possible sources of ignition (spark or flame).

**Section 8: Exposure Controls/Personal Protection****Engineering Controls:**

Provide exhaust ventilation or other engineering controls to keep the airborne concentrations of vapors below their respective threshold limit value. Ensure that eyewash stations and safety showers are proximal to the work-station location.

**Personal Protection:**

Splash goggles. Lab coat. Vapor respirator. Be sure to use an approved/certified respirator or equivalent. Gloves.

**Personal Protection in Case of a Large Spill:**

Splash goggles. Full suit. Vapor respirator. Boots. Gloves. A self contained breathing apparatus should be used to avoid inhalation of the product. Suggested protective clothing might not be sufficient; consult a specialist BEFORE handling this product.

**Exposure Limits:**

TWA: 200 STEL: 500 CEIL: 300 (ppm) from OSHA (PEL) [United States] TWA: 50 (ppm) from ACGIH (TLV) [United States] SKIN TWA: 100 STEL: 150 from NIOSH [United States] TWA: 375 STEL: 560 (mg/m<sup>3</sup>) from NIOSH [United States] Consult local authorities for acceptable exposure limits.

**Section 9: Physical and Chemical Properties**

**Physical state and appearance:** Liquid.

**Odor:** Sweet, pungent, Benzene-like.

**Taste:** Not available.

**Molecular Weight:** 92.14 g/mole

**Color:** Colorless.

**pH (1% soln/water):** Not applicable.

**Boiling Point:** 110.6°C (231.1°F)

**Melting Point:** -95°C (-139°F)

**Critical Temperature:** 318.6°C (605.5°F)

**Specific Gravity:** 0.8636 (Water = 1)

**Vapor Pressure:** 3.8 kPa (@ 25°C)

**Vapor Density:** 3.1 (Air = 1)

**Volatility:** Not available.

**Odor Threshold:** 1.6 ppm

**Water/Oil Dist. Coeff.:** The product is more soluble in oil;  $\log(\text{oil/water}) = 2.7$

**Ionicity (in Water):** Not available.

**Dispersion Properties:** See solubility in water, diethyl ether, acetone.

**Solubility:**

Soluble in diethyl ether, acetone. Practically insoluble in cold water. Soluble in ethanol, benzene, chloroform, glacial acetic acid, carbon disulfide. Solubility in water: 0.561 g/l @ 25 deg. C.

## Section 10: Stability and Reactivity Data

**Stability:** The product is stable.

**Instability Temperature:** Not available.

**Conditions of Instability:** Heat, ignition sources (flames, sparks, static), incompatible materials

**Incompatibility with various substances:** Reactive with oxidizing agents.

**Corrosivity:** Non-corrosive in presence of glass.

**Special Remarks on Reactivity:**

Incompatible with strong oxidizers, silver perchlorate, sodium difluoride, Tetranitromethane, Uranium Hexafluoride. Frozen Bromine Trifluoride reacts violently with Toluene at -80 deg. C. Reacts chemically with nitrogen oxides, or halogens to form nitrotoluene, nitrobenzene, and nitrophenol and halogenated products, respectively.

**Special Remarks on Corrosivity:** Not available.

**Polymerization:** Will not occur.

## Section 11: Toxicological Information

**Routes of Entry:** Absorbed through skin. Dermal contact. Eye contact. Inhalation. Ingestion.

**Toxicity to Animals:**

WARNING: THE LC50 VALUES HEREUNDER ARE ESTIMATED ON THE BASIS OF A 4-HOUR EXPOSURE. Acute oral toxicity (LD50): 636 mg/kg [Rat]. Acute dermal toxicity (LD50): 14100 mg/kg [Rabbit]. Acute toxicity of the vapor (LC50): 440 24 hours [Mouse].

**Chronic Effects on Humans:**

CARCINOGENIC EFFECTS: A4 (Not classifiable for human or animal.) by ACGIH, 3 (Not classifiable for human.) by IARC. May cause damage to the following organs: blood, kidneys, the nervous system, liver, brain, central nervous system (CNS).

**Other Toxic Effects on Humans:**

Hazardous in case of skin contact (irritant), of ingestion, of inhalation. Slightly hazardous in case of skin contact (permeator).

**Special Remarks on Toxicity to Animals:**

Lowest Published Lethal Dose: LDL [Human] - Route: Oral; Dose: 50 mg/kg LCL [Rabbit] - Route: Inhalation; Dose: 55000 ppm/40min

**Special Remarks on Chronic Effects on Humans:**

Detected in maternal milk in human. Passes through the placental barrier in human. Embryotoxic and/or foetotoxic in animal. May cause adverse reproductive effects and birth defects (teratogenic). May affect genetic material (mutagenic)

**Special Remarks on other Toxic Effects on Humans:**

Acute Potential Health Effects: Skin: Causes mild to moderate skin irritation. It can be absorbed to some extent through the skin. Eyes: Causes mild to moderate eye irritation with a burning sensation. Splash contact with eyes also causes conjunctivitis, blepharospasm, corneal edema, corneal abrasions. This usually resolves in 2 days. Inhalation: Inhalation of vapor may cause respiratory tract irritation causing coughing and wheezing, and nasal discharge. Inhalation of high concentrations may affect behavior and cause central nervous system effects characterized by nausea, headache, dizziness, tremors, restlessness, lightheadedness, exhilaration, memory loss, insomnia, impaired reaction time, drowsiness, ataxia, hallucinations, somnolence, muscle contraction or spasticity, unconsciousness and coma. Inhalation of high concentration of vapor may also affect the cardiovascular system (rapid heart beat, heart palpitations, increased or decreased blood pressure, dysrhythmia, ), respiration (acute pulmonary edema, respiratory depression, apnea, asphyxia), cause vision disturbances and dilated pupils, and cause loss of appetite. Ingestion: Aspiration hazard. Aspiration of Toluene into the lungs may cause chemical pneumonitis. May cause irritation of the digestive tract with nausea, vomiting, pain. May have effects similar to that of acute inhalation. Chronic Potential Health Effects: Inhalation and Ingestion: Prolonged or repeated exposure via inhalation may cause central nervous system and cardiovascular symptoms similar to that of acute inhalation and ingestion as well liver damage/failure, kidney damage/failure (with hematuria, proteinuria, oliguria, renal tubular acidosis), brain damage, weight loss, blood (pigmented or nucleated red blood cells, changes in white blood cell count), bone marrow changes, electrolyte imbalances (Hypokalemia, Hypophosphatemia), severe, muscle weakness and Rhabdomyolysis. Skin: Repeated or prolonged skin contact may cause defatting dermatitis.

## Section 12: Ecological Information

### Ecotoxicity:

Ecotoxicity in water (LC50): 313 mg/l 48 hours [Daphnia (daphnia)]. 17 mg/l 24 hours [Fish (Blue Gill)]. 13 mg/l 96 hours [Fish (Blue Gill)]. 56 mg/l 24 hours [Fish (Fathead minnow)]. 34 mg/l 96 hours [Fish (Fathead minnow)]. 56.8 ppm any hours [Fish (Goldfish)].

**BOD5 and COD:** Not available.

### Products of Biodegradation:

Possibly hazardous short term degradation products are not likely. However, long term degradation products may arise.

**Toxicity of the Products of Biodegradation:** The products of degradation are less toxic than the product itself.

**Special Remarks on the Products of Biodegradation:** Not available.

## Section 13: Disposal Considerations

### Waste Disposal:

Waste must be disposed of in accordance with federal, state and local environmental control regulations.

## Section 14: Transport Information

**DOT Classification:** CLASS 3: Flammable liquid.

**Identification:** : Toluene UNNA: 1294 PG: II

**Special Provisions for Transport:** Not available.

## Section 15: Other Regulatory Information

### Federal and State Regulations:

California prop. 65: This product contains the following ingredients for which the State of California has found to cause cancer, birth defects or other reproductive harm, which would require a warning under the statute: Toluene California prop. 65 (no significant risk level): Toluene: 7 mg/day (value) California prop. 65 (acceptable daily intake level): Toluene: 7 mg/day (value) California prop. 65: This product contains the following ingredients for which the State of California has found to cause birth defects which would require a warning under the statute: Toluene Connecticut hazardous material survey.: Toluene Illinois

toxic substances disclosure to employee act: Toluene Illinois chemical safety act: Toluene New York release reporting list: Toluene Rhode Island RTK hazardous substances: Toluene Pennsylvania RTK: Toluene Florida: Toluene Minnesota: Toluene Michigan critical material: Toluene Massachusetts RTK: Toluene Massachusetts spill list: Toluene New Jersey: Toluene New Jersey spill list: Toluene Louisiana spill reporting: Toluene California Director's List of Hazardous Substances.: Toluene TSCA 8(b) inventory: Toluene TSCA 8(d) H and S data reporting: Toluene: Effective date: 10/04/82; Sunset Date: 10/0/92 SARA 313 toxic chemical notification and release reporting: Toluene CERCLA: Hazardous substances.: Toluene: 1000 lbs. (453.6 kg)

**Other Regulations:**

OSHA: Hazardous by definition of Hazard Communication Standard (29 CFR 1910.1200). EINECS: This product is on the European Inventory of Existing Commercial Chemical Substances.

**Other Classifications:**

**WHMIS (Canada):**

CLASS B-2: Flammable liquid with a flash point lower than 37.8°C (100°F). CLASS D-2A: Material causing other toxic effects (VERY TOXIC).

**DSCL (EEC):**

R11- Highly flammable. R20- Harmful by inhalation. S16- Keep away from sources of ignition - No smoking. S25- Avoid contact with eyes. S29- Do not empty into drains. S33- Take precautionary measures against static discharges.

**HMS (U.S.A.):**

**Health Hazard:** 2

**Fire Hazard:** 3

**Reactivity:** 0

**Personal Protection:** h

**National Fire Protection Association (U.S.A.):**

**Health:** 2

**Flammability:** 3

**Reactivity:** 0

**Specific hazard:**

**Protective Equipment:**

Gloves. Lab coat. Vapor respirator. Be sure to use an approved/certified respirator or equivalent. Wear appropriate respirator when ventilation is inadequate. Splash goggles.

## Section 16: Other Information

**References:** Not available.

**Other Special Considerations:** Not available.

**Created:** 10/10/2005 08:30 PM

**Last Updated:** 11/06/2008 12:00 PM

*The information above is believed to be accurate and represents the best information currently available to us. However, we make no warranty of merchantability or any other warranty, express or implied, with respect to such information, and we assume no liability resulting from its use. Users should make their own investigations to determine the suitability of the information for their particular purposes. In no event shall ScienceLab.com be liable for any claims, losses, or damages of any third party or for lost profits or any special, indirect, incidental, consequential or exemplary damages, howsoever arising, even if ScienceLab.com has been advised of the possibility of such damages.*

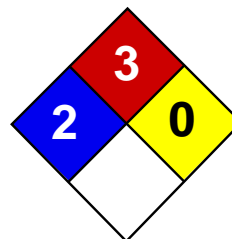

Health	2
Fire	3
Reactivity	0
Personal Protection	H

## Material Safety Data Sheet Ethylbenzene MSDS

### Section 1: Chemical Product and Company Identification

**Product Name:** Ethylbenzene

**Catalog Codes:** SLE2044

**CAS#:** 100-41-4

**RTECS:** DA0700000

**TSCA:** TSCA 8(b) inventory: Ethylbenzene

**CI#:** Not available.

**Synonym:** Ethyl Benzene; Ethylbenzol; Phenylethane

**Chemical Name:** Ethylbenzene

**Chemical Formula:** C<sub>8</sub>H<sub>10</sub>

**Contact Information:**

**Sciencelab.com, Inc.**

14025 Smith Rd.

Houston, Texas 77396

US Sales: **1-800-901-7247**

International Sales: **1-281-441-4400**

Order Online: [ScienceLab.com](http://ScienceLab.com)

**CHEMTREC (24HR Emergency Telephone), call:**

1-800-424-9300

**International CHEMTREC, call:** 1-703-527-3887

**For non-emergency assistance, call:** 1-281-441-4400

### Section 2: Composition and Information on Ingredients

**Composition:**

Name	CAS #	% by Weight
Ethylbenzene	100-41-4	100

**Toxicological Data on Ingredients:** Ethylbenzene: ORAL (LD50): Acute: 3500 mg/kg [Rat].

### Section 3: Hazards Identification

**Potential Acute Health Effects:**

Hazardous in case of eye contact (irritant), of ingestion, of inhalation. Slightly hazardous in case of skin contact (irritant, permeator).

**Potential Chronic Health Effects:**

Slightly hazardous in case of skin contact (irritant, sensitizer). **CARCINOGENIC EFFECTS:** Classified 2B (Possible for human.) by IARC. **MUTAGENIC EFFECTS:** Mutagenic for mammalian somatic cells. Mutagenic for bacteria and/or yeast. **TERATOGENIC EFFECTS:** Not available. **DEVELOPMENTAL TOXICITY:** Not available. The substance may be toxic to central nervous system (CNS). Repeated or prolonged exposure to the substance can produce target organs damage.

### Section 4: First Aid Measures

**Eye Contact:**

Check for and remove any contact lenses. In case of contact, immediately flush eyes with plenty of water for at least 15 minutes. Cold water may be used. WARM water MUST be used. Get medical attention.

**Skin Contact:** Wash with soap and water. Cover the irritated skin with an emollient. Get medical attention if irritation develops.

**Serious Skin Contact:** Not available.

**Inhalation:**

If inhaled, remove to fresh air. If not breathing, give artificial respiration. If breathing is difficult, give oxygen. Get medical attention.

**Serious Inhalation:**

Evacuate the victim to a safe area as soon as possible. Loosen tight clothing such as a collar, tie, belt or waistband. If breathing is difficult, administer oxygen. If the victim is not breathing, perform mouth-to-mouth resuscitation. WARNING: It may be hazardous to the person providing aid to give mouth-to-mouth resuscitation when the inhaled material is toxic, infectious or corrosive. Seek medical attention.

**Ingestion:**

Do NOT induce vomiting unless directed to do so by medical personnel. Never give anything by mouth to an unconscious person. Loosen tight clothing such as a collar, tie, belt or waistband. Get medical attention if symptoms appear.

**Serious Ingestion:** Not available.

## Section 5: Fire and Explosion Data

**Flammability of the Product:** Flammable.

**Auto-Ignition Temperature:** 432°C (809.6°F)

**Flash Points:**

CLOSED CUP: 15°C (59°F). (Tagliabue.) OPEN CUP: 26.667°C (80°F) (Cleveland) (CHRIS, 2001) CLOSED CUP: 12.8 C (55 F) (Bingham et al, 2001; NIOSH, 2001) CLOSED CUP: 21 C (70 F) (NFPA)

**Flammable Limits:** LOWER: 0.8% - 1.6%UPPER: 6.7% - 7%

**Products of Combustion:** These products are carbon oxides (CO, CO<sub>2</sub>).

**Fire Hazards in Presence of Various Substances:** Highly flammable in presence of open flames and sparks, of heat.

**Explosion Hazards in Presence of Various Substances:**

Risks of explosion of the product in presence of mechanical impact: Not available. Risks of explosion of the product in presence of static discharge: Not available. Slightly explosive in presence of heat.

**Fire Fighting Media and Instructions:**

Flammable liquid, soluble or dispersed in water. SMALL FIRE: Use DRY chemical powder. LARGE FIRE: Use alcohol foam, water spray or fog.

**Special Remarks on Fire Hazards:**

Vapor may travel considerable distance to source of ignition and flash back. Vapors may form explosive mixtures with air. When heated to decomposition it emits acrid smoke and irritating fumes.

**Special Remarks on Explosion Hazards:** Vapors may form explosive mixtures in air.

## Section 6: Accidental Release Measures

**Small Spill:** Absorb with an inert material and put the spilled material in an appropriate waste disposal.

**Large Spill:**

Flammable liquid. Keep away from heat. Keep away from sources of ignition. Stop leak if without risk. Absorb with DRY earth, sand or other non-combustible material. Do not touch spilled material. Prevent entry into sewers, basements or confined areas; dike if needed. Be careful that the product is not present at a concentration level above TLV. Check TLV on the MSDS and with local authorities.



## Section 7: Handling and Storage

### Precautions:

Keep away from heat. Keep away from sources of ignition. Ground all equipment containing material. Do not ingest. Do not breathe gas/fumes/ vapor/spray. Avoid contact with eyes. Wear suitable protective clothing. In case of insufficient ventilation, wear suitable respiratory equipment. If ingested, seek medical advice immediately and show the container or the label. Keep away from incompatibles such as oxidizing agents.

### Storage:

Store in a segregated and approved area. Keep container in a cool, well-ventilated area. Keep container tightly closed and sealed until ready for use. Avoid all possible sources of ignition (spark or flame). Sensitive to light. Store in light-resistant containers.

## Section 8: Exposure Controls/Personal Protection

### Engineering Controls:

Provide exhaust ventilation or other engineering controls to keep the airborne concentrations of vapors below their respective threshold limit value. Ensure that eyewash stations and safety showers are proximal to the work-station location.

### Personal Protection:

Splash goggles. Lab coat. Vapor respirator. Be sure to use an approved/certified respirator or equivalent. Gloves.

### Personal Protection in Case of a Large Spill:

Splash goggles. Full suit. Vapor respirator. Boots. Gloves. A self contained breathing apparatus should be used to avoid inhalation of the product. Suggested protective clothing might not be sufficient; consult a specialist BEFORE handling this product.

### Exposure Limits:

TWA: 100 STEL: 125 (ppm) from OSHA (PEL) [United States] TWA: 435 STEL: 545 from OSHA (PEL) [United States] TWA: 435 STEL: 545 (mg/m<sup>3</sup>) from NIOSH [United States] TWA: 100 STEL: 125 (ppm) from NIOSH [United States] TWA: 100 STEL: 125 (ppm) from ACGIH (TLV) [United States] TWA: 100 STEL: 125 (ppm) [United Kingdom (UK)] TWA: 100 STEL: 125 (ppm) [Belgium] TWA: 100 STEL: 125 (ppm) [Finland] TWA: 50 (ppm) [Norway] Consult local authorities for acceptable exposure limits.

## Section 9: Physical and Chemical Properties

**Physical state and appearance:** Liquid.

**Odor:** Sweetish. Gasoline-like. Aromatic.

**Taste:** Not available.

**Molecular Weight:** 106.16 g/mole

**Color:** Colorless.

**pH (1% soln/water):** Not available.

**Boiling Point:** 136°C (276.8°F)

**Melting Point:** -94.9 (-138.8°F)

**Critical Temperature:** 617.15°C (1142.9°F)

**Specific Gravity:** 0.867 (Water = 1)

**Vapor Pressure:** 0.9 kPa (@ 20°C)

**Vapor Density:** 3.66 (Air = 1)

**Volatility:** 100% (v/v).

**Odor Threshold:** 140 ppm

**Water/Oil Dist. Coeff.:** The product is more soluble in oil;  $\log(\text{oil/water}) = 3.1$

**Ionicity (in Water):** Not available.

**Dispersion Properties:** See solubility in water, diethyl ether.

**Solubility:**

Easily soluble in diethyl ether. Very slightly soluble in cold water or practically insoluble in water. Soluble in all proportions in Ethyl alcohol. Soluble in Carbon tetrachloride, Benzene. Insoluble in Ammonia. Slightly soluble in Chloroform. Solubility in Water: 169 mg/l @ 25 deg. C.; 0.014 g/100 ml @ 15 deg. C.

## Section 10: Stability and Reactivity Data

**Stability:** The product is stable.

**Instability Temperature:** Not available.

**Conditions of Instability:** Heat, ignition sources (flames, sparks, static), incompatible materials, light

**Incompatibility with various substances:** Reactive with oxidizing agents.

**Corrosivity:** Not considered to be corrosive for metals and glass.

**Special Remarks on Reactivity:**

Can react vigorously with oxidizing materials. Sensitive to light.

**Special Remarks on Corrosivity:** Not available.

**Polymerization:** Will not occur.

## Section 11: Toxicological Information

**Routes of Entry:** Absorbed through skin. Inhalation.

**Toxicity to Animals:** Acute oral toxicity (LD50): 3500 mg/kg [Rat].

**Chronic Effects on Humans:**

CARCINOGENIC EFFECTS: Classified 2B (Possible for human.) by IARC. MUTAGENIC EFFECTS: Mutagenic for mammalian somatic cells. Mutagenic for bacteria and/or yeast. May cause damage to the following organs: central nervous system (CNS).

**Other Toxic Effects on Humans:**

Hazardous in case of ingestion, of inhalation. Slightly hazardous in case of skin contact (irritant, permeator).

**Special Remarks on Toxicity to Animals:**

Lethal Dose/Conc 50% Kill: LD50 [Rabbit] - Route: Skin; Dose: 17800 ul/kg Lowest Published Lethal Dose/Conc: LDL[Rat] - Route: Inhalation (vapor); Dose: 4000 ppm/4 H

**Special Remarks on Chronic Effects on Humans:**

May cause adverse reproductive effects and birth defects (teratogenic) based on animal test data. May cause cancer based on animals data. IARC evidence for carcinogenicity in animals is sufficient. IARC evidence of carcinogenicity in humans inadequate. May affect genetic material (mutagenic).

**Special Remarks on other Toxic Effects on Humans:**

Acute Potential Health Effects: Skin: Can cause mild skin irritation. It can be absorbed through intact skin. Eyes: Contact with vapor or liquid can cause severe eye irritation depending on concentration. It may also cause conjunctivitis. At a vapor exposure level of 85 - 200 ppm, it is mildly and transiently irritating to the eyes; 1000 ppm causes further irritation and tearing; 2000 ppm results in immediate and severe irritation and tearing; 5,000 ppm is intolerable (ACGIH, 1991; Clayton and Clayton, 1994). Standard draize test for eye irritation using 500 mg resulted in severe irritation (RTECS) Inhalation: Exposure to high concentrations can cause nasal, mucous membrane and respiratory tract irritation and can also result in chest constriction and, trouble breathing, respiratory failure, and even death. It can also affect behavior/Central Nervous System. The effective dose for CNS depression in experimental animals was 10,000 ppm (ACGIH, 1991). Symptoms of CNS depression include

headache, nausea, weakness, dizziness, vertigo, irritability, fatigue, lightheadedness, sleepiness, tremor, loss of coordination, judgement and consciousness, coma, and death. It can also cause pulmonary edema. Inhalation of 85 ppm can produce fatigue, insomnia, headache, and mild irritation of the respiratory tract (Haley & Berndt, 1987). Ingestion: Do not drink, pipet or siphon by mouth. May cause gastrointestinal/digestive tract irritation with Abdominal pain, nausea, vomiting. Ethylbenzene is a pulmonary aspiration hazard. Pulmonary aspiration of even small amounts of the liquid may cause fatal pneumonitis. It may also affect behavior/central nervous system with

## Section 12: Ecological Information

### Ecotoxicity:

Ecotoxicity in water (LC50): 14 mg/l 96 hours [Fish (Trout)] (static). 12.1 mg/l 96 hours [Fish (Fathead Minnow)] (flow-through)]. 150 mg/l 96 hours [Fish (Blue Gill/Sunfish)] (static). 275 mg/l 96 hours [Fish (Sheepshead Minnow)]. 42.3 mg/l 96 hours [Fish (Fathead Minnow)](soft water). 87.6mg/l 96 hours [Shrimp].

**BOD5 and COD:** Not available.

### Products of Biodegradation:

Possibly hazardous short term degradation products are not likely. However, long term degradation products may arise.

**Toxicity of the Products of Biodegradation:** The products of degradation are less toxic than the product itself.

**Special Remarks on the Products of Biodegradation:** Not available.

## Section 13: Disposal Considerations

### Waste Disposal:

Waste must be disposed of in accordance with federal, state and local environmental control regulations.

## Section 14: Transport Information

**DOT Classification:** CLASS 3: Flammable liquid.

**Identification:** : Ethylbenzene UNNA: 1175 PG: II

**Special Provisions for Transport:** Not available.

## Section 15: Other Regulatory Information

### Federal and State Regulations:

Connecticut hazardous material survey.: Ethylbenzene Illinois toxic substances disclosure to employee act: Ethylbenzene Illinois chemical safety act: Ethylbenzene New York release reporting list: Ethylbenzene Rhode Island RTK hazardous substances: Ethylbenzene Pennsylvania RTK: Ethylbenzene Minnesota: Ethylbenzene Massachusetts RTK: Ethylbenzene Massachusetts spill list: Ethylbenzene New Jersey: Ethylbenzene New Jersey spill list: Ethylbenzene Louisiana spill reporting: Ethylbenzene California Director's List of Hazardous Substances: Ethylbenzene TSCA 8(b) inventory: Ethylbenzene TSCA 4(a) proposed test rules: Ethylbenzene TSCA 8(d) H and S data reporting: Ethylbenzene: Effective Date: 6/19/87; Sunset Date: 6/19/97 SARA 313 toxic chemical notification and release reporting: Ethylbenzene

### Other Regulations:

OSHA: Hazardous by definition of Hazard Communication Standard (29 CFR 1910.1200). EINECS: This product is on the European Inventory of Existing Commercial Chemical Substances.

### Other Classifications:

### WHMIS (Canada):

CLASS B-2: Flammable liquid with a flash point lower than 37.8°C (100°F). CLASS D-2A: Material causing other toxic effects (VERY TOXIC). CLASSE D-2B: Material causing other toxic effects (TOXIC).

**DSCL (EEC):**

R11- Highly flammable. R20- Harmful by inhalation. S16- Keep away from sources of ignition - No smoking. S24/25- Avoid contact with skin and eyes. S29- Do not empty into drains.

**HMIS (U.S.A.):**

**Health Hazard:** 2

**Fire Hazard:** 3

**Reactivity:** 0

**Personal Protection:** h

**National Fire Protection Association (U.S.A.):**

**Health:** 2

**Flammability:** 3

**Reactivity:** 0

**Specific hazard:**

**Protective Equipment:**

Gloves. Lab coat. Vapor respirator. Be sure to use an approved/certified respirator or equivalent. Wear appropriate respirator when ventilation is inadequate. Splash goggles.

**Section 16: Other Information****References:**

-Manufacturer's Material Safety Data Sheet. -Fire Protection Guide to Hazardous Materials, 13th ed., National Fire Protection Association (NFPA) -Registry of Toxic Effects of Chemical Substances (RTECS) -Chemical Hazard Response Information System (CHRIS) -Hazardous Substance Data Bank (HSDB) -New Jersey Hazardous Substance Fact Sheet -Ariel Global View -Reprotext System

**Other Special Considerations:** Not available.

**Created:** 10/09/2005 05:28 PM

**Last Updated:** 11/06/2008 12:00 PM

*The information above is believed to be accurate and represents the best information currently available to us. However, we make no warranty of merchantability or any other warranty, express or implied, with respect to such information, and we assume no liability resulting from its use. Users should make their own investigations to determine the suitability of the information for their particular purposes. In no event shall ScienceLab.com be liable for any claims, losses, or damages of any third party or for lost profits or any special, indirect, incidental, consequential or exemplary damages, howsoever arising, even if ScienceLab.com has been advised of the possibility of such damages.*

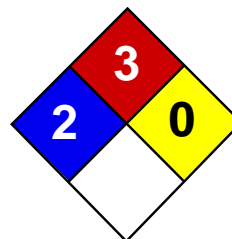

Health	2
Fire	3
Reactivity	0
Personal Protection	H

## Material Safety Data Sheet

### Xylenes MSDS

#### Section 1: Chemical Product and Company Identification

**Product Name:** Xylenes

**Catalog Codes:** SLX1075, SLX1129, SLX1042, SLX1096

**CAS#:** 1330-20-7

**RTECS:** ZE2100000

**TSCA:** TSCA 8(b) inventory: Xylenes

**CI#:** Not available.

**Synonym:** Xylenes; Dimethylbenzene; xylol; methyltoluene

**Chemical Name:** Xylenes (o-, m-, p- isomers)

**Chemical Formula:** C<sub>6</sub>H<sub>4</sub>(CH<sub>3</sub>)<sub>2</sub>

**Contact Information:**

**Sciencelab.com, Inc.**

14025 Smith Rd.

Houston, Texas 77396

US Sales: **1-800-901-7247**

International Sales: **1-281-441-4400**

Order Online: [ScienceLab.com](http://ScienceLab.com)

**CHEMTREC (24HR Emergency Telephone), call:**

1-800-424-9300

**International CHEMTREC, call:** 1-703-527-3887

**For non-emergency assistance, call:** 1-281-441-4400

#### Section 2: Composition and Information on Ingredients

**Composition:**

Name	CAS #	% by Weight
Xylenes	1330-20-7	100

**Toxicological Data on Ingredients:** Xylenes: ORAL (LD50): Acute: 4300 mg/kg [Rat]. 2119 mg/kg [Mouse]. DERMAL (LD50): Acute: >1700 mg/kg [Rabbit].

#### Section 3: Hazards Identification

**Potential Acute Health Effects:** Hazardous in case of skin contact (irritant, permeator), of eye contact (irritant), of ingestion, of inhalation.

**Potential Chronic Health Effects:**

CARCINOGENIC EFFECTS: 3 (Not classifiable for human.) by IARC. MUTAGENIC EFFECTS: Not available. TERATOGENIC EFFECTS: Not available. DEVELOPMENTAL TOXICITY: Not available. The substance may be toxic to blood, kidneys, liver, mucous membranes, bone marrow, central nervous system (CNS). Repeated or prolonged exposure to the substance can produce target organs damage.

#### Section 4: First Aid Measures

**Eye Contact:**

Check for and remove any contact lenses. In case of contact, immediately flush eyes with plenty of water for at least 15 minutes. Get medical attention.

**Skin Contact:**

In case of contact, immediately flush skin with plenty of water. Cover the irritated skin with an emollient. Remove contaminated clothing and shoes. Wash clothing before reuse. Thoroughly clean shoes before reuse. Get medical attention.

**Serious Skin Contact:**

Wash with a disinfectant soap and cover the contaminated skin with an anti-bacterial cream. Seek immediate medical attention.

**Inhalation:**

If inhaled, remove to fresh air. If not breathing, give artificial respiration. If breathing is difficult, give oxygen. Get medical attention if symptoms appear.

**Serious Inhalation:**

Evacuate the victim to a safe area as soon as possible. Loosen tight clothing such as a collar, tie, belt or waistband. If breathing is difficult, administer oxygen. If the victim is not breathing, perform mouth-to-mouth resuscitation. Seek medical attention.

**Ingestion:**

Do NOT induce vomiting unless directed to do so by medical personnel. Never give anything by mouth to an unconscious person. Loosen tight clothing such as a collar, tie, belt or waistband. Get medical attention if symptoms appear.

**Serious Ingestion:** Not available.

## Section 5: Fire and Explosion Data

**Flammability of the Product:** Flammable.

**Auto-Ignition Temperature:** 464°C (867.2°F)

**Flash Points:** CLOSED CUP: 24°C (75.2°F). (Tagliabue.) OPEN CUP: 37.8°C (100°F).

**Flammable Limits:** LOWER: 1% UPPER: 7%

**Products of Combustion:** These products are carbon oxides (CO, CO<sub>2</sub>).

**Fire Hazards in Presence of Various Substances:**

Highly flammable in presence of open flames and sparks, of heat. Non-flammable in presence of shocks.

**Explosion Hazards in Presence of Various Substances:**

Risks of explosion of the product in presence of mechanical impact: Not available. Slightly explosive in presence of open flames and sparks, of heat.

**Fire Fighting Media and Instructions:**

Flammable liquid, soluble or dispersed in water. SMALL FIRE: Use DRY chemical powder. LARGE FIRE: Use alcohol foam, water spray or fog. Cool containing vessels with water jet in order to prevent pressure build-up, autoignition or explosion.

**Special Remarks on Fire Hazards:** Vapors may travel to source of ignition and flash back.

**Special Remarks on Explosion Hazards:**

Vapors may form explosive mixtures with air. Containers may explode when heated. May polymerize explosively when heated. An attempt to chlorinate xylene with 1,3-Dichloro-5,5-dimethyl-2,4-imidazolidindione (dichlorohydrantoin) caused a violent explosion

## Section 6: Accidental Release Measures

**Small Spill:** Absorb with an inert material and put the spilled material in an appropriate waste disposal.

**Large Spill:**

Flammable liquid. Keep away from heat. Keep away from sources of ignition. Stop leak if without risk. Absorb with DRY earth, sand or other non-combustible material. Do not touch spilled material. Prevent entry into sewers, basements or confined

areas; dike if needed. Be careful that the product is not present at a concentration level above TLV. Check TLV on the MSDS and with local authorities.

## Section 7: Handling and Storage

### Precautions:

Keep away from heat. Keep away from sources of ignition. Ground all equipment containing material. Do not ingest. Do not breathe gas/fumes/ vapor/spray. Wear suitable protective clothing. In case of insufficient ventilation, wear suitable respiratory equipment. If ingested, seek medical advice immediately and show the container or the label. Avoid contact with skin and eyes. Keep away from incompatibles such as oxidizing agents, acids.

### Storage:

Store in a segregated and approved area. Keep container in a cool, well-ventilated area. Keep container tightly closed and sealed until ready for use. Avoid all possible sources of ignition (spark or flame).

## Section 8: Exposure Controls/Personal Protection

### Engineering Controls:

Provide exhaust ventilation or other engineering controls to keep the airborne concentrations of vapors below their respective threshold limit value. Ensure that eyewash stations and safety showers are proximal to the work-station location.

### Personal Protection:

Splash goggles. Lab coat. Vapor respirator. Be sure to use an approved/certified respirator or equivalent. Gloves.

### Personal Protection in Case of a Large Spill:

Splash goggles. Full suit. Vapor respirator. Boots. Gloves. A self contained breathing apparatus should be used to avoid inhalation of the product. Suggested protective clothing might not be sufficient; consult a specialist BEFORE handling this product.

### Exposure Limits:

TWA: 100 (ppm) [Canada] TWA: 435 (mg/m<sup>3</sup>) [Canada] TWA: 434 STEL: 651 (mg/m<sup>3</sup>) from ACGIH (TLV) [United States]  
TWA: 100 STEL: 150 (ppm) from ACGIH (TLV) [United States] Consult local authorities for acceptable exposure limits.

## Section 9: Physical and Chemical Properties

**Physical state and appearance:** Liquid.

**Odor:** Sweetish.

**Taste:** Not available.

**Molecular Weight:** 106.17 g/mole

**Color:** Colorless. Clear

**pH (1% soln/water):** Not available.

**Boiling Point:** 138.5°C (281.3°F)

**Melting Point:** -47.4°C (-53.3°F)

**Critical Temperature:** Not available.

**Specific Gravity:** 0.864 (Water = 1)

**Vapor Pressure:** 0.9 kPa (@ 20°C)

**Vapor Density:** 3.7 (Air = 1)

**Volatility:** Not available.

**Odor Threshold:** 1 ppm

**Water/Oil Dist. Coeff.:** The product is more soluble in oil;  $\log(\text{oil/water}) = 3.1$

**Ionicity (in Water):** Not available.

**Dispersion Properties:** Not available.

**Solubility:**

Insoluble in cold water, hot water. Miscible with absolute alcohol, ether, and many other organic liquids.

## Section 10: Stability and Reactivity Data

**Stability:** The product is stable.

**Instability Temperature:** Not available.

**Conditions of Instability:** Heat, ignition sources, incompatibles

**Incompatibility with various substances:** Reactive with oxidizing agents, acids.

**Corrosivity:** Non-corrosive in presence of glass.

**Special Remarks on Reactivity:** Store away from acetic acid, nitric acid, chlorine, bromine, and fluorine.

**Special Remarks on Corrosivity:** Not available.

**Polymerization:** Will not occur.

## Section 11: Toxicological Information

**Routes of Entry:** Absorbed through skin. Dermal contact. Eye contact. Inhalation.

**Toxicity to Animals:**

WARNING: THE LC50 VALUES HEREUNDER ARE ESTIMATED ON THE BASIS OF A 4-HOUR EXPOSURE. Acute oral toxicity (LD50): 2119 mg/kg [Mouse]. Acute dermal toxicity (LD50): >1700 mg/kg [Rabbit]. Acute toxicity of the vapor (LC50): 5000 4 hours [Rat].

**Chronic Effects on Humans:**

CARCINOGENIC EFFECTS: 3 (Not classifiable for human.) by IARC. May cause damage to the following organs: blood, kidneys, liver, mucous membranes, bone marrow, central nervous system (CNS).

**Other Toxic Effects on Humans:** Hazardous in case of skin contact (irritant, permeator), of ingestion, of inhalation.

**Special Remarks on Toxicity to Animals:**

Lowest Lethal Dose: LDL [Human] - Route: Oral; Dose: 50 mg/kg LCL [Man] - Route: Oral; Dose: 10000 ppm/6H

**Special Remarks on Chronic Effects on Humans:**

Detected in maternal milk in human. Passes through the placental barrier in animal. Embryotoxic and/or foetotoxic in animal. May cause adverse reproductive effects (male and female fertility (spontaneous abortion and fetotoxicity)) and birth defects based animal data.

**Special Remarks on other Toxic Effects on Humans:**

Acute Potential Health Effects: Skin: Causes skin irritation. Can be absorbed through skin. Eyes: Causes eye irritation. Inhalation: Vapor causes respiratory tract and mucous membrane irritation. May affect central nervous system and behavior (General anesthetic/CNS depressant with effects including headache, weakness, memory loss, irritability, dizziness, giddiness, loss of coordination and judgement, respiratory depression/arrest or difficulty breathing, loss of appetite, nausea, vomiting, shivering, and possible coma and death). May also affects blood, sense organs, liver, and peripheral nerves. Ingestion: May cause gastrointestinal irritation including abdominal pain, vomiting, and nausea. May also affect liver and urinary system/kidneys. May cause effects similar to those of acute inhalation. Chronic Potential Health Effects: Chronic inhalation may affect the urinary system (kidneys) blood (anemia), bone marrow (hyperplasia of bone marrow) brain/behavior/Central Nervous system. Chronic inhalation may also cause mucosal bleeding. Chronic ingestion may affect the liver and metabolism (loss of appetite) and may affect urinary system (kidney damage)



## Section 12: Ecological Information

**Ecotoxicity:** Not available.

**BOD5 and COD:** Not available.

**Products of Biodegradation:**

Possibly hazardous short term degradation products are not likely. However, long term degradation products may arise.

**Toxicity of the Products of Biodegradation:** The products of degradation are less toxic than the product itself.

**Special Remarks on the Products of Biodegradation:** Not available.

## Section 13: Disposal Considerations

**Waste Disposal:**

Waste must be disposed of in accordance with federal, state and local environmental control regulations.

## Section 14: Transport Information

**DOT Classification:** CLASS 3: Flammable liquid.

**Identification :** Xylenes UNNA: 1307 PG: III

**Special Provisions for Transport:** Not available.

## Section 15: Other Regulatory Information

**Federal and State Regulations:**

Connecticut hazardous material survey.: Xylenes Illinois chemical safety act: Xylenes New York acutely hazardous substances: Xylenes Rhode Island RTK hazardous substances: Xylenes Pennsylvania RTK: Xylenes Minnesota: Xylenes Michigan critical material: Xylenes Massachusetts RTK: Xylenes Massachusetts spill list: Xylenes New Jersey: Xylenes New Jersey spill list: Xylenes Louisiana spill reporting: Xylenes California Director's List of Hazardous Substances: Xylenes TSCA 8(b) inventory: Xylenes SARA 302/304/311/312 hazardous chemicals: Xylenes SARA 313 toxic chemical notification and release reporting: Xylenes CERCLA: Hazardous substances.: Xylenes: 100 lbs. (45.36 kg)

**Other Regulations:**

OSHA: Hazardous by definition of Hazard Communication Standard (29 CFR 1910.1200). EINECS: This product is on the European Inventory of Existing Commercial Chemical Substances.

**Other Classifications:**

**WHMIS (Canada):**

CLASS B-2: Flammable liquid with a flash point lower than 37.8°C (100°F). CLASS D-2A: Material causing other toxic effects (VERY TOXIC).

**DSCL (EEC):**

R10- Flammable. R21- Harmful in contact with skin. R36/38- Irritating to eyes and skin. S2- Keep out of the reach of children. S36/37- Wear suitable protective clothing and gloves. S46- If swallowed, seek medical advice immediately and show this container or label.

**HMIS (U.S.A.):**

**Health Hazard:** 2

**Fire Hazard:** 3

**Reactivity:** 0

**Personal Protection:** h

**National Fire Protection Association (U.S.A.):**

**Health:** 2

**Flammability:** 3

**Reactivity:** 0

**Specific hazard:**

**Protective Equipment:**

Gloves. Lab coat. Vapor respirator. Be sure to use an approved/certified respirator or equivalent. Wear appropriate respirator when ventilation is inadequate. Splash goggles.

**Section 16: Other Information**

**References:** Not available.

**Other Special Considerations:** Not available.

**Created:** 10/11/2005 12:54 PM

**Last Updated:** 11/06/2008 12:00 PM

*The information above is believed to be accurate and represents the best information currently available to us. However, we make no warranty of merchantability or any other warranty, express or implied, with respect to such information, and we assume no liability resulting from its use. Users should make their own investigations to determine the suitability of the information for their particular purposes. In no event shall ScienceLab.com be liable for any claims, losses, or damages of any third party or for lost profits or any special, indirect, incidental, consequential or exemplary damages, howsoever arising, even if ScienceLab.com has been advised of the possibility of such damages.*

## MATERIAL SAFETY DATA SHEET

### SECTION 1 ♦ PRODUCT AND COMPANY IDENTIFICATION

Explorer Pipeline Company  
6846 South Canton  
P.O. Box 2650  
Tulsa, Oklahoma 74101

**FOR EMERGENCY SOURCE INFORMATION CONTACT:**

- (918) 493 - 5100
- CHEMTREC: (800) 424-9300 (24 hour contact)
- CANUTEC: (613) 996-6666
- SETIQ: 91-800-00214

**TRADE NAMES/SYNONYMS:**

Methyl Tertiary Butyl Ether, Methyl Ether, Butyl Ether, or MTBE

**CHEMICAL FAMILY:** Alkyl Ethyl

**EPL Code:** 17

*This material safety data sheet represents the composite characteristics and properties of fungible petroleum hydrocarbons and other related substances transported by explorer pipeline company. The information presented was compiled from one or more product shipper sources and is intended to provide health and safety guidance for these fungible products. Individual shipper and manufacturer MSDSs are available at Explorer Pipeline Company's, Tulsa, Oklahoma, offices.*

### SECTION 2 \* HAZARDS IDENTIFICATION

#### EMERGENCY OVERVIEW

#### DANGER! EXTREMELY FLAMMABLE LIQUID

- Clear, colorless liquid with ether-like odor;
- Eye and mucous membrane irritant - effects central Nervous system - harmful or fatal if swallowed - aspiration hazard;
- High fire hazard. Keep away from heat, spark, open flame, and other ignition sources;
- Contact may cause eye, skin and mucous membrane irritation. Avoid prolonged breathing of vapors or mists;
- Inhalation may cause irritation, anesthetic effects (dizziness, nausea, headache, intoxication), and respiratory system effects;
- If ingested, do NOT induce vomiting, as this may cause chemical pneumonia (fluid in the lungs); and
- Obtain prompt medical attention. Keep Out of Reach of Children!

### SECTION 3 ▼ COMPOSITION/INFORMATION OF INGREDIENTS

INGREDIENT	CAS NUMBER	PERCENTAGE (%)
Methyl Tertiary Butyl Ether	1634-04-4	97+%

#### ACUTE

**GETTING IT IN YOUR EYE...**

- May cause minor eye irritation.

**GETTING IT ON YOUR SKIN...**

- No significant signs or symptoms indicative of any health hazard are expected to occur as a result of skin absorption exposure.
- May produce skin irritation.

**SWALLOWING IT...**

- The major health threat of ingestion occurs from the danger of aspiration (breathing) of liquid drops into the lungs, particularly from vomiting. Aspiration may result in chemical pneumonia (fluid in the lungs), severe lung damage, respiratory failure and even death.

**BREATHING IT...**

- Excessive exposure may cause irritation to the nose, throat, lungs and respiratory tract. Central nervous system (brain) effects may include headache, dizziness, loss of balance and coordination, unconsciousness, coma, respiratory failure, and death.

**CHRONIC**

- Medical information regarding special health effects is not conclusive.

**CANCER, REPRODUCTIVE AND GENETIC EFFECTS**

- This product has produced cancer, developmental and systemic toxicity in laboratory animals following repeated exposure. The significance of these results to human exposures has not been determined.

See Toxicological Information (Section 11) For More Information

**SECTION 4 + FIRST AID MEASURES**

**EYES:** In case of eye contact, immediately rinse with clean water for 20-30 minutes. Retract eyelids often. Obtain emergency medical attention if pain, blinking, tears or redness persist.

**SKIN:** Immediately remove contaminated clothing. Wash skin thoroughly with mild soap/water. Flush with lukewarm water for 15 minutes. If sticky, use waterless cleaner first.

**INGESTION:** If large quantity swallowed, give lukewarm water (pint) if victim completely conscious/alert. Do not induce vomiting/risk of damage to lungs exceeds poisoning risk. Obtain emergency medical attention.

**INHALATION:** If overcome by exposure, remove victim to fresh air immediately. Give oxygen or artificial respiration as needed. Obtain emergency medical attention. Prompt action is essential.

NOTE TO PHYSICIAN: TREAT SYMPTOMATICALLY AND SUPPORTIVELY

**SECTION 5 ⌘ FIRE FIGHTING MEASURES**

Releases flammable vapors below normal ambient temperatures. When mixed with air and exposed to ignition source, vapors can burn in open or explode if confined. Flammable vapors may be heavier than air. May travel long distances along ground before igniting/flashing back to vapor source.

**FLASH POINT:**(Method Used) -30°F

**FLAMMABLE LIMITS:** LEL: 1.0%  
UEL: 8.0%

**AUTOIGNITION TEMPERATURE:** 797°F

**EXTINGUISHING MEDIA:** Dry Chemical, CO<sub>2</sub>, Foam for Alcohols, Water spray, and fog to cool exposures

**HAZARDOUS REACTIONS/DECOMPOSITION:** Combustion may produce carbon monoxide, carbon dioxide, and acrid fumes. Incomplete combustion generates highly poisonous carbon monoxide and perhaps other toxic gases.

**SPECIAL INSTRUCTIONS:** Do not enter fire area without proper protection. Decomposition products possible. Fight fires from safe distance/protected location. Heat may build pressure/rupture closed containers, spreading fire, increasing risk of burns/injuries. Water may be ineffective due to low flash point. Even if material is water soluble, may not be practicable to extinguish fire by water dilution. Apply water spray/fog for cooling. Notify authorities if liquid enters sewer/public waters.

**SECTION 6 ❖ ACCIDENTAL RELEASE MEASURES**

- Flammable liquid. Release can cause fire/explosion. Liquids/vapors may ignite. Evacuate/limit access. Equip responders with proper protection. Kill all ignition sources. Stop release. Prevent flow to sewers/public waters. Notify fire/environmental authorities. Blanket with firefighting foam. Restrict water use for cleanup. Impound/recover large land spill. Soak up small spill with inert solids. Use suitable disposal containers. On water material partially soluble/may float or sink. Contain/minimize dispersion/collect. Disperse residue to reduce aquatic harm.

**SECTION 7 ✂ HANDLING AND STORAGE**

- Prior to working with this product workers should be trained on its proper handling and storage
- Store in tightly closed/properly vented containers away from heat/sparks/open flame/strong oxidizers. Use only non-sparking tools. Store drums with bung in up position. Carefully vent internal pressure before removing closure. Containers must be grounded before transfer. Electrical equipment should conform to National Electric Code. Handle used containers with care; residue may be flammable/explosive, unless blanketed with inert gas.
  - Isolate, vent, drain, wash, and purge equipment before maintenance. Remove all ignition sources, check atmosphere for explosiveness and oxygen deficiencies. Use adequate personal protective equipment. Observe precautions pertaining to confined space entry.

### SECTION 8 # EXPOSURE CONTROLS / PERSONAL PROTECTION

**ENGINEERING CONTROLS:** No special ventilation is usually required beyond that needed for normal comfort control.

**OTHER HYGIENIC AND WORK PRACTICES:** Emergency eye wash fountains and safety showers should be available in the immediate vicinity of any potential exposure. Use good personal hygiene practices. Wash hands before eating, drinking, smoking, or using toilet facilities. Promptly remove soiled clothing/wash thoroughly before reuse. Shower after work using plenty of soap and water.

#### EXPOSURE LIMITS

##### OSHA PEL

##### ACGIH TLV (2005)

#### METHYL TERT BUTYL ETHER

TWA	STEL	TWA	STEL
Not Applicable (N.A.)	N.A.	50 ppm	N.A.

#### PERSONAL PROTECTIVE EQUIPMENT

- **EYES:** Eye protection such as chemical splash goggles and/or face shield must be worn when possibility exists for eye contact due to splashing or spraying liquid, airborne particles, or vapor. Contact lenses should not be worn.
- **SKIN:** Depending on the conditions of use, protective gloves, apron, boots, head and face protection should be worn. This equipment should be cleaned thoroughly after each use.
- **RESPIRATORY PROTECTION:** No occupational exposure standards have been developed for this material. Where exposure through inhalation may occur from use, NIOSH/MSHA approved respiratory protection is recommended.

### SECTION 9 ⚡ PHYSICAL AND CHEMICAL PROPERTIES

<b>BOILING POINT (760 MM HG):</b> 131°F	<b>PERCENT VOLATILE BY VOLUME:</b> 100%
<b>SPECIFIC GRAVITY (H<sub>2</sub>O = 1):</b> 0.74 @ 68°F	<b>VISCOSITY UNITS, TEMP:</b> No Data
<b>FREEZING POINT:</b> -164°F	<b>VAPOR DENSITY (AIR =1):</b> 3.1
<b>VAPOR PRESSURE AT 68°F:</b> 75 mm Hg	<b>SOLUBILITY IN WATER:</b> Approximately 4% to 5%

**APPEARANCE AND ODOR:** Clear, colorless liquid with ether-like odor.

### SECTION 10 ⚡ STABILITY AND REACTIVITY

**CHEMICAL STABILITY:** Stable

**CONDITIONS TO AVOID:** High temperature, open flame or spark.

**OTHER PHYSICAL AND CHEMICAL PROPERTIES:** No Data

**MATERIALS TO AVOID:** Strong oxidizing agents, ungrounded electrical equipment, open flames and spark.

**HAZARDOUS POLYMERIZATION:** Not Expected to Occur

### SECTION 11 ☼ TOXICOLOGICAL INFORMATION

#### METHYL TERT BUTYL ETHER (MTBE)

Acute symptoms associated with human exposure to MTBE appear to be mild and transient. Breathing small amounts of MTBE for short periods may cause nose and throat irritation. In laboratory studies, rodents exposed to high doses of MTBE exhibited blood chemistry changes and liver and kidney abnormalities.

#### TOXICITY

Type Of Dose	Specie	Result	Type Of Dose	Specie	Result	Type Of Dose	Specie	Result
LD <sub>50</sub> (oral)	Mouse	3,500 mg/kg	LC <sub>50</sub> (inh)	Mouse	35,000 ppm	LD <sub>LO</sub> (oral)	Human	No Data Available

#### CARCINOGENICITY

<b>IARC</b>	Sufficient evidence in animals	Inadequate evidence in humans	Group 3: Possible human carcinogen
<b>NTP</b>	Not identified as a Known Carcinogen or Anticipated Human Carcinogen		

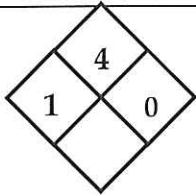
MATERIAL NAME: MTBE				MSDS # EPL-9	
<b>California (Prop 65):</b> Listed as carcinogen		<b>NIOSH:</b> Not Listed		<b>ACGIH:</b> A3 – Confirmed Animal	
<b>OSHA:</b> not classifiable as a human carcinogen					
<b>MUTAGENICITY, TERATOGENICITY AND REPRODUCTIVE EFFECTS</b>					
In laboratory studies, MTBE vapor exposure at the high dose concentration was associated with an increased incidence of liver tumors in female mice. Also, at high dose concentration exposures, MTBE was associated with an increased incidence of kidney and testicular (Leydig cell) tumors in male rats. There is no evidence that MTBE causes cancer in humans.					
<b>SECTION 12 * ECOLOGICAL INFORMATION</b>					
<b>ACUTE EFFECTS:</b> MTBE is considered moderately toxicity to aquatic life. Insufficient data are available to evaluate or predict the short-term effects to birds or land animals.					
<b>CHRONIC EFFECTS:</b> MTBE is considered moderately toxicity to aquatic life. Insufficient data are available to evaluate or predict the long-term effects to birds or land animals.					
<b>DISTRIBUTION AND PERSISTENCE IN THE ENVIRONMENT:</b> MTBE evaporates when exposed to air. It dissolves when mixed with water. Most direct releases of MTBE to the environment are to air. MTBE also evaporates from water and soil exposed to air. Once in air, it is expected to break down to other chemicals. Because it is a liquid that does not bind well to soil, MTBE that makes its way into the ground can move through the ground and enter groundwater. Plants and animals are not likely to store methyl tertiary-butyl ether..					
<b>SECTION 13 † DISPOSAL CONSIDERATIONS</b>					
Contaminated product/soil/water may be RCRA/OSHA hazardous waste due to low flash point. Use registered transporters. Dilute aqueous waste may biodegrade.					
<b>SECTION 14 ★ TRANSPORTATION INFORMATION</b>					
Not Meant To Be All Inclusive - Check Local, State, And Federal Laws And Regulations					
Agency	Shipping Name	Packing Group	Hazard Class	UN/NA #	
U.S. DOT	Methyl tert-butyl ether	II	Flammable Liquid	UN 2398	
<b>SECTION 15 ∩ REGULATORY INFORMATION</b>					
<b>CERCLA RQ's (40 CFR Part 302)</b>		MTBE - 1,000 pounds			
<b>RCRA</b>		Not Listed			
<b>SARA (40 CFR Part 355) TPQ's</b>		None of the ingredients are listed			
<b>SARA Title III Section 313</b>		All ingredients listed			
<b>California's Prop 65</b>		All ingredients listed			
<b>OSHA</b>		All ingredients are listed as hazardous under 29 CFR 1910.1200			
<b>SECTION 16 ☼ OTHER INFORMATION</b>					
<b>NFPA 704 LABEL:</b>			<b>HMIS LABEL</b>		
			1-4-0		
<b>MSDS REVISIONS:</b> Change in Format and update of Information					
<b>MSDS CREATION DATE:</b> July 1997			<b>REVISION #1:</b> 01/03/06		

**DISCLAIMER**

The information in this MSDS was obtained from sources which we believe are reliable. **HOWEVER, THE INFORMATION IS PROVIDED WITHOUT ANY WARRANTY, EXPRESS OR IMPLIED, REGARDING ITS ACCURACY.** Some conditions or methods of handling, storage, use and disposal of the product are beyond our control and may be beyond our knowledge. **FOR THIS AND OTHER REASONS, WE DO NOT ASSUME RESPONSIBILITY AND EXPRESSLY DISCLAIM LIABILITY FOR LOSS, DAMAGE OR EXPENSE ARISING OUT OR IN ANY WAY CONNECTED WITH THE HANDLING, STORAGE, USE OR DISPOSAL OF THE PRODUCT.** All product measurements such as flash point, *etc.* are considered approximate values. All data provided by Explorer Pipeline Company.

This MSDS was prepared and is to be used only for this product. If the product is used as a component in another product, such as refined petroleum hydrocarbon mixtures, this MSDS information may not be applicable.

MSDS DEVELOPER: \_\_\_\_\_

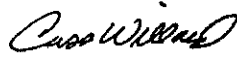
  
Cass Willard, CIHDATE: 01/03/06

# Material Safety Data Sheet

## Fuel Oil

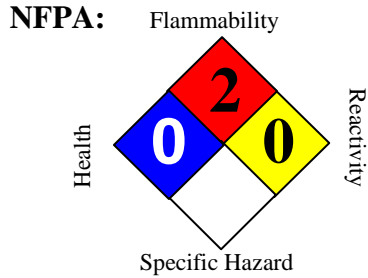

### SECTION 1. PRODUCT AND COMPANY IDENTIFICATION

<b>Product name</b>	:	Fuel Oil			
<b>Synonyms</b>	:	Bunkers, Black Fuel Oil, MFO, Industrial Fuel Oil, 6 Oil, Slurry Fuel Oil, RFO, Refinery Fuel Oil, High Sulfur Fuel Oil, HSFO, IFO-30, IFO-180, IFO-380, IFO-510, IFO-700, Bunker C, Bunker Fuel Oil, Marine Fuel Oil, Decant Oil, Utility Fuel Oil, LSFO, Six Oil, 888100008793			
<b>SDS Number</b>	:	888100008793	<b>Version</b>	:	1.20
<b>Product Use Description</b>	:	Fuel, Intermediate Stream			
<b>Company</b>	:	For: Tesoro Refining & Marketing Co. 19100 Ridgewood Parkway, San Antonio, TX 78259			
<b>Tesoro Call Center</b>	:	(877) 783-7676	<b>Chemtrec (Emergency Contact)</b>	:	(800) 424-9300

### SECTION 2. HAZARDS IDENTIFICATION

<b>Classifications</b>	Flammable Liquid – Category 4 Carcinogenicity – Category 1B Toxic to Reproduction – Category 1B Specific Target Organ Toxicity (Repeated Exposure) – Category 2 Acute Toxicity – Inhalation – Category 4 Acute Aquatic Toxicity – Category 3
<b>Pictograms</b>	
<b>Signal Word</b>	<b>DANGER</b>
<b>Hazard Statements</b>	Combustible liquid. May cause cancer from prolonged and repeated skin contact. May damage fertility or the unborn child. May cause damage to liver, kidney and nervous system through prolonged or repeated exposure. Harmful if inhaled. Harmful to aquatic life Skin and eye irritant. May contain and release toxic hydrogen sulfide (H2S) gas.



**Precautionary Statements****Prevention**

Obtain special instructions before use.  
 Do not handle until all safety precautions have been read and understood.  
 Keep away from flames and hot surfaces. No smoking.  
 Wear gloves, eye protection and face protection as needed to prevent skin and eye contact with liquid.  
 Wash hands or liquid-contacted skin thoroughly after handling.  
 Do not eat, drink or smoke when using this product.  
 Do not breathe vapors or mists.  
 Use only outdoors or in a well-ventilated area

**Response**

In case of fire: Use dry chemical, CO<sub>2</sub>, water spray or fire fighting foam to extinguish.  
 Get medical advice or attention if you feel unwell, are exposed, or become concerned.  
 If on skin (or hair): Take off immediately all contaminated clothing. Rinse skin with water or shower.  
 If in eye: Rinse cautiously with water for several minutes. Remove contact lenses, if present and easy to do. Continue rinsing.  
 If skin or eye irritation persists, get medical attention.  
 If inhaled: Remove person to fresh air and keep comfortable for breathing.  
 Immediately call or doctor or emergency medical provider

**Storage**

Store in a well ventilated place. Keep cool. Store locked up. Keep container tightly closed . Use only approved containers.

**Disposal**

Dispose of contents/containers to approved disposal site in accordance with local, regional, national, and/or international regulations.

**SECTION 3. COMPOSITION/INFORMATION ON INGREDIENTS**

Component	CAS-No.	Weight %
Clarified oils (petroleum), catalytic cracked; Heavy Fuel oil	64741-62-4	100%
Polycyclic aromatic compounds (PACs or PNAs)		Typically 1.5%
Benzo[a]pyrene; Benzo[def]chrysene	50-32-8	Trace to 0.2%
Hydrogen Sulfide	7783-06-4	Trace to 0.2%
Sulfur (for waters within 25 miles of California shores)	17704-34-9	Trace to 0.1%
Sulfur (for waters within 200 miles of American shores)	17704-34-9	Trace to 1.0%
Sulfur (for International waters)	17704-34-9	Trace to 3.5%

**SECTION 4. FIRST AID MEASURES**

**Inhalation** : Move to fresh air. Give oxygen. If breathing is irregular or stopped, administer artificial respiration. Seek medical attention immediately.

**Skin contact** : Take off all contaminated clothing immediately. Wash off immediately with soap

	and plenty of water. Wash contaminated clothing before re-use. If skin irritation persists, call a physician.
<b>Eye contact</b>	: Remove contact lenses. Rinse immediately with plenty of water, also under the eyelids, for at least 15 minutes. If eye irritation persists, consult a specialist.
<b>Ingestion</b>	: Do NOT induce vomiting. Do not give liquids. Seek medical attention immediately. If vomiting does occur naturally, keep head below the hips to reduce the risks of aspiration. Monitor for breathing difficulties. Small amounts of material which enter the mouth should be rinsed out until the taste is dissipated.
<b>Notes to physician</b>	: Symptoms: Dizziness, Discomfort, Headache, Nausea, Disorder, Vomiting, Liver disorders, Kidney disorders, Aspiration may cause pulmonary edema and pneumonitis.

## SECTION 5. FIRE-FIGHTING MEASURES

<b>Suitable extinguishing media</b>	: Carbon dioxide (CO <sub>2</sub> ), Water spray, Dry chemical, Foam, Keep containers and surroundings cool with water spray.
<b>Specific hazards during fire fighting</b>	: Isolate area around container involved in fire. Cool tanks, shells, and containers exposed to fire and excessive heat with water. For massive fires the use of unmanned hose holders or monitor nozzles may be advantageous to further minimize personnel exposure. Major fires may require withdrawal, allowing the tank to burn. Large storage tank fires typically require specially trained personnel and equipment to extinguish the fire, often including the need for properly applied fire fighting foam.
<b>Special protective equipment for fire-fighters</b>	: Firefighting activities that may result in potential exposure to high heat, smoke or toxic by-products of combustion should require NIOSH/MSHA- approved pressure-demand self-contained breathing apparatus with full facepiece and full protective clothing.
<b>Further information</b>	: Flammable vapor production at ambient temperature in the open is expected to be minimal, as the material is generally wet. However, depending on oil content and conditions, it is possible flammable vapors could accumulate in the headspace of storage containers, presenting a flammability and explosion hazard. Being heavier than air, vapors may travel long distances to an ignition source and flash back. Runoff to sewer may cause fire or explosion hazard.

## SECTION 6. ACCIDENTAL RELEASE MEASURES

<b>Personal precautions</b>	: Evacuate nonessential personnel and remove or secure all ignition sources. Consider wind direction; stay upwind and uphill, if possible. Evaluate the direction of product travel, diking, sewers, etc. to contain spill areas.
<b>Environmental precautions</b>	: Carefully contain and stop the source of the spill, if safe to do so. Protect bodies of water by diking, absorbents, or absorbent boom, if possible. Do not flush down sewer or drainage systems, unless system is designed and permitted to handle such material.
<b>Methods for cleaning up</b>	: Take up with sand or oil absorbing materials. Carefully vacuum, shovel, scoop or sweep up into a waste container for reclamation or disposal.

## SECTION 7. HANDLING AND STORAGE

<b>Precautions for safe handling</b>	: Keep away from fire, sparks and heated surfaces. No smoking near areas where
--------------------------------------	--

material is stored or handled. The product should only be stored and handled in areas with intrinsically safe electrical classification.

Hydrocarbon liquids including this product can act as a non-conductive flammable liquid (or static accumulators), and may form ignitable vapor-air mixtures in storage tanks or other containers. Precautions to prevent static-initated fire or explosion during transfer, storage or handling, include but are not limited to these examples:

- (1) Ground and bond containers during product transfers. Grounding and bonding may not be adequate protection to prevent ignition or explosion of hydrocarbon liquids and vapors that are static accumulators.
- (2) Special slow load procedures for "switch loading" must be followed to avoid the static ignition hazard that can exist when higher flash point material (such as fuel oil or diesel) is loaded into tanks previously containing low flash point products (such as gasoline or naphtha).
- (3) Storage tank level floats must be effectively bonded.

For more information on precautions to prevent static-initated fire or explosion, see NFPA 77, Recommended Practice on Static Electricity (2007), and API Recommended Practice 2003, Protection Against Ignitions Arising Out of Static, Lightning, and Stray Currents (2008).

**Conditions for storage, including any incompatibilities**

- : Keep away from flame, sparks, excessive temperatures and open flame. Use approved containers. Keep containers closed and clearly labeled. Empty or partially full product containers or vessels may contain explosive vapors. Do not pressurize, cut, heat, weld or expose containers to sources of ignition. Store in a well-ventilated area. The storage area should comply with NFPA 30 "Flammable and Combustible Liquid Code". The cleaning of tanks previously containing this product should follow API Recommended Practice (RP) 2013 "Cleaning Mobile Tanks In Flammable and Combustible Liquid Service" and API RP 2015 "Cleaning Petroleum Storage Tanks".

Hydrogen sulfide may accumulate in tanks and bulk transport compartments. Consider appropriate respiratory protection (see Section 8). Stand upwind. Avoid vapors when opening hatches and dome covers. Confined spaces should be ventilated and gas tested prior to entry.

Keep away from food, drink and animal feed. Incompatible with oxidizing agents. Incompatible with acids.

No decomposition if stored and applied as directed.

## SECTION 8. EXPOSURE CONTROLS / PERSONAL PROTECTION

### Exposure Guidelines

List	Components	CAS-No.	Type:	Value
OSHA	Polycyclic aromatic compounds (or coal tar pitch volatiles – benzene soluble)		PEL	0.2 mg/m <sup>3</sup>
	Clarified oils (petroleum), catalytic cracked; Heavy Fuel oil	64741-62-4	PEL	5 mg/m <sup>3</sup> (as mineral oil mist)
	Hydrogen Sulfide	7783-06-4	STEL	20 ppm
ACGIH	Hydrogen Sulfide	7783-06-4	TWA	1 ppm
		7783-06-4	STEL	5 ppm

	Clarified oils (petroleum), catalytic cracked; Heavy Fuel oil	64741-62-4	TWA	0.2 mg/m <sup>3</sup> (as mineral oil) Sum of 15 NTP-listed polynuclear aromatic hydrocarbons 0.005 mg/m <sup>3</sup>
	Polycyclic aromatic compounds (or coal tar pitch volatiles – benzene soluble)		TWA	0.2 mg/m <sup>3</sup>

- Engineering measures** : Use adequate ventilation to keep gas and vapor concentrations of this product below occupational exposure and flammability limits, particularly in confined spaces.
- Eye protection** : Safety glasses or goggles are recommended where there is a possibility of splashing or spraying.
- Hand protection** : Gloves constructed of nitrile, neoprene, or PVC are recommended.
- Skin and body protection** : Chemical protective clothing such as DuPont Tyvek QC, TyChem® or equivalent, recommended based on degree of exposure. The resistance of specific material may vary from product to product as well as with degree of exposure.
- Respiratory protection** : If hydrogen sulfide concentration may exceed permissible exposure limit, a positive-pressure SCBA or Type C supplied air respirator with escape bottle is required as respiratory protection. If hydrogen sulfide concentration is below H<sub>2</sub>S permissible exposure limit a NIOSH/ MSHA-approved air-purifying respirator with acid gas cartridges may be acceptable for odor control, but continuous air monitoring for H<sub>2</sub>S is recommended. Protection provided by air-purifying respirators is limited. Use a NIOSH/ MSHA-approved positive-pressure supplied-air respirator if there is a potential for uncontrolled release, exposure levels are not known, in oxygen-deficient atmospheres, or any other circumstance where an air-purifying respirator may not provide adequate protection. Refer to OSHA 29 CFR 1910.134, ANSI Z88.2-1992, NIOSH Respirator Decision Logic, and the manufacturer for additional guidance on respiratory protection selection.
- Work / Hygiene practices** : Emergency eye wash capability should be available in the near proximity to operations presenting a potential splash exposure. Use good personal hygiene practices. Avoid repeated and/or prolonged skin exposure. Wash hands before eating, drinking, smoking, or using toilet facilities. Do not use as a cleaning solvent on the skin. Do not use solvents or harsh abrasive skin cleaners for washing this product from exposed skin areas. Waterless hand cleaners are effective. Promptly remove contaminated clothing and launder before reuse. Use care when laundering to prevent the formation of flammable vapors which could ignite via washer or dryer. Consider the need to discard contaminated leather shoes and gloves.

## SECTION 9. PHYSICAL AND CHEMICAL PROPERTIES

<b>Appearance</b>	Dark green to brown or black liquid
<b>Odor</b>	Petroleum asphalt odor

<b>Odor threshold</b>	No data available
<b>pH</b>	Not applicable
<b>Melting point/freezing point</b>	32° - 80°C (89.6° - 176°F)
<b>Initial boiling point &amp; range</b>	154 - 372 °C (310° - 702 °F)
<b>Flash point</b>	60°C (140°F) minimum
<b>Evaporation rate</b>	Higher initially and declining as lighter components evaporate
<b>Flammability (solid, gas)</b>	Flammable vapor released by heated liquid
<b>Upper explosive limit</b>	No data available
<b>Lower explosive limit</b>	No data available
<b>Vapor pressure</b>	210 Pa at 25°C
<b>Vapor density (air = 1)</b>	>5
<b>Relative density (water = 1)</b>	>0.9 to 1.2 g/mL
<b>Solubility (in water)</b>	6 to 1400 mg/L at 25°C
<b>Partition coefficient (n-octanol/water)</b>	3.4 to 5 as log Pow at 25°C
<b>Auto-ignition temperature</b>	>176°C (>350 °F)
<b>Decomposition temperature</b>	Will evaporate or boil and possibly ignite before decomposition occurs.
<b>Kinematic viscosity</b>	>300 cST typical at 40°C

## SECTION 10. STABILITY AND REACTIVITY

<b>Reactivity</b>	: Vapors may form explosive mixtures with air. Hazardous polymerization does not occur.
<b>Chemical Stability</b>	Stable under normal conditions.
<b>Possibility of hazardous reactions</b>	Can react with strong oxidizing agents and peroxides. Keep away from strong acids and bases.
<b>Conditions to avoid</b>	Avoid high temperatures, open flames, sparks, welding, smoking and other ignition sources. Keep away from strong oxidizers.
<b>Hazardous decomposition products</b>	Carbon monoxide, carbon dioxide and noncombusted hydrocarbons (smoke).

## SECTION 11. TOXICOLOGICAL INFORMATION

<b>Inhalation</b>	: Because of its low vapor pressure, this product presents a minimal inhalation hazard at ambient temperature. Upon heating, fumes may be evolved. Inhalation of fumes or mist may result in respiratory tract irritation and central nervous system (brain) effects may include headache, dizziness, loss of balance and coordination, unconsciousness, coma, respiratory failure, and death. The burning of any hydrocarbon as a fuel in an area without adequate ventilation may result in hazardous levels of combustion products, including carbon monoxide, and inadequate oxygen levels, which may cause unconsciousness, suffocation, and death. Irritating and toxic hydrogen sulfide gas may be present. Greater than 15 - 20 ppm continuous exposure can cause mucous membrane and respiratory tract
-------------------	---

irritation. 50 - 500 ppm can cause headache, nausea, and dizziness. Continued exposure at these levels can lead to loss of reasoning and balance, difficulty in breathing, fluid in the lungs, and possible loss of consciousness. Greater than 500 ppm can cause rapid unconsciousness due to respiratory paralysis and death by suffocation unless the victim is removed from exposure and successfully resuscitated. Greater than 1000 ppm can cause immediate unconsciousness and death if not promptly revived. After-effects from overexposure are not anticipated except what would be expected if the victim was without oxygen for more than 3 to 5 minutes (asphyxiation). The "rotten egg" odor of hydrogen sulfide is not a reliable indicator for warning of exposure, since olfactory fatigue (loss of smell) readily occurs, especially at concentrations above 50 ppm. At high concentrations, the victim may not even recognize the odor before becoming unconscious.

**Skin irritation**

May cause skin irritation with prolonged or repeated contact. Practically non-toxic if absorbed following acute (single) exposure. Exposure may cause a phototoxicity reaction: liquid or mist on the skin may produce a painful sunburn reaction when exposed to sunlight. Product may be hot which could cause 1st, 2nd, or 3rd degree thermal burns.

**Eye irritation**

May cause irritation, experienced as mild discomfort and seen as slight excess redness of the eye.

**Ingestion**

This material has a low order of acute toxicity. If large quantities are ingested, nausea, vomiting and diarrhea may result. Ingestion may also cause effects similar to inhalation of the product. Could present an aspiration hazard if liquid is inhaled into lungs, particularly from vomiting after ingestion. Aspiration may result in chemical pneumonia, severe lung damage, respiratory failure and even death.

**Further information**

This material contains polynuclear aromatic hydrocarbons (PNAs), some of which are animal carcinogens. Studies have shown that similar products produce skin cancer or skin tumors in laboratory animals following repeated applications without washing or removal. The significance of this finding to human exposure has not been determined. Other studies with active skin carcinogens have shown that washing the animal's skin with soap and water between applications reduced tumor formation. The presence of carcinogenic PNAs indicates that precautions should be taken to minimize repeated and prolonged inhalation of fumes or mists. Dermal application of gas oil to rats resulted in limited evidence of liver damage (i.e., increased liver weight and changes in hepatic serum enzyme activity) and bone marrow toxicity (hypoplasia and decreased hemoglobin.) Petroleum industry experience indicates that a program providing for good personal hygiene, proper use of personal protective equipment, and minimizing the repeated and prolonged exposure to liquids and fumes, is effective in reducing or eliminating the carcinogenic risk of high boiling aromatic oils (polynuclear aromatic hydrocarbons) to humans.

Liver and kidney injuries may occur.

Components of the product may affect the nervous system.

**Component:**

**Clarified oils (petroleum), catalytic cracked; Heavy Fuel oil**

64741-62-4 Acute oral toxicity: LD50 rat  
Dose: 4,320 mg/kg

Acute dermal toxicity: LD50 rabbit  
Dose: 2,001 mg/kg

Skin irritation: Classification: Irritating to skin.  
Result: Mild skin irritation

Eye irritation: Classification: Irritating to eyes.  
Result: Mild eye irritation

Carcinogenicity: Animal experiments showed a statistically significant number of tumors.

### Carcinogenicity

<b>NTP</b>	Benzo[a]pyrene; Benzo[def]chrysene (CAS-No.: 50-32-8)
<b>IARC</b>	Benzo[a]pyrene; Benzo[def]chrysene (CAS-No.: 50-32-8)
<b>OSHA</b>	No component of this product present at levels greater than or equal to 0.1% is identified as a carcinogen or potential carcinogen by OSHA.
<b>CA Prop 65</b>	WARNING! This product contains a chemical known to the State of California to cause cancer. Benzo[a]pyrene; Benzo[def]chrysene (CAS-No.: 50-32-8)

## SECTION 12. ECOLOGICAL INFORMATION

**Additional ecological information** : Keep out of sewers, drainage areas, and waterways. Report spills and releases, as applicable, under Federal and State regulations.

## SECTION 13. DISPOSAL CONSIDERATIONS

**Disposal** : Consult federal, state and local waste regulations to determine appropriate waste characterization of material and allowable disposal methods.

## SECTION 14. TRANSPORT INFORMATION

<b>CFR</b>	
Proper shipping name	: Not regulated if shipped below 140°F (60°C) Elevated temperature liquid, flammable (if shipped above 140°F (60°C)).
UN-No.	: Not regulated if shipped below 140°F (60°C) 3256 if shipped above 140°F (60°C)
Class	: 9
Packing group	: III
Hazard inducer	: (Clarified oils (petroleum), catalytic cracked; Heavy Fuel oil)
<b>TDG</b>	
Proper shipping name	: Not regulated if shipped below 140°F (60°C) Elevated temperature liquid, flammable (if shipped above 140°F (60°C)).
UN-No.	: Not regulated if shipped below 140°F (60°C) 3256 if shipped above 140°F (60°C)
Class	: 9
Packing group	: III
Hazard inducer	: (Clarified oils (petroleum), catalytic cracked; Heavy Fuel oil)
<b>IATA Cargo Transport</b>	
UN-No.	: Not regulated if shipped below 140°F (60°C) 3256 if shipped above 140°F (60°C)
Class	: Not regulated if shipped below 140°F (60°C) Not permitted for transport (at 140°F (60°C) or higher temperature) 9

**IATA Passenger Transport**

UN-No. : Not regulated if shipped below 140°F (60°C)  
3256 if shipped above 140°F (60°C)

Class : Not regulated if shipped below 140°F (60°C)  
Not permitted for transport (at 140°F (60°C) or higher temperature)  
9

**IMDG-Code**

UN-No. : Not regulated if shipped below 140°F (60°C)  
3256 if shipped above 140°F (60°C)

Description of the goods : Elevated temperature liquid, n.o.s.  
(Clarified oils (petroleum), catalytic cracked; Heavy Fuel oil)

Class :  
Not regulated if shipped below 140°F (60°C)  
Not permitted for transport (at 140°F (60°C) or higher temperature)  
9

Packaging group : III

IMDG-Labels : 9

EmS Number : F-A S-P

Marine pollutant : No

**SECTION 15. REGULATORY INFORMATION****CERCLA SECTION 103 and SARA SECTION 304 (RELEASE TO THE ENVIROMENT)**

The CERCLA definition of hazardous substances contains a "petroleum exclusion" clause which exempts crude oil. Fractions of crude oil, and products (both finished and intermediate) from the crude oil refining process and any indigenous components of such from the CERCLA Section 103 reporting requirements. However, other federal reporting requirements, including SARA Section 304, as well as the Clean Water Act may still apply.

TSCA Status : On TSCA Inventory

DSL Status : All components of this product are on the Canadian DSL list.

SARA 311/312 Hazards : Fire Hazard  
Acute Health Hazard  
Chronic Health Hazard

SARA III US. EPA Emergency Planning and Community Right-To-Know Act (EPCRA) SARA Title III Section 313 Toxic Chemicals (40 CFR 372.65) - Supplier Notification Required

**Components** CAS-No.

**Benzo[a]pyrene; Benzo[def]chrysene** 50-32-8

SARA III US. EPA Emergency Planning and Community Right-To-Know Act (EPCRA) SARA Title III Section 302 Extremely Hazardous Substance (40 CFR355, Appendix A)

**Components** CAS-No.

PENN RTK US. Pennsylvania Worker and Community Right-to-Know Law (34 Pa. Code Chap. 301-323)

**Components** CAS-No.

**Clarified oils (petroleum), catalytic cracked; Heavy Fuel oil** 64741-62-4

**Benzo[a]pyrene; Benzo[def]chrysene** 50-32-8

MASS RTK US. Massachusetts Commonwealth's Right-to-Know Law (Appendix A to 105 Code of Massachusetts Regulations Section 670.000)



**Components**CAS-No.**Benzo[a]pyrene; Benzo[def]chrysene**

50-32-8

NJ RTK

US. New Jersey Worker and Community Right-to-Know Act (New Jersey Statute Annotated Section 34:5A-5)

**Components**CAS-No.**Clarified oils (petroleum), catalytic cracked; Heavy Fuel oil**

64741-62-4

**Benzo[a]pyrene; Benzo[def]chrysene**

50-32-8

California Prop. 65

: WARNING! This product contains a chemical known in the State of California to cause cancer.

Benzo[a]pyrene;  
Benzo[def]chrysene

50-32-8

**SECTION 16. OTHER INFORMATION**Further information

The information provided in this Safety Data Sheet is correct to the best of our knowledge, information and belief at the date of its publication. The information given is designed only as guidance for safe handling, use, processing, storage, transportation, disposal and release and is not to be considered a warranty or quality specification. The information relates only to the specific material designated and may not be valid for such material used in combination with any other materials or in any process, unless specified in the text.

**Revision Date** : 07/26/2012

65, 66, 121, 295, 296, 347, 1003, 1006, 1007, 1009, 1010, 1022, 1054, 1083, 1084, 1085, 1089, 1586, 1886

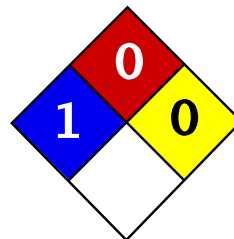

Health	1
Fire	0
Reactivity	0
Personal Protection	E

## Material Safety Data Sheet Lead MSDS

### Section 1: Chemical Product and Company Identification

**Product Name:** Lead

**Catalog Codes:** SLL1291, SLL1669, SLL1081, SLL1459, SLL1834

**CAS#:** 7439-92-1

**RTECS:** OF7525000

**TSCA:** TSCA 8(b) inventory: Lead

**CI#:** Not available.

**Synonym:** Lead Metal, granular; Lead Metal, foil; Lead Metal, sheet; Lead Metal, shot

**Chemical Name:** Lead

**Chemical Formula:** Pb

**Contact Information:**

**Sciencelab.com, Inc.**  
14025 Smith Rd.  
Houston, Texas 77396

US Sales: **1-800-901-7247**  
International Sales: **1-281-441-4400**

Order Online: [ScienceLab.com](http://ScienceLab.com)

**CHEMTREC (24HR Emergency Telephone), call:**  
1-800-424-9300

**International CHEMTREC, call:** 1-703-527-3887

**For non-emergency assistance, call:** 1-281-441-4400

### Section 2: Composition and Information on Ingredients

**Composition:**

Name	CAS #	% by Weight
Lead	7439-92-1	100

**Toxicological Data on Ingredients:** Lead LD50: Not available. LC50: Not available.

### Section 3: Hazards Identification

**Potential Acute Health Effects:** Slightly hazardous in case of skin contact (irritant), of eye contact (irritant), of ingestion, of inhalation.

**Potential Chronic Health Effects:**

Slightly hazardous in case of skin contact (permeator).

**CARCINOGENIC EFFECTS:** Classified A3 (Proven for animal.) by ACGIH, 2B (Possible for human.) by IARC.

**MUTAGENIC EFFECTS:** Not available.

**TERATOGENIC EFFECTS:** Not available.

**DEVELOPMENTAL TOXICITY:** Not available.

The substance may be toxic to blood, kidneys, central nervous system (CNS).

Repeated or prolonged exposure to the substance can produce target organs damage.

## Section 4: First Aid Measures

### Eye Contact:

Check for and remove any contact lenses. In case of contact, immediately flush eyes with plenty of water for at least 15 minutes. Get medical attention if irritation occurs.

**Skin Contact:** Wash with soap and water. Cover the irritated skin with an emollient. Get medical attention if irritation develops.

**Serious Skin Contact:** Not available.

### Inhalation:

If inhaled, remove to fresh air. If not breathing, give artificial respiration. If breathing is difficult, give oxygen. Get medical attention.

**Serious Inhalation:** Not available.

### Ingestion:

Do NOT induce vomiting unless directed to do so by medical personnel. Never give anything by mouth to an unconscious person. If large quantities of this material are swallowed, call a physician immediately. Loosen tight clothing such as a collar, tie, belt or waistband.

**Serious Ingestion:** Not available.

## Section 5: Fire and Explosion Data

**Flammability of the Product:** May be combustible at high temperature.

**Auto-Ignition Temperature:** Not available.

**Flash Points:** Not available.

**Flammable Limits:** Not available.

**Products of Combustion:** Some metallic oxides.

**Fire Hazards in Presence of Various Substances:** Non-flammable in presence of open flames and sparks, of shocks, of heat.

### Explosion Hazards in Presence of Various Substances:

Risks of explosion of the product in presence of mechanical impact: Not available.

Risks of explosion of the product in presence of static discharge: Not available.

### Fire Fighting Media and Instructions:

SMALL FIRE: Use DRY chemical powder.

LARGE FIRE: Use water spray, fog or foam. Do not use water jet.

**Special Remarks on Fire Hazards:** When heated to decomposition it emits highly toxic fumes of lead.

**Special Remarks on Explosion Hazards:** Not available.

## Section 6: Accidental Release Measures

### Small Spill:

Use appropriate tools to put the spilled solid in a convenient waste disposal container. Finish cleaning by spreading water on the contaminated surface and dispose of according to local and regional authority requirements.

### Large Spill:

Use a shovel to put the material into a convenient waste disposal container. Finish cleaning by spreading water on the contaminated surface and allow to evacuate through the sanitary system. Be careful that the product is not

present at a concentration level above TLV. Check TLV on the MSDS and with local authorities.

## Section 7: Handling and Storage

### Precautions:

Keep locked up.. Keep away from heat. Keep away from sources of ignition. Empty containers pose a fire risk, evaporate the residue under a fume hood. Ground all equipment containing material. Do not ingest. Do not breathe dust. Wear suitable protective clothing. If ingested, seek medical advice immediately and show the container or the label. Keep away from incompatibles such as oxidizing agents.

**Storage:** Keep container tightly closed. Keep container in a cool, well-ventilated area.

## Section 8: Exposure Controls/Personal Protection

### Engineering Controls:

Use process enclosures, local exhaust ventilation, or other engineering controls to keep airborne levels below recommended exposure limits. If user operations generate dust, fume or mist, use ventilation to keep exposure to airborne contaminants below the exposure limit.

**Personal Protection:** Safety glasses. Lab coat. Dust respirator. Be sure to use an approved/certified respirator or equivalent. Gloves.

### Personal Protection in Case of a Large Spill:

Splash goggles. Full suit. Dust respirator. Boots. Gloves. A self contained breathing apparatus should be used to avoid inhalation of the product. Suggested protective clothing might not be sufficient; consult a specialist BEFORE handling this product.

### Exposure Limits:

TWA: 0.05 (mg/m<sup>3</sup>) from ACGIH (TLV) [United States]

TWA: 0.05 (mg/m<sup>3</sup>) from OSHA (PEL) [United States]

TWA: 0.03 (mg/m<sup>3</sup>) from NIOSH [United States]

TWA: 0.05 (mg/m<sup>3</sup>) [Canada] Consult local authorities for acceptable exposure limits.

## Section 9: Physical and Chemical Properties

**Physical state and appearance:** Solid. (Metal solid.)

**Odor:** Not available.

**Taste:** Not available.

**Molecular Weight:** 207.21 g/mole

**Color:** Bluish-white. Silvery. Gray

**pH (1% soln/water):** Not applicable.

**Boiling Point:** 1740°C (3164°F)

**Melting Point:** 327.43°C (621.4°F)

**Critical Temperature:** Not available.

**Specific Gravity:** 11.3 (Water = 1)

**Vapor Pressure:** Not applicable.

**Vapor Density:** Not available.

**Volatility:** Not available.

**Odor Threshold:** Not available.

**Water/Oil Dist. Coeff.:** Not available.

**Ionicity (in Water):** Not available.

**Dispersion Properties:** Not available.

**Solubility:** Insoluble in cold water.

## Section 10: Stability and Reactivity Data

**Stability:** The product is stable.

**Instability Temperature:** Not available.

**Conditions of Instability:** Incompatible materials, excess heat

**Incompatibility with various substances:** Reactive with oxidizing agents.

**Corrosivity:** Non-corrosive in presence of glass.

**Special Remarks on Reactivity:**

Can react vigorously with oxidizing materials.

Incompatible with sodium carbide, chlorine trifluoride, trioxane + hydrogen peroxide, ammonium nitrate, sodium azide, disodium acetylide, sodium acetylide, hot concentrated nitric acid, hot concentrated hydrochloric acid, hot concentrated sulfuric acid, zirconium.

**Special Remarks on Corrosivity:** Not available.

**Polymerization:** Will not occur.

## Section 11: Toxicological Information

**Routes of Entry:** Absorbed through skin. Inhalation. Ingestion.

**Toxicity to Animals:**

LD50: Not available.

LC50: Not available.

**Chronic Effects on Humans:**

CARCINOGENIC EFFECTS: Classified A3 (Proven for animal.) by ACGIH, 2B (Possible for human.) by IARC.

May cause damage to the following organs: blood, kidneys, central nervous system (CNS).

**Other Toxic Effects on Humans:** Slightly hazardous in case of skin contact (irritant), of ingestion, of inhalation.

**Special Remarks on Toxicity to Animals:** Not available.

**Special Remarks on Chronic Effects on Humans:** Not available.

**Special Remarks on other Toxic Effects on Humans:**

Acute Potential:

Skin:

Lead metal granules or dust: May cause skin irritation by mechanical action.

Lead metal foil, shot or sheets: Not likely to cause skin irritation

Eyes:

Lead metal granules or dust: Can irritate eyes by mechanical action.

Lead metal foil, shot or sheets: No hazard. Will not cause eye irritation.

**Inhalation:**

In an industrial setting, exposure to lead mainly occurs from inhalation of dust or fumes.

Lead dust or fumes: Can irritate the upper respiratory tract (nose, throat) as well as the bronchi and lungs by mechanical action. Lead dust can be absorbed through the respiratory system. However, inhaled lead does not accumulate in the lungs. All of an inhaled dose is eventually absorbed or transferred to the gastrointestinal tract. Inhalation effects of exposure to fumes or dust of inorganic lead may not develop quickly. Symptoms may include metallic taste, chest pain, decreased physical fitness, fatigue, sleep disturbance, headache, irritability, reduces memory, mood and personality changes, aching bones and muscles, constipation, abdominal pains, decreasing appetite. Inhalation of large amounts may lead to ataxia, delirium, convulsions/seizures, coma, and death.

Lead metal foil, shot, or sheets: Not an inhalation hazard unless metal is heated. If metal is heated, fumes will be released. Inhalation of these fumes may cause "fume metal fever", which is characterized by flu-like symptoms. Symptoms may include metallic taste, fever, nausea, vomiting, chills, cough, weakness, chest pain, generalized muscle pain/aches, and increased white blood cell count.

**Ingestion:**

Lead metal granules or dust: The symptoms of lead poisoning include abdominal pain or cramps (lead colic), spasms, nausea, vomiting, headache, muscle weakness, hallucinations, distorted perceptions, "lead line" on the gums, metallic taste, loss of appetite, insomnia, dizziness and other symptoms similar to that of inhalation. Acute poisoning may result in high lead levels in the blood and urine, shock, coma and death in extreme cases.

Lead metal foil, shot or sheets: Not an ingestion hazard for usual industrial handling.

### Section 12: Ecological Information

**Ecotoxicity:** Not available.

**BOD5 and COD:** Not available.

**Products of Biodegradation:**

Possibly hazardous short term degradation products are not likely. However, long term degradation products may arise.

**Toxicity of the Products of Biodegradation:** The products of degradation are less toxic than the product itself.

**Special Remarks on the Products of Biodegradation:** Not available.

### Section 13: Disposal Considerations

**Waste Disposal:**

Waste must be disposed of in accordance with federal, state and local environmental control regulations.

### Section 14: Transport Information

**DOT Classification:** Not a DOT controlled material (United States).

**Identification:** Not applicable.

**Special Provisions for Transport:** Not applicable.

### Section 15: Other Regulatory Information

**Federal and State Regulations:**

California prop. 65: This product contains the following ingredients for which the State of California has found to cause cancer, birth defects or other reproductive harm, which would require a warning under the statute: Lead

California prop. 65: This product contains the following ingredients for which the State of California has found to cause reproductive harm (female) which would require a warning under the statute: Lead

California prop. 65: This product contains the following ingredients for which the State of California has found to

cause reproductive harm (male) which would require a warning under the statute: Lead  
California prop. 65 (no significant risk level): Lead: 0.0005 mg/day (value)  
California prop. 65: This product contains the following ingredients for which the State of California has found to cause birth defects which would require a warning under the statute: Lead  
California prop. 65: This product contains the following ingredients for which the State of California has found to cause cancer which would require a warning under the statute: Lead  
Connecticut hazardous material survey.: Lead  
Illinois toxic substances disclosure to employee act: Lead  
Illinois chemical safety act: Lead  
New York release reporting list: Lead  
Rhode Island RTK hazardous substances: Lead  
Pennsylvania RTK: Lead

**Other Regulations:**

OSHA: Hazardous by definition of Hazard Communication Standard (29 CFR 1910.1200).  
EINECS: This product is on the European Inventory of Existing Commercial Chemical Substances.

**Other Classifications:**

**WHMIS (Canada):** CLASS D-2A: Material causing other toxic effects (VERY TOXIC).

**DSCL (EEC):**

R20/22- Harmful by inhalation and if swallowed.  
R33- Danger of cumulative effects.  
R61- May cause harm to the unborn child.  
R62- Possible risk of impaired fertility.  
S36/37- Wear suitable protective clothing and gloves.  
S44- If you feel unwell, seek medical advice (show the label when possible).  
S53- Avoid exposure - obtain special instructions before use.

**HMIS (U.S.A.):**

**Health Hazard:** 1

**Fire Hazard:** 0

**Reactivity:** 0

**Personal Protection:** E

**National Fire Protection Association (U.S.A.):**

**Health:** 1

**Flammability:** 0

**Reactivity:** 0

**Specific hazard:**

**Protective Equipment:**

Gloves.  
Lab coat.  
Dust respirator. Be sure to use an approved/certified respirator or equivalent. Wear appropriate respirator when ventilation is inadequate.

Safety glasses.

## Section 16: Other Information

**References:** Not available.

**Other Special Considerations:** Not available.

**Created:** 10/10/2005 08:21 PM

**Last Updated:** 11/06/2008 12:00 PM

*The information above is believed to be accurate and represents the best information currently available to us. However, we make no warranty of merchantability or any other warranty, express or implied, with respect to such information, and we assume no liability resulting from its use. Users should make their own investigations to determine the suitability of the information for their particular purposes. In no event shall ScienceLab.com be liable for any claims, losses, or damages of any third party or for lost profits or any special, indirect, incidental, consequential or exemplary damages, howsoever arising, even if ScienceLab.com has been advised of the possibility of such damages.*



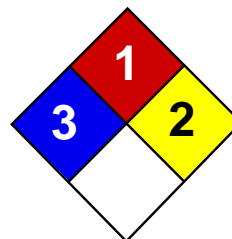

Health	3
Fire	1
Reactivity	2
Personal Protection	E

## Material Safety Data Sheet

### Arsenic MSDS

#### Section 1: Chemical Product and Company Identification

**Product Name:** Arsenic

**Catalog Codes:** SLA1006

**CAS#:** 7440-38-2

**RTECS:** CG0525000

**TSCA:** TSCA 8(b) inventory: Arsenic

**CI#:** Not applicable.

**Synonym:**

**Chemical Name:** Arsenic

**Chemical Formula:** As

**Contact Information:**

**Sciencelab.com, Inc.**

14025 Smith Rd.

Houston, Texas 77396

US Sales: **1-800-901-7247**

International Sales: **1-281-441-4400**

Order Online: [ScienceLab.com](http://ScienceLab.com)

**CHEMTREC (24HR Emergency Telephone), call:**

1-800-424-9300

**International CHEMTREC, call:** 1-703-527-3887

**For non-emergency assistance, call:** 1-281-441-4400

#### Section 2: Composition and Information on Ingredients

**Composition:**

Name	CAS #	% by Weight
Arsenic	7440-38-2	100

**Toxicological Data on Ingredients:** Arsenic: ORAL (LD50): Acute: 763 mg/kg [Rat]. 145 mg/kg [Mouse].

#### Section 3: Hazards Identification

**Potential Acute Health Effects:**

Very hazardous in case of ingestion, of inhalation. Slightly hazardous in case of skin contact (irritant), of eye contact (irritant).

**Potential Chronic Health Effects:**

**CARCINOGENIC EFFECTS:** Classified A1 (Confirmed for human.) by ACGIH. **MUTAGENIC EFFECTS:** Not available.

**TERATOGENIC EFFECTS:** Not available. **DEVELOPMENTAL TOXICITY:** Not available. The substance is toxic to kidneys, lungs, the nervous system, mucous membranes. Repeated or prolonged exposure to the substance can produce target organs damage.

#### Section 4: First Aid Measures

**Eye Contact:**

Check for and remove any contact lenses. In case of contact, immediately flush eyes with plenty of water for at least 15 minutes. Get medical attention if irritation occurs.

**Skin Contact:** Wash with soap and water. Cover the irritated skin with an emollient. Get medical attention if irritation develops.

**Serious Skin Contact:** Not available.

**Inhalation:**

If inhaled, remove to fresh air. If not breathing, give artificial respiration. If breathing is difficult, give oxygen. Get medical attention.

**Serious Inhalation:**

Evacuate the victim to a safe area as soon as possible. Loosen tight clothing such as a collar, tie, belt or waistband. If breathing is difficult, administer oxygen. If the victim is not breathing, perform mouth-to-mouth resuscitation. Seek medical attention.

**Ingestion:**

Do NOT induce vomiting unless directed to do so by medical personnel. Never give anything by mouth to an unconscious person. If large quantities of this material are swallowed, call a physician immediately. Loosen tight clothing such as a collar, tie, belt or waistband.

**Serious Ingestion:** Not available.

### Section 5: Fire and Explosion Data

**Flammability of the Product:** May be combustible at high temperature.

**Auto-Ignition Temperature:** Not available.

**Flash Points:** Not available.

**Flammable Limits:** Not available.

**Products of Combustion:** Some metallic oxides.

**Fire Hazards in Presence of Various Substances:** Flammable in presence of open flames and sparks, of heat, of oxidizing materials.

**Explosion Hazards in Presence of Various Substances:**

Risks of explosion of the product in presence of mechanical impact: Not available. Risks of explosion of the product in presence of static discharge: Not available.

**Fire Fighting Media and Instructions:**

SMALL FIRE: Use DRY chemical powder. LARGE FIRE: Use water spray, fog or foam. Do not use water jet.

**Special Remarks on Fire Hazards:**

Material in powder form, capable of creating a dust explosion. When heated to decomposition it emits highly toxic fumes.

**Special Remarks on Explosion Hazards:** Not available.

### Section 6: Accidental Release Measures

**Small Spill:** Use appropriate tools to put the spilled solid in a convenient waste disposal container.

**Large Spill:**

Use a shovel to put the material into a convenient waste disposal container. Be careful that the product is not present at a concentration level above TLV. Check TLV on the MSDS and with local authorities.

### Section 7: Handling and Storage

**Precautions:**

Keep locked up.. Keep away from heat. Keep away from sources of ignition. Empty containers pose a fire risk, evaporate the residue under a fume hood. Ground all equipment containing material. Do not ingest. Do not breathe dust. Wear suitable

protective clothing. In case of insufficient ventilation, wear suitable respiratory equipment. If ingested, seek medical advice immediately and show the container or the label. Keep away from incompatibles such as oxidizing agents, acids, moisture.

**Storage:** Keep container tightly closed. Keep container in a cool, well-ventilated area.

## Section 8: Exposure Controls/Personal Protection

### Engineering Controls:

Use process enclosures, local exhaust ventilation, or other engineering controls to keep airborne levels below recommended exposure limits. If user operations generate dust, fume or mist, use ventilation to keep exposure to airborne contaminants below the exposure limit.

**Personal Protection:** Safety glasses. Lab coat. Dust respirator. Be sure to use an approved/certified respirator or equivalent. Gloves.

### Personal Protection in Case of a Large Spill:

Splash goggles. Full suit. Dust respirator. Boots. Gloves. A self contained breathing apparatus should be used to avoid inhalation of the product. Suggested protective clothing might not be sufficient; consult a specialist BEFORE handling this product.

### Exposure Limits:

TWA: 0.01 from ACGIH (TLV) [United States] [1995] Consult local authorities for acceptable exposure limits.

## Section 9: Physical and Chemical Properties

**Physical state and appearance:** Solid. (Lustrous solid.)

**Odor:** Not available.

**Taste:** Not available.

**Molecular Weight:** 74.92 g/mole

**Color:** Silvery.

**pH (1% soln/water):** Not applicable.

**Boiling Point:** Not available.

**Melting Point:** Sublimation temperature: 615°C (1139°F)

**Critical Temperature:** Not available.

**Specific Gravity:** 5.72 (Water = 1)

**Vapor Pressure:** Not applicable.

**Vapor Density:** Not available.

**Volatility:** Not available.

**Odor Threshold:** Not available.

**Water/Oil Dist. Coeff.:** Not available.

**Ionicity (in Water):** Not available.

**Dispersion Properties:** Not available.

**Solubility:** Insoluble in cold water, hot water.

## Section 10: Stability and Reactivity Data

**Stability:** The product is stable.

**Instability Temperature:** Not available.

**Conditions of Instability:** Not available.

**Incompatibility with various substances:** Reactive with oxidizing agents, acids, moisture.

**Corrosivity:** Non-corrosive in presence of glass.

**Special Remarks on Reactivity:** Not available.

**Special Remarks on Corrosivity:** Not available.

**Polymerization:** Will not occur.

## Section 11: Toxicological Information

**Routes of Entry:** Inhalation. Ingestion.

**Toxicity to Animals:** Acute oral toxicity (LD50): 145 mg/kg [Mouse].

**Chronic Effects on Humans:**

**CARCINOGENIC EFFECTS:** Classified A1 (Confirmed for human.) by ACGIH. Causes damage to the following organs: kidneys, lungs, the nervous system, mucous membranes.

**Other Toxic Effects on Humans:**

Very hazardous in case of ingestion, of inhalation. Slightly hazardous in case of skin contact (irritant).

**Special Remarks on Toxicity to Animals:** Not available.

**Special Remarks on Chronic Effects on Humans:** Not available.

**Special Remarks on other Toxic Effects on Humans:** Not available.

## Section 12: Ecological Information

**Ecotoxicity:** Not available.

**BOD5 and COD:** Not available.

**Products of Biodegradation:**

Possibly hazardous short term degradation products are not likely. However, long term degradation products may arise.

**Toxicity of the Products of Biodegradation:** The products of degradation are as toxic as the original product.

**Special Remarks on the Products of Biodegradation:** Not available.

## Section 13: Disposal Considerations

**Waste Disposal:**

## Section 14: Transport Information

**DOT Classification:** CLASS 6.1: Poisonous material.

**Identification:** : Arsenic UNNA: UN1558 PG: II

**Special Provisions for Transport:** Not available.

## Section 15: Other Regulatory Information

**Federal and State Regulations:**

California prop. 65: This product contains the following ingredients for which the State of California has found to cause cancer, birth defects or other reproductive harm, which would require a warning under the statute: Arsenic California prop. 65: This product contains the following ingredients for which the State of California has found to cause cancer which would require a warning under the statute: Arsenic Pennsylvania RTK: Arsenic Massachusetts RTK: Arsenic TSCA 8(b) inventory: Arsenic

**Other Regulations:** OSHA: Hazardous by definition of Hazard Communication Standard (29 CFR 1910.1200).

**Other Classifications:****WHMIS (Canada):**

CLASS D-1A: Material causing immediate and serious toxic effects (VERY TOXIC). CLASS D-2A: Material causing other toxic effects (VERY TOXIC).

**DSCL (EEC):**

R22- Harmful if swallowed. R45- May cause cancer.

**HMIS (U.S.A.):**

**Health Hazard:** 3

**Fire Hazard:** 1

**Reactivity:** 2

**Personal Protection:** E

**National Fire Protection Association (U.S.A.):**

**Health:** 3

**Flammability:** 1

**Reactivity:** 2

**Specific hazard:**

**Protective Equipment:**

Gloves. Lab coat. Dust respirator. Be sure to use an approved/certified respirator or equivalent. Wear appropriate respirator when ventilation is inadequate. Safety glasses.

**Section 16: Other Information****References:**

-Hawley, G.G.. The Condensed Chemical Dictionary, 11e ed., New York N.Y., Van Nostrand Reinold, 1987. -Liste des produits purs tératogènes, mutagènes, cancérogènes. Répertoire toxicologique de la Commission de la Santé et de la Sécurité du Travail du Québec. -Material safety data sheet emitted by: la Commission de la Santé et de la Sécurité du Travail du Québec. -SAX, N.I. Dangerous Properties of Industrial Materials. Toronto, Van Nostrand Reinold, 6e ed. 1984. -The Sigma-Aldrich Library of Chemical Safety Data, Edition II. -Guide de la loi et du règlement sur le transport des marchandises dangereuses au Canada. Centre de conformité international Ltée. 1986.

**Other Special Considerations:** Not available.

**Created:** 10/09/2005 04:16 PM

**Last Updated:** 11/06/2008 12:00 PM

*The information above is believed to be accurate and represents the best information currently available to us. However, we make no warranty of merchantability or any other warranty, express or implied, with respect to such information, and we assume no liability resulting from its use. Users should make their own investigations to determine the suitability of the information for their particular purposes. In no event shall ScienceLab.com be liable for any claims, losses, or damages of any third party or for lost profits or any special, indirect, incidental, consequential or exemplary damages, howsoever arising, even if ScienceLab.com has been advised of the possibility of such damages.*

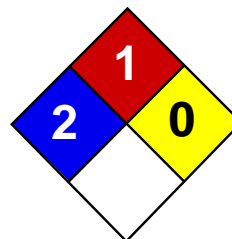

Health	2
Fire	1
Reactivity	0
Personal Protection	E

## Material Safety Data Sheet Copper MSDS

### Section 1: Chemical Product and Company Identification

**Product Name:** Copper

**Catalog Codes:** SLC4939, SLC2152, SLC3943, SLC1150, SLC2941, SLC4729, SLC1936, SLC3727, SLC5515

**CAS#:** 7440-50-8

**RTECS:** GL5325000

**TSCA:** TSCA 8(b) inventory: Copper

**CI#:** Not available.

**Synonym:**

**Chemical Name:** Not available.

**Chemical Formula:** Cu

**Contact Information:**

**Sciencelab.com, Inc.**

14025 Smith Rd.

Houston, Texas 77396

US Sales: **1-800-901-7247**

International Sales: **1-281-441-4400**

Order Online: [ScienceLab.com](http://ScienceLab.com)

**CHEMTREC (24HR Emergency Telephone), call:**

1-800-424-9300

**International CHEMTREC, call:** 1-703-527-3887

**For non-emergency assistance, call:** 1-281-441-4400

### Section 2: Composition and Information on Ingredients

**Composition:**

Name	CAS #	% by Weight
Copper	7440-50-8	100

**Toxicological Data on Ingredients:** Copper LD50: Not available. LC50: Not available.

### Section 3: Hazards Identification

**Potential Acute Health Effects:**

Very hazardous in case of ingestion. Hazardous in case of eye contact (irritant), of inhalation. Slightly hazardous in case of skin contact (irritant).

**Potential Chronic Health Effects:**

CARCINOGENIC EFFECTS: Not available. MUTAGENIC EFFECTS: Not available. TERATOGENIC EFFECTS: Not available. DEVELOPMENTAL TOXICITY: Not available. The substance is toxic to lungs, mucous membranes. Repeated or prolonged exposure to the substance can produce target organs damage.

### Section 4: First Aid Measures

**Eye Contact:** Check for and remove any contact lenses. Do not use an eye ointment. Seek medical attention.

**Skin Contact:**

After contact with skin, wash immediately with plenty of water. Gently and thoroughly wash the contaminated skin with running water and non-abrasive soap. Be particularly careful to clean folds, crevices, creases and groin. Cover the irritated skin with an emollient. If irritation persists, seek medical attention. Wash contaminated clothing before reusing.

**Serious Skin Contact:** Not available.

**Inhalation:** Allow the victim to rest in a well ventilated area. Seek immediate medical attention.

**Serious Inhalation:** Not available.

**Ingestion:**

Do not induce vomiting. Loosen tight clothing such as a collar, tie, belt or waistband. If the victim is not breathing, perform mouth-to-mouth resuscitation. Seek immediate medical attention.

**Serious Ingestion:** Not available.

### Section 5: Fire and Explosion Data

**Flammability of the Product:** May be combustible at high temperature.

**Auto-Ignition Temperature:** Not available.

**Flash Points:** Not available.

**Flammable Limits:** Not available.

**Products of Combustion:** Some metallic oxides.

**Fire Hazards in Presence of Various Substances:** Not available.

**Explosion Hazards in Presence of Various Substances:**

Risks of explosion of the product in presence of mechanical impact: Not available. Risks of explosion of the product in presence of static discharge: Not available.

**Fire Fighting Media and Instructions:**

SMALL FIRE: Use DRY chemical powder. LARGE FIRE: Use water spray, fog or foam. Do not use water jet.

**Special Remarks on Fire Hazards:** Not available.

**Special Remarks on Explosion Hazards:** Not available.

### Section 6: Accidental Release Measures

**Small Spill:**

Use appropriate tools to put the spilled solid in a convenient waste disposal container. Finish cleaning by spreading water on the contaminated surface and dispose of according to local and regional authority requirements.

**Large Spill:**

Use a shovel to put the material into a convenient waste disposal container. Finish cleaning by spreading water on the contaminated surface and allow to evacuate through the sanitary system. Be careful that the product is not present at a concentration level above TLV. Check TLV on the MSDS and with local authorities.

### Section 7: Handling and Storage

**Precautions:**

Keep away from heat. Keep away from sources of ignition. Empty containers pose a fire risk, evaporate the residue under a fume hood. Ground all equipment containing material. Do not breathe dust. Avoid contact with eyes. Wear suitable protective clothing. In case of insufficient ventilation, wear suitable respiratory equipment. If you feel unwell, seek medical attention and show the label when possible.

**Storage:**

Keep container dry. Keep in a cool place. Ground all equipment containing material. Keep container tightly closed. Keep in a cool, well-ventilated place. Combustible materials should be stored away from extreme heat and away from strong oxidizing agents.

**Section 8: Exposure Controls/Personal Protection****Engineering Controls:**

Use process enclosures, local exhaust ventilation, or other engineering controls to keep airborne levels below recommended exposure limits. If user operations generate dust, fume or mist, use ventilation to keep exposure to airborne contaminants below the exposure limit.

**Personal Protection:**

Splash goggles. Lab coat. Dust respirator. Be sure to use an approved/certified respirator or equivalent. Gloves.

**Personal Protection in Case of a Large Spill:**

Splash goggles. Full suit. Dust respirator. Boots. Gloves. A self contained breathing apparatus should be used to avoid inhalation of the product. Suggested protective clothing might not be sufficient; consult a specialist BEFORE handling this product.

**Exposure Limits:**

TWA: 1 (mg/m<sup>3</sup>) from ACGIH [1990] Consult local authorities for acceptable exposure limits.

**Section 9: Physical and Chemical Properties**

**Physical state and appearance:** Solid.

**Odor:** Not available.

**Taste:** Not available.

**Molecular Weight:** 63.54 g/mole

**Color:** Not available.

**pH (1% soln/water):** Not applicable.

**Boiling Point:** 2595°C (4703°F)

**Melting Point:** 1083°C (1981.4°F)

**Critical Temperature:** Not available.

**Specific Gravity:** 8.94 (Water = 1)

**Vapor Pressure:** Not applicable.

**Vapor Density:** Not available.

**Volatility:** Not available.

**Odor Threshold:** Not available.

**Water/Oil Dist. Coeff.:** Not available.

**Ionicity (in Water):** Not available.

**Dispersion Properties:** Not available.

**Solubility:** Insoluble in cold water.

**Section 10: Stability and Reactivity Data**



**Stability:** The product is stable.

**Instability Temperature:** Not available.

**Conditions of Instability:** Not available.

**Incompatibility with various substances:** Not available.

**Corrosivity:** Non-corrosive in presence of glass.

**Special Remarks on Reactivity:** Not available.

**Special Remarks on Corrosivity:** Not available.

**Polymerization:** No.

## Section 11: Toxicological Information

**Routes of Entry:** Absorbed through skin. Eye contact. Inhalation. Ingestion.

**Toxicity to Animals:**

LD50: Not available. LC50: Not available.

**Chronic Effects on Humans:** The substance is toxic to lungs, mucous membranes.

**Other Toxic Effects on Humans:**

Very hazardous in case of ingestion. Hazardous in case of inhalation. Slightly hazardous in case of skin contact (irritant).

**Special Remarks on Toxicity to Animals:** Not available.

**Special Remarks on Chronic Effects on Humans:** Human: passes through the placenta, excreted in maternal milk.

**Special Remarks on other Toxic Effects on Humans:** Not available.

## Section 12: Ecological Information

**Ecotoxicity:** Not available.

**BOD5 and COD:** Not available.

**Products of Biodegradation:**

Possibly hazardous short term degradation products are not likely. However, long term degradation products may arise.

**Toxicity of the Products of Biodegradation:** The products of degradation are as toxic as the original product.

**Special Remarks on the Products of Biodegradation:** Not available.

## Section 13: Disposal Considerations

**Waste Disposal:**

## Section 14: Transport Information

**DOT Classification:** Not a DOT controlled material (United States).

**Identification:** Not applicable.

**Special Provisions for Transport:** Marine Pollutant

## Section 15: Other Regulatory Information

**Federal and State Regulations:**

Pennsylvania RTK: Copper Massachusetts RTK: Copper TSCA 8(b) inventory: Copper CERCLA: Hazardous substances.: Copper

**Other Regulations:** OSHA: Hazardous by definition of Hazard Communication Standard (29 CFR 1910.1200).

**Other Classifications:**

**WHMIS (Canada):** CLASS D-2A: Material causing other toxic effects (VERY TOXIC).

**DSCL (EEC):** R36- Irritating to eyes.

**HMIS (U.S.A.):**

**Health Hazard:** 2

**Fire Hazard:** 1

**Reactivity:** 0

**Personal Protection:** E

**National Fire Protection Association (U.S.A.):**

**Health:** 2

**Flammability:** 1

**Reactivity:** 0

**Specific hazard:**

**Protective Equipment:**

Gloves. Lab coat. Dust respirator. Be sure to use an approved/certified respirator or equivalent. Wear appropriate respirator when ventilation is inadequate. Splash goggles.

**Section 16: Other Information**

**References:** Not available.

**Other Special Considerations:** Not available.

**Created:** 10/09/2005 04:58 PM

**Last Updated:** 11/06/2008 12:00 PM

*The information above is believed to be accurate and represents the best information currently available to us. However, we make no warranty of merchantability or any other warranty, express or implied, with respect to such information, and we assume no liability resulting from its use. Users should make their own investigations to determine the suitability of the information for their particular purposes. In no event shall ScienceLab.com be liable for any claims, losses, or damages of any third party or for lost profits or any special, indirect, incidental, consequential or exemplary damages, howsoever arising, even if ScienceLab.com has been advised of the possibility of such damages.*

## MATERIAL SAFETY DATA SHEET

Date Printed: 05/17/2006

Date Updated: 01/28/2006

Version 1.4

---

Section 1 - Product and Company Information

---

Product Name 10.00 G ZINC FIXANAL AS ZINC SULFATE  
Product Number 38950  
Brand RIEDEL

Company Sigma-Aldrich  
Address 3050 Spruce Street  
SAINT LOUIS MO 63103 US

Technical Phone: 800-325-5832  
Fax: 800-325-5052  
Emergency Phone: 314-776-6555

---

Section 2 - Composition/Information on Ingredient

---

Substance Name	CAS #		SARA 313
ZINC STANDARD CONCENTRATE	None		No
Ingredient Name	CAS #	Percent	SARA 313
WATER	7732-18-5	84	No
ZINC SULFATE HEPTAHYDRATE	7446-20-0	16	Yes

---

Section 3 - Hazards Identification

---

## EMERGENCY OVERVIEW

Dangerous for the environment. Harmful.  
Harmful if swallowed. Irritating to eyes and skin. Toxic to aquatic organisms, may cause long-term adverse effects in the aquatic environment.  
Target organ(s): Liver. Kidneys.

## HMIS RATING

HEALTH: 2\*  
FLAMMABILITY: 0  
REACTIVITY: 0

## NFPA RATING

HEALTH: 2  
FLAMMABILITY: 0  
REACTIVITY: 0

\*additional chronic hazards present.

For additional information on toxicity, please refer to Section 11.

---

Section 4 - First Aid Measures

---

## ORAL EXPOSURE

If swallowed, wash out mouth with water provided person is conscious. Call a physician.

## INHALATION EXPOSURE

If inhaled, remove to fresh air. If breathing becomes difficult,

call a physician.

#### DERMAL EXPOSURE

In case of contact, immediately wash skin with soap and copious amounts of water.

#### EYE EXPOSURE

In case of contact with eyes, flush with copious amounts of water for at least 15 minutes. Assure adequate flushing by separating the eyelids with fingers. Call a physician.

---

### Section 5 - Fire Fighting Measures

---

#### FLASH POINT

N/A

#### AUTOIGNITION TEMP

N/A

#### FLAMMABILITY

N/A

#### EXTINGUISHING MEDIA

Suitable: Water spray. Carbon dioxide, dry chemical powder, or appropriate foam.

#### FIREFIGHTING

Protective Equipment: Wear self-contained breathing apparatus and protective clothing to prevent contact with skin and eyes.  
Specific Hazard(s): Emits toxic fumes under fire conditions.

---

### Section 6 - Accidental Release Measures

---

#### METHODS FOR CLEANING UP

Absorb on sand or vermiculite and place in closed containers for disposal. Ventilate area and wash spill site after material pickup is complete.

---

### Section 7 - Handling and Storage

---

#### HANDLING

User Exposure: Avoid inhalation. Avoid contact with eyes, skin, and clothing. Avoid prolonged or repeated exposure.

#### STORAGE

Suitable: Keep tightly closed.

---

### Section 8 - Exposure Controls / PPE

---

#### ENGINEERING CONTROLS

Safety shower and eye bath. Mechanical exhaust required.

#### PERSONAL PROTECTIVE EQUIPMENT

Respiratory: Use respirators and components tested and approved under appropriate government standards such as NIOSH (US) or CEN (EU). Respiratory protection is not required. Where protection is desired, use multi-purpose combination (US) or type ABEK (EN 14387) respirator cartridges.

Hand: Protective gloves.

Eye: Chemical safety goggles.

#### GENERAL HYGIENE MEASURES

Wash thoroughly after handling.

---

## Section 9 - Physical/Chemical Properties

---

Appearance	Physical State: Liquid	
Property	Value	At Temperature or Pressure
pH	N/A	
BP/BP Range	N/A	
MP/MP Range	N/A	
Freezing Point	N/A	
Vapor Pressure	N/A	
Vapor Density	N/A	
Saturated Vapor Conc.	N/A	
SG/Density	N/A	
Bulk Density	N/A	
Odor Threshold	N/A	
Volatile%	N/A	
VOC Content	N/A	
Water Content	N/A	
Solvent Content	N/A	
Evaporation Rate	N/A	
Viscosity	N/A	
Surface Tension	N/A	
Partition Coefficient	N/A	
Decomposition Temp.	N/A	
Flash Point	N/A	
Explosion Limits	N/A	
Flammability	N/A	
Autoignition Temp	N/A	
Refractive Index	N/A	
Optical Rotation	N/A	
Miscellaneous Data	N/A	
Solubility	N/A	

N/A = not available

---

## Section 10 - Stability and Reactivity

---

### STABILITY

Stable: Stable.

Materials to Avoid: Strong oxidizing agents.

### HAZARDOUS DECOMPOSITION PRODUCTS

Hazardous Decomposition Products: Zinc/zinc oxides, Sulfur oxides.

### HAZARDOUS POLYMERIZATION

Hazardous Polymerization: Will not occur

---

## Section 11 - Toxicological Information

---

### ROUTE OF EXPOSURE

Skin Contact: May cause skin irritation.

Skin Absorption: May be harmful if absorbed through the skin.

Eye Contact: May cause eye irritation.

Inhalation: May be harmful if inhaled. Material may be irritating to mucous membranes and upper respiratory tract.

Ingestion: May be harmful if swallowed.

### TARGET ORGAN(S) OR SYSTEM(S)

Kidneys. Pancreas. Liver. Lungs.

#### SIGNS AND SYMPTOMS OF EXPOSURE

To the best of our knowledge, the chemical, physical, and toxicological properties have not been thoroughly investigated.

---

#### Section 12 - Ecological Information

---

No data available.

---

#### Section 13 - Disposal Considerations

---

#### APPROPRIATE METHOD OF DISPOSAL OF SUBSTANCE OR PREPARATION

Contact a licensed professional waste disposal service to dispose of this material. Dissolve or mix the material with a combustible solvent and burn in a chemical incinerator equipped with an afterburner and scrubber. Observe all federal, state, and local environmental regulations.

---

#### Section 14 - Transport Information

---

#### DOT

Proper Shipping Name: Environmentally hazardous substances, liquid, n.o.s.  
UN#: 3082  
Class: 9  
Packing Group: Packing Group III  
Hazard Label: Class 9  
PIH: Not PIH

#### IATA

Proper Shipping Name: Environmentally hazardous substance, liquid, n.o.s.  
IATA UN Number: 3082  
Hazard Class: 9  
Packing Group: III

---

#### Section 15 - Regulatory Information

---

#### EU ADDITIONAL CLASSIFICATION

Symbol of Danger: Xi-N  
Indication of Danger: Irritant. Dangerous for the environment.  
R: 41-50/53  
Risk Statements: Risk of serious damage to eyes. Very toxic to aquatic organisms, may cause long-term adverse effects in the aquatic environment.  
S: 26-39-61  
Safety Statements: In case of contact with eyes, rinse immediately with plenty of water and seek medical advice. Wear eye/face protection. Avoid release to the environment. Refer to special instructions/safety data sheets.

#### US CLASSIFICATION AND LABEL TEXT

Indication of Danger: Dangerous for the environment. Harmful.  
Risk Statements: Harmful if swallowed. Irritating to eyes and skin. Toxic to aquatic organisms, may cause long-term adverse effects in the aquatic environment.  
Safety Statements: Avoid contact with eyes. Wear suitable protective clothing. Avoid release to the environment. Refer to special instructions/safety data sheets.  
US Statements: Target organ(s): Liver. Kidneys.

#### UNITED STATES REGULATORY INFORMATION

SARA LISTED: No

CANADA REGULATORY INFORMATION

WHMIS Classification: This product has been classified in accordance with the hazard criteria of the CPR, and the MSDS contains all the information required by the CPR.

DSL: No

NDSL: No

---

Section 16 - Other Information

---

DISCLAIMER

For R&D use only. Not for drug, household or other uses.

WARRANTY

The above information is believed to be correct but does not purport to be all inclusive and shall be used only as a guide. The information in this document is based on the present state of our knowledge and is applicable to the product with regard to appropriate safety precautions. It does not represent any guarantee of the properties of the product. Sigma-Aldrich Inc., shall not be held liable for any damage resulting from handling or from contact with the above product. See reverse side of invoice or packing slip for additional terms and conditions of sale. Copyright 2006 Sigma-Aldrich Co. License granted to make unlimited paper copies for internal use only.

**Site-Specific Health and Safety Plan  
The Peninsula Redevelopment Project  
1221 Spofford Avenue, Bronx, New York**

---

**APPENDIX C**

Personal Protective Equipment (PPE) Management Program



## PERSONAL PROTECTIVE EQUIPMENT MANAGEMENT PROGRAM

**CORPORATE HEALTH AND SAFETY MANAGER** : **Brian Hobbs, CIH, CSP**  
**EFFECTIVE DATE** : **01/19**  
**REVISION NUMBER** : **4**

**TABLE OF CONTENTS**

1. PURPOSE.....	1
2. SCOPE AND APPLICABILITY.....	1
3. PROCEDURES.....	1
3.1 Introduction.....	1
3.2 Types of PPE.....	1
3.3 Protective Clothing Selection Criteria.....	2
3.3.1 Chemicals Present.....	2
3.3.2 Concentration of the Chemical(s).....	2
3.3.3 Physical State.....	3
3.3.4 Length of Exposure.....	3
3.3.5 Abrasion.....	3
3.3.6 Dexterity.....	3
3.3.7 Ability to Decontaminate.....	3
3.3.8 Climactic Conditions.....	3
3.3.9 Work Load.....	4
3.4 Types of Protective Materials.....	4
3.5 Protection Levels.....	4
3.5.1 Level A Protection.....	4
3.5.2 Level B Protection.....	5
3.5.3 Level C Protection.....	6
3.5.4 Level D Protection.....	6
3.5.5 Level E Protection.....	6
3.5.6 Additional Considerations.....	7

## **1. PURPOSE**

Roux Associates, Inc. and its affiliated companies, Roux Environmental Engineering and Geology, D.P.C, and Remedial Engineering (collectively, "Roux") has instituted the following program to establish guidelines for the selection of personal protective equipment (PPE) for use by Roux personnel performing field activities in hazardous environments. PPE is not meant to be a substitute for engineering, work practice, and/or administrative controls, but PPE should be used in conjunction with these controls to protect the employees in the work place. Clothing, body coverings, and other accessories designed to prevent worker exposure to workplace hazards are all types of PPE. To ensure adequate PPE employee-owned PPE is evaluated on a case-by-case basis to insure its adequacy, maintenance and sanitation.

## **2. SCOPE AND APPLICABILITY**

These guidelines apply to all PPE selection decisions to be made in implementing the Roux program. The foundations for this program are the numerous Occupational Health and Safety Administration (OSHA) standards related to PPE cited in 29 CFR 1910 Subpart I, 29 CFR 1926 Subpart E, and the hazardous environment work employee protection requirements under the OSHA Hazardous Waste Operations and Emergency Response (HAZWOPER) standard at 29 CFR 1910.120 and 1926.65. To ensure hazard assessments are documented the levels of protection, types of protection and tasks requiring protection are covered in site-specific Health and Safety Plans (HASPs) and Job Safety Analyses (JSAs).

## **3. PROCEDURES**

Due to the varied nature of site activities and the different potential hazards associated with different sites, several aspects must be considered when selecting PPE. The following text describes PPE selection logic and provides guidelines and requirements for the appropriate selection and use of PPE.

### **3.1 Introduction**

To harm the body, chemicals must first gain entrance. The intact skin and the respiratory tract are usually the first body tissues attacked by chemical contaminants. These tissues provide barriers to some chemicals but in many cases, are damaged themselves or are highly permeable by certain chemical compounds. Personal protective equipment therefore is used to minimize or eliminate chemical compounds coming into contact with these first barrier tissues.

The proper selection of equipment is important in preventing exposures. The PM making the selection will have to take several factors into consideration. The level of protection, type and kind of equipment selected depends on the hazardous conditions and in some cases cost, availability, compatibility with other equipment, and performance. An accurate assessment of all these factors must be made before work can be safely carried out.

### **3.2 Types of PPE**

The type and selection of PPE must meet certain general criteria and requirements as required under OSHA 29 CFR 1910.132 and 1926.95. In addition to these general requirements, specific requirements and specifications exist for some types of PPE that form the basis of the protective clothing scheme. Following is a list of the common types of specific PPE and the specific requirements for the PPE type, where applicable:

1. Hard Hats - Regulated by 29 CFR 1910.135 and 1926.100; and, specified in ANSI Z89.1.

2. Face Shields and Safety Glasses - Regulated by 29 CFR 1910.133 and 1926.102; and, specified in ANSI Z87.1.
3. Respiratory Protection - Regulated by 29 CFR 1910.134 and 1926.103.
4. Hand Protection - Not specifically regulated.
5. Foot Protection - Regulated by 29 CFR 1910.136 and 1926.96; and, specified in ANSI Z41.1.
6. Protective Clothing (e.g., fully encapsulated suits, aprons) - Not specifically regulated.

### **3.3 Protective Clothing Selection Criteria**

#### **3.3.1 Chemicals Present**

The most important factor in selecting PPE is the determination of what chemicals the employee may be exposed to. On field investigations, the number of chemicals may range from a few to several hundred. The exact chemicals or group of chemicals present at the site (certain groups tend to require similar protection) can be determined by collecting and analyzing samples of the air, soil, water, or other site media. When data are lacking, research into the materials used or stored at the site can be used to infer chemicals possibly on the site.

Once the known or suspected chemicals have been identified, and taking into consideration the type of work to be performed, the most appropriate clothing shall be selected.

Protective garments are made of several different substances for protection against specific chemicals. There is no universal protective material. All will decompose, be permeated by, or otherwise fail to protect under given circumstances. Fortunately, most manufacturers make guides to the use of their products (i.e., Dupont's Tyvek™ Permeation Guide). These guides are usually for gloves and coveralls and typically provide information regarding chemical degradation rates (failure of the material to maintain structural integrity when in contact with the chemical), and may provide information on the permeation rate (whether or not the material allows the chemical to pass through). When permeation tables are available, they shall be used in conjunction with degradation tables to determine the most appropriate protective material.

During most site work, chemicals are usually in mixed combinations and the protective materials are not in continuous contact with pure chemicals for long periods of time; therefore, the selected material may be adequate for the particular chemical and type of work being performed, yet not the "best" protecting material for all site chemicals and activities. Selection shall depend upon the most hazardous chemicals based on their hazards and concentrations. Sometimes layering, using several different layers of protective materials, affords the best protection.

#### **3.3.2 Concentration of the Chemical(s)**

One of the major criteria for selecting protective material is the concentration of the chemical(s) in air, liquid, and/or solid state. Airborne and liquid chemical concentrations should be compared to the OSHA standards and/or American Conference of Governmental Industrial Hygienists (ACGIH) and National Institute for Occupational Safety and Health (NIOSH) guidelines to determine the level of skin or other absorptive surface (e.g., eyes) protection needed. While these standards are not designed specifically for skin exposed directly to the liquid, they may provide skin designations indicative of chemicals known to have significant skin or dermal absorption effects. For example, airborne levels of PCB on-site may be

low because it is not very volatile, so the inhalation hazard may be minimal; however, PCB-containing liquid coming in direct contact with the skin may cause overexposure. Thus, PCB has been assigned a skin designation in both the OSHA and ACGIH exposure limit tables.

### **3.3.3 Physical State**

The characteristics of a chemical may range from nontoxic to extremely toxic depending on its physical state. Inorganic lead in soil would not be considered toxic to site personnel, unless it became airborne, since it is generally not absorbed through the intact skin. Organic lead in a liquid could be readily absorbed. Soil is frequently contaminated with hazardous materials. Concentrations will vary from a few parts per million to nearly one hundred percent. The degree of hazard is dependent on the type of soil and concentration of the chemical. Generally speaking, "dry" soils do not cause a hazard to site personnel if they take minimal precautions such as wearing some type of lightweight gloves.

### **3.3.4 Length of Exposure**

The length of time a material is exposed to a chemical increases the probability of breakthrough. Determinations of actual breakthrough times for short-term exposures indicate that several different materials can be used which would be considered inadequate under long-term exposures. It should be kept in mind that during testing, a pure (100% composition) liquid is usually placed in direct contact with the material producing a worst-case situation.

### **3.3.5 Abrasion**

When selecting protective clothing, the job the employee is engaged in must be taken into consideration. Persons moving drums or performing other manual tasks may require added protection for their hands, lower chest and thighs. The use of leather gloves and a heavy apron over the other normal protective clothing will help prevent damage to the normal PPE and thus reduce worker exposures.

### **3.3.6 Dexterity**

Although protection from skin and inhalation hazards is the primary concern when selecting PPE, the ability to perform the assigned task must be maintained. For example, personnel cannot be expected to perform work that requires fine dexterity if they must wear a thick glove. Therefore, the PPE selection process must consider the task being performed and provide PPE alternatives or techniques that allow dexterity to be maintained while still protecting the worker (e.g., wearing tight latex gloves over more bulky hand protection to increase dexterity).

### **3.3.7 Ability to Decontaminate**

If disposable clothing cannot be used, the ability to decontaminate the materials selected must be taken into consideration. Once a chemical contacts the material, it must be cleaned before it can be reused. If the chemical has completely permeated the material, it is unlikely that the clothing can be adequately decontaminated and the material should be discarded.

### **3.3.8 Climactic Conditions**

The human body works best with few restraints from clothing. Protective clothing adds a burden by adding weight and restricting movement as well as preventing the natural cooling process. In severe situations, a modified work program must be used.

Some materials act differently when they are very hot and very cold. For example, PVC becomes almost brittle in very cold temperatures. If there are any questions about the stability of the protective materials under different conditions, the manufacturer should be contacted.

### **3.3.9 Work Load**

Like climactic conditions, the type of work activity may affect work duration and the ability of personnel to perform certain tasks. Similarly, the amount of protective materials a person wears will affect their ability to perform certain tasks. For example, a person in a total encapsulating suit, even at 72 °F, cannot work for more than a short period of time without requiring a break.

The work schedule should be adjusted to maintain the health of the employees. Special consideration should be given to the selection of clothing that both protects and adds the least burden when personnel are required to perform strenuous tasks. Excessive bodily stress frequently represents the most significant hazard encountered during field work.

## **3.4 Types of Protective Materials**

1. Cellulose or Paper
2. Natural and Synthetic Fibers
  - a. Tyvek™
  - b. Nomex™
3. Elastomers
  - a. Polyethylene
  - b. Saran
  - c. Polyvinyl Chloride (PVC)
  - d. Neoprene
  - e. Butyl Rubber
  - f. Viton

## **3.5 Protection Levels**

### **3.5.1 Level A Protection**

Level A protection (a fully encapsulated suit) is used when skin hazards exist or when there is no known data that positively rule out skin and other absorption hazards. Since Level A protection is extremely physiologically and psychologically stressful, the decision to use this protection must be carefully considered. At no time will Level A work be performed without the consent of the OM. The following conditions suggest a need for Level A protection:

- confined facilities where probability of skin contact is high;
- sites containing known skin hazards;
- sites with no established history to rule out skin and other absorption hazards;
- atmosphere immediately dangerous to life and health (IDLH) through the skin absorption route;
- site exhibiting signs of acute mammalian toxicity (e.g., dead animals, illnesses associated with past entry into site by humans);

- sites at which sealed drums of unknown materials must be opened;
- total atmospheric readings on the Photoionization Detector (PID), Flame Ionization Detector (FID), and similar instruments indicate 500 to 1,000 ppm of unidentified substances; and
- extremely hazardous substances (e.g., cyanide compounds, concentrated pesticides, Department of Transportation Poison "A" materials, suspected carcinogens and infectious substances) are known or suspected to be present and skin contact is possible.

The following items constitute Level A protection:

- open circuit, pressure-demand self-contained breathing apparatus (SCBA);
- totally encapsulated suit;
- gloves, inner (surgical type);
- gloves, outer;
- chemical protective;
- boots, chemical protective, steel toe and shank;
- radiation detector (if applicable); and
- communications.

### **3.5.2 Level B Protection**

Level B protection is utilized when the highest level of respiratory protection is needed but hazardous material exposure to the few unprotected areas of the body is unlikely.

The following conditions suggest a need for Level B protection:

- the type and atmospheric concentration of toxic substances have been identified and they require the highest level of respiratory protection;
- IDLH atmospheres where the substance or concentration in the air does not present a severe skin hazard;
- the type and concentrations of toxic substances do not meet the selection criteria permitting the use of air purifying respirators; and
- it is highly unlikely that the work being done will generate high concentrations of vapors, gases or particulates, or splashes of materials that will affect the skin of personnel.

Personal protective equipment for Level B includes:

- open circuit, pressure-demand SCBA;
- chemical protective clothing:
- overalls and long-sleeve jacket; or
- coveralls;
- gloves, inner (surgical type); gloves, outer, chemical protective;
- boots, chemical protective, steel toe and shank; and
- communications optional.

### **3.5.3 Level C Protection**

Level C protection is utilized when both skin and respiratory hazards are well defined and the criteria for the use of negative pressure respirators have been fulfilled (i.e., known contaminants and contaminant concentrations, acceptable oxygen levels, approved filter/cartridge available, known cartridge service life, etc.). Level C protection may require carrying an emergency escape respirator during certain initial entry and site reconnaissance situations, or when applicable thereafter.

Personal protective equipment for Level C typically includes:

- full facepiece air-purifying respirator;
- emergency escape respirator (optional);
- chemical protective clothing:
  - overalls and long-sleeved jacket; or
  - coveralls;
- gloves, inner (surgical type);
- gloves, outer, chemical protective; and
- boots, chemical protective, steel toe and shank.

### **3.5.4 Level D Protection**

Level D is the basic work uniform. Personal protective equipment for Level D includes:

- coveralls;
- safety boots/shoes;
- eye protection;
- hand protection;
- reflective traffic safety vest (mandatory for traffic areas or railyard);
- hard hat (with face shield is optional); and
- emergency escape respirator is optional.

### **3.5.5 Level E Protection**

Level E protection is used when radioactivity above 10 mr/hr is detected at the site. Personal protective equipment for Level E includes:

- coveralls;
- air purifying respirator;
- time limits on exposure;
- appropriate dermal protection for the type of radiation present; and
- radiation dosage monitoring.



### 3.5.6 Additional Considerations

Field work will contain a variety of situations due to chemicals in various concentrations and combinations. These situations may be partially ameliorated by following the work practices listed below:

1. Some sort of foot protection is needed on a site. If the ground to be worked on is contaminated with liquid and it is necessary to walk in the chemicals, some sort of protective "booties" can be worn over the boots. This cuts down on decontamination requirements. They are designed with soles to help prevent them from slipping around. If non-liquids are to be encountered, a Tyvek™ bootie could be used. If the ground contains any sharp objects, the advantage of booties is questionable. Boots should be worn with either cotton or wool socks to help absorb the perspiration.
2. If the site situation requires the use of hard hats, chin straps should be used if a person will be stooping over where his/her hat may fall off. Respirator straps should not be placed over the hard hats. This will affect the fit of the respirator.

Some types of protective materials conduct heat and cold readily. In cold conditions, natural material clothing should be worn under the protective clothing. Protective clothing should be removed prior to allowing a person "to get warm". Applying heat, such as a space heater, to the outside of the protective clothing may drive the contaminants through. In hot weather, under clothing will absorb sweat. It is recommended that workers use all cotton undergarments.

3. Body protection should be worn and taped to prevent anything from running into the top of the boot. Gloves should be worn and taped to prevent substances from entering the top of the glove. Duct tape is preferred, but masking tape can be used. When aprons are used, they should be taped across the back for added protection. However, this should be done in such a way that the person has mobility.
4. Atmospheric conditions such as precipitation, temperature, wind direction, wind velocity, and pressure determine the behavior of contaminants in air or the potential for volatile material getting into the air. These parameters should be considered in determining the need for and the level of protection.
5. A program must be established for periodic monitoring of the air during site operations. Without an air monitoring program, any changes would go undetected and might jeopardize response personnel. Monitoring can be done with various types of air pumps and filtering devices followed by analysis of the filtration media; personnel dosimeters; and periodic walk-throughs by personnel carrying real-time survey instruments.
6. For operations in the exclusion zone, different levels of protection may be selected, and various types of chemical-resistant clothing may be worn. This selection should be based on the job function, reason for being in the area, and the potential for skin contact with, or inhalation of, the chemicals present.
7. Escape masks must be readily available when levels of respiratory protection do not include a SCBA and the possibility of an IDLH atmosphere exists. Their use can be made on a case-by-case basis. Escape masks could be strategically located at the site in areas that have higher possibilities of vapors, gases or particulates.

**Site-Specific Health and Safety Plan**  
***The Peninsula Redevelopment Project***  
***1221 Spofford Avenue, Bronx, New York***

---

**APPENDIX D**

Subsurface Utility Clearance Management Program

## SUBSURFACE UTILITY CLEARANCE MANAGEMENT PROGRAM

**CORPORATE HEALTH AND SAFETY MANAGER** : **Brian Hobbs, CIH, CSP**  
**EFFECTIVE DATE** : **07/18**  
**REVISION NUMBER** : **1**

**TABLE OF CONTENTS**

1. PURPOSE ..... 1

2. SCOPE AND APPLICABILITY ..... 1

3. PROCEDURES ..... 1

    3.1 Before Intrusive Activities ..... 1

    3.2 During Intrusive Activities ..... 2

    3.3 Stop Work Authority ..... 3

Appendix A - Definitions ..... 4

Appendix B - Example of Completed One Call Report ..... 5

Appendix C - Roux Subsurface Utility Clearance Checklist ..... 6

Appendix D - Utility Verification/Site Walkthrough Record ..... 8

**APPENDICES**

- Appendix A – Definitions
- Appendix B – Example of Completed One Call
- Appendix C – Roux Subsurface Utility Clearance Checklist
- Appendix D – Utility Verification/Site Walkthrough Record

## 1. PURPOSE

Roux Associates, Inc. and its affiliated companies, Roux Environmental Engineering and Geology, D.P.C., and Remedial Engineering (collectively, "Roux") has instituted the following program for completing proper utility mark-outs and for conducting subsurface clearance activities. This establishes a method to ensure, to the greatest extent possible, that utilities have been identified and contact and/or damage to underground utilities and other subsurface structures will be avoided.

## 2. SCOPE AND APPLICABILITY

The Subsurface Utility Clearance Management Program applies to all Roux employees, its contractors and subcontractors. Employees are expected to follow this program for all intrusive work involving Roux or other personnel (e.g., contractors/subcontractors) working for Roux unless the client's requirements are more stringent. Deviation from the program regardless of the specific work activity or work location must be pre-approved based on client's site knowledge, site experience and client's willingness for the use of this program. Any and all exceptions shall be documented and pre-approved by the Project Principal and the Office Manager.

## 3. PROCEDURES

### 3.1 Before Intrusive Activities

During the project kick-off meeting for intrusive activities the PM will review the Roux Subsurface Utility Clearance Checklist and Utility Verification (Appendix C) / Site Walkthrough Record (Appendix D) and the below bullet points with the project field team:

(Please note that these are intended as general reminders only and should not be solely relied upon.)

- Ensure the Mark-out / Stake-out Request Information Sheet (or one-call report) is complete and accurate for the site including address and cross streets and review for missing utilities. (Note: utility mark-out organizations do not have contracts with all utilities and it is often necessary to contact certain utilities separately such as the local water and sewer authorities).
- Have written confirmation prior to mobilizing to the site that the firm or Roux personnel performing the intrusive activity has correctly completed the mark-out notification process including requesting mark-outs, waiting for mark-outs to be applied to ground surfaces at the site, and receiving written confirmation of findings (via fax or email) from utility operators for all known or suspected utilities in the proposed area of intrusive activity, and provided utility owner written confirmation to Roux personnel for review and project files documentation.
- Do not begin any intrusive activity until all utilities mark-out has been completed (i.e., did all utilities mark-out the site?) and any unresolved mark-out issues are finalized. Perform a site walk to review the existing utilities and determine if said utilities have been located by the utility locators.

(Note: The Tolerance Zone is defined as two feet plus half of the diameter or half of the greatest dimension (for elliptical sewers, duct banks and other non-cylindrical utilities) of a utility and two feet from the outside edge of any subsurface structure.)

- Install Pre-Clearance exploratory test holes (e.g., hand-dug test holes or other soft digging techniques) for the first 5-ft below land surface (BLS) at each location prior to conducting mechanized intrusive activities. The size of the pre-clearance exploratory test hole should be at a minimum twice the diameter of any downhole tool or boring device. (Note: Pre-Clearance exploratory test holes should be defined in the SOW/proposal provided to the client to prevent project delays and to allow adequate time for PM and PP to evaluate alternative approaches for the project. Alternative approaches will need to be pre-approved by the OM.

- For excavations, all utilities need to be marked and then exposed by hand following the protocols in this program. Pre-clearing for excavations may be performed by the “moat” technique (i.e., soft digging around the perimeter). In these cases, dig in small lifts (<12” for first 5 feet) using a dedicated spotter.) For Tolerance Zone work, unless otherwise agreed upon with the Utility Operator, work within the tolerance zone requires verification by means of hand-dug test holes performed to expose the utility. Once structures have been verified a minimum clearance of two feet must be maintained between the utility and any powered equipment.
- In addition, the following activities should be conducted:
  - Review the work scope to be performed with the site owner/tenant to determine if it may impact any utilities;
  - Attempt to procure any utility maps or historic drawings of subsurface conditions of the site;
  - **Determine the need for utility owner companies to be contacted or to have their representatives on site;**
  - Where mark-outs terminate at the property boundary, consider the use of private utility locating / GPR / geophysical-type services which may be helpful in locating utilities. Use of private utility locating firms, however, does not eliminate the legal requirement for the Excavator firm to submit a request for Public Utility Mark-outs. Also, the information provided by the service may be inaccurate and unable to locate subsurface utilities and structures in urban areas, landfills, urban fill areas and below reinforced slabs, etc. They should not be relied upon as the only means of performing utility clearance;
  - Documented description of the dig site which is included in the projects Health and Safety Plan (HASP) and one call report will be maintained in the field and distributed amongst Roux personnel its contractors and subcontractors; and
  - Documentation of the actual placement of mark outs in the field shall be collected using dated pictures, videos and/or sketches with distance from markings to fixed objects. All documentation shall be maintained within the project file.

### **3.2 During Intrusive Activities**

The PM, field team lead or personnel performing oversight is to:

- Ensure the mark-out remains valid. (In certain states there are limits regarding the duration of time after the mark-out was applied to the ground surface work can be started or interrupted.) Additionally, the mark-outs must be maintained, documented, and in many cases refreshed periodically to be considered valid, this will be accomplished through calls to the one call center.
- Ensure intrusive activities are only performed within the safe boundaries of the mark-out as detailed in the One-Call Report.
- Halt all work if intrusive activities have resulted in discovery of an unmarked utility. Roux personnel shall notify the facility owner/operator and the one call center. All incidents such as this will be reported as per Roux Incident Investigation and Reporting Management Program.
- Halt all work if intrusive activities must take place outside of the safe boundaries of a mark-out and only proceed after new mark-outs are performed.
- Halt the intrusive activities and immediately consult with the PP if an unmarked utility is encountered.
- Completing any subsurface utility clearance incident reports that are necessary.

- If a utility cannot be found as marked Roux personnel shall notify the facility owner/operator directly or through the one call center. Following notification, the excavation may continue, unless otherwise specified in state law.
- Contractors/subcontractors must contact the one-call center to refresh the ticket when the excavation continues past the life of the ticket. Ticket life shall be dictated by state law however at a maximum ticket life shall not exceed 20 working days.

### **3.3 Stop Work Authority**

Each Roux employee has Stop Work Authority which he or she will execute upon determination of any imminent safety hazard, emergency situation, or other potentially dangerous situation, such as hazardous weather conditions. This Stop Work Authority includes subsurface clearance issues such as the adequacy of a mark-out or identification during intrusive operations of an unexpected underground utility. Authorization to proceed with work will be issued by the PM/PP after such action is reviewed and resolved. The PM will initiate and execute all management notifications and contact with emergency facilities and personnel when this action is appropriate.

**Appendix A - Definitions**

<b><i>Intrusive Work Activities</i></b>	All activities such as digging or scraping the surface, including but not limited to, excavation, test pitting or trenching, soil vapor sampling or the installation of soil borings, soil vapor monitoring points and wells, or monitoring wells, and drilling within the basement slab of a recently demolished building.
<b><i>Mark-out / Stake Out</i></b>	The process of contracting with a competent and qualified company to confirm the presence or absence of underground utilities and structures. This process will clearly mark-out and delineate utilities that are identified so that intrusive work activities can be performed without causing disturbance or damage to the subsurface utilities and structures. After utility mark-outs are completed the soft digging will be completed prior to intrusive work.
<b><i>Tolerance Zone</i></b>	Defined as two feet on either side of the designated centerline of an identified utility, plus half of the diameter or half of the greatest dimension (for elliptical sewers, duct backs and other non-cylindrical utilities) of that utility and two feet from the outside edge of any subsurface structure.
<b><i>Structure</i></b>	For the purpose of this program a structure is defined as any underground feature that may a present potential source(s) of energy such as, but not limited to, utility vaults, bunkers, piping, electrical boxes, wires, conduits, culverts, utility lines, underground tanks and ducts.
<b><i>Soft Digging</i></b>	The safest way to remove material from unknown obstructions or services is by using tools such as a vactor or air knife, non-mechanical tools, or hand tools. The methods are clean and non-evasive and used for uncovering and exposing buried services, excavating and for providing a quick method of soil removal from sensitive areas.
<b><i>Verification</i></b>	Exploratory test-hole dug with hand tools within the Tolerance Zone to expose and verify the location, type, size, direction-of-run and depth of a utility or subsurface structure. Vacuum excavation (soft dig) methods can further facilitate exposure of a subsurface utility and accurately provide its location and identification prior to intrusive work approaching the Tolerance Zone.





---

**Appendix B - Example of Completed One Call Report**

***Example Completed One-Call Report***

New York 811

Send To: C\_EMAIL    Seq No: 744

Ticket No: 133451007    ROUTINE

Start Date: 12/16/13    Time: 7:00 AM    Lead Time: 20

State: NY    County: QUEENS    Place: QUEENS

Dig Street: 46TH AVE    Address:

Nearest Intersecting Street: VERNON BLVD

Second Intersecting Street: 11TH ST

Type of Work: SOIL BORINGS

Type of Equipment: GEOPROBE

Work Being Done For: ROUX

In Street: X    On Sidewalk: X    Private Property:    Other:

On Property Location if Private:    Front:    Rear:    Side:

Location of Work: MARK THE ENTIRE NORTH SIDE OF THE STREET AND SIDEWALK OF:  
46TH AVE BETWEEN VERNON BLVD AND 11TH STREET

Remarks:

Nad:    Lat:    Lon:    Zone:

ExCoord NW Lat: 40.7475399 Lon: -73.9534811 SE Lat: 40.7457406 Lon: -73.9493680

Company : ZEBRA ENVIROMENTAL    Best Time: 6AM-5PM

Contact Name: DAVID VINES    Phone: (516)596-6300

Field Contact: DAVID VINES    Phone: (516)596-6300

Caller Address: 30 N PROSPECT AVE    Fax Phone: (516)596-4422

LYNBROOK, NY 11563

Email Address: [david@zebraenv.com](mailto:david@zebraenv.com)

Additional Operators Notified:

ATTNY01    AT&T CORPORATION    (903)753-3145

CEQ    CONSOLIDATED EDISON CO. OF N.Y    (800)778-9140

MCINY01    MCI    (800)289-3427

PANYNJ01    PORT AUTHORITY OF NY & NJ    (201)595-4841

VZQ    VERIZON COMMUNICATIONS    (516)297-1602

Link to Map for C\_EMAIL: <http://ny.itic.occinc.com/XGMZ-DF2-L23-YAY>

Original Call Date: 12/11/13    Time: 1:15 PM    Op: webusr

IMPORTANT NOTE: YOU MUST CONTACT ANY OTHER UTILITIES DIRECTLY

**Appendix C - Roux Subsurface Utility Clearance Checklist**

**Roux Subsurface Utility Clearance Checklist**

**Date of Revision –  
12/3/14**

**Work site set-up and work execution**

ACTIVITY	Yes	No	N/A	COMMENTS INCLUDING JUSTIFICATION IF RESPONSE IS NO OR NOT APPLICABLE
Daily site safety meeting conducted, SPSAs performed, JSAs reviewed, appropriate work permits obtained.				
HASP is available and reviewed by site workers / visitors.				
Subsurface Utility Clearance Procedure has been reviewed with all site workers.				
Work area secured; traffic control established as needed. Emergency shut-off switch located. Fire extinguishers / other safety equipment available as needed.				
Utility mark-outs (public / private) clear and visible. Provide Excavator's Stake-Out Reference Number / Request Date / Time.				
Tolerance zone work identified.				
Work execution plan reviewed and adhered to (ground disturbance methods, clearance depths, any special utility protection requirements, or any other execution requirements; especially for Tolerance Zone work).				
Verbal endorsement received from Roux PM for any required field deviations to work execution plan.				

**Key reminders for execution:**

The Subsurface Utility Clearance Protocol should be referenced to determine all requirements while executing subsurface work. The bullet points below are intended as general reminders only and should not be solely relied upon.

- Tolerance zone is defined as two feet plus half of the diameter or half of the greatest dimension (for elliptical sewers, duct banks and other non-cylindrical utilities) of a utility and two feet from the outside of any subsurface structure.
- Install Pre-Clearance exploratory test holes (e.g., hand-dug test holes or vacuum excavation) must be performed for the first five feet below land surface (BLS) at each location prior to conducting mechanized intrusive activities. The size of the pre-clearance exploratory test hole should be at a minimum twice the diameter of any downhole tool or boring device. (Note: Pre-clearance exploratory test holes should be defined in the SOW/proposal provided to the client to prevent project delays and to allow adequate time for PM and PP to evaluate alternative approaches for the project. Alternate approaches will need to be pre-approved by the OM.
- For excavations, all utilities need to be marked and then exposed by hand following the protocols in this program. Pre-clearing for excavations may be performed by the "moat" technique (i.e., soft

digging around the perimeter). In these cases, dig in small lifts (<12" for first five feet) using a dedicated spotter.) For Tolerance Zone work, unless otherwise agreed upon with the Utility Operator, work within the tolerance zone requires verification by means of hand-dug test holes to expose the utility. Once structures have been verified a minimum clearance of two feet must be maintained between the utility and any powered equipment.

**Appendix D - Utility Verification/Site Walkthrough Record**

**Employee Name:** \_\_\_\_\_

**Date:** \_\_\_\_\_

**Instructions:** For each utility suspected at the job site, indicate location on the job site, approximate burial depth, and means of detecting the utility. Leave blank if that utility is not believed to be present.

Utility	Description of Utility Location Identified Onsite	Approx. Depth (bls)	Method / Instrumentation used to determine Utility Location	Utility Owner Response (Date/Time)	Mark Out Indicates (Clear / Conflict)
Electrical Lines					
Gas Lines					
Pipelines					
Steam Lines					
Water Lines					
Sanitary and Stormwater Sewer lines					
Pressured Air-Lines					
Tank Vent Lines					
Fiber Optic Lines					
Underground Storage Tanks					
Phone Lines/ Other					

\* bls - below land surface

Site Sketch Showing Utilities:

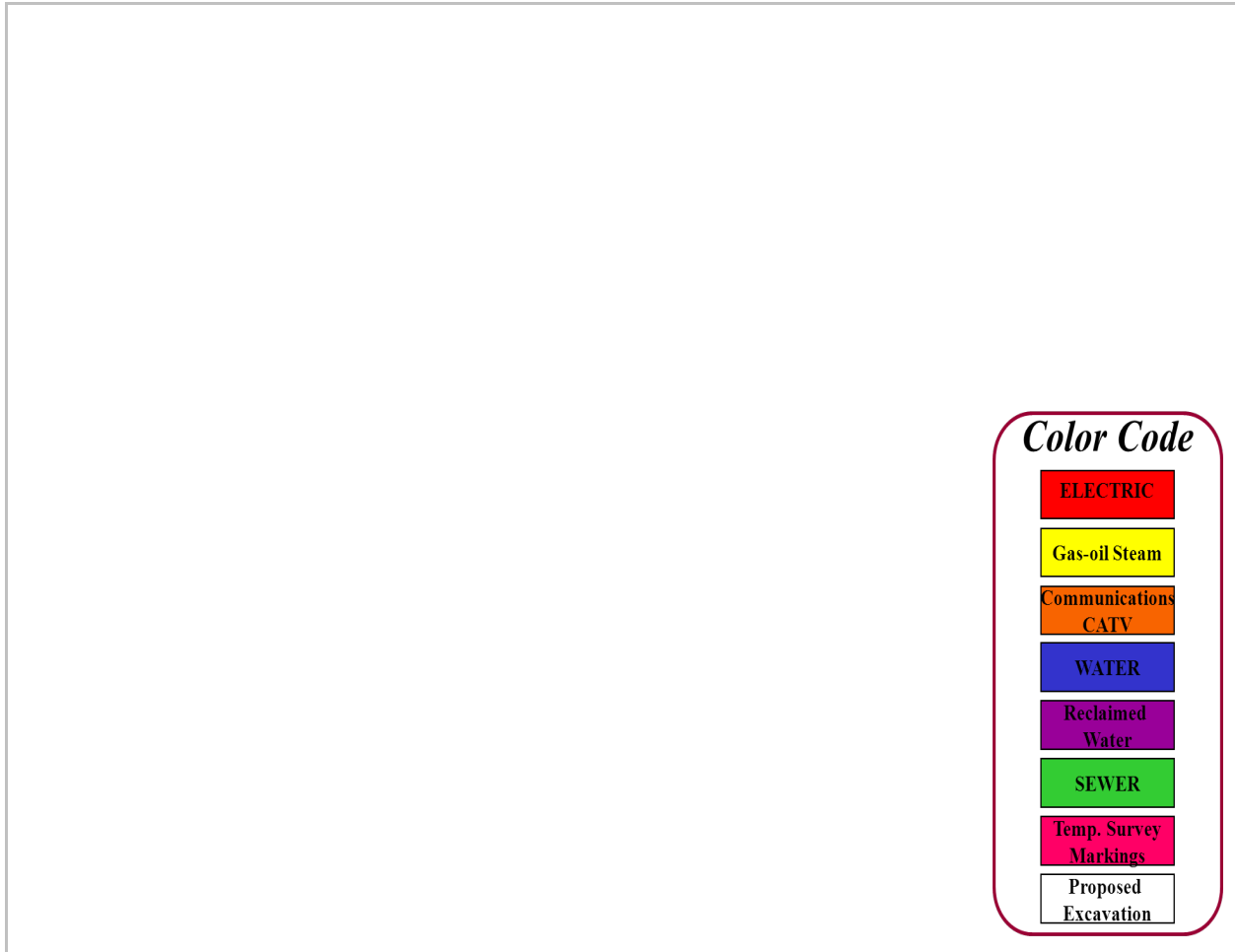

***Color Code***

ELECTRIC
Gas-oil Steam
Communications CATV
WATER
Reclaimed Water
SEWER
Temp. Survey Markings
Proposed Excavation

Other Comments / Findings:

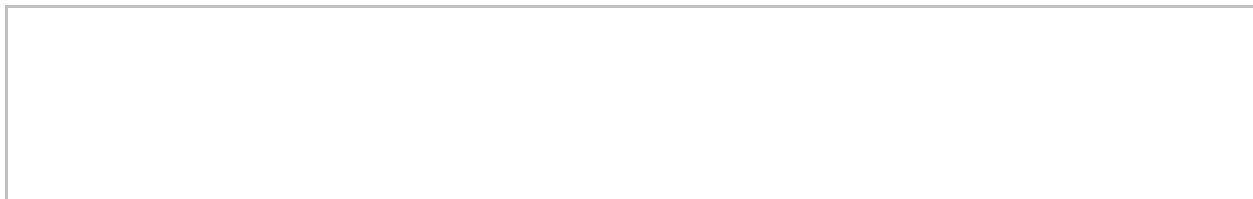

Completed by: \_\_\_\_\_

Signature: \_\_\_\_\_ Date: \_\_\_\_\_

**Site-Specific Health and Safety Plan  
The Peninsula Redevelopment Project  
1221 Spofford Avenue, Bronx, New York**

---

**APPENDIX E**

Heavy Equipment Exclusion Zone Policy

**HEAVY EQUIPMENT EXCLUSION ZONE  
MANAGEMENT PROGRAM**

**CORPORATE HEALTH AND SAFETY MANAGER : Brian Hobbs, CIH, CSP**  
**EFFECTIVE DATE : 07/18**  
**REVISION NUMBER : 1**

**TABLE OF CONTENTS**

1. PURPOSE..... 2

2. SCOPE AND APPLICABILITY..... 2

3. PROCEDURES..... 2

    3.1 Exceptions..... 3

4. TRAINING..... 3



## 1. PURPOSE

The purpose of the Exclusion Zone Management Program is to establish the minimum clearance distance that must be maintained between workers and heavy equipment while equipment is in operation (i.e., engaged or moving). The intent is to have no personnel or equipment entering the Exclusion Zone while the equipment is in operation or moving to ensure that Roux and Subcontractor employees are not unnecessarily exposed to the hazards of the equipment.

## 2. SCOPE AND APPLICABILITY

This Management Program applies to all Roux Associates, Inc. and its affiliated companies, Roux Environmental Engineering and Geology, D.P.C, and Remedial Engineering (collectively, "Roux") employees and their subcontractors who are performing field work and are potentially exposed to heavy equipment. For the purpose of this program, heavy equipment includes, but is not necessarily limited to: excavation equipment, drill rigs, vacuum trucks, forklifts, lull telehandlers, man lifts, bobcats, delivery trucks, etc.

## 3. PROCEDURES

As specified in the following sections of this Program, an Exclusion Zones must be established and maintained during activities involving the movement/operation of heavy equipment. The Exclusion Zone requirements apply to all personnel on the site but are primarily focused on those personnel who are required to be working in the vicinity of the equipment. The exclusion zone is in effect when heavy equipment is moving or engaged (ex. movement of an arm or bucket of an excavator, rotation of an auger, lifting of a load with a forklift, raising/lowering of a man lift, etc.).

1. The Exclusion Zone must meet the following minimum requirements:

- A minimum distance of 10 feet from all heavy equipment and loads being moved by the equipment;
- Greater than the swing/reach radius of any moving part on the heavy equipment (i.e., for large equipment this may mean an exclusion zone distance larger than 20 feet);
- Greater than the tip-over distance of the heavy equipment; and
- Greater than the radius of blind spots.

The size of the Exclusion Zone will need to be determined on a task-specific basis considering the size of the heavy equipment in use and the task being performed. Prior to all heavy equipment operations, the Exclusion Zone(s) distance must be specifically identified in the Job Safety Analysis (JSA).

2. The spotter (or another individual) should be assigned responsibility for enforcing the Exclusion Zone. The spotter should be positioned immediately outside of the Exclusion Zone within a clear line of sight of the equipment operator. The spotter must signal the operator to stop work if anyone or anything has the potential to enter or compromise the Exclusion Zone. The operator should stop work if the spotter is not within his/her line of sight. If multiple pieces of equipment are being used, each piece of equipment must have its own Exclusion Zone and spotter. For large excavation and demolition projects the spotter should be in constant radio contact (not cell phone) with the machine driver.
3. If an individual must enter the Exclusion Zone, the designated Spotter must signal the Equipment Operator to stop the equipment. Once the equipment is no longer moving (ex. movement of an arm of an excavator is STOPPED, lifting of a load with a forklift STOPPED, raising/lowering of a man lift is

STOPPED, etc.), the operator must DISENGAGE THE CONTROLS and STOP and SIGNAL BY “SHOWING HIS HANDS”. This signal will indicate that it is safe for the personnel to enter the limits of the Exclusion Zone to perform the required activity. The equipment must remain completely stopped/disengaged until all personnel have exited the limits of the Exclusion Zone and the designated Spotter has signaled by “SHOWING HIS HANDS” to the Equipment Operator that it is safe to resume operations.

4. When entering the limits of the Exclusion Zone, personnel must at a minimum:
  - Establish eye contact with the operator and approach the heavy equipment in a manner that is in direct line of sight to the Equipment Operator;
  - Never walk under any suspended loads or raised booms/arms of the heavy equipment; and
  - Identify a travel path that is free of Slip/Trip/Fall hazards.
5. The Exclusion Zone should be delineated using cones with orange snow fence or solid poles between the cones, barrels, tape or other measures. For work in rights-of-way rigid barriers, such as Jersey barriers or temporary chain link fence should be used. For certain types of wide-spread or moving/mobile equipment operations, such delineation may not be practicable around pieces of equipment or individual work areas. In such instances, it is expected that the entire operation will be within a larger secure work area or that additional means will be utilized to ensure security of the work zone.

All subcontractors who provide heavy equipment operations to field projects must implement a program that meets or exceeds the expectations described above as well as any additional requirements that may be required on a client or site-specific basis.

### **3.1 Exceptions**

It is recognized that certain heavy equipment activities may require personnel to work within the limits of the Exclusion Zone as specified in this program. Such activities may include certain excavation clearance tasks, drill crew activities or construction tasks. However, any such activity must be pre-planned with emphasis on limiting the amount and potential exposure of any activity required within the zone. The critical safety steps to mitigate the hazards associated with working within the Exclusion Zone must be defined in the JSA and potentially other project-specific plans (i.e., critical lift plans, etc.), and approved by the Roux Project Principal and client representative, if required, prior to implementation.

### **4. TRAINING**

Many Roux projects have different requirements that are client-specific or site-specific in nature. It is the responsibility of the Project Principal (or Project Manager if delegated this responsibility by the Project Principal) to ensure that the workers assigned to his/her projects are provided orientation and training with respect to these client and/or site-specific requirements.

**Site-Specific Health and Safety Plan**  
***The Peninsula Redevelopment Project***  
***1221 Spofford Avenue, Bronx, New York***

---

**APPENDIX F**

Roux COVID-19 Interim Health and Safety Guidance

## COVID-19 INTERIM HEALTH AND SAFETY GUIDANCE

**CORPORATE HEALTH AND SAFETY MANAGER** : **Brian Hobbs, CIH, CSP**  
**EFFECTIVE DATE** : **03/2020**  
**REVISION DATE** : **05/04/2020**  
**REVISION NUMBER** : **3**

**TABLE OF CONTENTS**

1. PURPOSE ..... 1

2. SCOPE AND APPLICABILITY ..... 1

3. BACKGROUND ..... 1

4. TRAINING REQUIREMENTS..... 2

5. EXPOSURE RISK POTENTIAL ..... 2

6. EXPOSURE/SUSPECTED EXPOSURE ..... 3

7. WORKPLACE CONTROLS..... 5

8. INFECTION PREVENTION MEASURES ..... 5

9. CLOTH FACE COVERINGS ..... 7

10. HOTEL SELECTION PROCESS AND OVERNIGHT/REMOTE WORK..... 8

11. TRANSPORTATION-RENTAL CARS AND ROUX-OWNED VEHICLES ..... 8

**APPENDICES**

- A. How to Remove Gloves
- B. Job Safety Analysis-Working in Areas Affected by COVID-19
- C. Centers for Disease Control (CDC) Use of Cloth Face Coverings to Help Slow the Spread of COVID-19

## 1. PURPOSE

This guidance has been implemented to establish work practices, administrative procedures, and engineering controls to minimize potential exposure to SARS-CoV-2, the virus that causes COVID-19. The following guidance has been developed based on local, state and federal recommendations/requirements regarding COVID-19. The purpose of this document is to supplement existing site-specific Health and Safety Plans (HASPs) and provide interim health and safety guidance to minimize potential exposure to SARS-CoV-2. Should additional scientific information or regulatory information change, this document shall be updated accordingly.

## 2. SCOPE AND APPLICABILITY

This guidance covers all Roux employees and the subcontractors that Roux oversees. Site specific HASPs shall be developed to incorporate elements of mitigative measures against COVID-19 exposure. If work cannot be carried out in compliance with this guidance, the project shall be further evaluated by the Project Principal (PP), Office Manager (OM), and Corporate Health and Safety Manager (CHSM) prior to work authorization.

## 3. BACKGROUND

### ***What is COVID-19?***

COVID-19 is a respiratory illness that can spread from person to person. The virus that causes COVID-19 is a novel coronavirus that was first identified during an investigation into an outbreak in Wuhan, China. This virus continues to spread internationally and within the United States. There is currently no vaccine to prevent COVID-19.

### ***What are the symptoms of COVID-19?***

Reported illnesses have ranged from mild symptoms to severe illness and death for confirmed COVID-19 cases. Symptoms may appear 2 to 14 days following exposure to the virus. People with these symptoms or combinations of symptoms may have COVID-19:

- Cough
- Shortness of breath or difficulty breathing

*Or at least two of these symptoms:*

- Fever
- Chills
- Repeated shaking with chills
- Muscle pain
- Headache
- Sore throat
- New loss of taste or smell

If someone develops emergency warning signs for COVID-19, they should be instructed to get medical attention immediately. Emergency warning signs can include those listed below; however, this list is not all inclusive. Please consult your medical provider for any other symptoms that are severe or concerning.

- Trouble breathing
- Persistent pain or pressure in the chest
- New confusion or inability to arouse
- Bluish lips or face

**How does COVID-19 spread?****Person-to-person spread**

The virus is thought to spread mainly from person-to-person contact.

- Between people who are in close contact with one another (within about 6 feet).
- Through respiratory droplets produced when an infected person coughs, sneezes or talks.
  - These droplets can land in the mouths or noses of people who are nearby or possibly be inhaled into the lungs.
- Some recent studies suggested that COVID-19 may be spread by people who are not showing symptoms.

**Spread from contact with contaminated surfaces or objects**

It also may be possible that a person can get COVID-19 by touching a contaminated surface or object and then touching their mouth, nose, or possibly their eyes. Based on current data, this is not thought to be the main way the virus spreads.

According to the Centers for Disease Control and Prevention (CDC), people are thought to be most contagious when they are most symptomatic; however, there is a possibility for the virus to spread before an individual shows symptoms (asymptomatic).

**How easily the virus spreads**

How easily a virus spreads from person-to-person can vary. Several viruses, such as measles, are highly contagious while others do not spread as easily. Based on current data, COVID-19 spreads very easily and sustainably between people and suggests the virus is spreading more efficiently compared to influenza, but not as efficiently as measles.

**4. TRAINING REQUIREMENTS**

All employees with potential exposure to COVID-19 shall be provided training that incorporates COVID-19 exposure mitigation strategies, such as implementation of proper social distancing, personal hygiene (e.g., handwashing), as well as disinfection procedures, as outlined by CDC guidelines.

**5. EXPOSURE RISK POTENTIAL**

Worker risk of occupational exposure to COVID-19 can vary from very high, high, medium, or lower (caution) risk. This level of exposure is dependent on several factors, which can include industry type; need for contact within 6 feet of people known to be or suspected of being infected with COVID-19; density of work environment; and industrial setting (i.e., healthcare building, occupied interior work area, minimal ventilation).

Provided below is background risk level information taken from the U.S. Department of Labor Occupational Safety and Health Administration Guidance on preparing workplaces for COVID-19. Risk evaluations for each project shall be conducted by the PP and OM in consultation with the CHSM to ensure Roux employees and subcontractors remain within the lower exposure (caution) category. If it is identified there is a medium exposure risk or higher, further evaluation and mitigative measures shall be evaluated to reduce overall exposure risk prior to work authorization.

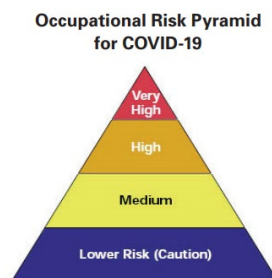

***Very High Exposure Risk (Activities not conducted by Roux)***

Very high exposure risk includes occupations/work activities with high potential for exposure to known or suspected sources of COVID-19 during specific medical, postmortem, or laboratory procedures. This can include but is not limited to:

- Healthcare workers (e.g., doctors, nurses, dentists, paramedics, emergency medical technicians) performing aerosol-generating procedures (e.g., intubation, cough induction procedures, bronchoscopies, some dental procedures and exams, or invasive specimen collection) on known or suspected COVID-19 patients.
- Healthcare or laboratory personnel collecting or handling specimens from known or suspected COVID-19 patients (e.g., manipulating cultures from known or suspected COVID-19 patients).
- Morgue workers performing autopsies, which generally involve aerosol-generating procedures on the bodies of people who are known to have, or suspected of having, COVID-19 at the time of their death.

***High Exposure Risk (Activities not conducted by Roux)***

High exposure risk occupations/work activities include exposure to known or suspected COVID-19 positive individuals. This can include but not limited to:

- Healthcare delivery and support staff (e.g., doctors, nurses, and other hospital staff who must enter patients' rooms) exposed to known or suspected COVID-19 patients. (Note: when such workers perform aerosol-generating procedures, their exposure risk level becomes very high.)
- Medical transport workers (e.g., ambulance vehicle operators) moving known or suspected COVID-19 patients in enclosed vehicles.
- Mortuary workers involved in preparing (e.g., for burial or cremation) the bodies of people who are known to have, or suspected of having, COVID-19 at the time of their death.

***Medium Exposure Risk***

Medium exposure risk occupations/work activities include those that require frequent and/or close contact with (i.e., within 6 feet of) people who may be infected with COVID-19, but who are not known or suspected to be COVID-19 positive. For most of our worksites, it is assumed there is on-going community transmission for COVID-19. Therefore, workers who work at sites and may have contact with the general public, other contractors, high-population-density work environments (i.e., greater than 10 people) fall within medium exposure risk group category. This can include, but is not limited to, sampling events that require two or more workers to collect and log samples in close contact or work occurring in an interior space with limited ventilation and several workers present.

***Lower Exposure Risk (Caution)***

Lower exposure risk (caution) occupations/work activities are those that do not require contact with people known to be or suspected of being COVID-19 positive. During these activities, there is limited contact (i.e., within 6 feet of) the general public or other workers. Workers in this category have minimal occupational contact with the public and other coworkers. This can include construction oversight that does not require close contact as well as sampling or gauging events performed by one worker.

**6. EXPOSURE/SUSPECTED EXPOSURE*****What do I do if I am sick or come into close contact with someone who is sick (e.g. living with/caring for)?***

If you or others you are living with/caring for experience any of the following symptoms, such as acute respiratory illness (i.e., cough, shortness of breath or difficulty breathing), chills, repeated shaking with chills, muscle pain, headache, sore throat, new loss of taste or smell or fever (100.4 °F [37.8 °C]), we ask you not report to your office/field site and stay home. Employees shall notify the OM immediately so proper notifications can be made.

Additionally, if you have come into close contact (i.e., within about 6 feet for at least 15 minutes) with someone who is experiencing COVID-19-like symptoms, please notify the OM immediately. Information provided shall be used to determine appropriate internal response in consultation with the CHSM and Human Resources Director (HRD).



***What if I am asked to self-isolate at home and when can I return from home isolation?***

Depending on the situation, if you are COVID-19 positive or suspected to have COVID-19, employees may be required to self-isolate in their homes as per CDC or local health department guidance. As per CDC guidance, return from isolation has been broken out into two categories. The first includes confirmed or suspected COVID-19 individuals exhibiting symptoms and the second includes those who have not had COVID-19 symptoms (i.e., asymptomatic) but tested positive and are under self-isolation. Both categories, along with strategies to return from home isolation, are outlined below.

**People with COVID-19 under isolation<sup>1</sup>:**

Options include a symptom-based (i.e., time-since-illness-onset and time-since-recovery strategy) or a test-based strategy.

**1) Symptom-based strategy**

If you have not had a test to determine if you are still contagious, you can leave home after these three things have happened:

- At least 3 days (72 hours) have passed since recovery defined as resolution of fever without the use of fever-reducing medications; and
- improvement in respiratory symptoms (e.g., when your cough or shortness of breath have improved); and
- at least 10 days have passed since symptoms first appeared.

**2) Test-based strategy**

If you will be tested to determine if you are still potentially contagious, you can leave home after these three things have happened:

- Resolution of fever without the use of fever-reducing medications; and
- improvement in respiratory symptoms (e.g., when your cough or shortness of breath have improved); and
- you received two negative tests in a row, at least 24 hours apart. Your doctor shall follow CDC guidance.

**People who have not had COVID-19 symptoms but tested positive and are under isolation<sup>1</sup>:**

Options include both a time-based or test-based strategy.

**1) Time-based strategy**

If you have not had a test to determine if you are still contagious, you can leave home after these two things have happened:

- At least 10 days have passed since the date of their first positive COVID-19 diagnostic test; and
- you continue to have no symptoms (no cough or shortness of breath, etc.) since the positive COVID-19 diagnostic test.

**2) Test-based strategy**

If you have had a test to determine if you are still contagious, you can leave home after:

- You received two negative tests in a row, at least 24 hours apart. Your doctor shall follow CDC guidance.

**Test-based strategies**

Previous recommendations for a test-based strategy remain applicable; however, a test-based strategy is contingent on the availability of ample testing supplies and laboratory capacity as well as convenient access to testing.

---

<sup>1</sup> In all cases, follow the guidance of your healthcare provider and local health department. The decision to stop home isolation should be made in consultation with your healthcare provider and state and local health departments. Local decisions depend on local circumstances.

## 7. WORKPLACE CONTROLS

During the project planning phase, worksite evaluations shall be carried out by the PP and OM in consultation with the CHSM to determine risk exposure levels for work activities. If it is determined there is a medium exposure risk level or higher, additional workplace controls shall be evaluated and implemented as required in addition to the basic infection prevention measures outlined below in Section 8. Additional workplace controls can include engineering controls (i.e., ventilation, physical barriers), administrative controls (i.e., minimizing contact between workers, rotating shifts, site specific training), and additional personal protective equipment (i.e., respiratory protection). If exposure risk cannot be mitigated, potential project postponement may be necessary at the discretion of the OM in consultation with the CHSM.

A Job Safety Analysis (JSA) has been developed and is provided in Appendix B which summarizes and applies concepts within this guidance including the infection prevention measures listed below. This JSA shall be required for all field work in areas where there is community-based transmission of COVID-19.

## 8. INFECTION PREVENTION MEASURES

The following is basic infection prevention and personal hygiene practices which shall be implemented for all Roux field activities as well as in the office setting.

- **Personal Hygiene**
  - Wash your hands often with soap and water for at least 20 seconds.
    - If soap and water are not available, use an alcohol-based sanitizer that contains at least 60% ethanol or 70% isopropanol.
    - Key times to wash your hands include after blowing your nose, coughing or sneezing, after using the restroom, and before eating or preparing food.
  - Do not touch your eyes, face, nose and mouth with unwashed hands.
  - Cover your mouth and nose with a tissue when you cough or sneeze or use the inside of your elbow.
  - Throw potentially contaminated items (e.g., used tissues) in the trash.
- **Avoid Close Contact/Secondary Contact with People and Potentially Contaminated Surfaces**
  - Apply appropriate social distance (6+ feet).
  - Stop handshaking—use and utilize other noncontact methods for greeting.
  - Do not work in areas with limited ventilation with other Site workers (e.g., small work trailer which lacks HVAC system). If working in a trailer, the following conditions must be met: limited to 4 workers, large enough to have the ability to apply social distance, and has open windows and/or operational HVAC to ensure proper ventilation of the workspace.
  - Morning tailgate/safety meetings shall occur outside and not within work trailers.
    - Do not require employees or subcontractors to sign in using the same tailgate form. The Site Supervisor/SHSO should record names of those in attendance on the form.
    - If the Site has more than 10 workers, separate tailgate meetings should be performed in smaller groups.
  - Do not share equipment or other items with co-workers and subcontractors unless wearing appropriate PPE (e.g. nitrile gloves). Assume equipment and other surfaces are potentially contaminated and remove gloves aseptically.
  - If receiving labware or other equipment disinfect to the extent feasible. If there are concerns for contaminating labware please wear appropriate PPE (e.g. gloves) to minimize contact.
  - Contact your lab/equipment vendor to confirm equipment is properly disinfected prior to being shipped.
  - Do not carpool with others (e.g. clients, coworkers).

- For company owned vehicles limit sharing of vehicles with coworkers. If unable to limit sharing of company owned vehicles, properly disinfect vehicle before driving with a focus on commonly touched surfaces (e.g. steering wheels, shifters, buttons, etc.).
- Use caution when using public restrooms, portable toilets. Use paper towel as a barrier when touching door handles and faucets.
- **Cleaning and Disinfecting**
  - Clean and disinfect frequently touched surfaces daily. Commonly touched items can include but are not limited to tables, doorknobs, light switches, countertops, handles, desks, phones, keyboards, toilets, faucets, sinks, and field equipment (i.e., photo-ionization detector, field equipment).
  - **Hard (Non-porous) Surfaces**
    - If surfaces are dirty, they should be cleaned with a detergent/soap and water prior to disinfection.
    - Refer to the manufacturer's instructions to ensure safe and effective use of the product and wear appropriate personal protective equipment (e.g., gloves, safety glasses, face shield).
    - Many products require:
      - Keeping surface wet for a period of time (i.e. contact time)
        - Refer to manufacturer's instructions outlining adequate contact time.
      - Precautions such as wearing gloves and making sure you have good ventilation during use of the product.
    - Disposable gloves should be removed aseptically and discarded after cleaning. Wash hands immediately following removal of gloves. Refer to Appendix A for how to remove gloves aseptically.
    - For disinfection, diluted household bleach solutions, alcohol solutions with at least 70% alcohol, and most common EPA-registered household disinfectants should be effective.
      - Diluted household bleach solutions can be used if appropriate for the surface. Follow manufacturer's instructions for application and proper ventilation. Check to ensure the product is not past its expiration date. Never mix household bleach with ammonia or any other cleanser. Unexpired household bleach will be effective against coronaviruses when properly diluted. Leave the solution on the surface for at least 1 minute.
        - Prepare a bleach solution by mixing:
          - 5 tablespoons (1/3 cup) bleach per gallon of water or
          - 4 teaspoons bleach per quart of water
    - [Products with EPA-approved emerging viral pathogen claims are expected to be effective against COVID-19](#). Follow the manufacturer's instructions for all cleaning and disinfecting products (e.g., concentration, application method and contact time, etc.).
  - **Soft (Porous) Surfaces**
    - For soft (porous) surfaces, remove visible contamination if present and clean with appropriate cleaners indicated for use on the surfaces. After cleaning:
      - Launder items as appropriate in accordance with the manufacturer's instructions. If possible, launder using the warmest appropriate water setting for the item and dry items completely; or
      - Use products with the EPA-approved emerging viral pathogens that claim they are suitable for porous surfaces.
  - **Electronics**
    - For electronics such as tablets, touch screens, keyboards, remote controls, etc. remove visible contamination if present.
      - Follow the manufacturer's instructions for all cleaning and disinfection products.
      - Consider use of wipeable covers for electronics.

- If no manufacturer guidance is available, consider the use of alcohol-based wipes or sprays containing at least 70% alcohol to disinfect touch screens. Dry surfaces thoroughly to avoid pooling of liquids.
- ***Linens, Clothing, and Other Items that Go in the Laundry***
  - Although it is unlikely field clothing would become potentially contaminated with COVID-19, it is recommended that field staff regularly launder field clothing following any field event upon returning home.
  - In order to minimize the possibility of dispersing the virus from potentially contaminated clothing, do not shake dirty laundry.
  - Wash items as appropriate in accordance with the manufacturer's instructions. If possible, launder items using the warmest appropriate water setting for the items and dry items completely.
  - Clean and disinfect hampers or other containers used for transporting laundry according to guidance listed above.

## **9. CLOTH FACE COVERINGS**

The CDC recommends the use of cloth face coverings in public settings where other social distancing measures are difficult to maintain, such as grocery stores and pharmacies, and especially in areas of significant community-based transmission. This recommendation is based on recent studies and an understanding that a significant portion of asymptomatic, as well as pre-symptomatic, individuals can shed the virus to others before showing symptoms. Studies indicate that COVID-19 can spread among people interacting in close proximity through speaking, coughing, or sneezing. The purpose of the cloth covering is NOT to provide protection to the wearer, but to protect the wearer from unknowingly infecting others if they are asymptomatic/pre-symptomatic. The use of cloth face coverings is to supplement and NOT replace the existing practices outlined above.

Based on existing studies and on-going recommendations and/or requirements from federal, state, and local entities, Roux is recommending the use of cloth face coverings, when appropriate. Appropriate use is defined when local authorities or clients require the use of cloth face coverings in conjunction with established social distancing, or if an employee elects to use a cloth covering on their own accord. Roux will provide cloth face coverings that shall meet the basic requirements outlined by the CDC guidance provided in Appendix C: CDC Use of Cloth Face Coverings to Help Slow the Spread of COVID-19.

Cloth Face Coverings should:

- Fit snugly but comfortably against the side of the face;
- Be secured with ties or ear loops, when possible;
- May include multiple layers of fabric;
- Allow for breathing without restriction; and
- Be able to be laundered and machine dried with no damage or change to shape.

When donning and doffing the cloth face covering, individuals should avoid touching their eyes, nose, and mouth. Following removal of the cloth face covering, employees should wash their hands immediately using the guidelines described in Section 8 above. Cloth face coverings should be routinely washed depending on the frequency of use.

The use of existing cloth covering products/materials, such as a scarf, neck gaiter, or bandana, is deemed acceptable by the CDC. Note, the cloth face coverings recommended are not surgical masks or N-95 respirators. Those are critical supplies that must continue to be reserved for healthcare workers and other medical first responders, as recommended by current CDC guidance. Should there be a requirement for workers to be in respiratory protection (e.g. full-face respirator w/cartridges, P100, N95 respirators), it shall be addressed during the project pre-planning phase, which includes discussions with the PP and OM in consultation with CHSM.

## **10. HOTEL SELECTION PROCESS AND OVERNIGHT/REMOTE WORK**

### ***Hotel Selection***

Due to the current COVID-19 situation, Roux is recommending overnight travel be limited to the extent possible. If there is a project requiring the overnight stay at a hotel, accommodations shall be made only after the hotel and hotel's location have been vetted in accordance with Roux's established guidance as defined below. The Project Team, which includes the Project Manager (PM) and PP along with the OM, in consultation with the CHSM, shall verify the hotel has appropriate protocols in place to limit the potential exposure and spread of COVID- 19 through proper cleaning and disinfection practices. Discussions with the hotel shall include, but are not limited to, measures taken to keep guests safe during their stay, guest room sanitization schedule, training of staff regarding disinfecting protocols using EPA-approved disinfectants, hotel staff fitness for duty requirements, etc. Following the initial hotel assessment by the Project Team, the OM and the CHSM shall review the hotel assessment findings prior to the CHSM's authorization that the hotel may be used by any Roux employees.

Employees staying overnight should abide by the following guidance:

- Ensure you properly disinfect your room upon arrival. This should include a wipe down of all commonly touched surfaces with an approved disinfectant. Use appropriate PPE (e.g. nitrile gloves) when disinfecting surfaces.
- Place the "Do Not Disturb" placard on the room while away and consider limiting hotel housekeeping service to the extent feasible ( e.g., not having the room cleaned each day) to minimize potential secondary contact with others.
- Do not spend any more time in hotel common areas (i.e., lobby, hallways, etc.) than is necessary.
- Follow proper Infection Prevention Measures found within Section 8 above.
- Have meals in your hotel room after disinfecting outer package surfaces, as outlined in Section 8 above. Do not eat in public spaces or restaurants.
- If the hotel has a restaurant or café, do not have your meal in a common area; instead order food to be picked up or delivered to your room. If delivered, opt for contactless delivery (left outside the door, delivery person knocks and leaves). Always use your own pen if you need to sign something.
- Employees may also pick up food from takeout locations, order groceries or food for delivery to the hotel. Call local restaurants to order food for delivery (call the hotel lobby for recommendations) or use food ordering apps. Some apps have options for contactless delivery.

## **11. TRANSPORTATION-RENTAL CARS AND ROUX-OWNED VEHICLES**

### ***Rental Cars***

Due to the current COVID-19 situation, Roux recommends rental car usage be limited to the extent possible. If there is a project requiring the use of a rental car (e.g. truck/van), accommodations shall be made only after the rental car company and their store's location have been vetted in accordance with Roux's established guidance, as defined below. The Project Team (PM and PP) and OM in consultation with the CHSM shall verify the rental company where you are picking up your vehicle has appropriate protocols in place to limit the potential exposure and spread of COVID- 19 through proper cleaning and disinfection practices. Discussions with the rental car company shall include, but are not limited to, measures to be taken to keep customers safe during pickup/drop-off, rental car disinfection protocols, training of staff regarding disinfecting protocols using EPA-approved disinfectants, rental car company staff fitness for duty requirements, etc. Following the initial rental car company store assessment by the Project Team, the OM and the CHSM shall review the rental car company assessment findings prior to the CHSM's authorization that the rental car company store may be used by any Roux employees.

Upon vehicle pickup, employees shall don nitrile gloves and safety glasses and clean/disinfect all high-touch surfaces (steering wheel, knobs, door handles, turn signals, radio, etc.) by wiping thoroughly with approved disinfectants (following manufacturer's instructions). Aseptically remove gloves and dispose of them along with

rags/wipes, appropriately. Wash hands or use hand sanitizer immediately after each episode of cleaning. Due to social distancing requirements, personnel shall not carpool to destinations.

***Roux-Owned Vehicles***

Due to the current COVID-19 situation, Roux-owned vehicles should be dedicated to individual employees to the extent feasible, and if authorized by the OM. In the case this cannot be accommodated, employees shall don nitrile gloves and safety glasses and clean/disinfect all high-touch surfaces (steering wheel, knobs, door handles, turn signals, radio, etc.) by wiping thoroughly with approved disinfectants (following manufacturer's instructions). This cleaning and disinfection shall occur before and after each use of the vehicle. Aseptically remove gloves and dispose of them along with rags/wipes, appropriately. Wash hands or use hand sanitizer immediately after each episode of cleaning. Due to social distancing requirements, personnel shall not carpool to destinations.

**APPENDIX A**  
**How to Remove Gloves**

# How to Remove Gloves

To protect yourself, use the following steps to take off gloves



1 Grasp the outside of one glove at the wrist.  
Do not touch your bare skin.



2 Peel the glove away from your body,  
pulling it inside out.



3 Hold the glove you just removed in  
your gloved hand.

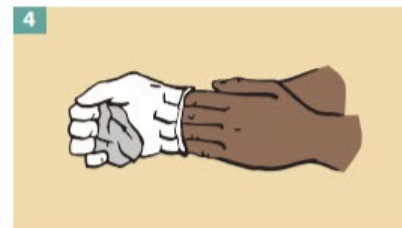

4 Peel off the second glove by putting your fingers  
inside the glove at the top of your wrist.



5 Turn the second glove inside out while pulling  
it away from your body, leaving the first glove  
inside the second.



6 Dispose of the gloves safely. Do not reuse the gloves.



7 Clean your hands immediately after removing gloves.



## APPENDIX B

### Job Safety Analysis-Working in Areas Affected by COVID-19

JOB SAFETY ANALYSIS Ctrl. No. CVD-19		DATE: 04/16/2020	<input checked="" type="checkbox"/> NEW <input type="checkbox"/> REVISED	PAGE 1 of 2
JSA TYPE CATEGORY <b>Generic</b>	WORK TYPE <b>Fieldwork</b>	WORK ACTIVITY (Description) <b>Working in Areas Affected by Coronavirus</b>		
<b>DEVELOPMENT TEAM</b>	<b>POSITION / TITLE</b>	<b>REVIEWED BY:</b>	<b>POSITION / TITLE</b>	
Kristina DeLuca	Health and Safety Specialist	Brian Hobbs	CHSM	
<b>REQUIRED AND / OR RECOMMENDED PERSONAL PROTECTIVE EQUIPMENT</b>				
<input type="checkbox"/> LIFE VEST <input checked="" type="checkbox"/> HARD HAT – In field <input type="checkbox"/> LIFELINE / BODY HARNESS <input checked="" type="checkbox"/> SAFETY GLASSES – In field	<input type="checkbox"/> GOGGLES <input type="checkbox"/> FACE SHIELD <input type="checkbox"/> HEARING PROTECTION <input checked="" type="checkbox"/> SAFETY SHOES – Steel/composite toe in fie	<input type="checkbox"/> AIR PURIFYING RESPIRATOR <input type="checkbox"/> SUPPLIED RESPIRATOR <input checked="" type="checkbox"/> PPE CLOTHING – High visibility vest in field	<input checked="" type="checkbox"/> GLOVES – Leather/cut-resistant in field and nitrile as needed <input type="checkbox"/> OTHER	
<b>REQUIRED AND / OR RECOMMENDED EQUIPMENT</b>				
Cloth face covering, nitrile gloves, hand soap, water source, hand sanitizer, disinfectant spray and disinfectant wipes.				
<b>Commitment to Safety – All personnel onsite will actively participate in SPSA performance by verbalizing SPSAs throughout the day.</b>				
<b>SOCIAL DISTANCING: Maintain 6' of distance between yourself and all other people at all times. If you do not believe the scope of work can be conducted while maintaining this distance, contact your Project Manager immediately.</b>				
<b>Assess 1JOB STEPS</b>	<b>Analyze 2POTENTIAL HAZARDS</b>	<b>Act 3CRITICAL ACTIONS</b>		
1. Project Preplanning	N/A	<ul style="list-style-type: none"> <li>Review and follow COVID-19 CDC, Roux, Client and local orders/protocols.</li> <li>Ensure all workers are fit for duty - anyone feeling sick should remain at home even if symptoms do not align with COVID-19. If a worker has been in contact with someone potentially positive or positive for COVID-19, contact your Office Manager.</li> <li>Determine PPE needs and ensure adequate supply of disinfectant wipes/spray, soap and water or hand sanitizer at Site. Due to high demands and limited supply, plan ahead.</li> <li>Use the minimum number of employees necessary to safely complete the work.</li> </ul>		
2. Mobilization	<b>Exposure:</b> Becoming infected or infecting co-workers	<p><b>Personal/Rental/Roux Owned Vehicle</b></p> <ul style="list-style-type: none"> <li>Do not carpool.</li> <li>Use the same vehicle every day and do not share with co-workers.</li> <li>Verify workers/other people are not approaching vehicle prior to exiting the vehicle. Maintain 6' of distance from others.</li> <li>DO not valet your car or allow others to use your car. If necessary, don nitrile gloves and safety glasses and clean/disinfect all high touch surfaces (steering wheel, knobs, door handles, turn signals, radio, etc.) by wiping thoroughly with approved disinfectants (follow manufacturer's instructions). This cleaning and disinfection shall occur before and after each use of the vehicle. Aseptically remove gloves and dispose of them along with rags/wipes, appropriately. Wash hands or use hand sanitizer immediately after each episode of cleaning.</li> </ul> <p><b>Public Transportation</b></p> <ul style="list-style-type: none"> <li>Public transit should not be used unless absolutely necessary. Consider renting a car rather than taking public transit. If public transit is required, wear appropriate PPE and apply social distancing (6 ft). Use proper donning and doffing procedures for nitrile gloves. Wash hands or use hand sanitizer immediately after.</li> </ul> <p><b>Hotel Stay (Refer to COVID-19 H&amp;S Guidance for more info)</b></p> <ul style="list-style-type: none"> <li>If a hotel stay is deemed necessary for the given field work, ensure that you disinfect your room upon initial arrival and returning each day. Disinfect all surfaces of your room with an appropriate disinfectant using nitrile gloves. Use proper donning and doffing procedures for nitrile gloves.</li> <li>Place the "Do Not Disturb" placard on the room while away and limit housekeeping services to the extent feasible during your stay to minimize the reintroduction and spread of the virus from others. Minimize, or avoid entirely, time spent in hotel common areas (i.e., the lobby, dining areas, gyms, etc.). Wash hands or use hand sanitizer often.</li> </ul>		

<sup>1</sup> Each Job or Operation consists of a set of tasks / steps. Be sure to list all the steps needed to perform job.

<sup>2</sup> A hazard is a potential danger. Break hazards into six types: Contact - victim is struck by or strikes an object; Caught - victim is caught on, caught in or caught between objects; Fall - victim falls to ground or lower level (includes slips and trips); Exertion - excessive strain or stress / ergonomics / lifting techniques; Exposure - inhalation/skin hazards, energy source; Energy Source – electricity, pressure, compression/tension.

<sup>3</sup> Using the first two columns as a guide, decide what actions or procedures are necessary to eliminate or minimize the risk. List the recommended safe operating procedures. Say exactly what needs to be done - such as "use two persons to lift". Avoid general statements such as, "be careful".

3. Tailgate Meeting	<b>Exposure:</b> Becoming infected or infecting co-workers	<ul style="list-style-type: none"> <li>• Must occur outside or remotely (i.e. video or conference call).</li> <li>• Maintain at least a 6+ ft distance between you and others.</li> <li>• Discuss primary infection prevention measures listed below.</li> <li>• Do not require employees or subcontractors to sign in, the Site Supervisor shall record names on the attendance form.</li> <li>• If the Site has more than 10 workers, separate tailgate meetings should be performed.</li> <li>• Discuss COVID-19 symptoms with coworkers and subcontractors to ensure fitness for duty. Anyone exhibiting signs or symptoms should be instructed to leave the Site, contact your Project Manager.</li> </ul>
4. Site Activities	<b>Exposure:</b> Becoming infected or infecting co-workers	<ul style="list-style-type: none"> <li>• Coordinate field activities at the beginning of the day (i.e. Tailgate meeting) to minimize time spent in crowded spaces or overlap while completing job tasks.</li> <li>• Don cloth face coverings as appropriate.</li> <li>• Apply social distancing (6+ ft) when interacting with others. If anyone comes within 6 ft of you while conducting work and your work prevents you from moving away, politely ask them to move back. If others are unable to move from your space, stop work and leave area.</li> <li>• Do not shake hands or touch others.</li> <li>• Do not share equipment or other items with co-workers and subcontractors unless wearing appropriate PPE (e.g. nitrile gloves). Assume equipment and other surfaces are potentially contaminated and remove gloves aseptically (See Appendix A of Roux Interim H&amp;S Guidance for proper glove removal).</li> <li>• If anyone is coughing or sneezing in your vicinity, stop work and leave the area.</li> <li>• Do not work in areas with limited ventilation with others.</li> <li>• Cover your mouth and nose with tissue or paper towel or with your elbow when coughing or sneezing and wash hands or use hand sanitizer immediately after. If sick contact SHSO/PM and leave Site immediately.</li> <li>• Disinfect work surfaces/areas with approved disinfectant you're responsible for (ex: desk, office doorknob, computer, etc.) at least once at the beginning of your shift and at least once at the end of your shift with either sanitizing wipes or disinfectant spray.</li> <li>• Phones should be operated hands free to extent feasible. Sanitize your phone on a regular basis. Disinfection should also take place whenever suspected contaminated material comes in contact with any work surfaces/areas. Wash hands or use hand sanitizer immediately after.</li> <li>• Avoid public spaces and going out to eat by bringing your own lunch to the Site. If performing work in high density urban areas, it is recommended all food must be consumed at or in your vehicle. Wash hands or use hand sanitizer before eating and immediately after.</li> </ul>

### Primary Infection Prevention Measures

- Wash your hands often with soap and water for at least 20 seconds.
  - If soap and water are not available, use an alcohol-based sanitizer that contains at least 60% ethanol or 70% isopropanol. Key times to wash hands include after blowing your nose, coughing or sneezing, after using the restroom, and before eating or preparing food.
- Do not touch your eyes, face, nose and mouth with unwashed hands.
- Cover your mouth and nose with a tissue when you cough or sneeze or use the inside of your elbow. Throw potentially contaminated items (e.g. used tissues) in the trash.
- Avoid close contact/secondary contact with people and potentially contaminated surfaces.
  - Apply appropriate social distance (6+ feet).
  - Stop handshaking/touching others and use caution when accessing public spaces.
- Clean and disinfect frequently touched surfaces daily. Commonly touched items can include but are not limited to tables, doorknobs, light switches, countertops, handles, desks, phones, keyboard, toilets, sinks and field equipment. If surfaces are dirty, they should be cleaned with soap and water prior to disinfection. If surface cannot be cleaned/disinfected, then wash hands or use sanitizer as soon as possible.

<sup>1</sup> Each Job or Operation consists of a set of tasks / steps. Be sure to list all the steps needed to perform job.

<sup>2</sup> A hazard is a potential danger. Break hazards into six types: Contact - victim is struck by or strikes an object; Caught - victim is caught on, caught in or caught between objects; Fall - victim falls to ground or lower level (includes slips and trips); Exertion - excessive strain or stress / ergonomics / lifting techniques; Exposure - inhalation/skin hazards; Energy source – electricity, pressure, compression/tension.

<sup>3</sup> Using the first two columns as a guide, decide what actions or procedures are necessary to eliminate or minimize the risk. List the recommended safe operating procedures. Say exactly what needs to be done - such as "use two persons to lift". Avoid general statements such as, "be careful".

**APPENDIX C****Centers for Disease Control (CDC)  
Use of Cloth Face Coverings to Help Slow the Spread of COVID-19**

# Use of Cloth Face Coverings to Help Slow the Spread of COVID-19

## How to Wear Cloth Face Coverings

Cloth face coverings should—

- fit snugly but comfortably against the side of the face
- be secured with ties or ear loops
- include multiple layers of fabric
- allow for breathing without restriction
- be able to be laundered and machine dried without damage or change to shape

## CDC on Homemade Cloth Face Coverings

CDC recommends wearing cloth face coverings in public settings where other social distancing measures are difficult to maintain (e.g., grocery stores and pharmacies), **especially** in areas of significant community-based transmission.

CDC also advises the use of simple cloth face coverings to slow the spread of the virus and help people who may have the virus and do not know it from transmitting it to others. Cloth face coverings fashioned from household items or made at home from common materials at low cost can be used as an additional, voluntary public health measure.

Cloth face coverings should not be placed on young children under age 2, anyone who has trouble breathing, or is unconscious, incapacitated or otherwise unable to remove the cloth face covering without assistance.

The cloth face coverings recommended are not surgical masks or N-95 respirators. Those are critical supplies that must continue to be reserved for healthcare workers and other medical first responders, as recommended by current CDC guidance.

## Should cloth face coverings be washed or otherwise cleaned regularly? How regularly?

Yes. They should be routinely washed depending on the frequency of use.

## How does one safely sterilize/clean a cloth face covering?

A washing machine should suffice in properly washing a cloth face covering.

## How does one safely remove a used cloth face covering?

Individuals should be careful not to touch their eyes, nose, and mouth when removing their cloth face covering and wash hands immediately after removing.

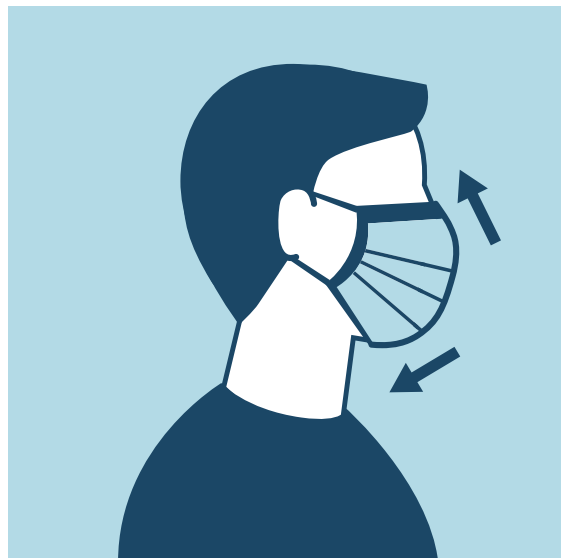

# Sewn Cloth Face Covering

## Materials

- Two 10"x6" rectangles of cotton fabric
- Two 6" pieces of elastic (or rubber bands, string, cloth strips, or hair ties)
- Needle and thread (or bobby pin)
- Scissors
- Sewing machine

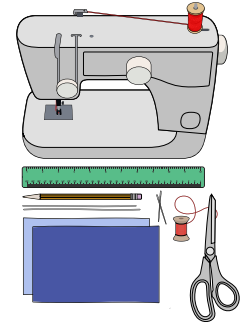

## Tutorial

1. Cut out two 10-by-6-inch rectangles of cotton fabric. Use tightly woven cotton, such as quilting fabric or cotton sheets. T-shirt fabric will work in a pinch. Stack the two rectangles; you will sew the cloth face covering as if it was a single piece of fabric.

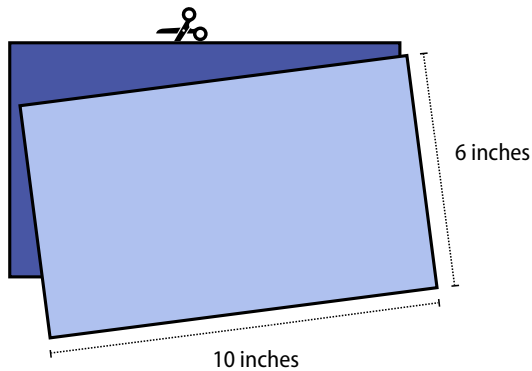

2. Fold over the long sides  $\frac{1}{4}$  inch and hem. Then fold the double layer of fabric over  $\frac{1}{2}$  inch along the short sides and stitch down.

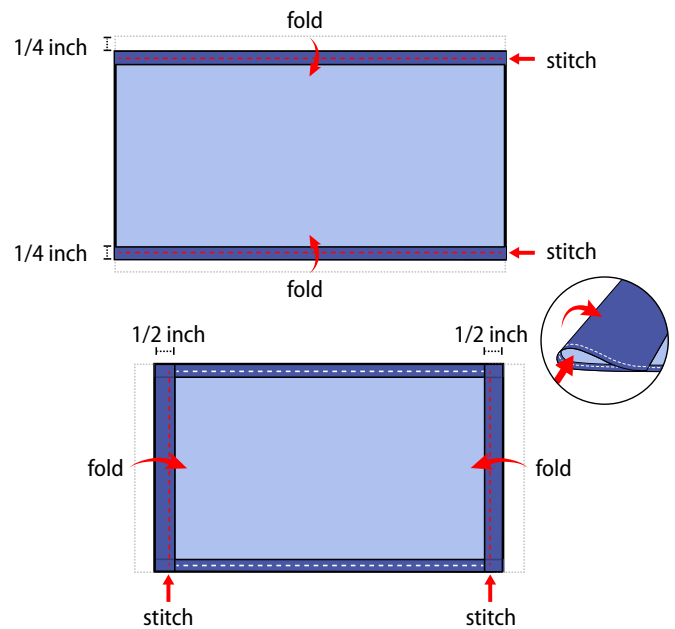

3. Run a 6-inch length of  $\frac{1}{8}$ -inch wide elastic through the wider hem on each side of the cloth face covering. These will be the ear loops. Use a large needle or a bobby pin to thread it through. Tie the ends tight. Don't have elastic? Use hair ties or elastic head bands. If you only have string, you can make the ties longer and tie the cloth face covering behind your head.

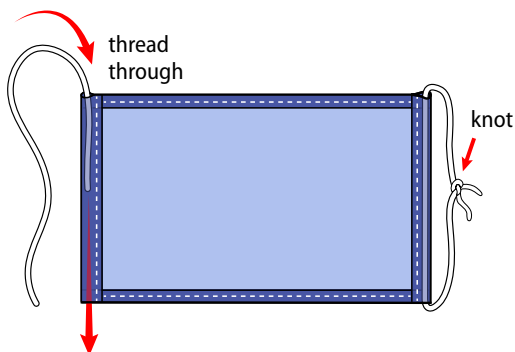

4. Gently pull on the elastic so that the knots are tucked inside the hem. Gather the sides of the cloth face covering on the elastic and adjust so the mask fits your face. Then securely stitch the elastic in place to keep it from slipping.

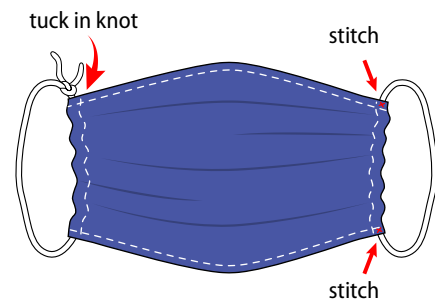

## Quick Cut T-shirt Cloth Face Covering (no sew method)

### Materials

- T-shirt
- Scissors

### Tutorial

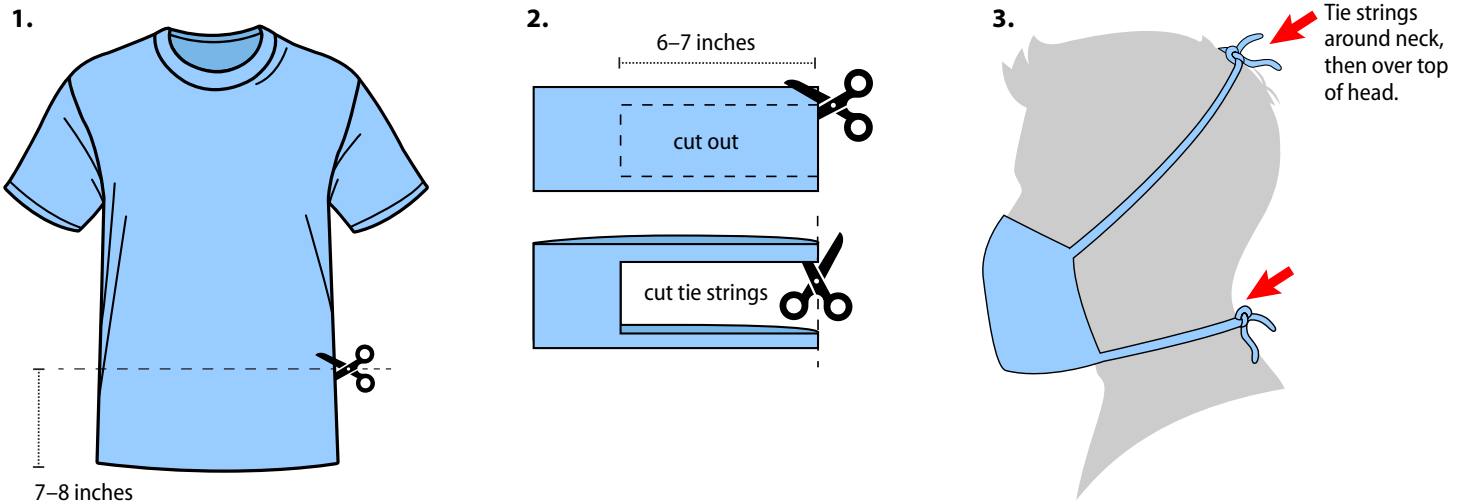

## Bandana Cloth Face Covering (no sew method)

### Materials

- Bandana (or square cotton cloth approximately 20"x20")
- Rubber bands (or hair ties)
- Scissors (if you are cutting your own cloth)

### Tutorial

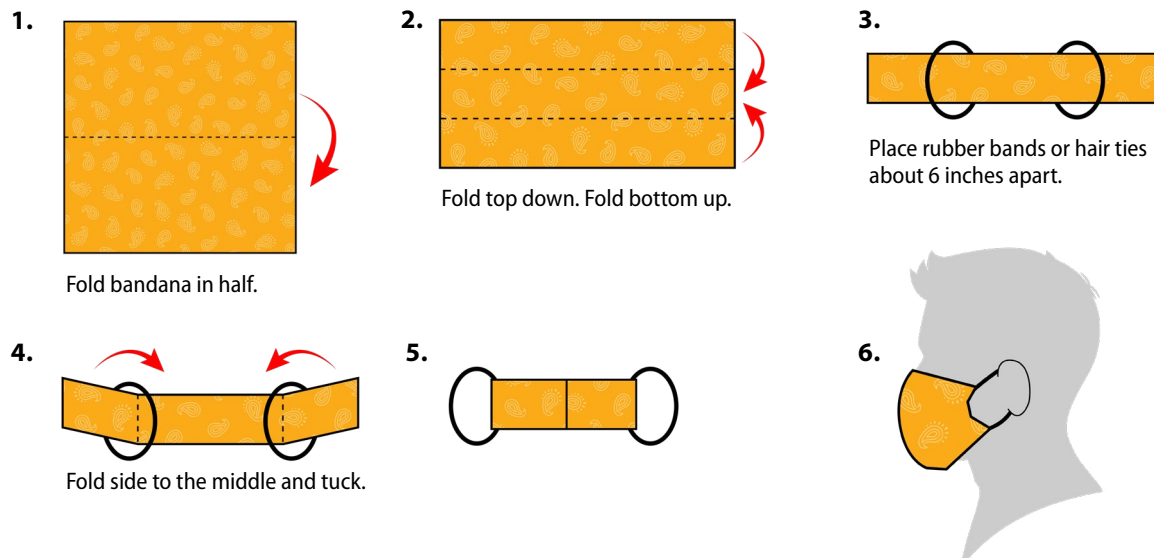

**Site-Specific Health and Safety Plan  
The Peninsula Redevelopment Project  
1221 Spofford Avenue, Bronx, New York**

---

**APPENDIX G**

**CDC's Face Covering Procedure**



# Use of Cloth Face Coverings to Help Slow the Spread of COVID-19

## How to Wear Cloth Face Coverings

Cloth face coverings should—

- fit snugly but comfortably against the side of the face
- be secured with ties or ear loops
- include multiple layers of fabric
- allow for breathing without restriction
- be able to be laundered and machine dried without damage or change to shape

## CDC on Homemade Cloth Face Coverings

CDC recommends wearing cloth face coverings in public settings where other social distancing measures are difficult to maintain (e.g., grocery stores and pharmacies), **especially** in areas of significant community-based transmission.

CDC also advises the use of simple cloth face coverings to slow the spread of the virus and help people who may have the virus and do not know it from transmitting it to others. Cloth face coverings fashioned from household items or made at home from common materials at low cost can be used as an additional, voluntary public health measure.

Cloth face coverings should not be placed on young children under age 2, anyone who has trouble breathing, or is unconscious, incapacitated or otherwise unable to remove the cloth face covering without assistance.

The cloth face coverings recommended are not surgical masks or N-95 respirators. Those are critical supplies that must continue to be reserved for healthcare workers and other medical first responders, as recommended by current CDC guidance.

## Should cloth face coverings be washed or otherwise cleaned regularly? How regularly?

Yes. They should be routinely washed depending on the frequency of use.

## How does one safely sterilize/clean a cloth face covering?

A washing machine should suffice in properly washing a cloth face covering.

## How does one safely remove a used cloth face covering?

Individuals should be careful not to touch their eyes, nose, and mouth when removing their cloth face covering and wash hands immediately after removing.

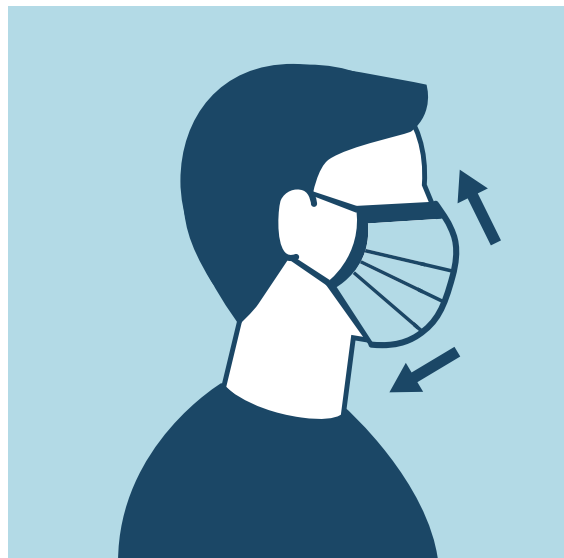

# Sewn Cloth Face Covering

## Materials

- Two 10"x6" rectangles of cotton fabric
- Two 6" pieces of elastic (or rubber bands, string, cloth strips, or hair ties)
- Needle and thread (or bobby pin)
- Scissors
- Sewing machine

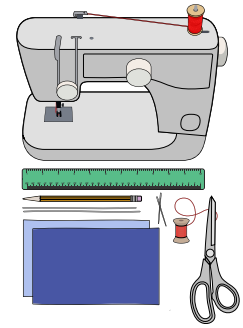

## Tutorial

1. Cut out two 10-by-6-inch rectangles of cotton fabric. Use tightly woven cotton, such as quilting fabric or cotton sheets. T-shirt fabric will work in a pinch. Stack the two rectangles; you will sew the cloth face covering as if it was a single piece of fabric.

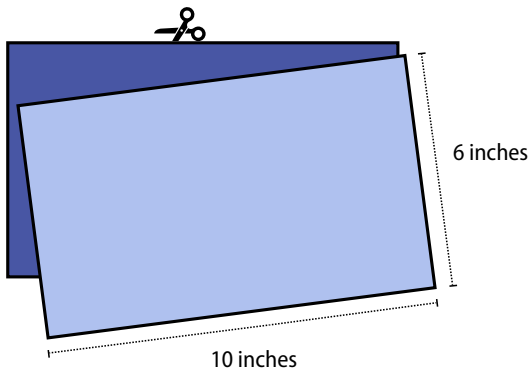

2. Fold over the long sides  $\frac{1}{4}$  inch and hem. Then fold the double layer of fabric over  $\frac{1}{2}$  inch along the short sides and stitch down.

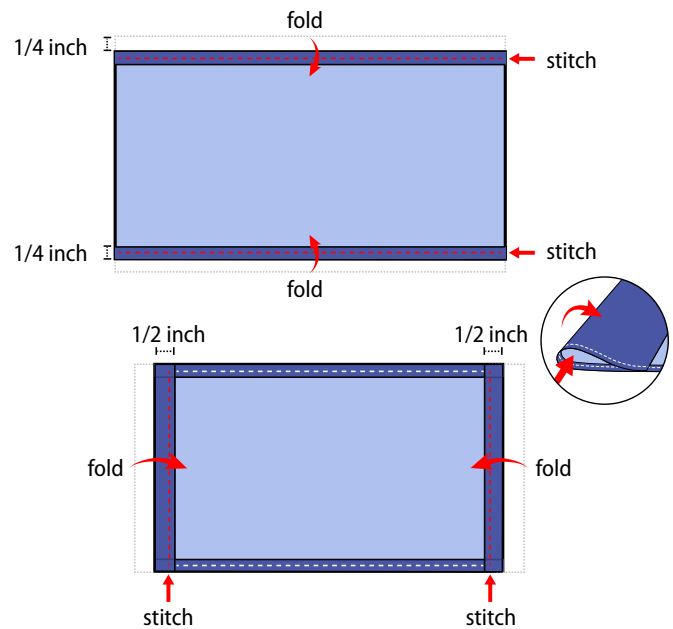

3. Run a 6-inch length of  $\frac{1}{8}$ -inch wide elastic through the wider hem on each side of the cloth face covering. These will be the ear loops. Use a large needle or a bobby pin to thread it through. Tie the ends tight. Don't have elastic? Use hair ties or elastic head bands. If you only have string, you can make the ties longer and tie the cloth face covering behind your head.

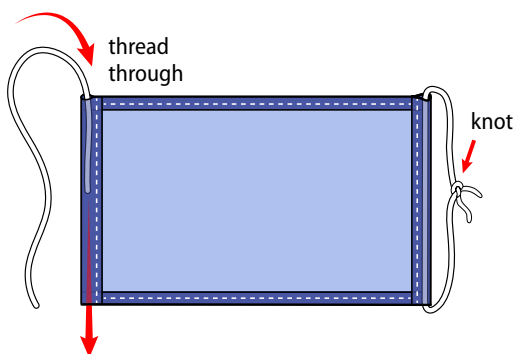

4. Gently pull on the elastic so that the knots are tucked inside the hem. Gather the sides of the cloth face covering on the elastic and adjust so the cloth face covering fits your face. Then securely stitch the elastic in place to keep it from slipping.

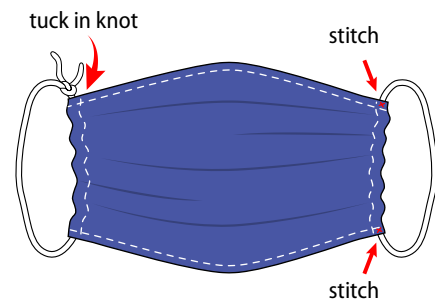

# Quick Cut T-shirt Cloth Face Covering (no sew method)

## Materials

- T-shirt
- Scissors

## Tutorial

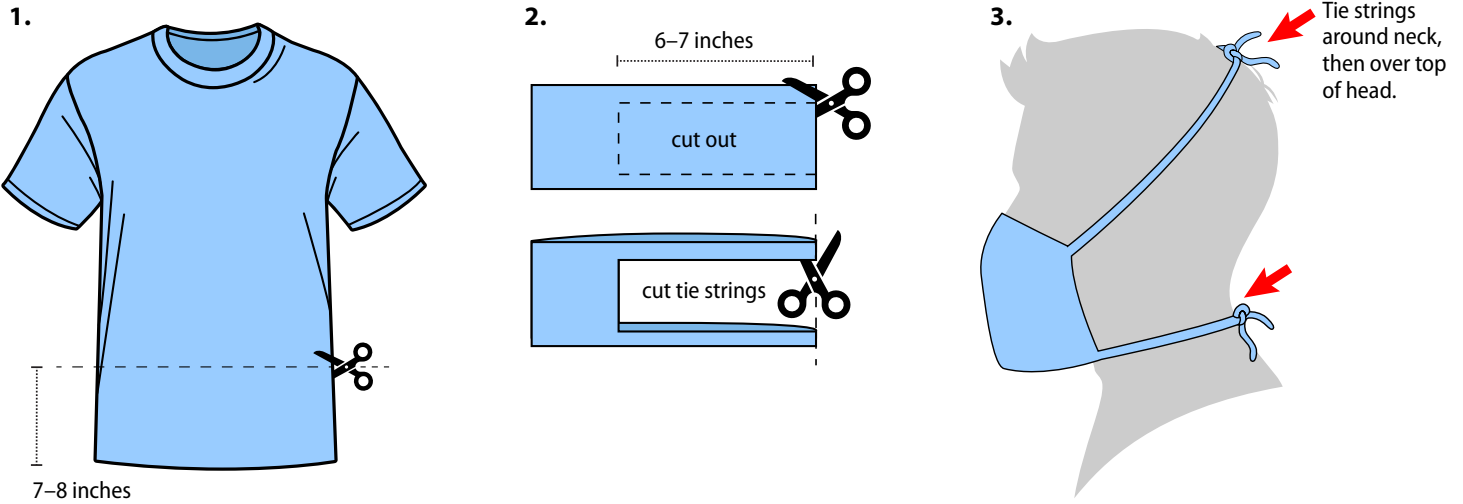

# Bandana Cloth Face Covering (no sew method)

## Materials

- Bandana (or square cotton cloth approximately 20"x20")
- Coffee filter
- Rubber bands (or hair ties)
- Scissors (if you are cutting your own cloth)

## Tutorial

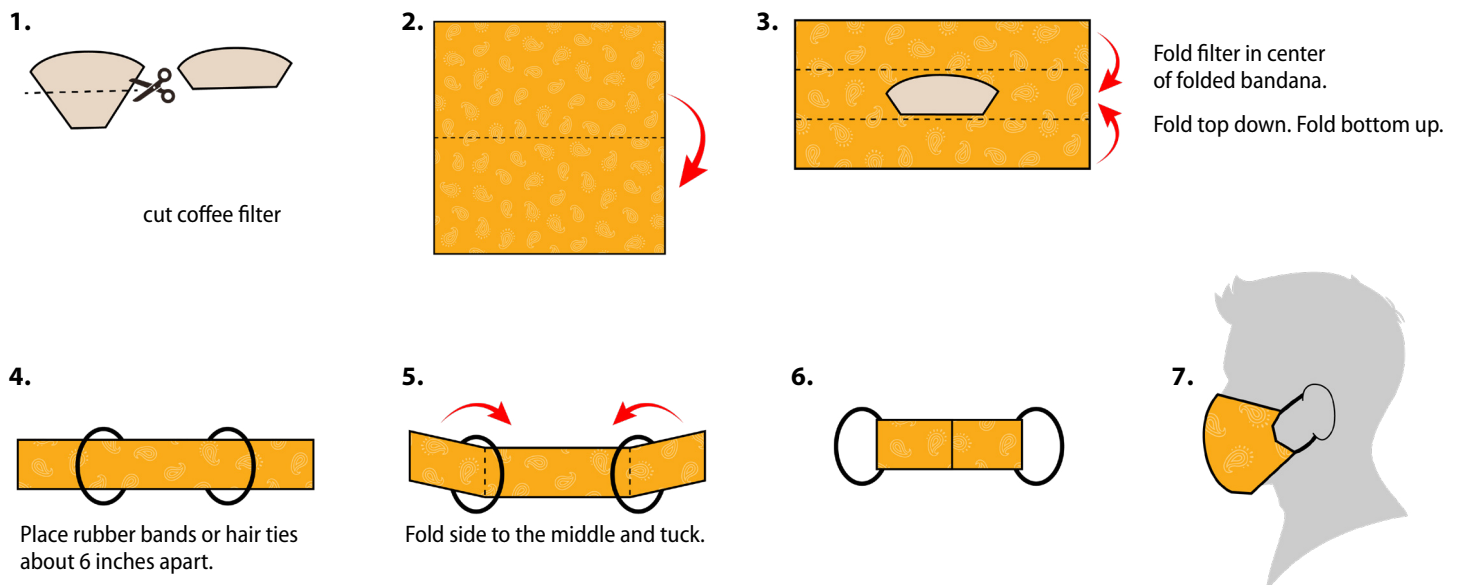

**Site-Specific Health and Safety Plan**  
***The Peninsula Redevelopment Project***  
***1221 Spofford Avenue, Bronx, New York***

---

**APPENDIX H**

Community Air Monitoring Plan (CAMP)



# Project-Specific Community Air Monitoring Plan

---

1221 Spofford Avenue  
Bronx, New York

November 2, 2020

Prepared for:

**The Peninsula JV, LLC**  
7 Jackson Walkway  
Providence, Rhode Island 02903

Prepared by:

**Roux Environmental Engineering  
and Geology, D.P.C.**  
209 Shafter Street  
Islandia, New York 11749

# Table of Contents

1. Introduction .....	1
1.1 VOC Monitoring Approach.....	1
1.2 Particulate Monitoring, Response Levels and Actions .....	2
1.3 Meteorological Monitoring .....	3
1.4 Available Suppression Techniques.....	3
1.5 Reporting.....	3

## Table

1. Action Limit Summary for VOCs and Particulates

## Appendix

- A. Action Limit Report

# 1. Introduction

Roux Environmental Engineering and Geology, D.P.C. (Roux), on behalf of The Peninsula JV, LLC, (the "Volunteer"), has developed a project specific Community Air Monitoring Plan (CAMP), in the event that CAMP implementation is required by the New York State Department of Environmental Conservation (NYSDEC) pending the identification of unexpected contaminated media at 1221 Spofford Avenue (Site) during redevelopment activities.

In accordance with the Site Management Plan (SMP), CAMP will not be implemented during future excavation for redevelopment at the Site. If unknown or unexpected contaminated media identified, including grossly contaminated soil or groundwater, NYSDEC will be notified and the CAMP may be implemented, if deemed appropriate. The CAMP is designed to provide a measure of protection for the downwind community and onsite workers not directly involved with the subject work activities from potential airborne contaminant releases as a direct result of remedial and construction activities. This plan is consistent with the New York State Department of Health's (NYSDOH) Generic Community Air Monitoring Plan guidance document.

The specifics of the CAMP are presented in the following four (4) sections:

- 1.1 VOC Monitoring Approach
- 1.2 Particulate Monitoring Approach
- 1.3 Meteorological Monitoring Approach
- 1.4 Available Suppression Techniques

## 1.1 VOC Monitoring Approach

In the event that CAMP implementation is required by NYSDEC, total VOC concentrations in air will be monitored continuously at a location downwind of the excavation activities during all ground intrusive activities. An upwind monitoring station will be set up adjacent to where the excavation is occurring. The VOC monitoring equipment will be located at temporary monitoring stations that will be established daily based on Site logistics and weather conditions. The monitoring work will be conducted using MiniRAE 3000 (or equivalent) portable VOC monitors, or similar type monitors, for all VOC monitoring. The equipment will be calibrated at least once daily using isobutylene as the calibration gas. One (1) upwind and one (1) downwind monitor will be deployed each day. Each monitoring unit is equipped with an audible alarm to indicate exceedance of the action levels (as defined below and summarized in Table 1).

The equipment is capable of calculating 15-minute running average concentrations, which will be compared to the levels specified below.

- If the ambient air concentration of total VOCs at the downwind perimeter of the Site exceeds 5 parts per million (ppm) above background for the 15-minute average, work activities must be temporarily halted and monitoring continued. If the total organic vapor level readily decreases (per instantaneous readings) below 5 ppm over background, work activities can resume with continued monitoring.
- If the ambient air concentration of total VOCs at the downwind perimeter of the Site persists at levels in excess of 5 ppm over background but less than 25 ppm, work activities must be halted, the source of VOCs identified, suppression techniques employed to abate emissions, and monitoring continued.

After these steps, work activities can resume if the total organic vapor level at the Site perimeter is below 5 ppm over the background concentration for the 15-minute average. If levels are in excess of 25 ppm above background, identified contributing ground-intrusive activities will be halted and vapor suppression techniques will be evaluated and modified until monitoring indicates VOC levels at the Site perimeter are below 5 ppm over background. Once VOC levels are below 5 ppm at the Site perimeter, work will resume with continued monitoring.

All 15-minute readings will be recorded and be available for State Regulator (NYSDEC and NYSDOH) personnel to review. Instantaneous readings, if any, used for decision purposes will be recorded. If an exceedance of the action level occurs, an Action Limit Report (ALR) will be completed, identifying the monitoring device location, the measured VOC level, the activity causing the exceedance, meteorological conditions, and the corrective actions taken, as provided in Appendix A. Additionally, the NYSDEC and NYSDOH will be notified within 24 hours of the VOC ALR generation. Daily monitoring equipment locations and meteorological conditions will also be documented on the daily CAMP Monitoring Location Plan. All documentation will be kept on file at the Site.

## **1.2 Particulate Monitoring, Response Levels and Actions**

In the event that CAMP implementation is required by NYSDEC, particulate concentrations will be monitored continuously at temporary particulate monitoring stations set up at the sidewalk at upwind and downwind locations. The particulate monitoring will be performed using real-time monitoring equipment capable of measuring particulate matter less than 10 micrometers in size (PM-10) and capable of integrating over a period of 15 minutes (or less) for comparison to the airborne particulate action levels (as defined below and summarized in Table 1). Monitoring equipment will be MIE Data Ram monitors or equivalent. A minimum of one (1) upwind and one (1) downwind monitor will be deployed each day, equipped with an omni-directional sampling inlet and a PM-10 sample head. The data logging averaging period will be set to 15-minutes with time and date stamp recording. Alarm averaging will be set at 90 micrograms per cubic meter ( $\mu\text{g}/\text{m}^3$ ) per 15-minute period. This setting will allow proactive evaluation of Site conditions prior to reaching Action Levels of  $100 \mu\text{g}/\text{m}^3$  above background. The equipment will be outfitted with an audible alarm to indicate exceedance of the action level. In addition, fugitive dust migration will be visually assessed during all work activities. The monitoring will be used to compare values to the following:

- If the downwind PM-10 particulate level is  $100 \mu\text{g}/\text{m}^3$  greater than background (upwind perimeter) for the 15-minute period or if airborne dust is observed leaving the Site, then dust suppression techniques must be employed. Work may continue with dust suppression techniques provided that downwind PM-10 particulate levels do not exceed  $150 \mu\text{g}/\text{m}^3$  above the upwind level and provided that no visible dust is migrating from the Site.
- If, after implementation of dust suppression techniques, downwind PM-10 particulate levels are greater than  $150 \mu\text{g}/\text{m}^3$  above the upwind level, work must be stopped, a re-evaluation of activities initiated, and dust suppression techniques modified. Work can resume provided that dust suppression measures and other controls are successful in reducing the downwind PM-10 particulate concentration to within  $150 \mu\text{g}/\text{m}^3$  of the upwind level and in preventing visible dust migration.

All 15-minute readings will be recorded and be available for State Regulator (NYSDEC and NYSDOH) personnel to review. Instantaneous readings, if any, used for decision purposes will be recorded. If an exceedance of the action level occurs, an ALR will be completed, identifying the monitoring device location, the measured particulate concentration, the activity causing the exceedance, meteorological conditions, and the corrective



actions taken, as provided in Appendix A. Daily monitoring equipment locations will also be documented on the daily CAMP Monitoring Location Plan. All documentation will be kept on file at the Site.

### **1.3 Meteorological Monitoring**

Wind speed (estimated) and wind direction, will be approximated based on field observations of onsite personnel. Meteorological data consisting of temperature, barometric pressure, and relative humidity will be recorded in the field book based upon publicly available information from local weather stations.

### **1.4 Available Suppression Techniques**

#### **Odor Control**

Due to the nature of the project, with excavation occurring, the potential for generation of nuisance odors and the need for odor control may be necessary. If nuisance odors are identified, work will be halted and the source of odors will be identified and corrected. Work will not resume until all nuisance odors have been abated. NYSDEC and NYSDOH will be notified of all odor events and of all other complaints about the project.

All necessary means will be employed to prevent on- and off-Site nuisances. At a minimum, procedures will include: (a) limiting the area of open excavations; (b) shrouding open excavations with tarps and other covers; and (c) using foams to cover exposed odorous soils. If odors develop and cannot be otherwise controlled, additional means to eliminate odor nuisances will include: (d) use of chemical odorants in spray or misting systems; and, (e) use of staff to monitor odors in surrounding neighborhoods.

#### **Dust Control**

Due to the nature of the project, the potential for generation of nuisance dust and the need for dust control may be necessary. Dust suppression will be achieved through the use of water for wetting excavation areas, if required. Water will be available on-site at suitable supply and pressure for use in dust control.

### **1.5 Reporting**

All recorded monitoring data will be downloaded and field logged periodically, including action limit reports (if any) and daily CAMP monitoring location plans. All records will be maintained onsite and available for NYSDEC/NYSDOH review. A summary of CAMP findings, including exceedances, will be provided in the Periodic Review Report (PRR). All CAMP monitoring records will be included in the final reporting that will be submitted to the NYSDEC and NYSDOH and will include all of the CAMP data collected, daily monitoring station location maps, and copies of the ALRs (if any). If an ALR is generated due to VOC exceedances, the NYSDEC and NYSDOH will be notified within 24 hours of the exceedance.

**Project-Specific Community Air Monitoring Plan**  
***1221 Spofford Avenue, Bronx, New York***

---

**TABLE**

Action Limit Summary VOCs and Particulates

**Table 1. Action Limit Summary for VOCs and Particulates, Peninsula Redevelopment Project, 1221 Spofford Avenue, Bronx, NY**

Contaminant	Downwind Action Levels*	Action/Response
Volatile Organic Compounds (VOCs) (Monitoring Via Photoionization Detector and Odor Observation)	$< 5 \text{ ppm}$	1. Resume work with continuing monitoring.
	$5 \text{ ppm} < \text{level} < 25 \text{ ppm}$	1. Work activities must be temporarily halted, source vapors must be identified, suppression techniques employed to abate emissions and monitoring continued. 2. After these steps, if VOC levels (200 feet downwind of the exclusion zone or half the distance to the nearest potential receptor or structure, whichever is less) is below 5 ppm over background, resume work.
	$> 25 \text{ ppm}$	1. Identified contributing ground intrusive activities must be halted and vapor suppression techniques must be evaluated and modified until monitoring indicates VOC levels below the action level. 2. After these steps, if VOC levels (half the distance to the nearest potential receptor or structure) are below 5 ppm over background, resume work.
Particulates (Monitoring Via Particulate Meter and Observation)	$< 100 \text{ ug/m}^3$	1. If dust is observed leaving the work area, then dust control techniques must be implemented or additional controls used.
	$100 \text{ ug/m}^3 < \text{level} < 150 \text{ ug/m}^3$	1. Employ dust suppression techniques. 2. Work may continue with dust suppression techniques provided that downwind PM-10 particulate concentration do not exceed $150 \text{ ug/m}^3$ above the upwind level and provided that no visible dust is migrating from the work area.
	$> 150 \text{ ug/m}^3$	1. STOP work 2. Re-evaluate activities, modify dust suppression techniques. Work can resume provided that dust suppression measures and other controls are successful in reducing the downwind PM-10 particulate concentration to within $150 \text{ ug/m}^3$ of the upwind level and in preventing visible dust migration.

\* Instantaneous readings above background. Particulate readings are based on the respirable (PM-10) fraction. Background readings are taken at upwind locations relative to Work Areas or Exclusion Zones.

**Project-Specific Community Air Monitoring Plan**  
**1221 Spofford Avenue, Bronx, New York**

---

**APPENDIX A**

Action Limit Report

**ACTION LIMIT REPORT**

Project Location: Peninsula Redevelopment Project, 1221 Spofford Avenue, Bronx, NY

Date: \_\_\_\_\_ Time: \_\_\_\_\_

Name: \_\_\_\_\_

Contaminant: PM-10: \_\_\_\_\_ VOC: \_\_\_\_\_

Wind Speed: \_\_\_\_\_ Wind Direction: \_\_\_\_\_

Temperature: \_\_\_\_\_ Barometric Pressure: \_\_\_\_\_

DOWNWIND DATA

Monitor ID #: \_\_\_\_\_ Location: \_\_\_\_\_ Level Reported: \_\_\_\_\_

Monitor ID#: \_\_\_\_\_ Location: \_\_\_\_\_ Level Reported: \_\_\_\_\_

UPWIND DATA

Monitor ID #: \_\_\_\_\_ Location: \_\_\_\_\_ Level Reported: \_\_\_\_\_

Monitor ID#: \_\_\_\_\_ Location: \_\_\_\_\_ Level Reported: \_\_\_\_\_

BACKGROUND CORRECTED LEVELS

Monitor ID #: \_\_\_\_\_ Location: \_\_\_\_\_ Level Reported: \_\_\_\_\_

Monitor ID#: \_\_\_\_\_ Location: \_\_\_\_\_ Level Reported: \_\_\_\_\_

ACTIVITY DESCRIPTION

\_\_\_\_\_  
\_\_\_\_\_  
\_\_\_\_\_

CORRECTIVE ACTION TAKEN

\_\_\_\_\_  
\_\_\_\_\_  
\_\_\_\_\_  
\_\_\_\_\_  
\_\_\_\_\_  
\_\_\_\_\_  
\_\_\_\_\_

Site Management Forms

**ROUX ENVIRONMENTAL ENGINEERING AND GEOLOGY, D.P.C.**  
**SITE-WIDE MONITORING, INSPECTION AND MAINTENANCE FORM**

Client: The Peninsula JV, LLC  
Location: 1221 Spofford Avenue, Bronx, New York  
Inspector: \_\_\_\_\_  
Date: \_\_\_\_\_

**Site Observations: Performed by ( ) on ( )**

---

**Yes    No**

- Have any site improvements been made since the last inspection?  
  Has there been any maintenance activity impacting the institutional controls?  
  Are the monitoring wells intact?

-Include sketches or photos of observations.

**Inspection of Property Usage: Performed by ( ) on ( )**

---

**Yes    No**

- Is the property being used for any purposes other than restricted residential, commercial, or industrial use?

-Include sketches or photos of observations.

**Inspection of Groundwater Usage: Performed by ( ) on ( )**

---

**Yes    No**

- Is groundwater underlying the property being used for any purposes including, but not limited to, drinking water or industrial purposes?

-Include sketches or photos of observations.

**Inspection of Remaining Contaminated Material: Performed by ( ) on ( )**

---

**Yes    No**

- Have there been any activities that caused a disturbance of remaining contaminated material since the last inspection?  
  If yes, were the activities conducted in accordance with the Site Management Plan (SMP)?  
If yes, refer to Page 2 for additional clarification..

-Include sketches or photos of observations.

**Inspection of Gardens and Farming: Performed by ( ) on ( )**

---

**Yes    No**

- Is there any evidence of vegetable gardens and/or farming at the property?

-Include sketches or photos of observations.

Include additional information and details on Page 2 of this inspection form if the response to any of the above questions warrants additional explanation.





**Groundwater Gauging THE PENINSULA  
1221 Spofford Avenue, Bronx, New York**

<b>Date</b>	<b>Well</b>	<b>Depth to Product (ft)</b>	<b>Depth to Water (ft)</b>	<b>Well Diameter (inch)</b>	<b>PID (ppm)</b>	<b>Product Thickness (ft)</b>	<b>Purged (g)</b>	<b>Cumulative (g)</b>
	<b>BRMW-1</b>							
	<b>BRMW-2</b>							
							<b>Total</b>	<b>0.00</b>

Notes:

PID - Photo ionization detector (well headspace reading)

ft - Feet

ppm - Parts per million

g - Gallons

ND - Not detected

NG - Not gauged

NM - Not measured

NA - Not applicable



Quality Assurance Project Plan/Field Sampling Plan



# Quality Assurance Project Plan/Field Sampling Plan

---

1221 Spofford Avenue  
Bronx, New York

October 29, 2020

Prepared for:

**The Peninsula JV, LLC**  
7 Jackson Walkway  
Providence, Rhode Island 02903

Prepared by:

**Roux Environmental Engineering  
and Geology, D.P.C.**  
209 Shafter Street  
Islandia, New York 11749

# Table of Contents

1. Introduction .....	1
2. Sampling Objectives .....	2
3. Project Organization.....	3
4. Sample Media, Sampling Locations, Analytical Suites, Sampling Frequency, and Analytical Laboratory .....	4
4.1 Groundwater Sampling.....	4
4.2 Soil Vapor Sampling .....	4
5. Field Sampling Procedures.....	5
5.1 Groundwater Samples.....	5
5.2 Soil Vapor Samples .....	5
6. Sample Handling, Sample Analysis, and Quality Assurance/Quality Control .....	6
6.1 Field Sample Handling .....	6
6.2 Sample Custody Documentation .....	6
6.3 Sample Shipment .....	6
6.4 Quality Assurance/Quality Control .....	7
7. Site Control Procedures and Decontamination.....	9
7.1 Field Work Zones.....	9
7.2 Decontamination.....	9
7.3 Waste Handling and Disposal .....	9

## Tables

1. Field and Quality Control Sampling Summary
2. Field Laboratory Quality Control Summary
3. Preservation, Holding Times, and Sample Containers

## Appendices

- A. Professional Profiles
- B. Roux Standard Operating Procedures
- C. Quality Assurance Glossary

# 1. Introduction

This Quality Assurance Project Plan/Field Sampling Plan (QAPP/FSP) has been prepared to describe the measures that will be taken to ensure that the data generated under the Site Management Plan (SMP) at The Peninsula, located at 1221 Spofford Avenue, Bronx, New York, as enrolled as Site Code C203097 in the New York State Department of Environmental Conservation (NYSDEC) Brownfield Cleanup Program (BCP), herein after referred to as Site, are of quality sufficient to meet project-specific data quality objectives (DQOs).

The Peninsula (Project) has undergone redevelopment and remediation activities, including the demolition of the former Spofford Juvenile Detention Center, remedial excavation, and construction of two buildings, Building 1A and Building 1B. Future development in the near-term at the Site is anticipated to include the construction of two additional residential buildings, Building 2A and Building 2B. The Project consists of the construction of a vibrant live-work campus featuring affordable housing, community space, open/recreational space, industrial space, and retail space. The Site encompasses an area of approximately 3.7348 acres, which has been investigated and remediated under the NYSDEC BCP.

The Peninsula JV, LLC is a Volunteer in the BCP. Any future redevelopment activities completed Post-Certificate of Completion (COC) will be conducted in accordance with the NYSDEC-approved SMP. This QAPP/FSP was prepared in accordance with the guidance provided in NYSDEC Technical Guidance DER-10 (Technical Guidance for Site Investigation and Remediation), 6 NYCRR Part 375, and the United States Environmental Protection Agency's (USEPA's) Guidance for the Data Quality Objectives Process (EPA QA/G-4). This QAPP/FSP provides guidelines and procedures to be followed by field personnel during performance of any investigation or redevelopment activities. Information contained in this QAPP/FSP relates to:

- Sampling objectives (Section 2);
- Project organization (Section 3);
- Sample media, sampling locations, analytical suites, sampling frequencies, and analytical laboratory (Section 4);
- Field sampling procedures (Section 5);
- Sample handling, sample analysis, and quality assurance/quality control (QA/QC) (Section 6); and
- Site control procedures and decontamination (Section 7).

## 2. Sampling Objectives

Roux Environmental Engineering and Geology, D.P.C (Roux) has provided methodology and established sampling objectives for the collection of post-remediation groundwater samples from monitoring wells, and the collection of soil vapor samples and indoor/ambient air samples, as needed, in the event that sampling is required as part of a future Soil Vapor Intrusion (SVI) evaluation. The groundwater sampling and SVI evaluation programs are designed to meet the DQOs set forth in DER-10.

Field sampling procedures are discussed in Section 5 of this QAPP/FSP. A discussion of the DQOs and QA/QC for the Project is provided in Section 6.

### **3. Project Organization**

A general summary of the overall management structure and responsibilities of project team members are presented below. Professional profiles are presented in Appendix A.

#### **Project Principal**

Frank Cherena of Roux will serve as the Project Principal. The Project Principal is responsible for defining project objectives and bears ultimate responsibility for the successful completion of the field work associated with redevelopment.

#### **Remedial Engineer**

I, Brian P. Morrissey, certify that I am currently a NYS registered professional engineer and that this Site Management Plan was prepared in accordance with all applicable statutes and regulations and in substantial conformance with the DER Technical Guidance for Site Investigation and Remediation (DER-10). The Remedial Engineer will certify in the Periodic Review Report (PRR) that the development and sampling activities were completed in accordance with the provisions of the SMP.

#### **Project Manager**

Lauren Dolginko of Roux will serve as the Project Manager. The Project Manager is responsible for defining project objectives and bears ultimate responsibility for the successful completion of the work. This individual will provide overall management for the implementation of the scope of work and will coordinate all field activities. The Project Manager is also responsible for data review/interpretation and report preparation.

#### **Quality Assurance Officer (QAO)**

Dana Hignell of Roux will serve as the QAO. The QAO will review sampling procedures and certify that the data was collected and analyzed using the appropriate procedures. This individual will provide coordination with the analytical laboratory and the data validator to resolve any problems.

#### **Field Analyst**

The Field Analyst will be determined prior to the start of the work. The Field Analyst is responsible for the successful execution of the field program. The Field Analyst will direct the activities of the technical staff in the field, as well as all subcontractors. The Field Analyst also assists in the interpretation of data and in report preparation. The Field Analyst reports to the Project Manager.

#### **Laboratory Project Manager**

The Laboratory Project Manager will be determined prior to the start of the work. The Laboratory Project Manager is responsible for sample container preparation, sample custody in the laboratory, and completion of the required analysis through oversight of the laboratory staff. The Laboratory Project Manager will ensure that quality assurance procedures are followed and that an acceptable laboratory report is prepared and submitted. The Laboratory Project Manager reports to the Field Analyst. The laboratory selected for the redevelopment activities is TestAmerica Laboratories, Inc. of Edison, New Jersey (TestAmerica).

#### **Data Validator**

Joshua Cope of Roux will serve as the Data Validator. The Data Validator is responsible for validation of any sampling data as required by the NYSDEC and preparation of the Data Usability Summary Report (DUSR) in accordance with Appendix 2B of DER-10. Data validation will be completed by a Roux-employed experienced environmental scientist, that is independent from the Project team and will review the analytical data for QA/QC in accordance with NYSDEC standards.



## 4. Sample Media, Sampling Locations, Analytical Suites, Sampling Frequency, and Analytical Laboratory

The media to be sampled during the redevelopment may include groundwater and soil vapor (if necessary). Analytical suites and anticipated frequency for groundwater and soil vapor sampling are provided below and summarized in Tables 1 and 2.

### 4.1 Groundwater Sampling

Post-remediation groundwater samples will be collected from the two bedrock monitoring wells that were installed after completion of the remedial excavation to evaluate the effectiveness of the Remedial Action (RA) during the first two quarters in 2021 following receipt of the COC.

Groundwater samples will be analyzed for the following:

- TCL VOCs.

QA/QC samples, including field duplicate and matrix spike/matrix spike duplicate (MS/MSD) samples, will be collected at a frequency of one per 20 groundwater samples. Trip blank samples will be submitted at a frequency of one per cooler each day groundwater samples are collected for VOC analysis.

Laboratory analyses will be performed by a NYSDOH Environmental Laboratory Approval Program (ELAP)-certified laboratory in accordance with the NYSDEC Analytical Services Protocols (ASP) using USEPA SW-846 Methods. The ELAP-certified laboratory for the redevelopment activities is TestAmerica.

### 4.2 Soil Vapor Sampling

Soil vapor samples may be collected in the event that soil vapor sampling is required as part of a future SVI evaluation.

Soil vapor samples will be analyzed for the following:

- TO-15 VOCs.

QA/QC samples will not be submitted to accompany the soil vapor samples collected.

Laboratory analyses will be performed by a NYSDOH ELAP-certified laboratory in accordance with the NYSDEC ASP using USEPA SW-846 Methods. The ELAP-certified laboratory for the redevelopment activities is TestAmerica.

## 5. Field Sampling Procedures

This section provides a discussion of the field procedures to be used for sampling of groundwater and soil vapor (if necessary).

### 5.1 Groundwater Samples

Groundwater samples will be collected using low stress (low flow) sampling methods. Groundwater parameters will be observed and documented during purging in order to assess water quality prior to sample collection. All groundwater sampling equipment will be properly decontaminated prior to the first use and between each sampling location. Samples will be labeled relative to the bedrock monitoring well they were collected from. Prior to sampling, depth to water will be measured at each well using an electronic water level indicator with an accuracy of  $\pm 0.01$  feet. All wells will then be purged and sampled using a peristaltic, bladder pump, or an alternative method, depending on the observed depth to groundwater and logistical issues. Samples will be analyzed for TCL VOCs. Additional details for the collection of groundwater samples are included in Roux's Standard Operating Procedures (SOPs), included in Appendix B. All groundwater samples will be placed in the laboratory-supplied containers and shipped to the laboratory under chain of custody procedures in accordance with Roux's SOPs.

### 5.2 Soil Vapor Samples

If soil vapor sampling is necessary, the specific depths of the soil vapor samples will be determined in consult with the NYSDEC and the NYSDOH. All soil vapor samples will be collected in accordance with the October 2006 NYSDOH Guidance for Evaluating Soil Vapor Intrusion in the State of New York (NYSDOH Guidance) and analyzed using USEPA Method TO-15 for VOCs.

New Teflon<sup>®</sup>-lined tubing will be attached to an expendable soil vapor sampling point with a 6-inch stainless steel screen inside the rods, to prevent infiltration of ambient air. The soil vapor points will be backfilled with #2 Morie sand to approximately one foot above the screen. The remainder of the borehole will be backfilled with a cement/bentonite slurry to grade.

Prior to sample collection, the Teflon<sup>®</sup>-lined tubing will be purged of approximately two volumes of the tubing using a vacuum pump set at a rate of 0.2 liters per minute. A tracer gas (i.e., helium) will be used to enrich the atmosphere in the immediate vicinity of the sampling location in order to test the borehole seal and verify that ambient air is not being drawn into the sample in accordance with the procedures outlined in the NYSDOH Guidance. Following purging and verification with the tracer gas, the tubing will be connected to the laboratory supplied 6-liter SUMMA canister. All soil vapor samples will be collected using pre-cleaned 2.7-liter summa canisters with regulators calibrated to collect samples over a 2-hour period.

## **6. Sample Handling, Sample Analysis, and Quality Assurance/Quality Control**

To ensure quality data acquisition and collection of representative samples, there are selective procedures to minimize sample degradation or contamination. These include procedures for preservation of the samples, as well as sample packaging, shipping procedures, and QA/QC.

### **6.1 Field Sample Handling**

A detailed discussion of the proposed number and types of samples to be collected during each task, as well as the analyses to be performed can be found in Section 4 and in Tables 1 and 2 of this QAPP/FSP. The types of containers, volumes, holding times, and preservation techniques for the aforementioned testing parameters are presented in Table 3.

### **6.2 Sample Custody Documentation**

The purpose of documenting sample custody is to ensure that the integrity and handling of the samples is not subject to question. Sample custody will be maintained from the point of sampling through the analysis (and return of unused sample portion, if applicable). Specific procedures regarding sample tracking from the field to the laboratory are described in Roux's SOP for Sample Handling, included in Appendix B.

The individual collecting a sample is personally responsible for the care and custody of the samples. All sample labels should be pre-printed or filled out using waterproof ink. The technical staff will review all field activities with the Field Team Leader to determine whether proper custody procedures were followed during the field work and to decide if additional samples are required.

All samples being shipped off-site for analysis must be accompanied by a properly completed laboratory chain of custody form. The sample numbers will be listed on the chain of custody form. When transferring the possession of samples, individuals relinquishing and receiving will sign, date, and note the time on the record. This record documents transfer of custody of samples from the sampler to another person and/or to/from a secure storage area and/or to the shipper, and/or to the laboratory.

Samples will be packaged for shipment and dispatched to the appropriate laboratory for analysis with a separate signed custody record enclosed in each sample box or cooler. Shipping containers will be locked and/or secured with strapping tape in at least two locations for shipment to the laboratory.

### **6.3 Sample Shipment**

Sample packaging and shipping procedures are based upon USEPA specifications, as well as U.S. Department of Transportation (DOT) regulations. The procedures vary according to potential sample analytes, concentration, and matrix and are designed to provide optimum protection for the samples and the public. Sample packaging and shipment must be performed using the general outline described below. Additional information regarding sample handling is provided in Roux's SOP for Sample Handling, included in Appendix B.

All samples will be shipped within 24 hours of collection and will be preserved appropriately from the time of sample collection.

A description of the sample packing and shipping procedures is presented below:

1. Prepare cooler(s) for shipment.
  - Tape drain(s) of cooler shut;
  - Affix "This Side Up" arrow labels and "Fragile" labels on each cooler; and
  - Place mailing label with laboratory address on top of cooler(s).
2. Arrange sample containers in groups by sample number.
3. Ensure that all bottle labels are completed correctly. Place clear tape over bottle labels to prevent moisture accumulation from causing the label to peel off.
4. Arrange containers in front of assigned coolers.
5. Place packaging material approximately at the bottom of the cooler to act as a cushion for the sample containers.
6. Arrange containers in the cooler so that they are not in contact with the cooler or other samples.
7. Fill remaining spaces with packaging material.
8. Ensure all containers are firmly packed with packaging material.
9. If ice is required to preserve the samples, ice cubes should be repackaged in Ziploc® bags and placed on top of the packaging material.
10. Sign chain of custody form (or obtain signature) and indicate the time and date it was relinquished to courier as appropriate.
11. Separate chain of custody forms. Seal proper copies within a large Ziploc® bag and tape to inside cover of cooler. Retain copies of all forms.
12. Close lid and latch.
13. Secure each cooler using custody seals.
14. Tape cooler shut on both ends.
15. Relinquish to overnight delivery service as appropriate. Retain air bill receipt for project records. (Note: All samples will be shipped for "NEXT A.M." delivery.)

## **6.4 Quality Assurance/Quality Control**

The primary intended use for the redevelopment data is to demonstrate that all future sampling completed over the course of the redevelopment is completed in accordance with the NYSDEC-approved SMP. The primary DQO of the sampling, therefore, is that data be accurate and precise, and hence representative of the actual Site conditions. Accuracy refers to the ability of the laboratory to obtain a true value (i.e., compared to a standard) and is assessed through the use of laboratory quality control samples, including laboratory control samples and matrix spike samples, as well as through the use of surrogates, which are compounds not typically found in the environment that are injected into the samples prior to analysis. Precision refers to the ability to replicate a value and is assessed through both field and laboratory duplicate samples.

Sensitivity is also a critical issue in generating representative data. Laboratory equipment must be of sufficient sensitivity to detect target compounds and analytes at levels below NYSDEC standards and

guidelines whenever possible. Equipment sensitivity can be decreased by field or laboratory contamination of samples and by sample matrix effects. Assessment of instrument sensitivity is performed through the analysis of reagent blanks, near-detection-limit standards, and response factors. Potential field and/or laboratory contamination is assessed through use of trip blanks, method blanks, and equipment rinse blanks (also called “field blanks”).

Table 1 lists the redevelopment field and quality control sampling summary. Table 2 lists the field and laboratory quality control samples that will be analyzed to assess data accuracy and precision, as well as to determine if equipment sensitivity has been compromised. Table 3 lists the preservation, holding times, and sample container information.

All groundwater and soil vapor data are to be reported in NYSDEC ASP Category B deliverables, and will be delivered to NYSDEC in electronic data deliverable (EDD) EQUIS format as described on NYSDEC’s website.

A quality assurance glossary is presented in Appendix C.

## 7. Site Control Procedures and Decontamination

Site control procedures have been developed to minimize both the risk of exposure to contamination and the spread of contamination during field activities at the Site. In order to accomplish this objective, this QAPP/FSP addresses three main considerations:

- The establishment of discrete work zones in the redevelopment area;
- The decontamination of field equipment; and
- The disposal of all redevelopment-derived waste.

All personnel who come into designated work areas, including contractors and observers, will be required to adhere strictly to the conditions imposed herein and to the provisions of the consultant's and/or contractor's Site-Specific Health and Safety Plan (HASP), which is included as Appendix H in the SMP.

### 7.1 Field Work Zones

Field work zones will be limited to areas where excavation, stockpiling, and soil sampling is being conducted. Access to these areas will be limited in accordance with the HASP. Control of work zone access will be the responsibility of the individual(s) designated as a Site Health and Safety Manager. At the completion of each working day, all loose equipment (e.g., sampling equipment, coolers, etc.) will be secured. Heavy equipment, such as the excavator, will remain onsite within an established, secured zone.

### 7.2 Decontamination

In an attempt to avoid the spread of contamination, all sampling equipment must be decontaminated at a reasonable frequency. Sampling equipment will be decontaminated prior to use, following collection at each sample location and upon completion of the sampling activities. Temporary decontamination pads or areas will be set up by the contractor as deemed necessary. Detailed procedures for the decontamination of field and sampling equipment are included in Appendix B. The location of the decontamination area(s) will be determined as necessary during the field operations. The decontamination area will be constructed to ensure that any wash water generated during decontamination can be collected and containerized for proper disposal.

### 7.3 Waste Handling and Disposal

All waste materials (e.g., investigation derived waste including drill cuttings, decontamination water, personal protective equipment [PPE], etc.) will be consolidated and stored in appropriate bulk containers (drums, etc.), and temporarily staged at a designated waste storage area. Any full or partially filled containers will be appropriately labeled after the completion of the work. Roux will then coordinate waste characterization and disposal by appropriate means.

**Quality Assurance Project Plan/Field Sampling Plan**  
**1221 Spofford Avenue, Bronx, New York**

---

**TABLES**

1. Field and Quality Control Sampling Summary
2. Field Laboratory Quality Control Summary
3. Preservation, Holding Times, and Sample Containers

**Table 1. Field and Quality Control Sampling Summary**

<b>Sample Medium</b>	<b>Target Analytes</b>	<b>Field Samples</b>	<b>Duplicates<sup>1</sup></b>	<b>Trip Blanks<sup>2</sup></b>	<b>Field Blanks<sup>1</sup></b>	<b>Matrix Spikes<sup>1</sup></b>	<b>Spike Duplicates<sup>1</sup></b>	<b>Total Number of Samples</b>
Groundwater	TCL VOCs	4	1	2	1	1	1	10
Soil Vapor	VOCs	TBD	NA	NA	NA	NA	NA	TBD

Totals are estimated based on scope of work as written, actual sample quantities may vary based on field conditions. QA/QC sample quantities will be adjusted accordingly.

<sup>1</sup> Based on 1 per 20 samples or 1 per Sample Delivery Group (3 days max)

<sup>2</sup> Based on 1 per cooler

NA - Not Applicable

TCL - USEPA Contract Laboratory Program Target Compound List

VOCs - Volatile Organic Compounds



**Table 2. Field and Laboratory Quality Control Summary**

<b>QC Check Type</b>	<b>Minimum Frequency</b>	<b>Use</b>
<u>Field QC</u>		
Duplicate	1 per matrix per 20 samples	Precision
Trip Blank	1 per VOC cooler	Sensitivity
Field Blank	1 per matrix per 20 samples	Sensitivity
<u>Laboratory QC</u>		
Laboratory Control Sample	1 per matrix per SDG*	Accuracy
Matrix Spike/Matrix Spike Duplicate/Matrix Duplicate	1 per matrix per 20 samples	Accuracy/Precision
Surrogate Spike	All organics samples	Accuracy
Laboratory Duplicate	1 per matrix per SDG	Precision
Method Blank	1 per matrix per SDG	Sensitivity

**Notes:**

\* SDG - Sample Delivery Group - Assumes a single extraction or preparation

\*\* Provided to lab by field sampling personnel

**Table 3. Preservation, Holding Times, and Sample Containers**

<b>Analysis</b>	<b>Method</b>	<b>Matrix</b>	<b>Bottle Type</b>	<b>Preservation(a)</b>	<b>Holding Time(b)</b>
VOCs	EPA TO-15	Air	6 liter Summa Canister	NA	30 days from sample collection
TCL VOCs	EPA 8260C	Water	40 mL 3 vov vial, teflon lined cap	Cool to 4°C, Hydrochloric Acid to a pH<2	14 days (preserved)

<sup>(a)</sup> All soil and groundwater samples to be preserved in ice during collection and transport

<sup>(b)</sup> Days from date of sample collection.

TCL - USEPA Contract Laboratory Program Target Compound List

VOCs - Volatile Organic Compounds

NA - Not applicable

**Quality Assurance Project Plan/Field Sampling Plan**  
**1221 Spofford Avenue, Bronx, New York**

---

**APPENDICES**

- A. Professional Profiles
- B. Roux Standard Operating Procedures
- C. Quality Assurance Glossary

**Quality Assurance Project Plan/Field Sampling Plan**  
**1221 Spofford Avenue, Bronx, New York**

---

**APPENDIX A**

Professional Profiles

**TECHNICAL SPECIALTIES**

Project Management and Field Management of Phase I and Phase II Environmental site assessments. GIS data analysis and mapping. Project Management and oversight of remediation and construction activities. Additional experience includes the performance of investigation design and agency correspondence for petroleum and chlorinated solvent remediation projects.

**EXPERIENCE SUMMARY**

Fifteen years of experience: Principal Geologist with Roux Associates, Inc., Islandia, New York; Staff Geologist with RTP Environmental Associates, Inc., Green Brook, New Jersey.

**CREDENTIALS**

B.A., Geology, Colgate University, 2003  
OSHA 40-Hour Hazardous Materials Training, 2003  
OSHA 8-Hour Supervisor Training, 2004  
Accredited AHERA Inspector, 2004  
State of New York Asbestos Inspector Certificate, 2004  
NJ UST Subsurface Evaluator Certification# 491925, 2009

**KEY PROJECTS**

- Principal in charge of large university tech development project in New York City. The project consists of the demolition and decommissioning of a former hospital building, and excavation for redevelopment of four separate buildings for the first phase of campus construction. Environmental considerations on the project included site assessment, remediation design and oversight, SDPES permitting (construction dewatering and geothermal well discharge), soil characterization for reuse and capping of soils. Coordinated with NYCDEP, and other project stakeholders concerning community protection and monitoring concerns.
- Principal in charge of redevelopment of shopping mall in Staten Island, New York. The Site will consist of the construction of two commercial out parcel buildings, a new parking deck, and an expansion of the existing mall building. Areas of concern include historical fill, site-wide soil contamination (arsenic and pesticides). In addition, also responsible for agency coordination with FDNY, NYSDEC, and NYCOER for mitigation of methane and chlorinated volatile organic compounds vapor issues.
- Principal in charge for new development of a large regional mall in Norwalk, Connecticut with underground parking. The proposed redevelopment will result in the construction of a retail shops, restaurants, hotel, and entertainment. Previous usage of the property included over 30 different parcels including three establishments, gasoline filling stations, fuel oil terminal storage, hazardous waste disposal areas. The project includes investigation and subsequent remediation of petroleum and hazardous waste releases, filing of the Environmental Conditions

Assessment Form (ECAAF) associated with the three transfer act parcels

- Project Manager for the largest redevelopment project in New York City (over \$4.5 billion). Project includes Phase I and Phase II ESAs (investigation of soil, groundwater, and soil vapor) at over 75 properties; Construction support for excavation of one million cubic yards of soil including implementing an in situ waste characterization program; Environmental support for demolition, asbestos and lead abatement, site remediation using In Situ Chemical Oxidation, and relocating of an active 9-acre 100-year old railyard; Property acquisition support throughout the project (7 city blocks); and Agency support for NYSDEC, NYCDEP, MTA (LIRR/NYCT), and ESDC. The environmental data was used as an integral component of the New York State Environmental Quality Review Act (SEQRA) final Environmental Impact Statement (EIS). The project will encompass 336,000 sq ft of office space, 6.4 million sq ft of residential space, an 18,000 seat sports and entertainment venue - the Barclays Center (home of the Nets professional basketball team) - 247,000 sq ft of retail space, a 165,000 square-foot hotel, and over 8 acres of intricately designed publicly accessible open space.
- Principal in Charge of numerous due diligence projects for owners, developers, managers, municipalities, and lenders at commercial and industrial properties throughout the Northeast. Activities included performance of UST evaluations and closures, hot spot remediations, Phase I and Phase II Site Assessments, vapor intrusion studies and mitigation, lead based paint, asbestos and hazardous materials surveys, interaction with regulatory agencies on behalf of clients and development of remedial cost estimates for planning and negotiation.
- Principal in Charge for investigation and review of a former electroplating facility in Bay Shore, New York with chlorinated solvent DNAPL. Activities included historical document review, subsurface investigation, and coordination with outside legal counsel and NYSDEC.
- Implemented GIS analysis and mapping for a remedial study and alternative analysis report (AAR) for an active petroleum storage terminal in Buffalo, New York under jurisdiction of the NYSDEC. The AAR required spatial analyses in order to categorize and analyze contaminant data from multiple investigations, investigate remedial alternatives, and to help focus ongoing additional investigations.
- Project manager for a property transfer support project at a heavily contaminated state-of-the-art distribution facility in the Bronx, New York. The site was a former MGP being handled under the VCP in central office, the site had an open spill under the regional spills group

and the site was attempting to apply to the BCP through the regional office. Roux performed a Phase I for the buyer, a Phase II and remedial cost estimate for the owner and negotiated with the buyer's consultant and NYSDEC to limit the scope of the investigation and cleanup.

- Served as Environmental Professional on hundreds of Phase I Environmental Site Assessments according to ASTM E1527-00, ASTM E1527-05, and ASTM E1527-13 for due diligence of large retail shopping centers, industrial facilities, and office buildings. Associated activities included agency contact, database management and interpretation, report preparation, and recommendations for additional work.

**TECHNICAL SPECIALTIES**

- Development, design and implementation of soil and groundwater remediation systems.
- Optimization of ongoing remedial operations.
- Development of project and regulatory closure strategies.
- Management, support, and oversight of large interdisciplinary teams for site remediation.
- Cold eye design review and evaluation of process safety.
- Preparation of feasibility studies, engineer's reports, design drawings, specifications, contract documents, permit applications, cost estimates, operations and maintenance plans and construction management for the following:
  - In situ groundwater remedial technologies
  - Sub-slab depressurization systems
  - Industrial and sanitary wastewater treatment systems
  - Floating product recovery systems
  - Ground water pumping and treatment facilities
  - Water supply, treatment, and distribution
  - Underground storage tank (UST) systems
  - Containment systems
  - Air sparging, soil vapor extraction and vapor collection and treatment systems
  - Building decontamination and decommissioning
  - Landfill cap design and permitting
  - Hazardous waste soils removal, transportation, and disposal

**EXPERIENCE SUMMARY**

Thirty-five years of experience working in many areas of the environmental industry under a variety of regulatory programs such as Federal and State Superfund, New Jersey ECRA/ISRA, NYSDEC Voluntary Cleanup, Petroleum and Chemical Bulk Storage, and NYC Brownfields.

Principal Engineer and Office Manager at Roux Environmental Engineering and Geology, D.P.C.; Senior Engineer and Senior Project Manager at ERM.

**CREDENTIALS**

B.E., Civil Engineering, Cooper Union, 1980  
M.S., Civil and Environmental Engineering, NYU Tandon School of Engineering (former Polytechnic), 1985  
Professional Engineer: New York (1986), New Jersey (2003), and Virginia (2010)  
OSHA 40-hour Health and Safety Training  
ExxonMobil Loss Prevention System certified  
NYCOER Gold Certified Professional  
Board Certified Environmental Engineer (BCEE) of the American Academy of Environmental Engineers and Scientists - Specialty Certification in Hazardous Waste Management, 1995

**PROFESSIONAL AFFILIATIONS**

Water Environment Federation

**KEY PROJECTS**

- Principal Engineer and Project Manager for the remediation and monitoring of over 100 vehicle fueling sites in New York City with UST petroleum releases. The remediation systems at the various sites include multi-phase extraction (MPE), soil vapor extraction (SVE), air sparging, groundwater recovery and treatment, and automated product-only recovery systems. Priorities on this multi-year contract included expediting remedial progress, increasing the effectiveness of operating systems, achieving NFA status, and reducing NYC's overall program costs. The work included conducting soil vapor studies at 9 sites to assess vapor intrusion concerns. Roux Associates also implemented in situ injections at 14 sites to cost-effectively achieve site closure. The in situ injections utilized chemical oxidation and bioremediation products including sodium percarbonate, oxygen generating compounds, hydrogen peroxide, petroleum-degrading bacteria, and nutrient/enzyme complexes.
- Principal Engineer for design upgrades and expansion of the groundwater depression and separate phase product recovery systems at former petroleum refinery in Brooklyn, New York. The site encompasses one of the nation's largest petroleum releases (18 million gallons). Key components included: the installation of 10 remote dual-pump free-phase product recovery wells, including wellhouse/control components and petroleum storage facilities; the construction of extensive underground utilities to connect remote recovery wells with two existing treatment systems; and modifications to existing groundwater treatment facilities to add auxiliary equipment to optimize treatment performance and system runtime. The work also involved the integration of control between the two separate groundwater treatment systems and all associated recovery wells into a single SCADA platform to improve operability. Also, redesigned building with new mezzanine and equipment layout to improve flow of the process treatment train.
- Principal Engineer and P.E. of Record for several Brownfields projects. Responsibilities include development of Remedial Action Work Plan (RAWP), Community Air Monitoring Program (CAMP) and engineering certification of all remediation activities related to management of contaminated soils and clean fill. Also manage designs of remedial elements including sub-slab depressurization systems (SSDS), vapor barriers and waterproofing, stormwater management, and wastewater treatment and disposal.
- Principal Engineer for evaluation and cost estimates of remedial options at a former electronics manufacturing plant in Taiwan. Prepared Pilot Study Plan and presentation for Taiwanese regulatory officials on use of the in situ technologies of enhanced reductive dechlorination and chemical oxidation.

- Principal Engineer for the design of a vapor mitigation system for a 1.5 million square foot warehouse (former aircraft engine manufacturing plant) in New Jersey. The system design includes eight 40-HP blowers and over 600 vapor extraction wells to mitigate elevated levels of chlorinated solvents and petroleum compounds in the subsurface from migrating into the building.
- Principal Engineer for conducting detailed evaluation of problematic groundwater treatment system in Rensselaer, New York. Primary constituents of concern include heavy metals, chlorinated solvents, and BTEX compounds. Developed performance testing program, diagnosed causes of problems and presented several recommendations with cost estimates for upgrading systems and improving personnel health and safety. Prepared engineering report with key recommendations that included modifying equipment layout, injecting iron deposition and calcium scale control agents into water stream, facilitating carbon change-outs and upgrading the system instrumentation and controls.
- Principal Engineer for remediation of former petroleum terminal in Oceanside, New York. Managed preparation of Remedial Action Plan, community air monitoring plan, detailed design drawings, bid documents and O&M Plan. Conducted discussions/negotiations with NYSDEC and managed the annual budget for capital and operating expenses.
- Principal Engineer for the design of a soil vapor extraction (SVE) system to address elevated concentrations of methane and petroleum hydrocarbons in the shallow subsurface beneath three Operable Units of the project area. The major components of the design included the installation of 21 SVE wells and associated piping and instrumentation, the construction of a new treatment building to house the SVE treatment equipment, as well as office space to support the remediation project; and the installation of a thermal/catalytic oxidation system to treat the soil vapor extracted from the SVE wells, and also the air stripping and aeration process streams from a nearby groundwater treatment facility. The SVE treatment system was designed to accept up to 4,000 cfm of process air to meet the discharge requirements of 6 NYCRR, Part 201 and NYSDEC DAR-1 guidelines. All activities were performed under the oversight of the NYSDEC and in compliance with a strict regulatory milestone schedule.
- Senior Manager for Remedial Design and Construction Oversight at federal Superfund site in Elmira, New York. The 33-acre site included several areas of concern where the soil and groundwater had been contaminated by several types of hazardous wastes. Managed preparation of design submittals to USEPA Region II in accordance with CERCLA guidelines. The soil/sediment remediation design included requirements for materials handling, dewatering and disposal. PCB wastes were required to be segregated and disposed of at a TSCA-permitted facility. The design required stabilization of certain wastes and the installation of a RCRA cap. The design included measures for control and treatment of dewatered fluids and stormwater during construction. Groundwater remediation system includes 12 recovery wells, filtration units and two air strippers.
- Principal Engineer and P.E. of Record for the design and construction of a storm drainage and sanitary sewer project located in the area of a former petroleum terminal in Brooklyn, New York. Worked on several design modifications to obtain NYCDEP approvals. Work included construction of approximately 1,600 linear feet of RCP storm sewer and approximately 1,000 feet of ductile iron sanitary sewer with pipe sizes ranging from 12-inch diameter to 54-inch diameter. Also replaced approximately 220 feet of 20-inch cast iron water main. The construction required vibration monitoring during sheeting and operation and maintenance of a temporary dewatering treatment system.
- Project Manager for remediation of several gasoline service station sites in Westchester County and Long Island, New York. Developed design/build approach for fast-track implementation while complying with NYSDEC guidelines. Typical remedial systems include groundwater recovery and treatment, soil vapor extraction and air sparging, and vapor treatment.
- Principal Engineer for an underground utility construction project for the expansion of a large groundwater treatment operation. Project included excavation and installation of over 3,500 linear feet of water main, product pipeline and control conduits within NYC streets.
- Provided engineering evaluation of options for UST repair/replacement at major railroad yard in Sunnyside, Queens, New York to address relocation needs and comply with NYSDEC tank regulations. Worked on preparation of UST upgrade work plan, cost estimates and contract documents.
- Principal Engineer for a building decommissioning and demolition project at an active railroad facility in Sunnyside, Queens, New York. Project included preparation of demolition specifications, collection of waste characterization soil and water samples, air monitoring, removal and disposal of impacted soil, removal and disposal of asbestos containing material, removal and disposal of demolition debris, and preparation of a demolition completion report.
- Project Manager for remediation of industrial airport site in Millville, New Jersey under ECRA/ISRA programs. Managed planning, detailed design and permitting activities required to replace 1,000-gpm public supply well impacted by extensive chlorinated solvent plume. Also managed the conceptual planning, permitting and final design of the 200-gpm groundwater recovery, treatment and recharge system



that includes ultraviolet light/hydrogen peroxide system controlled by PLCs. This project won the annual Honor Award granted by the American Academy of Environmental Engineers and Scientists.

- Project Manager for the design of wastewater treatment plant (WWTP) upgrades at three (3) separate facilities under the program to protect New York City's watershed. The work included preparing conceptual upgrade plans, facility plans, detailed cost estimates, design drawings and specifications, startup plans, O&M plans, and oversight of construction. Design at one facility included replacement of secondary treatment components and the addition of recirculating sand filters, microfiltration units, emergency generator and telemetry systems.
- Design Manager for groundwater recovery and treatment system at a former manufactured gas plant (MGP) in Atlantic Highlands, New Jersey. Developed specification for implementation of directional drilling under state highway to expand groundwater recovery system to capture off-site contamination. Treatment system design included PLC-based control software that significantly reduced on-site staffing needs. Also, managed construction phase, negotiated/reduced change orders and worked with several subcontractors to meet tight regulatory agency schedule for system start-up. The system removes cyanide, metals, VOCs, and free-phase product.
- Project Manager for upgrading industrial process wastewater treatment system at medical products manufacturing facility in Hancock, New York. The upgraded system removes VOCs and metals, including lead, zinc, and copper, from highly variable waste streams generated by the manufacture of surgical instruments. Prepared design documents for automated system that allows for expected future increase in plant manufacturing capabilities. Also, prepared O&M plan for the treatment system.
- Project Manager for tank replacement program and automation of fueling system for commuter railroad at sites in New York City and Westchester County. Fueling facilities were designed in compliance with federal and state UST regulations.
- Senior Engineer for preparing and certifying Spill Prevention Control and Countermeasure (SPCC) Plans for 25 U.S. Postal Service facilities.
- Project Manager for remediation of several US Postal Service sites. Prepared site-specific HASP and Work Plans for removal of USTs and characterization of impacted soils. Supervised field personnel during investigative and construction phases of work. Also, prepared designs for new double-walled UST systems.
- Project Engineer for environmental audits at approximately 20 commercial and manufacturing facilities aimed at evaluating compliance with federal, state, and local air, wastewater, and hazardous waste regulations. Audits addressed regulatory areas including RCRA, SARA, CWA, CAA, TSCA, and OSHA.
- Project Manager for planning, permitting, design and construction oversight of 12,000-foot sewer system for the collection of sanitary and industrial wastewater in Melville, New York. Sewer design included route selection, sizing of gravity sewers, provisions for utility crossings, solar powered flow meters, grease interceptor, pump station for one branch line, and proper abandonment of leaching facilities. Project also included installation of two 20,000-gallon underground storage tanks and a tanker truck fill area with secondary containment. The final phase of the project consisted of the addition of an industrial waste pretreatment system utilizing pH adjustment, filtration, and a bioreactor tank. This project provided a safe and reliable wastewater disposal system and eliminated a costly 40,000-gallon per day hold and haul system.
- Project Manager for the planning and design of irrigation system using treated wastewater in the Catskills area. Conducted study on acceptable uses of wastewater treated by tertiary methods in accordance with federal and New York State guidance.
- Project Engineer, prepared feasibility study for state Superfund site of former manufacturer of printing inks and ribbons in Glen Cove, New York. Elevated levels of toluene, xylenes, ethylbenzene, and benzene were detected in on-site soils above soil cleanup objectives (SCOs) for the protection of groundwater. Evaluated ground water and soil remediation technologies. After approval of FS by NYSDEC, managed the final design, construction oversight, and startup phases of the project. Remedial system included 30 variable speed controlled recovery pumps, filtration, iron sequestration, tray aeration, soil vapor extraction, and vapor treatment via catalytic oxidation.
- Principal Engineer for development of innovative approach for remediation and reuse of federal Superfund site in Plaistow, New Hampshire. Prepared cost estimates for approaches aimed at reducing project costs by utilizing alternate treatment technologies and maximizing efficiency of existing system. Phased approach for site includes hot spot soil removal, enhancements of existing remedial system, implementing air sparging with SVE and follow-up with polishing step of in situ bioremediation. This alternative plan would achieve environmental restoration of site and is tailored to anticipated re-development of land.
- Principal Engineer for the design of modifications to an active sub-slab depressurization system (SSDS) to mitigate chlorinated solvent soil vapor contamination beneath an existing occupied shopping mall in the Bronx, New York. Worked on coordination and troubleshooting of construction issues. Managed the system testing and start-up and provided recommendations to improve system operation.

**TECHNICAL SPECIALTIES**

Design, implementation, and management of Remedial Investigations and Remedial Actions for New York State Department of Environmental Conservation Brownfields Cleanup Program (NYSDEC BCP). Management of due diligence Site Assessments; Preparation and management of Brownfield Cleanup Applications, Remedial Investigation Work Plans, Remedial Investigation Reports, Remedial Action Work Plans, and Remedial Action Reports; Investigation and evaluation of petroleum, polychlorinated biphenyl (PCB), and per- and poly fluoroalkyl substances (PFAS)-related contamination; Management of large-scale soil excavation projects including demolition, waste characterization, and construction activities.

**EXPERIENCE SUMMARY**

Five years of experience: Project Geologist and Staff Geologist, Roux Environmental Engineering and Geology, D.P.C., Islandia, NY

**CREDENTIALS**

M.S. Geology, SUNY Binghamton University, 2014  
B.S. Geology, SUNY Ononota College, 2012  
OSHA 40-Hour HAZWOPER Training, 2014  
OSHA Eight-Hour Refresher Training, 2018  
OSHA Ten-Hour Construction Outreach Training, 2015  
Transportation Worker Identification Credential, 2015  
New York State Builders Association Four-Hour Stormwater Training, 2015

**KEY PROJECTS**

- Project manager for neighboring redevelopment Sites in the NYSDEC BCP, located in Bronx, New York. Responsibilities include the preparation and implementation of NYSDEC-approved investigation work plans and management during construction operations to ensure successful implementation of remedial elements. On-site investigations included hot spot delineation, *in situ* waste characterization sampling, and a NYSDEC Remedial Investigation (including groundwater sampling for emerging contaminants – 1,4-dioxane and PFAAs).
- Project Manager for an affordable housing redevelopment site in the NYSDEC BCP in Bronx, New York. The site was formally used as a juvenile detention center. This project includes a due diligence environmental investigation; remedial investigations (soil, groundwater, and soil vapor); site-wide *in-situ* waste characterization sampling program; a Remedial Action Work Plan; and the management of soil excavations.
- Project manager for soil transfer of over 15,000 cubic yards between Sites in and outside of regulatory agencies. Responsibilities included management and implementation of soil sampling programs in accordance with NYSDEC Part 360 and DER-10, including emerging contaminants (1,4-dioxane and PFAAs).
- Project manager for NYSDEC BCP Site located in Gowanus neighborhood in Brooklyn, New York. Industrial Site history and proximity to Superfund Site Gowanus Canal requires a USEPA-approved remediation. Project includes management and disposal of non-hazardous and TSCA hazardous soil, and oversight of health and safety regulations and contractor during implementation of NYSDEC-approved RAWP.
- Field and remedial construction manager for the largest on-going redevelopment project in New York. Project included subcontractor and health and safety oversight during utility clearance, soil boring installation, and *in-situ* waste characterization sampling. Additional responsibilities consisted of waste disposal and construction management oversight, support for soil excavation, and ensuring compliance with the Site Environmental Management Plan.
- Field manager for environmental subsurface investigation in Enfield, Connecticut. Project responsibilities included managing subcontractors and health and safety oversight during utility clearance; soil boring installation; MIP/CPT soil screening; and groundwater monitoring well installation. Conducted soil sampling and soil lithology classification, groundwater sampling, soil vapor pin installation, and soil vapor sample collection. Office coordination included the creation of soil boring logs using gINT software and assistance with project planning and report preparation.
- Field manager responsible for construction and excavation oversight on Roosevelt Island, New York. Responsibilities included coordination between multiple general contractors and projects by attending weekly construction meetings, excavation support and soil inspection, groundwater dewatering oversight, soil sampling, Community Air Monitoring Plan (CAMP) support, and weekly Stormwater Pollution Protection Plan inspections.
- Field manager for NYS BCP Remedial Investigation in Staten Island, New York. Project responsibilities included health and safety oversight and management of subcontractors during utility clearance, soil boring installation, groundwater monitoring well installation, and soil vapor point installation. Coordinated and completed soil, groundwater, and soil vapor sampling with a team of field staff. Office coordination included the creation of soil boring logs using gINT software and assistance with project planning and report preparation.
- Field manager for *in-situ* waste characterization in Astoria, Queens. Responsibilities included health and safety oversight and management of

subcontractors during utility clearance and soil boring installation. Completed soil lithology classification and collection of waste characterization soil samples.

- Subcontractor oversight for bedrock core drilling for non-aqueous phase liquid (NAPL) delineation in Queens, New York. Oversight included inspection of bedrock cores for primary and secondary fractures, evidence of contamination, and completion of rock quality designation (RQD) calculations. Project also included oversight during grout secant wall containment area to cut off NAPL source area. Secant wall oversight included the implementation of a CAMP; health and safety oversight of worker breathing zone; and inspection of drilling secant wall installation to ensure hydraulic seal.
- Field manager at a 1,300-acre former aluminum smelter site in Columbia Falls, Montana, listed as a Superfund site. Fieldwork required coordination with USEPA and soil sampling.
- Support to Expert Witness for an on-going case between a major insurance carrier and a large multi-national chemical manufacturer. The case involved categorizing past costs of 12 chemical sites across the country. Assisted in the preparation of expert report on behalf of insurance carrier (Defendant). Complaint No. 84 Civ. 1968 (JSR); U.S. District Court, Southern District of New York.

#### TECHNICAL SPECIALTIES

Engineering services for the investigation, design, construction, and operation and maintenance of remedial systems for the treatment of contaminated soil, sediment, and groundwater. Remedial designs have included excavation, groundwater pump and treat systems, air sparging with soil vapor extraction, vapor barriers and sub-slab depressurization systems, and landfill soil cover systems.

#### EXPERIENCE SUMMARY

Over seventeen years of experience: Staff, Project, and Senior Engineer with Roux Associates, Inc.

#### CREDENTIALS

B.S., Chemical Engineering, Cornell University, 2000.

OSHA 40 hour Health & Safety Course, 2000.

OSHA 8-hour Health & Safety Refresher Course, 2000-Present.

#### KEY PROJECTS

- Senior Engineer for the design and implementation of a passive product-recovery system using horizontal recovery wells at a former bus garage in Newark, New Jersey. The remedial action also included excavation and offsite disposal of approximately 7,000 tons of petroleum contaminated soil, and in-situ chemical oxidation to treat residual soil and groundwater contamination.
- Senior Engineering managing the investigation, design and implementation of product-recovery skimming systems for a former petroleum refinery in Queens, New York. Approximately 80,000 gallons of product has been recovered to date.
- Senior Engineer for the design of a sub-slab depressurization system with vapor barrier for the construction of a 19 story residential building in Brooklyn, New York.
- Senior Engineer for the investigation, design and implementation of a soil remediation project at a Former Oil Terminal in Sag Harbor, New York. The remedy completed includes excavation and offsite disposal of approximately 2,000 tons of petroleum contaminated soil in an active roadway surrounded by underground utilities.
- Senior Engineer for the investigation, design, and implementation of a soil remediation project at a 4-acre Former Oil Terminal in Cold Spring Harbor, New York. The remedy completed includes excavation and offsite disposal of approximately 20,000 tons of petroleum contaminated and/or hazardous lead contaminated soil in accordance with the future use of the site under an Environmental Easement. Additional activities completed at the site included asbestos remediation followed by building demolition, UST removal, and cesspool remediation.
- Project Engineer for the complete design for a 9-acre landfill in Rensselaer, New York as part of the

NYSDEC Voluntary Cleanup Program. The design was in accordance with the future use of the Site as a landfill with an integrated wildlife habitat vegetative cap and included hot spot soil excavation and installation of a vegetative cap.

- Project Engineer for the design of a soil and groundwater remediation system for a Former Oil Terminal in Oceanside, New York. A risk-based remedial approach that called for the remediation of “hot spot” source area soils, and mass-reduction of VOCs in groundwater was successfully utilized for the Site. To address the soil contamination in the source areas, “hot spot” soil excavation was completed. A groundwater pump and treat system was designed, constructed, and continues to be operated and maintained to address the VOC contaminants in groundwater. The system consists of 7 recovery wells, an oil/water separator, and a packed column air stripping tower. Over 11 million gallons of groundwater have been recovered and treated.
- Project Engineer for the design and start up of a soil vapor extraction (SVE) and air sparge (AS) system at an 11-acre active Oil Terminal in Glenwood Landing, NY. The system was installed to address soil and groundwater contaminants and consists of 4 horizontal SVE wells and 8 AS wells. The recovered soil vapor is treated by carbon units before being discharged. Approximately 12,000 pounds of hydrocarbon have been recovered since system start up.
- Project Engineer for the design and start up of a soil vapor extraction (SVE) and air sparge (AS) system at an 11-acre active Oil Terminal in Inwood, NY. The system was installed to address soil and groundwater contaminants and consists of 4 vertical SVE wells and 6 AS wells. The recovered soil vapor is treated by carbon units before being discharged. Approximately 32,000 pounds of hydrocarbon have been recovered since system start up.

#### Operation and Maintenance (O&M) Experience:

- \* Project Engineer responsible for the O&M and monitoring of a SVE system and a dual-pump, product-recovery system at an active Oil Terminal in Inwood, New York. O&M activities included system operation and maintenance, performance monitoring, and preparation of quarterly status reports for submission to the NYSDEC. The SVE system consists of 5 SVE wells and was designed, constructed, operated and maintained for a period of approximately 6 years. The SVE system was permanently shut down and this area of the Site is currently in the post-remediation monitoring phase. The dual-pump system, including groundwater and product recovery and packed column air stripping towers, is currently still in operation.
- \* Project Engineer responsible for the operation and maintenance of soil and groundwater remediation systems for an active Oil Terminal in Glenwood

Landing, New York. A groundwater pump and treat system, consisting of 1 recovery well, two packed column air stripping towers, bag filters and granular activated carbon units, has been in operation at the Site to address VOC contaminants in groundwater. In addition, a SVE/AS system, previously installed, was upgraded to further address soil and groundwater contaminants at the Site boundaries. The SVE system consisted of vertical wells in an area of shallow groundwater. The system was upgraded with 7 horizontal wells and an additional 5 AS wells were installed. Following an on-site diesel spill of approximately 5,000 gallons in 2005, free-product recovery efforts were implemented, including removal of saturated soils and installation of a free-product recovery system.

- \* Staff Engineer responsible for the O&M and monitoring of a SVE/AS system for nationwide distribution center in Brooklyn, New York as part of the NYSDEC Voluntary Cleanup Program. O&M activities included system operation and maintenance, performance monitoring, soil gas monitoring, quarterly monitoring, and preparation of quarterly and annual status reports for submission to the NYSDEC. The SVE and AS system consists of 8 SVE wells and 17 AS wells and was designed, constructed, operated and maintained for a period of approximately 3 years. The SVE and AS system is permanently shut down and the Site is currently in the post-remediation monitoring phase.
- \* Staff Engineer responsible for the O&M of a 430-gpm, dual-pump, product-recovery system in Greenpoint, Brooklyn, New York. Processes and system maintained include dual-pump ground-water and product recovery, low profile air strippers and a catalytic oxidation unit. The Site encompasses one of the nation's largest petroleum releases (18 million gallons).

**UST Experience:**

- \* Project Engineer for the management of the excavation and removal of a 10,000-gallon UST and four ASTs ranging from 284,000-gallon capacity to 976,000-gallon capacity at a former Oil Terminal in Cold Spring Harbor, New York. The scope of work entailed preparation of a UST and AST closure work plan, project management of the field work, post-excavation and tank footprint sampling and preparation of a UST and AST Closure Report.
- \* Project Engineer for the excavation oversight of a 2,000-gallon heating oil UST at an active Oil Terminal in Glenwood Landing, New York. Field oversight included post-excavation and waste characterization soil sampling, health and safety monitoring, supervision during the removal, cleaning, and disposal of the USTs and preparation of a Closure Report.
- \* Project Engineer for the excavation oversight of a 2,000-gallon heating oil UST at an active Oil Terminal in Inwood, New York. Field oversight included post-excavation and waste characterization soil sampling,

health and safety monitoring, supervision during the removal, cleaning, and disposal of the USTs and preparation of a Closure Report. Also included was the management and field oversight of the closure of an in ground oil/water separator at an active Oil Terminal Inwood, New York. The scope of work entailed preparation of an oil/water separator closure work plan, project management of the field work, excavation of petroleum contaminated soils associated with the separator, post-excavation sampling, and preparation of an Oil/Water Separator Closure Report.

- \* Staff Engineer for the excavation oversight of three 8,000-gallon USTs, two pump islands and three hydraulic lifts and all associated piping at a former service station in Norwalk, Connecticut. Field oversight included post-excavation and waste characterization soil sampling, health and safety monitoring, supervision during the removal, cleaning, and disposal of the USTs and preparation of a Closure Report.
- \* Staff Engineer for the excavation oversight of three 8,000-gallon USTs, two pump islands and all associated piping at a former service station in Hartford, Connecticut. Field oversight included post-excavation and waste characterization soil sampling, health and safety monitoring, supervision during the removal, cleaning, and disposal of the USTs and preparation of a Closure Report.

**Soil and Groundwater Remediation:**

- \* Project Engineer for the design of soil remediation at an active Oil Terminal in Stamford, Connecticut to remove contaminated soils following a 30,000-gallon petroleum spill in 2006. The remediation included excavation of approximately 1,000 cubic yards of petroleum-impacted soil with post-excavation sampling.
- \* Staff Engineer responsible for construction management of remediation of a former major pharmaceutical plant located in Hicksville, New York as part of the State Superfund Program. The project consisted of the excavation of non-hazardous soil from 5 on-site drywells and a former waste disposal area, implementation of a community air monitoring plan, coordination with the Long Island Rail Road (LIRR) for work performed within the LIRR's right of way, steel sheeting installation and removal, backfilling, monitoring well abandonment and replacement, transportation and disposal of 3,300 tons of VOC, SVOC and metal contaminated soil, and restoration of approximately 9,800 square feet of asphalt. A 7-foot diameter steel caisson was used to support the deeper excavation required at the invert of two drywells. This innovative approach saved the client approximately \$50,000 in costs that would have been incurred by using a traditional steel sheeting support system to protect the on-site commercial building.

**Stormwater:**

- \* Project Engineer for the design and construction management of a stormwater drainage upgrade project for the parking lot of a former manufacturing facility (costume jewelry and then surgical needles) located in Queens Village, New York. The stormwater drainage system consisted of multiple catch basins, a new drain and curb, and all associated piping.
  
- \* Project Engineer for the design and construction of two stormwater management ponds and swales for a former landfill in Rensselaer, New York. The ponds and swales were constructed as part of the landfill cap project to direct stormwater to existing catch basins, allow stormwater overflow control and to enhance the wildlife habitat.

**TECHNICAL SPECIALTIES**

Fuel oil forensics and age dating, USEPA Superfund, OPA, and NJDEP environmental regulations, Site Assessment and Contractor Oversight, GC/MS Operator, Data Validation, Technical Report preparation and review, Field Chemistry: field screening, HAZCATTING, groundwater and soil sampling, Hazardous Waste Transportation and Disposal

**EXPERIENCE SUMMARY**

25 years experience; Senior Scientist with Roux Associates, Inc.; Senior Chemist, Project Manager with Tetra Tech, Inc.; Owner of Geodyne Engineering Consultants, Inc.; Quality Assurance Officer, GC/MS Operator, Twenty First Century Environmental, Inc.; Project Manager, Field Technician, Resource Applications, Inc.

**CREDENTIALS**

B.A., 1991, Chemistry, Haverford College  
OSHA 40-Hour Health and Safety Training  
Level A Personal Protective Equipment Training  
DOT and IATA Hazardous Material Shipping Training  
New Jersey Transit (NJT) – Roadway Worker / On Track Protection

**FEDERAL PROGRAMS – CLIENT: USEPA****KEY PROJECTS**

- Provide technical and project management support to USEPA Removal and Remedial Branches in Regions 2, 3, 4 on Superfund and OPA projects.
- Manage and perform phase I and II site assessments, remedial investigations, removal action oversight, prepare health and safety plans, monitor site health and safety, support USEPA enforcement actions, implementation of Facility Response Plan (FRP) program, emergency response, biowatch exercises, criminal investigation support, contractor oversight, cost tracking, documentation, daily reporting, prepare after action reports, data validation, waste management, and attend public meetings
- Sites include: UST, AST, and pipeline leaks, lead smelter sites, wood treatment facilities, coal to gas plants, dry cleaners, junk yards, federal facilities, unpermitted landfills, drum burial, flood and hurricane clean up, oil refinery inspections, farmland, and historic industrial sites.
- Contaminants include: TCE, PCE, MTBE, BTEX, oil, gasoline, PCP, PAHs, mercury, lead, arsenic, ammonia, acids, bases, pesticides, PCBs, asbestos, and unknowns.
- Participated in the largest USEPA sponsored interagency response emergency response exercise, Liberty Radex, in Philadelphia. Acted as planner prior to the exercise and master controller during the exercise.
- Interface with state and local regulators on sites in Pennsylvania, Delaware, New Jersey, Maryland, Virginia, West Virginia, and Mississippi.

**STATE PROGRAMS – CLIENTS: BUSINESSES AND INDIVIDUALS IN NEW JERSEY**

- Provide a wide array of environmental services to homeowners, land developers, insurance companies, gas stations, and small industrial companies in New Jersey.
- Manage and/or perform ISRA reporting, phase I and II site assessments, third party investigations, subsurface evaluation, UST removal, air emissions permitting preparation, soil, groundwater, and vapor intrusion investigations, NPDES compliance.
- Manage remedial investigation, design, and execution for LUSTs, and farmland development.
- Manage reporting, deed restriction preparation, CEAs, remedial action permits, and response action outcome preparation (RAO).
- Evaluate environmental costs for insurance claims and litigation cases.
- Prepare and present justification for fine reduction to state regulators for private client.
- Meet with clients, prepare proposals, and negotiate contracts.

**DATA VALIDATION/LABORATORY EXPERIENCE**

- Perform level 3 and 4 data validation of analytical data packages in accordance with USEPA National Functional Guidelines.
- Quality assurance officer and GC/MS operator for New Jersey certified laboratory.
- Performed analysis of volatile and semi-volatile organics.
- Performed maintenance and repair of analytical instruments.
- Performed method development and trouble shooting of analytical issues.
- Set up and operated mobile laboratory for organic and inorganic analyses on Superfund site assessments.
- Performed field screening of contaminants using test kits, XRF, radiation meters, and various types of air monitoring equipment.

**WASTE MANAGEMENT**

- Waste Management Specialist for oil pipeline client in Michigan for largest inland oil spill in United States during August 2010 through October 2011.
- Responsible for compliance, cost tracking, cost estimation, waste tracking and reporting, oil recovery calculation and reporting, contractor oversight.
- Prepared Waste Transportation and Disposal Plans and responses to regulator comments.

- Prepared waste profiles, negotiated waste removal protocols with USEPA and MDEQ to streamline process of waste handling to realize savings through greater efficiency and lowering sampling requirements.
- Located disposal facilities, negotiated disposal rates.
- Performed cost benefit analysis of various soil dewatering agents and procedures and proposed methods and protocols to client, USEPA, and MDEQ.
- Performed some oversight of removal actions along river.
- Supported submerged oil assessment of river.



**Quality Assurance Project Plan/Field Sampling Plan**  
**1221 Spofford Avenue, Bronx, New York**

---

**APPENDIX B**

Roux Standard Operating Procedures

Date: May 5, 2000

---

## 1.0 PURPOSE

The purpose of this standard operating procedure (SOP) is to explain the quality control (QC) measures taken to ensure the integrity of the samples collected and to establish the guidelines for the collection of QC samples. The objective of the QC program is to ensure that water-quality data of known and reliable quality are developed.

Because valid water-chemistry data are integral to a hydrogeologic investigation that characterizes water-quality conditions, the data will be confirmed by QC samples. Without checks on the sampling and analytical procedures, the potential exists for contradictory or incorrect results. The acceptance of water-quality data by regulatory agencies and in litigation-support investigations depends heavily on the proper QC program to justify the results presented. The QC sampling requirements must be determined by the project manager and be clearly defined in the work plan. If data validation (for in-house purposes or for compliance with the United States Environmental Protection Agency [USEPA] regulations) is stipulated as part of the hydrogeologic investigation, QC sampling must be conducted.

## 2.0 QUALITY CONTROL SAMPLES

2.1 Samples taken for analysis of compounds require the use of quality control samples to monitor sampling activities and laboratory performance. Types of quality control samples may include replicate and/or replicate split, trip blank, field equipment blank, matrix spike and matrix spike duplicate, and fortification. A discussion pertaining to each quality control sample follows:

- a. Replicate and Replicate Split - Replicate sample analysis is done to check on the reproducibility of results either within a laboratory or between laboratories. A replicate sample is called a split sample when it is collected with or turned over to a second party (e.g., regulatory agency, consulting firm) for an independent analysis. Replicate samples are aliquots (equal portions) from a sample in a common container.

To collect a replicate sample, water from the bailer or pump will be distributed first to fill one container and then to fill the second container. Adequate water should be available to fill the bottles completely before they are capped. If the water is insufficient to fill all the bottles at once, then incrementally fill each bottle with water from two or more bailer volumes or pump cycles.

For some test substances, water may have to be accumulated in a common container and then decanted slowly into the sample bottles. The work plan should be checked for a description of how replicate samples are to be collected. Additionally, in the case of wells that recover slowly and produce insufficient water to fill all the replicate sample containers, the

containers should be filled incrementally and kept on ice in the cooler in between filling periods.

- b. Trip Blank - A trip blank sample is a sample bottle that is filled with "clean" (e.g., distilled/deionized) water in the laboratory, and travels unopened with the sample bottles. (The USEPA now uses the phrase "demonstrated analyte free water.") It is opened in the laboratory and analyzed along with the field samples for the constituent(s) of interest to detect if contamination has occurred during field handling, shipment, or in the laboratory. Trip blanks are primarily used to check for "artificial" contamination of the sample caused by airborne volatile organic compounds (VOCs) but may also be used to check for "artificial" contamination of the sample by a test substance or other analyte(s). One trip blank per cooler containing VOC samples, or test substance of other analyte(s) of interest would accompany each day's samples.
- c. Field Equipment Blank - A field equipment blank (field blank) sample is collected to check on the sampling procedures implemented in the field. A field blank is made with "clean" (e.g., distilled/deionized/demonstrated analyte free) water by exposing it to sampling processes (i.e., the clean water must pass through the actual sampling equipment). For example, if samples are being collected with a bailer, the field blank would be made by pouring the clean water into a bailer which has been decontaminated and is ready for sampling, and then pouring from the bailer into the sample containers. If a metals equipment blank is to be made, and the water was filtered, then the sample must be filtered (i.e., exposed to the sampling process). One equipment blank would be incorporated into the sampling program for each day's collection of samples and analyzed for the identical suite of constituents as the sample. In some situations one equipment blank will be required for each type of sampling procedure (e.g., split-spoon, bailer, hand auger).

A special type of field blank may be needed where ambient air quality may be poor. This field blank sample would be taken to determine if airborne contaminants will interfere with constituent identification or quantification. This field blank sample is a sample bottle that is filled and sealed with "clean" (e.g., distilled/deionized/demonstrated analyte free) water in the analytical laboratory, and travels unopened with the sample bottles. It is opened in the field and exposed to the air at a location(s) to check for potential atmospheric interference(s). The field blank is resealed and shipped to the contract laboratory for analysis.

- d. Matrix Spike and Matrix Spike Duplicate - Spikes of compounds (e.g., standard compound, test substance, etc.) may be added to samples in the laboratory to determine if the ground-water matrix is interfering with constituent identification or quantification, as well as a check for systematic errors and lack of sensitivity of analytical equipment. Samples

for spikes are collected in the identical manner as for standard analysis, and shipped to the laboratory for spiking. Matrix spike duplicate sample collection, and laboratory spiking and analysis is done to check on the reproducibility of matrix spike results.

- e. Fortification - A fortification, which is performed in the field, is used to check on the laboratory's ability to recover the test substance (analyte) added as well as its stability between fortification and analysis.

A field fortification (spike) is prepared by filling the container(s) with field or distilled/deionized/demonstrated analyte free water (as specified by the laboratory) to a predetermined volume (as specified by the laboratory) and adding the spike (supplied by the laboratory). The predetermined volume of water is measured with a clean (decontaminated) graduated cylinder. Field spikes will be prepared following the collection, labeling, and sealing of nonspiked samples in a separate cooler. The spike is kept at a safe distance from the sampling point (e.g., in the hotel room).

- 2.2 The work plan must be referred to for details regarding the type of QC samples to be collected and the QC sample collection method.

### 3.0 PROCEDURE

- 3.1 Implement QC sampling as outlined above, depending on the type of QC sample(s) specified in the work plan.
- 3.2 Ensure unbiased handling and analysis of replicate and blank QC samples by concealing their identity by means of coding so that the analytical laboratory cannot determine which samples are included for QC purposes. Attempt to use a code that will not cause confusion if additional samples are collected or additional monitoring wells are installed. For example, if there are three existing monitoring wells (MW-1, 2 and 3), do not label the QC blank MW-4. If an additional monitoring well were installed, confusion could result.
- 3.3 Label matrix spike and field fortification (spike) QC samples so that the analytical laboratory knows which samples are to be spiked in the laboratory and which samples were fortified (spiked) in the field, respectively. In certain situations, the field fortification will be "blind" or undisclosed to the laboratory to independently verify their analytical ability.
- 3.4 Verify that each sample is placed in an individual "zip-lock" bag, wrapped with "bubble wrap," and placed in its appropriate container (holder) in the cooler, and that the cooler has sufficient ice (wet ice or blue packs) to preserve the samples for transportation to the analytical laboratory. Consult the site work plan to determine if a particular ice is specified as the preservative for transportation (e.g., the USEPA prefers the use of wet ice because they claim that blue ice will not hold the samples at 4° Centigrade/Celsius).

- 3.5 Document the QC samples on the appropriate field form and in the field notebook. On the chain-of-custody form, replicate and blank QC samples will be labeled using the codes (Number 3.2, above), and matrix spike and field fortification QC samples will be identified as such (Number 3.3, above).
- 3.6 Follow standard shipping procedures for samples (i.e., retain one copy of the chain-of-custody form, secure the cooler with sufficient packing tape and a custody seal, forward the samples via overnight [express] mail or hand deliver to the designated analytical laboratory preferably within 24 hours but no later than 48 hours after sampling). However, check the site work plan for information on the analyte(s), as some have to be analyzed immediately (e.g., CN).

END OF PROCEDURE

Date: March 4, 2015

---

## 1.0 PURPOSE

The purpose of this standard operating procedure (SOP) is to establish guidelines for sample handling which will allow consistent and accurate results. Valid chemistry data are integral to investigations that characterize media-quality conditions. Thus, this SOP is designed to ensure that once samples are collected, they are preserved, packed and delivered in a manner which will maintain sample integrity to as great an extent as possible. The procedures outlined are applicable to most sampling events and any required modifications must be clearly described in the work plan.

## 2.0 CONSIDERATIONS

Sample containers, sampling equipment decontamination, quality assurance/quality control (QA/QC), sample preservation, and sample handling are all components of this SOP.

### 2.1 Sample Containers

Prior to collection of a sample, considerations must be given to the type of container that will be used to store and transport the sample. The type and number of containers selected is usually based on factors such as sample matrix, potential contaminants to be encountered, analytical methods requested, and the laboratory's internal quality assurance requirements. In most cases, the overriding considerations will be the analytical methodology, or the state or federal regulatory requirements because these regulations generally encompass the other factors. The sample container selected is usually based on some combination of the following criteria:

#### a. Reactivity of Container Material with Sample

Choosing the proper composition of sample containers will help to ensure that the chemical and physical integrity of the sample is maintained. For sampling potentially hazardous material, glass is the recommended container type because it is chemically inert to most substances. Plastic containers are not recommended for most hazardous wastes because the potential exists for contaminants to adsorb to the surface of the plastic or for the plasticizer to leach into the sample.

In some instances, however, the sample characteristics or analytes of interest may dictate that plastic containers be used instead of glass. Because some metals species will adhere to the sides of the glass containers in an aqueous matrix, plastic bottles (e.g., nalgene) must be used for samples collected for metals analysis. A separate, plastic container should accompany glass containers if metals analysis is to be performed along with other analyses. Likewise, other sample characteristics may dictate that glass cannot be used. For example, in the

case of a strong alkali waste or hydrofluoric solution, plastic containers may be more suitable because glass containers may be etched by these compounds and create adsorptive sites on the container's surface.

b. Volume of the Container

The volume of sample to be collected will be dictated by the analysis being performed and the sample matrix. The laboratory must supply bottles of sufficient volume to perform the required analysis. In most cases, the methodology dictates the volume of sample material required to complete the analysis. However, individual laboratories may provide larger volume containers for various analytes to ensure sufficient quantities for duplicates or other QC checks.

To facilitate transfer of the sample from the sampler into the container and to minimize spillage and sample disturbance, wide-mouth containers are recommended. Aqueous volatile organic samples must be placed into 40-milliliter (ml) glass vials with polytetrafluoroethylene (PTFE) (e.g., Teflon™) septums. Non-aqueous volatile organic samples should be collected in the same type of vials or in 4-ounce (oz) wide-mouth jars provided by the laboratory. These jars should have PTFE-lined screw caps.

c. Color of Container

Whenever possible, amber glass containers should be used to prevent photodegradation of the sample, except when samples are being collected for metals analysis. If amber containers are not available, then containers holding samples should be protected from light (i.e., place in cooler with ice immediately after filling).

d. Container Closures

Container closures must screw on and off the containers and form a leak-proof seal. Container caps must not be removed until the container is ready to be filled with the sample, and the container cap must be replaced (securely) immediately after filling it. Closures should be constructed of a material which is inert with respect to the sampled material, such as PTFE (e.g., Teflon™). Alternately, the closure may be separated from the sample by a closure liner that is inert to the sample material such as PTFE sheeting. If soil or sediment samples are being collected, the threads of the container must be wiped clean with a dedicated paper towel or cloth so the cap can be threaded properly.

e. Decontamination of Sample Containers

Sample containers must be laboratory cleaned by the laboratory performing the analysis. The cleaning procedure is dictated by the specific analysis to be performed on the sample. Sample containers must be carefully examined to ensure that all containers appear clean. Do not mistake the preservative as unwanted residue. The bottles should not be field cleaned. If there is any question regarding the integrity of the bottle, then the laboratory must be contacted immediately and the bottle(s) replaced.

f. Sample Bottle Storage and Transport

No matter where the sample bottles are, whether at the laboratory waiting to be packed for shipment or in the field waiting to be filled with sample, care must be taken to avoid contamination. Sample shuttles or coolers, and sample bottles must be stored and transported in clean environments. Sample bottles and clean sampling equipment must never be stored near solvents, gasoline, or other equipment that is a potential source of cross-contamination. When under chain of custody, sample bottles must be secured in locked vehicles, and custody sealed in shuttles or in the presence of authorized personnel. Information which documents that proper storage and transport procedures have been followed must be included in the field notebook and on appropriate field forms.

2.2 Decontamination of Sampling Equipment

Proper decontamination of all re-usable sampling equipment is critical for all sampling episodes. The SOP for Decontamination of Field Equipment and SOPs for method-specific or instrument-specific tasks must also be referred to for guidance for decontamination of various types of equipment.

2.3 Quality Assurance/Quality Control Samples

QA/QC samples are intended to provide control over the proper collection and tracking of environmental measurements, and subsequent review, interpretation and validation of generated analytical data. The SOPs for Collection of Quality Control Samples(SOP-3.1), for Evaluation and Validation of Data (SOP-3.4), and for Field Record Keeping and Quality Assurance/Quality Control (SOP-3.2) must be referred to for detailed guidance regarding these respective procedures. SOPs for method-specific or instrument-specific tasks must also be referred to for guidance for QA/QC procedures.

2.4 Sample Preservation Requirements

Certain analytical methodologies for specific analytes require chemical additives in order to stabilize and maintain sample integrity. Generally, this is accomplished under the following two scenarios:

- a. Sample bottles are preserved at the laboratory prior to shipment into the field.



b. Preservatives are added in the field immediately after the samples are collected.

Many laboratories provide pre-preserved bottles as a matter of convenience and to help ensure that samples will be preserved immediately upon collection. A problem associated with this method arises if not enough sample could be collected, resulting in too much preservative in the sample. More commonly encountered problems with this method include the possibility of insufficient preservative provided to achieve the desired pH level or the need for additional preservation due to chemical reactions caused by the addition of sample liquids to pre-preserved bottles. The use of pre-preserved bottles is acceptable; however, field sampling teams must always be prepared to add additional preservatives to samples if the aforementioned situations occur. Furthermore, care must be exercised not to overfill sample bottles containing preservatives to prevent the sample and preservative from spilling and therefore diluting the preservative (i.e., not having enough preservative for the volume of sample).

When samples are preserved after collection, special care must be taken. The transportation and handling of concentrated acids in the field requires additional preparation and adherence to appropriate preservation procedures. All preservation acids used in the field should be trace-metal or higher-grade.

## 2.5 Sample Handling

After the proper sample bottles have been received under chain-of-custody, properly decontaminated equipment has been used to collect the sample, and appropriate preservatives have been added to maintain sample integrity, the final step for the field personnel is checking the sample bottles prior to proper packing and delivery of the samples to the laboratory.

All samples should be organized and the labels checked for accuracy. The caps should be checked for tightness and any 40-ml volatile organic compound (VOC) bottles must be checked for bubbles. A plastic (garbage) bag should line the inside of the cooler and all ice and samples should be placed inside to prevent leaking during transportation. Each sample bottle must be placed in an individual "zip-lock" bag to protect the label, and placed on ice. The bottles must be carefully packed, preferably with bubble wrap, to prevent breakage during transport. When several bottles have been collected for an individual sample, they should not be placed adjacent to each other in the cooler to prevent possible breakage of all bottles for a given sample. If there are any samples which are known or suspected to be highly contaminated, these should be placed in an individual cooler under separate chain-of-custody to prevent possible cross contamination. Sufficient ice (wet or blue packs) should be placed in the cooler to maintain the temperature at 4 degrees Celsius (°C) until delivery at the laboratory. Consult the work plan to determine if a particular ice is specified as the preservation for transportation (e.g., the United States Environmental Protection Agency does not like the use of blue packs because they claim that the samples will not hold at 4°C). If additional coolers are required, then they should be purchased. The chain-of-custody form should be properly completed, placed

in a "zip-lock" bag, and placed in the cooler. One copy must be maintained for the project files. The plastic (garbage) bag encompassing all samples and ice shall be secured tightly with a zip tie. The cooler should be sealed with packing tape and a custody seal. The custody seal number should be noted in the field book. Samples collected from Monday through Friday will be delivered to the laboratory within 24 hours of collection. If Saturday delivery is not available, samples collected on Friday must be delivered by Monday morning. Check the work plan to determine if certain analytes require a shorter delivery time. If overnight mail is utilized, then the shipping bill must be maintained for the files and the laboratory must be called the following day to confirm receipt.

### 3.0 EQUIPMENT AND MATERIALS

3.1 General equipment and materials may include, but not necessarily be limited to, the following:

- a. Sample bottles of proper size and type with labels.
- b. Cooler with ice (wet or blue pack).
- c. Field notebook, appropriate field form(s), chain-of-custody form(s), custody seals.
- d. Black pen and indelible marker.
- e. Packing tape, large plastic (garbage) bag, zip ties, "bubble wrap", and "zip-lock" bags.
- f. Overnight (express) mail forms and laboratory address.
- g. Health and safety plan (HASP).
- h. Work plan/scope of work.
- i. Pertinent SOPs for specified tasks and their respective equipment and materials.

3.2 Preservatives for specific samples/analytes as specified by the laboratory. Preservatives must be stored in secure, spillproof glass containers with their content, concentration, and date of preparation and expiration clearly labeled.

3.3 Miscellaneous equipment and materials including, but not necessarily limited to, the following:

- a. Graduated pipettes.
- b. Pipette bulbs.
- c. Litmus paper.

- d. Glass stirring rods.
- e. Protective goggles.
- f. Disposable nitrile gloves.
- g. Lab apron.
- h. First aid kit.
- i. Portable eye wash station.
- j. Water supply for immediate flushing of spillage, if appropriate.
- k. Shovel and container for immediate containerization of spillage-impacted soils, if appropriate.

#### 4.0 PROCEDURE

- 4.1 Examine all bottles and verify that they are clean and of the proper type, number, and volume for the sampling to be conducted.
- 4.2 Label bottles carefully and clearly with project name and number, site location, sample identification, date, time, and the sampler's initials using an indelible marker.
- 4.3 Collect samples in the proper manner (refer to specific sampling SOPs).
- 4.4 Conduct preservation activities as required after each sample has been collected. Field preservation must be done immediately and must not be done later than 30 minutes after sample collection.
- 4.5 Conduct QC sampling, as required.
- 4.6 Seal each container carefully and place in an individual "zip lock" bag.
- 4.7 Organize and carefully pack all samples in the cooler immediately after collection (e.g., bubble wrap). Insulate samples so that breakage will not occur.
- 4.8 Complete and place the chain-of-custody form in the cooler after all samples have been collected. Maintain one copy for the project file. If the cooler is to be transferred several times prior to shipment or delivery to the laboratory, it may be easier to tape the chain-of-custody to the exterior of the sealed cooler. When exceptionally hazardous samples are known or suspected to be present, this should be identified on the chain-of-custody as a courtesy to the laboratory personnel.
- 4.9 Add additional ice as necessary to ensure that it will last until receipt by the laboratory.

- 4.10 Seal the cooler with packing tape and a custody seal. Record the number of the custody seal in the field notebook and on the field form. If there are any exceptionally hazardous samples, then shipping regulations should be examined to ensure that the sample containers and coolers are in compliance and properly labeled.
- 4.11 Samples collected from Monday through Friday will be delivered to the laboratory within 24 hours of collection. If Saturday delivery is not available, samples collected on Friday must be delivered by Monday morning. Check the work plan to determine if certain analytes require a shorter delivery time.
- 4.12 Maintain the shipping bill for the project files if overnight mail is utilized and call the laboratory the following day to confirm receipt.

END OF PROCEDURE

Date: May 5, 2000

---

## 1.0 PURPOSE

The purpose for this standard operating procedure (SOP) is to establish the guidelines for purging a well prior to the collection of a ground-water sample. Purging (evacuating) a well involves the removal of the standing column of water in the well to allow "fresh" (representative) formation water to enter the well. Two conventionally used methods for well purging include: 1) discharge of a specified number of casing volumes of water (which is more commonly used); and 2) pumping until specific indicator parameters (e.g., specific conductance, pH, temperature) stabilize. Wells must be purged prior to sampling to ensure the collection of representative formation ground water for water-quality analysis.

For accepted, existing sampling and analysis programs, the same purging method will be used each time to maintain consistency. For new sampling and analysis programs, the basis for the purging technique(s) will be site-specific field conditions, client input, the experience of Roux Associates, Inc. and regulatory agency(ies) guidelines (e.g., some states permit purging a low-yield well to dryness while others insist that some water remains in the well).

## 2.0 EQUIPMENT AND MATERIALS

2.1 The following equipment may be needed to purge a monitoring well before sampling:

- a. Bailers.
- b. Centrifugal pumps.
- c. Electrical submersible pumps.
- d. Peristaltic pumps.
- e. Positive gas-displacement devices.
- f. Bladder pumps.
- g. Hand-operated diaphragm or bilge pump(s).
- h. Teflon™ tape, electrical tape.
- i. Tape measure (stainless steel, steel, fiberglass) with 0.01-foot measurement increments and chalk (e.g., blue carpenter's) or m-scope.
- j. Appropriate discharge hose and valves.

- k. Appropriate discharge tubing (e.g., polypropylene) if using a peristaltic pump.
  - l. Appropriate compressed gas if using bladder-type or gas-displacement device.
  - m. Extension cord(s) or portable generator (and fuel) if using an electric submersible pump.
  - n. Non-absorbent cord (e.g., polypropylene, etc.), cotton (absorbent) cord.
  - o. Tripod(s).
  - p. Water Well Handbook.
  - q. Explosimeter.
  - r. Flow meter.
- 2.2 Bailers or centrifugal pumps are recommended for shallow, small diameter monitoring wells. For deep wells, or large diameter wells, a submersible pump is recommended.

### 3.0 DECONTAMINATION

Each piece of equipment that is used to evacuate wells (e.g., bailers, pumps, hoses) will be decontaminated thoroughly prior to the introduction of the equipment into the well and prior to leaving the site. Additionally, disposable items (e.g., cord, tubing) will be changed between each well purged and discarded in an appropriate manner.

### 4.0 PROCEDURE

- 4.1 The depth to water (DTW) is measured and subtracted from the sounded (total) depth of the well to calculate the length of the column of standing water in the well (in feet).
- 4.2 The volume of the standing water in the well is calculated by multiplying the length of standing water by a coefficient which equates the diameter of the well to gallons per linear foot. (Refer to the attached table from the Water Well Handbook for the coefficient or use the following equation  $[V=(7.48 \text{ gal/ft}^3)(r^2h)]$ , where V is volume of water in gallons, r is the radius of the well casing in feet, and h is the height of the water column in the well in feet].)
- 4.3 If purging is performed by evacuating a specified number of casing volumes, then three to five volumes are purged (typical regulatory agency requirement).
- 4.4 If wells are screened in low permeability formations, then the well may go dry prior to removing the specified volume of water. If the recovery rate is fairly rapid and time allows, then remove more than one casing volume; otherwise, the

evacuation of one casing volume may suffice. (Refer to the site sampling and analysis plan [SAP] for details of purging a low-yield well.)

- 4.5 Evacuation will occur from the top of the water column in the well to ensure that “fresh” formation water enters the bottom of the well through the screen, moves up as standing water is removed from the top, and all standing water is removed (i.e., only representative formation water is in the well).
- 4.6 The volume of water purged from the well must be measured and can be calculated directly by discharging into containers of known volume or can be calculated by multiplying rate of flow by time.
- 4.7 If a submersible or centrifugal pump is used, then the intake is set just below the dynamic (pumping) water level in the well. The rate of flow in gallons per minute (gpm) can be measured using a calibrated bucket (e.g., 5-gallon) if the rate is relatively low, or a 55-gallon drum if the rate is relatively high, and a watch capable of measuring time in second intervals. A precalibrated flow meter may also be used if available.
- 4.8 After the specified number of casing volumes have been evacuated from the well, the pump intake is lifted slowly until it breaks suction to confirm that any standing water above the intake has been purged.
- 4.9 If a bailer is used, then the bailer is lowered only deep enough to remove water from the top of the water column and a 5-gallon bucket is used to measure the volume of water evacuated.
- 4.10 If purging is not executed by evacuating a specified number of well volumes, then purging is performed by pumping or bailing the well until specific indicator parameters (e.g., specific conductance, pH, temperature) stabilize. The volume of water removed is documented on an appropriate field form or in the field notebook.
- 4.11 Water purged from the well will be disposed of in accordance with the appropriate method outlined in the site SAP.
- 4.12 If historic site data indicate that explosive gases could be present and accumulate in the well, then an explosimeter will be used to check vapor concentrations in wells at the site prior to beginning the purging procedure. Vapor concentrations in a well that exceed the 25 percent lower explosive limit (LEL) will require specific precautionary measures to allow purging the well without danger of explosion or fire (e.g., use of cotton cord for bailers or lowering pumping devices, non-electric powered pumps). These conditions will be addressed in the site health and safety plan (HASP) and/or SAP.

END OF PROCEDURE

Date: May 5, 2000

---

## 1.0 PURPOSE

The purpose of this standard operating procedure (SOP) is to establish guidelines for the sampling of ground-water monitoring wells for dissolved constituents. As part of the SOP for the sampling of ground-water monitoring wells, sample collection equipment and devices must be considered, and equipment decontamination and pre-sampling procedures (e.g., measuring water levels, sounding wells, and purging wells) must be implemented. Sampling objectives must be firmly established in the work plan before considering the above.

Valid water-chemistry data are integral to a hydrogeologic investigation that characterizes ground-water quality conditions. Water-quality data are used to evaluate both current and historic aquifer chemistry conditions, as well as to estimate future conditions (e.g., trends, migration pathways). Water-quality data can be used to construct ground-water quality maps to illustrate chemical conditions within the flow system, to generate water-quality plots to depict conditions with time and trends, and to perform statistical analyses to quantify data variability, trends, and cleanup levels.

## 2.0 EQUIPMENT AND MATERIALS

2.1 In order to sample ground water from monitoring wells, specific equipment and materials are required. The equipment and materials list may include, but not necessarily be limited to, the following:

- a. Bailers (Teflon™ or stainless steel).
- b. Pumps (centrifugal, peristaltic, bladder, electric submersible, bilge, hand-operated diaphragm, etc.).
- c. Gas-displacement device(s).
- d. Air-lift device(s).
- e. Teflon™ tape, electrical tape.
- f. Appropriate discharge hose.
- g. Appropriate discharge tubing (e.g., polypropylene, teflon, etc.) if using a peristaltic pump.
- h. Appropriate compressed gas if using bladder-type or gas-displacement device.



STANDARD OPERATING PROCEDURE 4.4  
FOR SAMPLING GROUND-WATER MONITORING  
WELLS FOR DISSOLVED CONSTITUENTS

---

- i. Portable generator and gasoline or alternate power supply if using an electric submersible pump.
- j. Non-absorbent cord (e.g., polypropylene, etc.).
- k. Plastic sheeting.
- l. Tape measure (stainless steel, steel, fiberglass) with 0.01-foot measurement increments and chalk (blue carpenter's).
- m. Electronic water-level indicators (e.g., m-scope, etc.) or electric water-level/product level indicators.
- n. Non-phosphate, laboratory-grade detergent.
- o. Distilled/Deionized water.
- p. Potable water.
- q. Paper towels, clean rags.
- r. Roux Associates' field forms (e.g., daily log, well inspection checklist, sampling, etc.) and field notebook.
- s. Well location and site map.
- t. Well keys.
- u. Stop watch, digital watch with second increments, or watch with a second hand.
- v. Water Well Handbook.
- w. Calculator.
- x. Black pen and water-proof marker.
- y. Tools (e.g., pipe wrenches, screwdrivers, hammer, pliers, flashlight, pen knife, etc.).
- z. Appropriate health and safety equipment, as specified in the site health and safety plan (HASP).
- aa. pH meter(s) and buffers.
- bb. Conductivity meter(s) and standards.
- cc. Thermometer(s).

- dd. Extra batteries (meters, thermometers, flashlight).
- ee. Filtration apparatus, filters, pre-filters.
- ff. Plasticware (e.g., premeasured buckets, beakers, flasks, funnels).
- gg. Disposable gloves.
- hh. Water jugs.
- ii. Laboratory-supplied sample containers with labels.
- jj. Cooler(s).
- kk. Ice (wet, blue packs).
- ll. Masking, duct, and packing tape.
- mm. Chain-of-custody form(s) and custody seal(s).
- nn. Site sampling and analysis plan (SAP).
- oo. Site health and safety plan (HASP).
- pp. Packing material (e.g., bubble wrap)
- qq. "Zip-lock" plastic bags.
- rr. Overnight (express) mail forms.

### 3.0 DECONTAMINATION

- 3.1 Make sure all equipment is decontaminated and cleaned before use (refer to the SOP for Decontamination of Field Equipment for detailed decontamination methods, summaries for bailers and pumps are provided below). Use new, clean materials when decontamination is not appropriate (e.g., non-absorbent cord, disposable gloves). Document, and initial and date the decontamination procedures on the appropriate field form and in the field notebook.
  - a. Decontaminate a bailer by: 1) wearing disposable gloves, 2) disassembling (if appropriate) and scrubbing in a non-phosphate, laboratory-grade detergent and distilled/deionized water solution, and 3) rinsing first with potable water and then distilled/deionized water.
  - b. Decontaminate a pump by: 1) wearing disposable gloves, 2) flushing the pump and discharge hose (if not disposable) first with a non-phosphate, laboratory-grade detergent and potable water solution in an appropriate container (clean bucket, garbage can, or 55-gallon drum) and then with

distilled/deionized water or potable water, and 3) wiping pump-related equipment (e.g., electrical lines, cables, discharge hose) first with a clean cloth and detergent solution and then rinsing or wiping with a clean cloth and distilled/deionized water or potable water.

- 3.2 Note that the decontamination procedures for bailers and pumps are the minimum that must be performed. Check the work plan to determine if chemicals specified by individual state regulatory agencies must also be used for decontamination procedures (e.g., hexane, nitric acid, acetone, isopropanol, etc.).

#### 4.0 CALIBRATION OF FIELD ANALYSIS EQUIPMENT

Calibrate field analysis equipment before use (e.g., thermometers, pH and conductivity meters, etc.). Refer to the specific SOP for field analysis for each respective piece of equipment. Document, and initial and date the calibration procedures on the appropriate field form, in the field notebook, and in the calibration log book.

#### 5.0 PROCEDURE

- 5.1 Document, and initial and date well identification, pre-sampling information, and problems encountered on the appropriate field form and in the field notebook as needed.
- 5.2 Inspect the protective casing of the well and the well casing, and note any items of concern such as a missing lock, or bent or damaged casing(s).
- 5.3 Place plastic sheeting around the well to protect sampling equipment from potential cross contamination.
- 5.4 Remove the well cap or plug and, if necessary, clean the top of the well off with a clean rag. Place the cap or plug on the plastic sheeting. If the well is not vented, allow several minutes for the water level in the well to equilibrate. If fumes or gases are present, then diagnose these with the proper safety equipment. Never inhale the vapors.
- 5.5 Measure the depth to water (DTW) from the measuring point (MP) on the well using a steel tape and chalk or an electronic sounding device (m-scope). Refer to the specific SOPs for details regarding the use of a steel tape or a m-scope for measuring water levels. Calculate the water-level elevation. Document, and initial and date the information on the appropriate field form and in the field notebook.
- 5.6 Measuring the total depth of the well from the MP with a weighted steel tape. Calculate and record the volume of standing water in the well casing on the appropriate field form and in the field notebook.

- 5.7 Decontaminate the equipment used to measure the water level and sound the well with a non-phosphate, laboratory-grade detergent solution followed by a distilled/deionized water rinse.
- 5.8 Purge the well prior to sampling (refer to the SOP for Purging a Well). The well should be pumped or bailed to remove the volume of water specified in the work plan. Usually three to five casing volumes are removed if the recharge rate is adequate to accomplish this within a reasonable amount of time.

If the formation cannot produce enough water to sustain purging, then one of two options must be followed. These include: 1) pumping or bailing the well dry, or 2) pumping or bailing the well to "near-dry" conditions (i.e., leaving some water in the well). The option employed must be specified in the work plan and be in accordance with regulatory requirements.

If the well is purged dry, then all the standing water has been removed and upon recovery the well is ready for sampling. However, depending on the rate of recovery and the time needed to complete the sampling round, one of the following procedures may have to be implemented: 1) the well may have to be sampled over a period of more than one day; 2) the well may not yield enough water to collect a complete suite of samples and only select (most important) samples will be collected; or 3) the well may not recover which will preclude sampling. Regardless of the option that must be followed, the sampling procedure must be fully documented. When preparing to conduct a sampling round, review drilling, development and previous sampling information (if available) to identify low-yielding wells in order to purge them first, and potentially allow time for the well to recover for sampling.

- 5.9 Record the physical appearance of the water (i.e., color, turbidity, odor, etc.) on the appropriate field form and in the field notebook, as it is purged. Note any changes that occur during purging.
- 5.10 If a bailer is used to collect the sample, then:
- a. Flush the decontaminated bailer three times with distilled/deionized water.
  - b. Tie the non-absorbent cord (polypropylene) to the bailer with a secure knot and then tie the free end of the bailer cord to the protective casing or, if possible, some nearby structure to prevent losing the bailer and cord down the well.
  - c. Lower the bailer slowly down the well and into the water column to minimize disturbance of the water surface. If a bottom-filling bailer is used, then do not submerge the top of the bailer; however, if a top-filling bailer is used, then submerge the bailer several feet below the water surface.

- d. Remove and properly discard one bailer volume from the well to rinse the bailer with well water before sampling. Again, lower the bailer slowly down the well to the appropriate depth depending on the bailer type (as discussed above in 5.11 c). When removing the bailer from the well, do not allow the bailer cord to rest on the ground but coil it on the protective plastic sheeting placed around the well. Certain regulatory agencies require that the first bailer volume collected be utilized for the samples.
- 5.11 If a pump is used to collect the sample, then use the same pump used to purge the well and, if need be, reduce the discharge rate to facilitate filling sample containers and to avoid problems that can occur while filling sample containers (as listed in Number 5.14, below). Alternately, the purge pump may be removed and a thoroughly decontaminated bailer can be used to collect the sample.
- 5.12 Remove each appropriate container's cap only when ready to fill each with the water sample, and then replace and secure the cap immediately.
- 5.13 Fill each appropriate, pre-labeled sample container carefully and cautiously to prevent: 1) agitating or creating turbulence; 2) breaking the container; 3) entry of, or contact with, any other medium; and 4) spilling/splashing the sample and exposing the sampling team to contaminated water. Immediately place the filled sample container in a ice-filled (wet ice or blue pack) cooler for storage. If wet ice is used it is recommended that it be repackaged in zip-lock bags to help keep the cooler dry and the sample labels secure. Check the work plan as to whether wet ice or blue packs are specified for cooling the samples because certain regulatory agencies may specify the use of one and not the other.
- 5.14 "Top-off" containers for volatile organic compounds (VOCs) and tightly seal with Teflon™-lined septums held in place by open-top screw caps to prevent volatilization. Ensure that there are no bubbles by turning the container upside down and tapping it gently.
- 5.15 Filter water samples (Procedure 4.6) collected for dissolved metals analysis prior to preservation to remove the suspended sediment from the sample. If water samples are to be collected for total metals analysis, then collect a second set of samples without field filtering.

In the event that the regulatory agency(ies) want unfiltered samples for metals analysis, a second set of filtered samples should also be collected. Because unfiltered samples are indications of total metals (dissolved and suspended) they are not representative of aquifer conditions because ground water does not transport sediment (except in some rare cases). Thus, the results for dissolved metals in ground water should be based on filtered samples even if both filtered and unfiltered sets are presented in a report.

- 5.16 Add any necessary preservative(s) to the appropriate container(s) prior to, or after (preferred), the collection of the sample, unless the appropriate preservative(s) have already been added by the laboratory before shipment.
- 5.17 Collect quality control (QC) samples as required in the work plan to monitor sampling and laboratory performance. Refer to the SOP for Collection of Quality Control Samples.
- 5.18 Conduct field analyses after sample collection is complete by measuring and recording the temperature, conductivity, pH, etc. (as called for in the work plan). Note and record the "final" physical appearance of the water (after purging and sampling) on an appropriate field form and in the field notebook.
- 5.19 Wipe the well cap with a clean rag, replace the well cap and protective cover (if present). Lock the protective cover.
- 5.20 Verify that each sample is placed in an individual "zip-lock" bag, wrapped with "bubble wrap," placed in the cooler, and that the cooler has sufficient ice (wet ice or blue packs) to preserve the samples for transportation to the analytical laboratory.
- 5.21 Decontaminate bailers, hoses, and pumps as discussed in the decontamination SOP. Wrap decontaminated equipment with a suitable material (e.g., clean plastic bag or aluminum foil). Discard cords, rags, gloves, etc. in a manner consistent with site conditions.
- 5.22 Complete all necessary field forms, field notebook entries, and the chain-of-custody forms. Retain one copy of each chain-of-custody form. Secure the cooler with sufficient packing tape and a custody seal.
- 5.23 Samples collected from Monday through Friday will be delivered within 24 hours of collection. If Saturday delivery is not available, samples collected on Friday must be delivered by Monday morning. Consult the work plan to determine if any of the analytes require a shorter delivery time.

END OF PROCEDURE

STANDARD OPERATING PROCEDURE  
FOR SAMPLING AND SCREENING SOIL VAPOR  
MONITORING POINTS

---

Date: January 9, 2011

---

1.0 PURPOSE

The purpose of this standard operating procedure (SOP) is to establish guidelines for the sampling and screening of soil vapor monitoring.

As part of the SOP for the sampling of soil vapor monitoring points, sample collection equipment and devices must be considered, and pre and post-sampling procedures (e.g., purging sample tubing prior to sample collection and screening monitoring point after collection) must be implemented.

Unless otherwise specified in the NYSDEC-approved work plan, all soil vapor sampling will be performed in general accordance with the New York State Department of Health (NYSDOH) Final Guidance for Evaluating Soil Vapor in the State of New York dated October 2006.

2.0 EQUIPMENT AND MATERIALS

2.1 In order to sample the soil vapor monitoring points, specific equipment and materials are required. The equipment and materials list may include, but not necessarily be limited to, the following:

- a. Safety first. Obtain the appropriate Job Safety Analysis (JSA) and personal protection equipment (PPE), as specified in the site Health and Safety Plan (HASP).
- b. Teflon-lined polyethylene tubing.
- c. Master-flex tubing.
- d. Tracer gas (i.e., lab-grade Helium).
- e. Five-gallon plastic bucket.
- f. Vacuum pump with a constant low flow module calibrated to a maximum rate of 0.2 Liters per minute.
- g. Flow meter capable of achieving a flow rate of 0.2 Liters per minute or less.
- h. Watch/Timer.
- i. Appropriate monitoring instruments (e.g., MultiRae, CO<sub>2</sub> and O<sub>2</sub> meters, or equivalent) to measure natural attenuation parameters including volatile organic compounds (VOCs), lower explosive limit (LEL), oxygen, hydrogen sulfide, carbon monoxide and carbon dioxide. LEL will be measured as a percentage of the lower explosion limit for methane (where 100% LEL equals 50,000 ppm of methane), and the remaining parameters

will be measured as percent volume using multi-gas meters calibrated daily with appropriate multi-gas standards.

- j. Calibration gases (isobutylene) and zeroing devices (i.e., air scrubbers)
- k. Roux Associates' soil vapor sampling data form and field notebook.
- l. Plastic sheeting.
- m. Teflon™ tape.
- n. Black pen and water-proof marker.
- o. Tools (e.g., security bolt key, wrenches, screwdrivers, hammer, tubing cutter, etc.) or alternatives recommended in the JSA.
- p. Nitrile and cut-proof gloves.
- q. Laboratory-supplied Summa canister(s) and flow regulator(s).
- r. Chain-of-custody form(s) and custody seal(s).
- s. Field Sampling Plan (FSP) and Quality Assurance Project Plan (QAPP) or equivalent summary.
- t. Site health and safety plan (HASP).
- u. Overnight (express) mail forms.

### 3.0 DECONTAMINATION

3.1 Make sure all equipment is decontaminated and cleaned before use (refer to the SOP for Decontamination of Field Equipment for detailed decontamination methods; a summary for pumps is provided below). Use new, clean materials when decontamination is not appropriate (e.g., disposable gloves, sample tubing). Document, initial and date the decontamination procedures on the appropriate field form and in the field notebook.

- a. Decontaminate a vacuum pump by: disassembling the vacuum pump and cleaning the internal parts with methanol. *Vacuum pumps should not be cleaned in the field.* Vacuum pumps should be decontaminated/cleaned by the facility that supplied/sold the equipment prior to the sampling event.

### 4.0 CALIBRATION OF FIELD ANALYSIS EQUIPMENT

Calibrate field analysis equipment according to manufacturer's manual before use (e.g., MultiRae, CO<sub>2</sub> and O<sub>2</sub> meters). Document, initial and date the calibration procedures on the appropriate field form, and in the field notebook.



## 5.0 PROCEDURE FOR SAMPLING/SCREENING/ SOIL VAPOR MONITORING POINTS

5.1 Soil Vapor Sample Collection Procedures - Soil vapor sampling should be performed in a manner consistent with prior investigations utilizing the following procedural steps:

- 5.1.1 Document, initial and date monitoring point identification, pre-sampling information, and problems encountered on the appropriate field form and in the field notebook, as needed.
- 5.1.2 Inspect the monitoring point sample tubing, and note any items of concern such as missing tubing cap.
- 5.1.3 Place a seal (i.e., model clay) surrounding the sample tubing to further minimize the potential for infiltration of the atmospheric air present at land surface directly above the soil vapor monitoring point (ambient air).
- 5.1.4 Connect the sample tubing to a vacuum pump.
- 5.1.5 Purge the soil vapor sample tubing and the surrounding sand pack of approximately three volumes of air using a vacuum pump set at a rate of approximately but not greater than 0.2 liters per minute.
- 5.1.6 To verify that ambient air is not diluting the soil vapor sample during collection, test monitoring points using a tracer gas (helium), prior to sample collection. Place a plastic container (i.e., bucket) with a seal over the monitoring point and inject helium into the bucket to enrich the interior of the bucket with the tracer gas (this should be done while purging the monitoring point). Measure the rate of helium from the sample tubing as well as the helium-enriched area within the bucket using the Gas Check 3000 (by Ion Science) or equivalent meter. If the screening results show that the rate of helium detected in the sample tubing is greater than 10% of that found in the bucket, reset the seals around the sampling equipment and the sample tubing and purge again. This process of resetting and purging should be continued until the tracer gas is no longer detected at levels greater than 10% of the enriched area.
- 5.1.7 Following the purging and tracer gas verification steps, removed the tubing from the pump, and turn off the pump. Attach the tubing a pre-evacuated Summa canister with a calibrated regulator for sample collection. Use a laboratory supplied calibrated flow controller (2 hour controllers for soil vapor samples and 8 hour controllers for ambient air samples) to restrict the sample collection rate to 0.2 liters per minute or less. The flow controller valve should be closed and sample collection completed when the vacuum reading of the Summa canister reaches -4 inches of mercury (shown on the

flow controller gauge). If the Summa canister vacuum reaches less than 1 inch of mercury, contact the project manager to determine if sample should be analyzed.

- 5.1.8 Once the sample is collected, the soil vapor monitoring point should be screened with several redundant gas meters for the lower explosive limit (LEL), hydrogen sulfide, VOCs, oxygen, carbon monoxide and carbon dioxide. The screening process includes double-checking the screening data through the utilization of separate, redundant gas meters. If there is a discrepancy between the redundant gas meters and any of the screening parameters mentioned above, the meter should be recalibrated according to manufacturer's manual and the soil vapor point should be rescreened. All screening data should be recorded on the appropriate field screening data form and in the field notebook.
- 5.1.9 Collect quality control (QC) samples as required in the work plan to monitor sampling and laboratory performance. One duplicate sample should be collected for every 20 samples. The duplicate sample should be collected immediately after collecting original sample, before screening with redundant gas meters.
- 5.1.10 Upon completion of sample collection and screening steps, cap the sample tubing to allow for subsequent sampling events.
- 5.1.11 Complete all necessary field forms, field notebook entries, and the chain-of-custody form(s). Chain-of-custody form(s) must be signed and dated prior to shipping samples. Retain one copy of each chain-of-custody form. Secure the cooler with sufficient packing tape and a custody seal.
- 5.1.12 Samples collected from Monday through Friday will be delivered within 24 hours of collection. If Saturday delivery is not available, samples collected on Friday must be delivered by Monday morning. Consult the work plan to determine if any of the analytes require a shorter delivery time.

## 6.0 REFERENCES

New York State Department of Health – Guidance for Evaluating Soil Vapor Intrusion in the State of New York, October 2006

END OF PROCEDURE

Date: January 9, 2011  
Revision: May 5, 2015

---

## 1.0 PURPOSE

The purpose for this standard operating procedure (SOP) is to establish the guidelines for decontamination of all field equipment potentially exposed to contamination during field investigation activities (i.e. drilling, soil and water sampling).

The objective of decontamination is to ensure that all field sampling equipment is decontaminated (free of potential contaminants): 1) prior to being brought onsite to avoid the introduction of potential contaminants to the site; 2) between drilling and sampling events/activities onsite to eliminate the potential for cross-contamination between boreholes and/or wells; and 3) prior to the removal of equipment from the site to prevent the transportation of potentially contaminated equipment offsite.

The decontamination line is setup so that the first station is used to clean the most contaminated item. It progresses to the last station where the least contaminated item is cleaned. A site is typically divided up into the following boundaries: Hot Zone or Exclusion Zone (EZ), the Contamination Reduction Zone (CRZ), and the Support or Safe Zone (SZ). The decontamination line should be setup in the Contamination Reduction Corridor (CRC).

In considering decontamination procedures, state and federal regulatory agency requirements must be considered because of potential variability between state and federal requirements. Decontamination procedures must be in compliance with state and/or federal protocols in order that regulatory agency(ies) scrutiny of the procedures and data collected do not result in non acceptance (invalidation) of the work undertaken and data collected.

The equipment and materials list for decontamination activities may include, but not necessarily be limited to, the following:

- a. A work plan and health and safety plan which outlines decontamination procedures and requirements.
- b. Field notebook and field form(s).
- c. Decontamination solutions, including as necessary: non-phosphate, laboratory-grade detergent; distilled/deionized water; potable water; cleaning solvents if needed [e.g., hexane, acetone, nitric acid].
- d. Long and short handled brushes,
- e. Bottle brushes
- f. Drop cloth/plastic sheeting
- g. Paper towels

- h. Plastic or galvanized tubs or buckets
- i. Pressure washers or steam cleaners
- j. Solvent sprayers
- k. Trash / bilge pumps
- l. Aluminum foil
- m. 55-gallon drums.

## 2.0 PROCEDURE FOR DRILLING EQUIPMENT

The following is a minimum decontamination procedure for drilling equipment. Drilling equipment decontamination procedures will be documented on an appropriate field form or in the field notebook, especially any variation from the method itemized below:

- 2.1 Safety first. Obtain the appropriate Job Safety Analysis (JSA) and personal protection equipment (PPE), as specified in the site Health and Safety Plan (HASP). Prior to mobilization to a site, the expected types of contamination should be evaluated to determine if the field cleaning and decontamination activities will generate rinsates and other waste waters that might be considered RCRA hazardous waste or may require special handling.
- 2.2 The drill rig and all associated equipment should be properly decontaminated by the contractor before arriving at the site.
- 2.3 The augers, drilling casings, rods, samplers, tools, and any piece of equipment that can come in contact (directly or indirectly) with the soil, requires proper decontamination on-site prior to commencing drilling. The project work plan or HASP, and appropriate regulatory requirements, should be consulted to determine site-specific decontamination requirements.
- 2.4 The same decontamination procedures used prior to drilling will be followed between boreholes (at a fixed on-site location[s], if appropriate) and before leaving the site at the end of the investigation.
- 2.5 All on-site steam cleaning or (decontamination) activities will be monitored and documented by a member(s) of the staff of Roux Associates, Inc. and should be performed on a decontamination pad that meets the following specifications:
  - 1. The pad should be constructed in an area known or believed to be free of surface contamination.
  - 2. A temporary pad should be lined with a water impermeable material with no seams within the pad. This material should be either easily replaced (disposable) or repairable. The pad should be regularly inspected to ensure there are no leaks.

3. Water should be removed from the decontamination pad frequently.
- 2.6 If drilling activities are conducted in the presence of thick, sticky oils (e.g., PCB oil) which coat drilling equipment, then special decontamination procedures may have to be utilized before steam cleaning (e.g., hexane scrub and wash).
- 2.7 Containment of decontamination fluids may be necessary (e.g., rinseate from steam cleaning) or will be required (e.g., hexane), and disposal must be in accordance with state and/or federal regulatory requirements.

### 3.0 PROCEDURE FOR SOIL-SAMPLING EQUIPMENT

The following is a minimum decontamination procedure for soil-sampling equipment (e.g., split spoons, stainless-steel spatulas). Soil-sampling equipment decontamination procedures, especially any variation from the method itemized below, will be documented on an appropriate field form or in the field notebook.

- 3.1 Safety first. Obtain JSA and PPE, as specified in the site HASP.
- 3.2 Wear disposable gloves while cleaning equipment to avoid cross-contamination and change gloves as needed.
- 3.3 Steam clean the sampler or rinse with potable water. If soil-sampling activities are conducted in the presence of thick, sticky oils (e.g., PCB oil) which coat sampling equipment, then special decontamination procedures may have to be utilized before steam cleaning and washing in detergent solution (e.g., hexane scrub and wash).
- 3.4 Prepare a non-phosphate, laboratory-grade detergent solution and distilled or potable water in a clean bucket.
- 3.5 Disassemble the sampler, as necessary and immerse all parts and other sampling equipment in the solution.
- 3.6 Scrub all equipment in the bucket with a brush to remove any adhering particles.
- 3.7 Rinse all equipment with copious amounts of potable water followed by distilled or deionized water.
- 3.8 Place clean equipment on a clean plastic sheet (e.g., polyethylene)
- 3.9 Reassemble the cleaned sampler, as necessary.
- 3.10 After equipment has been cleaned, all individuals involved in equipment handling should don clean gloves, or wrap the equipment with a suitable material (e.g., plastic bag, aluminum foil).

As part of the decontamination procedure for soil-sampling equipment, state and/or federal protocols must be considered. These may require procedures above those specified as minimum for Roux Associates, Inc., such as the use of nitric acid,

acetone, etc. Furthermore, the containment and proper disposal of decontamination fluids must be considered with respect to regulatory agency(ies) requirements.

#### 4.0 PROCEDURE FOR WATER-SAMPLING EQUIPMENT

The following is a decontamination procedure for water-sampling equipment (e.g., bailers, pumps). Water-sampling equipment decontamination procedures, especially any variation from the method itemized below, will be documented on an appropriate field form or in the field notebook.

4.1 Safety first. Obtain the JSAs and PPE, as specified in the site HASP.

4.2 Decontamination procedures for bailers follow:

- a. Wear disposable gloves while cleaning bailer to avoid cross-contamination and change gloves as needed.
- b. Prepare a non-phosphate, laboratory-grade detergent solution and potable water in a bucket.
- c. Disassemble sampling equipment. Discard all used sampling tubes and cords in an appropriate manner. Disconnect all power sources from electrical equipment (i.e. pumps). Scrub each piece of equipment with a brush and solution.
- d. Rinse all sampling equipment with copious amounts of potable, distilled or deionized water, Reassemble equipment as per the manufacturer's instructions.
- f. Air dry.
- g. Wrap equipment with a suitable material (e.g., clean plastic bag, aluminum foil).

4.3 Decontamination procedures for pumps follow:

- a. Wear disposable gloves while cleaning pump to avoid cross-contamination and change gloves as needed.
- b. Prepare a non-phosphate, laboratory-grade detergent solution and potable water in a clean bucket, clean garbage can, or clean 55-gallon drum.
- c. Flush the pump and discharge hose (if not disposable) with the detergent solution, and discard disposable tubing and/or cord in an appropriate manner.
- d. Flush the pump and discharge hose (if not disposable) with potable water.
- e. Place the pump on clear plastic sheeting.

- f. Wipe any pump-related equipment (e.g., electrical lines, cables, discharge hose) that entered the well with a clean cloth and detergent solution, and rinse or wipe with a clean cloth and potable water.
- g. Air dry.
- h. Wrap equipment with a suitable material (e.g., clean plastic bag).

As part of the decontamination procedure for water-sampling equipment, state and/or federal protocols must be considered. These may require procedures above those specified as minimum for Roux Associates, Inc., such as the use of nitric acid, acetone, etc. Furthermore, the containment and proper disposal of decontamination fluids must be considered with respect to regulatory agency(ies) requirements.

END OF PROCEDURE

**Quality Assurance Project Plan/Field Sampling Plan**  
**1221 Spofford Avenue, Bronx, New York**

---

**APPENDIX C**

Quality Assurance Glossary



## **QUALITY ASSURANCE GLOSSARY**

**"Alteration"** means altering a sample collected for analysis in any way other than by adding a preservative, such as nitric acid to lower pH. Examples of alteration include, but are not limited to: filtering, settling and decanting, centrifuging and decanting and acid extracting.

**"Analytical Services Protocol" or "ASP"** means DEC's compilation of approved EPA laboratory methods for sample preparation, analysis and data handling procedures.

**"Correlation sample"** means a sample taken, when using a field-testing technology, to be analyzed by an ELAP-certified laboratory to determine the correlation between the laboratory and field analytical results.

**"Effective solubility"** means the theoretical aqueous solubility of an organic constituent in groundwater that is in chemical equilibrium with a separate-phase (NAPL) mixed product (product containing several organic chemicals). The effective solubility of a particular organic chemical can be estimated by multiplying its mole fraction in the product mixture by its pure-phase solubility.

**"Environmental Laboratory Accreditation Program" or "ELAP"** means a program conducted by the NYSDOH which certifies environmental laboratories through on-site inspections and evaluation of principles of credentials and proficiency testing. Information regarding ELAP is available at the NYSDOH Wadsworth Laboratory website.

**"Filtration"** means the filtering of a groundwater or surface water sample, collected for metals analysis, at the time of collection and prior to preservation. Filtering includes but is not limited to the use of any membrane, fabric, paper or other filter medium, irrespective of pore size, to remove particulates from suspension.

**"Final delineation sample"** means a sample taken to make a decision regarding the extent of contamination at a site during the investigation and the design of the remedy or confirmation/ documentation sampling during remedial construction, which is to be analyzed by an ELAP-certified laboratory.

**"Intermediate sample"** means a sample taken during the investigation or remediation process that will be followed by another sampling event to confirm that remediation was successful or to confirm that the extent of contamination has been defined to below a level of concern.

**"Method detection limit" or "MDL"** means the minimum concentration of a substance detected and which can be reported with a reasonable degree of accuracy. It is the lowest concentration that can be measured, a lab-specific number, developed from minimum detection limits, and is also referred to as the practical quantitation limit (PQL).

**"Nephelometric Turbidity Unit" or "NTU"** is the unit by which turbidity in a sample is measured.

**"Preservation"** means preventing the degradation of a sample due to precipitation, biological action, or other physical/chemical processes between the time of sample collection and analysis. The most common examples involve refrigeration at 4 degrees Celsius and lowering sample pH by the addition of acid to keep dissolved metals in solution or to reduce the biodegradation of dissolved organic analytes.

**"Target analyte list" or "TAL"** means the list of inorganic compounds/elements designated for analysis as contained in the version of the EPA Contract Laboratory Program Statement of Work for Inorganics Analysis, Multi-Media, Multi-Concentration in effect as of the date on which the laboratory is performing the analysis. For the purpose of this chapter, a Target Analyte List scan means the analysis of a sample for Target Analyte List compounds/elements.

**"Targeted compound"** means a contaminant for which a specific analytical method is designed to detect that potential contaminant both qualitatively and quantitatively.

**"Target compound list plus 30" or "TCL+30"** means the list of organic compounds designated for analysis (TCL) as contained in the version of the EPA Contract Laboratory Program Statement of Work for Organics Analysis, Multi-Media, Multi-Concentration in effect as of the date on which the laboratory is performing the analysis, and up to 30 non-targeted organic compounds (plus 30) as detected by gas chromatography/mass spectroscopy (GC/MS) analysis.

**"Tentatively identified compound or TIC"** means a chemical compound that is not on the target compound list but is detected in a sample analyzed by a GC/MS analytical method. TICs are only possible with methods using mass spectrometry as the detection technique. The compound is tentatively identified using a mass spectral instrumental electronic library search and the concentration of the compound estimated.

**"Well development"** means the application of energy to a newly installed well to establish a good hydraulic connection between the well and the surrounding formation. During development, fine-grained formation material that may have infiltrated the sand pack and/or well during installation is removed, allowing water from the formation to enter the well without becoming turbid and unrepresentative of groundwater in the formation.

IC/EC Certification Form



**Enclosure 2**  
**NEW YORK STATE DEPARTMENT OF ENVIRONMENTAL CONSERVATION**  
**Site Management Periodic Review Report Notice**  
**Institutional and Engineering Controls Certification Form**



**Site Details**

**Site No.**            **C203097**

**Box 1**

**Site Name** **The Peninsula**

Site Address: 1215 & 1221 Spofford Avenue and 720 Tiffany Street      Zip Code: 10474  
 City/Town: Bronx  
 County: Bronx  
 Site Acreage: 3.734

Reporting Period: April 29, 2022 to April 29, 2023

- |  | YES                                 | NO                                  |
|--|-------------------------------------|-------------------------------------|
| 1. Is the information above correct?   | <input checked="" type="checkbox"/> | <input type="checkbox"/>            |
| If NO, include handwritten above or on a separate sheet.   |                                     |                                     |
| 2. Has some or all of the site property been sold, subdivided, merged, or undergone a tax map amendment during this Reporting Period?                              | <input checked="" type="checkbox"/> | <input type="checkbox"/>            |
| 3. Has there been any change of use at the site during this Reporting Period (see 6NYCRR 375-1.11(d))?   | <input type="checkbox"/>            | <input checked="" type="checkbox"/> |
| 4. Have any federal, state, and/or local permits (e.g., building, discharge) been issued for or at the property during this Reporting Period?                      | <input type="checkbox"/>            | <input checked="" type="checkbox"/> |
| <b>If you answered YES to questions 2 thru 4, include documentation or evidence that documentation has been previously submitted with this certification form.</b> |                                     |                                     |
| 5. Is the site currently undergoing development?   | <input checked="" type="checkbox"/> | <input type="checkbox"/>            |

**Box 2**

- |   | YES                                 | NO                       |
|---|-------------------------------------|--------------------------|
| 6. Is the current site use consistent with the use(s) listed below?<br>Restricted-Residential, Commercial, and Industrial | <input checked="" type="checkbox"/> | <input type="checkbox"/> |
| 7. Are all ICs in place and functioning as designed?  | <input checked="" type="checkbox"/> | <input type="checkbox"/> |

**IF THE ANSWER TO EITHER QUESTION 6 OR 7 IS NO, sign and date below and DO NOT COMPLETE THE REST OF THIS FORM. Otherwise continue.**

**A Corrective Measures Work Plan must be submitted along with this form to address these issues.**

\_\_\_\_\_  
 Signature of Owner, Remedial Party or Designated Representative

\_\_\_\_\_  
 Date

**Box 2A**

YES NO

8. Has any new information revealed that assumptions made in the Qualitative Exposure Assessment regarding offsite contamination are no longer valid?

**If you answered YES to question 8, include documentation or evidence that documentation has been previously submitted with this certification form.**

9. Are the assumptions in the Qualitative Exposure Assessment still valid?  
(The Qualitative Exposure Assessment must be certified every five years)

**If you answered NO to question 9, the Periodic Review Report must include an updated Qualitative Exposure Assessment based on the new assumptions.**

**SITE NO. C203097**

**Box 3**

**Description of Institutional Controls**

<u>Parcel</u>	<u>Owner</u>	<u>Institutional Control</u>
<b>2738-35</b>	The City of New York	Ground Water Use Restriction Soil Management Plan Monitoring Plan Site Management Plan IC/EC Plan
Imposition of an institutional control in the form of environmental easement for the controlled property which will:		
-require the remedial party or site owner to complete and submit to the Department a periodic certification of institutional and/or engineering controls in accordance with Part 375-1.8 (h)(3);		
- allow the use and development of the controlled property for restricted residential use as defined by Part 375-1.8(g), although land use is subject to local zoning laws;		
- restrict the use of groundwater as a source of potable or process water, without necessary water quality treatment as determined by the NYSDOH or NYCDOH; and		
- require compliance with the Department approved Site Management Plan.		
<b>2738-36</b>	The City of New York	IC/EC Plan Ground Water Use Restriction Soil Management Plan Monitoring Plan Site Management Plan
Imposition of an institutional control in the form of environmental easement for the controlled property which will:		
-require the remedial party or site owner to complete and submit to the Department a periodic certification of institutional and/or engineering controls in accordance with Part 375-1.8 (h)(3);		
- allow the use and development of the controlled property for restricted residential use as defined by Part 375-1.8(g), although land use is subject to local zoning laws;		
- restrict the use of groundwater as a source of potable or process water, without necessary water quality treatment as determined by the NYSDOH or NYCDOH; and		
- require compliance with the Department approved Site Management Plan		
<b>2738-37</b>	The City of New York	Ground Water Use Restriction Soil Management Plan Monitoring Plan Site Management Plan IC/EC Plan
Imposition of an institutional control in the form of environmental easement for the controlled property which will:		
-require the remedial party or site owner to complete and submit to the Department a periodic certification of institutional and/or engineering controls in accordance with Part 375-1.8 (h)(3);		
- allow the use and development of the controlled property for restricted residential use as defined by Part 375-1.8(g), although land use is subject to local zoning laws;		
- restrict the use of groundwater as a source of potable or process water, without necessary water quality treatment as determined by the NYSDOH or NYCDOH; and		
- require compliance with the Department approved Site Management Plan		

**Box 4**

**Description of Engineering Controls**

None Required

Not Applicable/No EC's

**Periodic Review Report (PRR) Certification Statements**

1. I certify by checking "YES" below that:

a) the Periodic Review report and all attachments were prepared under the direction of, and reviewed by, the party making the Engineering Control certification;

b) to the best of my knowledge and belief, the work and conclusions described in this certification are in accordance with the requirements of the site remedial program, and generally accepted engineering practices; and the information presented is accurate and complete.

YES NO

2. For each Engineering control listed in Box 4, I certify by checking "YES" below that all of the following statements are true:

(a) The Engineering Control(s) employed at this site is unchanged since the date that the Control was put in-place, or was last approved by the Department;

(b) nothing has occurred that would impair the ability of such Control, to protect public health and the environment;

(c) access to the site will continue to be provided to the Department, to evaluate the remedy, including access to evaluate the continued maintenance of this Control;

(d) nothing has occurred that would constitute a violation or failure to comply with the Site Management Plan for this Control; and

(e) if a financial assurance mechanism is required by the oversight document for the site, the mechanism remains valid and sufficient for its intended purpose established in the document.

YES NO

Not applicable

**IF THE ANSWER TO QUESTION 2 IS NO, sign and date below and DO NOT COMPLETE THE REST OF THIS FORM. Otherwise continue.**

**A Corrective Measures Work Plan must be submitted along with this form to address these issues.**

\_\_\_\_\_  
Signature of Owner, Remedial Party or Designated Representative

\_\_\_\_\_  
Date

IC CERTIFICATIONS  
SITE NO. C203097

Box 6

**SITE OWNER OR DESIGNATED REPRESENTATIVE SIGNATURE**

I certify that all information and statements in Boxes 1,2, and 3 are true. I understand that a false statement made herein is punishable as a Class "A" misdemeanor, pursuant to Section 210.45 of the Penal Law.

I Aaron Koffman at Peninsula Building 2A LLC  
print name print business address

am certifying as Owner (Owner or Remedial Party)

for the Site named in the Site Details Section of this form.



Signature of Owner, Remedial Party, or Designated Representative  
Rendering Certification

5/30/23  
Date



Site Inspection Checklist and Photo Log

**ROUX ENVIRONMENTAL ENGINEERING AND GEOLOGY, D.P.C.**  
**SITE-WIDE MONITORING, INSPECTION AND MAINTENANCE FORM**

Client: The Peninsula JV, LLC  
Location: 1221 Spofford Avenue, Bronx, New York  
Inspector: Michelle Okvist  
Date: 5/1/2023

**Site Observations: Performed by ( Michelle Okvist ) on ( 5/1/2023 )**

Yes No

- Have any site improvements been made since the last inspection?  
  Has there been any maintenance activity impacting the institutional controls?  
  Are the monitoring wells intact?

-Include sketches or photos of observations.

**Inspection of Property Usage: Performed by ( Michelle Okvist ) on ( 5/1/2023 )**

Yes No

- Is the property being used for any purposes other than restricted residential, commercial, or industrial use?

-Include sketches or photos of observations.

**Inspection of Groundwater Usage: Performed by ( Michelle Okvist ) on ( 5/1/2023 )**

Yes No

- Is groundwater underlying the property being used for any purposes including, but not limited to, drinking water or industrial purposes?

-Include sketches or photos of observations.

**Inspection of Remaining Contaminated Material: Performed by ( Michelle Okvist ) on ( 5/1/2023 )**

Yes No

- Have there been any activities that caused a disturbance of remaining contaminated material since the last inspection?  
  If yes, were the activities conducted in accordance with the Site Management Plan (SMP)?  
If yes, refer to Page 2 for additional clarification..

-Include sketches or photos of observations.

**Inspection of Gardens and Farming: Performed by ( Michelle Okvist ) on ( 5/1/2023 )**

Yes No

- Is there any evidence of vegetable gardens and/or farming at the property?

-Include sketches or photos of observations.

Include additional information and details on Page 2 of this inspection form if the response to any of the above questions warrants additional explanation.





**Photograph 1:** Facing North, 300-gallon setting tank for operating onsite dewatering system.



**Photograph 2:** Facing northeast, general Site conditions in the western portion of the Site.



**Photograph 3:** Facing east, view of Site improvements in the courtyard area between Buildings 1A (left) and 1B (right).

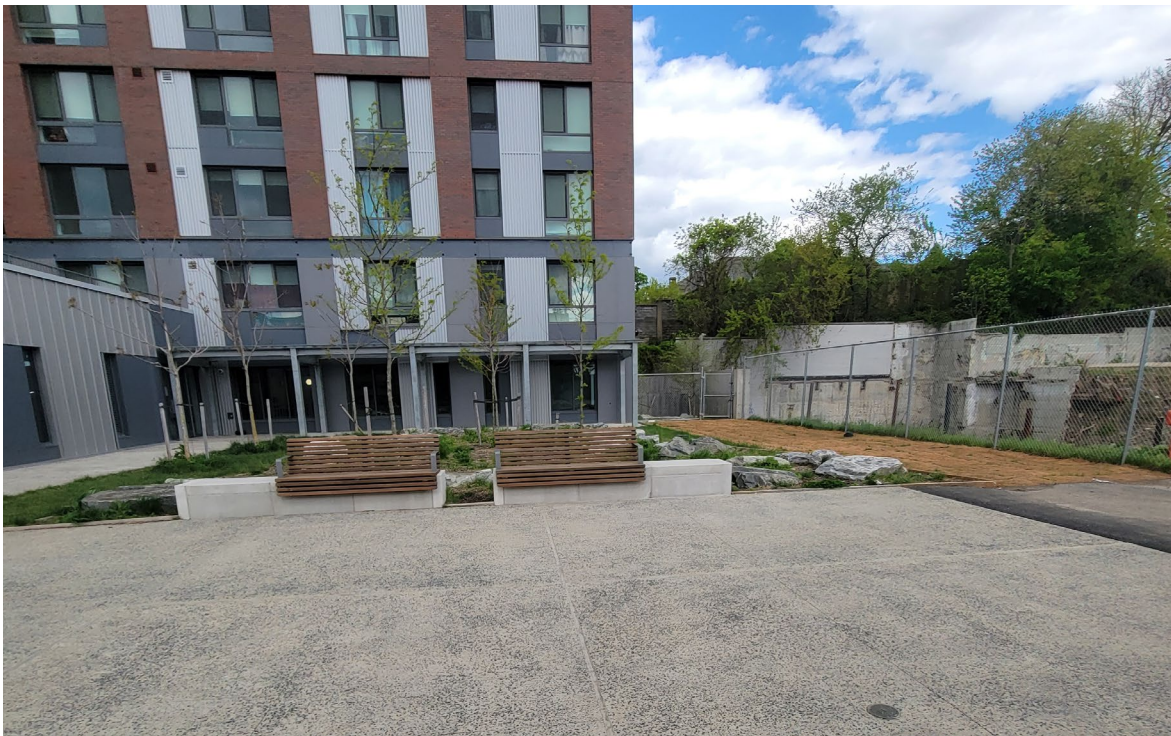

**Photograph 4:** Facing northeast, view of Site improvements and landscaping at Building 1B.



**Photograph 5:** Facing west, view of Site improvements consisting of ongoing construction of Buildings 1A (left) and 1B (right).



**Photograph 6:** Facing south, view of Site improvements at Building 1A and sidewalk along Tiffany Street.