

**VOLUNTEERS OF AMERICA – BACK LOT  
ALTERNATIVE ANALYSIS REPORT / REMEDIAL ACTION WORK PLAN**



**214 Lake Avenue – Back Lot  
Rochester, NY Site C828126**

**BCA Index #B 8 - 0688 - 05-04**

**Submitted to: New York State Department of Environmental Conservation**

**Prepared for: Volunteers of America of Western New York**

**Prepared by: Bergmann Associates**

**March 3, 2016**  
(Revised)



**TABLE OF CONTENTS**

<b>1.0</b>	<b>INTRODUCTION</b> .....	<b>1</b>
1.1	General.....	1
1.2	Report Organization.....	1
<b>2.0</b>	<b>SITE BACKGROUND AND SETTING</b> .....	<b>2</b>
2.1	Site Description.....	2
2.2	Site History.....	2
2.3	Previous Environmental Site Investigations.....	2
2.4	Recognized Environmental Conditions and Areas of Concern.....	3
<b>3.0</b>	<b>REMEDIAL INVESTIGATION SUMMARY</b> .....	<b>4</b>
3.1	Evaluation of Contaminant Levels.....	5
3.2	Nature and Extent of Contamination.....	5
3.3	Potentially Exposed Populations and Exposure Routes.....	10
<b>4.0</b>	<b>IDENTIFICATION AND DEVELOPMENT OF ALTERNATIVES</b> .....	<b>12</b>
4.1	Introduction.....	12
4.2	Local Land Use Factors.....	12
4.3	Identification of Remedial Action Objectives.....	12
4.4	Development of Remedial Action Objections (RAOs).....	13
4.4.1	On-Site Soil.....	13
4.4.2	On-Site Groundwater.....	13
4.5	General Response Actions (GRAs).....	14
4.6	Media Volume Summary.....	14
4.6.1	Soils.....	15
4.6.2	Groundwater.....	15
<b>5.0</b>	<b>EVALUATION OF REMEDIAL ALTERNATIVES</b> .....	<b>16</b>
5.1	Development of Alternatives.....	16
5.2	Analysis of Alternatives.....	18
5.3	Individual Analysis of Alternatives.....	18
5.3.1	Alternative 1 – No Action.....	18
5.3.2	Alternative 2 – Removal of All Historic Fill to Meet Track 1 Standards and Placement of Controlled Backfill with Restoration of Ground Surface.....	20
5.3.3	Alternative 3 – Site-Wide Cover System over Historic Fill with Excavation and Off-Site Disposal of Black Stained Sandy Soils Source Area.....	23
5.3.4	Alternative 4 – Site-Wide Engineered Cap over Impacted Soils with Soil Vapor Extraction Systems for <i>In Situ</i> Treatment of Black Stained Sandy Soils Source Area.....	27
5.3.5	Alternative 5 – Site-Wide Engineered Cap over Impacted Soils with Chemical Oxidation Remediation of Black Stained Sandy Soils Source Area.....	30
5.4	Comparative Analysis.....	34
5.4.1	Protection of Human Health & the Environment.....	34
5.4.2	Compliance with SCGs/ARARs.....	35
5.4.3	Long-Term Effectiveness and Permanence.....	37
5.4.4	Reduction in Toxicity, Mobility, and Volume.....	39
5.4.5	Short-Term Effectiveness.....	41
5.4.6	Implementability.....	42

5.4.7	Estimated Cost.....	44
5.4.8	Land Use.....	45
5.4.9	Green and Sustainable Remediation Principles.....	46
<b>6.0</b>	<b>RECOMMENDATIONS.....</b>	<b>48</b>
6.1	Alternative Recommendation.....	48
<b>7.0</b>	<b>REMEDIAL ACTION WORK PLAN – Overview.....</b>	<b>50</b>
7.1	Site Location and Current Usage.....	50
7.2	Pre-Remediation Conditions – Existing.....	51
7.3	Proposed (Post-Remedial) Conditions – Future.....	52
7.4	Summary of Proposed Redevelopment Plan.....	52
7.5	Description of Surrounding Property.....	52
7.6	Summary of the Remedy.....	53
7.7	Community Acceptance.....	54
7.8	Standards, Criteria and Guidance.....	54
7.9	Summary of the Remedial Goals.....	55
7.10	Remedial Action Objectives.....	55
7.11	Remedial Alternatives Analysis.....	56
<b>8.0</b>	<b>REMEDIAL ACTION.....</b>	<b>56</b>
8.1	Summary of Preferred Remedial Action.....	56
8.2	Soil Cleanup Objectives and Soil/Fill Management.....	58
8.3	Soil Fill Removal and Off-Site Disposal.....	58
8.4	Source Soil Removal Excavation.....	60
8.5	Backfill.....	61
8.6	Site-Wide Engineered Cover System Construction.....	62
8.7	Confirmation End-Point Sampling.....	62
8.8	Quality Assurance/Quality Control.....	63
8.9	Engineering Controls.....	64
8.10	Institutional Controls.....	65
8.11	Site Management Plan.....	66
8.12	Construction Water Management.....	67
8.13	Erosion, Dust, and Odor Controls.....	67
8.14	Storm water Management.....	67
8.15	Erosion and Sediment Control.....	68
8.16	Monitoring Well Decommissioning.....	68
8.17	Decontamination.....	69
<b>9.0</b>	<b>REMEDIAL ACTION MANAGEMENT – Project Organization &amp; Oversight.....</b>	<b>69</b>
9.1	Site Security.....	69
9.2	Work Hours.....	69
9.3	Construction Health and Safety Plan.....	69
9.4	Community Air Monitoring Plan.....	70
<b>10.0</b>	<b>SITE PREPARATION.....</b>	<b>71</b>
10.1	Utility Marker Layouts, Easement Layouts.....	71
10.2	Pre-Construction Meeting.....	72
10.3	Mobilization.....	72

10.4	Equipment and Material Staging.....	72
10.5	Stabilized Construction Entrance.....	72
10.6	Truck Inspection Station.....	72
10.7	Site Control.....	72
10.8	Traffic Control.....	73
10.9	Demobilization.....	73
<b>11.0</b>	<b>REPORTING AND RECORD KEEPING.....</b>	<b>73</b>
11.1	Daily Reports.....	73
11.2	Record Keeping and Photo-Documentation.....	74
11.3	Waste Stream Tracking and Verification.....	74
11.4	Complaint Management.....	74
11.5	Deviations from the RAWP.....	74
11.6	Data Usability Summary Report.....	74
11.7	Final Engineering Report.....	75
11.8	Agency Approvals.....	75
11.9	Schedule.....	75
<b>12.0</b>	<b>REFERENCES.....</b>	<b>76</b>

**TABLES:**

- TABLE 1: Estimated Total Present Worth: Alternatives 1 through 5  
 TABLE 2: Ranking Analysis of Alternatives

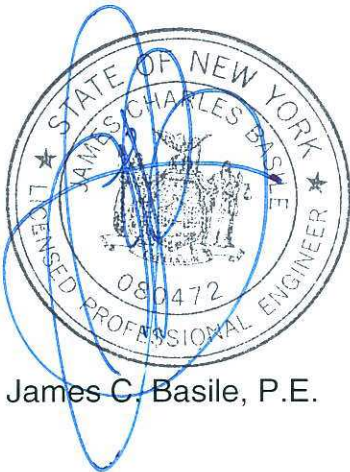
**FIGURES**

- FIGURE 1: Site Vicinity Map  
 FIGURE 2: Site Plan  
 FIGURE 3: Approximate Location of Former Ravine  
 FIGURE 4: Locations of Environmental Conditions  
 FIGURE 5: Groundwater Contour Map  
 FIGURE 6: SVOC and Metal Soil Sample Locations that exceed Soil Cleanup Objectives for Commercial Use  
 FIGURE 7: Soil Sample Locations that Exceed Protection of Groundwater Values  
 FIGURE 8: Groundwater Contaminants Distribution Plan - Metals  
 FIGURE 9: Groundwater Contaminants Distribution Plan - SVOCs  
 FIGURE 10: Distribution of Arsenic in Soil and Groundwater Samples  
 FIGURE 11: Distribution of Mercury in Soil and Groundwater Samples  
 FIGURE 12: Site Plan with Hot Spot Excavation Area - Draft  
 FIGURE 13: Site-Wide Engineered Cover with Grading / Utilities - Draft  
 FIGURE 14: Remediation Construction Specifications & Details – Draft



**Alternative Analysis Report / Remedial Action Work Plan Certification**  
**214 Lake Avenue, Rochester, NY – Back Lot Site C828126**  
**BCA Index # B 8-0688-05-04**

I James C. Basile, P.E. certify that I am currently a NYS registered professional engineer as defined in 6 NYCRR Part 375 and that this Alternate Analysis Report and Remedial Action Work Plan as prepared in accordance with the applicable statutes and regulations and in substantial conformance with the DER Technical Guidance for Site Investigation and Remediation (DER-10).



James C. Basile, P.E.

Date *3/31/2016*

I Stephen J. DeMeo certify that I an currently a Qualified Environmental Professional as defined in 6 NYCRR Part 375 and that this Alternate Analysis Report and Remedial Action Work Plan as prepared in accordance with the applicable statutes and regulations and in substantial conformance with the DER Technical Guidance for Site Investigation and Remediation (DER-10).

Stephen J. DeMeo  
Senior Geologist

Date *3/31/2016*



## 1.0 INTRODUCTION

### 1.1 GENERAL

The 214 Lake Avenue, Rochester, New York Site (Site) consists of an approximately three-acre parcel of property located in the City of Rochester, Monroe County, New York. The location of the Site is illustrated by Figure 1 – Site Vicinity Map. The Site has an extensive history of commercial and industrial activity that has negatively impacted soil and groundwater quality.

This Alternatives Analysis Report (AAR) / Remedial Action Work Plan (RAWP) for 214 Lake Avenue, Rochester, New York Back Lot (Site) was performed in accordance with the New York State Department of Environmental Conservation (NYSDEC) Brownfield Cleanup Program (BCP) Agreement between Volunteers of America of Western New York (VOA) and the NYSDEC (NYSDEC BCP Index No. B 8-0688-05-04, Site No. C828126). This AAR / RAWP has been prepared in accordance requirements of an Alternatives Analysis Report (AAR) / Remedial Action Work Plan (RAWP) pursuant to the NYSDEC *Part 375.3 of Title 6 of the Codes, Rules, and Regulations of the State of New York (6NYCRR) - Brownfield Cleanup Program regulation.*

A remedial investigation (RI) was completed in August 2012 to characterize the nature and extent of contamination present at the Site. An evaluation of the analytical results for the groundwater and surface/subsurface soil samples, which were collected as part of the RI, was presented in the Remedial Investigation Report (RI Report) dated August 3, 2012. These results were used in the preparation of this AAR / RAWP to evaluate remedial alternatives and to select the preferred remedial alternative. The preferred remedial alternative will best address the site-specific remediation requirements for restricted residential reuse.

The scope of work associated with this AAR / RAWP generally includes information regarding the Site and contamination issues, information regarding the selection of each cleanup alternative, and a comparative analysis of the remedial alternatives considered with details of the remedial action proposed. The analysis of the remedial alternatives presented in this report and the recommended alternative is based on VOA's planned Site goal for future restricted residential reuse.

### 1.2 REPORT AND PLAN ORGANIZATION

This document is organized as follows:

- Section 1.0 AAR report introduction;
- Section 2.0 Site RAWP background information and a description of areas of concern (AOCs);
- Section 3.0 Discussion of the contaminants in the site soil and groundwater along with potential exposure routes and migration pathways;
- Section 4.0 Presents the identification and development of potential remedial alternatives;
- Section 5.0 Presents a detailed analysis of the alternatives;
- Section 6.0 Presents the selected alternative and recommendations;
- Sections 7.0 - 11.0 – Remedial Action Plan; and
- Section 12.0 References.

## **2.0 SITE BACKGROUND AND SETTING**

### **2.1 SITE DESCRIPTION**

The 214 Lake Avenue Back Lot Site is owned by Volunteers of America of Western New York (VOA) and consists of an approximately 3 acre property located in the City of Rochester, Monroe County, New York (Figure 1). The Site is located on Tax Map No.105.600-0002-001.0020000. The Site is located east of the centerline of Haidt Place and VOA's Office Building, Thrift Store and Day Care Center (VOA's Human Services Complex), which is a fully remediated and redeveloped former Brownfield site that was cleaned up under the NYSDEC Spills program. The Site is located north of Ambrose Street, west of the former Raeco Oil Superfund Site, and south of a contractor's equipment storage yard and building and a Monroe County right-of-way to the Pure Waters Tunnel Structure 41. The Site is comprised of portions of two tax parcels of land, which are referred to as the eastern portion of Parcel A and all of Parcel B. The majority of the Site is largely undeveloped and the western portion of the Site is improved with parking lot area and roadway. On the east side of the site, soil berms and former bio-cells, now with vegetation cover, is present to block the view of the Raeco Oil Superfund Site. The Site location and surrounding vicinity are shown on Figure 1. The approximate limits of the Site area are shown on Figure 2 – Site Plan.

### **2.2 SITE HISTORY**

Historical research indicates that the Site was previously the southernmost portion of Rochester Gas & Electric (RG&E)'s approximately 20-plus-acre parcel known as the Ambrose Street or Lake Avenue Coal Yard. The part of the Ambrose Street Coal Yard that is currently VOA's property was used for surface coal storage from approximately 1918 through the mid-1960's. Subsequent to the use of the property for coal storage, the northeast portion of the Site was used by automobile dealerships from at least 1971 through 1997 for parking/storage of vehicles. Kaplan Container, a drum cleaning company was also present on the adjoining (off-site) western portion of Parcel A, see Figure 2. Prior to 1918, portions of the property had residential structures, which appear to have been demolished on the Site into a large deep ravine which traverses approximately the middle of the Site. This large ravine was historically filled. See Figure 3 – Approximate Location of Former Ravine. Lower and upper historic fill layers are present in the ravine and meet the DER-10 definition of "historic fill". Railroad tracks were then constructed on top of the historic fill to allow for the transport of the coal after the ravine was filled. The Site is currently vacant.

### **2.3 PREVIOUS ENVIRONMENTAL SITE INVESTIGATIONS**

A June 1996 Phase II Environmental Site Assessment (ESA) performed by GZA GeoEnvironmental (GZA 1996 Report) for a prior prospective purchaser of both Parcel A and B (214 Lake Avenue) revealed semi-volatile and heavy metal contaminants at the Site. These contaminants may be associated with the previous historical uses and operations, including the automobile dealerships, coal pile storage, landfilling activities, barrel reconditioning/storage, and/or automobile storage. A January 1997 Supplemental Phase II ESA performed by GZA GeoEnvironmental (GZA 1997 Report) further revealed petroleum, semi-volatile and heavy metal contaminants on Parcels A and B. Predominantly, petroleum related compounds were found on the western portion of Parcel A associated with a former gasoline station and automobile dealership located at that site.

In November 1997, VOA purchased Parcel A and Parcel B, in reliance upon the new Voluntary Cleanup Program (VCP), which was designed to facilitate the remediation and redevelopment of Brownfield sites and provide a liability release. The parcels were well situated on a major bus route, convenient for their future Human Services client (See Figure 1). In August 1998, Parcel A was sold to the County of Monroe Industrial Development Agency (COMIDA) in order to secure bond financing for the project on Parcel A. VOA retained ownership of Parcel B. However, VOA withdrew from the VCP before executing a Voluntary Cleanup Agreement (VCA) and proceeded with the remediation under the Petroleum Spill Program due to a new onerous liability release re-opener provision that had been added to the VCA model form at that time. At the request of the NYSDEC, VOA performed additional investigative work and remediation to complete the investigation of Parcel A under the Petroleum Spill Program, which was the only Parcel on which redevelopment activities were planned at the time. The Parcel A portion of the site proceeded under the Spills Program, and subsequent work in this Program included investigation, pre-remedial design, and remediation that was summarized in the May 1998 Remedial Action Plan (1998 RAP). The remediation was completed and a no further action letter was issued by the department, which allowed the planned daycare center/thrift store reuse to occur.

A gasoline release from underground storage tanks associated with a former gas station and automobile dealership located on Parcel A from approximately 1928 to 1966 caused petroleum (gasoline) contamination of the soil and overburden groundwater on Parcel A. This petroleum contamination, as well as contamination associated with the car dealership operation from sudden and accidental discharges to sewers, has been remediated under the NYSDEC Spills Program. A NYSDEC spill inactivation letter was issued on April 23, 2002 for the petroleum spill on Parcel A, which indicates no further remedial action is required for Spill No. 9604935. Parcel A was safe for the day care and other uses planned for Parcel A based on indoor air testing results that were provided to the Monroe County Health Department.

In June 2005, VOA entered the NYSDEC BCP for the eastern portion of Parcel A and Parcel B, which together comprise the Site subject to the RI report. The BCA (Index No. B 8-0688-05-04, Site No. C828126) was executed on June 15, 2005. Since the western portion of Parcel A, which was previously remediated under the Spills Program, is up-gradient from the Site, the RI was designed to not only investigate contamination from prior historic uses on the Site, but also to evaluate if the former car dealership on Parcel A had impacts on Parcel B. The historic fill on Parcel B has resulted in Site contamination described in the RI Report.

## **2.4 RECOGNIZED ENVIRONMENTAL CONDITIONS AND AREAS OF CONCERN**

Based on a review of the Site history and previous environmental investigations, several areas of concern (AOCs) were identified; see Figure 4 – Locations of Environmental Conditions. AOCs on-site include:

- Historic fill (site wide),
- Former coal pile storage (site wide),
- Buried coal and coal tar (site wide),
- Former automobile parking area (site wide),
- Soils in former bio-cells,
- Black Stained Sandy Soils (limited area)
- Soil piles,
- Kaplan Container Former Barrel Cleaning and Barrel Reconditioning Operations (off-site), and
- Former Gasoline Spill & Petroleum Related Uses (off-site).



Subsurface data has indicated that the depth of the on-site historic fill material ranges from 0 to greater than 45 feet below ground surface (bgs) across the Site in two distinct layers. The upper historic fill consisted of primarily gravel, sand, silt, cinders, slag, ash, coal, coke, wood, glass, and metal from the ground surface to approximately 14 to 22 feet bgs. The lower historic fill consisted of cinders and ash with old bottles, shoe soles, clam shells, metal and some gravel from approximately 22 to 45 feet bgs. The lower historic fill deposit is less dense than the upper historic fill deposit. The depth of the lower fill deposit is believed to be greater than 45 feet and may be as deep as approximately 80 feet in the center of the former ravine based on information from historic topographic maps. See Figure 3.

### 3.0 REMEDIAL INVESTIGATION SUMMARY

In June 2005, VOA entered into a Brownfield Cleanup Agreement for the investigation and remediation of the western portion of Parcel A and Parcel B. In August 2006, a Remedial Investigation Work Plan (RIWP) was prepared by GeoQuest Environmental Inc. (GeoQuest). Final modifications to the August 2006 RIWP were provided by NYSDEC in a letter dated December 22, 2006. These modifications were accepted on behalf of VOA in a letter dated January 8, 2007 and became a part of the approved RIWP. GeoQuest implemented the approved RIWP between October 2007 and April 2010. NYSDEC requested additional supplemental investigation work to be performed. A Supplemental RIWP to perform a Supplemental Investigation (SI) was prepared on September 22, 2009 and approved by NYSDEC on April 16, 2010. Bergmann Associates (Bergmann) became the engineer of record and implemented some remaining approved RIWP tasks and completed the SI field work in September 2011. The investigative data is summarized below.

In general, the procedures in NYSDEC Investigation Guidance Document DER-10 were followed throughout the remedial and supplemental investigations. In general, the scope of work included the following activities:

- Preliminary test boring and well location inspection, including site plan review and utility mark out.
- Soil samples from 11 soil test borings located in the vicinity of potentially impacted areas or near areas where impacts were previously detected. Test borings were advanced to approximately 10 feet below the groundwater table and monitoring wells were installed with 10 foot well screen intervals that extended approximately 2 feet above the groundwater table. Test borings and overburden monitoring wells were completed to depths ranging from 24 to 44.5 feet bgs. One soil sample was generally collected at depths above the water table from each test boring location.
- Surface soil sampling from 6 locations using hand tools to collect a sample from the ground surface to two inches below vegetative cover in accordance with NYSDEC approved modifications to the RI Work Plan. The surface soil samples were collected from unconsolidated historical fill soils.
- Installation of 7 overburden monitoring wells and 2 bedrock monitoring wells. Overburden monitoring wells were installed to a depth ranging from 24 to 45 feet at the locations where previous contamination was found, and at up-gradient and down-gradient Site boundary locations to more fully delineate potential off-site contamination. Two rounds of groundwater sampling were conducted during the course of the investigation for the evaluation of potential seasonal groundwater fluctuations with the exception of Monitoring well MW-107 that was sampled once, since this well was installed during the October 2010 SI.



- Excavation of 26 test pits during the RI field work and 10 test pits during the SI field work was implemented to evaluate the nature and extent of historical fill and to determine the nature and extent of potential source areas requiring remediation. Sub-surface soil samples were also collected from selected test pit locations to characterize the nature of the material encountered.

### 3.1 EVALUATION OF CONTAMINANT LEVELS

The analytical results for surface and subsurface soil results collected during the remedial investigation were compared to the 6 NYCRR Part 375 Unrestricted Use Soil Cleanup Objectives (Unrestricted SCOs or Brownfield Cleanup Program (BCP) Track 1 SCOs), the Protection of Groundwater SCOs, and the Commercial SCOs or Commercial Track 2 standards. The Unrestricted SCOs represent the concentration of a contaminant in soil which, when achieved at the Site, will require no use restrictions on the Site for the protection of public health, groundwater and ecological resources due to the presence of contaminants in soil. Since the nature and extent of the historic fill encompasses the entire land mass at the site to depths of 60-80 feet below ground surface (bgs) a Track 1 cleanup would essentially require the entire historic fill area (land mass) to be excavated to achieve a Track 1 remedial goal. Therefore, this Site is not expected to meet a Track 1 cleanup scenario due to the area-wide and depth or thickness of the historic fill. The VOA's planned development, which will primarily consist of asphalt pavement and building materials, with a first floor commercial development, will serve as a cap to prevent exposure to impacted historic fill materials. The remedial goal will be a Track 4 restricted residential use remedy. Since, achievement of the Track 2 levels for any use would require excavation of 0-15 feet throughout the Site land mass and this type of mass excavation is also not economically feasible for this Site or the volunteer.

All fresh groundwater in New York State are classified as GA. Class GA groundwater pertains to all fresh water found in the saturated zone of unconsolidated deposits and consolidated rock or bedrock. The groundwater analytical results were compared to the Class GA groundwater standards in 6 NYCRR §703.5 and/or guidance values presented in the NYSDEC, Division of Water Technical and Operational Guidance Series 1.1.1 (TOGS 1.1.1); Ambient Water Quality Standards and Guidance Values and Groundwater Effluent Limitations.

### 3.2 NATURE AND EXTENT OF CONTAMINATION AOC 1: Historic Fill (Site wide)

Eleven soil borings, nine monitoring wells, six surface sample samples, and 36 test pits were completed in the historic fill. Samples were analyzed for Target Compound List (TCL) volatile organic compounds (VOCs) and semi-volatile organic compounds (SVOCs), Target Analyte List (TAL) metals, polychlorinated biphenyls (PCBs), pesticides, total cyanide, and United States Environmental Protection Agency (USEPA) Method 8015B Diesel range organics (DRO) and gasoline range organics (GRO). A sample of investigation-derived soil cuttings from test borings and purge water from wells was collected and analyzed for toxicity characteristic leaching procedure (TCLP). In addition, one soil sample from the Historic Fill and one sample from black stained sandy soils from test pit TP-132R were also submitted to the laboratory for TCLP analysis. The following text sections summarize the sampling rationale and findings associated with the surface soil and subsurface soil in the historic fill media and the overburden groundwater media.

#### Surface Soil

Twenty one (21) surface soil analyses were performed on samples from six surface soil sample locations SS-1 through SS-6 to evaluate the surface soil media at the Site. Visual and olfactory

evidence of petroleum contamination was not noted and there was non-detection of total organic vapors based on field screening with a photoionization detector (PID). Some fragments of coal and cinders were observed in the surface soil samples. SVOCs were detected at SS-1, SS-2, SS-3, and SS-5 at concentrations that exceed the Commercial SCOs. The concentration of metals (Lead and Mercury) in surface soil sample SS-1 exceeds the Commercial SCOs. The surface soils are historic fill materials (upper fill) based on the visual observations and historic information at this Site. VOCs, PCBs, and pesticides were not detected at concentrations above the Residential and Commercial SCOs. These findings indicate that the historic fill material, which comprises the surface soil, contains SVOCs with concentrations that exceed the Commercial SCOs at half of the locations sampled and at one location exceed Commercial SCOs for metals. Four sample locations exceed the Protection of Groundwater SCOs.

### Subsurface Soil

One hundred and thirty five (135) subsurface soil analyses were performed on samples from 28 subsurface soil sample locations (7 test boring/monitoring wells and 21 test pit locations) to evaluate the subsurface historic fill material present at the Site. Metals and SVOCs were detected at concentrations that exceed the Unrestricted Track 1 Residential and Restricted Track 2 Commercial SCOs. VOC, PCBs, pesticides, and total cyanide were not detected at concentrations that exceed the Unrestricted Track 1 Residential SCOs. In general, VOCs were not detected that are typically associated with petroleum contamination from petroleum bulk storage or automotive dealerships. These laboratory analytical results indicate that the subsurface soil is historic fill material, which contains metals and SVOCs that exceed Restricted Commercial and residential SCOs, and Protection of Groundwater SCOs.

### Groundwater

One hundred and three (103) groundwater analyses were performed on samples from 7 overburden monitoring wells and 2 bedrock monitoring wells, during two RI groundwater sampling events and monitoring well MW-107 was sampled as part of the SI to evaluate the overburden and bedrock groundwater quality. The types of metals which were detected in the overburden groundwater that exceed the Class GA §703.5 groundwater standards and T.O.G.S. 1.1.1. Guidance values are the same metals that were detected in the historic fill samples. This indicates that the historic fill has had an effect on the overburden groundwater quality with respect to metals. Bedrock groundwater was less impacted with lower concentrations of metals that exceed the Class GA 703.5 groundwater standards and T.O.G.S. 1.1.1. Guidance values when compared to overburden groundwater quality. Therefore, it appears that bedrock groundwater is less impacted by the historic fill than overburden groundwater, and contains lower concentrations for metals.

To further evaluate the concentrations of metals in groundwater detected during the two RI sampling events, unfiltered and filtered groundwater samples were collected for laboratory analyses in December 2012 using “ultra-low flow” sampling techniques from overburden monitoring wells MW-101, MW103, MW-105, and MW107. These four overburden monitoring wells were selected because they generally exhibited the highest concentrations of arsenic and mercury during the previous sampling events. As detailed in the RIR Addendum, the metals concentrations were dramatically lower suggesting the most recent data better represents the actual levels of metals that are moving in the groundwater.

It should also be noted that SVOCs were detected at the low ppb range in the overburden groundwater samples and less detection of SVOCs with lower concentrations in the bedrock groundwater samples during the initial groundwater sampling event. SVOCs were not detected above the method detection limits during the second groundwater sampling event in overburden and bedrock groundwater samples. Moreover the most recent December 2012 ultra-low flow samples showed even lower levels. The lower concentrations of metals in the bedrock groundwater samples is likely due to the dense glacial till soils that provide lower permeable soils and some separation of historic fill soils and overburden groundwater from the underlying bedrock groundwater.

VOCs were detected in the low ppb range in groundwater samples from monitoring wells MWR-102 and MW-106 locations that exceed the Class GA §703.5 groundwater standards and T.O.G.S. 1.1.1. Guidance values. Chlorobenzene was detected in the groundwater sample from MW-106 with a concentration of 22 ppb that exceeds the groundwater standard of 5 ppb. Methyl Tert-Butyl Ether (MTBE) was detected in the groundwater sample from monitoring well MWR-102 with a concentration of 31.0 ppb that exceeds the groundwater guidance value of 10 ppb. VOCs were not detected above the groundwater standards in the other groundwater samples and VOCs are not a contaminant of concern in the groundwater media. PCBs, pesticides and cyanide were not detected in the groundwater samples above the method detection limits.

#### Black Stained Sandy Soils

An area of black stained sandy soils was encountered in TP-131 and TP-132. While these soils are also historic fill, this material is not comprised of cinder, ash and coal fragments that are common to the majority of the historic fill at the Site. This distinct area of black stained sand and silt soils, which exhibited creosote-like odors as observed by Bergmann and NYSDEC representatives who were present at the time, was revealed in test pits TP-131 and TP-132 near the north central portion of the Site. Total organic vapors measured from soils excavated from these test pit locations ranged from 19.8 parts per million (ppm) to 84 ppm in TP-131 and 19.8 ppm to 440 ppm in TP-132. The depth of the black stained sand and silt fill soils (black stained sandy soils) was encountered from approximately 6 to 8 ft. below bgs and was greater than 20 feet deep and the vertical extent was not determined at these test pit locations. Test pits TP-133 through TP-136 were excavated to delineate the horizontal extent of the impacted black sandy soils at the direction of the NYSDEC field representative. Based on the test pit investigation, the black sandy soils are present in an area approximately 35 ft. by 35 ft., and which is centered on TP-132. Analytical soil sample results of these soils indicate detections of polycyclic aromatic hydrocarbons (PAHs), which are a natural component of coal and are found in combustion products. PAHs were also detected in soil samples from TP-128 (8-10 ft.) and TP-130 (8-10 ft.), which are also located in the north central portion of the site. Laboratory analytical results of soil sample TP-132 for EPA 8015B DRO reported 2,200 ppm. Arsenic was also detected in the black stained sand and silt fill soil samples from TP-131 (53.5 ppm), which exceeded the Commercial SCO level of 16 ppm.

In summary, as a result of the presence of historic fill soil, groundwater quality has been impacted and the levels of certain metals and Polycyclic Aromatic Hydrocarbons (PAHs a subset of SVOCs) detected in soil and groundwater samples exceed the restricted commercial SCOs, the Protection of Groundwater SCOs, cleanup objectives and §703.5 groundwater standards / T.O.G.S. 1.1.1. Guidance values. Historic fill from what appears to be a variety of sources, including but not limited to areas of buried coal and coke, an area of limited black stained sandy soil within the historic fill and approximately 55 years of coal pile surface storage have collectively contributed to impacts to Site soil and groundwater quality with respect to SVOCs and metals contamination.

## **AOC 2: Former Coal Pile Storage (Site wide)**

Eleven soil borings were installed and nine soil borings were completed as groundwater monitoring wells. In addition, 36 test pits were installed and 6 surface soil samples were collected to investigate soil conditions throughout the area of the Site that was formerly used as a coal pile storage area. Soil samples were analyzed for TCL VOCs and SVOCs, TAL metals, total cyanide, pesticides and PCBs.

Coal and coke were observed buried in layers within the historic fill (Upper Fill) at several locations across the Site with the exception of test pits TP-109, TP-110, TP-116, TP-117, TP-118 and TP-120. The coal and coke ranged in thickness from 0.5 ft. to greater than 20 ft. at the following soil borings and test pit locations with corresponding depth intervals as presented as follows:

<u>Soil Boring / Test Pit ID with thickness in feet</u>	<u>Depth Interval feet below Ground Surface</u>
MW-104 (3.5 ft.)	0.5-4 ft.
MW-107 (7 ft.)	1-8 ft.
TP-104 (3 ft.)	1-4 ft.
TP-107 (3.5 ft.)	0.5-4 ft.
TP-114 (3.5 ft.)	0.5-4 ft.
TP-115 (7 ft.)	1-8 ft.
TP-127 (6 ft.)	2-8 ft.
TP-128 (4 ft.)	2-8 ft.
TP-129 (>20 ft.)	2->22 ft.
TP-130 (3 ft.)	1-4 ft.
TP-132 (3 ft.)	1-4 ft.
TP-133 (3 ft.)	1-4 ft.
TP-135 (3 ft.)	1-4 ft.

Layers of coke that are approximately 2 ft. thick were also observed in test pits TP-115 from approximately 8 ft. to 10 ft. bgs and in TP-127 from approximately 10 ft. to 12 ft. bgs. A layer of coal and gravel was observed to be approximately 2.0 ft. thick was also observed at the monitoring well MW-103 location. The layer of coal and coke was deepest in TP-129.

Field observations of coal on the ground surface and layers of buried coal and coke remain on the Site as part of the historic fill. Elevated concentrations of PAHs and metals concentrations in soil/groundwater samples indicate that the use of the Site for former coal pile storage has likely contributed impacts to the Historic fill and overburden groundwater quality at the site. Coal fragments were also observed in the ash and cinders of the historic fill.

## **AOC 3: Coal Tar**

Buried coal tar was not encountered during the RI/SI subsurface investigations.

## **AOC 4: Impacts from Parked Automobiles (Site Wide)**

Petroleum related compounds that are typically used at automobile dealerships or found in gasoline were generally not detected in the six surface soil samples SS-1 through SS-6. Visual and olfactory

evidence of petroleum contamination was not noted during the collection of these samples, and there was non-detection of total organic vapors based on field screening with a PID.

#### **AOC 5: Soils Contained in Former Bio-cells**

Nine soil samples were collected from soil contained in three bio-cell locations located at the northeast end of the Site. These soils were placed in the bio-cells from the former gasoline spill area located on the western portion of Parcel A. In addition, some of the soils were petroleum impacted soils removed from catch basins from the former automobile dealership building and also from the former automobile body shop building. The soil samples were analyzed for SVOCs, TAL metals, PCBs and pesticides. It appears that the soil contained in the former bio-cells is generally not impacted with SVOCs, metals, PCBs and pesticides. However, two SVOCs [benzo (a) pyrene and dibenz (a, h) anthracene] were detected in VOA Bio-cell 101 sample that slightly exceeds the Commercial SCOs.

Protection of Groundwater SCOs were also exceeded for Benzo (a) Anthracene, Benzo (b) Fluoranthene, Benzo (k) Fluoranthene, and Chrysene in VOA bio-cell 101 sample. The concentration of Mercury also exceeded the Protection of Groundwater SCO in this sample. Protection of Groundwater SCOs were not exceeded in the other Bio-cell samples.

#### **AOC 6: Soil Piles from the Construction of the VOA Facility**

Soil piles were placed on the Site during the construction of the VOA Human Services Complex. The soil sample results indicate elevated SVOCs with concentrations that exceed the Commercial SCOs in soil samples TP-121, TP-122, TP-123, TP-124, and TP-126. Concentrations of metals (Lead and Mercury) exceed the Commercial SCOs in soil samples from TP-121 and TP-123, respectively.

Soil sample results also indicated elevated SVOCs with concentrations that exceed the Protection of Groundwater SCOs in soil samples TP-121, TP-122, TP-123, TP-124, and TP-126. Concentrations of metals (Lead and Mercury) exceed the Protection of Groundwater SCOs in soil samples TP-121, TP-123, and TP-124.

#### **AOC 7: Barrel Cleaning and Barrel Reconditioning Operations (off-site)**

Correlation of potential impact to the groundwater quality from the former off-site barrel cleaning and barrel reconditioning operations was not evident from the groundwater samples evaluated.

#### **AOC 8: Former Gasoline Spill (off-site)**

VOC and SVOC concentrations in overburden and bedrock groundwater samples indicate that the groundwater is not impacted with gasoline or diesel derived chemical compounds typically associated with petroleum bulk storage or automobile dealerships. It appears that the former automobile dealership uses and former gasoline spill on the western portion of Parcel A has not impacted overburden and bedrock groundwater quality at levels that require remediation of gasoline chemical compounds on this Site. Therefore, correlation of potential impact to the groundwater quality from the former off-site automobile dealership and former gasoline spill was not evident from the groundwater samples evaluated.



### 3.3 POTENTIALLY EXPOSED POPULATIONS AND EXPOSURE ROUTES

Potential human receptors under current conditions are limited to occasional persons that may trespass on the vacant field area of the Site. During construction and remediation activities, receptors will include construction and remediation workers, and workers on adjoining properties. Under the planned future land use, the selected remedial alternative will prevent human exposure to Site contaminants.

#### Exposure Pathways — On-Site Current Conditions

The composition of the historic fill at the Site contains various SVOCs (PAHs) and metals in surface and subsurface soil. The Site primarily consists of exposed soil and vegetation with the exception of a paved area located on the western portion of the Site. In localized areas where human exposure to the historic fill is possible (i.e., ground surface is not paved or capped), the potential migration pathway is likely complete for dermal absorption and ingestion. Site activity is not limited as the site is not fenced or secured.

Human exposure to impacted groundwater at the Site by ingestion is not an exposure pathway. Since, the Site is supplied by the City of Rochester Bureau of Water with primary sources of drinking water from Hemlock and Canadice Lakes and a supplemental source from Lake Ontario.

Overburden groundwater beneath the Site contains some metals, and some SVOCs, above applicable NYSDEC Class GA 703.5 groundwater standards. Since, overburden groundwater is in direct contact with the historic fill materials. However, the most recent groundwater data reflects the limited flow of the contaminants in groundwater. Groundwater flow direction, evaluated from overburden groundwater elevations, is towards the former ravine from the west and east sides of the Site, and there appears to be a northern trend of groundwater flow direction along the center of the Site that coincides with the approximate location of the centerline of the former ravine, see Figure 3 and Figure 5 – Groundwater Contour Map.

#### Construction/Remediation Activities

Remediation activities and future earthwork construction at the Site will result in potential exposures to Site contaminants by remediation contractors and future contractors. An excavation work plan will be required in areas of residual contamination as part of a site management plan to prevent this exposure pathway in the future. The proposed activities include excavation and removal of the most impacted soil and site-wide cover system. Therefore, the potential exists for exposure of soil contaminants of concern (COCs) to construction workers via dermal absorption, ingestion, and inhalation. A CAMP will be implemented and actions will be taken to provide a measure of protection for the surrounding community from potential airborne contaminant releases as a direct result of remedial work activities.

Although groundwater is not likely to be encountered during construction or remediation activities due to its depth starting at 22 feet bgs, if groundwater is encountered during excavation activities, exposure to workers of groundwater COCs is also possible via dermal absorption, ingestion, and inhalation. The CAMP will be implemented and actions will be taken to provide a measure of protection for the surrounding community from potential airborne contaminant releases as a direct result of remedial work activities. Work will be performed in accordance with a Health and Safety Plan (HASP), a Soil Management Plan (SMP), and a Community Air Monitoring Plan (CAMP), including an

air monitoring program, donning personal protective equipment, and applying vapor and dust suppression measures to prevent off-site migration of contaminants during remediation and future construction would reduce this potential migration pathway.

### Proposed Future Conditions

The Site is targeted for potential future restricted residential or commercial reuse. Plans regarding the future development have not yet been generated. A site-wide engineered cover system will be used for remediation throughout the site that includes an 18-inch subbase and Asphalt surface (4-inches). Upon completion of the site-wide engineered cover system, the majority of the Site will be overlain with a six-inch asphalt surface, with approximately eighteen inches of sub-base material for a total approximately two foot thick cover system. This cover system will serve as a barrier to prevent direct human exposure to impacted soil and groundwater left in place. The soils in the black stained sandy silt soil (hot spot) area will be excavated and transported off-site for disposal prior to completion of the cover system.

Following completion of the selected remediation activities, the groundwater will be sampled to evaluate potential effects from the hot spot removal soil remediation, site-wide cover system and potential dewatering activities (if required ) on the groundwater quality. A vapor barrier and an active Sub-Slab Depressurization Systems (SSDSs) would be required to minimize potential risks of potential vapor intrusion into future buildings that may be constructed on the Site. Vapor barriers, SSDSs, or other appropriate remedial measures will be designed based on existing Site data and new data that is revealed from sample results and observation during remediation. All post-remediation elements will be presented in a Site management plan.

### Potential Exposure Pathways - Off-Site

Because of the overall northerly groundwater flow direction through the filled ravine, it is possible that groundwater contaminants are migrating off-site. However, the most recent December 2012 ultra-low flow samples demonstrated that off-site migration is not occurring with elevated levels that exceed NYSDEC Class GA 703.5 groundwater standards for contaminants of concern, with the exception of Lead and Mercury in sample MW-103 that slightly exceeds this standard, and the off-site migration of contaminants in the groundwater from the southern portion of the Site towards the north end of the site is not expected to result in a complete exposure pathway for current, construction/remediation, or future conditions for the following reasons:

- The Site and surrounding areas obtain their drinking water supply from municipal supply.
- Groundwater that is impacted would likely discharge to the Genesee River and not to a human receptor.

Therefore, the COCs are not expected to reach a surface water body that is used as a drinking water source to potentially complete an exposure pathway.

### Summary

Depending on the remedial alternative implemented, complete on-site exposure pathways may exist between the historic fill and groundwater with human receptors during current conditions, future remediation and construction activities. Potential pathways include direct contact (dermal absorption),

ingestion, and inhalation of soil and groundwater contaminants. Complete off-site exposure pathways are not thought to exist between the Site media and human receptors during current conditions and after future Site remediation and construction is complete. During future remediation activities and earthwork construction precautions will be required to protect remediation/construction workers and the general public on adjoining properties.

## **4.0 IDENTIFICATION AND DEVELOPMENT OF ALTERNATIVES**

### **4.1 INTRODUCTION**

The purpose of identifying remedial alternatives for the Site is to identify and evaluate the most appropriate remedial action for a contaminated AOC or specific media at the Site. The goal of all remedial alternatives evaluated is to eliminate or mitigate significant threats to public health and the environment presented by the contaminants identified at the Site through proper application of scientific and engineering principles.

Remedial action objectives (RAOs) form the basis for identifying remedial technologies and developing remedial alternatives. This section identifies RAOs for surface soils, subsurface soil and groundwater. General response actions (GRAs) are provided to address the RAOs and the extent of soil and groundwater contamination requiring remedial action. Site-specific RAOs were developed with consideration for the contaminant concentrations, chemical and toxicological properties of the COCs, existing or potential exposure pathways, and anticipated future land use.

### **4.2 LOCAL LAND USE FACTORS**

The current and possible future land uses of the Site are critical to the development of current and future human exposure scenarios. Exposure evaluations such as type of exposure, exposure frequency, and exposure duration were determined based upon current land use, current zoning and planning, local populations, and future land use plans.

The Site is located in an area of a mixed commercial, industrial and residential uses. The Site has a history of commercial/industrial activity and is vacant, with the exception of several automobile parking spaces and portions of the roadway used for VOAs Human Service Complex. VOA is working to position the Site for future restricted residential or commercial reuse and specific plans have not been developed.

### **4.3 IDENTIFICATION OF REMEDIAL ACTION OBJECTIVES**

The RAOs for the Site are medium-specific or AOC-specific objectives, which are established for the protection of human health and the environment. Based on the results of the remedial investigation, and the current and potential future use of the Site and surrounding areas, the following general RAOs were developed to reduce, to the extent feasible:

- Potential ingestion, dermal contact, inhalation, and direct contact exposures of persons or workers at or around the Site to SVOCs and metals in soil or groundwater; and,
- Potential ingestion and inhalation exposures of persons or workers at or around the Site to SVOCs and metals in dust (soil dust) that may migrate off-site by wind.

These RAOs will be accomplished by implementation of a remedy for a Track 4 restricted commercial use protective of public health and the environment through:

- Removal, to the extent practicable, or in-situ treatment of the potential impacted soil source area (Black stained sandy soil area);
- Creation of a cover system to prevent human contact with contaminated soils, historic fill, and groundwater; and,
- Use of long term institutional and engineering controls to reduce long term potential exposure pathway to human receptors and the environment.

The screening and evaluation of remedial action technologies and alternatives will focus on the ability to achieve these general RAOs.

#### **4.4 DEVELOPMENT OF REMEDIAL ACTION OBJECTIVES (RAOs)**

##### **4.4.1 On-site Soil**

As discussed in the RI report, select SVOCs (PAHs) and metals exceed the SCOs in surface soils, subsurface soils and groundwater at the Site. The extent of contamination at the Site appears to be due primarily to the historic fill material found throughout the Site and historic use of the Site as a coal storage yard. Additionally, one area of black stained sandy soil, which was not representative of the other historic fill on the Site, was encountered during the Supplemental RI at the north end of the Site.

Identified potential exposure pathways for on-site soil include ingestion, inhalation of contaminated dust, and dermal contact. Under current conditions, there is the potential for exposure to the contaminants contained within the Site surface soils by trespassers and Site workers through dermal contact, ingestion, and/or inhalation.

Due to the intended future ground level commercial use of the Site, the amount of soil and groundwater which will be covered by future building / pavement, and the lack of volatile contaminants in the Site soil/groundwater, remedial actions are warranted to eliminate the potential for direct human exposure for the anticipated future Site development scenario.

Therefore, further exposure of the contamination to potential environmental and human receptors will be reduced.

##### **4.4.2 On-site Groundwater**

Overburden groundwater is impacted with concentrations of some metals and SVOCs, and detection of two VOCs in one groundwater samples that marginally exceeded the class GA groundwater standards. The bedrock groundwater in the top of the bedrock zone appears to be less impacted with generally lower concentrations and less detection of Metals and SVOCs. Overburden groundwater quality has been impacted by the presence of historic fill, which is in contact with the groundwater table. Analytical data collected indicates that the groundwater underlying the northern section of the Site has the highest concentration of metals, some of which are present at levels slightly exceeding the class GA groundwater standards.

Groundwater is not likely to be encountered during construction or remediation activities due to its depth starting at approximately 22 feet bgs.

Groundwater is not used or planned to be used at the Site or in the vicinity of the Site for drinking water purposes and the Site vicinity is serviced by municipal water supply. Therefore, exposure routes for ingestion or adsorption from groundwater is considered to be an incomplete exposure pathway after development and its future use will be restricted through an institutional control use restriction, which shall run with the land. As a result, remedial objectives to reduce potential human and environmental exposure associated with the impacted groundwater will include engineering and institutional controls. The remedial objective for groundwater at the Site will be to reduce contact and eliminate any use of groundwater. The overall RAO for the groundwater media is protection of human health and the environment by means of a cover system and institutional controls.

#### **4.5 GENERAL RESPONSE ACTIONS (GRAs)**

After establishing the RAOs for the Site, several general response actions (GRAs) were evaluated based upon the ability of the response to address the remedial RAOs. These actions are intended to mitigate potential exposure to Site COCs, control the migration of the COCs on the Site, and/or remediate the COCs to the extent practicable. The purpose of establishing GRAs is to begin to evaluate basic methods of protecting human health and the environment, such as removal, treatment, and/or containment of the Site contaminants. The GRAs may then be combined to form alternatives, such as treating contaminated media (if necessary) and providing barriers, containment, or post-treatment monitoring of residual contaminants.

The following list summarizes the GRAs that were considered for remediation of the contamination that is present at the Site:

- No Further Action
- Institutional and Administrative Controls
- Natural Attenuation with Continued Monitoring
- Physical Containment / Cover
- In-Situ Treatment
- Removal with Off-site Disposal

Each of the GRAs will be analyzed for each remedial alternative in Section 5.0 below.

#### **4.6 MEDIA VOLUME SUMMARY**

RAOs have been developed for soil and groundwater at the Site. The media potentially requiring remediation is summarized in the following subsections. For comparison purposes, Figure 6 – SVOC and Metal Soil Sample Locations that Exceed Soil Cleanup Objectives for Commercial Use and Figure 7 – Soil Sample Locations that Exceed Protection of Groundwater Values present the locations of subsurface soil concentrations exceeding the Restricted Commercial and Residential SCOs and Protection of Groundwater SCOs. The distribution of overburden groundwater contaminants exceeding the GA groundwater standards is presented in Figure 8 – Groundwater Contaminants Distribution Plan – Metals and Figure 9 – Groundwater Contaminant Distribution Plan - SVOCs. Additionally, soil concentrations exceeding the Restricted Commercial and Residential SCOs and Protection of Groundwater SCOs for Arsenic and Mercury are presented on Figure 10 – Distribution of



Arsenic in Soil and Groundwater Samples and Figure 11 – Distribution of Mercury in Soil and Groundwater Samples.

#### 4.6.1 Soils

##### Historic Fill

The Site consists primarily of historic fill that ranges in depth to greater than 45 feet along the western side of the Site and greater than 20 feet along the eastern side of the Site. In the center of the Site the historic fill may be as deep as approximately 80 feet deep based on a review of historic topographic maps, which are included in the RI Report. Previous Phase II ESAs (GZA 1996 and 1997) identified soil and groundwater contamination on the Site with cinders, ash, and coal fragments described as fill deposit. Soil and groundwater sample analyses from these previous Phase II ESAs revealed detection of concentrations of SVOCs and metals, which exceeded applicable standards, criteria, and guidance values. Sanborn Fire Insurance Maps also indicate that the Site was landfilled, which were included in the RI Report. Potential COCs include SVOCs and metals. If the entire volume of historic fill were to be removed from the Site an estimated 144,000 yd<sup>3</sup> would have to be removed.

##### Black Stained Sandy Soils (Historic Fill)

The Black Stained Sandy Soil area is a limited area of impacted historic fill soils, which is physically and chemically different than other historic fill present. While this black sandy soils area is also historic fill, this material is not comprised of cinder, ash and coal fragments common to the majority of the historic fill at the Site. This distinct area of black stained sand and silt soils exhibited creosote-like odors when observed by Bergmann and NYSDEC representatives who were present at the time it was revealed in test pits. This limited area (approximately 35' x 35') at the northern end of the Site does contain soils with elevated organic vapors from approximately 8 feet bgs to depths greater than 20 feet. The elevated total organic vapor readings ranged from 300 ppm to approximately 440 ppm. While these soils were determined to be characteristically non-hazardous based on the TCLP laboratory results, the result for diesel range organic compounds was 2,200 ppm. The black stained sandy soils area has not been fully delineated with respect to vertical depths below 20 feet. The horizontal extent was completed based on test pit excavation observations. Therefore, the impacted soil quantity is estimated to be approximately 1,134 cubic yards (yd<sup>3</sup>) based on an area roughly measuring 35 feet long by 35 feet wide by 20 feet deep.

#### 4.6.2 Groundwater

VOCs, SVOCs (PAHs), and some inorganic compounds were detected at levels above Class GA groundwater standards in groundwater at the Site. VOCs and some metals in the overburden and bedrock groundwater were not detected above the GA groundwater standards or guidance values, except for two isolated and temporary detections of MTBE and Chlorobenzene, which slightly exceeded the GA groundwater standards or guidance values, and which were not repeated during a second round of groundwater sampling in the same monitoring wells where these prior results were obtained. The overburden groundwater and bedrock groundwater is generally not impacted with VOCs at the locations sampled. Therefore, VOCs are not a COC in the groundwater at the Site. Based on these results, it appears that historic petroleum related uses and the former gasoline spill on Parcel A Site have not impacted the groundwater at the Site.

The SVOC sample results indicate that 4 out of the 6 overburden groundwater samples exceed the Class GA groundwater standards for several SVOCs during the October 2008 groundwater sampling event (seasonal wet period). SVOCs were not detected above the Class GA groundwater standard during the July 2009 (dry seasonal period) event. The source of the estimated detections of SVOCs in the overburden groundwater is likely from the historic fill that contains coal, coke, ash, cinders, coal fragments, and slag fill materials. The SVOC sample results from 2 bedrock monitoring wells during the October 2008 and July 2009 groundwater sampling events indicate that one groundwater sample from monitoring well MWR-102 exceeds the Class GA groundwater standards. Other SVOCs were not detected above the Class GA groundwater standard during the July 2009 (dry seasonal period) event. The low ppb range of detection and the limited SVOCs detected indicates that SVOCs in the bedrock groundwater are not COCs.

The overburden groundwater sample locations with the highest levels of metals during the RI were collected from monitoring wells MW-103 and MW-107. Both of these wells are screened from 31 to 41 ft. below ground surface and are in the deepest areas of the lower fill. Coal and coke were observed to depths extending from 0-20 feet above this lower fill area. The source of the elevated levels of metals in the overburden groundwater is believed to be associated with the composition of the historic fill soils that contain coal, coke, ash, cinders, coal fragments, and slag. As identified in Section 3.2 and detailed in the RIR Addendum. A comparison of the analytical results from the most recent (December 2012) overburden groundwater sampling event to those from prior events shows that the concentrations of metals were dramatically lower. In addition, the most recent data suggest that the dramatically lower metals concentrations better represent the actual levels in the overburden groundwater.

The bedrock groundwater sample locations were collected from MWR-101 at the northwest corner of the Site and MWR-102 located near the west central side of the Site. These bedrock wells are paired with overburden monitoring wells MW-101 and MW-102. The lack of metals detected in the bedrock monitoring wells provides an indication that the glacial till deposit overlying the bedrock formation is less permeable than the historical fill soils overlying the glacial till. The bedrock groundwater is generally not impacted at the two locations sampled.

## **5.0 EVALUATION OF REMEDIAL ALTERNATIVES**

### **5.1 DEVELOPMENT OF ALTERNATIVES**

A number of alternatives were evaluated and screened based on the RAOs, cost, implementability, and effectiveness. The screening determined application of a single remedial technology will not be considered sufficient as the sole remedial option based on the physical Site setting and the nature and extent of contamination. As a result, remedial alternatives were combined to provide an effective, implementable, and cost-effective approach to remediating the Site.

The following five remedial alternatives for the Site have been evaluated utilizing the general response actions retained from the initial screening:

### **Alternative 1: No Action with Institutional and Engineering Controls**

- No Remedial Action
- Natural Attenuation and 30 Year Groundwater Monitoring Plan
- Institutional Control to prevent groundwater use
- Engineering Control to control physical access to the site to prevent direct human contact with the historic fill

### **Alternative 2: Removal of All Historic Fill to Meet Track 1 Standards and Placement of Controlled Backfill with Restoration of Ground Surface.**

- Removal of all historic fill to Track 1 unrestricted levels
- Placement of controlled backfill to eliminate the potential for direct human exposure
- Restoration of ground surface
- Post closure compliance groundwater monitoring if required (annual monitoring for 5 years)

### **Alternative 3: Site-Wide Engineered Cover System over Historic Fill with Excavation and Off-Site Disposal of Black Stained Sandy Soils Source Area**

- Site-Wide Engineered Cover System to eliminate the potential for direct human exposure
- Limited excavation associated with cover system installation, requiring Site-wide re-grading and foundation development
- Excavation for Transportation and Off-Site Disposal of black stained sandy soils source area
- Compliance groundwater monitoring (quarterly to annual monitoring for a minimum period of 5 years)
- Engineering and Institutional controls

### **Alternative 4: Site-Wide Engineered Cover System over Historic Fill with Soil Vapor Extraction System for *In Situ* Treatment of Black Stained Sandy Soils Source Area**

- Site-Wide Engineered Cover System to eliminate the potential for direct human exposure
- Soil vapor extraction system for in-situ remediation of Black Stained Sandy soils source area
- Compliance Ground Water Monitoring (quarterly to annual monitoring for a minimum period of 5 years)
- Engineering and Institutional controls

### **Alternative 5: Site-Wide Engineered Cover System over Historic Fill with Chemical Oxidation Remediation of Black Stained Sandy Soils Source Area**

- Site-Wide Engineered Cover System to eliminate the potential for direct human exposure
- Chemical oxidation treatment for in-situ remediation of Black Stained Sandy soils source area
- Compliance Ground Water Monitoring (quarterly to annual monitoring for a minimum period of 5 years)
- Engineering and Institutional controls

A detailed analysis of these five remedial alternatives for remediation and management for the contaminants in the impacted environmental media present at the Site is provided in the following section.

## **5.2 ANALYSIS OF ALTERNATIVES**

The purpose of the following sections is to provide a detailed analysis of several remedial alternatives for managing the contaminants present at the Site. Section 5.3 provides a detailed analysis of each alternative, while Section 5.4 is used to compare the alternatives to each other.

After the description of each alternative in Section 5.3, an assessment of the alternative is made, evaluating the alternative relative to the following criteria:

- Overall Protection of Human Health and the Environment
- Compliance with SCGs
- Long-term Effectiveness & Permanence
- Reduction of Toxicity, Mobility, or Volume
- Short-term Effectiveness
- Implementability
- Cost
- Land Use
- Green Sustainable Remediation (NOTE: While this is not a BCP mandatory criteria, it is recommended to be considered in DER-10 and DER-31).

A summary of each alternative is summarized in Section 5.3.1 through 5.3.5. Cost estimates for each alternative are summarized in Table 1 – Estimated Total Present Worth.

## **5.3 INDIVIDUAL ANALYSIS OF ALTERNATIVES**

### **5.3.1 Alternative 1 - No Action with Engineering and Institutional Controls**

#### **Description of Alternative**

The No Action Alternative is evaluated as a procedural requirement and as a basis for comparison. It allows the Site to remain in an un-remediated state but would be secured with a physical barrier to limit access, such as a fence. This alternative would leave the site in its present condition and would provide minimal protection to human health or the environment.

The No Action Alternative was retained as a basis for comparison of other remedial alternatives. Natural processes, including degradation, dispersion, dilution, adsorption, volatilization, etc., would provide the only source of contaminant removal. As a result, there would be no active reduction in toxicity, mobility, or volume of the contaminants. The cost estimate associated with this alternative includes institutional and engineering control costs and continued monitoring for 30 years. Site engineering controls would include site access restrictions through fencing and signage. The institutional controls would include a groundwater use restriction. Bergmann has estimated that the capital cost to implement the no action alternative will be \$265,000.

## Assessment of Alternative 1

An analysis of the feasibility of the No Action Alternative relative to the Site is summarized in the following table:

**Evaluation of Alternative 1**

Criterion	Discussion
Protection of Human Health & the Environment	<p><i>Advantages:</i></p> <ul style="list-style-type: none"> <li>No Action - Natural attenuation will continue to slowly decrease the concentration of the organic contaminants in soils and groundwater, which would be demonstrated through a long term 30-year groundwater monitoring program.</li> </ul> <p><i>Disadvantages:</i></p> <ul style="list-style-type: none"> <li>Natural attenuation will not decrease or mitigate impact from the concentration of the inorganic (metals) contaminants in soils.</li> <li>May take decades for Site contaminants to attenuate.</li> <li>Remedial objectives not met. Unacceptable exposure levels to workers and community would remain for planned redevelopment only protected by institutional controls and engineering controls.</li> </ul>
Compliance with SCGs	Does not meet SCGs and will not likely meet them for several years (potentially in excess of 30 years).
Long-Term Effectiveness & Permanence	<p><i>Advantages:</i></p> <ul style="list-style-type: none"> <li>No significant advantages other than saving of remedial costs and limiting Site access.</li> </ul> <p><i>Disadvantages:</i></p> <ul style="list-style-type: none"> <li>Not effective in meeting SCGs within a reasonable length of time.</li> <li>Not effective in reducing future exposure levels to human health and the environment.</li> <li>There is no long-term protection from contaminants and redevelopment of Site for public access would not be feasible. Vacant land use and no green remediation.</li> </ul>
Reduction in Toxicity, Mobility, & Volume	<p><i>Advantages:</i></p> <ul style="list-style-type: none"> <li>Eventually, residual organic contamination may reach SCGs.</li> </ul> <p><i>Disadvantages:</i></p> <ul style="list-style-type: none"> <li>All contaminated media remains on Site.</li> <li>Reduction in toxicity, mobility, or volume of organic contaminants through natural attenuation is very slow (probably over 30 years).</li> <li>There would be no reduction of inorganic (metals) contaminants through natural attenuation.</li> </ul>
Short-Term Effectiveness	<p><i>Advantages:</i></p> <ul style="list-style-type: none"> <li>Site activity is limited to erection of the fence to prevent access to the Site. There is minimal to no increased risk to workers other than during fence construction, and no risk to the community or the environment, which would need to be managed during the implementation of fence erection as compared to the other remedial alternatives. (i.e. fugitive dust emissions, storm water management, open trench hazards, and hauling of contaminated soils through residential communities).</li> </ul> <p><i>Disadvantages:</i></p> <ul style="list-style-type: none"> <li>Offers no increased protection to human health or the environment.</li> </ul>
Implementability	<p><i>Advantages:</i></p> <ul style="list-style-type: none"> <li>Easily implemented.</li> </ul> <p><i>Disadvantages:</i></p> <ul style="list-style-type: none"> <li>Offers no increased protection to human health or the environment.</li> </ul>



Criterion	Discussion
Costs	<ul style="list-style-type: none"> <li>• Capital costs - \$40,000</li> <li>• Annual costs (groundwater monitoring and repairs to fence)- \$14,637</li> <li>• Present worth - \$265,007</li> </ul>

### 5.3.2 Alternative 2 - Removal of All Historic Fill to Meet Track 1 Standards and Placement of Controlled Backfill with Restoration of Ground Surface.

#### Description of Alternative

This alternative is a soil removal alternative with transportation and disposal off-site to achieve Track 1 Unrestricted SCOs. Under this alternative, excavated soils would be excavated within the VOA Site to the original ground surface (pre-landfilling) and disposed of at a permitted off-site landfill facility. The proposed excavation area would include the entire Site area. The historic fill soils landfilled in the ravine would be excavated to the natural ground or bedrock surface. Subsequent to this massive excavation project, and confirmatory samples collected to ensure removal of the contaminated media, import of clean soils would be required to serve as structural fill to restore the Site to the existing ground surface. All soils excavated would be transportation off-site for disposal. Contaminated groundwater encountered in the excavation would be managed either onsite or offsite and discharged in accordance with discharge limits established by NYSDEC. After remediation the Site could be used for residential, commercial, or industrial uses.

In order to verify successful Track 1 Site remediation was achieved, it would be necessary to perform confirmatory sampling at the bottom of and the side walls of the excavation to confirm Track 1 standards were achieved.

It is anticipated that the excavation of impacted soils, backfilling, and site restoration would require 1 to 2 years to complete.

Under Alternative 2, an extensive dewatering system would be required to facilitate soil excavation at depths below the groundwater table, especially given the permeable historic fill soils beneath the Site. Contamination was observed in on-site groundwater. Therefore, groundwater extracted from the Site during the remedial action would need to be properly managed. It has been assumed that the extracted groundwater can be treated using sediment filtration and granular activated carbon (GAC) to remove the contaminants. The exact depth of the excavation and the location of the dewatering wells, and type of shoring system would be determined during the design phase, should this alternative be selected as a remedy for the Site.

Assuming that all historic fill soils would be removed to the original ground surface, an excavation of this magnitude would result in the generation of approximately 144,000 yds<sup>3</sup> or on the order of 221,760 tons of historic fill soil for off-site disposal. The historic fill soil generated by the excavation activities would also need to be characterized for disposal prior to transportation to a permitted disposal facility. Approximately 221,760 tons of clean granular soil would need to be transported to the Site and placed as structural backfill (compacted soil) to restore the Site to the existing ground surface elevation.

To effectively dewater the excavation, Bergmann has estimated that approximately ten extraction wells would be required. It has been assumed that the extracted groundwater can be treated on-site

using sediment filtration and granular activated carbon (GAC) to remove potential contaminants. If the groundwater cannot be treated on-site using sediment filtration and a GAC system, then it will be managed off-site and discharged in accordance with discharge limits established by the NYSDEC and Monroe County Pure Waters at a water treatment plant or recycling facility.

## Assessment of Alternative 2

The following table provides a summary of the detailed assessment for the **Removal of All Contaminated Soils to Meet Track 1 Standards and Placement of Controlled Backfill with Restoration of Ground Surface.**

**Evaluation of Alternative 2**

Criterion	Discussion
Protection of Human Health & the Environment	<p><i>Advantages:</i></p> <ul style="list-style-type: none"> <li>Removal of all Site soils that contain contaminants to Track 1 levels to prevent any future potential exposure risks to human health and the environment after remediation is complete.</li> <li>Achievement of cleanup goals that will provide the highest protection of human health and the environment.</li> </ul> <p><i>Disadvantages:</i></p> <ul style="list-style-type: none"> <li>Alternative would not be cost effective and would disrupt the current Volunteers of America's Human Services Operations due to dust exposure concerns, elevated noise levels and disruption of Site traffic flow during year and a two year long excavation and backfill process.</li> </ul>
Compliance with SCGs	Remedial objectives and compliance with SCGs would be met following remediation because all contaminated media will be removed and replaced with clean soil.
Long-Term Effectiveness & Permanence	<p><i>Advantages:</i></p> <ul style="list-style-type: none"> <li>Effective. Threats posed by Site contaminants removed from Site.</li> <li>Remedy is permanent because soils are disposed off-site and replaced with clean soils. Land can be redeveloped.</li> </ul> <p><i>Disadvantages:</i></p> <ul style="list-style-type: none"> <li>Contaminated soils relocated rather than treated. Highest energy cost.</li> <li>Lengthy dust exposure risk during long term excavation activities.</li> </ul>
Reduction in Toxicity, Mobility, & Volume	<p><i>Advantages:</i></p> <ul style="list-style-type: none"> <li>Toxicity, mobility, and volume of contaminants at the Site are reduced in a relatively short-time frame.</li> </ul> <p><i>Disadvantages:</i></p> <ul style="list-style-type: none"> <li>Increased potential for contaminant mobility from dust and vapors during excavation would need to be managed.</li> <li>The overall volume and toxicity of the contaminants is reduced on-site but not from existence since they are transferred to a disposal facility.</li> </ul>

Criterion	Discussion
Short-Term Effectiveness	<p><i>Advantages:</i></p> <ul style="list-style-type: none"> <li>Highest degree of protection of human health and the environment, since contaminated soils would be eliminated at the Site.</li> </ul> <p><i>Disadvantages:</i></p> <ul style="list-style-type: none"> <li>Has potential to generate significant fugitive dust emissions and some limited volatile emissions to air for a lengthy period of time.</li> <li>Engineering controls required to protect workers and the public, including adjacent day care center children, during intrusive excavations would need to be implemented and may not be for a lengthy period of time.</li> <li>Storm water runoff would need to be managed during lengthy excavation. Large amounts of water from dewatering efforts would need to be managed.</li> </ul> <p><i>Disadvantages:</i></p> <ul style="list-style-type: none"> <li>Large volume of excavated soil would result in increased truck traffic on-site and on Lake Avenue.</li> <li>This alternative would limit some of Volunteers of America's outdoors daycare operations / thrift store operations and therefore would disrupt their adjacent Human Service operations at 214 Lake Avenue.</li> </ul>
Implementability	<p><i>Advantages</i></p> <ul style="list-style-type: none"> <li>No long-term maintenance, easement or utilities required.</li> </ul> <p><i>Disadvantages:</i></p> <ul style="list-style-type: none"> <li>Implementing a large scale excavation operation of this magnitude would be similar to an open mining operation. A large scale dewatering system would need to be implemented to allow for excavation to depths below the groundwater table and would result in very large amounts of water that would need to be managed by storage, treatment, and/or proper discharge. Removal of contaminated media below 15 feet would be difficult.</li> <li>Significant engineering controls required during excavation to reduce exposure to humans and the environment from fugitive dust, deep excavation hazards, storm water runoff control, etc.</li> <li>Removing large quantities of soil off-site and importing clean fill would result in significantly increased truck traffic through local communities.</li> <li>The cost to perform this type of remedial alternative is prohibitive.</li> </ul>
Costs	<ul style="list-style-type: none"> <li>Capital costs - \$24,238,000</li> <li>Annual cost - \$0.00</li> <li>Present worth - \$24,238,000</li> </ul>

The excessively high costs for the Volunteer to remove the large quantity of fill material requiring off-site disposal and conduct a lengthy, simultaneous large scale dewatering effort, followed by import of a large quantity of clean granular soils (backfill) does not provide a significant environmental benefit in this urban environment. There are other preferable alternatives, which do not create as many immediate exposure impacts as this Track 1 remedy. This would also be the least green remedy, as it would cause significant heavy-duty construction equipment use and truck traffic (use of fuel) over a long period of time and cause the most potential dust exposure.

### 5.3.3 Alternative 3 –Site-Wide Engineered Cover System over Historic Fill with Excavation and Off-Site Disposal of Black Stained Sandy Soils Source Area

#### Description of Alternative

This alternative is a Track 4 remedy including removal of a hot spot source area and installation of a Site-wide cover system that consists predominantly of asphalt. See description below.

The Site-wide engineered cover system of at least two feet over the historic fill will consist of a combination of granular fill materials and asphalt in accordance with NYSDEC DER-10 and geotechnical requirements. The engineering design will take into account that the Site is a landfill that may settle in order to avoid significant long term environmental and engineering maintenance requirements that would require correction and replacement of the cover system. As part of the evaluation of estimated cost for the Site wide engineered cover system, it is assumed that approximately 90% of the cover system would be the proposed site-wide asphalt surface cover system and approximately 9% existing pavement (asphalt) roadway/parking areas and 1% would consist of the limited existing grass landscape and grass island in the existing parking lot/road way. The existing pavement roadway / parking area has some cracks in the pavement that will be sealed as part of this remedy.

The Site-Wide Engineered Cover System will include the following cover types:

1. Soil Cover – existing lawn and landscaped island area. Existing soils 24-inches thick with grass cover (approximately 1% of the Site).
2. Existing Pavement Roadway/Parking Cover – Existing pavement constructed over approximately 9% of the site with gravel sub-base and 4-inches of asphalt. These areas of the Site were constructed in 1998 when VOA redeveloped the adjoining facility that is now the Human Service Complex. The pavement in these areas has a gravel sub-base and 4-inches of existing pavement. Some cracks have developed and will be sealed as part of the remedy.
3. Soil and Asphalt Cover – This is the proposed cover to be constructed on approximately 90% of the site and includes 18-inches of granular sub-base and 4-inches of asphalt. A demarcation marker will be placed over the historic fill and or over on-Site bio-cell soils/soil pile soil may be used for backfilling during the grading activities under the cover system.

The objective of the engineered cover system would be to:

- (1) Minimize the potential for direct human exposure;
- (2) Minimize potential for surface run off erosion and off-site migration of contaminated soils by wind and control drainage flow.
- (3) Significantly reduce the amount of precipitation infiltration through the impacted historic fill soils and into the overburden groundwater table.

As a result of the Site-wide engineered cover system, there should be less contact of infiltrating surface run off (water form precipitation) with historic fill soils, and, therefore, a potential to reduce impact to the groundwater quality at the Site. When the cover system is breached in the future as a

result of required subsurface work, the excavation area will be managed pursuant to the Site Management Plan (SMP).

It should be noted that for cost estimation purposes, it was assumed that removal and off-site disposal of some surface soils may be required due to re-grading and drainage / storm water improvements. Long-term institutional and engineering controls, including a Site Management Plan and environmental easement, will prevent direct contact with contaminated soils beneath the engineered cover system.

In addition, alternative 3 includes an excavation and off-site disposal of the Black Stained Sandy Soil source area, which will be performed to remove this limited area of the historic fill with different physical and chemical characteristics when compared to the rest of the historic fill. These characteristics include: elevated organic vapors, black stained color, sandy silt soils, creosote odors, and elevated concentrations of mid-range diesel organics (2,200 ppm). Soils in this area have the highest contaminant levels on the Site (source area). This area is approximately 35 ft. X 35 ft. and extends to depths greater than 20 feet. VOAs remediation contractor will prepare an Excavation Work Plan and implement this plan for this deep excavation. The approximate quantity is 1,000 cubic yards or approximately 1,500 tons of historic fills soil. It should be noted that the volume of soil to be excavated under this alternative is estimated at this time based on RI test pit excavations and laboratory testing. The actual quantity would be finalized in the field during Site excavation activities. Dewatering is not anticipated during the soil source removal excavation activities under this alternative. However, shoring will be required during excavation activities to the 20 foot depth.

An underground storm water detention system will be installed near Ambrose Street below the existing ground surface after removal of the Black Stained Sandy Soil source area. The on-site historic fill soils that will be excavated to install the storm water detention system will be used to backfill this excavation.

Alternative 3 would also require the use of institutional controls (ICs) and engineering controls (ECs) to protect human health and the environment against exposure to residual contaminants under the cover system. ICs would include imposition of an environmental easement to restrict land use and prohibit the use of groundwater beneath the Site. ICs and ECs will be documented in the SMP. The SMP will be prepared and implemented through the end of active remediation and during future intrusive (excavation) activities below the demarcation marker. Soils that need to be excavated from the Site during future construction activities would be required to be handled in accordance with the SMP's Soil Management Plan. The primary EC would be the engineered cover system, which must be inspected and maintained in accordance with the SAP. These controls would be memorialized by a formal environmental easement, which will run with the land and will required all future owners and operators of the site to comply with the Site-wide ECs and ICs.

Specifically, the Soil Management Plan in the SMP would be prepared to:

- (1) identify known locations of any remaining impacted soil at the site;
- (2) establish appropriate controls for future disturbances of site soil;
- (3) set forth the inspection and maintenance activities for the site-wide cap;
- (4) establish the annual monitoring protocols and frequencies for Site-wide maintenance and
- (5) establish a sampling and analysis groundwater monitoring program.



The SMP would be a means to address potential future soil excavation if and when required to occur. In addition, an environmental easement would require all future owners and operators to comply with the SMP and restrict the Site use to ground floor commercial and prohibit groundwater use.

Since contaminants will remain at the Site under the cover system, it will also be necessary to institute a groundwater monitoring program for five years after the active remedial activities are complete. The frequency of groundwater monitoring will be quarterly for at least the first two years after which time a potential reduction in frequency to annual monitoring will be evaluated. After five years of groundwater monitoring is complete, the potential for discontinuation of the groundwater monitoring program will be evaluated. During the design, the need to install new wells or use the existing wells will be evaluated. It should be noted that the estimated cost for Alternative 3 includes re-grading and placement of an engineered cover system over the Site (approximately 3 acres) is only an estimate to be refined in the Remedial Action Work Plan.

### Assessment of Alternative 3

The following	<i>Discussion</i>
Protection of Human Health & the Environment	<p><i>Advantages:</i></p> <ul style="list-style-type: none"> <li>• The site contaminants will be isolated, preventing direct human contact and off-site migration of soils by erosion and windblown soil particles.</li> <li>• Site-wide cover system will reduce the cross-media migration of contaminants of concern from the historic fill soils into the overburden groundwater by limiting the infiltration of precipitation (surface run off).</li> <li>• The Excavation Work Plan contained in the future Site Management Plan will provide guidance for contactors and developers for proper management of future exposed contaminated soils during excavation work to minimize and protect potential exposure to human health and the environmental receptors.</li> <li>• The black stained sandy soils source area will be removed from the Site and will substantially reduce the potential impact to human health and the environment. Source area soil removal will also substantially reduce the potential for Vapor intrusion in future Site buildings.</li> <li>• Long-term protection from contaminants and redevelopment of the Site for public access is feasible as a result of implementation of the cover system and long term ICs and ECs.</li> </ul>
Protection of Human Health & the Environment (etc.)	<p><i>Disadvantages:</i></p> <ul style="list-style-type: none"> <li>• Natural attenuation will not decrease the concentration of the metals (inorganic contaminants) in soils or groundwater at the Site after implementation of this alternative.</li> <li>• May take decades for Site contaminants in fill material to attenuate.</li> </ul>
Compliance with SCGs	<p><i>Advantages:</i></p> <ul style="list-style-type: none"> <li>• Is protective of human health and the environment under a Track 4 restricted residential or commercial remedial scenario since the environmental groundwater receptor and human receptors are protected by the cover system and the most contaminated source area is removed.</li> </ul> <p><i>Disadvantages:</i></p> <ul style="list-style-type: none"> <li>• Majority of contaminants will remain in historic fill soil beneath the covered area. Most COCs will remain in groundwater some may attenuate over time and</li> </ul>

The following	Discussion
Long-Term Effectiveness & Permanence	<p><i>Advantages:</i></p> <ul style="list-style-type: none"> <li>Placing a site-wide cover system over the contaminated historic fill soils would reduce human exposure to the COCs.</li> <li>Removal of the black stained sandy soils would result in permanent reduction of the amount of contaminated historic fill on Site and significant reduction of potential vapor intrusion issues in future Site buildings. Land use with green remediation.</li> </ul> <p><i>Disadvantages:</i></p> <ul style="list-style-type: none"> <li>Most COCs will remain in the groundwater due to Site-wide historic fill for an extended period of time.</li> <li>Land use controls (IC) would be necessary to ensure long-term protection for human health and the environment.</li> </ul>
Reduction in Toxicity, Mobility, & Volume	<p><i>Advantages:</i></p> <ul style="list-style-type: none"> <li>Eventually, SVOC and metals contamination in groundwater would stabilize and should not increase in concentration.</li> <li>The soil in the area of the black stained sandy soil source area would be removed, reducing the volume of contaminants at the Site and also reducing potential vapor intrusion issues for the future Site building.</li> </ul> <p><i>Disadvantages:</i></p> <ul style="list-style-type: none"> <li>Majority of contaminated media remains on Site.</li> <li>Reduction in toxicity, mobility, or volume of metals and SVOC contaminants in remaining soils through natural attenuation is relatively low and slow.</li> <li>Contaminated soil is moved to another disposal location.</li> <li>There would be no reduction of inorganic (metals) contaminants through natural attenuation.</li> </ul>
Short-Term Effectiveness	<p><i>Advantages:</i></p> <ul style="list-style-type: none"> <li>Development for public access and Site reuse is possible in a relatively short time frame and without significant Site disruption or minimal potential for exposure to neighbors from dust and organic vapors.</li> </ul> <p><i>Disadvantages:</i></p> <ul style="list-style-type: none"> <li>ECs and ICs would still need to be implemented to reduce human and environmental exposures but less short term impacts since there will be limited excavation.</li> </ul>
Implementability	<p><i>Advantages:</i></p> <ul style="list-style-type: none"> <li>Readily implemented.</li> <li>Limited soil quantity to be transported off-site, dewatering system not required for soil removal excavation.</li> <li>Minimal maintenance after active remediation and redevelopment</li> </ul> <p><i>Disadvantages:</i></p> <ul style="list-style-type: none"> <li>Long-term groundwater monitoring program would be required.</li> </ul> <p><i>Disadvantages:</i></p> <ul style="list-style-type: none"> <li>ECs and ICs required during and after physical remediation are competed.</li> <li>Long-term groundwater monitoring program would be required.</li> </ul>
Costs	<ul style="list-style-type: none"> <li>Capital costs - \$2,489,343</li> <li>Annual cost - \$9,435</li> <li>Present worth - \$2,634,382</li> </ul>

Due to the fact that contamination would remain in place under this alternative, a SMP would need to be prepared to detail the IC and EC future Site monitoring requirements as well as the procedures that would be developed to protect the remedy and minimize human exposure during future intrusive Site activities. This remedy would have a carbon footprint impact due to temporary

truck traffic associated with the truck traffic for the source removal part of the remedy. However, this impact is outweighed by the environmental benefits associated with source removal.

The following assumptions have been made regarding Alternative 3:

- It is assumed that bio-cell soil material and soil piles (soil stock piles) can be used as backfill at the Site under the cover system. In addition soils removed from future utility installations would be placed below the demarcation marker and the area of the cover system that is impacted or disturbed will be repaired to meet the cover system detailed in this plan and the SMP.
- Costs assume that historic fill surface soils may require some removal and re-grading for installation of the cover system.
- Grading / drainage plans and the storm water detention system were prepared by Passero Associates of Rochester, New York and are attached to this RAWP. The design for the Site-Wide Engineered Cover System was also completed by Passero Associates.
- The thickness of the cover system will be a 2 foot minimum soil and 4-inch minimum asphalt to meet DER-10 requirements. The majority of the cover system will be Soil and Asphalt that includes approximately 18-inches of compacted granular soil and 4-inches of Asphalt (pavement) to maintain the integrity of the cover system for reduced frequency of potential future settlement and or cracks.

#### **5.3.4 Alternative 4- Site-Wide Engineered Cover System over Impacted Soils with Soil Vapor Extraction System for *In Situ* Treatment of Black Stained Sandy Soils Source Area**

##### **Description of Alternative**

Alternative 4 is similar to Alternative 3 in that a site-wide engineered cover system will be installed and a soil vapor extraction system will be implemented for In Situ (in-place) on-site treatment instead of physical soil removal for off-site disposal of the Black Stained Sandy soils source area. The Site-wide engineered cover system to be installed for Alternative 4 is to isolate the impacted historic fill soils and for the same protection of human health and environment objectives as described for Alternative 3.

Alternative 4 also includes a soil vapor extraction (SVE) system for the removal of volatile organic compounds and SVOCs from the area identified as Black Stained Sandy soil source area. A network of 18 soil vapor extraction wells would be installed in the Black Stained Sandy soil source area and connected to a vacuum blower motor to provide the design vacuum required to remove the contaminants over time. The extraction wells are installed to the design depth that is determined based on the depth of the groundwater table and the vertical extent of impacts. Each extraction well is located in the impacted area based on the spacing required from determination of the effective extraction well radius of influence. The size of the Black Stained Sandy soil source area is approximately 35 ft. X 35 ft. and extends deeper than 20 feet. These historic fill soils have elevated organic vapors, which were detected during test pit explorations. A Site Management Plan, which will include ICs and ECs, and an environmental easement will also be prepared and recorded, to be implemented by current and future owners, developers, contractors and Site operators for management of potential exposures to human health and the environmental receptors. This remedy may create a lower short-term carbon footprint impact than Alternative 3. However, there is a long-term carbon footprint impact. Since, electricity is required to operate the SVE system.

## Assessment of Alternative 4

The following table provides a summary of the detailed assessment for a **Site-Wide Engineered Cover System Over Impacted Soils with Soil Vapor Extraction System for *In Situ* Treatment of Black Stained Sandy Soils Source Area.**

### Evaluation of Alternative 4

Criterion	Discussion
Protection of Human Health & the Environment	<p><i>Advantages:</i></p> <ul style="list-style-type: none"> <li>The Site contaminants will be isolated, preventing direct human direct contact and off-site migration of soils by erosion and windblown soil particles.</li> <li>Site-wide engineered cover system will reduce the cross-media migration of contaminants of concern from the historic fill soils into the overburden groundwater by limiting the infiltration of precipitation (surface run off).</li> <li>The Excavation Work Plan contained in the future Site Management Plan will provide guidance for contractors and developers for proper management of future exposed contaminated soils during excavations that potential exposure to human health and the environmental receptors are minimized and protected.</li> <li>The Black Stained Sandy soils source will be treated <i>In Situ</i> and concentrations of volatile organic compounds and SVOC will be reduced at a rate quicker than natural attenuation, thus decreasing the time to achieve protection of human health and environmental receptors.</li> <li>Long-term protection from COCs and VOA's redevelopment of the Site for public access would be feasible.</li> <li>Potential worker exposures during the implantation of this alternative are less than alternatives 2 and 3. Since, this alternative is implemented without an excavation for soil removal where exposure risks to impacted soils during excavation are higher when compared to installation of a soil vapor extraction system (<i>in-situ</i>) that are lower for workers.</li> </ul> <p><i>Disadvantages:</i></p> <ul style="list-style-type: none"> <li>Natural attenuation will not decrease the concentration of the metals (inorganic contaminants) in soils or groundwater at the Site after this alternative is implemented.</li> </ul>
Compliance with SCGs	<p><i>Advantages:</i></p> <ul style="list-style-type: none"> <li>Is protective of human health and the environment for a Track 4 remedial scenario.</li> </ul> <p><i>Disadvantages:</i></p> <ul style="list-style-type: none"> <li>Majority of contaminants will remain in historic fill soil beneath the site –wide engineered cover system.</li> <li>Most COCs will remain in groundwater.</li> </ul>
Long-Term Effectiveness & Permanence	<p><i>Advantages:</i></p> <ul style="list-style-type: none"> <li>Placing a site-wide engineered cover system over the contaminated historic fill soils would reduce human exposure to the COCs. A limited portion of historic fill (Black Stained Sandy Soils source area) would be remediated for VOCs and the majority of SVOCs with the <i>In Situ</i> soil vapor treatment system.</li> <li>Remedy is permanent in area of <i>In Situ</i> treatment system because majority of contaminants are <i>destroyed</i> rather than transferred to a disposal facility.</li> <li>Reduces the amount of organic vapors contaminants that could potentially migrate off-site or cause potential vapor intrusion issues in future Site buildings.</li> <li>Land can be redeveloped.</li> </ul>

Criterion	Discussion
	<p><i>Disadvantages:</i></p> <ul style="list-style-type: none"> <li>• Most COCs will remain in the historic fill soils below the engineered cover system and residual VOCs, SVOCs, metals will remain in the Black Stained Sandy Soil source area.</li> <li>• Most contaminants will remain in the groundwater due to Site-wide metals and SVOC contamination.</li> <li>• Enhanced <i>In Situ</i> treatment system will require long term operation and maintenance (O&amp;M) and electrical use. High electric energy cost.</li> <li>• ECs and ICs would be necessary to ensure long-term protection of human health.</li> </ul>
<p>Reduction in Toxicity, Mobility, &amp; Volume</p>	<p><i>Advantages:</i></p> <ul style="list-style-type: none"> <li>• Eventually, COCs in groundwater would stabilize and should not increase in concentration.</li> <li>• The Black Stained Sandy Soil source area would be treated, reducing the volume of and concentration of contaminants at the Site.</li> <li>• The potential vapor intrusion issues for the future VOA Site building and off-site migration of fewer contaminants. The volume of contaminants in the Black Stained Sandy soil source area is reduced in place on-site rather than transferred off-site for disposal with source area (elevated) concentrations.</li> </ul> <p><i>Disadvantages:</i></p> <ul style="list-style-type: none"> <li>• Contaminated media remains on Site under the Site-Wide engineered cover system. Reduction in toxicity, mobility, or volume of organic compounds and SVOC contaminants in remaining soils through natural attenuation is very slow and may take decades.</li> <li>• There would be no reduction of inorganic (metals) contaminants in the historic fill soils and groundwater at the Site.</li> </ul>
<p>Short-Term Effectiveness</p>	<p><i>Advantages:</i></p> <ul style="list-style-type: none"> <li>• Development for public access and Site reuse would be possible without significant Site disruption or exposure to adjoining properties from dust.</li> </ul> <p><i>Disadvantages:</i></p> <ul style="list-style-type: none"> <li>• ECs and ICs would need to be implemented to reduce potential human health and environmental exposures but less short term impacts. Since, there will be extraction wells drilled in place of an open excavation for the remediation of the Black Stained Sandy Soil source. Monthly and annual O&amp;M required for the soil vapor extraction system.</li> </ul>
<p>Implementability</p>	<p><i>Advantages:</i></p> <ul style="list-style-type: none"> <li>• Readily implemented.</li> <li>• Large excavations are not required, no soil to be transported off-site, dewatering system not required.</li> </ul> <p><i>Disadvantages:</i></p> <ul style="list-style-type: none"> <li>• ECs and ICs required during and after physical remediation are completed.</li> <li>• Energy consumption will be high due electric power required to operate the Soil vapor extraction system for several years.</li> <li>• Constructions of surface structures are required to house soil vapor extraction equipment that may impact future redevelopment of the Site.</li> <li>• Long-term Routine operation and maintenance (O&amp;M) will be required for the soil vapor extraction system.</li> <li>• Active remediation (soil vapor extraction) will be on-going during the construction and after completion of the VOA's redevelopment.</li> <li>• Long-term groundwater monitoring program would be required.</li> </ul>



Criterion	Discussion
Cost	<ul style="list-style-type: none"> <li>• Capital costs – \$2,180,638</li> <li>• Annual costs - \$18,335</li> <li>• Present worth - \$2,462,492</li> </ul>

The following assumptions have been made regarding Alternative 4:

- It is assumed that bio-cell soil material and soil piles can be used as backfill at the Site under the engineered cover system. In addition soils removed from future utility installations would be placed below the engineered cover system.
- Costs assume that historic fill surface soils will require some removal and re-grading for installation storm water detention system and the engineered cover system.
- The thickness of the cover system will be 2 feet to maintain the integrity of the cover system and to reduce the frequency of potential future settlement and cracks.
- Costs assume that a two foot Site-Wide cover system will be constructed over the entire Site and an in-situ soil vapor extraction system will be installed in the Black Stained Sandy soil source area to remove volatile organic and SVOC vapors.
- It is assumed that the SVE system will operate for 10 years and can be purchased for costs described in Table 1.
- The Site will be graded to enhance preferred drainage with minimal additional excavation, install the cover system and storm water detention system in a manner so that the entire Site will be covered with the cover system and will be maintained to reduce settlement and future pavement surfaces.

### 5.3.5 Alternative 5- Site-Wide Engineered Cover System over Impacted Soils with Chemical Oxidation Remediation of Black Stained Sandy Soils Source Area

#### Description of Alternative

Alternative 5 is similar to Alternatives 3 and 4 with respect to the placement of site-wide engineered cover system. The Site-wide engineered cover system to be installed for Alternative 5 is to isolate the impacted historic fill soils and for the same protection of human health and environment objectives as described for Alternatives 3 and 4. Injection of a chemical oxidation slurry in treatment boreholes would be implemented for In Situ (in-place) on-site treatment in the Black Stained Sandy soil source area instead of the In Situ soil vapor extraction system described in Alternative 4 and in place of the excavation with off-site disposal of the Black Stained Sandy soils source area described in Alternative 3. Long-term ECs and ICs requirements presented in a SMP with an environmental easement will also be included in Alternative 5.

This alternative is primarily a Site-wide engineered cover system alternative with injection of chemical oxidation slurry for the *In Situ* remediation of the Black Stained Sandy soil source area near the northern end of the site. This alternative includes site wide grading to the extent required to install the Site-Wide engineered cover system as described in Alternatives 3. A network of treatment boreholes (injection points) will be drilled into the Black Stained Sandy Soil source area to depths of approximately 20 feet. The design dose of chemical oxidation slurry will be mixed and injected into each borehole. The chemical oxidation slurry makes contact with the COC in the soils and chemically reduces the concentrations of volatile organic compounds and SVOCs. The slurry will be introduced into the subsurface from approximately 6 feet below the ground surface to a total depth of approximately 20 feet. The design treatment borehole spacing and number of boreholes is based on

the concentration and soil permeability form the RI. Therefore, 24 treatment boreholes on 10-foot centers are estimated to provide the correct delivery of the slurry. The proposed slurry design mixture is a 4 % solution containing 10 lbs. of RegenOx part A and 20 lbs. of RegenOx part B per vertical foot. ECs and ICs will also be implemented as described in the SMP and Environmental Easement to provide future developers, contractors, and operators with guidance for management of on-going remediation requirements for protection of human health and environmental receptors. This remedy creates a lower carbon footprint impact than Alternatives 3 and 4. However, there is a low likelihood it will be successful in achieving the remedial goal of source removal.

### Assessment of Alternative 5

The following table provides a summary of the detailed assessment for **Site-Wide Engineered Cover System over Impacted Soils with Chemical Oxidation Remediation of Black Stained Sandy Soils Source Area.**

#### Evaluation of Alternative 5

Criterion	Discussion
Protection of Human Health & the Environment	<p><i>Advantages:</i></p> <ul style="list-style-type: none"> <li>• The Site contaminants will be isolated, preventing direct human direct contact and off-site migration of soils by erosion and windblown soil particles.</li> <li>• Site-wide engineered cover system will reduce the cross-media migration of contaminants of concern from the historic fill soils into the overburden groundwater by limiting the infiltration of precipitation (surface run off).</li> <li>• The Excavation Work Plan contained in the future Site Management Plan will provide guidance for contractors and developers for proper management of future exposed contaminated soils during excavations that potential exposure to human health and the environmental receptors are minimized and protected.</li> <li>• Natural attenuation will slowly decrease the concentration of the dissolved SVOC contaminants in groundwater after the engineered cover system is constructed and chemical oxidation treatment is applied.</li> <li>• The Black Stained Sandy soils source will be treated In Situ and concentrations of volatile organic compounds and SVOC will be reduced at a rate quicker than natural attenuation, thus decreasing the time to achieve protection of human health and environmental receptors. Long-term protection from COCs and VOA's redevelopment of the Site for public access would be feasible.</li> <li>• Potential worker exposures during the implantation of this alternative are less than alternatives 2, and 3. Since, there this alternative is implemented without an excavation for soil removal where exposure risks are highest for workers.</li> <li>• Potential fugitive dust emissions are less likely to occur at the adjoining properties (including day care children center) from installation of treatment boreholes when compare to Alternatives 2 and 3.</li> </ul>

Criterion	Discussion
Protection of Human Health & the Environment	<p><i>Disadvantages:</i></p> <ul style="list-style-type: none"> <li>• Natural attenuation will not decrease the concentration of the metals (inorganic contaminants) in soils or groundwater at the Site after this alternative is implemented. Since, metals do not naturally attenuate and are not reduced by chemical oxidation treatments. May take years for Site SVOC contaminants in historic fill soils to attenuate.</li> <li>• May take years for Site SVOC contaminants in fill material to attenuate.</li> <li>• Difficulty regarding complete contact of the chemical oxidation slurry with impacted soils may result in pockets of impacted soils not treated by this technology.</li> </ul>
Compliance with SCGs	<ul style="list-style-type: none"> <li>• Is protective of human health and the environment for a Track 4 remedial scenario.</li> </ul>
Long-Term Effectiveness & Permanence	<p><i>Advantages:</i></p> <ul style="list-style-type: none"> <li>• Placing a site-wide engineered cover system over the contaminated historic fill soils would reduce human exposure to the COCs. A limited portion of historic fill (Black Stained Sandy soils source area) would be remediated for VOCs and the majority of SVOCs with the <i>In Situ</i> chemical oxidation treatment application.</li> <li>• Remedy is permanent in area of <i>In Situ</i> treatment system because majority of contaminants are <i>destroyed</i> rather than transferred to a disposal facility but unlike Alternative 4 this would be accomplished in a longer time frame.</li> <li>• Significantly reduces the amount of organic vapors contaminants that could potentially migrate off-site or cause potential vapor intrusion issues in future Site buildings.</li> <li>• No energy consumption due to <i>In Situ</i> chemical oxidation treatment application. Land can be redeveloped.</li> </ul> <p><i>Disadvantages:</i></p> <ul style="list-style-type: none"> <li>• Most COCs will remain in the historic fill soils below the engineered cover system and residual VOCs, SVOCs, metals will remain in the Black Stained Sandy Soil source area.</li> <li>• Most contaminants will remain in the groundwater due to Site-wide metals and SVOC contamination.</li> <li>• ECs and ICs would be necessary to ensure long-term protection of human health and the environment.</li> <li>• Subject to a bench scale test, at least two applications of Chemical oxidation would be required to achieve the remedy objectives for protection of human health and the environmental receptors. [NOTE: bench scale testing has not been performed and cost estimate in Table 1 only includes two applications].</li> </ul>
Reduction in Toxicity, Mobility, & Volume	<p><i>Advantages:</i></p> <ul style="list-style-type: none"> <li>• Eventually, SVOCs and metals contamination in groundwater would stabilize and should not increase in concentration.</li> <li>• The soil in the area of the black stained sandy soils would be treated, reducing the volume of contaminants at the Site, reducing potential vapor intrusion issues for the future Site building off-site migration of fewer contaminants.</li> <li>• The concentration of contaminants in the area of black stained sandy soil is reduced in place rather than transferred off-site at higher concentrations.</li> </ul>

Criterion	Discussion
	<p><i>Disadvantages:</i></p> <ul style="list-style-type: none"> <li>Contaminated media remains on Site under the Site-Wide Cover System. Reduction in toxicity, mobility, or volume of SVOC and organic contaminants in remaining soils through natural attenuation is very slow.</li> <li>There would be no reduction of inorganic (metals) contaminants at the Site</li> <li>Pockets of impacted soils may remain due to oxidant delivery and contact issues.</li> </ul>
Short-Term Effectiveness	<p><i>Advantages:</i></p> <ul style="list-style-type: none"> <li>Development for public access and Site reuse would be possible without long-term significant Site disruption.</li> </ul> <p><i>Disadvantages:</i></p> <ul style="list-style-type: none"> <li>ECs and ICs would need to be implemented to further reduce potential exposures to human health and environmental receptors.</li> <li>There would be temporary exposure to fugitive dust. Since remedy requires drilling of boreholes. However, potential exposures from fugitive dust emission would be less likely when compared to alternatives 2 and 3.</li> </ul>
Implementability	<p><i>Advantages:</i></p> <ul style="list-style-type: none"> <li>Readily implemented.</li> <li>Large excavations are not required, no soil to be transported off-site, dewatering system not required.</li> <li>Long-term operation and maintenance is not required.</li> <li>No construction of surface structures or sheds required to house remedial equipment that may impact future redevelopment of the Site.</li> <li>No remedial equipment needed to remain on Site after the chemical oxidation application.</li> </ul> <p><i>Disadvantages:</i></p> <ul style="list-style-type: none"> <li>Short term ECs and ICs required during Site remediation activities properly manage fugitive dust and storm water runoff issues.</li> <li>Long Term ECs and ICs required after Site remediation.</li> <li>Long-term groundwater monitoring program would be required.</li> </ul>
Cost	<ul style="list-style-type: none"> <li>Capital costs – \$2,203,563</li> <li>Annual costs - \$9,435</li> <li>Present worth - \$2,348,602</li> </ul>

The following assumptions have been made regarding Alternative 5:

- It is assumed that bio-cell soil material and soil piles can be used as backfill at the Site under the engineered cover system. In addition soils removed from future utility installations would be placed below the engineered cover system.
- Costs assume that historic fill surface soils will require some removal and re-grading for installation of the engineered cover system.
- The thickness of the cover system will be a minimum of 2 feet to maintain the integrity of the cover system and to reduce the frequency of potential future settlement and cracks in the pavement surfaces.
- Costs assumes that a two foot Site-Wide engineered cover system will be constructed over the entire Site and an in-situ soil chemical oxidation treatment will be applied by injection into treatment boreholes installed in the Black Stained Sandy soil source area to treat volatile organic and SVOC contaminants.

- It is assumed that this chemical oxidation remedy would cost approximately the amount described in Table 1 at the time of implementation.
- At this time, final grading plans have been developed so the Site can be graded to enhance preferred drainage with minimal additional excavation, install the cover system and storm water detention system in a manner so that the entire Site will be covered with the cover system and will be maintained to reduce settlement or cracking of the pavement surface.

## 5.4 COMPARATIVE ANALYSIS

The following subsections provide a brief comparison of the alternatives relative to the same nine criteria used to evaluate the alternatives individually. As previously identified in this AAR, the alternatives have been compared based upon the following nine criteria:

1. Overall protection of human health and the environment
2. Compliance with Standards, Criteria, and Guidance (SCGs)
3. Long-term effectiveness and permanence
4. Reduction in toxicity, mobility, and volume
5. Short-term effectiveness
6. Implementability
7. Cost estimate
8. Land Use
9. Green Sustainable Remediation Principles

### 5.4.1 Protection of Human Health & the Environment

#### ***Alternative 1 Comparisons - Protection of Human Health & the Environment***

As previously discussed, Alternative 1 - No Action, combined with an Institutional Control (groundwater use prohibition) and engineering controls (Site fencing), was maintained for a baseline comparison of the alternatives. However, is not considered sufficiently protective of human health and environment. Therefore, Alternative 1 will not be selected as the preferred alternative for managing the contamination at the Site.

#### ***Alternative 2 Comparisons - Protection of Human Health & the Environment***

Complete removal and off-site disposal of all contaminated media described in Alternative 2 would provide the greatest overall protection for potential human health and environmental receptors.

#### ***Alternative 3 Comparisons - Protection of Human Health & the Environment***

Alternative 3 includes a Site-wide engineered cover system over historic fill soils with excavation and off- Site disposal of Black Stained Sandy Soils source area. Placing a Site-wide engineered cover system on the entire Site to prevent potential exposure of COCs with management of remaining contamination through an SMP that details ECs and ICs with an environmental easement will significantly reduce the potential exposure to Human Health and Environmental receptors.

Excavation and removal of the Black Stained Sandy Soil source area is also part of this alternative. This area contains elevated levels of SVOCs, mid-range diesel organic compounds, organic vapors,



and creosote odors. After removal of this distinct Black Stained Sandy Soil source area, the majority of the Site-wide historic fill contamination is left in-place. The potential for cross media migration of contaminants in the historic fill into the groundwater will be reduced by the cover system since the cover system will be designed to reduce the amount of infiltration of surface run off from entering the subsurface at the Site. The highest collective concentration of Site contaminants, including but not limited to elevated organic vapors and midrange diesel organics, which are contained in the Black Stained Sandy Soil source area, would be excavated and transported off-site for disposal. The excavated area would then be backfilled with the bio-cell soils/soil piles and to the extent required, with imported clean granular soils to bring the Site to grade under the cover system. These soils would be covered by the cover system. Overall, this alternative would be more protective of human health and the environment when compared to Alternatives 1, and would be similar in protectiveness to alternatives 4, and 5.

#### ***Alternative 4 Comparisons - Protection of Human Health & the Environment***

Alternative 4 includes **Site-wide engineered cover system over impacted soils with soil vapor extraction system for *In Situ* treatment of Black Stained Sandy Soils source area.**

A Site-wide engineered cover system would be placed on the entire Site as described for Alternative 3 and the contaminated historic fill would be left in place. This alternative also includes a vapor extraction system to use as an in-situ remediation technology to remove the contaminants that include: elevated organic vapors, SVOCs, and creosote odors from the Black Stained Sandy Soil source area at a rate faster than natural attenuation. This In-situ treatment technology will take longer to achieve results which have the potential to be less protective of human health and the environment than Alternative 3, and over a much longer period of time.

#### ***Alternative 5 Comparisons - Protection of Human Health & the Environment***

Alternative 5 includes a **Site-wide engineered cover system over Historic Fill soils with Chemical Oxidation for *In Situ* treatment of Black Stained Sandy Soils source area.**

A Site-wide engineered cover system would be placed on the entire Site as described for Alternatives 3 and 4 and contaminated historic fill would be left in place. This alternative includes in-situ chemical oxidation (ISCO) remediation technology to oxidize both the organic compounds and SVOCs contaminants in the Black Stained Sandy Soil source area at a rate that is more rapid than the soil vapor extraction system in Alternative 4. The Alternative 5 in-situ treatment technologies take longer to function to achieve a result which may be less protective of human health and the environment than removal, and over a much longer period of time.

### **5.4.2 Compliance with SCGs**

#### ***Alternative 1 Comparison – Non-Compliance with SCGs “No-Action” Alternative***

Alternative 1 does not meet the Track 2 or 4 SCGs since source removal of the most significant area of contamination at the Site is not addressed and human exposure can result from surface soils that would not be addressed. Therefore, implementation of Alternative 1 would not reduce the contamination and would not result in compliance with SCGs. This alternative would be completed with the lowest level of compliance with SCGs when compared to Alternatives 2, 3, 4, and 5.

***Alternative 2 Comparison - Compliance with Track 1 SCGs- Removal of All Contaminated Soils to Meet Track 1 Standards and Placement of Controlled Backfill with Restoration of Ground Surface.***

Alternative 2 would achieve a Track 1 remedial goal, which is the highest level of remediation, since essentially all of the contaminants would be removed from the Site down to a depth of approximately 80 feet in some locations during the active remediation phase. Alternative 2 would result in a permanent reduction of all contaminants of concern. Therefore, after completion of the remediation tasks described for this Alternative the Track 1 SCGs would be achieved in compliance with SCGs. Implementation of Alternative 2 would achieve the highest level of compliance with SCGs when compared to Alternatives 1, 3, 4, and 5.

***Alternative 3 Comparison - Compliance with Track 4 Restricted Residential SCGs – Removal of Black Stained Soil Source Area Hot Spot and Site-Wide Engineered Cover System***

Alternative 3 would use a combination of a Site-wide cover system with soil excavation in the Black Stained Soil source area (hot spot) located around TP-132 with the highest concentration of organic vapors and SVOC contamination at the Site, which would result in a reduction of both volume and concentrations of these contaminants in these Site soils and containment of the site-wide historic fill soils. In addition, this alternative includes passive remediation for the remainder of the Site through a Site-wide cover system that would result in reduced concentrations of organic contaminants and some SVOCs in Site soils over time. The engineered Site-Wide cover system would reduce the potential for cross media migration of contaminants in the historic fill soils from entering the groundwater by significantly reducing the infiltration of surface runoff water from entering the subsurface and thereby increasing the protection of groundwater at the Site. This Alternative would result in compliance with Track 4 restricted residential (RRSCGs), which are protective of public health and the environment. Implementation of Alternative 3 would provide a higher level of certainty regarding compliance of SCGs than Alternatives 1, 4, and 5.

***Alternative 4 Comparison - Compliance with Track 4 Restricted Residential SCGs - Site-Wide Engineered Cover System over Impacted Soils with Soil Vapor Extraction System for In Situ Treatment of Black Stained Sandy Soils Source Area***

Alternative 4 would use a combination of a Site-wide cover system with In Situ soil vapor extraction to actively remediate the Black Stained Sandy Soils source area, which would result in reduced concentrations of organic vapors, midrange diesel organic compounds and other SVOC contaminants in the Site soils. The entire Site would be covered with a Site-Wide cover system and undergo passive remediation that would also result in reduced concentrations of organic contaminants and some SVOCs in Site soils over time. Although this remedial alternative would be intended to result in compliance with SCGs the anticipated reduction would be less certain when compared to Alternatives 2 and 3 and in greater compliance compared to Alternative 1, and approximately equal to compliance of SCGs for Alternative 5. In the area of source removal, there would be no reduction in the levels of metals present at the Site under Alternative 4. Since, there will not be any reduction of metals, while Track 2 may be achieved for SVOC contaminants, this Track would not be achieved for metals. Therefore, this is a Track 4 remedy. While the engineered Site-Wide Cover System would reduce the potential for cross media migration of contaminants in the historic fill soils from entering the

groundwater by significantly reducing the infiltration of surface runoff water from entering the subsurface and thereby increasing the protection of groundwater at the Site.

***Alternative 5 Comparison - Compliance with Track 4 Restricted Residential SCGs Site-wide engineered cover system over Historic Fill soils with Chemical Oxidation for In Situ treatment of Black Stained Sandy Soils source area.***

Alternative 5 would use a combination of a Site-wide cover system with In-situ chemical oxidation treatment to actively remediate the Black Stained Sandy Soils source area, would result in reduced concentrations of organic vapors, midrange diesel organic compounds and other SVOC contaminants in the Site soils, which would result in reduced concentrations of organic and SVOC contaminants in the Site soils. The entire Site would be covered with a Site-Wide engineered cover system and undergo passive remediation that would also result in reduced concentrations of organic contaminants and some SVOCs in Site soils over time. Although this remedial alternative would be intended to result in compliance with Track 2 SCGs for organics and SVOCs, the anticipated contaminant reduction would be less certain when compared to Alternatives 2 and 3, and in greater compliance compared to Alternative 1, and approximately equal to compliance that would be achieved for SCGs from implementation of Alternative 4. This alternative would most likely result in reduced concentrations of contaminants including organic compounds and SVOCs. However, since there will not be any reduction of metals, while Track 2 may be achieved for organics and SVOC contaminants, this Track would not be achieved for metals. Therefore, this is a Track 4 remedy. The engineered cover system would reduce the potential for cross media migration of contaminants (metals and SVOCs) in the historic fill soils from entering the groundwater by significantly reducing the infiltration of surface runoff water from entering the subsurface and thereby increasing the protection of groundwater at the Site.

### **5.4.3 Long-Term Effectiveness and Permanence**

***Alternative 1 Comparison - Long-Term Effectiveness and Permanence***

Alternative 1 provides no active remedy for the contaminants at the Site, and therefore, provides no long-term effectiveness in reducing exposure of the Site contaminants to human Health and the environment, other than limiting access to the Site with fencing and a locked gate. Alternative 1 provides the lowest level of long-term effectiveness and permanence when compared to alternatives 2, 3, 4, and 5.

***Alternative 2 Comparison - Long-Term Effectiveness and Permanence***

Alternative 2 provides the most long-term effective and permanent remedy for the Site contamination because essentially all contaminated soil is disposed of off-site reducing potential exposure to humans and the environment after the remediation is complete. By removing all impacted historic fill soil and backfilling the entire site with clean imported soils, the impacts to groundwater quality would be significantly reduced, which would ultimately reduce the potential exposure to humans through contact with groundwater. Therefore, this alternative provides the greatest level of long-term effectiveness and permanence when compared to Alternatives 1, 3, 4, and 5.

***Alternative 3 Comparison- Long-Term Effectiveness and Permanence***

Alternative 3 will provide a permanent cover system to isolate the historic fill soils that are the source of the contamination at the Site. In addition, the Black Stained Sandy Soil source area of highest organic vapor and SVOC contamination at the Site will be excavated and transported off-site for disposal. Therefore, implementation of this combination of remedial technologies provides a permanent reduction in both volume and concentration of containments for Site Soils and also reduces impacts to groundwater. Therefore, Alternative 3 provides a low level potential exposure to human health and the environment by permanent isolation and reduction of Site contaminants in impacted soil and groundwater and the low potential soil vapor intrusion issues are substantially reduced with long term ECs and ICs. Alternative 3 provides a lower level of long-term effectiveness and permanence when compared to Alternative 2, since the majority of contaminants remain isolated on Site and only a limited area removed from the Site. However, Alternative 3 provides a greater level of long term effectiveness and permanence when compared to Alternatives 1, 4, and 5, since these alternatives would not be as certain to reduce the volume or concentrations of contaminants.

***Alternative 4 Comparison- Long-Term Effectiveness and Permanence***

Alternative 4 also provides a permanent cover system to isolate the historic fill soils that are the source of the contamination at the Site. Alternative 4 differs from Alternative 3 since an in-situ soil vapor extraction system is used to remove the organic vapors (organic chemical compounds) and a limited number of SVOCs contaminants from the highest impacted soil located in the Black Stained Sandy Soil source area in place as compared to the physical removal and off-Site disposal of these soils as part of Alternative 3. Implementation of this combination of remedial technologies provides a permanent reduction in concentration of containments for Site Soils and also reduces impacts to groundwater. However, the long-term effectiveness and permanence for Alternative 4 is less certain when compared to Alternatives 2 and 3 since residual concentrations of contaminants may permanently remain in the Black Stained Sandy Soil source area after the remediation is complete for Alternative 4 and are removed for off-Site disposal in Alternatives 2 and 3. It is not entirely known if the long-term effectiveness and permanence of Alternative 4 would be slightly more or less certain than Alternative 5. Anticipated residual concentrations left on Site may be higher for Alternative 4 due to inherent pockets of soils between the vapor extraction wells that may not be remediated by the vacuum of these wells at fixed locations in the source soils being remediated. On the other hand, uncertainty regarding direct contact of the chemical oxidation agents and the contaminated soils is at issue with Alternative 5. Long-term effectiveness and permanence of Alternative 4 would be higher when compared to Alternative 1.

***Alternative 5 Comparison- Long-Term Effectiveness and Permanence***

Alternative 5 also provides a permanent cover system to isolate the historic fill soils that are the source of the contamination at the Site. Alternative 5 is similar to Alternative 4, except that this alternative uses In situ chemical oxidation for in place treatment of the highest impacted soils located in the Black Stained Sandy Soil source area for remediation of organic compounds and SVOC contaminants. Implementation of this combination of remedial technologies provides a permanent reduction in concentration of containments for Site Soils and also reduces impacts to groundwater. However, the long-term effectiveness and permanence for Alternative 5 is less certain when compared to Alternatives 2 and 3 since residual concentrations of contaminants may permanently remain in the Black Stained Sandy Soil source area after the remediation is complete for Alternative 5



and are removed for off-Site disposal in Alternatives 2 and 3. It is not entirely known if the long-term effectiveness and permanence of Alternative 5 would be slightly more or less certain than Alternative 4. This is due to the chemical oxidation compound that has the ability to remediate a wider range of SVOC compounds that are not able to be remediated using the soil vapor extraction technology used in Alternative 4. In addition, the chemical oxidation slurry (liquid mixture) is injected at locations into the source area soils in boreholes (injection points) that can be moved in response to completion of an initial application that is followed by a second application to attempt to provide better coverage of the remediation when compared to the fixed soil vapor extraction wells in Alternative 4. However, it is also possible that Alternative 5 may have issues regarding direct contact between chemical oxidation agents and contaminants. Long-term effectiveness and permanence of Alternative 5 would be higher when compared to Alternative 1.

#### **5.4.4 Reduction in Toxicity, Mobility, and Volume**

##### ***Alternative 1 Comparisons- Reduction in Toxicity, Mobility, and Volume***

Alternative 1 provides no reduction in toxicity, mobility or volume of contaminants at the Site. The alternative would only include EC and IC that include fencing and a locking gate. There is no action for physical remediation for this alternative.

##### ***Alternative 2 Comparisons- Reduction in Toxicity, Mobility, and Volume***

Alternative 2 provides the greatest reduction in the toxicity, mobility, and volume of contaminants by removing all contaminants from the Site followed by backfilling the Site with imported clean soils. Therefore, alternative 2 provides the highest level for this comparison when compared to each of the other alternatives.

##### ***Alternative 3 Comparisons- Reduction in Toxicity, Mobility, and Volume***

Alternative 3 would reduce the toxicity, mobility, and volume of contaminants at the Site. The reduction of toxicity in the source area would result from the physical removal and off-Site disposal of the Black Stained Sandy Soil that is the area of greatest contamination for organic vapors and SVOCs. This area also contains some metals that are COC and would be remediated for this source area. In general, the metals were detected at lower concentrations in the Black Stained Sandy soil source area when compared the elevated concentrations of metals in historic fill soils that comprise the majority of the historic fill Site-wide. The volume of impacted soils would also be reduced since these soils would be removed and transported off-site. The mobility of contamination would also be reduced by the Site-wide engineered cover system that will reduce the potential for migration of dust. The engineered cover system over time would also reduce contaminants from entering (migrating) from the impacted soils into the groundwater. However, the majority of the contaminant's toxicity would remain unchanged and isolated under the engineered cover system.

Therefore, Alternative 3 would provide a greater degree of certainty regarding the reduction in toxicity, mobility, and volume of COCs when compared to Alternatives 1, 4 and 5 since the source area will be predominantly removed and disposed of off-site. Since, Alternative 1 provides no reduction of contaminants and Alternatives 4 and 5 provide a lower degree of certainty regarding the reduction of toxicity for organic compounds since they are treatment remedies as opposed to removal remedies, there is more limited reduction in the mobility, and volume of contaminants under these remedies than Alternative 3.



**Alternative 4 Comparisons- Reduction in Toxicity, Mobility, and Volume**

Alternative 4 would reduce the toxicity and mobility of contaminants at the Site (volatile fractions of SVOCs/mid-range diesel organics and VOCs). The reduction of toxicity of impacted soil would result from the removal of volatile organic compounds and limited SVOCs from the Black Stained Sandy Soil source area that is the area of greatest contamination for organic vapors and SVOCs. This area also contains some metals that are COC and would not be remediated using this alternative. The overall volume of impacted soils would generally not be reduced since these soils would be remediated in place by the in situ vapor extraction system in contrast to physical soil removal. The mobility of contamination would also be reduced by the Site-wide engineered cover system that will reduce the potential for migration of dust as part of this alternative. The engineered cover system over time would also reduce contaminants from migrating from the impacted soils into the groundwater. However, the majority of the Site-wide contaminants toxicity would remain unchanged and isolated under the engineered cover system and the level of toxicity of containments in the black Stained Sandy soil source area would be greater than Alternative 3 due to residual concentrations and isolated pockets of soil that may not be remediated by this soil vapor extraction system.

Therefore, Alternative 4 would provide a greater degree of reduction in toxicity and mobility, and volume of COCs when compared to Alternative 1 and less certainty regarding the reduction of these elements when compared to Alternatives 2, 3 and 5.

**Alternative 5 Comparisons- Reduction in Toxicity, Mobility, and Volume**

Alternative 5 would reduce the toxicity and mobility of the Site's volatile fractions of SVOCs/mid-range diesel organics and VOCs contaminants. The reduction of toxicity of impacted soil would result from the oxidation of volatile organic compounds and SVOCs from the Black Stained Sandy Soil source area that is the area of greatest contamination for organic vapors and SVOCs. This area also contains some metals that are COCs and the toxicity of metals would not be reduced using this alternative. The overall volume of impacted soils would generally not be reduced since these soils would be remediated in place by the In Situ chemical oxidation in contrast to physical soil removal. The mobility of contamination would also be reduced by the Site-wide engineered cover system that will reduce the potential for migration of dust as part of this alternative. The engineered cover system over time would also reduce contaminants from migrating from the impacted soils into the groundwater. However, the majority of the Site-wide contaminant toxicity would remain unchanged and isolated under the engineered cover system and the level of toxicity of containments in the black Stained Sandy soil source area would be greater than Alternatives 2 and 3 due to residual concentrations in soil in the source area that may not be remediated by chemical oxidation.

This alternative would provide a greater level of reduction of toxicity when compared to Alternative 4. Since, the chemical oxidation treatment allows for a more complete remediation of the organic compounds and SVOCs in the Black Stained Sandy Soil source area when compared to the soil vapor extraction technology for Alternative 4.

Therefore, Alternative 5 would provide a greater degree of certainty regarding the reduction in toxicity and mobility of COCs when compared to Alternatives 1 and 4 and less of certainty regarding reduction of these elements when compared to Alternatives 2 and 3.

#### 5.4.5 Short-Term Effectiveness

##### ***Alternative 1 Comparisons- Short-Term Effectiveness***

Alternative 1 provides no active remedy for the contaminants at the Site, and therefore, provides no short-term effectiveness in reducing exposure of the Site contaminants to human Health and the environment, other than limiting access to the Site with fencing and a locked gate. Alternative 1 provides the lowest level of short-term effectiveness when compared to Alternatives 2, 3, 4, and 5.

##### ***Alternative 2 Comparisons- Short-Term Effectiveness***

The timeframe required to complete this alternative and to achieve the SCGs would require approximately 2 years and is relatively a short period of time when compare to Alternative 4 that would require approximately 10 years to complete the remediation. Therefore, during a relatively short period of time the highest level of cleanup would be reached. The high level of short-term effectiveness would be realized at the end of active remediation. Since, essentially all of the containments would be removed from the Site and replaced with clean backfilled soils imported to the Site. Short-term effectiveness of Alternative 2 is considered high when compared to Alternatives 1, 4, and 5 and slightly higher than Alternative 3. Alternative 2 would result in the short term effectiveness in terms of protection of human health (worker exposure) and the environment. In addition to worker safety around deep excavations, this task has the potential to generate the greatest amount of fugitive dust emissions over the longest period of time, require the greatest amount of storm water management/treatment, and would cause the greatest increase in the amount of truck traffic within local area of the City. This Alternative would also disrupt the operations at the Volunteers of America's Daycare facility. Alternative 2 is considered to pose the greatest potential safety threat to workers during the remedial actions due to the site wide magnitude of the excavation area (approximately 3 acres and approximately 45 to 80 feet deep) and large excavation equipment associated with Alternative 2, and the hazards of working with this equipment and large soil processing equipment.

##### ***Alternative 3 Comparisons- Short-Term Effectiveness***

The timeframe required to complete this alternative and to achieve the SCGs would require approximately 6 months to complete the active remediation and approximately 5 years to demonstrate that the SCGs have reached the RAOs. Therefore, several years will be required to complete the remediation and demonstrate the short-term effectiveness when compared to Alternative 2 that may be competed in an approximate 2 year timeframe with a high level of short- term effectiveness realized at the end of active remediation. This is relatively a short period of time when compare to Alternative 4 that would require several years to complete the remediation.

##### ***Alternative 4 Comparisons- Short-Term Effectiveness***

The timeframe required to complete this alternative and to achieve the SCGs would require approximately 10 years to complete active remediation and approximately 5 years to demonstrate that the SCGs have reached. Therefore, several years will be required to complete the remediation and demonstrate the short-term effectiveness when compared to Alternatives 2 and 3 that would be competed in shorter timeframes and with greater effectiveness with respect to reduction of COC. Alternative 4 would likely have a lower short-term effectiveness when compared to Alternative 5 and would have higher short-term effectiveness than Alternative 1.

The soil vapor extraction system would need to be operated over an estimated period of approximately 10 years, and will reduce the impacts to soils by removing a majority of SVOC contaminants in this limited area of the Site. The placement of an engineered cover system over the remainder of the historic fill soils at the Site in both alternatives 3 and 4 will reduce the potential short term exposure of the contaminants to humans and the environment after the remediation is complete, including direct contact with impacted media or fugitive dust but does not result in a rapid permanent remedy.

### ***Alternative 5 Comparisons- Short-Term Effectiveness***

The timeframe required to complete this alternative and to achieve the SCGs would require approximately 6 months to complete active remediation and approximately 5 years to demonstrate that the SCGs have reached and realize the reduction of COC. Therefore, several years will be required to complete the remediation and demonstrate the short-term effectiveness that would be less when compared to alternatives 2 and 3 would be slightly greater when compared to alternative 4 and greater than alternative 1 effectiveness. Alternative 5 would likely have a lower short-term effectiveness when compared to Alternative 3 and would have higher short-term effectiveness than Alternatives 1 and 4.

### **5.4.6 Implementability**

#### ***Alternative 1 Comparison - Implementability***

Alternative 1 is the quickest to implement and also the simplest alternative to implement. However, groundwater monitoring would have to continue for at least 30 years. Since, this alternative includes no active remediation with only ECs and ICs that would require additional fencing and a secure access gate to limit access to the Site to protect human health, even if the Site was not redeveloped.

#### ***Alternative 2 Comparison- Implementability***

Alternative 2 is technically implementable and the most complicated over the longest period of time due to the requirements for health and safety plan preparation and project management to complete an extensive and deep excavation which is similar to an open mining operation during a 2-year period of time. This alternative could not be integrated with VOA's future re-development and would have to be completed prior to any future VOA re-development construction work, which would end the current plans for short term site redevelopment. The risks associated with worker health and safety, Site security, elevated noise level, increased truck and construction equipment traffic, and potential off-Site migration of dust contaminants is also the highest for this alternative during the active remediation when compared to the other alternatives. In addition, this alternative would also require a groundwater dewatering system, during this long term Site excavation project, to complete an excavation of this size.

Implementing a dewatering system to control the water table so that soils below the water table are able to be excavated would result in very large amounts of water that would need to be stored, treated or transported off-site for disposal at a waste water treatment facility. Significant engineering deep excavation plans and Site controls would be required due to the depth of this excavation and also to address fugitive dust, deep excavation hazards, shoring, storm water runoff, and removal and

importing large quantities of soil would result in significantly increased truck traffic through local, densely urban communities. Therefore, this alternative would be the most difficult to implement due to the overall magnitude of the size of the proposed excavation requirements to physically complete the work. Alternative 2 is the least implementable over the longest period of time since it is equivalent to an open mining operation.

### ***Alternative 3 Comparison- Implementability***

Alternative 3, is technically implementable because the hot spot removal effort consists of a lower magnitude limited excavation (35 ft. X 35 ft. X 20 feet deep), far less significantly than Alternative 2, and thus the impacts can be mitigated more easily. A Site-wide cover system along with the existing pavement parking lots / roadways is implementable since it is essentially the construction of a parking lot. Implementation of Alternative 3 will result in the short term need to control dust emissions and control truck traffic at the Site and in the neighborhood, however, these impacts will be controlled through implementation of the HASP and CAMP during the remediation.

The short term potential risks associated with worker health and safety, Site security, elevated noise level, increased truck and construction equipment traffic, and potential off-Site migration of dust contaminants is the higher for this alternative during the active remediation when compared to the other alternatives except for Alternative 2.

### ***Alternative 4 Comparison- Implementability***

Alternative 4 is technically implementable with levels of potential risks associated with worker health and safety, Site security, elevated noise level, increased truck and construction equipment traffic, and potential off-Site migration of dust contaminants that are lower for this alternative during the active remediation when compared to Alternatives 2 and 3. Alternative 4 is also easier to implement when compared to Alternative 2 and 3, since large excavations are not required for this Alternative and installation of the soil vapor extraction system wells and trenches for In Situ remediation of the Black Stained Sandy soil source area is less difficult to implement when compared to Alternatives 2 and 3 due to the deep excavation required to remove the soil source area for Alternative 3 and the large and deep Site-wide excavation required to completed Alternative 2. Alternative 4 is more difficult to implement due to trenches and vapor well installations when compared to Alternative 5.

### ***Alternative 5 Comparison - Implementability***

Alternative 5 would be easier to implement than Alternatives 2, 3 and 4. Alternative 5 includes installation of soil boreholes in the Black Stained Sandy Soil source area for In situ treatment and excavation for trenches required in Alternative 4 are not required. Therefore, Alternative 5 does not include any excavations other than soil boreholes and limited grading to install the Site-wide engineered cover system. The potential risks during active remediation associated with worker exposure, off-Site migration of dust, and health and safety concerns is less when compared to Alternatives 2, 3, and 4.

#### 5.4.7 Estimated Cost

A comparison of the estimated cost to complete each of the alternatives is presented in the following text. The preliminary cost estimates for each alternative are list in Table 1.

##### ***Alternative 1 Comparison - Estimated Cost***

Implementation of Alternative 1 would result in the lowest cost when compare to the other alternatives. However, this alternative only includes ECs and ICs without active remediation. Therefore, without active remediation, the Track 4 remedial goal for protection of Human Health and the Environment would not be achieved after implementation of this alternative. The estimated cost includes additional fencing and a locking gate to limit Site assess with signage, a Site groundwater restriction, and groundwater monitoring for 30 years. The estimate capital cost for alternative 1 is \$40,000 with annual cost of \$14,637. The total present worth is \$265,007. In addition, the Site could not be developed for commercial use, and this remedy would substantially reduce the value of this three acre site and as a result would be very costly to VOA through the elimination of this property for their intended re-development.

##### ***Alternative 2 Comparison - Estimated Cost***

The estimated cost for Alternative 2, which includes a Site-wide excavation area with depths to approximately 80 feet would be required to remove essentially all of the impacted soils is prohibitively cost excessive. The estimated cost also includes transportation and off-Site disposal of impacted soils with clean imported soil for excavation backfill. The estimated capital cost for this alternative is \$24,238,000 and total present worth is the same. This alternative is the most expensive by greater than an order of magnitude over Alternatives 3, 4 or 5. This alternative is the least cost effective when compared to the other alternatives.

##### ***Alternative 3 Comparison - Estimated Cost***

The estimated capital cost for Alternative 3, which includes a Site-wide engineered cover system, limited excavation/off-site disposal of the Black Stained Sandy soil source area and installation of a storm water detention system with ECs and ICs is \$1,244,672 and \$4,718 annual cost. Therefore, total present worth is \$1,317,191. This alternative also includes backfilling the source area soil excavation with on-Site soils or imported soils, if required. The cost estimate has been calculated for the active remediation for source area soil excavation, installation of the storm water detention system will be backfilled and then the Site-wide engineered cover system will be completed. This sequencing and integration of construction work will reduce the risk of potential compromised of the engineered cover system. Alternative 3 is more expensive to implement when compared to 7alternatives 4 and 5. However, the estimated cost for Alternatives 3, 4, and 5 are in the same relative range; between 2.4 million and 2.8 million.

##### ***Alternative 4 Comparison - Estimated Cost***

The estimated capital cost for Alternative 4, which includes a Site-wide engineered cover system, storm water detention system and soil vapor extraction for treatment of the Black Stained Sandy soil source area with ECs and ICs, is \$1,090,319 with annual cost of \$9,168. Therefore, the total present worth is \$1,231,246. This Alternative includes construction of a Site-wide engineered cover system,



as described above for Alternative 3, combined with a soil vapor extraction system for In Situ treatment of the Black Stained Sandy soil source area. The estimated cost to implement Alternative 4 is less than Alternative 3 and slightly more than Alternative 5.

#### ***Alternative 5 Comparison - Estimated Cost***

The estimated capital cost for Alternative 5 that include a Site-wide engineered cover system, storm water detention system and chemical oxidation technology for treatment of the Black Stained Sandy soil source area with EC and IC is \$1,101,782 with annual cost of \$4,718. Therefore, the total present worth is \$1,174,301. This Alternative also includes construction of a Site-wide engineered cover system, as described above for Alternative 3, combined with chemical oxidation technology for In Situ treatment of the Black Stained Sandy soil source area. The estimated cost to implement Alternative 5 is less than Alternatives 4 and 3. Alternative 2 is the most expensive to implement and Alternative 1 is the lowest cost to implement.

#### **5.4.8 Land Use**

Unlike the Superfund Program, the Brownfield Program encourages land use to put brownfield sites back on the tax rolls. A comparison of the land use criteria for each of the alternatives is presented in the following text.

#### ***Alternative 1 Comparison - Land Use***

Since Alternative 1 may not permit any reuse of the Site due to surface soil contamination, this Alternative is inconsistent with the land use criteria.

#### ***Alternative 2 Comparison - Land Use***

This alternative would prohibit any land use to occur for likely more than two years.

#### ***Alternative 3 Comparison - Land Use***

This alternative would allow for restricted residential or commercial or even industrial development to proceed in the future provided the future developer complies with the SMP and restores the engineered Site-wide cover system post construction and installs a soil vapor mitigation system below the future structure. However, unlike Alternatives 4 and 5, this Alternative would expeditiously address the only volatile organic vapor source area associated with potential vapor intrusion issues in future Site buildings by removal of the Black Stained Sandy Soil source area (hot spot) from the Site.

#### ***Alternative 4 Comparison - Land Use***

This alternative would allow for future restricted residential development, but the one source area of vapors on the Site would not be eliminated for a number of years (approximately 10 years).

#### ***Alternative 5 Comparisons - Land Use***

This alternative would allow for future restricted residential development, but the one source area of vapors on the Site would not be eliminated for a number of years (approximately 10 years).

At this time, all cost estimates are considered approximate and are subject to change.

#### 5.4.9 Green and Sustainable Remediation Principles

Planning and comparisons for Green and sustainable remediation principle comparisons were evaluated for Alternatives 1 through 5. Significant benefit to the environment with application of green remediation concepts can be realized at the remedy selection phase. Several factors are considered when selecting a remedy and sustainability/green remediation is an aspect of one or more of the existing criteria. Therefore, green and sustainable concepts are used to support selection of the best remedy for a site. The consideration of sustainability in remedy selection is consistent with existing statutes, regulations, and guidance.

Green remediation concepts and techniques will be considered during all stages of the proposed remediation program, to long-term site management obligations with the goal of improving the sustainability of the cleanup. The major green remediation concepts and green remediation techniques below will be considered and used to the extent feasible by remedial parties and NYSDEC staff.

##### Green Remediation Concepts

- Considering the environmental impacts of treatment technologies and remedy stewardship over the long term when choosing a site remedy;
- Increasing energy efficiency and minimizing use of non-renewable energy;
- Conserving and efficiently managing resources and materials;
- Reducing waste, increasing recycling and increasing reuse of materials which would otherwise be considered a waste;
- Fostering green and healthy communities and working landscapes which balance ecological, economic and social goals; and
- Integrating the remedy with the end use where possible and encouraging green and sustainable re-development.

##### Green Remediation Techniques

VOA has evaluated and incorporated green remediation concepts as part of the AAR remedies evaluation and will attempt to implement the green remediation techniques below that may apply to the planned remediation.

- Reduce vehicle idling. All construction vehicles and equipment will be shut off when not in use for more than 5 minutes, consistent with 6 NYCRR Part 217 Motor Vehicle Emissions, Subpart 217-3 Idling Prohibition for Heavy Duty Vehicles.
- Design cover systems, to the extent possible, to be usable for alternate uses such as passive recreation, require minimal maintenance or be integrated with the next use of the Site.
- Beneficially reuse materials that would otherwise be considered a waste (e.g. crushed clean concrete as sub-base or backfill).
- Use of Ultra Low Sulfur Diesel (ULSD).
- Prevent long-term erosion, surface runoff, and off-site water quality impacts

- Encourage development and evaluation of low energy alternatives such as enhanced bioremediation, phytoremediation, permeable reactive barriers (PRBs), source removal with monitored natural attenuation (MNA), enhanced attenuation of chlorinated organics (EACO), engineered wetlands, and remedies which can be driven to MNA or monitoring only (e.g., remedies which will not need external power indefinitely)
- Address sources more aggressively to reduce long-term operation and maintenance of treatment or containment systems
- Reuse and Recycle construction and demolition (C&D) debris and other materials Maximize beneficial use of materials that would otherwise be considered a waste
- Integrate remedial design with contemplated reuse of site
- Design cover systems to be usable

A comparison of the land use criteria for each of the alternatives is presented in the following text.

#### ***Alternative 1 Comparison - Green and Sustainable Remediation***

Since Alternative 1 may not permit any reuse or enhancement of ecological habitat, social goals, and economy due to continued vacant use and surface soil contamination. Therefore, this alternative ranks last for green and sustainable remediation as compared to the others.

#### ***Alternative 2 Comparison - Green and Sustainable Remediation***

This alternative would use the most fuel energy in the excavation equipment and during truck transportation to remove all soils that are impacted on the site and import clean soils for backfill. Emissions to the air from the same construction and transportation equipment would also results in the highest carbon foot print for this remedy. However, this completed remedy would allow for Site reuse, and enhancement of ecological habitat, social goals, and local economy. This alternative ranks below Alternatives 3, 4, and 5 as compared for green and sustainable remediation.

#### ***Alternative 3 Comparison - Green and Sustainable Remediation***

This alternative would allow a reduction of waste by reuse of materials from the on-Site soil piles and bio-cells which would otherwise be considered a waste. The result of the remedy will allow for future redevelopment that can foster a working landscape, which will help to balance ecological, economic and social goals in this urban neighborhood. Therefore, positioning this Site for future redevelopment can providing a future green and sustainable re-development. This Alternative 3 is the most green and sustainable remediation as compared to the others.

#### ***Alternative 4 Comparisons - Green and Sustainable Remediation***

This alternative would require the greatest use of electric power consumption and O&M during the long term operation of the soil vapor extraction system during an approximate 10 year duration. Therefore, this Alternative 4 ranks below Alternatives 3 and 5 and above Alternatives 1 and 2 as compared for green and sustainable remediation.

#### ***Alternative 5 Comparisons- Green and Sustainable Remediation***

This alternative would result in a green and sustainable remediation that is ranked above Alternatives 1, 2, and 4. However, the in-situ chemical oxidation remediation portion of the remediation in Alternative

5 is inherently less sustainable and protective of human health over the long term when compared to the soil removal and off-site disposal included in Alternative 3. Therefore, this Alternative ranks below Alternatives 3.

Preliminary cost estimates to implement each Alternative are shown on Table 1- Estimated Total Present Worth. A summary of the ranking for comparison criteria is provided on Table 2 – Ranking of Analysis for Alternatives.

## **6.0 RECOMMENDATIONS**

### **6.1 ALTERNATIVE RECOMMENDATION**

Bergmann and VOA have evaluated the remedial alternatives in this AAR, the implementation of these technologies, and the resources required. Based on the results of the analysis, Alternative 3 is considered the most technically feasible and cost effective alternative, which achieves protection of human health and the environment with ease of long-term maintenance. Alternative 3 includes: Site-wide cover system over historic fill soils with excavation and off-Site disposal of Black Stained Sandy Soils source area, installation of a storm water detention system with long term ECs / ICs documented in a Site Management Plan and recorded in an environmental easement.

This proposed remedial program will reduce potential short term and long-term exposures to the Site contaminants by removing the Black Stained Sandy Soil source area from the Site and constructing a Site-wide engineered cover system that isolates COCs from potential exposure pathways. The combination of the Site-wide engineered cover system and removal of the source soils also reduces the volume and toxicity of the most contaminated soils and coupled with ECs and ICs provides a high degree of reduction of both potential migration and reduction of contaminants.

While contaminants will remain at the Site, the remedial objectives will be met to the extent practicable in a cost effective manner through the implementation of Alternative 3 and this alternative will be fully protective of human health and the environment.

Alternative 3 will also provide an effective long-term and permanent remedy for the Site by a reduction of volume of contaminants. The proposed excavation and off-site disposal will reduce the amount of contaminants at the Site that could result in potential future soil vapor intrusion concerns from the Black Stained Sandy Soil source area. The engineered cover system will limit potential human exposure to the contaminants and reduce impacts to the groundwater by reducing surface water infiltration at the Site. Although complete removal of all contaminated media to Track 1 standards under the Alternative 2 scenario is the most effective in the comparative analysis, the extensive construction effort, potential contaminant exposure for workers, impact on VOA operations, and excessive cost associated with Alternative 2 resulted in the elimination of this alternative.

Under Alternative 3, excavation activities will extend to approximately 20 ft. to remove the accessible portion of the contaminated Black Stained Sandy Soil source area and to construct a Site-wide engineered cover system above the historic fill soils throughout the entire Site. While, the remedy cannot eliminate all the historic fill material that has a potential for contributing to groundwater concentrations that exceed the groundwater standards. The cover system remedy will prevent further infiltration of surface water run-off into the groundwater that may increase the potential for groundwater contamination. The cover thickness will meet or exceed the NYSDEC DER-10 and BCP

cover system requirements. This Track 4 remedy, including ECs and ICs, will be protective of groundwater by reducing further potential contribution of contaminants into the groundwater.

The use of ECs and ICs to protect human health and the environment against the residual contaminants is also required for this Alternative. ICs would include implementation of an environmental easement to restrict land use to restricted residential use, prohibit the use of groundwater beneath the Site, and require the development and implementation of a SMP would include a soil management plan to be implemented during any future intrusive (excavation) activities below the demarcation marker. The primary EC would be the engineered cover system. Additional controls during Site remediation that would be recommended include: (1) dust control measures as detailed in the CAMP, (2) limiting access and construction hours, and (3) installing fencing and signs around the Site to deter trespassers from the Site.

Since contaminants will remain at the Site, it will also be necessary to institute a groundwater monitoring program to monitor the Site for a period of 5 years after the active remedial activities are complete. If there are no significant increases to current conditions after this monitoring period, then an evaluation will be undertaken to determine if the groundwater monitoring program can be discontinued. Existing wells will be used to perform monitoring unless wells are destroyed in redevelopment. The need to install new wells will be evaluated during remedy design phase for this project. The proposed remedial Alternative 3 is consistent with the proposed end use of the Site, which includes development of a ground floor commercial building and implementation of a site-wide cover system. Alternative 3 will be fully protective of human health and the environment.

Therefore, Alternative 3 summary of proposed remedial action will consist of:

- Implementation of a Citizen Participation Plan.
- Performance of a Community Air Monitoring Program for particulates and volatile organic carbon compounds / odors.
- Achievement of a Track 4 restricted residential remedy through implementation of a Site Wide Engineered Cover System and limited soil removal excavation with long term Engineering and Institutional Controls required pursuant to an SMP and EE.
- Collection and analysis of confirmatory end-point samples in the limited soil removal area to determine the performance of the remedy with respect to attainment of applicable restricted residential SCOs levels of remediation.
- Import of materials to be used for backfill and cover system in compliance with the Remedial Action Work Plan (RAWP), for remediation requirements and in accordance with NYSDEC DER-10 guidance. Potential re-use of Site soils as backfill in accordance with NYSDEC DER-10 guidance.
- Excavation and removal of Black Stained Sandy Soils with disposal at permitted facilities in accordance with applicable laws and regulations for handling, transport, and disposal. Sampling and analysis of excavated media as required by disposal facilities and NYSDEC. Appropriate segregation of excavated soils and materials on-Site.



- Screening of excavated soil/fill during intrusive work for indications of contamination by visual means, odor, and monitoring with a PID.
- Installation of a storm water detention system for storm-water pollution prevention measures in compliance with applicable laws and regulations.
- Performance of all activities required for the remedial action, including permitting requirements and pretreatment requirements, in compliance with applicable laws and regulations.
- Submission of a FER that describes the remedial activities, certifies that the remedial requirements have been achieved, includes a SMP, defines the Site boundaries, and describes Engineering and Institutional Controls to be implemented at the Site, and lists any changes from this RAWP.
- Submission of an approved Site Management Plan (SMP) in the FER for long-term management of residual contamination, including plans for operation, maintenance, monitoring, sampling, inspection and certification of Engineering and Institutional Controls and reporting at a specified frequency.
- Recording of an Environmental Easement (EE) that includes a listing of Engineering Controls and a requirement that management of these controls must be in compliance with an approved SMP; and Institutional Controls including prohibition of the following: (1) use of groundwater without treatment rendering it safe for the intended use; (2) disturbance of residual contaminated material unless it is conducted in accordance with the SMP; and (3) higher level of land usage without NYSDEC and NYSDOH approval.

## **7.0 REMEDIAL ACTION WORK PLAN – Overview**

This Remedial Action Work Plan (RAWP) presents the recommended actions to be implemented for the remediation elements presented in the selected Alternative #3 in the AAR. The development of this RAWP is in accordance with the Brownfield Cleanup Program Guide dated May 2004 and NYSDEC DER-10 dated, May 2010. The following sub-sections present the methods and procedures for implementation of the RAWP.

### **7.1 Site Location and Current Usage**

The project Site includes the eastern portion of Parcel A from the centerline of Haidt Place eastward and Parcel B located at back lot 214 Lake Avenue (18 Ambrose Street), Rochester, New York (Site). The Site is located on Tax Map Nos. 105.60-02-59.3 and 105.60-02-1.2 (214 Lake Avenue) and is located in a mixed commercial and residential area of the City of Rochester. The Site is located east of the centerline of Haidt Place and VOA's Office Building, Thrift Store and Day Care Center (VOA's Human Services Complex), which is a fully remediated and redeveloped former Brownfield site that was cleaned up under the NYSDEC Spills program. The Site is located at 18 Ambrose Street, west of the former Raeco Oil Superfund Site, and south of a contractor's equipment storage yard and building and a Monroe County right-of-way to the Pure Waters Tunnel Structure 41. The size of this Site, as defined in the Brownfield Cleanup Agreement (BCA) is approximately 3 (2.997) acres. The Site is comprised of portions of two tax parcels of land, which are referred to as the eastern portion of Parcel A and all of Parcel B. The majority of the Site is a largely undeveloped parking lot area and roadway.

On the east side of the Site, soil berms and former bio-cells, now with vegetation cover, is present to block the view of the Raeco Oil Superfund Site. The Site is currently a vacant urban field with parking lot and roadway. The Site location and surrounding vicinity are shown on Figure 1 - Site Vicinity Map. The approximate limits of the Site area are shown on Figure 12 - Site Plan with Hot Spot Excavation Area.

## 7.2 Pre-Remediation Conditions - Existing

The Site encompasses approximately 3 acres of a larger, former commercial property that is located at 214 Lake Avenue in the City of Rochester. As shown by Figure 2, the Site is predominantly a vacant urban brush covered field with shrubs and some trees and contains a paved access driveway and parking lot. Three former bio-cell soil stockpiles remain on-Site from a completed NYSDEC remediation project during the construction of the VOA Human Services Complex in 1998. Large soil berms (soil piles) remain along the eastern Site property line from the construction of the VOA Human Services complex building. The soil that constitutes the bio-cells has been remediated and can be reused on-Site for re-grading under the cover system as previously confirmed from confirmatory samples provided to NYSDEC. There are no buildings or structures on the Site. The western side of the Site is improved with parking areas and portions of roadway. Generally, the Site drains from west to east, and ponding is generally absent from the Site. RI investigations indicated that the Site contains contaminated historic fill soils at the ground surface due to materials landfilled and years of coal storage. The depths of historic fill soils ranges from 20 feet to approximately 80 feet below grade.

The Site is a vacant lot with exposed soil. Under current Site conditions human exposure is unlikely as the Site is vacant and access is limited by a fence along three sides. Groundwater is contaminated and the human exposure pathway is absent at the Site due to the depth of groundwater ranging from 15 to 20 feet below ground surface and since the Site is served by the public water supply (groundwater is not used at the Site). There is an existing potential exposure pathway from soil gas to enter into future on-Site buildings as a result of potential vapor encroachment conditions at the Site from the Black sandy soil area which contains VOCs. The proposed remedy will provide a cover barrier over the historic fill with removal of the majority of the Black Sandy Soil area (source area). The human exposure pathway that may remain is a potential for vapor intrusion from residual (remaining) source area soils with VOCs into the future Site building.

Potential Human receptors would be to on-Site commercial workers, and building occupants, who are expected to be senior adults. The primary route of exposure to VOCs would be inhalation. Based upon this analysis, currently, there are two potential Human exposure pathways: 1) from soil gas to enter structures and the future Site building as a result of foundation system elements such as slab/wall openings or cracks; and, 2) direct exposure to on-Site contaminated soils and dust from on-Site historic fill soils if left uncovered. The on-Site potential sensitive receptors include visitors, construction workers, pedestrians, trespassers, adult building occupants and commercial workers. The primary route of exposure would be inhalation and dermal contact on-Site. During remedial construction the potential on-Site and off-site exposures from contaminated dust, vapors and odors will be addressed through dust control methods and vapor / odor controls through the implementation of the Community Air Monitoring Program (CAMP) and a construction health and safety plan (CHASP). Implementation of these methods allow for action levels and plans to mitigate and prevent such exposures from occurring.

### **7.3 Proposed (Post-Remedial) Conditions - Future**

Once remediation and redevelopment activities begin, there will be a potential exposure pathway from contaminated surface and subsurface soil/fill to construction workers as a result of future subsurface on-Site construction/excavation activities below the demarcation barrier of the cover system. On-site construction workers potentially could ingest, inhale or have dermal contact with exposed impacted fill or soils. Similarly, off-site receptors could be exposed to dust from on-Site activities although the cover system will likely remain in place and mitigate any significant exposures. During subsurface construction below the demarcation barrier, on-Site and off-site exposures to contaminated dust from the Site will also be addressed through dust control and vapor / odor control methods detailed in the Site Management Plan (SMP). Implementation of plans, methods and procedures in the SMP will be required by VOA and all future owners and operators of the Site through implementation of the SMP and the Environmental Easement (EE) that runs with the land.

Once the remedial actions (See Figure 13 – Site wide Engineered Cover with Grading / Utilities) are completed, to the extent the cover system and future buildings require sub-slab depressurization systems in place and operated / maintained, potential on-Site or off-Site exposure pathways to adult residents, community residents, and construction workers will be eliminated. The on-Site potential vapor intrusion condition and exposures from soil vapors from Site sources will be eliminated by implementation of the vapor barrier and operation of active subsurface depressurization system (SSDS) below future on-Site buildings to be documented in the SMP. Direct exposure to impacted historic fill soils and dust that might impact on-Site or off-Site receptors will be prevented by the construction of the Site wide engineered cover system (cover system). Long term assurance of these protections will be achieved by Site inspections and annual certifications of the engineering controls and continued implementation of conformance with the institutional controls required by the SMP and EE in accordance with the NYSDEC approved Site Management Plan.

### **7.4 Summary of Proposed Site Availability for Redevelopment**

The remedial action contemplated under this RAWP is intended to position the Site for future redevelopment. Storm water drainage will be addressed through design and construction of appropriate facilities designed to handle a 100-year storm event. The proposed storm water drainage system will include storm water sewer drainage, which is designed to receive overflow during large storm events. The storm water drainage will be managed by the storm water detention system shown on Figure 13 with details on Figure 14 – Remediation construction Specifications & Details.

### **7.5 Description of Surrounding Property**

The area surrounding the subject property consists of a mix of residential and commercial properties. Each of the adjacent properties is described in detail in the table provided below:

Direction	Property Description
<b>North –</b> Adjacent properties	Contractor's equipment storage yard and Steel building and a Monroe County right-of-way to the Pure Waters Tunnel Structure 41.
<b>South –</b> Adjacent properties	Ambrose Street and VJ Stanley Plumbing Warehouse Building
<b>East –</b> Adjacent properties	City of Rochester Right of Way, Raeco Oil Superfund Site, Genesee River Gorge
<b>West –</b> Adjacent properties	VOA's Human Services Complex, VOA's Administration Office Building, Thrift Store, Day Care Center, and Lake Avenue

## 7.6 Summary of the Remedy

The proposed remedial action detailed for Alternative #3 in the AAR achieves protection of public health and the environment for the intended restricted residential use of the property. The proposed remedial action achieves the remedial action objectives established for restricted residential use and addresses applicable standards, criterion, and guidance; is effective in both the short-term and long-term effectiveness and reduces mobility, toxicity and volume of contaminants; is cost effective and implementable; and uses standards methods that are well established in the environmental remediation industry.

The proposed remedial action will consist of:

1. Implementation of a Citizen Participation Plan.
2. Performance of a Community Air Monitoring Program for particulates and volatile organic carbon compounds / odors.
3. Achievement of a Track 4 restrictive residential remedy through implementation of a Site Wide Engineered Cover System, storm water detention system, limited soil removal excavation with long term Engineering and Institutional Controls required pursuant to an SMP and EE.
4. Collection and analysis of confirmatory end-point samples in the limited soil removal area to determine the performance of the remedy with respect to attainment of applicable restricted residential levels of remediation.
5. Requirements for a vapor barrier system beneath future site buildings.
6. Requirements for Installation and operation of a vapor mitigation system as an active sub-slab depressurization system (SSDS) beneath future Site building.
7. Import of materials to be used for backfill and cover system in compliance with this plan, for remediation requirements and in accordance with NYSDEC DER-10 guidance. An attempt to use on-site soils as backfill will be made as a green remediation technique.
8. Transportation and off-site disposal of soil/fill material from the proposed impacted soil (Black Stained Sandy Soils) removal excavation at permitted facilities in accordance with applicable laws and regulations for handling, transport, and disposal. Sampling and analysis of excavated

media as required by disposal facilities and NYSDEC. Appropriate segregation of excavated soils and materials on-Site.

9. Screening of excavated soil/fill during intrusive work for indications of contamination by visual means, odor, and monitoring with a PID.
10. Installation of a storm-water pollution prevention system in compliance with applicable laws and regulations.
11. Performance of activities required for the remedial action, including permitting requirements and pretreatment requirements, in compliance with applicable laws and regulations.
12. Submission of a FER that describes the remedial activities, certifies that the remedial requirements have been achieved, includes a SMP, defines the Site boundaries, and describes Engineering and Institutional Controls to be implemented at the Site, and lists changes or modifications from this RAWP.
13. Submission of an approved Site Management Plan (SMP) in the FER for long-term management of residual contamination, including plans for operation, maintenance, monitoring, inspection and certification of Engineering and Institutional Controls and reporting at a specified frequency.
14. Recording of an Environmental Easement (EE) that includes a listing of Engineering Controls and a requirement that management of these controls must be in compliance with an approved SMP; and Institutional Controls including prohibition of the following: (1) use of groundwater without treatment rendering it safe for the intended use; (2) disturbance of residual contaminated material unless it is conducted in accordance with the SMP; and (3) higher level of land usage without NYSDEC and NYSDOH approval.

## **7.7 Community Acceptance**

This evaluation criterion addresses community opinion and support for the remedial action. Observations here will be supplemented by public comment received on the RAWP. To date, questions regarding the Site have not been raised regarding the completed RIR. Original AAR/ RAWP was submitted to NYSDEC and NYSDOH on March 12, 2015 and was subject to a 45-day public comment period to determine if the community has any comments on the presented remedial alternatives and selected remedy. No comments were received regarding the selected remedy during the public comment period. This revised AAR/RAWP has been edited to remove all reference from the original AAR/RAWP to use a building and improvements as part of the Site wide Engineered Cover system and that the proposed remedy will be sufficient for a protective restricted residential or commercial use. The remainder of the original AAR/RAWP remains as originally described. VOA is requesting formal approval of this revised AAR / RAWP.

## **7.8 Standards, Criteria and Guidance**

The Standards, Criteria and Guidance (SCGs) utilized as part of this RAWP were identified in Section 4.0 of the draft AAR for Part 375-6.8(b) Restricted Residential Use SCOs.



## 7.9 Summary of the Remedial Goals

The proposed future use for the Site is re-development for restricted residential use. As such, at a minimum, the remedy must eliminate or mitigate known significant threats to public health and/or the environment presented by the impacts identified at the Site through the proper application of scientific and engineering principles.

The Remedial Goals for this Remedial Action Work Plan are as follows:

- a. Remove and reuse or dispose of historic fill material excavated to backfill excavation, the storm water conveyance system, and utilities below the demarcation marker and side wide engineered cover system.
- b. Remove and dispose grossly contaminated historic fill (Black Stained Sandy Soils) impacted with significant SVOC and PAH compounds, VOCs with nuisance characteristics (odor) in the area of near the northern portion of the Site.
- c. Cover entire site with an engineered cover system that includes imported clean soil and asphalt.
- d. Remove and properly dispose a section of the former railroad spur that overlies the impacted soil excavation area.
- e. Place an environmental easement on the property.
- f. Implement engineering controls and institutional controls at the Site.
- g. Perform annual certification of the engineering and institutional controls.
- h. Prepare and implement a SMP to manage EC, IC and historic fill excavated during future invasive actions at the Site after the remediation is completed.

All work will be completed in accordance with NYSDEC DER-10, applicable local, state, and federal regulations.

## 7.10 Remedial Action Objectives

Based on the results of the RIR and draft AAR, the following Remedial Action Objectives (RAOs) have been identified for this Site:

### Soil

- Prevent direct contact with contaminated soil.
- Prevent exposure to contaminants volatilizing from contaminated soils.
- Reduce infiltration of run-off into the fill soils.

### Soil Vapor

- Prevent exposure to contaminants in soil vapor.
- Prevent migration of soil vapor into future on-site buildings using EC.

### Groundwater

- Prevent direct exposure to contaminated groundwater.
- Prevent exposure to contaminants volatilizing from contaminated groundwater.
- Reduce infiltration of run-off into the groundwater.

## 7.11 Remedial Alternatives Analysis

The goal of the remedy selection process is to select a remedy that is protective of human health and the environment taking into consideration the current, intended and reasonably anticipated future use of the property. The remedy selection process begins by establishing RAOs for media in which chemical constituents were found to be in exceedance of applicable standards, criteria and guidance values (SCGs). A remedy is then developed based on the following ten criteria:

- Protection of human health and the environment;
- Compliance with SCGs;
- Short-term effectiveness and impacts;
- Long-term effectiveness and permanence;
- Reduction of toxicity, mobility, or volume of contaminated material;
- Implementability;
- Cost effectiveness;
- Community Acceptance;
- Land use; and
- Green Remediation

## 8.0 REMEDIAL ACTION

The preferred remedial action is a site-wide engineered cover system over historic fill soils with excavation and off-site disposal of Black Stained Sandy Soils source area. Additional historic fill excavated from the Site may be disposed of off-site or re-used on-Site as backfill. This remedial action also includes engineering and institutional controls.

### 8.1 Summary of Preferred Remedial Action

The preferred remedial action alternative is Alternative #3 as presented in the AAR. This preferred remedial action alternative achieves protection of public health and the environment for the intended use of the property. The preferred remedial action alternative will achieve the remedial action objectives established for the project and addresses applicable SCGs. The preferred remedial action alternative is effective in both short-term and long-term effectiveness and reduces mobility, toxicity and volume of contaminants. The preferred remedial action alternative is cost effective and implementable and uses standards methods that are well established in the environmental remediation industry. This preferred remedial action alternative is a permanent solution for remediation of the environmental conditions presented in the RIR.

The proposed remedial action will consist of:

1. Implementation of a Citizen Participation Plan.
2. Perform a Community Air Monitoring Program for particulates and volatile organic carbon compounds.
3. Achieve a Track 4 Restricted Residential level remedy by implementation of the proposed remedy.
4. Collection and analysis of post-excavation confirmatory sidewall and end-point bottom soil

samples in of the Black Stained Sandy Soil excavation area to determine the performance of this portion of the remedy with respect to a comparison with Track 4 restricted residential remedy and complete the delineation of soil impacts.

Collection and analysis of 4 sidewall and 2 bottom confirmatory soil samples will be completed in accordance with NYSDEC DER-10 to confirm that the excavation and removal of the Black Stained Sandy Soil source area is complete and will allow for evaluation of levels of COCs that remain post-excavation along the sidewalls and at the bottom of the excavation. Collection of confirmatory bottom samples will be performed from the open excavation at approximately 18 to 20 feet below the ground surface. The sample depth interval into the floor (bottom) of the excavation will be 0-6 inches within 24 hours of completion of the excavation to final depth or 6-12 inches, if the sample is collected after 24 hours.

Sidewall soil samples will be collected after the excavation is backfilled to the ground surface and the sheet pile shoring are removed. A rotary drill rig will be used to advance 4 soil borings adjacent to the sidewalls of the excavation area with continuous split spoon sampling through the zone of contamination that is from approximately 6 feet to 20 feet below ground surface. Each soil sample will be field screened with a Photoionization detector (PID). Samples that exhibit elevated PID measurements, nuisance odors, and or visual staining will be selected for laboratory analysis.

Laboratory analysis will include NYSDEC ASP Category B deliverables in accordance with:

- Method 8260 for Volatile organic compounds
- Method 8270 for Semi-volatile organic compounds
- TAL Metals
- Method 8015 Diesel Range Organics

5. Installation of a vapor barrier system beneath future on-Site building(s).
6. Installation and operation of a soil vapor mitigation system designed as an active SSDS to address the potential for vapor intrusion into future on-Site buildings.
7. Import of clean soils to be used for excavation backfill and for Site-wide engineered cover system in accordance with NYSDEC DER-10.
8. Transportation and off-Site disposal of excavated historic fill/soil and fill materials that cannot be reused on-Site under the site wide engineered cover or in excavations at permitted facilities in accordance with applicable laws and regulations for handling, transport, and disposal, and this plan. Sampling and analysis of excavated soil and fill materials as required by disposal facilities and NYSDEC. Appropriate segregation of excavated soils and fill materials on-Site will be allowed during remediation activities.
9. Screening of excavated soil/fill during intrusive work for indications of contamination by visual means, odor, and monitoring with a PID.
10. Implementation of storm water pollution prevention measures in compliance with applicable laws and regulations during remediation construction activities. Installation of a storm water detention system below the demarcation marker.

11. Performance of activities required for the remedial action, including permitting requirements and pretreatment requirements, in compliance with applicable laws and regulations.
12. Submission of a FER that describes the remedial activities implemented, certifies that the remedial requirements have been achieved, includes a SMP, defines the Site boundaries, and describes all ECs and ICs to be implemented at the Site, and lists changes and modifications from this RAWP.
13. Submission of an approved Site Management Plan (SMP) in the FER for long-term management of residual contamination, including plans for operation, maintenance, monitoring, inspection and certification of ECs and ICs and reporting at a specified frequency.
14. Recording of an Environmental Easement that includes a listing of ECs and a requirement that management of these controls must be in compliance with an approved SMP; and ICs including prohibition of the following: (1) use of groundwater without treatment rendering it safe for the intended use; (2) disturbance of residual contaminated material unless it is conducted in accordance with the SMP and (3) higher level of land usage without NYSDEC and NYSDOH approval.

## **8.2 Soil Cleanup Objectives and Soil/Fill Management**

The remedial goal is a Track 4 restricted residential remedy to accommodate future re-development for restricted residential use. Soil and materials management on-Site and off-Site, including excavation, handling and disposal and placement of a Site-wide engineered cover system will be conducted in accordance with the RAWP, NYSDEC DER-10, and BCP requirements.

## **8.3 Soil Fill Removal and Off-Site Disposal**

The cleanup plan requires the excavation of historic fill soils and fill materials from areas in which the storm water detention system will be constructed with the proposed grading of the Site to create a stable surface upon which to construct the site wide engineered cover system. Additionally, grossly contaminated historic fill (Black Stained Sandy Soils area) in the northern area of the Site will be excavated and disposed off-Site. This work will include:

- For grading purposes, unsuitable fill soils / historic fill soils will be used as backfill and as fill under the demarcation marker and below the site wide engineered cover system, including the existing railroad ties / rails; historic fill soils and fill materials that is present between the ties; and portions of stockpiled soil berms. Figure 7 shows the approximate extent of the areas that currently contain these materials. Materials that are too large to place and compact below the site wide engineered cover system will be properly disposed off-Site. These materials may include:
  - Railroad ties in the area of the proposed impacted soil excavation.
  - Railroad steel tracks in the area of the proposed soil excavation will be scraped at a recycling facility.
  - Fill material such as large pieces of wood and concrete will be properly disposed off-Site.
- The vegetation, scrubs and trees be excavated and removed from the Site using a bulldozer, excavator, loader, or other appropriate equipment for transportation and off-Site disposal.
- In the areas of proposed the Black Stained Sandy Soils source area (grossly contaminated Historic fill) and in other areas where additional excavation may occur and require additional

- off-Site disposal, historic fill soils and or fill materials will be excavated using an excavator, loader or other appropriate equipment.
- A Bergmann scientist or engineer will screen the removed historic fill soils or fill materials for visual and olfactory observations and for total volatile compounds using a photoionization detector (PID).
  - Based on the screening results, the excavated historic fill soils and fill materials will be segregated into one of several classes of material and staged in discrete piles (or directly loaded into trucks). The Table below identifies the class of materials criteria for segregation of excavated historic fill soils and fill materials with the anticipated estimated volumes of each type of material.
  - Historic fill soils and fill materials that are not directly-loaded onto trucks for off-site disposal will be segregated by class, as shown in the Table below, and handled, stockpiled, and characterized accordingly for potential on-Site re-use. Each stockpiled of soil or fill material will be labeled with type of materials and date that the stockpile was made.

### Estimated Soil/Fill Removal Quantities and Class Segregation Plan

Class of Material	General Physical Description
Class 1	Fill materials exhibiting with PID measurements of less than 10 ppm
Class 2	Fill materials exhibiting with PID measurements of more than 10 ppm
Class 3	Slightly to non-impacted soils
Class 4	Railroad Ties and Rails
Class 5	Concrete, wood, and miscellaneous materials

- Excavated historic fill soils and fill materials to be stockpiled on-Site will be placed on and covered by a minimum of double 6-mil polyethylene sheeting, which is sufficiently anchored to prevent any wind and water erosion. The cover will be inspected at least once per day with corrective action taken as needed. The inspections and any corrective actions will be documented in logs and will occur until the historic fill soils / fill materials have been properly removed and disposed off-Site or characterized for potential re-use on-Site.
- Characterization sampling of the stockpiled historic fill soils and fill materials (Classes 1 through 5) will conform to the requirements of the facility at which the material is planned to be disposed or in accordance with NYSDEC DER-10 for potential re-use on-Site.
- The final, off-Site disposal location will be based on the characterization data obtained at the time of the work and at a facility approved for such waste.
  - Class 1, 2 and 5 materials may be disposed at Riga Landfill in the Town of Chili, New York.
  - Class 3 Existing stockpiled (soil piles and former Bio-cell soils) materials may also be disposed at the Riga Landfill or may be used under the cover system or in the soil removal excavation.
  - Class 4 Railroad ties and rails will be disposed of at an approved facility.
- Excavation and handling of the non-impacted soils contained in the former bio-cells and slightly impacted soil berms (soil piles) along the eastern property line (Class 3 Materials) will include:



- The use of existing soil berms located along the eastern property line as backfill in the Black Sandy Soils Area excavation and under the demarcation marker and site wide engineered cover system. Excess soils will be characterized for off-Site disposal.
- Note: Native soils are located approximately 20 to 45 feet below the ground surface and will not be excavated or handled during the planned remediation or building construction.
- The excavation of the grossly contaminated Black Stained Sandy Soils area (Class 2) will proceed based on the following:
  - Sheet piling and shoring will be installed in order to perform the excavation work. The approximate limits of Black Sandy Soils area defined in the RIR (35 ft. X 35 ft. X 20 ft.) will be excavated.
  - The excavation activities will be terminated at approximately 18 ft. to 20 foot depth. This depth range is the maximum extent of the proposed excavation and reach of the excavator.
  - Post-excavation confirmation sampling from the bottom of the excavation of the Black Sandy Soil Area will be completed to evaluate the levels that remain that may exceed the SCOs. (Note: the EC for a sub-slab depressurization system and the Site wide engineered cover system will be required in future buildings as per detailed in the SMP.)
- All soil classes will be field screened with a PID and monitored as excavations proceed through the remediation program. This will allow for determination for segregation of materials to be characterized for off-site disposal or re-use on-Site.
- Good housekeeping practices will be followed during excavation activities to prevent placement of excavation contaminated soils and fill material on the ground surface (e.g., precautions will be taken to prevent impacts to the ground surface due to soils and material spilled from the excavator bucket and trucks). Contaminated historic fill soils and fill materials that spill on to the ground surface will be promptly picked up and placed in an appropriate location (e.g., dump truck, fill stockpile, etc.).
- Transportation of all wastes will be completed by properly permitted vehicles.
- To the extent practicable, trucks will travel along routes that avoid residential areas.
- Historic fill soil and fill materials excavated from the Site and sent for off-Site disposal will not be re-used at other sites. All excavated historic fill soil and fill materials that are transported off-Site will be properly disposed at a permitted landfill.

The estimated quantity of historic fill soil and fill materials expected to be excavated and disposed off-Site is approximately 1,500 tons. This quantity may change due to field conditions encountered to complete the remediation. Disposal facilities will be reported to NYSDEC when they are identified and prior to the start of remedial action.

#### **8.4 Source Soil Removal Excavation**

A source soil excavation is required for removal and off-Site disposal of the Black Stained Sandy Soil source area, which will be performed to remove this limited area of the historic fill with different physical and chemical characteristics when compared to the rest of the historic fill that is primarily ash / cinders and free of vapor / odors. The characteristics of the Black Stained Sandy Soil include: elevated organic vapors, black stained color, sandy silt soils, creosote odors, and elevated concentrations of mid-range diesel organics (2,200 ppm). Soils in this area have the highest contaminant levels on the Site (source area). This area is approximately 35 ft. X 35 ft. and approximately 20 feet deep. This area will be excavated to a depth of approximately 18 to 20 feet. The approximate quantity to be excavated is 1,000 yds<sup>3</sup> or on the order of 1,500 tons of historic fills soil. It should be noted that the quantity of this source area soil to be excavated under this alternative is based on RI test pit excavations completed for delineation of this area and RI laboratory soil sample results. The actual quantity would be finalized in the field during Site excavation activities. The

approximate location of this excavation area is shown on Figure 12. Dewatering is not anticipated during the soil source removal excavation activities under this alternative. However, sheeting and shoring will be required during excavation activities to the approximate depth of 20 feet. An engineer's excavation plan will be prepared by VOAs remediation contractor to address the requirements for this excavation to be followed by VOA's contractors. VOA's contractors will be prepared to handle and manage groundwater that may enter the excavation and odor / dust suppression that will likely be required.

### 8.5 Backfill

Following completion, the source area excavation will be backfilled to pre-existing grade or proposed final grade of the redevelopment in accordance with VOA's civil engineer's requirements. Imported clean soils and or existing soils stockpiled on the Site from the remediated bio-cells and or soil berms (piles) may be used to backfill this excavation. Use of the soil (piles) berms for backfill may require additional characterization meet NYSDEC DER-10, BCP, and geotechnical requirements. Imported clean soils may be used to complete the backfilling of this excavation or may be used to backfill the entire excavation.

Other Site excavations will be backfilled with existing soils stockpiled or clean imported soils to facilitate the installation of the storm water detention sewer system, soil cover system and underground utilities. The backfill will include soil, stone and gravel specified by VOA's civil engineers necessary for remediation construction. Soils from existing stockpiles / bio-cells and site historic fill soils used as backfill will be placed below the demarcation marker.

For each source of backfill that is imported to the Site, one of the following will be completed prior to importing the backfill.

- a. Documentation will be provided to NYSDEC as to the source of the material and the consistency of the material in accordance with the exemption for no chemical testing listed in DER-10 Section 5.4(e)(5); or
- b. Chemical testing will be completed in accordance with the following table:

Recommended Number of Soil Samples for Soil Imported To or Exported From a Site			
Contaminant	VOCs		SVOCs, Inorganics & PCBs/Pesticides
	Discrete Samples	Composite	Discrete Samples/Composite
Soil Quantity (cubic yards)			
0-50	1	1	3-5 discrete samples from different locations in the fill being provided will comprise a composite sample for analysis
50-100	2	1	
100-200	3	1	
200-300	4	1	
300-400	4	2	
400-500	5	2	
500-800	6	2	
800-1000	7	2	
1000	Add an additional 2 VOC and 1 composite for each additional 1000 Cubic yards or consult with DER		

(Note: Table information is from DER-10 - Table 5.4(e) 10)

In the event that laboratory analytical testing is conducted, the results for each new source of fill must meet the values provided in Appendix 5 of DER-10 for commercial use and must receive approval by the NYSDEC. Reuse of on-Site soils requires NYSDEC approval prior to placement as backfill and may also require characterization tests. Prior to performing backfilling activities with imported soils, all equipment that has come into contact with impacted soils will be decontaminated on the decontamination pad.

## 8.6 Site- Wide Engineered Cover System Construction

To eliminate potential exposure to the historic fill material at the surface of the Site, a Site-wide engineered cover system (cover system) will be installed across the entire Site as shown on Figure 13. The cover type will vary across the Site based on existing improvements and will consist of the following:

### Cover System Details

Cover Type	Cross-Section
Asphalt (Pavement)	Asphalt 4 inches Sub-base - 18 inches
Existing Lawn	Installed during 1998 Topsoil 2 inch & 22 inch soil
Existing Asphalt	Installed during 1998 – repair by sealing cracks

Prior to placement of the cover system, rough grading will be performed using a bulldozer and on-site stockpiled / bio cell soils to be compacted below the demarcation marker in accordance with VOA's civil engineer's requirements. The Site historic fill soils and on-site soil fill materials place to grade the Site will be covered by a demarcation layer (geotextile or snow fencing). Imported clean soils (sub-base 18 inches) will be compacted and placed above the demarcation marker. The soils used in the sub-base will be imported from an approved source and documentation will be provided to demonstrate that the imported soil conforms to NYSDEC DER-10 requirements for backfill soils. The sub-base will be placed, spread with a bulldozer, and properly compacted to minimize future settling in accordance with VOA's civil engineer's requirements. A 4-inch thick asphalt layer will be placed and compacted after the sub-base is installed and compaction tests are completed.

The area of the western side of the Site has existing pavement roadway / parking lot and grass cover areas associated with the VOA Human Service Complex and were installed during the redevelopment of VOA's Human Service Complex facility during 1998. The existing pavement cover areas will require seals to cracks in the pavement and will remain as pavement areas that are part of the cover system. The limited existing grass cover areas will remain in place. Future maintenance and inspection will be detailed in the SMP.

Following placement of the site-wide cover system, annual inspections will be performed in accordance with the SMP. Future excavations on the Site will follow the soil management requirements in the SMP.

## 8.7 Confirmation End-Point Sampling

Removal actions under this plan to excavate the source area of Black Stained Sandy Soils will be performed in conjunction with confirmation end-point sampling. Confirmation end-point sampling

frequency will consist of the following:

1. One sample from the bottom of each sidewall for every 35 linear feet of sidewall and one sample from the center of the excavation bottom.
2. For sampling of volatile organics, bottom samples shall be taken within 24 hours of excavation, and shall be taken from the zero to six-inch interval at the excavation floor. Samples taken after 24 hours should be taken at six to twelve inches below the bottom of the excavation.
3. For contaminated soil removal, post remediation soil samples for laboratory analysis shall be taken immediately after contaminated soil removal.

Post-remediation sample locations and depth will be biased towards the areas and depths of highest contamination identified during previous sampling unless field indicators such as field instrument measurements or visual contamination identified during the remedial action indicate that other locations and depths may be more heavily contaminated. In all cases, post-remediation samples should be biased toward locations and depths of the highest expected contamination.

A New York State ELAP certified laboratory will be used for end-point sample analyses. The laboratory reports for end-point sample analyses will be included in the FER. The FER will provide a tabular and figure summary of the locations for end-point sample results and will include data for non-detects, detection concentrations and applicable standards and/or guidance values. End-point samples will be analyzed for COC target analyses (those for which SCO exceedances are identified) utilizing the following methodology:

Soil analytical methods will include:

- Semi-volatile organic compounds by EPA Method 8270;
- Target Analyte List metals;
- Volatile organic compounds by EPA Method 8260; and
- Diesel Range Organics by EPA Method 8015

## **8.8 Quality Assurance/Quality Control**

The fundamental QA objective with respect to accuracy, precision, and sensitivity of analysis for laboratory analytical data is to achieve the QC acceptance of the analytical protocol. The accuracy, precision and completeness requirements will be addressed by the laboratory for all data generated.

Collected samples will be appropriately packaged, placed in coolers and shipped via overnight courier or delivered directly to the analytical laboratory by field personnel. Samples will be containerized in appropriate laboratory provided glassware and shipped in plastic coolers to the laboratory within 48 hours of sample collection. Samples will be preserved through the use of ice or "cold-paks" to maintain a temperature of 4°C.

Dedicated disposable sampling materials will be used for the collection endpoint confirmatory soil samples, eliminating the need to prepare field equipment (rinsate) blanks. However, if non-disposable equipment is used, (stainless steel scoop, etc.) field rinsate blanks will be prepared at the rate of 1 for every eight samples collected. Decontamination of non-dedicated sampling equipment will consist of the following:

- Gently tap or scrape to remove adhered soil
- Rinse with tap water
- Wash withalconox® detergent solution and scrub
- Rinse with tap water
- Rinse with distilled or deionized water

Prepare field blanks by pouring distilled or deionized water over decontaminated equipment and collecting the water in laboratory provided containers. Trip blanks will be used whenever samples are transported to the laboratory for analysis of VOCs. Trip blanks will not be used for samples to be analyzed for metals, SVOCs or pesticides. One blind duplicate sample will be prepared and submitted for analysis every 20 samples.

## **8.9 Engineering Controls**

ECs are part of the remedial action to address residual contamination remaining at the Site, as detailed in the SMP, after the soil removal efforts and construction of the Site-wide engineered cover system are completed (completed remediation). The Site has three primary Engineering Control Systems. These are:

- soil vapor barrier required under future Site buildings;
- active sub-slab depressurization system (SSDS) required under future Site buildings to mitigate potential vapor intrusion into future Site buildings; and
- Annual inspection maintenance of the Site-wide engineered cover system.

### Vapor Barrier

Potential migration of soil vapor will be mitigated to prevent the potential for vapor intrusion condition into future Site slab on grade buildings with a combination of building floor slab, vapor barrier and active SSDS. A high density polyethylene vapor barrier liner (HDPE) will be required over the SSDS suction pits and vapor mitigation vent piping prior to construction of future buildings concrete floor slabs. The vapor barrier will consist of a 20 mil HDPE geomembrane liner manufactured by GSE Lining Technologies of North America, or equivalent. The vapor barrier will extend throughout the area occupied by the footprint of future buildings. Specifications for installation will be in accordance with the manufacturer's requirements to be followed by VOA's contractor and installer of the liner. Specifications state that vapor barrier seams, penetrations, and repairs to punctures will be sealed either by the tape method or weld method, according to the manufacturer's recommendations and instructions.

The photographs of the future vapor barrier installation process, PE certified letter (on company letterhead) from primary contractor responsible for installation oversight and field inspections, and a copy of the manufacturer's certificate of warranty.

### Sub-Slab Depressurization System (SSDS)

Migration of potential soil vapor into the Site building will be mitigated with the construction of an active SSDS below future slab on grade on site buildings. The SSDS will be installed beneath future buildings vapor barrier and floor slab. The SSDS beneath the slab will be designed and installed in general accordance with EPA Radon Prevention in the Design and Construction of School and other Large Buildings, June 1994 or on future requirements for SSDS. This primary design uses a series of



suction pits constructed with permeable washed gravel and sealed below the vapor barrier connected to a length of perforated horizontal pipe in the gravel suction pit. The horizontal pipe will extend to an adjacent chase-way or building column where it will be piped vertically to the roof via a 4-inch or 6-inch schedule 40 PVC pipe. An in-line radon style blower motor will be fitted to the 4-inch or 6-inch vent line. The vent exhaust stack at the roof will be located a minimum of 10 feet from windows and ventilation inlets and approximately 3 to 4 feet above the top of the roof. The section of vent pipe above the roof should be schedule 40 CPVC pipe and fitted with a tee. Visual and audible alarms will be connected to the SSDS to indicate any failure of the system's blower motor.

#### Site-Wide Engineered Cover System

The Site-wide cover system, which is part of the remedy, is also an engineering control that has to be annually inspected and maintained over time. Annual certifications of the cover system will be made and certified by a NYS Professional Engineer through visual inspections to ensure the cover system is performing the function of properly capping subsurface soils.

### **8.10 Institutional Controls**

Institutional Controls (IC) have been incorporated in this remedial action to manage affected groundwater and potential soil vapor intrusion at the site and render the Site protective of public health and the environment. Institutional Controls are listed below. Long-term employment of EC/ICs will be established in an Environmental Easement (EE) assigned to the property by the title holder, which will run with the land, and will be implemented under a site-specific Site Management Plan (SMP) that will be included in the FER.

Institutional Controls for this remedial action are:

- Recording of an NYSDEC-approved Environmental Easement (EE) with the Monroe County Clerk. The EE will include a description of required ECs and ICs, will summarize the requirements of the Site Management Plan, and will note that the property owner and property owner's successors and assigns must comply with the EE and the approved SMP. The recorded EE will be submitted in the FER. The EE will be recorded prior to NYSDEC issuance of the Notice of Completion;
- Submittal of a SMP in the FER for approval by NYSDEC that provides procedures for appropriate operation, maintenance, monitoring, testing, inspection, reporting and certification of ECs. SMP will require that the property owner and property owner's successors and assigns will submit to NYSDEC a periodic written statement that certifies that: (1) controls employed at the Site are unchanged from the previous certification or that any changes to the controls were approved by NYSDEC; and, (2) nothing has occurred that impairs the ability of the controls to protect public health and environment or that constitute a violation or failure to comply with the SMP. NYSDEC retains the right pursuant to the terms in the EE to enter the Site in order to evaluate the continued maintenance of these controls. This certification shall be submitted annually and will comply with currently applicable NYSDEC DER-10 guidance document and BCP requirements.
- Use of groundwater underlying the Site is prohibited without treatment rendering it safe for its intended use.
- The redevelopment use of the Site is limited to restricted residential, commercial or industrial. Other use must be approved by the NYSDEC and NYSDOH.

## 8.11 Site Management Plan

A Site Management Plan (SMP) will be developed for the entire Site. The primary intent of this document will be to provide methods and procedures to manage contaminated soil remaining at the Site under the demarcation barrier and to restrict groundwater use at the Site. This document will be developed and submitted for regulatory approval at the completion of remedial activities. The SMP will be implemented when the remediation construction is completed.

The SMP will include the following:

- Identification of specific areas of residual impacted fill that remain on-Site and illustrate these areas on figures.
- A SMP identifies proper handling, characterization, transportation and disposal requirements for the various impacted historic fill soils and fill materials should such materials be encountered during Site redevelopment or future construction activities (e.g., underground utility work). This Soil Management Plan will include provisions for groundwater monitoring as appropriate for post-remediation monitoring.
- An Operation, Maintenance and Monitoring (OM&M) Plan for the Site that includes the requirements for cover system annual certification and OM&M for the SSDS, as appropriate.
- Indicate that groundwater cannot be used as a source of drinking water or extracted for any reason without prior approval from regulatory agencies.
- Indicate that the Site use and groundwater use restrictions are part of an environmental easement and will include a copy of the easement.
- Indicate that these restrictions are recorded with the Monroe County Clerk.
- Indicate that an annual certification be submitted to NYSDEC certifying that the requirements of the SMP were adhered to.
- The environmental easement that indicates the above requirements and the SMP will be recorded with the Monroe County Clerk and will be provided to NYSDEC prior to finalizing/recording these documents.
- The SMP will be included in the FER.

Site Management is the last phase of remediation and begins with the approval of the FER and issuance of the Notice of Completion (NOC) for the Remedial Action. The Site Management Plan (SMP) describes appropriate methods and procedures to ensure implementation of all ECs and ICs that are required by NYSDEC / NYSDOH and this RAWP. The SMP is submitted as part of the FER but will be written in a manner that allows its use as an independent document. Site Management continues until terminated in writing by NYSDEC. The current property owner at any given time is responsible to ensure that all Site Management responsibilities defined in the EE and the Site Management Plan are implemented.

The SMP will provide a detailed description of the procedures required to manage residual soil/fill left in place following completion of the remedial action in accordance with the Brownfield Cleanup Agreement with NYSDEC. This includes a plan for: (1) implementation of EC's and ICs; (2) implementation of the groundwater monitoring program; (3) operation and maintenance of EC's; (4)

inspection and certification of EC's; (5) Excavation Plan and (6) reporting.

Site management activities, reporting, and EC/IC certification will be scheduled on a periodic basis to be established in the SMP and will be subject to review and modification by NYSDEC. The Site Management Plan will be based on a calendar year and certification reports will be due for submission to NYSDEC by March 31 of the year following the reporting period.

### **8.12 Construction Water Management**

This section identifies proper handling, treatment and discharge procedures for groundwater and/or rainwater that may enter excavations during remediation/redevelopment activities. Contractors performing subsurface work at the Site will be required to provide temporary dewatering to handle groundwater and storm water run-in to excavations during the remedial/redevelopment activities. Dewatering methods may include the use of sumps and pumps or the installation of well points. The water will be pumped or hauled from the collection points to the ground surface at on-site locations of and stored in tanks for settlement of solids pre-treatment and testing of waters for discharge to the sanitary sewer system. Water that fails the sewer limit codes for discharge will be transported by the Contractor to a waste treatment plant or other permitted disposal facility.

### **8.13 Erosion, Dust, and Odor Controls**

As part of the remedial actions to be performed at the Site, measures will be needed to limit erosion and dust generation. Erosion control and dust suppression techniques will be employed by VOA's Contactor as necessary to limit erosion and fugitive dust generated in disturbed areas during remediation and redevelopment construction activities. Such techniques may be employed even if the community air monitoring results indicate that particulate levels are below action levels. Techniques may include but are not limited to:

- Using silt fencing, Straw bales, and/or mulching
- Applying water on haul roads
- Wetting equipment and excavation surfaces
- Hauling materials in properly tarped or watertight containers
- Limiting vehicle speed on the Site
- Limiting the size of excavations
- Covering excavated areas and materials following excavation
- Adding biosolve® to excavations to reduce odors

Effectiveness of the dust and odor suppression measures will be evaluated based on the results of the air monitoring that will be conducted under the Community Air Monitoring Plan.

### **8.14 Storm Water Management**

Storm water management is an important component of the remedial construction at the Site. A Storm water Pollution Prevention Plan (SWPPP) will be developed by VOA's civil engineer to help control runoff and pollutants during remedial construction at the Site by VOA's remediation contactor. A storm water detention system is to be installed below the demarcation marker for permanent storm water management.

The following subsections comprise the SWPPP as it relates to the remedial construction activities,

and were developed in general accordance with the NYSDEC's *Instruction Manual for Storm water Construction Permit*, July 2004. VOA's contractor will comply with all the applicable local, state, and federal regulations.

#### Storm water Management Objectives

The principal objective of this SWPPP is to comply with the NYSDEC SPDES Storm water requirements for remedial construction activities by planning and implementing the following practices:

- Reduction and/or elimination of erosion and sediment loading to water bodies during remedial construction.
- Maintenance of storm water controls during remedial construction.

As discussed previously, the storm water management structures and procedures necessary to address post-remediation storm water will be addressed during final design of the VOA PACE Center facility.

#### **8.15 Erosion and Sediment Control**

Every effort will be made to minimize erosion and sediment runoff during remedial construction. Measures described in Section 9.14 will be implemented to control the migration of sediment from the Site.

#### **8.16 Monitoring Well Decommissioning**

A number of RI monitoring wells currently exist on-site. Because groundwater does not exhibit significant impacts in all areas of the site, requirements for long-term groundwater monitoring will be required for a minimum period of 5 years and the methods and procedures for monitoring will be presented in the SMP. Groundwater samples will be collected from a reduced number of monitoring wells that exist at the Site from the RI. On-Site RI monitoring wells MWR – 101, MWR – 102, MW-102, and MW-104 will be abandoned to facilitate the construction of the cover system. Two monitoring wells from previous investigations will also be abandoned / decommissioned in accordance with the procedures listed in NYSDEC's *CP-43: Groundwater Monitoring Well Decommissioning Policy, November 2009*. The abandonment and decommissioning of these wells will include:

- Removing the protective casing and riser pipe
- Excavating the concrete surface seal
- Injecting grout into the bottom of the well via a tremie pipe
- Removing the upper five feet of well casing
- Backfilling the upper five feet with clean fill
- Preparing decommissioning logs that will be included as an attachment in the FER

Groundwater monitoring wells MW-101, MW-103, MW-105, MW-106, and MW-107 will be maintained and protected throughout the remediation. These monitoring wells will be sampled as part of the groundwater monitoring program to be provided in the SMP. Modifications to monitoring well surface completions and extensions of well casings maybe required depending on the elevations of the ground surface for the redevelopment. All information regarding proposed modifications to monitoring wells will be provided to NYSDEC.

### **8.17 Decontamination**

To prevent cross-contamination to surrounding ground surface areas, vehicles (excavators & trucks) and equipment that contact Site soils and groundwater will be decontaminated prior to leaving the Site. A decontamination pad will be constructed on-site and the size will be large enough to accommodate the placement of equipment requiring decontamination.

Water utilized for decontamination will be containerized and handled in the same manner as any construction water, as discussed in Section 9.12.

The tracking of site soil/fill onto public streets will not be permitted, and provisions will be made to ensure that any soils or material tracked off-site will be addressed via a truck wash and street-sweeping or other practical means.

## **9.0 REMEDIAL ACTION MANAGEMENT – Project organization & Oversight**

Principal personnel who will oversee the remedial action performed by VOA's contractors include: Charlotte Theobald, Project Manager-NYSDEC. The Professional Engineer (PE) and Qualified Environmental Professional (QEP) for this project are James Basile, P.E. of Bergmann Associates and Stephen DeMeo, Senior Geologist of Bergmann Associates.

### **9.1 Site Security**

Site access will be controlled by a chain link fence which surrounds the northern, eastern and southern Site boundary. A temporary fence will be installed with a locking gate along the western side of the Site. Site security during remediation activities is the responsibility of VOA's remediation contractor.

### **9.2 Work Hours**

The hours of operation for remedial construction will conform to the City of Rochester Department of Buildings construction code requirements or according to specific variances issued by the City of Rochester.

### **9.3 Construction Health and Safety Plan**

The Site-specific Construction Health and Safety Plan (CHASP) will be developed by VOA's contractor. The Site Safety Coordinator will be designated by VOA's contractor. The remedial work performed under this RAWP will be in full compliance with applicable laws and regulations, including Site and Occupational Safety and Health Administration (OSHA) worker safety requirements and HAZWOPER requirements. Confined space entry, if any, will comply with all OSHA requirements and industry standards and will address potential risks. VOA's remediation contractor will ensure that performance of remediation work is in compliance with the CHASP and applicable laws and regulations. The CHASP pertains to remedial work performed at the Site. Safety Data Sheets (SDS) for identified contaminants of concern (COC) on-site or contaminant constituents will be included in the CHASP. Field personnel involved in remedial activities will have been trained as required under 29 CFR 1910.120, including 40-hour HAZWOPER and the annual 8-hour refresher training. VOA's Contractor will be the Site Safety Officer and will be responsible for maintaining workers training records on the Site.



VOA's contractor personnel and visitors entering the Site will be trained in the provisions of the CHASP prepared by VOA's contractor and be required to sign a CHASP acknowledgment. Site-specific health and Safety items will be presented to field personnel by VOA's contractor. Emergency telephone numbers will be posted at the Site location before any remedial work begins. A safety meeting will be conducted before each shift begins. Topics to be discussed include task hazards and protective measures (physical, chemical, environmental); emergency procedures; Personal Protective Equipment (PPE) levels and other relevant safety topics. Meetings will be documented in a log book or specific form by VOA's contractor.

#### **9.4 Community Air Monitoring Plan**

Real-time air monitoring for volatile organic compounds (VOCs) and particulate levels at up-wind and down-wind perimeter area of the exclusion zone, work area, or Site boundary will be performed. Continuous monitoring will be performed during ground intrusive activities and during the handling of contaminated or potentially contaminated media. Ground intrusive activities include, but are not limited to, soil excavation, backfilling, stockpiling, handling, excavation or trenching, general Site grading of fill soils.

Periodic monitoring for VOCs will be performed during non-intrusive activities such as the collection of soil and groundwater samples from existing monitoring wells. Periodic monitoring during sample collection, for instance, will consist of taking a reading upon arrival at a sample location, monitoring while opening a well cap or overturning soil, monitoring during well baling/purging, and taking a reading prior to leaving a sample location. Depending upon the proximity of potentially exposed individuals, continuous monitoring may be performed during sampling activities. Exceedances of action levels observed during performance of the Community Air Monitoring Plan (CAMP) will be reported to the NYSDEC Project Manager and included in the Daily Report.

##### VOC Monitoring, Response Levels, and Actions

Volatile organic compounds (VOCs) will be monitored at the downwind perimeter of the immediate work area (i.e., the exclusion zone) on a continuous basis during invasive work. Upwind concentrations will be measured at the start of each workday and periodically thereafter to establish background conditions. The monitoring work will be performed using equipment appropriate to measure the types of contaminants known or suspected to be present. The equipment will be calibrated at least daily for the contaminant(s) of concern or for an appropriate surrogate. The equipment will be capable of calculating 15-minute running average concentrations, which will be compared to the levels specified below.

- If the ambient air concentration of total organic vapors at the downwind perimeter of the work area or exclusion zone exceeds 5 parts per million (ppm) above background for the 15-minute average, work activities will be temporarily halted and monitoring continued. If the total organic vapor level readily decreases (per instantaneous readings) below 5 ppm over background, work activities will resume with continued monitoring.
- If total organic vapor levels at the downwind perimeter of the work area or exclusion zone persist at levels in excess of 5 ppm over background but less than 25 ppm, work activities will be halted, the source of vapors identified, corrective actions taken to abate emissions, and monitoring continued. After these steps, work activities will resume provided that the total organic vapor level 200 feet downwind of the exclusion zone or half the distance to the nearest potential receptor or residential/commercial structure, whichever is less - but in no case less

than 20 feet, is below 5 ppm over background for the 15-minute average.

- If the organic vapor level is above 25 ppm at the perimeter of the work area, activities will be shutdown.

All 15-minute readings must be recorded and be available for NYSDEC personnel to review. Instantaneous readings, if any, used for decision purposes will also be recorded.

#### Particulate Monitoring, Response Levels, and Actions

Particulate concentrations will be monitored continuously at the upwind and downwind perimeters of the exclusion zone at temporary particulate monitoring stations. The particulate monitoring will be performed using real-time monitoring equipment capable of measuring particulate matter less than 10 micrometers in size (PM-10) and capable of integrating over a period of 15 minutes (or less) for comparison to the airborne particulate action level. The equipment will be equipped with an audible alarm to indicate exceedance of the action level. In addition, fugitive dust migration should be visually assessed during all work activities.

- If the downwind PM-10 particulate level is 100 micrograms per cubic meter (mcg/m<sup>3</sup>) greater than background (upwind perimeter) for the 15-minute period or if airborne dust is observed leaving the work area, then dust suppression techniques will be employed. Work will continue with dust suppression techniques provided that downwind PM-10 particulate levels do not exceed 150 mcg/m<sup>3</sup> above the upwind level and provided that no visible dust is migrating from the work area.
- If, after implementation of dust suppression techniques, downwind PM-10 particulate levels are greater than 150 mcg/m<sup>3</sup> above the upwind level, work will be stopped and a re-evaluation of activities initiated. Work will resume provided that dust suppression measures and other controls are successful in reducing the downwind PM-10 particulate concentration to within 150 mcg/m<sup>3</sup> of the upwind level and in preventing visible dust migration.

All readings will be recorded and be available for NYSDEC personnel to review.

## **10.0 SITE PREPARATION**

### **10.1 Utility Marker Layouts, Easement Layouts**

The presence of utilities and easements on the Site will be fully investigated prior to the performance of invasive work such as excavation or building construction under this plan by using, at a minimum contacting DIG Safe NY (U.F.P.O.) within 7 days prior to any excavation work. Underground utilities may pose an electrocution, explosion, or other hazard during excavation or building construction activities. Remediation activities will be performed in compliance with applicable laws and regulations to assure safety. Utility companies and other responsible authorities will be contacted to locate and mark the locations, and a copy of the stake-out ticket will be retained by VOA's contractor prior to the start of excavation or other invasive subsurface activities. Overhead utilities may also be present within the anticipated work zones. Electrical hazards associated with excavation in the vicinity of overhead utilities will be prevented by maintaining a safe distance between overhead power lines and excavation equipment.

Proper safety and protective measures pertaining to utilities and easements, and compliance with applicable laws and regulations will be employed during invasive subsurface remediation work and other work contemplated under this RAWP. The integrity and safety of on-Site and off-Site structures will be maintained by the VOA's contractor during remediation and building construction, excavation or other remedial activity performed under this RAWP.

## **10.2 Pre-Construction Meeting**

NYSDEC and NYSDOH will be invited to attend the pre-construction meeting at the Site with VOA's contactors and consultants in the remedial process prior to the start of remedial construction activities.

## **10.3 Mobilization**

Mobilization will be conducted as necessary for each phase of work at the Site. Mobilization includes field personnel orientation, equipment mobilization, marking/staking sampling locations and utility mark-outs. Each field team member will attend an orientation meeting to become familiar with the general operation of the Site, health and safety requirements, and field procedures.

## **10.4 Equipment and Material Staging**

Equipment and materials will be stored and staged in a manner that complies with applicable laws and regulations.

## **10.5 Stabilized Construction Entrance**

Steps will be taken to ensure that trucks departing the site will not track soil, fill or debris off-Site. Such actions may include use of cleaned asphalt or concrete roads or use of stone or other aggregate-based egress paths between the truck inspection station and the property exit. Measures will be taken to ensure that adjacent roadways will be kept clean of project related soils, fill and debris.

## **10.6 Truck Inspection Station**

An outbound-truck inspection station will be set up close to the Site exit. Before exiting the Site, trucks will be required to stop at the truck inspection station and will be examined for evidence of contaminated soil on the undercarriage, body, and wheels. Soil and debris will be removed. Brooms, shovels and potable water will be utilized for the removal of soil from vehicles and equipment, as necessary.

## **10.7 Site Control**

Site control is an important aspect of this remedial program. In order to safeguard the health and safety of Site workers and the general public, access to remedial work areas will be restricted by VOA's remediation contractor. Existing perimeter fencing, temporary fencing and security/surveillance will facilitate Site control. Additionally, temporary construction fencing will be erected around accessible excavations and staging areas to prevent unauthorized personnel from entering these areas as appropriate. Signage will be posted that indicated a Brownfield Site Remediation Project. The details for this sign are listed on the NYSDEC website.

## **10.8 Traffic Control**

Drivers of trucks leaving the Site with soil and fill materials will be instructed to proceed without stopping in the vicinity of the Site to prevent neighborhood impacts. The planned route on local roads for trucks leaving the site will be south on Lake Avenue and State Street to follow on to Interstate 490 westbound to the Chili exit for the Mill Seat Landfill or Via 490 eastbound to other off-site locations.

## **10.9 Demobilization**

Demobilization will include:

- As necessary, restoration of temporary access areas and areas that may have been disturbed to accommodate support areas (e.g., staging areas, decontamination areas, storage areas, temporary water management areas, and access area);
- Removal of sediment from erosion control measures and truck wash and disposal of materials in accordance with applicable laws and regulations;
- Equipment decontamination, and;
- General refuse disposal.

Equipment will be decontaminated and demobilized at the completion of all field activities. Remediation equipment and large construction equipment (e.g., excavators and trucks) will be washed at the truck inspection station as necessary. In addition, remediation derived waste will be appropriately disposed.

## **11.0 REPORTING AND RECORD KEEPING**

### **11.1 Daily Reports**

Daily reports providing a general summary of activities for each day of active remedial work will be sent to the NYSDEC Project Manager by the end of the week. Those reports will include:

- Project number and statement of the activities and an update of progress made and locations of work performed;
- Approximate quantities of material imported and exported from the Site;
- Status of on-Site soil/fill stockpiles;
- A summary of all citizen complaints, with relevant details (basis of complaint; actions taken);
- A summary of CAMP excursions, if any;
- Photograph of notable Site conditions and activities.

The frequency of the reporting period may be revised in consultation with NYSDEC project manager based on planned project tasks. Daily email reports are not intended to be the primary mode of communication for notification to NYSDEC of emergencies (accidents, spills), requests for changes to the RAWP or other sensitive or time critical information. However, such information will be included in the daily reports. Emergency conditions and changes to the RAWP will be communicated directly to the NYSDEC project manager by personal communication. Daily reports will be included as an Appendix in the FER.

## 11.2 Record Keeping and Photo-Documentation

Job-site record keeping for remedial work will be performed. Representative photographs will be taken of the Site prior to any remedial activities and during major remedial activities to illustrate remedial program elements and contaminant source areas. Photographs will be submitted at the completion of the project in the FER in digital format (i.e. jpeg files).

## 11.3 Waste Stream Tracking and Verification

The following documentation will be kept in relation to waste streams by VOA's contractor:

- Correspondence from the facility accepting the waste stream
- Waste profiles and all laboratory test results
- Waste characterization sampling, and results
- Manifests
- Bills of lading
- Weight tickets

## 11.4 Complaint Management

Complaints from citizens will be promptly reported to NYSDEC. Complaints will be addressed and outcomes will also be reported to NYSDEC in daily reports. Notices to NYSDEC will include the nature of the complaint, the party providing the complaint, and the actions taken to resolve any problems.

## 11.5 Deviations from the RAWP

Changes or modifications to the RAWP will be reported to the NYSDEC Project Manager and will be documented in daily reports and reported in the Remedial Action Report. The process to be followed if there are any significant deviations from the RAWP will include a modification request for approval of the change from NYSDEC prior to performing the change / modification noting the following:

- Reasons for deviating from the approved RAWP;
- Effect of the modification and or deviations on overall remedy; and
- Determination that the remedial action with the modification and or deviation(s) is protective of public health and the environment.

NYSDEC must approve the proposed change or modification.

## 11.6 Data Usability Summary Report

The primary objective of a Data Usability Summary Report (DUSR) is to determine whether or not data meets the site specific criteria for data quality and data use. The DUSR provides an evaluation of analytical data without third party data validation. The DUSR for post-remedial samples collected during implementation of this RAWP will be included in the FER.



### **11.7 Final Engineering Report**

A Final Engineering Report (FER) will be submitted to NYSDEC and NYSDOH following implementation of the remedial action defined in this RAWP. The FER will document that the remedial work required under this RAWP has been completed and has been performed in compliance with this plan. The FER will include:

- Information required by this RAWP;
- As-built drawings for constructed remedial elements, required certifications, manifests and other written and photographic documentation of remedial work performed under this remedy;
- Site Management Plan;
- Description of any changes in the remedial action from the elements provided in this RAWP and associated design documents;
- Tabular summary of all confirmation end point sampling results and all soil or material characterization results, QA/QC results for confirmation end-point sampling, and other sampling and chemical analysis performed as part of the remedial action and DUSR;
- Test results (such as geotechnical compaction tests) or other evidence demonstrating that remedial systems are functioning properly;
- Account of the source area removal excavation location and characteristics of contaminated material removed from the Site including a map showing these areas;
- Account of the disposal destination of contaminated material removed from the Site. Documentation associated with disposal of material will include transportation and disposal records, and letters approving receipt of the material.
- Account of the origin and required chemical quality testing for material imported onto the Site.
- Recorded Environmental Easement.
- Reports and supporting material will be submitted in digital form.
- Final Engineering Report certification.
- NYSDEC issues notice of completion after review of FER and SMP.

### **11.8 Agency Approvals**

Required permits or government approvals required for remedial construction will be obtained by VOA's contractors prior to the start of remedial construction. Approval of this RAWP by NYSDEC and NYSDOH does not constitute satisfaction of these requirements and will not be a substitute for required permits.

### **11.9 Schedule**

Implementation of the RAWP is scheduled to begin within 30 days of NYSDEC approval of this work plan. The work will be completed in accordance with the schedules provided by VOA's Contractor.

## 12.0 REFERENCES

- Remedial Investigation Report Volunteers of America 214 Lake Avenue Back Lot Site C828126 Rochester New York Bergmann Associates, December 2011; Revised May, 2012.
- RIR Addendum Additional Groundwater Sample Results Volunteers of America – Back Lot, Site (C828126) BCA Index # B 8-0688-05-04, 214 Lake Avenue Rochester, New York, December 28, 2012.
- 6 NYCRR Part 375 Environmental Remediation Programs Subparts 375-1 & 375-6. Division of Environmental Remediation. New York State Department of Environmental Conservation, Albany, N.Y. December 2006.
- Ambient Water Quality Standards and Guidance Values and Groundwater Effluent Limitations. Division of Water Technical and Operational Guidance Series (1.1.1). New York State of Environmental Conservation, Albany, N.Y. June 1998.
- DER-10 Technical Guidance for Site Investigation and Remediation. Division of Environmental Remediation. New York State Department of Environmental Conservation, Albany, N.Y. December 2002.
- DER-31 Technical Guidance for Site Investigation and Remediation. Division of Environmental Remediation. New York State Department of Environmental Conservation, Albany, N.Y. December 2002.
- Guidance for Conducting Remedial Investigations and Feasibility Studies Under CERCLA*. Interim Final. OSWER Directive 9355.3-01. EPA/540/G-89/004. Office of Emergency and Remedial Response. U.S. Environmental Protection Agency, Washington, D.C. October 1988
- Ruling. S.G. and Pivetz B.E., 2006. In-Situ Chemical Oxidation. U.S. EPA Engineering Issue. EPA 600-R-06-072.
- United States Environmental Protection Agency (USEPA), 1997. Analysis of Selected Enhancements for Soil Vapor Extraction. EPA-542-R-97-007
- USEPA, 1998. Field Applications of In Situ Remediation Technologies: Chemical Oxidation. EPA 542-R-98-008.

## **TABLES**

**Table 1 - Estimated Total Present Worth: Alternatives 1 through 5  
 Alternatives Analysis Report  
 Volunteers of America  
 214 Lake Avenue – Back Lot Site C828126  
 Rochester, New York**

Alternative	Description	Capital Cost	Annual Costs Projected For 30 Years	Total Present Worth
1	No Further Action	\$40,000	\$14,637	\$265,007
2	Excavation and off-Site disposal of contaminated media. Import clean soils.	\$24,238,000	\$0.00	\$24,238,000
3	Site-wide engineered cover system and limited excavation and off-site disposal for source area soil removal, with institutional and	\$1,244,672	\$4,718	\$1,317,191
4	Site-wide engineered cover system and soil vapor extraction system for source area soil in-situ treatment with institutional and engineering controls	\$1,090,319	\$9,168	\$1,231,246
5	Site-wide engineered cover system and chemical oxidation treatment for source area soils with institutional and engineering controls	\$1,101,782	\$4,718	\$1,174,301

TABLE 2  
 Ranking of Analysis for Alternatives  
 Alternatives Analysis Report  
 Volunteers of America of Western New York  
 214 Lake Avenue  
 Rochester, NY

Evaluation Criteria	Alternative 1 No Action	Alternative 2 Removal of All Contaminated Soils	Alternative 3 Site-wide Engineered Cap with Removal and off-Site Disposal of Source Area Soils	Alternative 4 Site-wide Engineered Cap with Soil Vapor Extraction for Treatment of Source Area Soils	Alternative 5 Site-wide Engineered Cap with Chemical Oxidation Treatment of Source Area Soils
Protection of Human Health and the Environment	1	5	4	2	3
Compliance with SCGs	1	5	4	2	3
Long-term Effectiveness and Permanence	1	5	4	2	3
Reduction of Toxicity, Mobility, or Volume	1	5	4	2	3
Short-term Effectiveness	1	2	5	3	4
Implementability	5	1	3	2	4
Cost	5	1	2	4	3
Land Use	1	5	4	2	3
Green and Sustainable	1	2	5	3	4
Totals	17	31	35	22	30

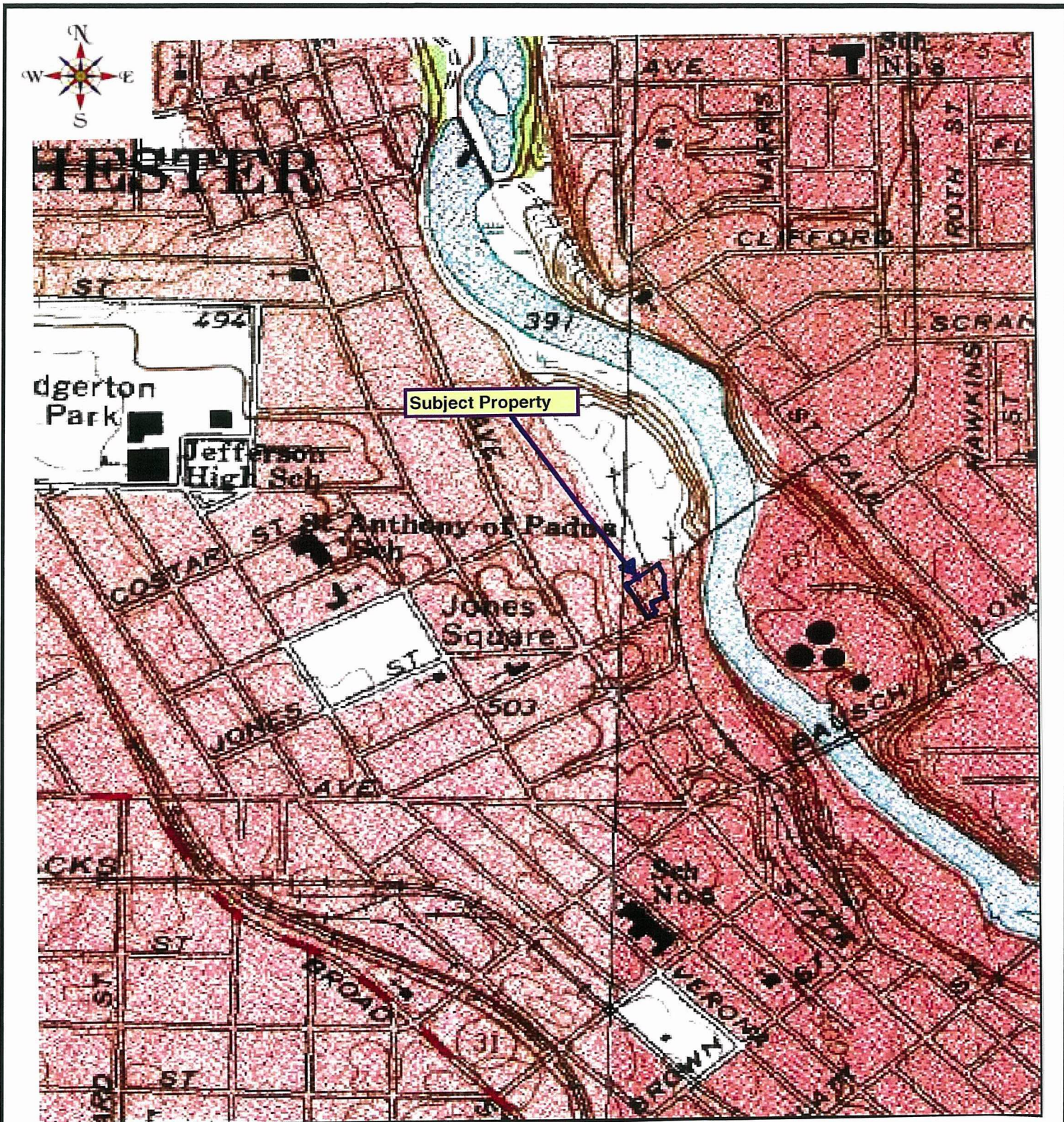
Ranking Scale: 5 equals the highest level that meets criteria and 1 equals lowest level

*Note: Alternative 3 has the highest rank based on the evaluation criteria and is the selected alternative for the remedy.*



## **FIGURES**





JM



Alternatives Analysis Report  
 Volunteers of America of Western New York  
 214 Lake Avenue

**Site Vicinity Map**

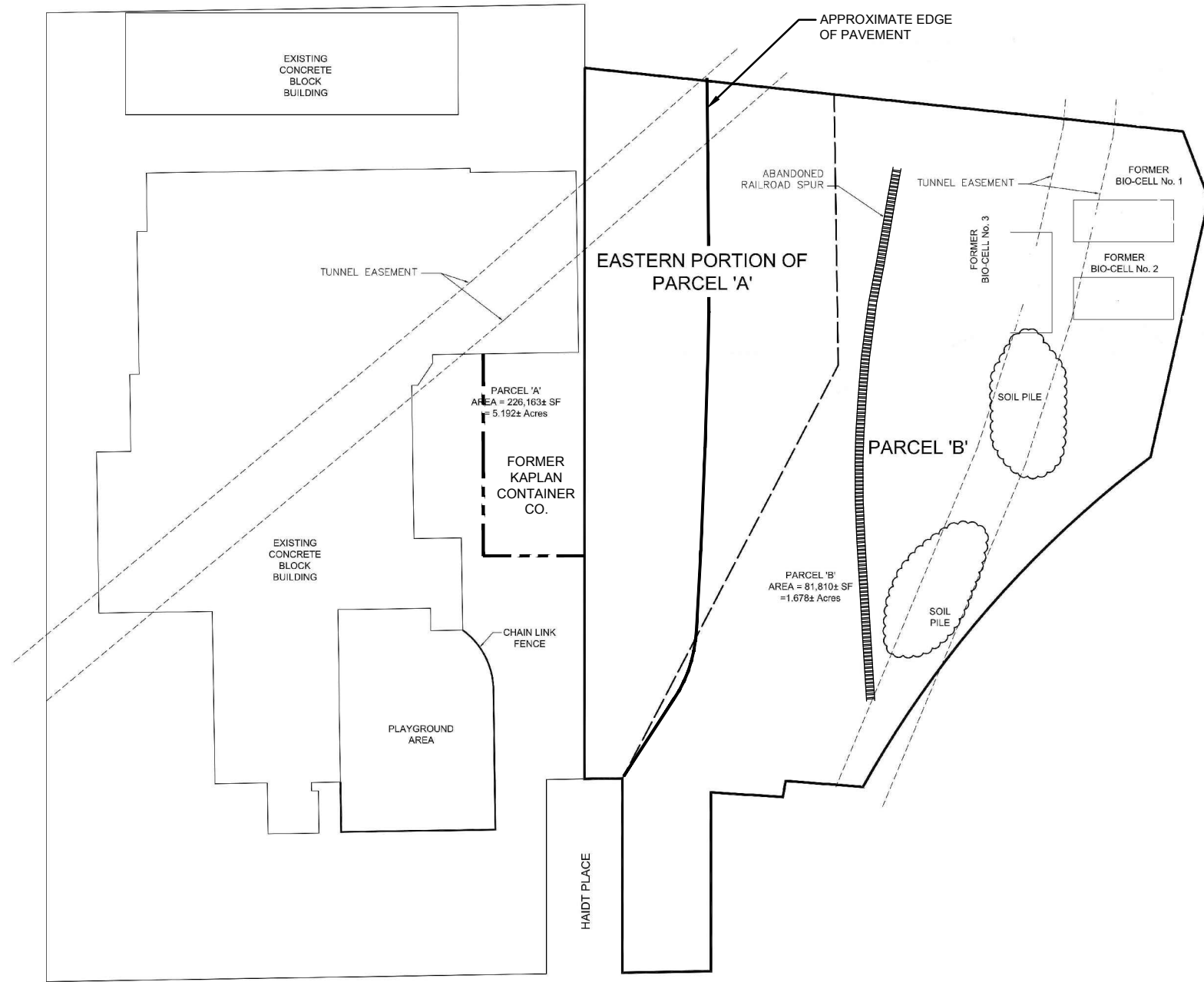
Bergmann Associates

Date  
 November-12

Figure  
 1

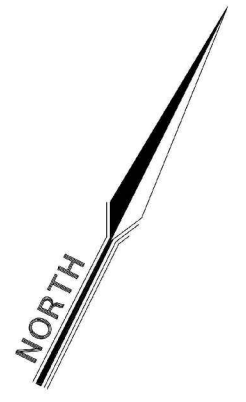
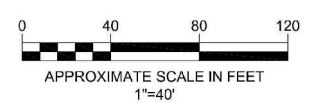


LAKE AVENUE (89' R.O.W.)



AMBROSE STREET (60' R.O.W.)

HAIDT PLACE



**LEGEND:**

- ABANDONED RAILROAD SPUR
- APPROXIMATE EDGE OF PAVEMENT
- EXISTING BUILDING
- PROJECT SITE BOUNDARY
- EAST BOUNDARY OF PARCEL 'A' AND WEST BOUNDARY OF PARCEL 'B'
- FORMER BIO-CELL
- SOIL PILE
- FORMER KAPLAN CONTAINER CO.

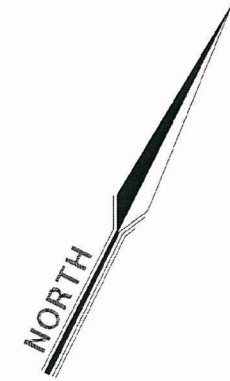
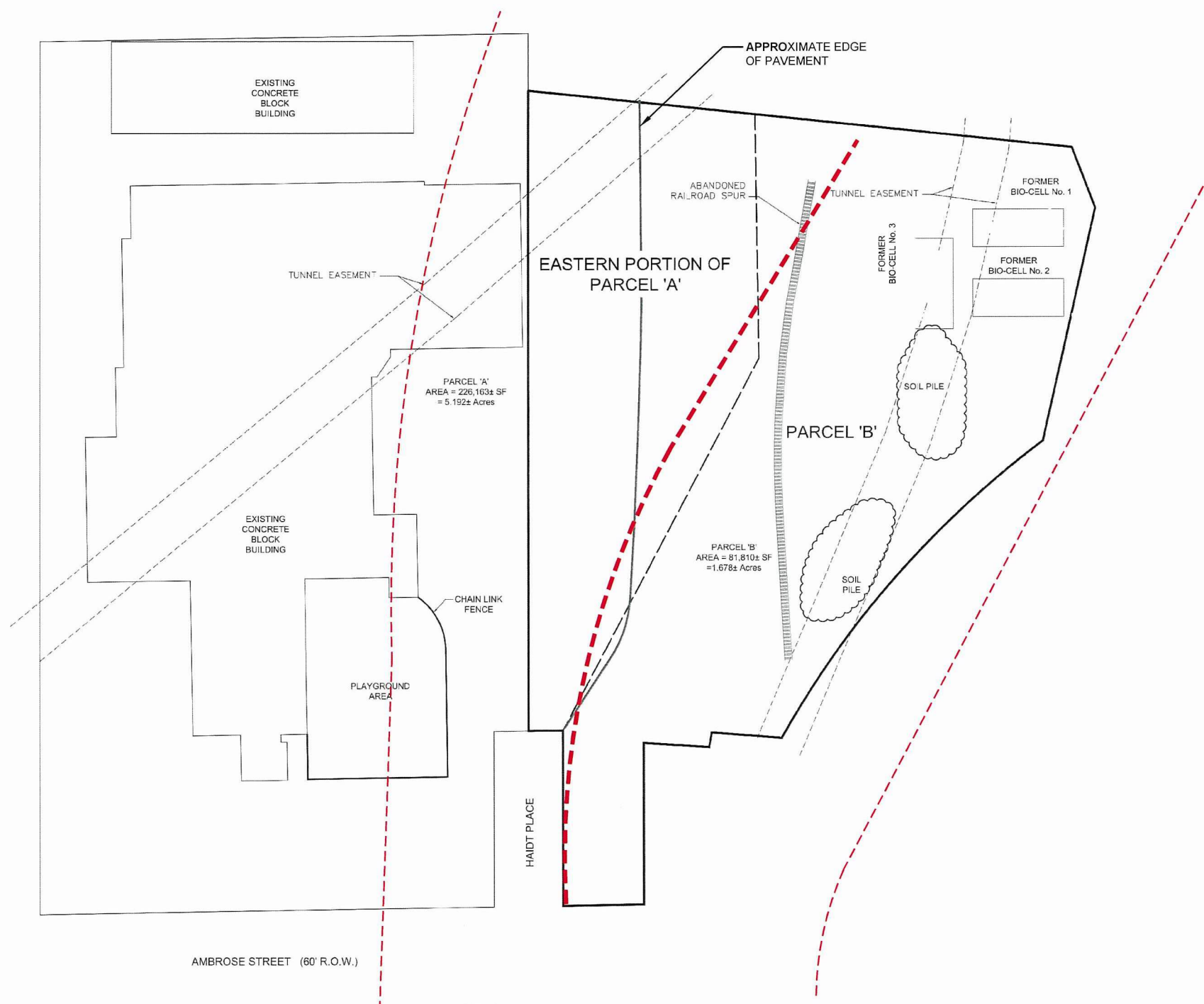
ALL LOCATIONS ARE APPLICABLE

**Bergmann**  
associates  
architects // engineers // planners










**SITE PLAN**  
FOR  
**ALTERNATIVES ANALYSIS REPORT**  
EASTERN PORTION OF PARCEL A AND PARCEL B  
214 LAKE AVENUE  
ROCHESTER, NEW YORK  
SEPTEMBER 22, 2009

**FIG. 2**

LAKE AVENUE (99' R.O.W.)

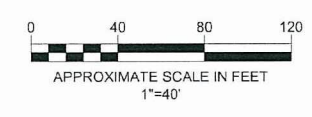


**LEGEND:**

-  ABANDONED RAILROAD SPUR
-  APPROXIMATE EDGE OF PAVEMENT
-  EXISTING BUILDING
-  PROJECT SITE BOUNDARY
-  EAST BOUNDARY OF PARCEL 'A' AND WEST BOUNDARY OF PARCEL 'B'
-  FORMER BIO-CELL
-  SOIL PILE
-  APPROXIMATE CENTERLINE OF FORMER RAVINE
-  APPROXIMATE EDGE OF FORMER RAVINE FROM 1875 CITY OF ROCHESTER NY MAP.

AMBROSE STREET (60' R.O.W.)

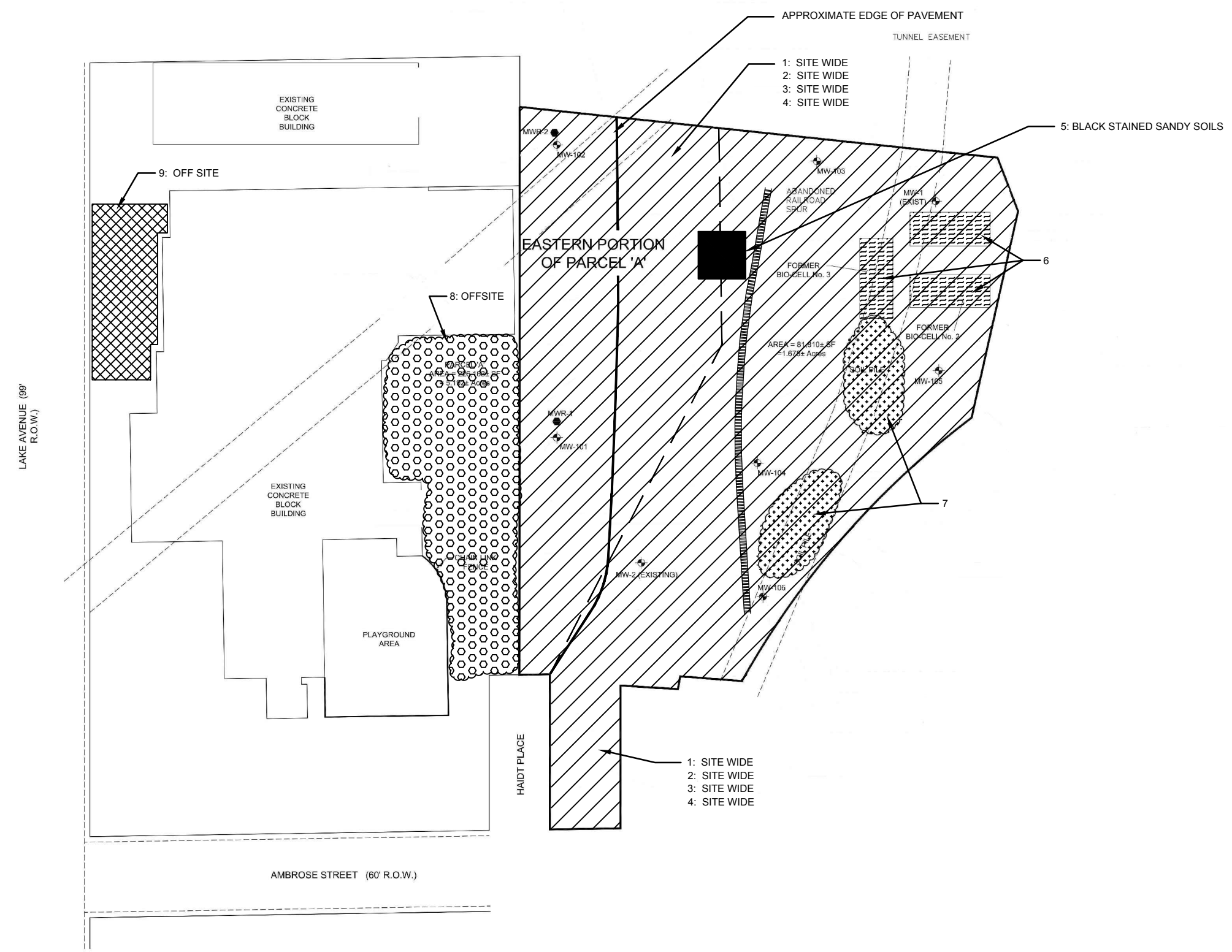
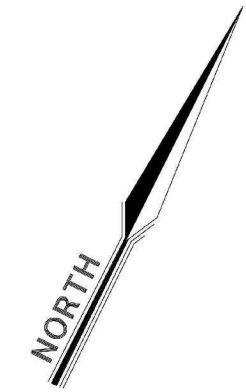
HADT PLACE



**Bergmann**  
associates  
architects // engineers // planners

APPROXIMATE LOCATION  
OF FORMER RAVINE  
FOR  
**ALTERNATIVES ANALYSIS REPORT**  
EASTERN PORTION OF PARCEL A AND PARCEL B  
214 LAKE AVENUE  
ROCHESTER, NEW YORK  
SEPTEMBER 22, 2009


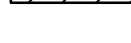


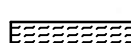
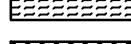

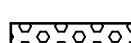
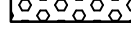
**FIG. 3**



**NOTES:**

1. ALL LOCATIONS ARE APPROXIMATE.
2. SEE REPORT TEXT (PAGE 25) FOR DESCRIPTION OF BLACK STAINED SANDY SOILS.

**LEGEND:**

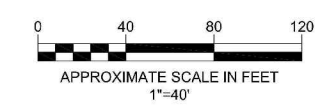
-  1: HISTORIC FILL SOILS (SITE WIDE)
-  2: FORMER COAL PILE STORAGE (SITE WIDE)
-  3: BURIED COAL TAR (SITE WIDE)
-  4: FORMER AUTOMOBILE PARKING AREA (SITE WIDE)
-  5: BLACK STAINED SANDY SOILS (LIMITED AREA)
-  6: SOILS IN FORMER BIO-CELLS
-  7: SOIL PILES
-  8: FORMER BARREL CLEANING AND BARREL RECONDITIONING OPERATIONS (OFF SITE)
-  9: FORMER GASOLINE SPILL (OFF SITE)



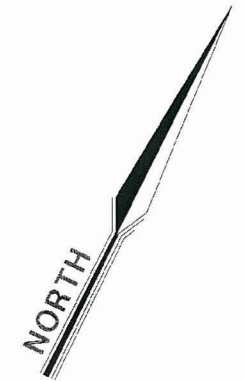
**LOCATIONS OF ENVIRONMENTAL CONDITIONS**

FOR  
**ALTERNATIVES ANALYSIS REPORT**  
 EASTERN PORTION OF PARCEL A AND PARCEL B  
 214 LAKE AVENUE  
 ROCHESTER, NEW YORK

EXISTING FEATURES, EXISTING TESTING AND SAMPLING INFORMATION WERE OBTAINED FROM MAPS PREPARED BY BERGMANN ASSOCIATES, PC, TITLED 'VOLUNTEERS OF AMERICA, WESTERN NEW YORK, NEW FACILITY, 214 LAKE AVENUE' BERGMANN PROJECT #3091.00, DATED FEB. 10, 1998.





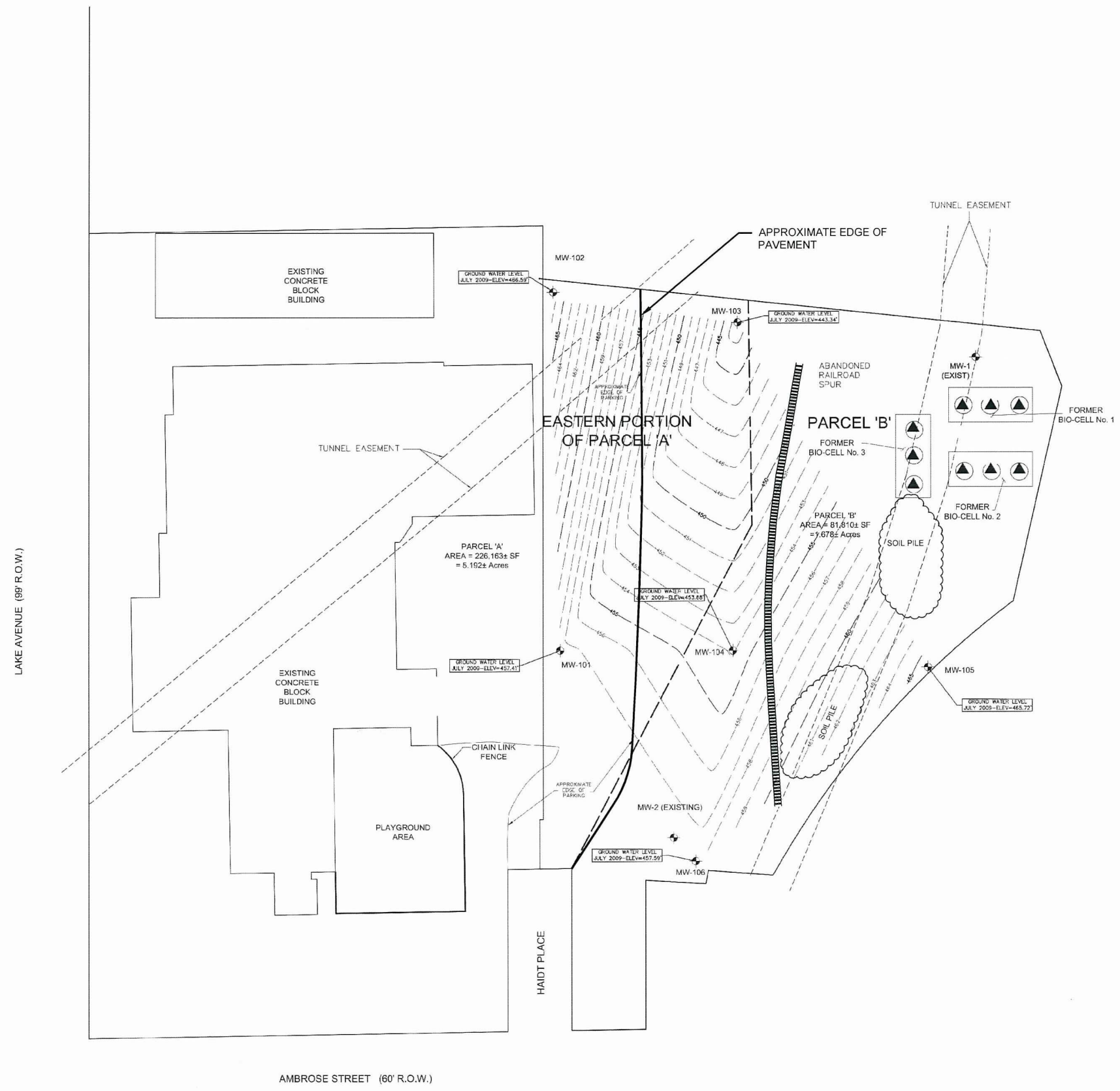


**NOTES:**

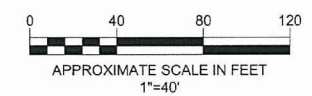
1. GROUNDWATER LEVEL INFORMATION COLLECTED FROM MONITOR WELLS ON JULY 27, 2009.

**LEGEND:**

- EXISTING BUILDING
- - - EAST BOUNDARY OF PARCEL 'A' AND WEST BOUNDARY OF PARCEL 'B'
- - - BIO-CELL
- ~ SOIL PILE
- ⊕ MONITOR WELL LOCATION
- ⊕ MW-101
- ▤ ABANDONED RAILROAD SPUR
- APPROXIMATE EDGE OF PAVEMENT



EXISTING FEATURES, EXISTING TESTING AND SAMPLING INFORMATION WERE OBTAINED FROM MAPS PREPARED BY BERGMANN ASSOCIATES, PC, TITLED 'VOLUNTEERS OF AMERICA, WESTERN NEW YORK, NEW FACILITY, 214 LAKE AVENUE' BERGMANN PROJECT #3091.00, DATED FEB. 10, 1998.



**Bergmann**  
associates  
architects // engineers // planners

GROUND WATER CONTOUR MAP  
JULY 27, 2009  
FOR  
**ALTERNATIVES ANALYSIS REPORT**  
EASTERN PORTION OF PARCEL A AND PARCEL B  
214 LAKE AVENUE  
ROCHESTER, NEW YORK  
DECEMBER 15, 2009

**FIG. 5**

**ALTERNATIVES ANALYSIS REPORT**

Volunteers of America of Western, New York

**Volunteers of America**

214 Lake Avenue Rochester, New York

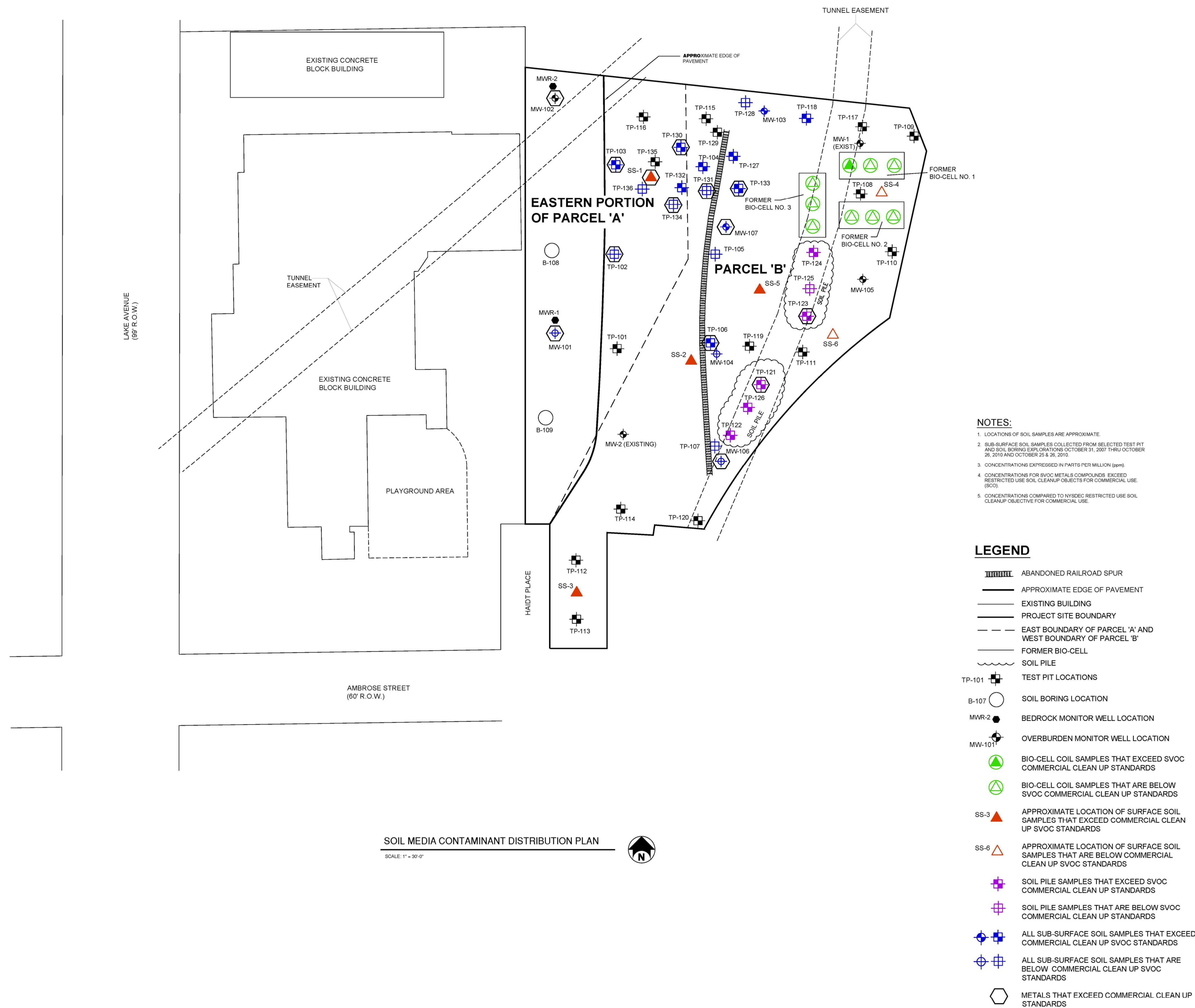


28 East Main Street  
200 First Federal Plaza  
Rochester, New York 14614-1909

office: 585.232.5135  
fax: 585.232.4652

www.bergmannpc.com

REVISIONS			
NO.	DATE	DESCRIPTION	REV.



**SVOC AND METAL SOIL SAMPLE LOCATIONS THAT EXCEED SOIL CLEANUP OBJECTIVES FOR COMMERCIAL USE**

NOTE:  
Unauthorized alteration or addition to this drawing is a violation of the New York State Education Law Article 145, Section 7209.

Project Manager: **G. FLISNIK**  
Designed by: **S. GONDO**  
Checked by: **M. TRINLEY**  
Date Issued: **MARCH 2012**  
Scale: **AS SHOWN**  
Title: **SOIL SAMPLE**

**FIG. 6**



# ALTERNATIVES ANALYSIS REPORT

Volunteers of America of Western, New York

## Volunteers of America

214 Lake Avenue  
Rochester, New York

**Bergmann**  
associates  
architects // engineers // planners

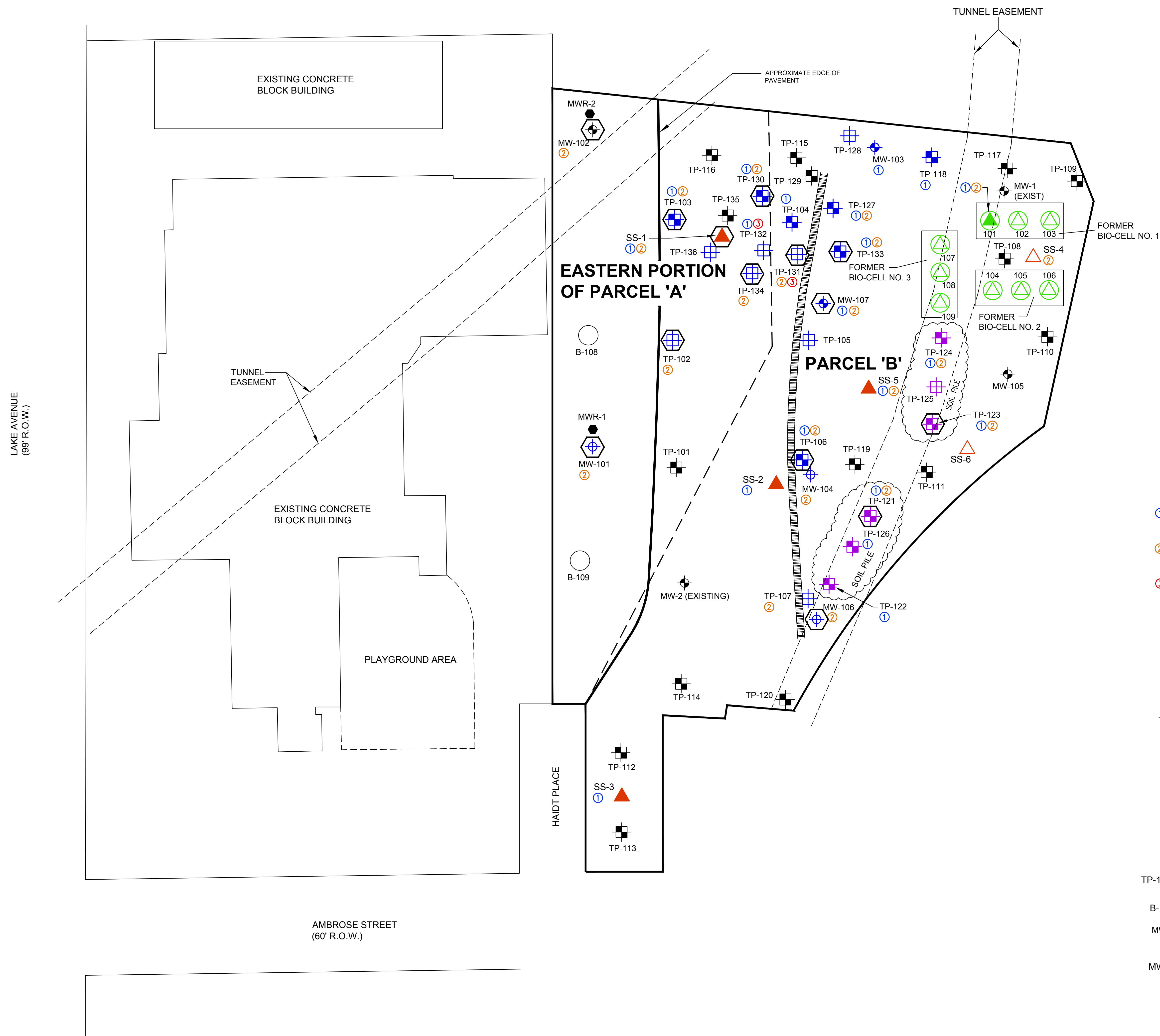
28 East Main Street  
200 First Federal Plaza  
Rochester, New York 14614-1909

office: 585.232.5135

fax: 585.232.4652

www.bergmannpc.com

REVISIONS			
NO.	DATE	DESCRIPTION	REV. CK'D



### NOTES:

- 1) LOCATIONS OF SOIL SAMPLES ARE APPROXIMATE.
- 2) SUB-SURFACE SOIL SAMPLES COLLECTED FROM SELECTED TEST PIT AND SOIL BORING EXPLORATIONS OCTOBER 31, 2007 THRU OCTOBER 26, 2010 AND OCTOBER 25 & 26, 2010.
- 3) CONCENTRATIONS EXPRESSED IN PARTS PER MILLION (ppm).
- 4) CONCENTRATIONS FOR SVOC METALS COMPOUNDS EXCEED RESTRICTED USE SOIL CLEANUP OBJECTS FOR COMMERCIAL USE (SCO).
- 5) CONCENTRATIONS COMPARED TO NYSDEC RESTRICTED USE SOIL CLEANUP OBJECTIVE FOR COMMERCIAL USE.

### KEY

(LOCATIONS THAT EXCEED PROTECTION OF GROUNDWATER VALUES)

- ① SOIL SAMPLE LOCATION EXCEEDS PROTECTION OF GROUNDWATER VALUES FOR ONE OR MORE SVOC
- ② SOIL SAMPLE LOCATION EXCEEDS PROTECTION OF GROUNDWATER VALUES FOR ONE OR MORE METALS
- ③ SOIL SAMPLE LOCATION EXCEEDS PROTECTION OF GROUNDWATER VALUES FOR ONE OR MORE VOC

### LEGEND

- ▬ ABANDONED RAILROAD SPUR
- APPROXIMATE EDGE OF PAVEMENT
- ▭ EXISTING BUILDING
- ▭ PROJECT SITE BOUNDARY
- EAST BOUNDARY OF PARCEL 'A' AND WEST BOUNDARY OF PARCEL 'B'
- ▭ FORMER BIO-CELL
- ⌋ SOIL PILE
- TP-101 ■ TEST PIT LOCATIONS
- B-107 ○ SOIL BORING LOCATION
- MWR-2 ● BEDROCK MONITOR WELL LOCATION
- MW-101 ⬆ OVERBURDEN MONITOR WELL LOCATION
- ▲ BIO-CELL COIL SAMPLES THAT EXCEED SVOC COMMERCIAL CLEAN UP STANDARDS
- △ BIO-CELL COIL SAMPLES THAT ARE BELOW SVOC COMMERCIAL CLEAN UP STANDARDS
- SS-3 ▲ APPROXIMATE LOCATION OF SURFACE SOIL SAMPLES THAT EXCEED COMMERCIAL CLEAN UP SVOC STANDARDS
- SS-6 △ APPROXIMATE LOCATION OF SURFACE SOIL SAMPLES THAT ARE BELOW COMMERCIAL CLEAN UP SVOC STANDARDS
- ⊕ SOIL PILE SAMPLES THAT EXCEED SVOC COMMERCIAL CLEAN UP STANDARDS
- ⊖ SOIL PILE SAMPLES THAT ARE BELOW SVOC COMMERCIAL CLEAN UP STANDARDS
- ⊕ ALL SUB-SURFACE SOIL SAMPLES THAT EXCEED COMMERCIAL CLEAN UP SVOC STANDARDS
- ⊖ ALL SUB-SURFACE SOIL SAMPLES THAT ARE BELOW COMMERCIAL CLEAN UP SVOC STANDARDS.
- ⊖ METALS THAT EXCEED COMMERCIAL CLEANUP STANDARDS.

### SOIL MEDIA CONTAMINANT DISTRIBUTION PLAN

SCALE: 1" = 30'-0"



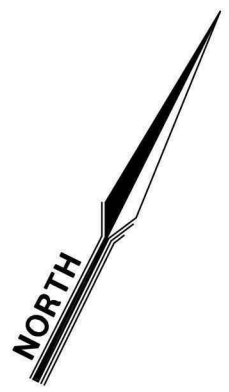
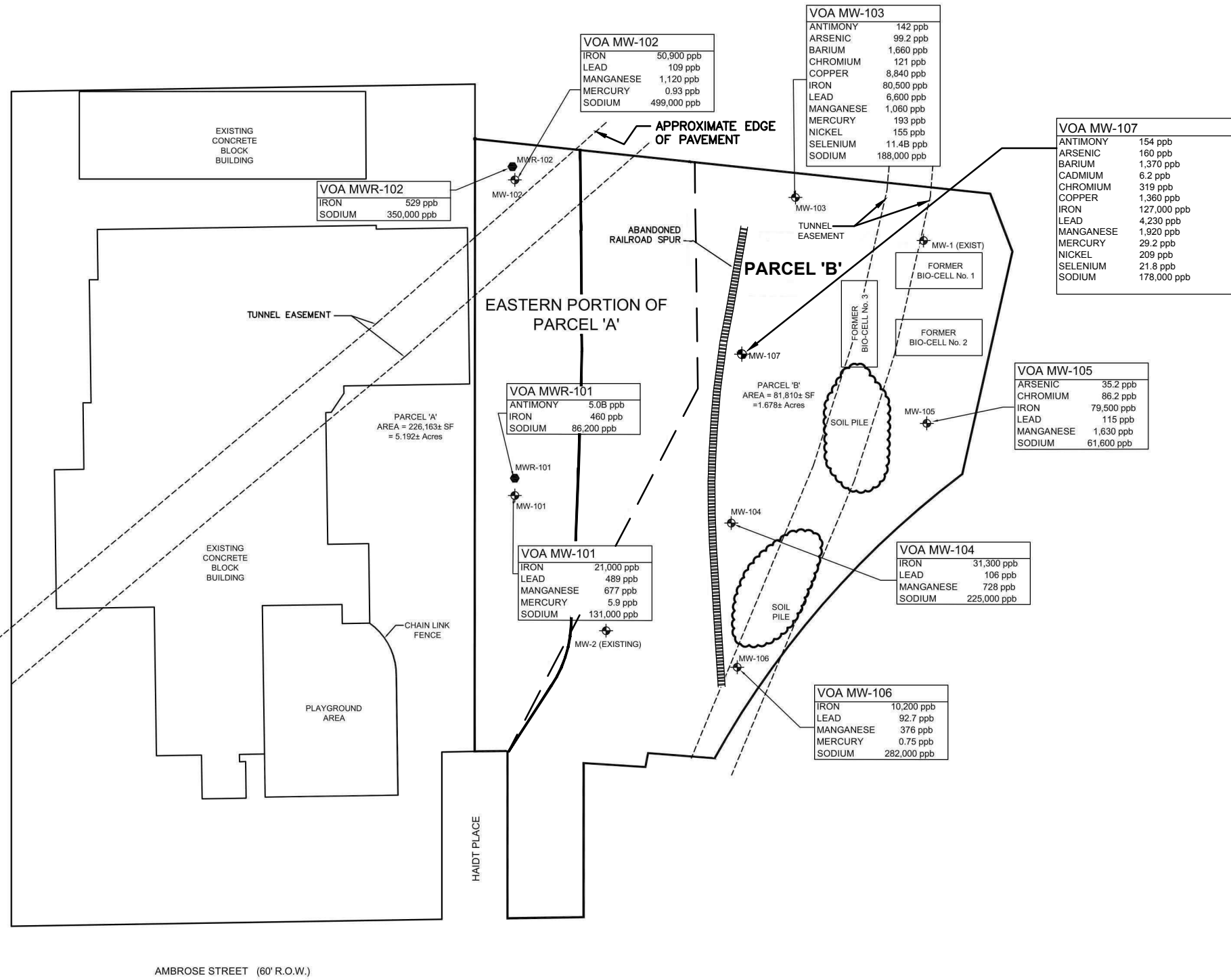
### SOIL SAMPLE LOCATIONS THAT EXCEED PROTECTION OF GROUNDWATER VALUES

NOTE:  
Unauthorized alteration or addition to this drawing is a violation of the New York State Education Law Article 145, Section 7209.

Project Manager: **G. FUSNIK**  
Designed by: **S. DEMEO**  
Drawn by: **M. THOLEY, C. WOOD**  
Checked by:  
Date Issued: **10/12/10**  
Scale: **1" = 30'**

Drawing Number: **FIG. 7**

LAKE AVENUE (89' R.O.W.)



**NOTES:**

1. LOCATIONS OF SUBSURFACE LOCATIONS ARE APPROXIMATE.
2. SAMPLES COLLECTED FROM MONITORING WELLS ON OCTOBER 30 & OCTOBER 31, 2008. SAMPLE FROM MW-107 COLLECTED ON NOVEMBER 4, 2010
3. CONCENTRATIONS EXPRESSED IN PARTS PER BILLION (ppb).
4. CONCENTRATIONS FOR METALS EXCEED NEW YORK STATE GROUNDWATER STANDARDS.

**LEGEND:**

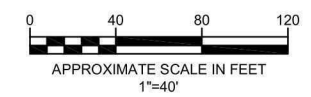
- MWR-102 BEDROCK MONITORING WELL
- ⊕ MW-102 OVERBURDEN MONITORING WELL
- EXISTING BUILDING
- PROJECT SITE BOUNDARY
- - - EAST BOUNDARY OF PARCEL 'A' AND WEST BOUNDARY OF PARCEL 'B'
- FORMER BIO-CELL
- ~ SOIL PILE
- ||||| ABANDONED RAILROAD SPUR
- APPROXIMATE EDGE OF PAVEMENT



**GROUNDWATER CONTAMINANT DISTRIBUTION PLAN  
 METALS**

**OCTOBER 30 AND 31, 2008  
 ALTERNATIVES ANALYSIS REPORT  
 EASTERN PORTION OF PARCEL A AND PARCEL B  
 214 LAKE AVENUE  
 ROCHESTER, NEW YORK  
 DECEMBER 22, 2010**

EXISTING FEATURES, EXISTING TESTING AND SAMPLING INFORMATION WERE OBTAINED FROM MAPS PREPARED BY BERGMANN ASSOCIATES, PC, TITLED "VOLUNTEERS OF AMERICA, WESTERN NEW YORK, NEW FACILITY, 214 LAKE AVENUE" BERGMANN PROJECT #3091.00, DATED FEB. 10, 1998.



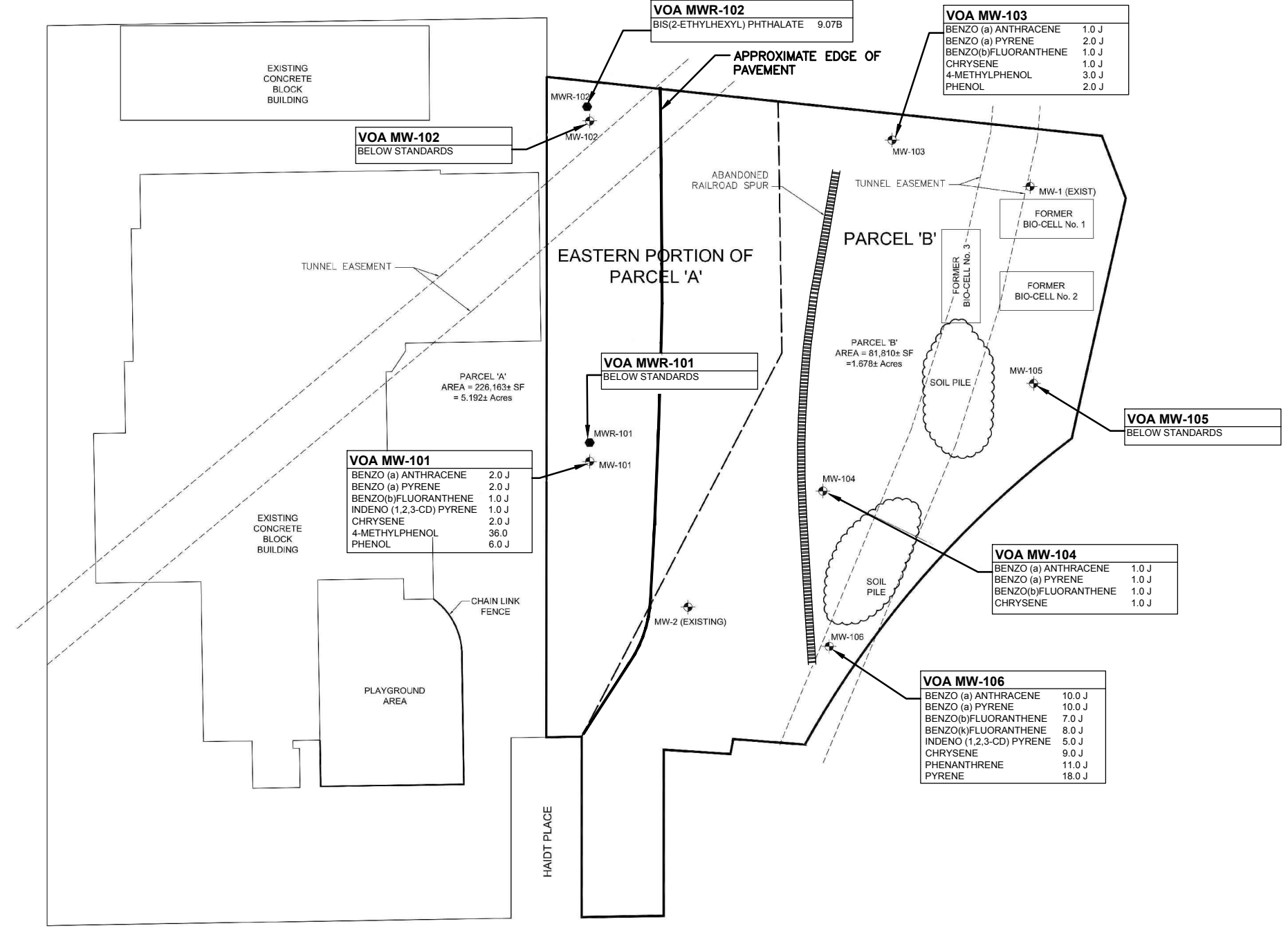
**FIG. 8**



LAKE AVENUE (99' R.O.W.)

AMBROSE STREET (60' R.O.W.)

HAIDT PLACE



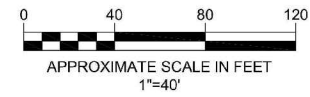
- NOTES:**
1. LOCATIONS OF SUBSURFACE LOCATIONS ARE APPROXIMATE.
  2. SAMPLES COLLECTED FROM MONITORING WELLS ON OCTOBER 30 AND 31, 2008.
  3. CONCENTRATIONS EXPRESSED IN PARTS PER BILLION (ppb).
  4. CONCENTRATIONS FOR SVOC COMPOUNDS EXCEED NEW YORK STATE CLASS GA GROUNDWATER STANDARDS.

- LEGEND:**
- MWR-102 BEDROCK MONITORING WELL
  - ⊕ MW-102 OVERBURDEN MONITORING WELL
  - EXISTING BUILDING
  - PROJECT SITE BOUNDARY
  - - - EAST BOUNDARY OF PARCEL 'A' AND WEST BOUNDARY OF PARCEL 'B'
  - FORMER BIO-CELL
  - ~ SOIL PILE
  - ||||| ABANDONED RAILROAD SPUR
  - APPROXIMATE EDGE OF PAVEMENT

  
**Bergmann**  
 associates  
 architects // engineers // planners

GROUNDWATER CONTAMINANT DISTRIBUTION PLAN  
 SEMI-VOLATILE ORGANIC COMPOUNDS  
 OCTOBER 30 and 31, 2008  
 FOR  
**ALTERNATIVES ANALYSIS REPORT**  
 EASTERN PORTION OF PARCEL A AND PARCEL B  
 214 LAKE AVENUE  
 ROCHESTER, NEW YORK  
 SEPTEMBER 22, 2009

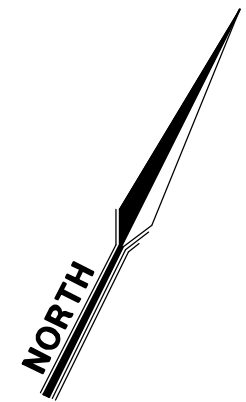
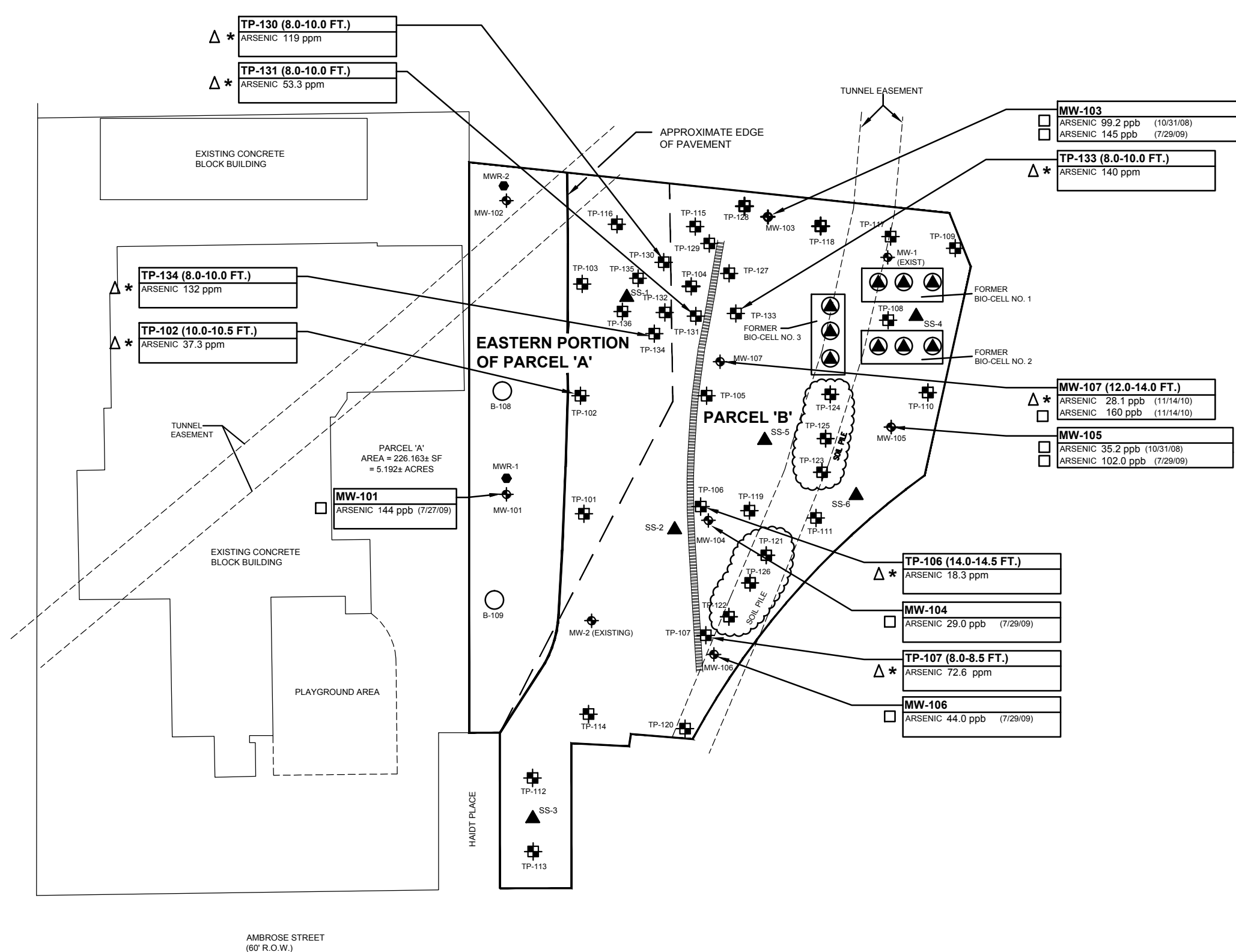
EXISTING FEATURES, EXISTING TESTING AND SAMPLING INFORMATION WERE OBTAINED FROM MAPS PREPARED BY BERGMANN ASSOCIATES, P.C. TITLED "VOLUNTEERS OF AMERICA, WESTERN NEW YORK, NEW FACILITY, 214 LAKE AVENUE" BERGMANN PROJECT #3091.00, DATED FEB. 10, 1998.



**FIG. 9**



LAKE AVENUE  
(60' R.O.W.)



**NOTES:**

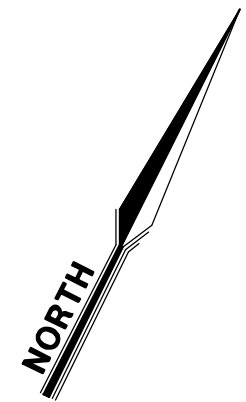
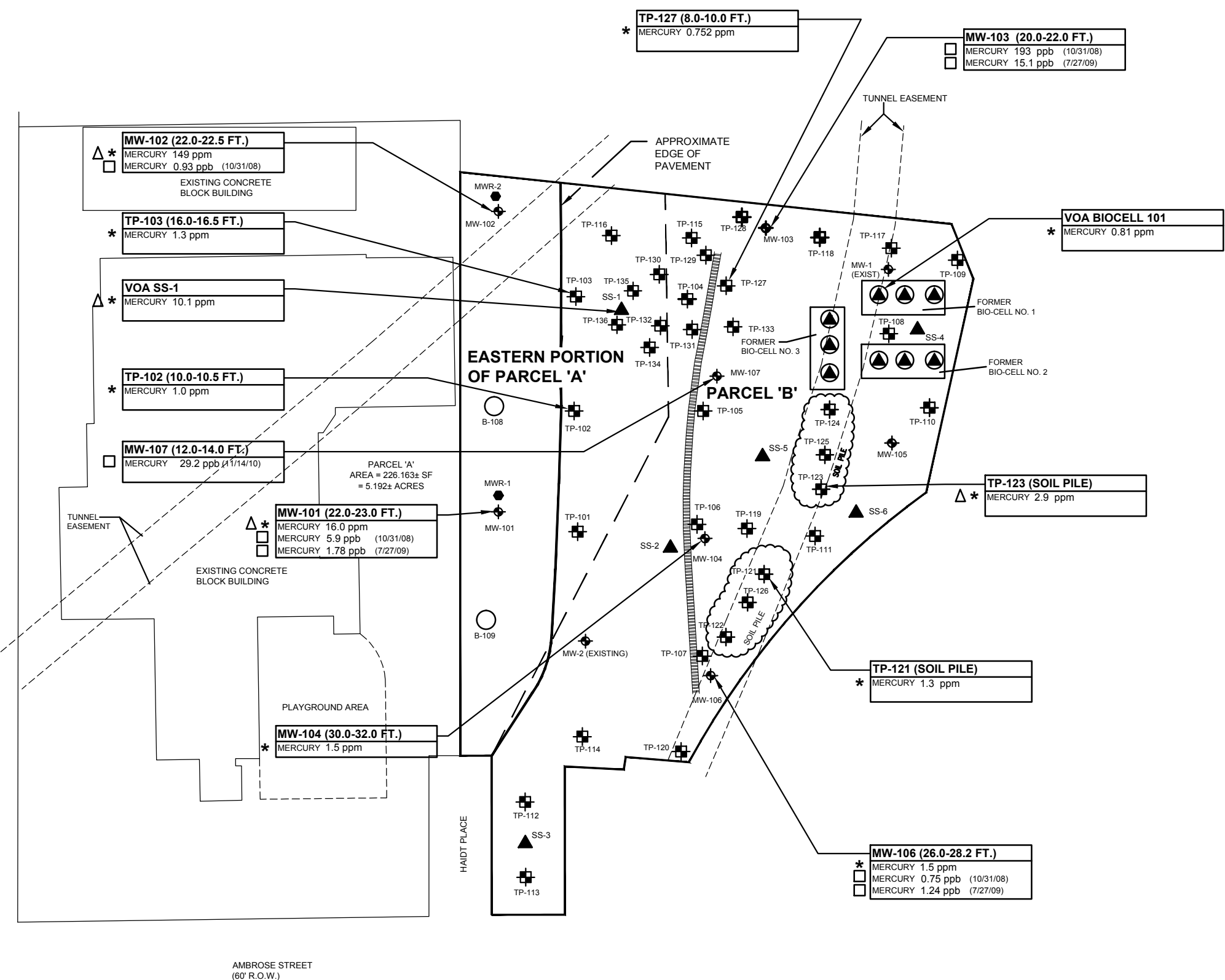
1. LOCATIONS OF SUBSURFACE LOCATIONS ARE APPROXIMATE.
2. SUB-SURFACE SOIL SAMPLES COLLECTED FROM SELECTED TEST PIT AND SOIL BORING EXPLORATIONS OCTOBER 31, 2007 THRU OCTOBER 26, 2010.
3. ARSENIC WAS DETECTED IN SEVERAL SOIL AND GROUNDWATER SAMPLES WITH LOWER CONCENTRATIONS. SEE TABLES 5 AND 7 IN THE RI REPORT.

**LEGEND**

- INDICATES DETECTION OF ARSENIC IN GROUNDWATER SAMPLE IN ppb THAT EXCEEDS PART 703.5 GROUNDWATER STANDARDS
- △ CONCENTRATIONS OF ARSENIC DETECTED IN SOIL SAMPLE THAT EXCEED COMMERCIAL SOIL CLEANUP OBJECTIVES.
- \* CONCENTRATIONS OF ARSENIC DETECTED IN SOIL SAMPLE THAT EXCEEDS PROTECTION OF GROUNDWATER CLEANUP OBJECTIVES.
- EXISTING BUILDING
- PROJECT SITE BOUNDARY
- EAST BOUNDARY OF PARCEL 'A' AND WEST BOUNDARY OF PARCEL 'B'
- FORMER BIO-CELL
- SOIL PILE
- TP-101 + TEST PIT LOCATIONS
- B-107 ○ SOIL BORING LOCATION
- MW-101 ● MONITOR WELL LOCATION
- BIO-CELL COIL SAMPLE LOCATION
- SS-# ▲ APPROXIMATE LOCATION OF SURFACE SOIL SAMPLE
- ABANDONED RAILROAD SPUR
- APPROXIMATE EDGE OF PAVEMENT

**DISTRIBUTION OF ARSENIC IN  
SOIL AND GROUNDWATER SAMPLES**  
FOR  
**ALTERNATIVES ANALYSIS REPORT**  
EASTERN PORTION OF PARCEL A AND PARCEL B  
214 LAKE AVENUE  
ROCHESTER, NEW YORK

LAKE AVENUE  
(60' R.O.W.)



**NOTES:**

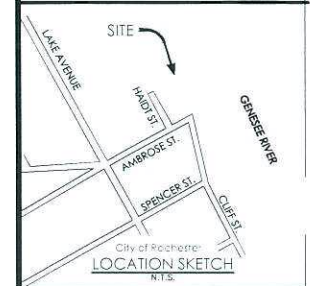
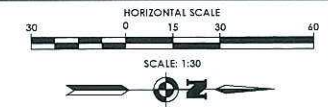
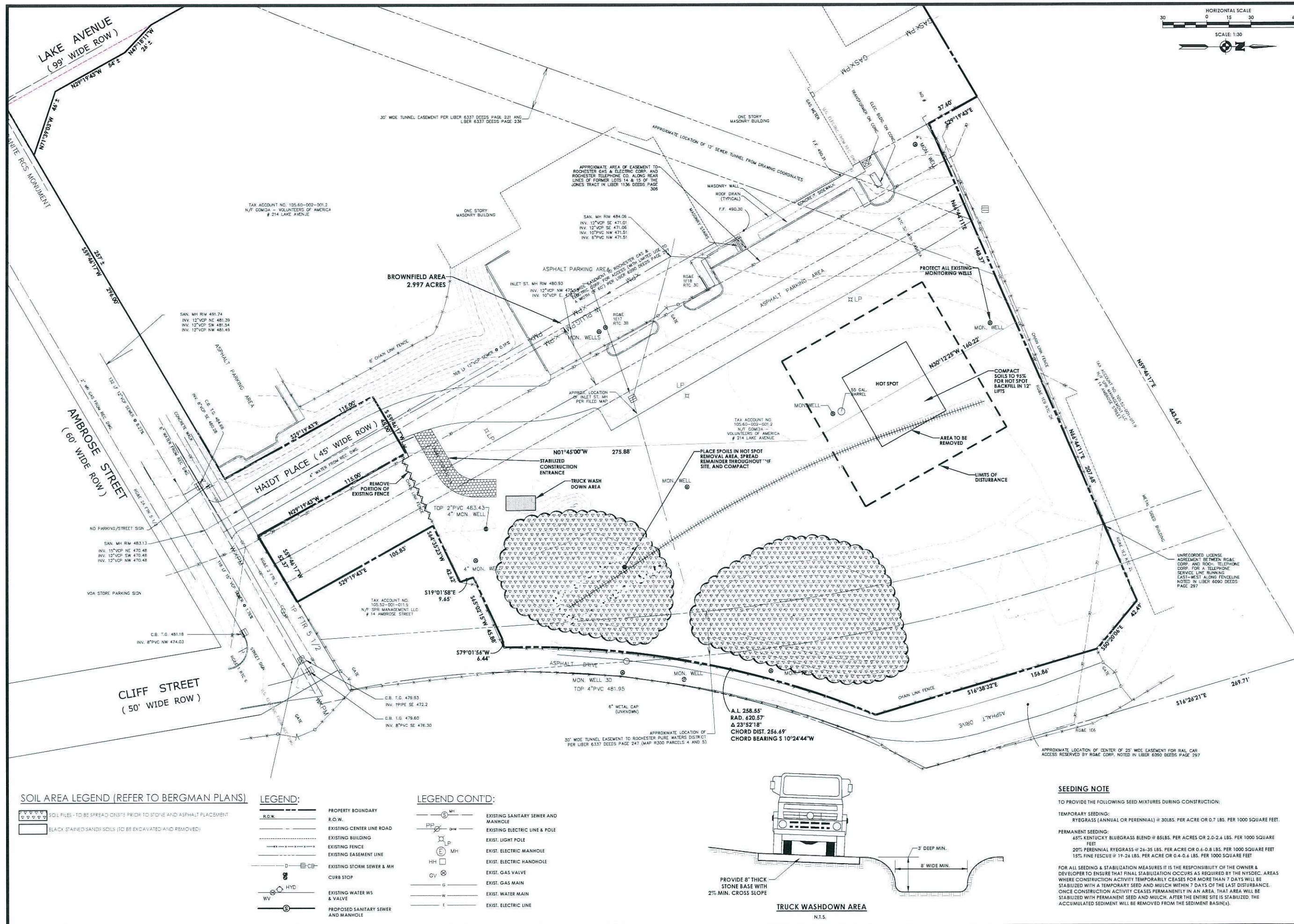
1. LOCATIONS OF SUBSURFACE LOCATIONS ARE APPROXIMATE.
2. SUB-SURFACE SOIL SAMPLES COLLECTED FROM SELECTED TEST PIT AND SOIL BORING EXPLORATIONS OCTOBER 31, 2007 THRU OCTOBER 26, 2010.
3. MERCURY WAS DETECTED IN SEVERAL SOIL AND GROUNDWATER SAMPLES WITH LOWER CONCENTRATIONS. SEE TABLES 5 AND 7 IN THE RI REPORT..

**LEGEND**

- INDICATES DETECTION OF MERCURY IN GROUNDWATER SAMPLE IN ppb THAT EXCEEDS PART 703.5 GROUNDWATER STANDARDS.
- △ CONCENTRATIONS OF MERCURY DETECTED IN SOIL SAMPLE THAT EXCEEDS COMMERCIAL SOIL CLEANUP OBJECTIVES.
- \* CONCENTRATIONS OF MERCURY DETECTED IN SOIL SAMPLE THAT EXCEEDS PROTECTION OF GROUNDWATER CLEANUP OBJECTIVES.
- EXISTING BUILDING
- PROJECT SITE BOUNDARY
- EAST BOUNDARY OF PARCEL 'A' AND WEST BOUNDARY OF PARCEL 'B'
- FORMER BIO-CELL
- ~ SOIL PILE
- ABANDONED RAILROAD SPUR
- APPROXIMATE EDGE OF PAVEMENT
- TP-101 ⊕ TEST PIT LOCATIONS
- B-107 ○ SOIL BORING LOCATION
- MW-101 ⊕ MONITOR WELL LOCATION
- ⊕ BIO-CELL COIL SAMPLE LOCATION
- SS-# ▲ APPROXIMATE LOCATION OF SURFACE SOIL SAMPLE

**DISTRIBUTION OF MERCURY IN SOIL AND GROUNDWATER SAMPLES**  
FOR  
**ALTERNATIVES ANALYSIS REPORT**  
EASTERN PORTION OF PARCEL A AND PARCEL B  
214 LAKE AVENUE  
ROCHESTER, NEW YORK





Client:  
**Volunteers of America**  
 214 Lake Avenue  
 Rochester, NY 14608

**PASSERO ASSOCIATES**  
 245 West Main Street, Suite 100  
 Rochester, New York 14614  
 (585) 325-1000  
 Fax: (585) 325-1047  
 Principal in Charge: **John F. Caruso, P.E.**  
 Project Manager: **Jess D. Sudol, P.E.**  
 Designer: **Carole G. Harvey**

Revisions			
No.	Date	By	Description
1			

UNAUTHORIZED ALTERATIONS OR ADDITIONS TO THIS DRAWING IS IN VIOLATION OF STATE EDUCATION LAW ARTICLE 145 SECTION 209 AND ARTICLE 147 SECTION 7307. THESE PLANS ARE COPYRIGHT PROTECTED.

**EXISTING CONDITIONS / DEMOLITION PLAN**

**VOA Cobblestone at Lake**

Town/City: Rochester  
 County: Monroe State: New York

Project No:  
**20121554.0004**

Drawing No: **C 101** Sheet No: **1**

Scale: **1"=30'**

Date: **NOVEMBER 2015**

**SOIL AREA LEGEND (REFER TO BERGMAN PLANS)**

- SOIL PILES - TO BE SPREAD ON SITE PRIOR TO STONE AND ASPHALT PLACEMENT
- BLACK STAINED SANDS SOILS (TO BE EXCAVATED AND REMOVED)

**LEGEND:**

- PROPERTY BOUNDARY
- R.O.W.
- EXISTING CENTER LINE ROAD
- EXISTING BUILDING
- EXISTING FENCE
- EXISTING EASEMENT LINE
- EXISTING STORM SEWER & MH
- CURB STOP
- EXISTING WATER WS & VALVE
- PROPOSED SANITARY SEWER AND MANHOLE

**LEGEND CONT'D:**

- EXISTING SANITARY SEWER AND MANHOLE
- EXISTING ELECTRIC LINE & POLE
- EXIST. LIGHT POLE
- EXIST. ELECTRIC MANHOLE
- EXIST. ELECTRIC HANDHOLE
- EXIST. GAS VALVE
- EXIST. GAS MAIN
- EXIST. WATER MAIN
- EXIST. ELECTRIC LINE

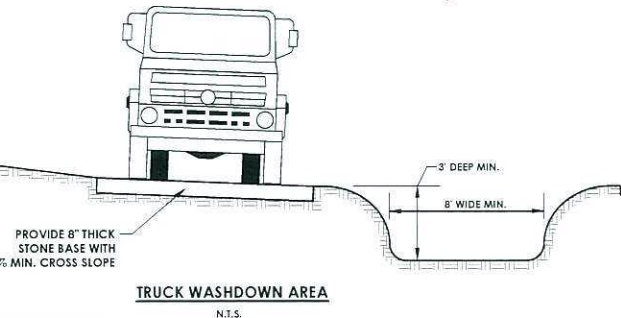
**SEEDING NOTE**

TO PROVIDE THE FOLLOWING SEED MIXTURES DURING CONSTRUCTION:

TEMPORARY SEEDING:  
 RYEGRASS (ANNUAL OR PERENNIAL) @ 30LBS. PER ACRE OR 0.7 LBS. PER 1000 SQUARE FEET.

PERMANENT SEEDING:  
 65% KENTUCKY BLUEGRASS BLEND @ 85LBS. PER ACRE OR 2.0-2.6 LBS. PER 1000 SQUARE FEET  
 20% PERENNIAL RYEGRASS @ 28-35 LBS. PER ACRE OR 0.4-0.8 LBS. PER 1000 SQUARE FEET  
 15% FINE FESCUE @ 19-24 LBS. PER ACRE OR 0.4-0.6 LBS. PER 1000 SQUARE FEET

FOR ALL SEEDING & STABILIZATION MEASURES IT IS THE RESPONSIBILITY OF THE OWNER & DEVELOPER TO ENSURE THAT FINAL STABILIZATION OCCURS AS REQUIRED BY THE NYSDEC. AREAS WHERE CONSTRUCTION ACTIVITY TEMPORARILY CEASES FOR MORE THAN 7 DAYS WILL BE STABILIZED WITH A TEMPORARY SEED AND MULCH WITHIN 7 DAYS OF THE LAST DISTURBANCE. ONCE CONSTRUCTION ACTIVITY CEASES PERMANENTLY IN AN AREA, THAT AREA WILL BE STABILIZED WITH PERMANENT SEED AND MULCH. AFTER THE ENTIRE SITE IS STABILIZED, THE ACCUMULATED SEDIMENT WILL BE REMOVED FROM THE SEDIMENT BASIN(S).



**Figure 12 – Site Plan with Hot Spot Excavation Area**



**LEGEND:**

- R.O.W.
- EXISTING CENTER LINE ROAD
- EXISTING BUILDING
- EXISTING EASEMENT LINE
- PROPOSED EASEMENT LINE

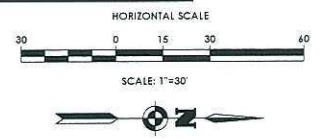
  

- PROPOSED SIGN
- PROPOSED LIGHT
- PROPOSED STORM SEWER, INLET, MH, CB & END SECTION
- EXISTING STORM SEWER & MH
- PROPOSED WATER WS W/ HYDRANT & VALVE
- CURB STOP
- EXISTING WATER WS & VALVE
- PROPOSED SANITARY SEWER AND MANHOLE
- EXISTING SANITARY SEWER AND MANHOLE
- EXISTING ELECTRIC LINE & POLE
- EXIST. LIGHT POLE
- EXIST. ELECTRIC MANHOLE
- EXIST. ELECTRIC HANDHOLE
- EXIST. GAS VALVE
- EXIST. GAS MAIN
- EXIST. WATER MAIN
- EXIST. ELECTRIC LINE
- PROPOSED UNDERGROUND ELECTRIC

- GENERAL NOTES:**
- CONTRACTOR IS RESPONSIBLE TO CALL CENTRAL STAKE-OUT @ 1-800-962-7962 PRIOR TO BEGINNING DEMOLITION.
  - CONTRACTOR TO KEEP ROAD CLEAR & CLEAN DURING DEMOLITION AND SHALL COORDINATE WITH THE CITY OF ROCHESTER AND THE OWNER.
  - CONTRACTOR IS RESPONSIBLE TO REMOVE NON-CONCRETE/MASONRY MATERIALS FROM THE PROJECT SITE.
  - CONTRACTOR IS RESPONSIBLE TO PROTECT ALL UTILITIES AND CONDUITS ON SITE DURING CONSTRUCTION.
  - ANY EXISTING UTILITIES OR CONDUITS THAT ARE TO BE ABANDONED AND ARE NOT LOCATED IN THE AREA OF PROPOSED IMPROVEMENTS MAY BE CUT, CAPPED AND/OR FILLED.
  - ANY ABANDONMENT OF EXISTING ELECTRICAL, NATURAL GAS FACILITIES OR OTHER UTILITY SHALL BE COORDINATED WITH A REPRESENTATIVE FROM THE UTILITY COMPANY.
  - ALL FILL AREAS SHALL BE COMPACTED TO 95% ORIGINAL DENSITY PER STANDARD PROCTOR TEST. THIS SHALL BE CERTIFIED TO ENGINEER IN ALL AREAS OF FILL BY A LICENSED TESTING COMPANY.

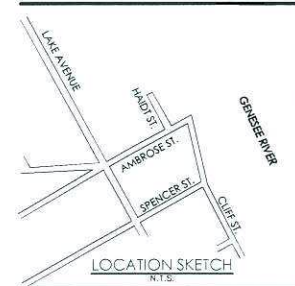
- UTILITY NOTES:**
- THE CONTRACTOR IS RESPONSIBLE TO COORDINATE ALL UTILITY CONNECTIONS WITH MECHANICAL/ARCHITECTURAL DRAWINGS FOR LOCATION, PENETRATION, AND SIZES PRIOR TO CONSTRUCTION. THE CONTRACTOR SHALL COORDINATE WITH ALL SUBCONTRACTORS FOR PROPER UTILITY CONNECTION LOCATIONS. ANY DISCREPANCIES SHALL BE IMMEDIATELY DESCRIBED TO ENGINEER AND ARCHITECT.
  - THE DEVELOPER AND HIS/HER CONTRACTOR IS RESPONSIBLE FOR COORDINATING GAS, ELECTRICAL, CABLE, TELEPHONE AND ANY OTHER UTILITIES NOT SPECIFICALLY SHOWN WITHIN THIS PLAN SET WITH APPROPRIATE AGENCY. PASSERO ASSOCIATES ASSUMES NO RESPONSIBILITY FOR THE DESIGN OR PERFORMANCE OF UTILITIES NOT SPECIFICALLY SHOWN WITHIN THIS PLAN SET.
  - THE CONTRACTOR IS RESPONSIBLE TO LOCATE ALL EXISTING UTILITIES AND CONFIRM VERTICAL AND HORIZONTAL LOCATIONS PRIOR TO THE START OF CONSTRUCTION. THE CONTRACTOR SHALL REPORT ANY CONFLICTS TO THE DESIGN ENGINEER. UPON COMPLETION THE CONTRACTOR SHALL OBTAIN WRITTEN APPROVAL FROM THE OWNERS ON-SITE REPRESENTATIVE PRIOR TO THE START OF CONSTRUCTION.
  - CONTRACTOR IS RESPONSIBLE FOR RAISING ALL FRAMES, GRATES AND COVERS TO PROPOSED GRADE WITHIN THE PROJECT AREA.

- MCPW - ROCHESTER PURE WATERS DISTRICT SEWER NOTES:**
- THIS PLAN REQUIRES APPROVAL AND ISSUANCE OF A PLUMBING PERMIT FROM THE CITY OF ROCHESTER PLUMBING DEPARTMENT.
  - PRIOR TO CONSTRUCTION, A SEWER CONNECTION PERMIT MUST BE OBTAINED FROM THE MONROE COUNTY PURE WATERS (MCPW) PERMIT OFFICE AT 444 EAST HENRIETTA ROAD, BUILDING 15, ROCHESTER, NEW YORK 14620-4443. PHONE # 753-7600 (OPT. 5).
  - SEWER CONNECTION PERMIT(S) CAN ONLY BE ISSUED TO A PLUMBER LICENSED IN THE CITY OF ROCHESTER AND WHO IS FULLY INSURED AND BONDED IN THE ROCHESTER PURE WATERS DISTRICT (RPWD). PAYMENT (CHECK OR MONEY ORDER TO "RPWD") OF ALL APPLICABLE PERMIT FEES MUST BE PAID PRIOR TO PERMIT ISSUANCE.
  - THE RPWD SHALL BE NOTIFIED FORTY-EIGHT HOURS IN ADVANCE OF A CONNECTION OR TAP. (753-7400 (OPT. 5)). THE RPWD SHALL INSPECT ALL TAPS AND CONNECTIONS TO THE RPWD SEWERS.
  - SANITARY/STORM/COMBINATION SEWER LATERAL(S) AND APPURTENANCES SHALL BE CONSTRUCTED IN CONFORMANCE WITH THE REQUIREMENTS OF THE ROCHESTER PURE WATERS DISTRICT.
  - CLEANOUTS SHALL BE INSTALLED ON ALL 4" AND 6" DIAMETER SEWER LATERALS AT THE RIGHT-OF-WAY (ROW) LINE OR THE SEWER EASEMENT LINE WHERE APPLICABLE. (THE SEWER EASEMENT, RIGHT-OF-WAY AND/OR PROPERTY LINE MUST BE STAKED OUT PRIOR TO INSTALLATION OF LOT LINE CLEANOUTS TO ENSURE PROPER LOCATION OF THE CLEANOUTS. (REFER TO CLEANOUT DETAIL FOR PROPER INSTALLATION)).
  - IF AN EXISTING LATERAL IS TO BE UTILIZED, THE PLUMBER/CONTRACTOR MUST ENSURE THAT THE LATERAL IS IN GOOD CONDITION AND IS FREE OF DEBRIS (DIRT, MUD, STONE, ROOTS, ETC.) VIA A VIDEO TAPED INSPECTION PERFORMED BY THE PLUMBER/CONTRACTOR OR HIS/HER/THEIR AGENT. PRIOR TO CONNECTION, THE VIDEO TAPED INSPECTION OF THE EXISTING LATERAL MUST BE PRESENTED TO THE DISTRICT FOR REVIEW AND APPROVAL TO UTILIZE AN EXISTING LATERAL. IT IS THE RESPONSIBILITY OF THE BUILDER OR THEIR AGENT TO CLEAN AND/OR REPLACE THE PIPE/LATERAL AS NEEDED.
  - ANY NEW PORTION OF A SEWER LATERAL INSTALLED WITHIN THE PUBLIC RIGHT-OF-WAY AND SEWER EASEMENT MUST BE SDR-21 PVC.
  - ANY EXISTING LATERALS NOT UTILIZED MUST BE ABANDONED TO MONROE COUNTY PURE WATERS (MCPW) STANDARDS AT THE PROPERTY LINE OR, WHERE APPLICABLE, THE SEWER EASEMENT LINE.
  - FLOOR DRAINS IF CONSTRUCTED SHALL BE CONNECTED TO THE SANITARY/COMBINATION SEWER. FLOOR DRAINS DO NOT INCLUDE FOUNDATION/FOOTER DRAINS. NOTE: ALL DISCHARGES TO THE SANITARY/COMBINATION SEWER MUST COMPLY WITH THE EFFLUENT LIMITS OF THE LOCAL AND/OR MONROE COUNTY SEWER USE LAW.
  - ANY PORTION OF A SEWER/LATERAL WITH LESS THAN FOUR-FOOT (4') OF COVER WILL REQUIRE CONCRETE ENCASUREMENT. SEWERS/LATERALS WITH LESS THAN THREE-FOOT (3') OF COVER ARE NOT ALLOWED.
  - THE REQUIREMENTS OF THE HIGHWAY/PROPERTY OWNER SHALL BE ADHERED TO FOR ITEMS ABOVE THE PIPE BEDDING INCLUDING, BUT NOT LIMITED TO, MAINTENANCE AND PROTECTION OF TRAFFIC, BACKFILL MATERIAL AND SURFACE RESTORATION.



**PA**  
**PASSERO ASSOCIATES**  
 Engineering • Architecture  
 www.passero.com

If you excavate anywhere in New York State, except NYC or Long Island, call  
**Dig Safely.**  
**New York**  
 1-800-962-7962  
 E-Mail: www.DigSafelyNewYork.com



Client:  
 Volunteers of America  
 214 Lake Avenue  
 Rochester, NY 14608

**PASSERO ASSOCIATES**  
 240 West Main Street, Suite 100 Rochester, New York 14611  
 (585) 325-1000  
 Fax: (585) 325-1491  
 Principal-in-Charge: John F. Caruso, P.E.  
 Project Manager: Jess D. Sudol, P.E.  
 Designer: Carole G. Harvey

**Revisions**

No.	Date	By	Description
1			

UNAUTHORIZED ALTERATIONS OR ADDITIONS TO THIS DRAWING IS IN VIOLATION OF STATE EDUCATION LAW ARTICLE 145 SECTION 7309 AND ARTICLE 147 SECTION 7307. THESE PLANS ARE COPYRIGHT PROTECTED.

**SITE, GRADING AND UTILITY PLAN**

VOA Cobbestone at Lake

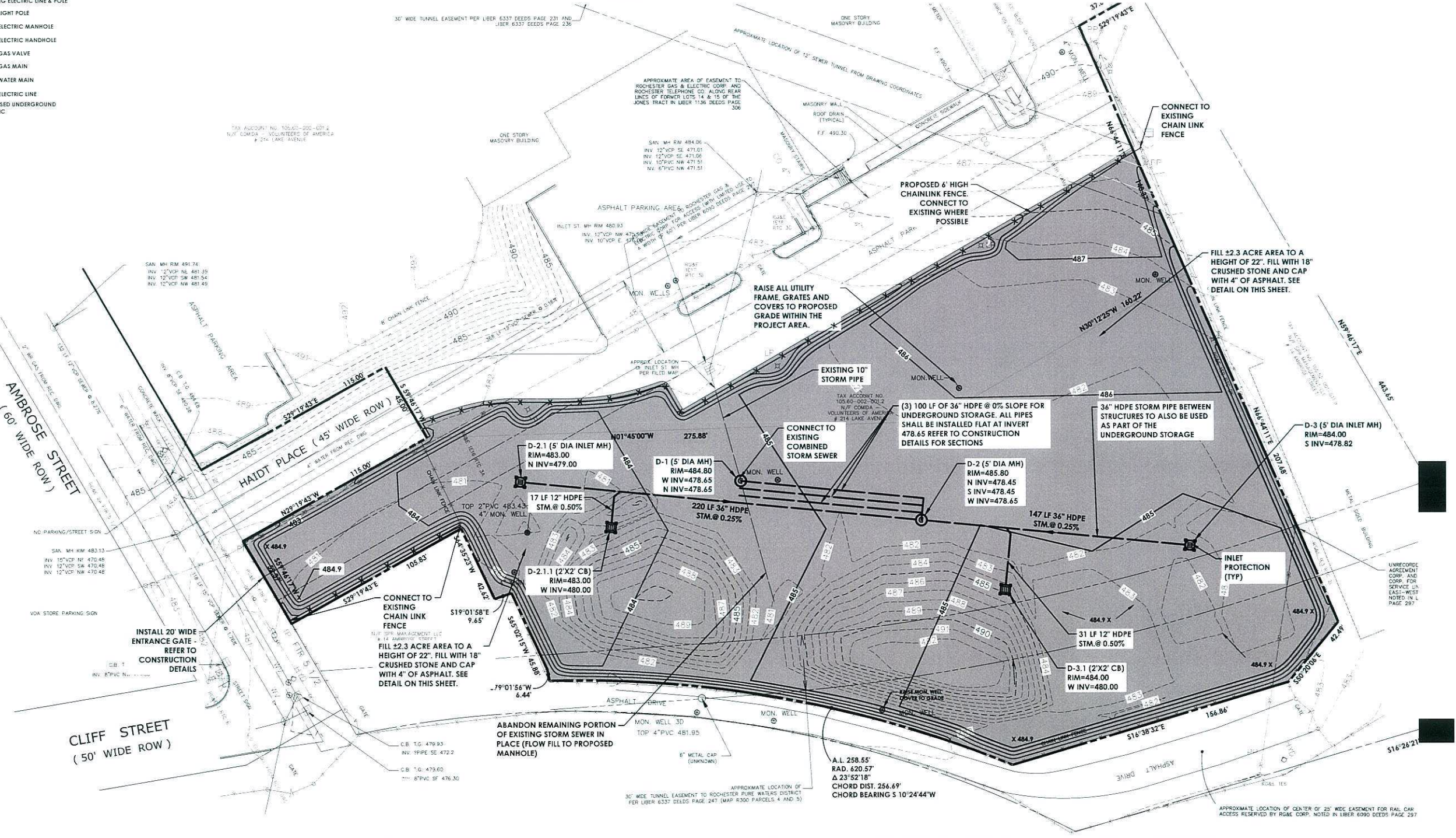
Town/City: Rochester  
 County: Monroe State: New York

Project No: 20121554.0004

Drawing No: C102 Sheet No: 2

Scale: 1" = 30'

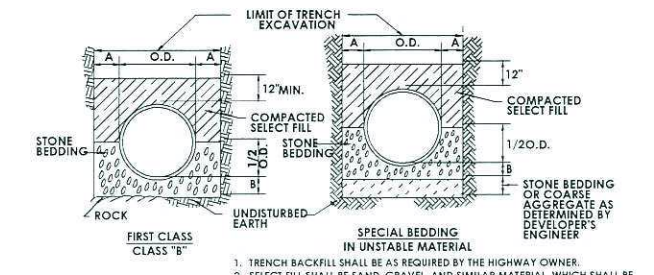
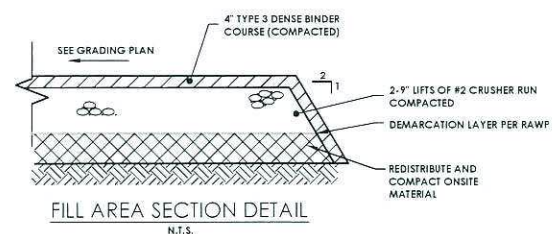
Date: NOVEMBER 2015



E:\2012\20121554\20121554.0004\DRAWINGS\ENGINEERING\20121554.0004 SITE UTILITY.DWG 11/20/2015 8:59 AM MSH Newcomb

Figure 13 – Site Wide Engineering Cover with Grading / Utilities

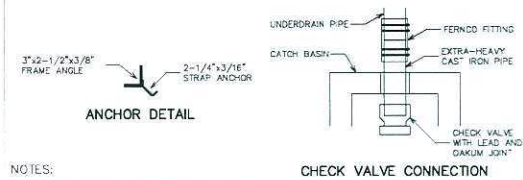
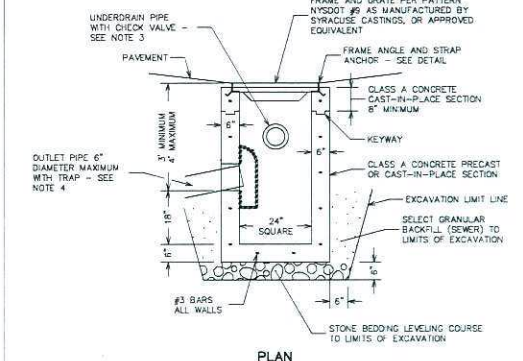




PIPE DIA.	DIM. A	DIM. B
UP TO 18"	1.0'	6"
21" TO 36"	1.5'	9"
OVER 36"	1.5'	12"

**STORM SEWER/SANITARY SEWER BEDDING DETAILS**  
N.T.S.

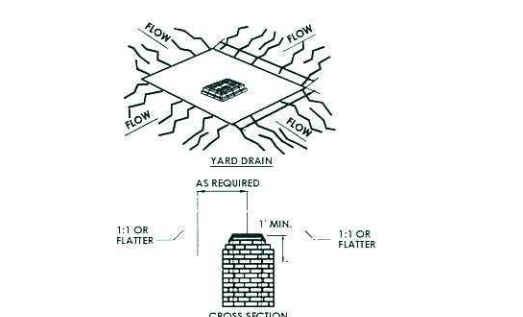
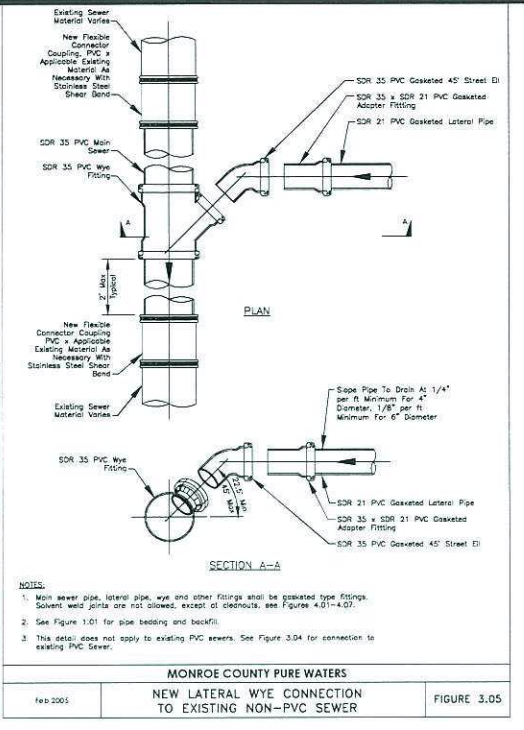
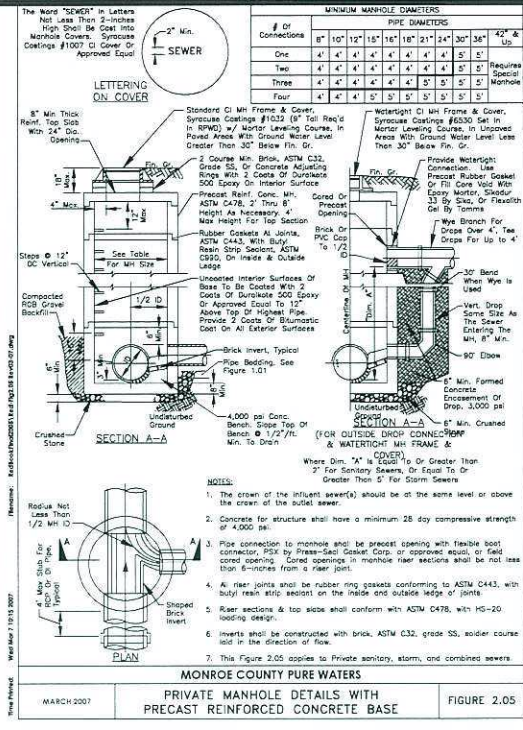
- TRENCH BACKFILL SHALL BE AS REQUIRED BY THE HIGHWAY OWNER.
- SELECT FILL SHALL BE SAND, GRAVEL, AND SIMILAR MATERIAL WHICH SHALL BE FREE FROM CLAY, LOAM, ORGANIC MATERIAL, DEBRIS, FROZEN MATERIAL AND SHALL CONTAIN ONLY SMALL AMOUNTS OF STONE, PEBBLES OR LUMPS OVER ONE INCH IN GREATEST DIMENSION BUT NONE OVER TWO INCHES IN GREATEST DIMENSION.
- STONE BEDDING SHALL MEAN APPROVED IMPORTED AGGREGATE MEETING THE REQUIREMENTS OF THE NEW YORK STATE DEPARTMENT OF TRANSPORTATION, STANDARD SPECIFICATION, JAN. 2, 1990 EDITION, AS REVISED, SUBSECTION 703-0201 "CRUSHED STONE", PRIMARY SIZE 1 OR A MIXTURE OF PRIMARY SIZES 1 AND 2.
- COARSE AGGREGATE SHALL MEAN APPROVED IMPORTED AGGREGATE MEETING THE REQUIREMENTS OF THE NEW YORK STATE DEPARTMENT OF TRANSPORTATION, STANDARD SPECIFICATION, JAN. 2, 1990 EDITION, AS REVISED, SUBSECTION 703-0201 "CRUSHED STONE", PRIMARY SIZE 3 AND/OR 4 AS WELL AS FORCE MAINS.
- THIS FIGURE APPLIES TO SANITARY MAINLINE AND LATERAL PIPE INSTALLATION AS WELL AS FORCE MAINS.



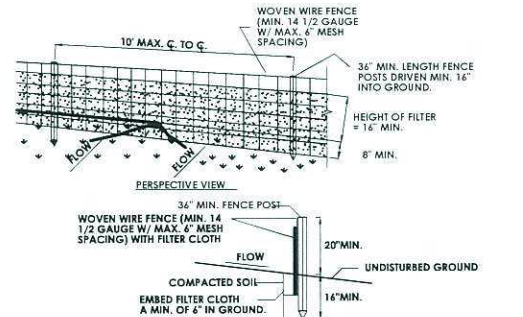
**NOTES:**

- COAT INTERIOR OF CATCH BASIN WITH 2 COATS OF TAMM'S DURAKOTE 240, OR APPROVED EQUIVALENT.
- COAT EXTERIOR OF CATCH BASIN WITH 2 COATS OF HI-BUILD BITUMINOUS COATING 35-40, HOPKINS BIMASTIC SUPER SERVICE BLACK, OR APPROVED EQUIVALENT.
- INSTALL CHECK VALVE TO PREVENT WATER FROM FLOWING BACK INTO UNDERDRAIN PIPE.
- CATCH BASIN TRAP TO BE PER NEEDHAM R-370-B OR TEE WYE WITH THREADED CLEAN-OUT PLUG ON TOP SIDE.

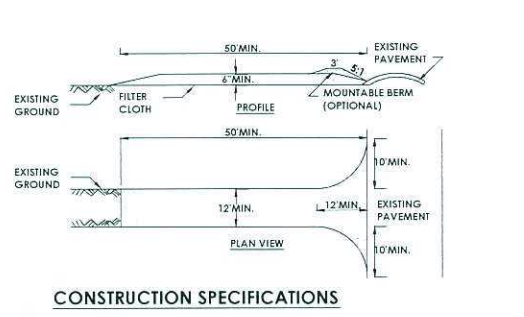
**CITY OF ROCHESTER**  
ISSUED 9-2-B1 STD. D.W.C.  
REVISED 9-19-11 NO. R604-2



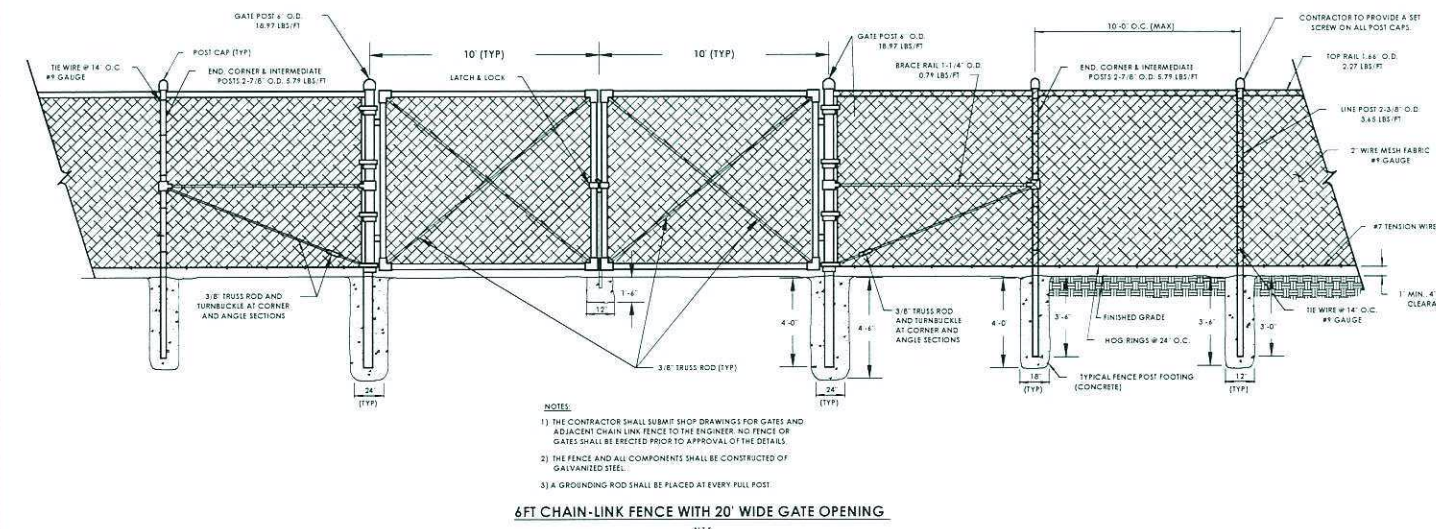
- CONSTRUCTION SPECIFICATIONS**
- SEDIMENT SHALL BE REMOVED AND THE TRAP RESTORED TO ITS ORIGINAL DIMENSIONS WHEN THE SEDIMENT HAS ACCUMULATED TO 1/2 THE DESIGN DEPTH OF THE TRAP. REMOVED SEDIMENT SHALL BE DEPOSITED IN A SUITABLE AREA AND IN SUCH A MANNER THAT IT WILL NOT ERODE. THE VOLUME OF SEDIMENT STORAGE SHALL BE 1800 CUBIC FEET PER ACRE OF CONTRIBUTORY DRAINAGE.
  - THE STRUCTURE SHALL BE INSPECTED AFTER EACH RAIN AND REPAIRS MADE AS NEEDED.
  - CONSTRUCTION OPERATIONS SHALL BE CARRIED OUT IN SUCH A MANNER THAT EROSION AND WATER POLLUTION SHALL BE MINIMIZED.
  - THE SEDIMENT TRAP SHALL BE REMOVED AND THE AREA STABILIZED WHEN THE CONTRIBUTED DRAINAGE AREA HAS BEEN PROPERLY STABILIZED.
  - ALL CUT SLOPES SHALL BE 1:1 OR FLATTER.
- MAXIMUM DRAINAGE AREA: 3 ACRES



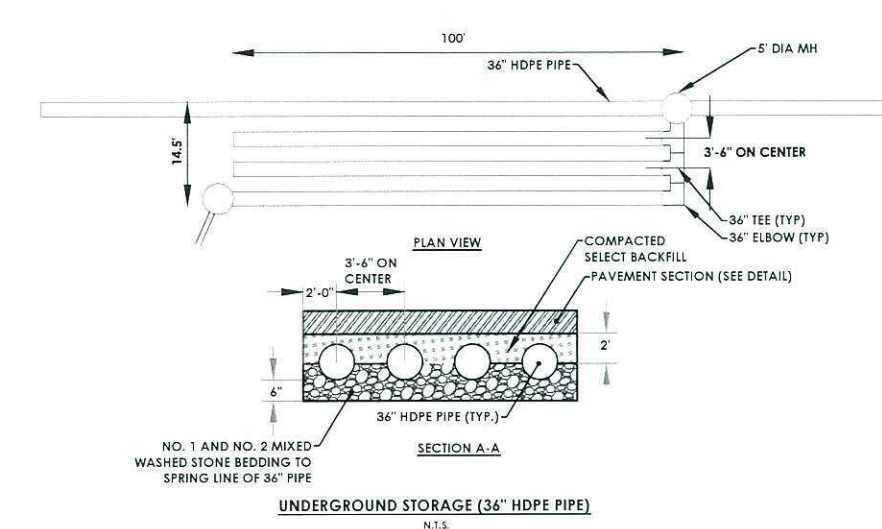
- CONSTRUCTION SPECIFICATIONS**
- WOVEN WIRE FENCE TO BE FASTENED SECURELY TO FENCE POSTS WITH WIRE TIES OR STAPLES. POSTS SHALL BE STEEL, EITHER "T" OR "U" TYPE OR HARDWOOD.
  - FILTER CLOTH TO BE FASTENED SECURELY TO WOVEN WIRE FENCE WITH TIES SPACED EVERY 24" AT TOP AND MID SECTION. FENCE SHALL BE WOVEN WIRE, 12 1/2 GAUGE, 6" MAXIMUM MESH OPENING.
  - WHEN TWO SECTIONS OF FILTER CLOTH ADJOIN EACH OTHER THEY SHALL BE OVERLAPPED BY SIX INCHES AND FOLDED. FILTER CLOTH SHALL BE EITHER FILTER X, MIFATI 100X, STABILINKA 1140X, OR APPROVED EQUIVALENT.
  - PREFABRICATED UNITS SHALL BE GEOTAB, ENVIROFENCE OR APPROVED EQUIVALENT.
  - MAINTENANCE SHALL BE PERFORMED AS NEEDED AND MATERIAL REMOVED WHEN 'BULGES' DEVELOP IN THE SILT FENCE.



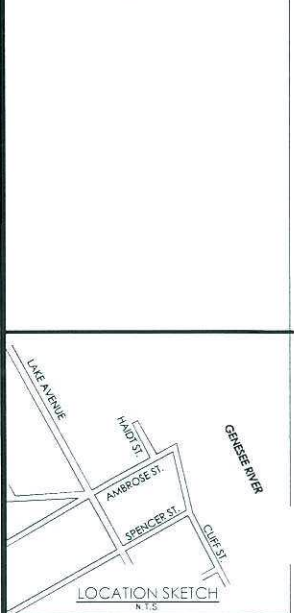
- CONSTRUCTION SPECIFICATIONS**
- STONE SIZE - USE 2" STONE, OR RECLAIMED OR RECYCLED CONCRETE EQUIVALENT.
  - LENGTH - NOT LESS THAN 50 FEET (EXCEPT ON A SINGLE RESIDENCE LOT WHERE A 30 FOOT MINIMUM LENGTH WOULD APPLY).
  - THICKNESS - NOT LESS THAN SIX (6) INCHES.
  - WIDTH - TWELVE (12) FOOT MINIMUM, BUT NOT LESS THAN THE FULL WIDTH AT A POINTS WHERE INGRESS OR EGRESS OCCURS. TWENTY-FOUR (24) FOOT IF SINGLE ENTRANCE TO SITE.
  - FILTER CLOTH - WILL BE PLACED OVER THE ENTIRE AREA PRIOR TO PLACING OF STONE.
  - SURFACE WATER - ALL SURFACE WATER FLOWING OR DIVERTED TOWARD CONSTRUCTION ENTRANCES SHALL BE PIPED ACROSS THE ENTRANCE. IF PIPING IS IMPRACTICAL, A MOUNTABLE BERM WITH 5:1 SLOPES WILL BE PERMITTED.
  - MAINTENANCE - THE ENTRANCE SHALL BE MAINTAINED IN A CONDITION WHICH WILL PREVENT TRACKING OR FLOWING OF SEDIMENT ONTO PUBLIC RIGHTS-OF-WAY. ALL SEDIMENT SPILLED, DROPPED, WASHED OR TRACED ONTO PUBLIC RIGHTS-OF-WAY MUST BE REMOVED IMMEDIATELY.
  - WHEN WASHING IS REQUIRED, IT SHALL BE DONE ON A AREA STABILIZED WITH STONE AND WHICH DRAINS INTO AN APPROVED SEDIMENT TRAPPING DEVICE.
  - PERIODIC INSPECTION AND NEEDED MAINTENANCE SHALL BE PROVIDED AFTER EACH RAIN.



- NOTES:**
- THE CONTRACTOR SHALL SUBMIT SHOP DRAWINGS FOR GATES AND ADJACENT CHAIN-LINK FENCE TO THE ENGINEER. NO FENCE OR GATES SHALL BE ERRECTED PRIOR TO APPROVAL OF THE DETAILS.
  - THE FENCE AND ALL COMPONENTS SHALL BE CONSTRUCTED OF GALVANIZED STEEL.
  - A GROUNDING ROD SHALL BE PLACED AT EVERY FULL POST.



- CONSTRUCTION SPECIFICATIONS**
- NO. 1 AND NO. 2 MIXED WASHED STONE BEDDING TO SPRING LINE OF 36" PIPE



Client:  
**Volunteers of America**  
214 Lake Avenue  
Rochester, NY 14608

**PASSERO ASSOCIATES**  
240 West Main Street, Suite 100  
Rochester, New York 14614  
Phone: (585) 525-1200  
Fax: (585) 525-1451

Principal in Charge: **John F. Caruso, P.E.**  
Project Manager: **Jess D. Sudol, P.E.**  
Designed by: **Carole G. Harvey**

**Revisions**

No.	Date	By	Description
1			

**DETAILS**  
VOA Cobblestone at Lake

Town/City: Rochester  
County: Monroe State: New York

Project No: **20121554.0004**

Drawing No: **C 200** Sheet No: **3**

Scale: **N.T.S.**

Date: **NOVEMBER 2015**

Figure 14 – Remediation Construction Specifications & Details



**SITE SPECIFIC HEALTH AND SAFETY PLAN  
EASTERN PORTION OF PARCEL A AND PARCEL B  
214 LAKE AVENUE  
ROCHESTER, NEW YORK**

*Submitted to:*  
Volunteers of America of Western New York  
214 Lake Avenue  
Rochester, New York

*Prepared by:*  
Bergmann Associates  
28 East Main Street  
Rochester, New York

July 2004  
(Revised March 2016)  
**Bergmann Job No. 8726.05**

**TABLE OF CONTENTS**

<b>1.0</b>	<b>INTRODUCTION</b>	<b>1</b>
1.1	Health & Safety Plan Overview	1
<b>2.0</b>	<b>SITE ACCESS &amp; PERSONNEL</b>	<b>2</b>
2.1	Site Access	2,3
<b>3.0</b>	<b>HEALTH &amp; SAFETY RISK ANALYSES</b>	<b>3</b>
3.1	Site Overview	3,4
3.2	Hazard Analyses	4,5,6,7
<b>4.0</b>	<b>SITE CONTROL MEASURES</b>	<b>8</b>
4.1	Site Control	8
	4.1.1 Work Zone	8
	4.1.2 Decontamination Zone	8
	4.1.3 Support Zone	8
4.2	Site Security	9
4.3	Buddy System	9
4.4	Site Communications	9
4.5	Safe Work Practice	9
4.6	Visitors	10
4.7	Nearest Medical Assistance	10
4.8	Safety Equipment	10
<b>5.0</b>	<b>EMPLOYEE TRAINING</b>	<b>10</b>
5.1	Pre-assignment & Annual Refresher Training	10
<b>6.0</b>	<b>MEDICAL SURVEILLANCE</b>	<b>10</b>
<b>7.0</b>	<b>PERSONAL PROTECTIVE EQUIPMENT</b>	<b>11</b>
7.1	Personal Protective Equipment Selection Criteria	11
7.2	Selected Personal Protective Equipment Ensembles	11,12
7.2.1	Levels of Protection	12
7.3	Personal Protective Equipment Reassessment Program	12,13
<b>8.0</b>	<b>DECONTAMINATION PROCEDURES</b>	<b>13</b>
<b>9.0</b>	<b>EMERGENCY RESPONSE</b>	<b>13</b>
9.1	Available Equipment & Emergency Authorities	13
	<b>SIGNATURE PAGE</b>	<b>14</b>

**FIGURES**

**FIGURE 1 HOSPITAL EMERGENCY ROUTE  
 ATTACHMENT 1 – Direction to Hospital**

## 1.0 INTRODUCTION

Bergmann Associates (Bergmann) has revised this Site Specific Health and Safety Plan (HASP) for work tasks associated with the planned remediation (cleanup) detailed in the Draft Remedial Action Work Plan dated March 3, 2016. The on-site cleanup work tasks include cleanup construction activities, environmental monitoring, and environmental sample collection. Volatile organic compounds (VOCs), semi-volatile organic compound (SVOC), and heavy metals have been detected in soil and groundwater on site. The completed remedial investigation (RI) evaluated the nature and extent of VOCs, SVOCs, heavy metals, PCBs, and cyanide that resulted from historical uses and previous operations at the Site. The proposed cleanup will be conducted at 214 Lake Avenue, Rochester, New York, on the eastern portion of Parcel A and Parcel B of the property (back lot). The laboratory analytical results from previous soil and groundwater samples indicate the detection of SVOCs and heavy metals that are the primary contaminants of concern (COC) on the Site. Volatile organic compounds that include: Acetone, 2-Butanone, Methylene Chloride, and Toluene were also detected in soil and groundwater samples.

This plan outlines the health and safety procedures, personal protective equipment (PPE), and field monitoring equipment required for monitoring the performance of health & safety requirements during proposed cleanup activities. Following the details outlined in the HASP is intended to minimize the potential for injury or exposure to contaminants of concern to Bergmann employees conducting work on this site.

### 1.1 Health & Safety Plan Overview

This HASP has been prepared for Bergmann personnel for activities conducted during the proposed cleanup project work. The procedures and personal protective equipment described in this plan were developed after reviewing the site environmental data that was presented in the RI report and our environmental data collected from subsurface explorations during the completed supplemental investigation (SI). Bergmann has evaluated the potential hazards that may be encountered during the above noted cleanup (remediation) work. The purpose of this HASP is to:

- Establish personnel safety/protection standards that meet or exceed the Occupational Safety and Health Administration (OSHA) Regulations;
- Define responsibilities of different organizations and personnel with contact information;
- Provide a map route to the nearest hospital;
- Establish safe operating procedures relative to the conditions encountered at the project work area;
- Define the project work area;
- Provide for anticipated contingencies that may arise during the course of remediation work; and
- Modify the HASP in response to new environmental data or conditions encountered during implementation of the remedial action.

## **2.0 SITE ACCESS & PERSONNEL**

Bergmann personnel entering the project work area at the Site must follow this HASP.

### **2.1 Site Access**

Site access will be given to Bergmann personnel and the remediation contractor. The remediation contractor is responsible for providing a health and safety plan that meet's their construction work task, safe work area and securing the project work area during work hours and during non-work hours.

#### Site Specific Health & Safety Personnel

Bergmann is responsible for the health and safety of Bergmann personnel. This responsibility includes:

- Provide overall health and safety oversight for the project;
- Prepare and/or review potential changes to this HASP and edit a task-specific addendum to the HASP, if required; and
- Monitor health and safety performance.
- One person may be designated as having the responsibilities of the key personnel listed below for this project. A description of the responsibilities of the key personnel involved in the HASP program is presented below.

#### Project Manager

The Project Manager (PM) will assist with management of on-site work tasks. The PM is responsible for:

- Managing the planned work requirements so that work performed adheres to the outlined health and safety procedures;
- Provide guidance so that personnel follow health and safety procedures; and
- Review daily work activities and field conditions encountered that may result in potential injury or exposure to contaminants of concern (COCs) as identified during project work. Provide notification of unsafe conditions noted during fieldwork to Site owner and contractor.

#### Site Health and Safety Officer

The Site Health and Safety Officer's (SHSO) responsibilities will be implemented by the on-site representative who will be present during the majority of the field phases of the project. The SHSO will be responsible for the following tasks:

- Implementing the HASP;
- Maintaining a daily record (if relevant to health and safety at the project site) of personnel activities, monitoring activities and results, exposure incidents, and personnel protection equipment usage;
- Monitoring anticipated hazards and propose modifications (if necessary) for the level of personnel protection and/or work procedures;

- Advising the PM on work activities completed and proposed work tasks or conditions which may impact health and safety requirements;
- Having copies of this HASP available on-site for review and provide copies of 40-Hour HAZWOPER certificates to NYSDEC by request; and
- Record daily weather conditions (e.g., temperature, wind speed/direction, etc.) if these conditions are relevant to health and safety at the project site.

The SHSO has the authority to suspend work activities if it is felt that the Site or weather conditions may adversely affect personnel health and safety. The SHSO will notify the PM, remediation contractor, and site owner of such actions.

### On-Site Workers

Bergmann project personnel involved in the proposed remediation activities are responsible for:

- Reading, understanding, and complying with the requirements of the HASP;
- Taking reasonable precautions to prevent incidents and to report accidents;
- Implement procedures specified in this HASP, and report deviations to the SHSO;
- Perform tasks that they are trained to do; and
- For this project, hard hats, work boots, safety glasses, and gloves are required for field project work tasks (Level D PPE).

### Visitors

Non-Site workers and Site visitors are responsible for:

- Reading, understanding, and complying with the requirements of the HASP;
- Having the required personnel protecting equipment (e.g., hard hats, safety glass, and work boots); and
- Taking reasonable precautions to prevent incidents that may result in injury.
- Limit visit time to less than an hour.
- Visitors must request and receive permission for a date and time to visit the site from the Bergmann project manager and the remediation contractor supervisor. This does not apply to NYSDEC, NYSDOH, and the Monroe County Health Department.

## **3.0 HEALTH & SAFETY RISK ANALYSES**

### **3.1 Site Overview**

The Site is located at:

Eastern Portion of Parcel A and Parcel B  
214 Lake Avenue (back lot)  
Rochester, New York

Bergmann will monitor the construction activities completed by the remediation contractor that include:

- Site grading;



- Excavation of impacted soils from the source area (hot spot) and backfilling
- Placement and compaction of re-used on-site soils and imported granular fill materials to construct the cover system or backfill excavations;
- Loading impacted soils into trucks for off-site disposal; and
- Placement and compaction of asphalt surface as part of the cover system.

Bergmann will also monitor a drilling contractor during test boring installations to allow for collection of confirmatory soil samples from the soil excavation removal area. Bergmann will monitor these subsurface explorations and collect soil samples. Bergmann will also collect groundwater samples for laboratory testing during post-remediation groundwater monitoring events.

### **3.2 Hazard Analyses**

#### Physical Hazards

- Physical hazards associated with injury from vehicles, excavator or drilling equipment;
- Physical hazards associated with investigation activities (i.e., slip or trip into excavations);
- Underground utilities injury from damage to these utilities (i.e. electric shock, fire, and explosion); and
- Heat and/or cold stress.

#### Chemical Hazards

Chemical hazards associated with volatile organic compounds (VOCs) overexposure are presented below:

##### **Toluene**

General Description: A chemical compound in liquid form that resembles benzene but is less volatile, less flammable, and less toxic. Toluene is often used as a solvent, a starting material for various industrial chemicals, and as an anti-knock agent for gasoline. This compound is also found in coal-tar light oil and petroleum.

Safety and Health: An eye and skin irritant. Acute systemic effects by inhalation and ingestion may be but are not limited to central nervous system depression, headache, dizziness, and upset stomach. Chronic effects are possible liver damage, cancer, and blindness. The OSHA PEL – 100 ppm during an 8 hour exposure period.

Chemical hazards associated with semi-volatile organic compounds (SVOCs) overexposure are presented below:

##### **Naphthalene**

General Description: A chemical compounds (hydrocarbon) usually obtained by distillation of coal tar and used especially in organic synthesis. Current use is mainly as a raw material for the production of phthalic anhydride. Former uses as a moth repellent, wood preservative, soil fumigant, veterinary product, and pharmaceutical.

Safety and Health: An eye and skin irritant. Acute systemic effects by inhalation and ingestion may be but are not limited to headaches, confusion, excitement, malaise, nausea, vomiting, abdominal pain, jaundice, and dermatitis. Chronic effects are possible liver damage, kidney damage, and cancer. The OSHA PEL – 10 ppm during an 8 hour exposure period.

### **Phenanthrene**

General Description: A chemical compound usually used to make dyes, explosives, and drugs as well as in biological research. Phenanthrene is also found in coal, coal tar, and asphalt and is associated with the incomplete combustion of fossil fuels and wood.

Safety and Health: An eye and skin irritant. Acute systemic effects by inhalation and ingestion may be but are not limited to photosensitivity. The OSHA PEL – 5 ppm during an 8 hour exposure period.

### **Fluoranthene**

General Description: A white crystalline hydrocarbon of a complex structure, found as one ingredient of the higher boiling portion of coal tar.

Safety and Health: Limited evidence that this may act as a carcinogen. Skin, eye and respiratory irritant. The OSHA PEL – 0.2 ppm during an 8 hour exposure period.

### **Acenaphthene**

General Description: A chemical compound used in the production of dyes, plastics, and pharmaceuticals. It is also used as an insecticides and fungicide and is present in coal tar.

Safety and Health: A skin, eye, and respiratory irritant. Chronic effects are possible liver and kidney damage.

### **Pyrene**

General Description: One of the less volatile hydrocarbons of coal tar, obtained as a white crystalline substance.

Safety and Health: A skin, eye, and respiratory irritant. The OSHA PEL – 0.2 ppm during an 8 hour exposure period.

### **Benzo(a)Pyrene**

General Description: A by-product of the incomplete combustion and thermal decomposition of fossil fuels and organic matter. It is present in tobacco smoke, automobile and diesel exhaust, coal tar, crude oils, and used lubricating oils.

Safety and Health: May cause cancer. An eye and skin irritant. Acute systemic and chronic effects by inhalation and ingestion may be but are not limited to reproductive system damage including reduction of fertility, possible genetic mutations, and photosensitivity. The OSHA PEL – 0.2 ppm during an 8 hour exposure period.

Chemical hazards associated with heavy metals overexposure are presented below:

### **Arsenic**

General Description: A naturally occurring element widely distributed in the earth's crust. Mining activities, smelters, coal and coal combustion by-products, withdrawal sludges, pesticides enhance the natural levels of arsenic. Inorganic arsenic compounds are mainly used to preserve wood. Organic arsenic compounds are used as pesticides, primarily on cotton plants. Arsenic salts are used as pesticides, wood preservative, for glass manufacturing, in alloys, electronics, paint pigment and in the manufacture of dyes.

Safety and Health: An eye and skin irritant. After absorption, arsenic may cause multi-organ failure. The primary target organs initially are gastrointestinal tract, the heart, brain and kidneys. The skin, bone marrow and peripheral nervous system may also be affected. The OSHA PEL – 10 ppm during an 8 hour exposure period.

### **Chromium**

General Description: A naturally occurring element found in rocks, animals, plants, soil, and in volcanic dust and gases. The metal chromium, which is the Chromium(0) form, is used for making steel. Chromium(VI) and Chromium(III) are used for chrome plating, dyes and pigments, leather tanning, and wood preserving.

Safety and Health: A confirmed carcinogen. An eye and skin irritant. Acute systemic effects by inhalation and ingestion may be but are not limited to nosebleeds, and ulcers and holes in the nasal septum, stomach upsets and ulcers, convulsions, kidney and liver damage. The Occupational Safety and Health Administration (OSHA) has set limits of 500 µg water soluble Chromium(III) compounds per cubic meter of workplace air (500 µg/m<sup>3</sup>), 1,000 µg/m<sup>3</sup> for metallic chromium(0) and insoluble chromium compounds, and 52 µg/m<sup>3</sup> for chromium(VI) compounds for 8-hour work shifts and 40-hour work weeks.

### **Mercury**

General Description: A naturally occurring metal that has several forms. The metallic mercury is a shiny, silver-white, odorless liquid. If heated, it is a colorless, odorless gas. Metallic mercury is used to produce chlorine gas and caustic soda, and is also used in thermometers, dental fillings, and batteries. Mercury salts are sometimes used in skin lightening creams and as antiseptic creams and ointments.

Safety and Health: Possible human carcinogen. An eye and skin irritant. Acute systemic effects by inhalation and ingestion may be but are not limited to lung damage, nausea, vomiting, diarrhea, and increases in blood pressure or heart rate. Chronic effects are possible damage to the brain, kidneys, and developing fetus. Effects on brain functioning may result in irritability, shyness, tremors, changes in vision or hearing, and memory problems. The OSHA PEL – 0.1 ppm during an 8 hour exposure period.

## **Lead**

General Description: Lead is a naturally occurring bluish-gray metal found in small amounts in the earth's crust and is produced as a by-product of the burning of fossil fuels, mining, and manufacturing. Lead has many different uses. It is used in the production of batteries, ammunition, metal products (solder and pipes), and devices to shield X-rays. Because of health concerns, lead from gasoline, paints and ceramic products, caulking, and pipe solder has been dramatically reduced in recent years.

Safety and Health: Lead can affect almost every organ and system in your body. The most sensitive is the central nervous system, particularly in children. Lead also damages kidneys and the reproductive system. The effects are the same whether it is breathed or swallowed. Acute systemic effects by inhalation and ingestion may be but are not limited to decreased reaction time, weakness in fingers, wrists, or ankles. Lead may cause anemia, a disorder of the blood. It can also damage the male reproductive system.

## **Selenium**

General Description: Selenium is a naturally occurring mineral element that is distributed widely in nature in most rocks and soils. Most processed selenium is used in the electronics industry, but it is also used as a nutritional supplement; in the glass industry; as a component of pigments in plastics, paints, enamels, inks, and rubber; in the preparation of pharmaceuticals; as a nutritional feed additive for poultry and livestock; in pesticide formulations; in rubber production; as an ingredient in antidandruff shampoos; and as a constituent of fungicides. Radioactive selenium is used in diagnostic medicine.

Safety and Health: Short-term oral exposure to high concentrations of selenium may cause nausea, vomiting, and diarrhea. Chronic oral exposure to high concentrations of selenium compounds can produce a disease called selenosis. The major signs of selenosis are hair loss, nail brittleness, and neurological abnormalities (such as numbness and other odd sensations in the extremities).

## **4.0 SITE CONTROL MEASURES**



## **4.1 Site Control**

Site control will minimize potential injury and exposure of COCs to workers and visitors. Site control measures also enhance response in emergency situations.

It is anticipated that project work under this program will be conducted following Level D health and safety protocol. In the event that an upgrade to Level C health and safety protocol is necessary, a meeting will be held to prepare for level C health and safety issues and this HASP will be modified. Project work areas and locations to support level C field operations will be defined and divided into distinct areas. The actual extent of the areas is considered task and location specific and will be determined in the field.

### **4.1.1 Work Zone**

The Work Zone is the area in which the potential for chemical contact/exposure may occur. Workers entering this zone will be required to be protected as defined in Section 7.0 of this HASP. The work zone is intended for 40 hour HAZWOPER OSHA-trained workers. Within this zone, the levels of protection may be changed in accordance with Section 7.4 of this HASP.

### **4.1.2 Decontamination Zone**

A decontamination zone will be required in the event that Level C health and safety protocol is necessary. The decontamination zone is the area that is established to facilitate the removal of potential contamination from equipment and personnel protective equipment. A decontamination zone will be set up adjacent to the project work area (work zone) to facilitate decontaminating equipment that is used throughout the remediation project work. The location of the decontamination zone will depend on prevailing wind direction and physical site features.

### **4.1.3 Support Zone**

A support zone may be set up outside the decontamination zone. The support zone will be used to store equipment and first aid supplies. Administrative and other support functions may occur within the support zone such as communication systems. Protective clothing (personnel protection equipment) that is used in the work zone may not be used in the support zone except in emergencies.

## **4.2 Site Security**

The SHSO or designated alternate is responsible for coordinating access to the active work zone with the remediation contractor. The remediation contractor is responsible for

site security and securing the excavations during working hours and non-working hours. When necessary to establish a work zone as defined above, the same will be identified by barricades or a barrier tape which will be placed a minimum of 10 feet from the edge of the excavation operation. Unauthorized entry should be noted in the daily field report.

#### **4.3 Buddy System**

Field activities in contaminated or otherwise potential hazardous work areas should be conducted with a buddy who is able to:

- Provide partner with assistance;
- Observe partner for signs of chemical or heat/cold exposure;
- Periodically check the integrity of partner's protective clothing; and
- Notify the SHSO or others if emergency help is needed.

#### **4.4 Site Communications**

Communications will be conducted through verbal communications. When out of audible range, verbal communications will be communicated using cellular phones or a 2-way radio.

Communications between workers in various zones shall consist of the standard hand signals, voice, or radios. A cellular phone will be used to contact appropriate agencies in the event of an emergency.

#### **4.5 Safe Work Practices**

Operating procedures consistent with general safety rules should be followed by all workers. Workers will be conscientious of others working around them and check that they are safe, and working in a safe manner.

General safety rules that will be enforced at the project work areas include the following:

- Monitor the excavation from the upwind location and periodically from the downwind location;
- Smoking will be prohibited at the Site;
- Eating and chewing gum will be prohibited at the Site;
- Field work will be conducted during daylight hours unless adequate light is provided;
- Authorized visitors that enter the Site will sign the daily field log and will also be required to read this HASP;
- Workers must thoroughly wash their hands prior to leaving the work area and decontamination zones and before eating or drinking; and
- Excessive facial hair should be minimized in the event that respiratory equipment is required for Level C project work.

#### **4.6 Visitors**

Visitors may be permitted in the immediate area of active operations with the approval from the SHSO. Visitors will not be allowed to enter in to the work zone and decontamination zones. Site visitors will be briefed on appropriate sections of the HASP

that apply to their visit time on-site. The presence of visitors will be documented on the daily log maintained by the SHSO or designated alternate during site activities. Visitor

vehicles will be restricted to Support Zones. Visitors will not be allowed in work areas, support zone, and decontamination areas during level C project work.

#### **4.7 Nearest Medical Assistance**

First Aid supplies will be located near the area of work activity, support zone, or in a field vehicle. Additional medical assistance can be summoned by dialing “911.”

The nearest medical assistance is Highland Hospital, located at 1000 South Avenue, Rochester, New York, (585- 473-2200), and is approximately 2.4 miles from the Site. The emergency route with directions to the hospital from the Site is shown on Figure 1 – Hospital Emergency Route. Additional information regarding medical assistance, evacuation routes, and emergency procedures is contained in Section 9.0 of this HASP.

#### **4.8 Safety Equipment**

In addition to the PPE necessary to conduct work activities, the following inventory of safety equipment will be available:

- First aid kit;
- Scissors for emergency equipment removal;
- Emergency eye wash;
- Electrolyte replacement drink – stored in clean area; and
- Fire extinguisher for Class ABC fires.

### **5.0 EMPLOYEE TRAINING**

#### **5.1 Pre-assignment & Annual Refresher Training**

Bergmann employees and remediation contractor personnel working on this site will be trained in accordance with OSHA 29 CFR Part 1910.120.

### **6.0 MEDICAL SURVEILLANCE**

Bergmann employees and contractors will follow their respective individual in-house medical surveillance procedures.

### **7.0 PERSONAL PROTECTIVE EQUIPMENT**

The SHSO has reviewed the environmental and historical sampling data that is relevant to this proposed soil excavation and cleanup construction work to determine potential exposure to COCs and physical hazards. This review resulted in designating the work area as a construction zone. Level D PPE has been designated as the primary level of

personnel protection that should be used during project work where contact with soil and groundwater is possible. Upgrading to Level C will be executed as required in the monitoring guidelines outlined.

## **7.1 Personal Protective Equipment Selection Criteria**

PPE requirements selected for each project work task are specified in Section 7.3 of this HASP. Equipment selection was based upon the mechanics of the task and the nature of the hazards that are anticipated. The following criteria were used in the selection of PPE equipment:

- Chemical hazards known or suspected to be present;
- Routes of entry through which the chemicals could enter the body, e.g., inhalation, ingestion, skin contact; and
- Potential for contaminant/worker contact while performing the specific task or activity.

Based on available data, we anticipate that most on-Site or near-site work activities will be performed at Level D protection. However, Level C protection will be available in the event an upgrade is required.

## **7.2 Selected Personal Protective Equipment Ensembles**

The following components of Level D PPE will be available and used as appropriate in accordance with the specifications of this HASP:

- Work boots;
- Rubber overboots (when necessary);
- Gloves during sample collection (Nitrile and/or rubber);
- Safety glasses;
- Insert-type hearing protection (when necessary);
- Hard hats;
- Long sleeve shirts and pants (no shorts);
- Leather gloves when using hand held tools; and
- Latex or nitrile gloves when sampling soil, water or debris.

It is possible that an upgrade to Level C may be required during the tasks identified during this project work. If an inhalation hazard is present or per the guidelines presented in the PPE reassessment program, the following must be added to the protective equipment:

- Full-face respirator equipped with NIOSH/OSHA-approved cartridges suitable for protection against organic vapors, acid gases, and particulates; and



- Tyvek disposable coveralls.

### 7.2.1 Levels of Protection

The following levels of protection will be used for specific work activities. Adjustments to these levels may be required given the site conditions encountered.

- Monitoring Soil borings, environmental monitoring and collection of soil samples - This work may be conducted in Level D.
- Groundwater Sampling - This work conducted in Level D.
- Monitoring remediation construction - This work conducted in Level D.

### 7.3 Personal Protective Equipment Reassessment Program

Air monitoring will be conducted during the remediation project work when excavation of COC impacted soils is performed. Such monitoring will be conducted within the work zone utilizing photoionization detection (PID) with a 10.2 eV lamp, or equivalent. Monitoring will consist of determining breathing zone concentrations of total volatile organic vapors. The air monitoring equipment utilized will be calibrated and maintained, in accordance with the manufacturer's instructions. The calibrations and checks will be provided by the vendor of the equipment.

Background readings will be obtained in the work zone, upwind, downwind, and support zone prior to excavation of COC impacted soil. Following the establishment of background PID measurement, air monitoring will be conducted in the work zone during the soil excavation activities. Periodic PID measurements will be obtained at downwind locations. The PID measurements will be utilized for evaluating potential upgrade to Level C, if necessary. This may be accomplished by comparing PID measurements to health and safety action levels. The action levels for the PID air-monitoring measurements in the worker's breathing zone are provided below:

- Upgrade from Level D to Level C if either of the following conditions exist:
- Total Organic Vapor (TOV) – greater or equal to 5 and less than 50 PID units (part per million) with compensation made for background readings sustained for a period of at least 5 minutes.
- Downgrade from Level C to Level D if both of the following conditions exist:
- Total Organic Vapor (TOV) – less than 5 PID units, above background sustained for a period of at least 5 minutes, with subsequent approval to downgrade provided by the Project Manager.

Immediate Evacuation of Area:

- Total Organic Vapor (TOV) – greater or equal to 50 PID units in the workers' breathing zone.
- Excavation of unknown soil type or containers.

If continued evacuation of the area becomes necessary, a meeting will be held to address the air monitoring results and air monitoring may be continued until levels are below evacuation criteria so the area can be reentered.

## 8.0 DECONTAMINATION PROCEDURES

Field decontamination of PPE (e.g. Boots) will consist of washing contaminated PPE with a mixture of Alconox soap and water or disposal of the boots. Modification to the decontamination protocol for PPE will be made on-Site as needed.

## 9.0 EMERGENCY RESPONSE

In the event of an emergency the following procedures will apply:

- Fire – the work area will be evacuated and the fire department will be notified. Telephone 911.
- Injury – Contact emergency medical services (Telephone 911). A qualified person will administer first aid. If injury is not a life or death situation, then self-transport to the hospital is acceptable. Directions to the hospital are attached.
- Chemical overexposure – If possible, move the victim to a safe location and contact 911 for emergency services. Have a qualified person administer first aid. If the person is conscious self-transport to the hospital is acceptable. If the person is unconscious, notify the appropriate emergency medical services at telephone number 911.

### 9.1 Available Equipment and Emergency Authorities

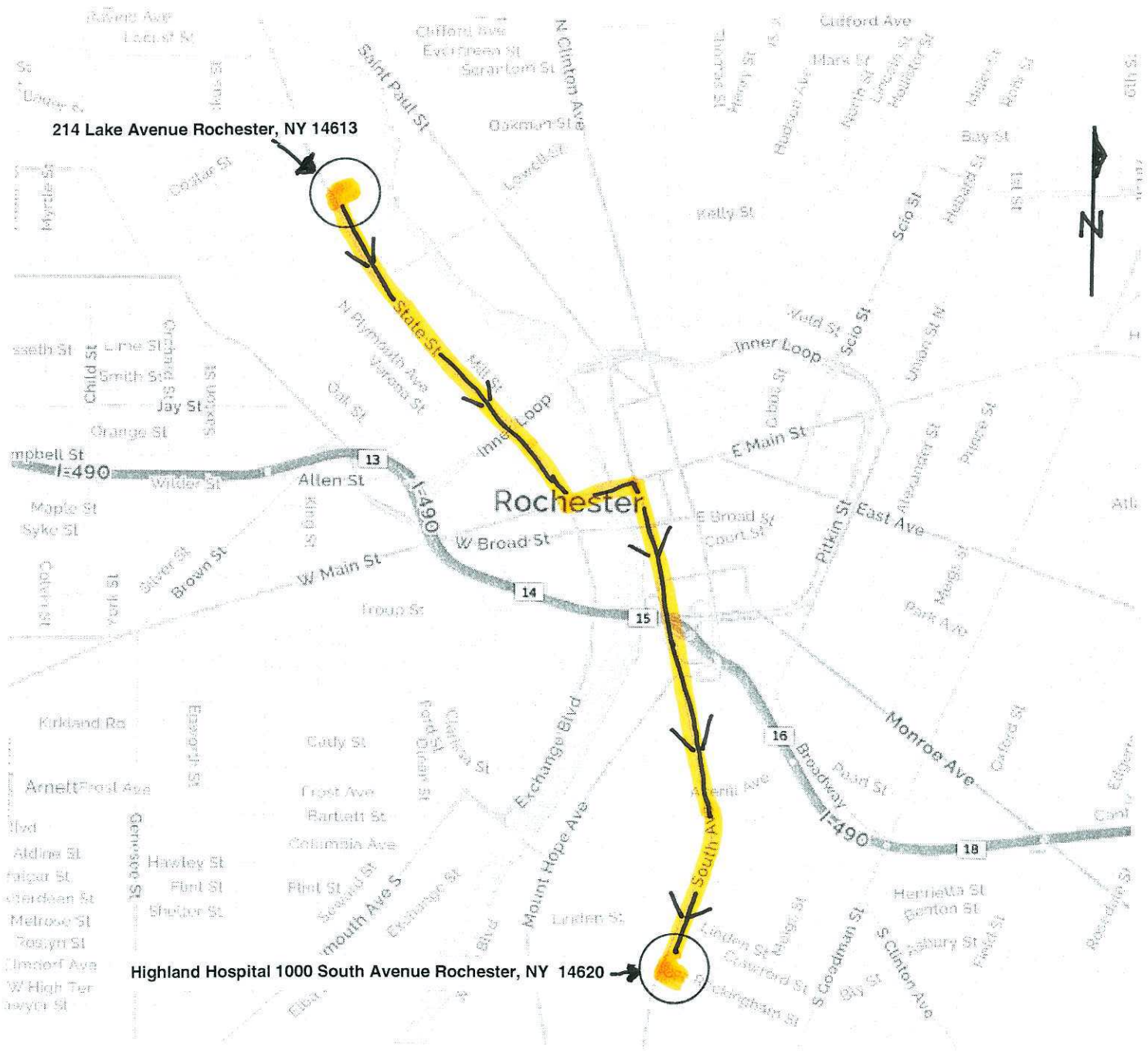
Bergmann and the remediation contractor will have a cellular telephone. If additional emergency equipment is required, the following local agencies can be called upon for advice, supplies, or additional manpower:

<u>AGENCY</u>	<u>TELEPHONE NUMBER</u>
City of Rochester Fire Department	911
Highland Hospital	911
NYSDEC – Region 8 Division of Environmental Remediation	(585) 226-5353

## SIGNATURE PAGE

By signing below, I acknowledge that I have been informed of the items covered by this plan.

PRINTED NAME	SIGNATURE



**Figure 1 - Hospital Emergency Route**



## **Attachment 1 – Driving Directions**

### **Hospital Emergency Route**

- (1) Turn left onto Lake Avenue (southeast) - 0.3 miles.
- (2) Lake Avenue becomes State Street - 0.2 miles
- (3) Turn right onto Brown Street - 0.3 miles
- (4) Turn left onto NY-31/West Broad Street - 0.1 miles
- (5) Merge onto I-490 East via the ramp on the left - 0.9 miles
- (6) Take the South Avenue exit (exit number 15) toward Route 15 (South Avenue) - 0.1 miles
- (7) Stay straight to go onto South Avenue - 1.0 miles
- (8) Highland Hospital is located at 1000 South Avenue, Rochester, New York.