

Approved
on 9/5/07

Active Subslab Depressurization System Operations Manual

(Design, Installation and Testing)

*Seneca Market I, LLC Site
Watkins Glen, New York*

May 2007
Revised August 2007

0092-002-200

Prepared For:

SENECA MARKET I, LLC
Watkins Glen, New York

Prepared By:



August 20, 2007

Charlotte B. Theobald
New York State Department of Environmental Conservation
Division of Environmental Remediation, Region 8
6274 East Avon-Lima Road
Avon, New York 14414-9519

Re: Seneca Market I, LLC
Site No. C849004
May 2007 Active Sub-slab Depressurization
System Operations Manual

RECEIVED
AUG 21 2007
DEHAZ WASTE REMED
REGION 8

Dear Ms. Theobald:

Benchmark Environmental Engineering & Science, PLLC and the Krog Corp. have reviewed The Department's June 25, 2007 comments on the May 2007 Active Sub-slab Depressurization System Operations Manual (ASD Manual). We have revised the submittal to incorporate the following acknowledged comments and responses.

Comment No. 1: *The pressure field extension or sub-slab communication test must be completed prior to occupancy. The proposed pressure field extension test presented in Section 3.3 of the Operations Manual is inadequate based on the guidance presented in United States Environmental Protection Agency's Radon Prevention in the Design and Construction of Schools and Other Large Buildings, EPA/625/R-92/016 (USEPA Guidance) and the New York State Department of Health October 2006 Guidance for Evaluating Soil Vapor Intrusion in the State of New York (NYSDOH Guidance). A sufficient number of holes should be drilled around the two suction pits, in addition to points in-between the two suction points, to demonstrate that there is sufficient communication in the entire subslab surface. Figure # 3 in the Operations Manual must be revised to show the proposed test holes for the pressure field extension test.*

RESPONSE: Acknowledged; additional test points as illustrated in the revised Figure 3 will be drilled to demonstrate that there is sufficient communication in the entire sub-slab.

Comment No. 2: *If the testing completed after the SSD system's installation indicates the system is not working properly additional details must be provided on how the system will be improved to provide sufficient communication with the sub-slab.*

RESPONSE: Acknowledged; if the testing completed after the SSD system's installation indicates the system is not working properly, additional measures will be taken as described in Section 3.3 of the revised ASD Manual (attached).

Comment No. 3: *The placement of the exhaust fans in the attic space of the hotel is not acceptable. The exhaust side of the fan is under positive pressure and potentially susceptible to leaks; therefore, the exhaust fan should be mounted outside of the building in accordance with USEPA and NYSDOH Guidance documents.*

RESPONSE: Acknowledged; the exhaust fans will be mounted on the exterior of the west side of the building and vented above the western roof as shown on Figure 3 and discussed in the revised ASD manual.

Comment No. 4: *The warning device for the system should be placed in area that is frequently visited by a SSD trained/responsible person. The SSD must operate continuously in order to provide adequate protection from soil vapor intrusion.*

RESPONSE: Acknowledged; the warning device will be placed in the maintenance area on the west side of the building. The ASD system is designed for continuous operation as indicated in the ASD Manual.

Comment No. 5: *The aggregate (ASTM # 5 or equivalent) under the building should be in accordance with published guidance to provide sufficient communication with the sub-slab surface.*

RESPONSE: Acknowledged; the sub-grade aggregate will be a # 1 or # 2 crushed stone that has a similar gradation to an ASTM # 5 material. The material will be selected to facilitate sufficient sub-grade communication, but must meet structural requirements as well.

Comment No. 6: If any natural draft combustion appliances are located in the building, the building needs to be tested for back drafting of the appliances. The back drafting can result in the accumulation of exhaust gases in the building and the potential for carbon monoxide poisoning.

RESPONSE: There are no natural draft combustion appliances planned for use in the building; all appliances will be mechanically vented.

Comment No. 7: *If this Operations Manual is to be used by the building's owner and their employees, the Operations Manual must also provide a discussion on how to interpret the system failure warning device, important maintenance items of the sub-slab system as well as the protocol to be followed in the event of a system failure. Section 5.6 of the NYSDOH Guidance should be followed.*

RESPONSE: Acknowledged; the ASD system is designed for continuous operation with little maintenance required. The system will be inspected for important maintenance items monthly and annually as described in the ASD manual and the monthly and annual operation and

Ms. Charlotte Theobald
NYSDEC

August 20, 2007
Page 3 of 3

maintenance log forms. The ASD manual has been revised to include a section (i.e., Section 4.4) to be utilized by the building owner and their employees that describes a protocol to follow in the event of system failure.

Please contact us if you have any questions or wish to discuss any of these responses further.

Sincerely,

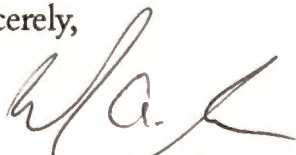

Michael Lesakowski
Project Manager

c: P. Sheedy, Krog Corp.

ACTIVE SUBSLAB DEPRESSURIZATION SYSTEM OPERATIONS MANUAL (DESIGN, INSTALLATION, & TESTING)

WATKINS GLEN, NY

(NYSDEC BCP SITE #C849004)

August 2007

0092-002-200

Prepared for:



The Krog Corp.

4 Centre Drive Orchard Park, New York 14127
716-667-1234 Fax. 667-1258

Contractors

Engineers

Developers

Table of Contents

1.0 INTRODUCTION.....	1
1.1 Background and History.....	1
2.0 Active Sub-Slab Depressurization (ASD) System Design & Installation	2
2.1 General	2
2.2 ASD System Design	3
2.3 ASD System Installation.....	4
3.0 Post Mitigation/ Confirmation Testing.....	5
3.1 General	5
3.2 Visual Inspection.....	5
3.3 ASD System Confirmation.....	5
4.0 ASD System Operation, Maintenance, & Monitoring	7
4.1 ASD System Operation	7
4.2 Monthly Visual Inspection	7
4.3 Annual Certification/Inspection	7
4.4 System Failure Protocols	8

Table of Contents

LIST OF FIGURES

Figure No.	Description
Figure 1	Site Location and Vicinity Map
Figure 2	Site Plan
Figure 3	Active Subslab Depressurization System Floor Plan
Figure 4	Active Subslab Depressurization System Design

LIST OF APPENDICES

Appendix	Description
1	Operations & Maintenance Logs
2	Exhaust Fan Product Information
3	Warning Device Product Information

1.0 INTRODUCTION

1.1 Background and History

Seneca Market I, LLC owns approximately 2.28 acres within the block bounded by Franklin, First, Decatur Streets, and the Finger Lakes Railway right-of-way in the Village of Watkins Glen, Schuyler County, New York (Site)(see Figures 1 and 2). Seneca Market I, LLC has entered into a Brownfield Cleanup Agreement (BCA) with the New York State Department of Environmental Conservation (NYSDEC) to remediate and redevelop the property under the New York State Brownfield Cleanup Program (BCP). The site is commonly referred to as the Seneca Market Site.

The portion of the Site addressed at 20 North Franklin Street was historically occupied by a dry cleaning facility. That portion of the Site was investigated and partially remediated by the NYSDEC under the NYSDEC Superfund program (i.e., “the North Franklin Street Site” - NYSDEC Registry No. 8-49-002). Due the presence of contaminated soil within the footprint of the former dry cleaning building, soil contaminated with chlorinated solvents was left in-place, with a stipulation that such soil would be excavated upon building demolition.

In accordance with the NYSDEC-approved Remedial Design Work Plan under the BCA, the former dry cleaning building was demolished and approximately 267 tons of hazardous VOC-impacted soil was excavated and transported off-site in October through December 2006. However, residual chlorinated solvents remain in Site groundwater. As such, the Remedial Design Work Plan includes provisions to design, install, monitor and maintain an active subslab depressurization system (ASD) beneath all newly constructed on-site structures to mitigate intrusion of vapors from residual VOCs in soil and groundwater.

2.0 ACTIVE SUB-SLAB DEPRESSURIZATION (ASD) SYSTEM DESIGN & INSTALLATION

2.1 General

An ASD system creates a low-pressure zone beneath a building slab using a powered fan connected via piping to create negative pressure beneath the building foundation. The low pressure field prevents soil gas from entering the building. Generally, essential components of an ASD include:

- a clean layer of coarse aggregate beneath the slab;
- installation of a suction pit beneath the slab for each building area separated by subslab walls (i.e., footings);
- installation of a vent stack from the suction pit(s) under the slab to the roof;
- installation of a continuous operation fan equipped with a pressure gauge to assure the system is under negative pressure; and,
- sealing all major slab and foundation penetrations, including joints, cracks and utility and pipe penetrations.

The active sub-slab depressurization (ASD) system utilized for this project has been designed in accordance with the EPA design document entitled "Radon Prevention in the Design and Construction of Schools and Other Large Buildings" Third Printing with Addendum, June 1994 and the NYSDOH "Guidance for Evaluating Soil Vapor Intrusion in the State of New York" dated October 2006. The designed system consists of an 8-MIL polyethylene vapor barrier, two (2) suction pits, two (2) vertical piping vent stacks and associated materials, two (2) exhaust fans, two (2) manahelic pressure gauges and two (2) system warning devices. The following text details portions of the design criteria, methodology, and critical installation methods.

2.2 ASD System Design

Structural requirements for the building will require a compacted aggregate to be placed under the slab. The system design will consist of two (2) independently operating suction pits, blowers and vent stacks spaced approximately equally from the corners of the building footprint (refer to Figure 3) to optimize the area of influence with the choice of aggregate.

An 8-mil polyethylene vapor barrier will be placed above the aggregate prior to pouring the concrete floor slab as a passive secondary engineering control and to assist in maintaining a subslab pressure differential. Suction pits will be constructed by creating a 4 ft x 4 ft x 8-inch (min. depth) void at the locations indicated in Figure 3. Each pit will then be covered by a 3/4" pressure treated plywood panel supported by concrete blocks, and reinforced concrete flooring will be poured on top of the plywood and surrounding aggregate (refer to Figure 4).

Subslab 6-inch Schedule 40 PVC piping will run laterally from the center of each suction pit as close as practicable to an adjacent roof column, elbow 90° to vertical and penetrate through a pipe sleeve in the slab. Once above the slab, the pipe will elbow 90° to horizontal and travel to the designated roof column where it will again elbow 90° to rise vertically along the column. This formation will ensure that the vent piping will not interfere with column foundations and/or footings. The vent stack will elbow 90° at the first floor of the structure and continue horizontally to the west end of the building penetrating the wall, and exhaust a minimum of 12-inches above the surface of the roof and 25 feet away from any air intake (refer to Figure 4).

A Fan Tech Model FR 160 (or similar fan; refer to Appendix 2 for specifications) will be installed inline with each vent pipe on the exterior of the western building wall to provide negative pressure in the subslab soil. A Dwyer Model 2002 – AV Magnahelic Gauge will be mounted to each vent stack in the western maintenance area of the building, using a Dwyer Model A-368 Surface mount bracket. This magnehelic gauge will measure and display the instantaneous negative pressure produced by the fan and indicates the system is operational.

A Cleveland Controls Model AFS-222 air pressure sensing switch (or similar unit; refer to Appendix 3 for specifications) will be installed inline with each vent pipe as a warning device. A red light indicator will be attached to the sensing switch; if the vent pipe does not provide a negative pressure, the red light will illuminate indicating the system is not working properly.

2.3 ASD System Installation

The ASD system will be installed in accordance with the design criteria and specifications contained in Figures 3 & 4 of this document and/or typical construction practices.

Installation of each suction pit, subslab piping, and the 8-mil polyethylene vapor barrier will be completed prior to pouring the slab. All other piping and fixtures will be installed following significant completion of the overall structure, and/or at the scheduling discretion of the owner and contractor. All 6-inch Schedule 40 PVC piping will be pitched to promote drainage of any condensate below the fan towards the suction pits.

An exhaust fan (refer to Appendix 2 for specifications) will be installed and vented a min. of 12-inches above the finished roof elevation for each system. Each fan will be hard-wired to a dedicated electrical circuit for which a dedicated breaker will be installed and properly labeled in the breaker box.

Each vent stack will extend above the exhaust fan to a point not less than 12-inches above the finished roof elevation to which a rain cap will be fastened. The vent pipe wall penetration will be sealed using a polyurethane sealant applied in accordance with the manufacturer's instructions.

Upon system installation all penetrations, expansion joints, cracks, and/or any other gaps in the slab and/or subsurface walls, will require a polyurethane sealant applied in accordance with manufacturer's instructions.

3.0 POST MITIGATION/ CONFIRMATION TESTING

3.1 General

The ASD System will require performance testing to confirm the system's effectiveness and proper installation. Post-mitigation testing will be conducted prior to building occupation and within 60 days of system installation. The following steps will be performed, documented, and then reported in the Final Engineering Report.

3.2 Visual Inspection

All system components will be visually inspected by a qualified person to ensure proper installation. With the depressurization system operating, smoke tubes may be used to check for leaks through floor joints and at suction points. Any leaks will be identified, noted, and repaired prior to continuing with testing and confirmation.

3.3 ASD System Confirmation

A field test will be conducted to confirm the negative pressure created beneath the slab. One-quarter inch diameter holes will be drilled through the concrete slab and into the sub-slab aggregate at points starting near the suction pits and continuing to points furthest from the depressurization pits that are accessible (see Figure 3). With the depressurization system operating, the vacuum will be measured using a handheld digital micro-manometer or comparable instrument at the test locations. If adequate depressurization is not occurring the following procedures will be enacted:

- All testing procedures will be repeated to ensure proper testing protocol
- Client and NYSDEC personnel will be informed of inadequate vacuum results

Troubleshooting of the system will then be completed, including the following:

- Confirmation of fan operation;
- Inspection of and sealing of all major entry routes and penetrations (if necessary);
- Location of potential subslab barriers;
- Inspection of aggregate used; and

- Inspection of the HVAC system and determination whether the HVAC system has a negative effect on the performance of the ASD system.

Upon completion of troubleshooting as described above, if re-testing sub-slab test points indicates insufficient communication the following measures will be considered:

- Adjustment of the HVAC system; and/or,
- Installation of additional suction points.

4.0 ASD SYSTEM OPERATION, MAINTENANCE, & MONITORING

4.1 ASD System Operation

This ASD System has been designed for continuous operation with minimal maintenance and/or operational oversight. It is imperative however, that the system is inspected weekly, monthly, and annually to ensure consistent and optimal operation.

Near each suction point, a magnehelic gauge will be mounted approx. 5 feet above finished floor to the column at which the vent stack is attached. When the ASD system is operational, the magnehelic gauge will display the effective sub-slab (negative) pressure.

A “normal” operating pressure will be established by recording the displayed pressure approximately 4 hours after initial system start-up. Another reading will be taken and recorded after approximately 1 week of operation to check if significant change in pressure readings is observed relative to the initial “normal” operating pressure. If there is a significant pressure difference from the “normal” operating pressure, additional weekly inspections will be made until the pressure stabilizes, for up to four weeks. If readings do not stabilize within four weeks (1 month) or a significant change in pressure readings is observed after system stabilization, the owner and/or other party responsible for the system will be notified.

4.2 Monthly Visual Inspection

On a monthly basis, the pressure at each suction pit will be read and recorded to ensure that the fan is maintaining adequate negative pressure and system components will be visually inspected. Any large fluctuations or trends in pressure will be documented and brought to the attention of the owner or other responsible party. Visible leaks in piping and/or the concrete slab will be identified and noted for repair. Changes in use of the space, modifications to the system, building renovations, and/or significant non-running time will be documented on the Monthly Inspection Log (refer to Appendix 1).

4.3 Annual Certification/Inspection

An annual system certification inspection and report documenting that the system is performing properly and remains effective will be required by the NYSDEC and is to be

submitted by a professional engineer or environmental professional. The certification report will contain the monthly logs, as well as an annual inspection checklist (refer to Appendix 1). The annual inspection will require:

- system components to be visually inspected by a qualified person;
- the exhaust fan to be inspected for signs of abnormal operation or bearing failure (service and/or replacement if necessary);
- discharge location inspection - to verify no air intake has been located nearby vent pipe;
- HVAC system inspection to determine if it is being maintained and operated as designed; and,
- detailed floor, wall, and slab inspection for cracks (resealing if necessary); smoke tubes may be used to check for leaks through floor joints and at suction points with the depressurization system running.

4.4 System Failure Protocols

In the event that the system is not working properly, the warning light located in the maintenance area will illuminate indicating that there is insufficient vacuum in the associated vent pipe. The following protocol should be followed:

- The building owner/operator and head maintenance person should be contacted immediately;
- The building owner/operator should apprise the NYSDEC of the system failure;
- The date and time should be recorded;
- The warning device should be identified (i.e., Vent #1 or #2)
- The fans should be inspected to confirm operation; if a circuit breaker was tripped causing the fan to cease operation, the circuit breaker should be reset;
- System components should be visually inspected for signs of damage or dysfunction;

If the system failure is not remedied, the building owner should contact a qualified engineer or other person with experience in ASD systems to inspect the system and take the necessary measures to place the system back in service. The NYSDEC

should be apprised of the system failure and what measures were taken to place the system back in service.

FIGURES

FIGURE 1

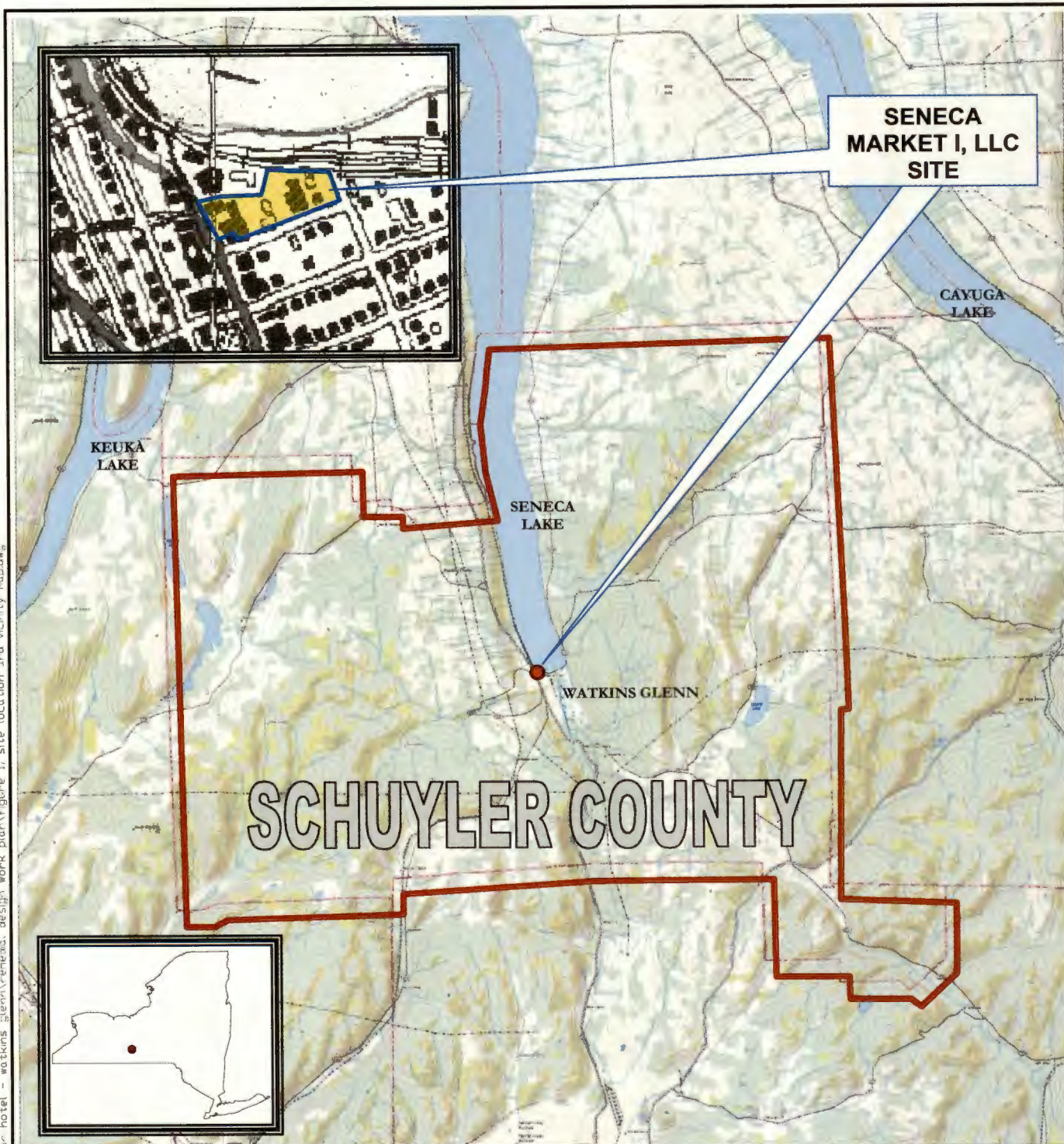

\\LEPA\fig\cadd\geoincma\k\rog\seneca\h\hotel - watkins glenn\remeds. design\work_plan\figure 1. site location and vicinity map.dwg



© 2002 DeLorme, 3-D TopoQuads®. Data copyright of content owner.
www.delorme.com



726 EXCHANGE STREET
SUITE 624
BUFFALO, NEW YORK 14210
(716) 856-0599

SITE LOCATION AND VICINITY MAP

SUBSLAB DEPRESSURIZATION SYSTEM OPERATIONS MANUAL

SENECA MARKET I, LLC SITE
VILLAGE OF WATKINS GLEN, NEW YORK

PREPARED FOR
SENECA MARKET I, LLC

PROJECT NO.: 0092-002-100

DATE: MARCH 2007

DRAFTED BY: BCH/WJM

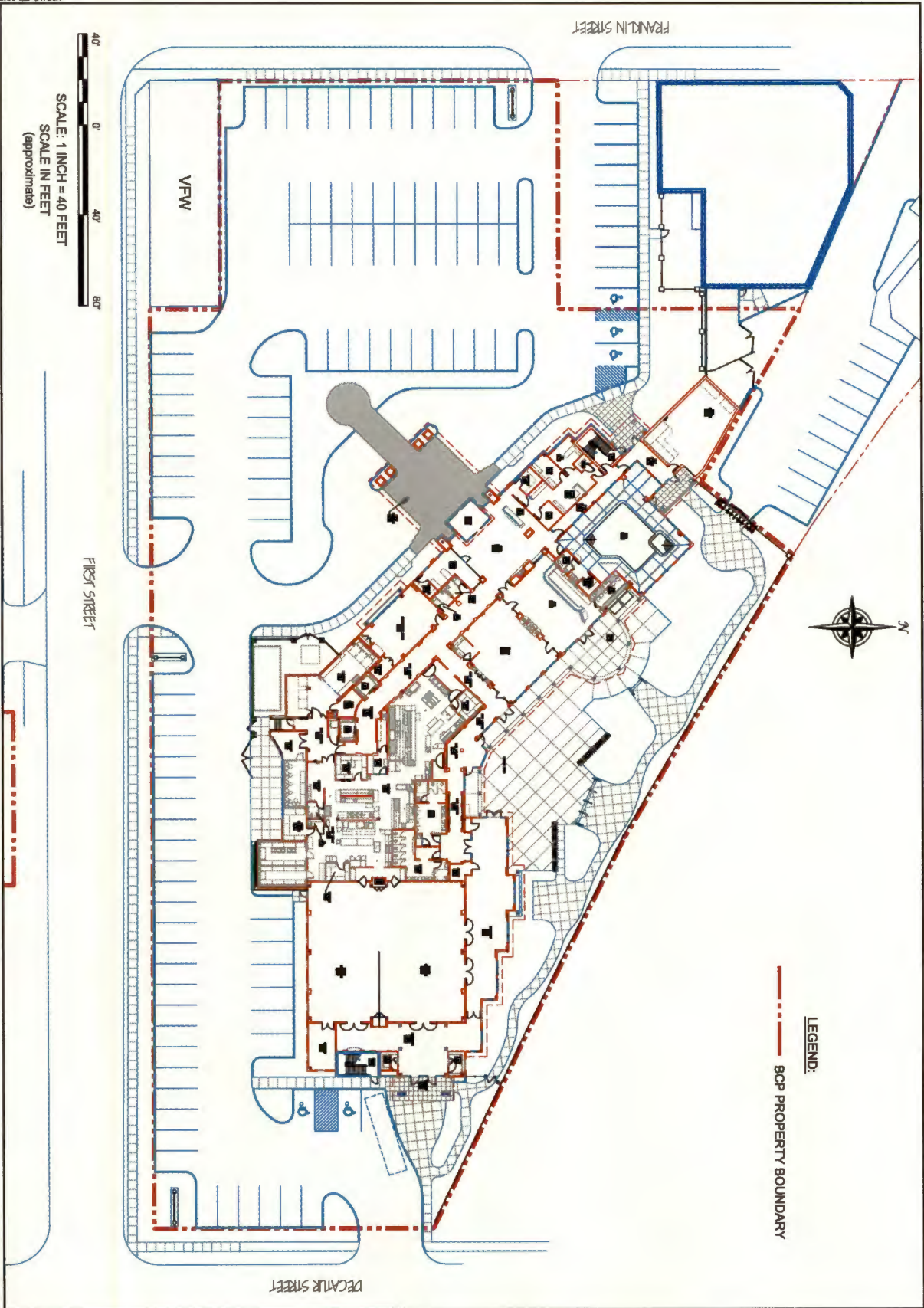

FIGURE 2

SITE PLAN
 SUBSLAB DEPRESSURIZATION SYSTEM OPERATIONS MANUAL
 SECECA MARKET I, LLC SITE
 WATKINS GLEN, NEW YORK

PREPARED FOR
 SENECA MARKET I, LLC

BENCHMARK
 ENVIRONMENTAL
 ENGINEERING &
 SCIENCE, PLLC

786 EXCHANGE STREET
 SUITE 684
 BUFFALO, NEW YORK 14210
 (716) 866-0699

JOB NO.: 0092-002-100

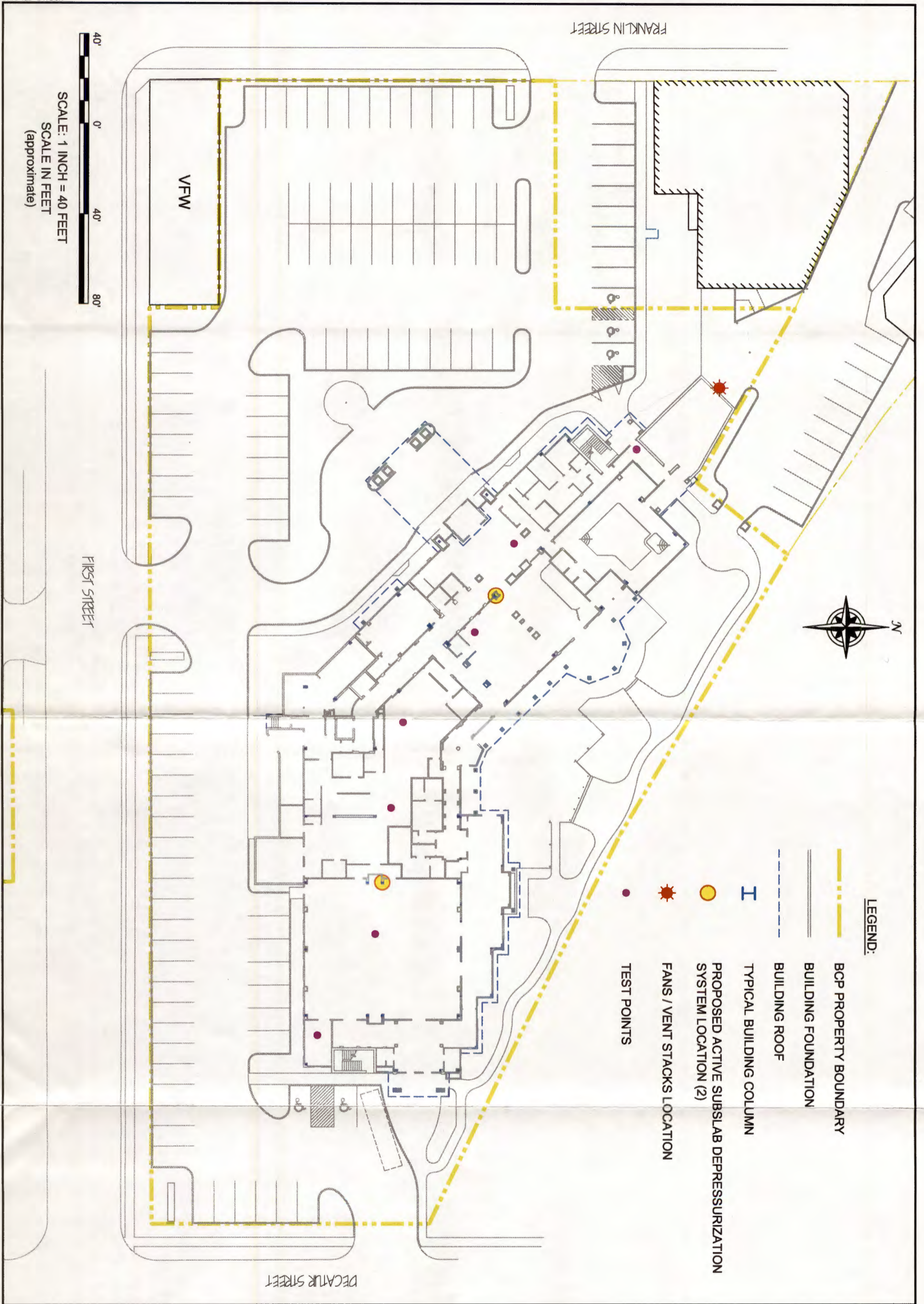

FIGURE 3

ASD SYSTEM FLOOR PLAN
 SUBSLAB DEPRESSURIZATION SYSTEM OPERATIONS MANUAL

SECECA MARKET I, LLC SITE
 WATKINS GLEN, NEW YORK

PREPARED FOR
 SENECA MARKET I, LLC



726 EXCHANGE STREET
 SUITE 624
 BUFFALO, NEW YORK 14210
 (716) 858-0599

JOB NO.: 0092-002-100

F:\CAD\Benchmark\Comp\Senecca Harbor Hotel - Watkins Glen\Active Subslab Depressurization (ASD) System\Figure 4, Active Subslab Depressurization System.dwg

SECTION VIEW:

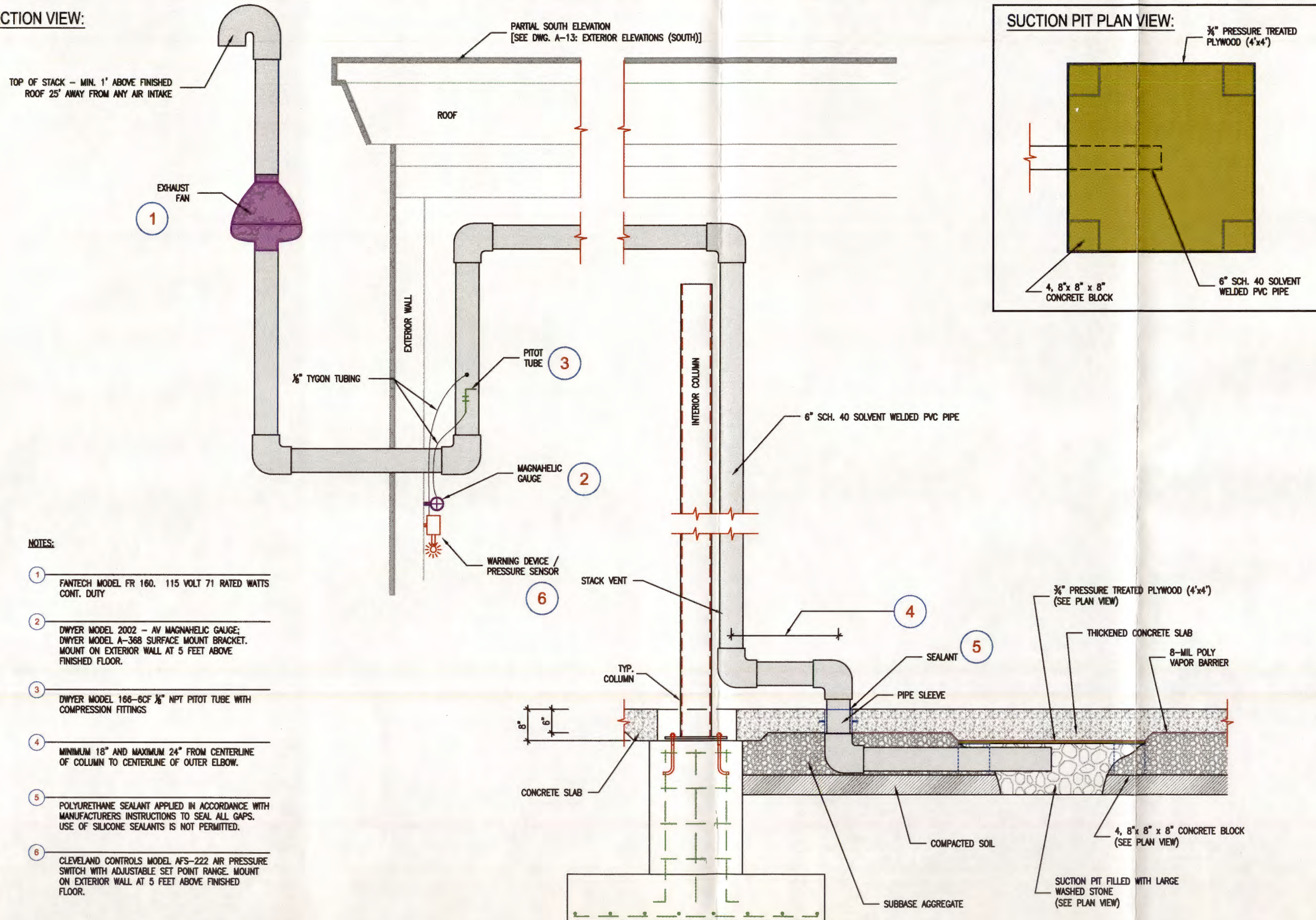

NOTES:

- 1 FANTECH MODEL FR 160. 115 VOLT 71 RATED WATTS CONT. DUTY
- 2 DWYER MODEL 2002 - AV MAGNAHELIC GAUGE; DWYER MODEL A-368 SURFACE MOUNT BRACKET. MOUNT ON EXTERIOR WALL AT 5 FEET ABOVE FINISHED FLOOR.
- 3 DWYER MODEL 166-6CF 1/8" NPT PITOT TUBE WITH COMPRESSION FITTINGS
- 4 MINIMUM 18" AND MAXIMUM 24" FROM CENTERLINE OF COLUMN TO CENTERLINE OF OUTER ELBOW.
- 5 POLYURETHANE SEALANT APPLIED IN ACCORDANCE WITH MANUFACTURERS INSTRUCTIONS TO SEAL ALL GAPS. USE OF SILICONE SEALANTS IS NOT PERMITTED.
- 6 CLEVELAND CONTROLS MODEL AFS-222 AIR PRESSURE SWITCH WITH ADJUSTABLE SET POINT RANGE. MOUNT ON EXTERIOR WALL AT 5 FEET ABOVE FINISHED FLOOR.

SUCTION PIT PLAN VIEW:

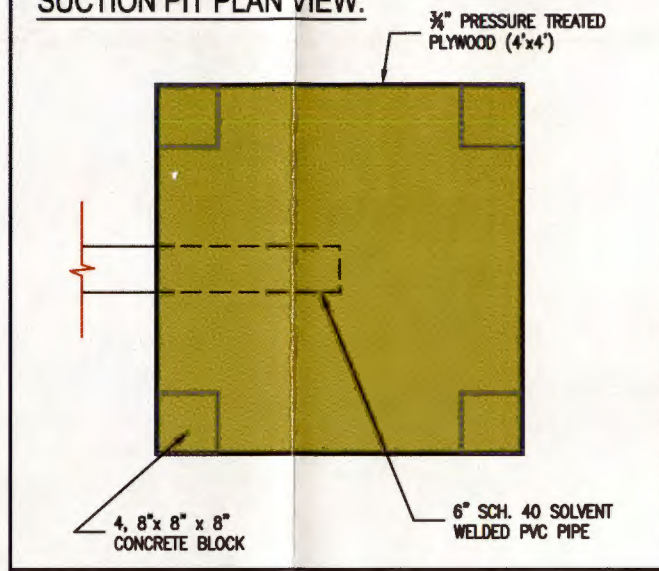

ACTIVE SUBLAB DEPRESSURIZATION SYSTEM ASSEMBLY DESIGN

SUBLAB DEPRESSURIZATION SYSTEM OPERATIONS MANUAL
 SENECA MARKET I, LLC SITE
 WATKINS GLEN, NEW YORK

BENCHMARK
 ENVIRONMENTAL
 ENGINEERING &
 SCIENCE, PLLC
 726 EXCHANGE STREET
 SUITE 824
 BUFFALO, NEW YORK 14210
 (716) 856-0599

JOB NO.: 0092-002-100

PREPARED FOR
 SENECA MARKET I, LLC

FIGURE 4

DATE: AUGUST 2007
 DRAFTED BY: BCH/WAM

APPENDIX 1

OPERATIONS AND MAINTENANCE LOGS

Monthly Operation & Maintenance Log Active Sub-Slab Depressurization System

Project Name:	Project No.:
Project Location:	Client:
Preparer's Name:	Date/Time:

Notes:

Monthly Operating Status:

System(s) currently running? yes no

Has the system been off-line in the past month? yes no

If yes, please list the dates and brief description why (i.e. maintenance, part replacement, etc.):

What is the current Vacuum reading?

Visual Inspection:

Any piping disconnected?	<input type="checkbox"/> yes	<input type="checkbox"/> no
Any cracks visible in piping?	<input type="checkbox"/> yes	<input type="checkbox"/> no
Any new cracks visible in slab floor?	<input type="checkbox"/> yes	<input type="checkbox"/> no
Magnehelic gauge reading 0?	<input type="checkbox"/> yes	<input type="checkbox"/> no

If yes to any question above, please provide more information below.

Monthly Operation & Maintenance Log Active Sub-Slab Depressurization System

Change in Occupancy / Use of Space:

Please indicate general use of floor space? _____

Has this general use changed in the past month? yes no

If yes, please explain:

System Modifications:

Have any modifications been made to the Sub-Slab Depressurization System? yes no

If so, please list with date:



Annual Operation & Maintenance Active Sub-Slab Depressurization System Certification Checklist

Project Name: _____ Project No.: _____
Project Location: _____ Client: _____
Preparer's Name: _____ Date/Time: _____

Notes:

System Information

Has monthly system inspection been completed regularly? yes no
Are last 11 inspection logs attached for the past 12 months? yes no

What is the current Vacuum reading?

System Updates, Maintenance, Part Replacement



Annual Operation & Maintenance Active Sub-Slab Depressurization System Certification Checklist

Change in Occupancy / Use of Space:

Please indicate general use of floor space? _____

Has this general use changed in the past year? yes no

If yes, please explain:

Building Renovations:

Have any building renovations taken place in the last month? yes no

If yes, please provide more information below, and sketch any basement floor plan modifications on the floor plan sketch below.

System Modifications:

Have any modifications been made to the Sub-Slab Depressurization System? yes no

If so, please list with date:

Annual Operation & Maintenance Active Sub-Slab Depressurization System Certification Checklist

Floor Plan Sketch:

Draw a plan view sketch of the basement of the building. Indicate Sub-Slab Depressurization system location. Please also note and include, any alterations to the system, locations of visible cracks and/or repairs needed, and changes or alterations to the usage of this space.

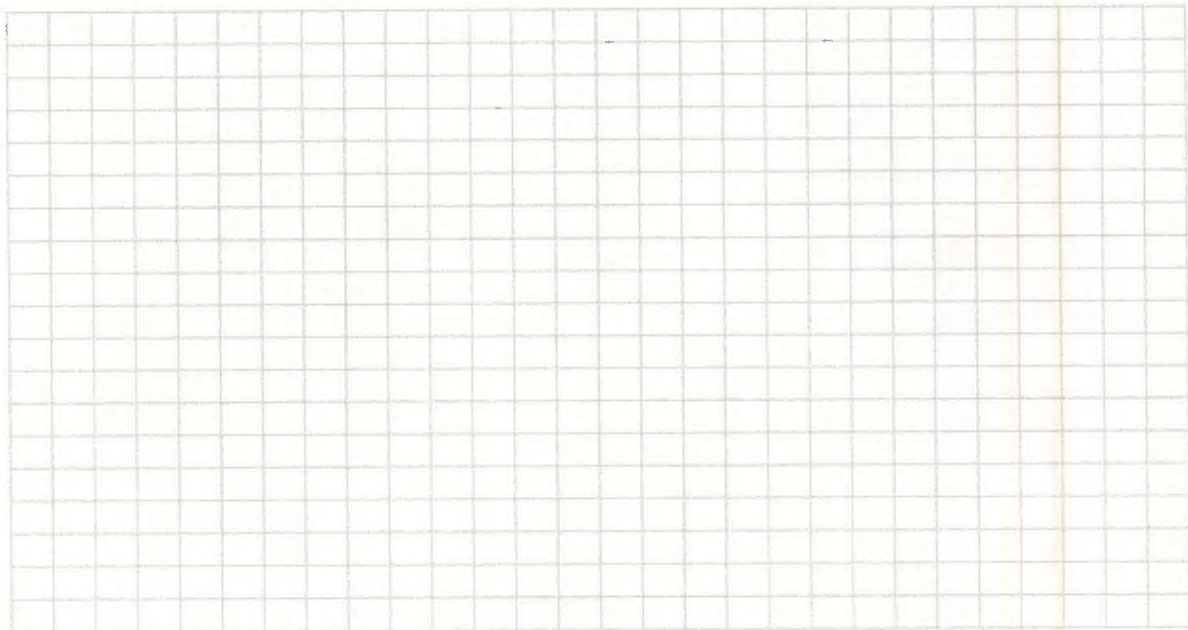
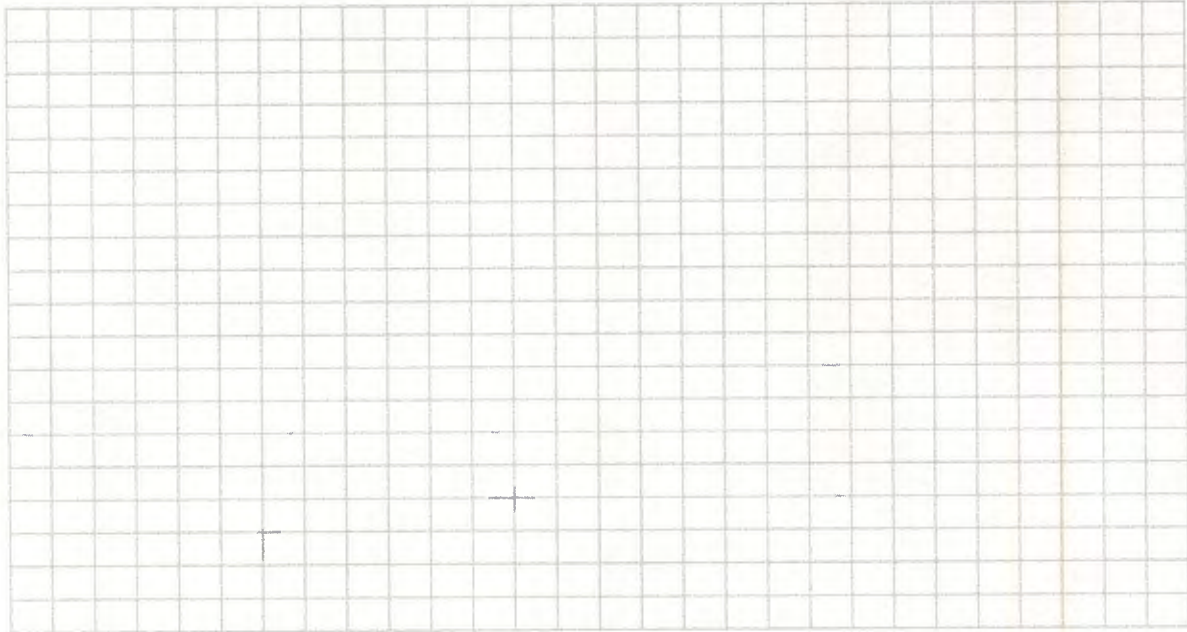

APPENDIX 2

EXHAUST FAN PRODUCT INFORMATION



Fantech FR Series

Versatility and Value

Fantech's versatile FR Series fans feature a plastic housing constructed of UL-recognized, UV-protected thermoplastic resin. This tough protective shell allows the fan to be mounted in outdoor and wet locations.* Ideal for multiple point exhaust, dual bathroom exhaust, or new room additions, Fantech's FR Series fans are caulked at the motor screws, the wiring cables and along the seams of the fan to prevent moisture from entering the housing. Fantech's FR Series fans have long been the choice of residential builders and remodelers but now can be used for commercial projects with our recent UL commercial applications rating.

Easy to install Loaded with features

- Prewired and supplied with a mounting bracket for easy installation
- Available singularly with bracket or in a variety of kits for specific applications. Each kit includes the appropriate fan and accessories
- UL Listed; CSA Certified
- Approved for residential and commercial applications and for wet locations
- Suitable for airstream temperatures up to 140° F
- Easy connection using external wiring box with waterproof gasket
- 122-649 CFM
- 4" to 10" duct diameters
- 100% speed controllable
- Five-year factory warranty

Kits are available for the following applications:

- Regular Kits (REG 100 and REG 140) for single point exhaust applications
- Deluxe Kits (DLX 110, DLX 150, and DLX 200) designed for dual point exhaust applications
- Vent Light Kits (REG 100L, DLX 150L) for single and dual vent light exhaust applications



Typical attic installation

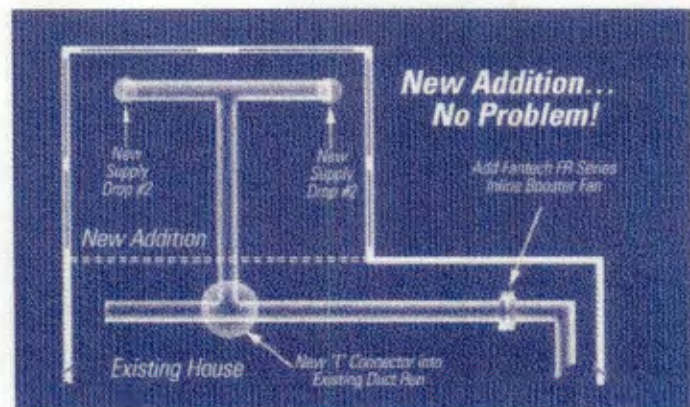
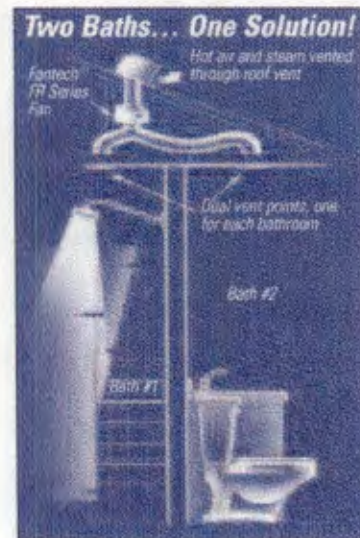

* The FR Series is not manufactured to operate with water running through the motor compartment, or to be used in applications where the fan would be buried underground. A UL-recognized waterproof conduit should be used for all outdoor applications to prevent moisture entry via knockout in wiring box.

FR Kits

Pictured from left to right: DLX150 – Dual Point Ventilation Kit; REG100L – Single Vent Light Kit. Additional kits (not pictured) are available.



DLX150



REG100L

Specifications

FR Series Dimensional Data

model	A1	A2	C	D	E	F
FR 100	4	5	9½	6¼	7½	7½
FR 110	4	5	9½	6¼	7½	7½
FR 125	—	5	9½	6¼	7½	—
FR 140	6	6¼	11¼	57/8	1	7/8
FR 150	6	6¼	11¼	57/8	1	7/8
FR 160	6	6¼	11¼	6	1	7/8
FR 200	8	10	13¼	6¼	1½	1½
FR 225	8	10	13¼	6¼	1½	1½
FR 250	—	10	13¼	6¼	1½	—

All dimensions in inches. ¹ Duct connections are 1/8" smaller than duct size.

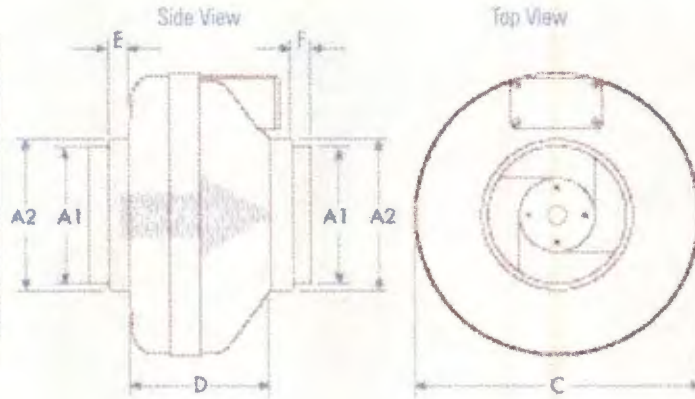

FR Series Air Performance Graphs

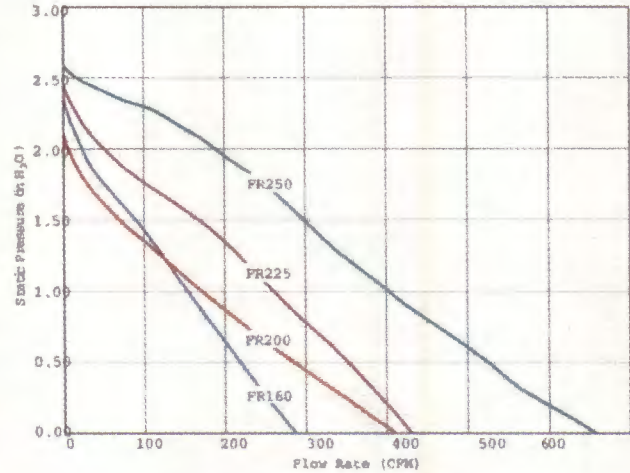
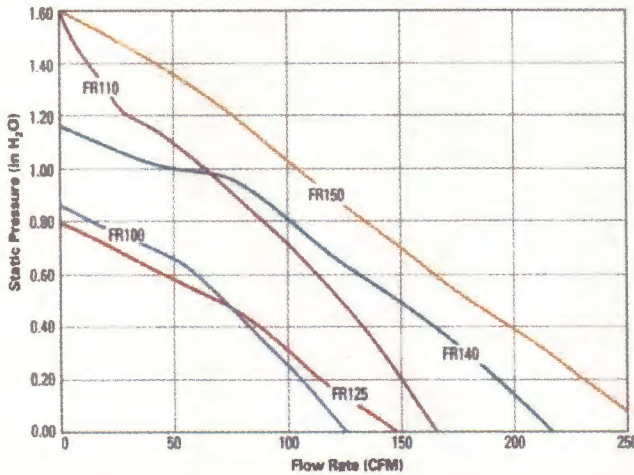

FR Series Performance Data

Fan Model	Energy Star	RPM	Volts	Rated Watts	Wattage Range	Max Amps	Static Pressure, in Inches W.G.							Max Ps	Duct Dia
							0"	2"	4"	6"	8"	10"	15"		
FR 100	✓	2900	115	19	13 - 19	0.18	122	100	78	55	15	—	—	0.87"	4"
FR 110	—	2900	115	80	62 - 80	0.72	167	150	133	113	88	63	4	1.60"	4"
FR 125	✓	2950	115	18	15 - 18	0.18	148	120	88	47	—	—	—	0.79"	5"
FR 140	✓	2850	115	61	47 - 62	0.53	214	190	162	132	99	46	—	1.15"	6"
FR 150	✓	2750	120	71	54 - 72	0.67	263	230	198	167	136	106	17	1.58"	6"
FR 160	—	2750	115	129	103 - 130	1.14	289	260	233	206	179	154	89	2.32"	6"
FR 200	✓	2750	115	122	106 - 128	1.11	408	360	308	259	213	173	72	2.14"	8"
FR 225	✓	3100	115	137	111 - 152	1.35	429	400	366	332	297	260	168	2.48"	8"
FR 250	—	2850	115	241	146 - 248	2.40	649	600	553	506	454	403	294	2.58"	10"

FR Series performance is shown with ducted outlet. Per HVI's Certified Ratings Program, charted air flow performance has been derated by a factor based on actual test results and the certified rate at .2 inches WG.

APPENDIX 3

WARNING DEVICE PRODUCT INFORMATION



Cleveland Controls
Division of UniControl Inc.

Model
AFS-222

AIR PRESSURE SENSING SWITCH WITH ADJUSTABLE SET POINT RANGE

APPLICATION

Model AFS-222 Air Pressure Sensing Switch is a general purpose proving switch designed for HVAC and Energy Management applications. It may be used to sense positive, negative, or differential air pressure.

GENERAL DESCRIPTION & OPERATION

The plated housing contains a diaphragm, a calibration spring and a snap-acting SPDT switch. The sample connections located on each side of the diaphragm accept 1/4" OD metallic tubing via the integral compression ferrule and nut.

An enclosure cover guards against accidental contact with the live switch terminal screws and the set point adjusting screw. The enclosure cover will accept a 1/2" conduit connection.

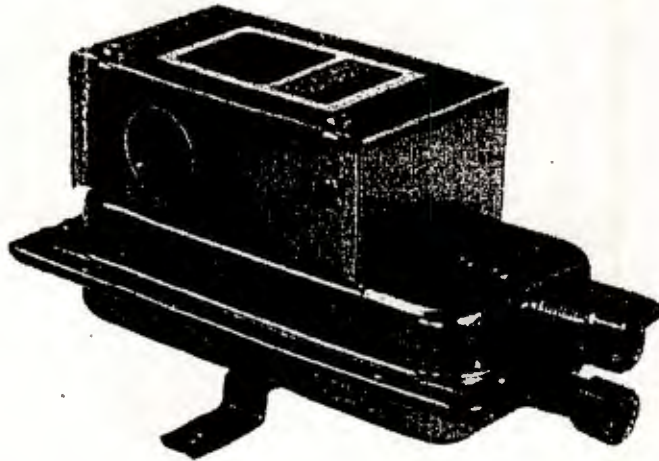

MOUNTING (SEE FIGURE 1)

Select a mounting location which is free from vibration. The AFS-222 must be mounted with the diaphragm in any vertical plane in order to obtain the lowest specified operating set point. Avoid mounting with the sample line connections in the "up" position. Surface mount via the two 3/16" diameter holes in the integral mounting bracket. The mounting holes are 3-7/8" apart.

The AFS-222 is designed to accept firm-wall sample lines of 1/4" OD tubing by means of

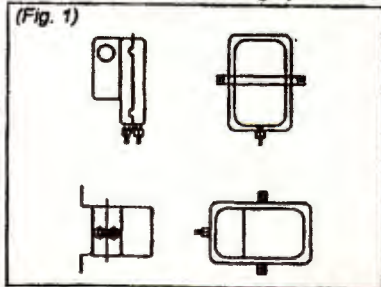

AIR SAMPLING CONNECTION (SEE FIGURE 2)

ferrule and nut compression connections. For sample lines of up to 10 feet, 1/4" OD tubing is acceptable. For lines up to 20 feet, use 1/2" ID tubing. For lines up to 60 feet, use 3/4" ID tubing. A 1/2" OD adapter, suitable for slip-on flexible tubing is available: order part number 18311.

Locate the sampling probe a minimum of 1.5 duct diameters downstream from the air source. Install the sampling probe as close to the center of the airstream as possible. Refer to Figure 2 to identify the high pressure inlet (H) and the low pressure inlet (L). Select one of the five application options listed below, and connect the sample lines as recommended.

POSITIVE PRESSURE ONLY: Connect the sample line to inlet H; inlet L remains open to the atmosphere.

NEGATIVE PRESSURE ONLY: Connect the sample line to inlet L; inlet H remains open to the atmosphere.

TWO NEGATIVE SAMPLES: Connect the higher negative sample to inlet L. Connect the lower negative sample to inlet H.

TWO POSITIVE SAMPLES: Connect the higher positive sample to inlet H. Connect the lower positive sample to inlet L.

ONE POSITIVE AND ONE NEGATIVE SAMPLE: Connect the positive sample to inlet H. Connect the negative sample to inlet L.



Cleveland Controls
DIVISION OF UNICONTROL INC.
1111 Brookpark Rd
Cleveland OH 44109

Tel: 216-398-0330

Fax 216-398-8558

Email sales@unicontrolinc.com

Web page <http://www.clevelandcontrols.com>

Are you reading a FAX or a COPY of this bulletin? **DOWNLOAD** the full-color PDF version of this and other literature at our website!

(Figure 2)

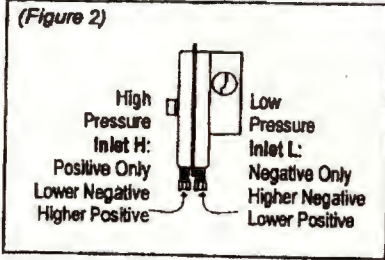

(Figure 3)

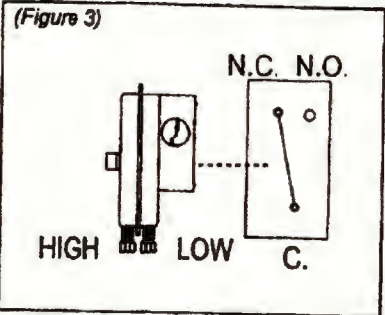

(Figure 4)

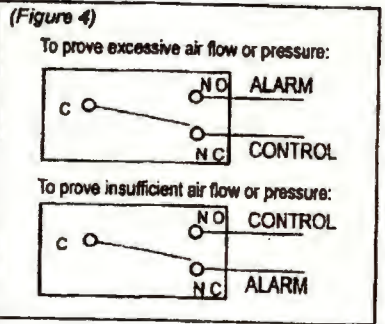

ELECTRICAL CONNECTIONS (SEE FIGURE 3)

Before pressure is applied to the diaphragm, the switch contacts will be in the normally closed (NC) position. The snap switch has screw top terminals with cup washers. Wire alarm and control applications as shown in Figure 4.

FIELD ADJUSTMENT

The adjustment range of an AFS-222 Air Switch is 0.05 ± 0.02" w.c. to 12.0" w.c. To adjust the set point, turn the adjusting screw counterclockwise until motion has stopped. Next, turn the adjusting screw 4 complete turns in a clockwise direction to engage the spring. From this point, the next ten turns will be used for the actual calibration. Each full turn represents approximately 1.2" w.c.

Please note: To properly calibrate an air switch, a digital manometer or other measuring device should be used to confirm the actual set point.

SPECIFICATIONS

MODEL AFS-222 AIR PRESSURE SENSING SWITCH WITH ADJUSTABLE SET POINT RANGE

Mounting: Rack or Panel Mount with the diaphragm in any orientation.

Set Point Range: 0.05 to 12.0 w.c.

Electrical Rating: 20 w.c.

Field Adjustment Range: 0.05 to 12.0 w.c.

Field Adjustment Range: 0.05 to 12.0 w.c.

Approximate Accuracy: ± 0.02 w.c.

Pressure: 0.05 to 12.0 w.c.

Material: 304 Stainless Steel

Weight: 1.0 lb.

Operating Temperature Range: -40 to 150 °F

Operating Pressure Range: 0.05 to 12.0 w.c.

Operating Voltage: 24 VDC

Operating Current: 10 mA

Operating Frequency: 50/60 Hz

Operating Humidity: 5 to 95% RH

Operating Altitude: 0 to 10,000 ft

Operating Vibration: 0.1 g

Operating Shock: 10 g

Operating Seismicity: 0.1 g

Operating Electromagnetic Interference: 100 V/m

Operating Electromagnetic Compatibility: 100 V/m

Operating ESD: 100 V

Operating Surge: 100 V

Operating Inrush Current: 100 mA

Operating Power Consumption: 100 mW

Operating Power Factor: 0.9

Operating Efficiency: 90%

Operating Reliability: 100,000 hours

Operating Mean Time Between Failures: 100,000 hours

Operating Mean Time To Repair: 10 minutes

Operating Total Cost of Ownership: \$100

Operating Return on Investment: 100%

Operating Payback Period: 10 months

Operating Net Present Value: \$100

Operating Internal Rate of Return: 100%

Operating Profitability Index: 1.0

Operating Break-Even Point: 10 months

Operating Sensitivity Analysis: 10%

Operating Scenario Analysis: 10%

Operating Monte Carlo Simulation: 10%

Operating Risk Assessment: 10%

Operating Compliance: 10%

Operating Certification: 10%

Operating Accreditation: 10%

Operating Registration: 10%

Operating Licensing: 10%

Operating Insurance: 10%

Operating Bonding: 10%

Operating Surety: 10%

Operating Guaranty: 10%

Operating Fidelity: 10%

Operating Indemnity: 10%

Operating Surety Bond: 10%

Operating Performance Bond: 10%

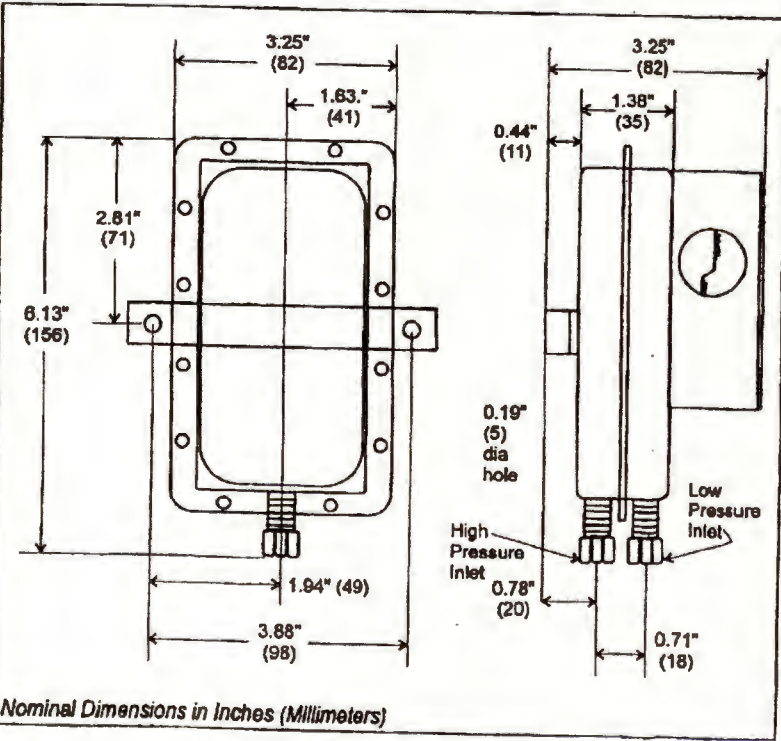

Nominal Dimensions in Inches (Millimeters)

Mounting: Rack or Panel Mount with the diaphragm in any orientation.
 Set Point Range: 0.05 to 12.0 w.c.
 Electrical Rating: 20 w.c.
 Field Adjustment Range: 0.05 to 12.0 w.c.
 Field Adjustment Range: 0.05 to 12.0 w.c.
 Approximate Accuracy: ± 0.02 w.c.
 Pressure: 0.05 to 12.0 w.c.
 Material: 304 Stainless Steel
 Weight: 1.0 lb.
 Operating Temperature Range: -40 to 150 °F
 Operating Pressure Range: 0.05 to 12.0 w.c.
 Operating Voltage: 24 VDC
 Operating Current: 10 mA
 Operating Frequency: 50/60 Hz
 Operating Humidity: 5 to 95% RH
 Operating Altitude: 0 to 10,000 ft
 Operating Vibration: 0.1 g
 Operating Shock: 10 g
 Operating Seismicity: 0.1 g
 Operating ESD: 100 V
 Operating Surge: 100 V
 Operating Inrush Current: 100 mA
 Operating Power Consumption: 100 mW
 Operating Power Factor: 0.9
 Operating Efficiency: 90%
 Operating Reliability: 100,000 hours
 Operating Mean Time Between Failures: 100,000 hours
 Operating Mean Time To Repair: 10 minutes
 Operating Total Cost of Ownership: \$100
 Operating Return on Investment: 100%
 Operating Payback Period: 10 months
 Operating Net Present Value: \$100
 Operating Internal Rate of Return: 100%
 Operating Profitability Index: 1.0
 Operating Break-Even Point: 10 months
 Operating Sensitivity Analysis: 10%
 Operating Scenario Analysis: 10%
 Operating Monte Carlo Simulation: 10%
 Operating Risk Assessment: 10%
 Operating Compliance: 10%
 Operating Certification: 10%
 Operating Accreditation: 10%
 Operating Registration: 10%
 Operating Licensing: 10%
 Operating Insurance: 10%
 Operating Bonding: 10%
 Operating Surety: 10%
 Operating Guaranty: 10%
 Operating Fidelity: 10%
 Operating Indemnity: 10%
 Operating Surety Bond: 10%
 Operating Performance Bond: 10%