

# RG&E

ROCHESTER GAS & ELECTRIC CORPORATION  
89 East Avenue  
Rochester, New York 14649

## INTERIM REMEDIAL MEASURE

# WORK PLAN

FOR TAR WELL REMOVAL  
AT THE EAST STATION  
FORMER MANUFACTURED GAS PLANT SITE  
City of Rochester, Monroe County, New York

VCA Index #: B-8-0535-98-07  
Site #: V000358-8

October 8 2004

Prepared By:

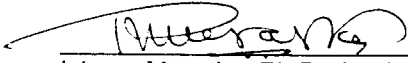
  
Ishwar Murarka, Ph.D., Ish Inc.  
Project Manager

Prepared By:

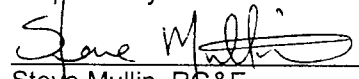
  
Steve Mullin, RG&E  
Project Manager  
Environmental Affairs

Approved By:

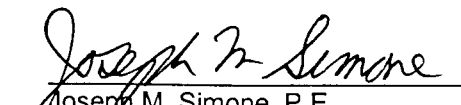
  
Joseph M. Simone, P.E.  
Site Investigation and Remediation Program Manager  
NYSEG and RG&E

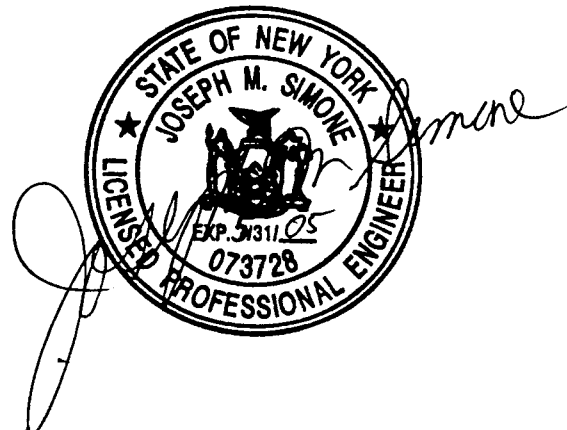

**Table of Contents**

Section	Page
List of Acronyms Referred to in the Document .....	iii
1.0 INTRODUCTION .....	1
1.1 Site Location and Description .....	1
1.2 Site History .....	1
1.3 Nature of Potential MGP Residues .....	2
1.4 Previous Investigations Previous Investigations and Reports Commissioned by RG&E .....	2
1.5 Information Collected During RG&E Commissioned Previous Investigations at the Former Gas Holder/Tar Well Location .....	3
2.0 PROJECT OBJECTIVE .....	4
3.0 ORGANIZATIONAL STRUCTURE AND RESPONSIBILITY .....	5
4.0 Work Plan .....	7
4.0.1 Definitions of Manufactured Gas Plant Site Materials .....	7
4.0.1.1 Manufactured Gas Plant Site Residue .....	7
4.0.1.2 Coal Tar .....	7
4.0.1.3 Tarry Waste .....	7
4.0.1.4 Coal Tar Soil .....	7
4.0.2 Pre-Remediation Sampling and Analysis .....	8
4.0.3 Cleanup Objectives .....	8
4.0.4 Disposal Protocol .....	8
4.0.4.1 Subsurface Fill .....	9
4.0.4.2 RCRA Non-hazardous Waste .....	9
4.0.4.3 Conditionally Exempt MGP Remediation Waste .....	9
4.0.4.4 RCRA Hazardous Waste .....	9
4.0.5 Confirmation Sampling Requirements .....	13
4.1 Site Setup .....	13
4.1.1 Utility Notification .....	13
4.1.2 Construction Office Trailer .....	13
4.1.3 Exclusion Zone .....	13
4.1.4 Contamination Reduction Zone .....	13
4.1.4.1 Equipment Contamination Reduction Pad .....	14
4.1.4.2 Personnel Contamination Reduction Area .....	14
4.1.4.3 Preparation of Stockpile Management Area (If Required) .....	14
4.1.5 Support Zone .....	14
4.1.6 Erosion and Sedimentation Control .....	14
4.2 Mobilization .....	15
4.3 Work Activities .....	15
4.4 Groundwater, Stormwater, and Wastewater Management .....	16
4.5 Construction Equipment, Vehicles and Tools Decontamination .....	16
4.6 Waste Transportation and Disposal .....	17
4.7 Contingency Plan .....	17
4.8 Site Restoration .....	17
4.9 Documentation of Site Activities .....	18
4.9.1 Daily Logbook .....	18
4.9.2 Master Sample Log .....	18
4.9.3 Chain-of-Custody Record .....	18
4.9.4 Waybills .....	18
4.10 Demobilization .....	18
4.11 Project Schedule .....	19
4.12 Permits .....	19
5.0 AIR-QUALITY MONITORING PLAN .....	20
5.1 Overview .....	20
5.2 Community Air-Monitoring Program .....	20
5.2.1 Overview .....	20
5.2.2 Real-Time Air Monitoring – Volatile Organic Compounds .....	21
5.2.3 Speciated Real-Time Air Monitoring – BTEX .....	22
5.2.4 Odor Monitoring Plan .....	23
5.2.5 Real-Time Air Monitoring – Total Suspended Particulates .....	23
5.2.6 Documentation of Air Quality Monitoring .....	24
5.2.7 Vapor Emission Response Plan .....	25
5.2.8 Major Vapor Emission Response Plan .....	26
6.0 SAMPLING AND ANALYSIS PLAN .....	27
6.1 Quality Assurance/Quality Control Requirements Data .....	27
Quality Objectives .....	27
6.2 Soil Sampling and Analyses Plan .....	28
6.2.1 Soil Sampling Field Protocols .....	28

6.2.1.1	Soil Sampling Field Procedures .....	28
6.2.1.2	Soil Sampling Field Equipment List .....	28
6.2.2	Confirmation Soil Sampling and Analysis Plan .....	29
6.2.2.1	Sampling Plan Rationale .....	29
6.2.2.2	Laboratory Analytical Protocols .....	29
6.2.2.3	Soil Sampling Protocol .....	29
6.2.3	Pre-remediation In Situ Sampling and Analysis or Waste Characterization/Site Characterization .....	30
6.2.3.1	Pre-remediation In Situ Rationale .....	30
6.2.3.2	Laboratory Analytical Protocols .....	30
6.2.4	Roll-off Container/Area of Contamination Soil Sampling and Analysis Plan for Waste Characterization .....	30
6.2.4.1	Roll-off Container/Area of Contamination Sampling Rational .....	30
6.2.4.2	Laboratory Analytical Protocols .....	31
6.2.4.3	Soil Sampling Protocol .....	31
6.3	Waste water Sampling and Analyses Plan .....	31
6.3.1	Sampling Plan Rationale .....	31
6.3.2	Laboratory Analytical Protocols .....	31
6.3.3	Wastewater Sampling Protocol .....	31
6.3.4	Wastewater Field Sampling Procedures .....	32
6.3.5	Wastewater Sampling Field Equipment List .....	32
7.0	HEALTH and SAFETY PLAN .....	33

**Tables**

4-1	Sample TCLP Benzene Analyte and Limit .....	11
4-2	Sample Analytes and Action Limits .....	11
4-3	Reactive Cyanide and Reactive Sulfide (Reactivity) .....	11
4-4	Sample TCLP Analytes and Limits .....	11
4-5	Polycyclic Aromatic Hydrocarbon (PAH) .....	12
5-1	DAR-1 (Air Guide-1) Short Term Guidance Concentrations (SGC) .....	23
6-1	Environmental Sampling Media and Objectives .....	27

**Appendices**

A	Pre-Remediation In Situ Sampling & Analysis
B	Citizen Participation Plan
C	Construction Quality Assurance Plan
D	Quality Assurance Project Plan
E	Transportation of Solid and/or Liquid Material
F	Contingency Plan
G	Organization Structure
H	Project Schedule
I	Vapor Emission Response Plan
J	BioSolve® Product Information
K	Figures, Boring Logs, Sanborn Maps
L	NYSDEC Comments, RG&E Responses, DEC Approval Letter

List of Acronyms Referred to in the Document

ACGIH	American Congress of Government Industrial Hygienists
AU	Administrative Law Judge
ANSI	American National Standards Institute
AQMP	Air-Quality Monitoring Program ASP - analytical service protocol
ASTM	American Society for Testing and Materials
AWQC	Ambient Water Quality Criteria
BCDOH	Broome County Department of Health
BTEX	benzene, toluene, ethylbenzene and xylenes
BTU	British thermal unit
cPAH	Carcinogenic Polycyclic Aromatic Hydrocarbons
C	Centigrade
CERCLA	Comprehensive Environmental Response, Compensation, and Liability Act
CFR	Code of Federal Regulations
CLP	Contract Laboratory Protocol
COC	Chain-of-Custody
CPP	Citizen Participation Plan
CPR	cardiopulmonary resuscitation
CQAP	Construction Quality Assurance Plan
CRZ	Contamination Reduction Zone
CTS	coal tar soils
DEC	Department of Environmental Conservation
DI	deionized
ECL	Environmental Conservation Law
ECRP	Equipment Contamination Reduction Pad
EI	Edison Electric Institute
ELAP	Environmental Laboratory Approval Program
EMS	Emergency Medical Services
EPA	Environmental Protection Agency
EPRI	Electric Power Research Institute
EZ	Exclusion Zone
F	Fahrenheit
FS	feasibility study
GC	gas chromatograph
GCS-DN	gas chromatograph station downwind
GCS-UP	gas chromatograph station upwind
GPS	ground positioning satellite
HASP	Health and Safety Plan
HEPA	high efficiency particulate air
HSM	Health & Safety Manager
IARC	International Agency for Research on Cancer
ID	identification
IDLH	immediately dangerous to life
IRMs	Work Plan
Kg	kilogram
L	liter
LGAC	liquid-phase granular activated carbon
mg	milligram
MGP	manufactured gas plant
MMBTU	million British thermal units
MSDS	material safety data sheet
NAPL	non-aqueous phase liquid
NCP	National Contingency Plan
NIOSH	National Institute for Occupational Safety and Health
NYCRR	New York Codes, Rules and Regulations
NYSDEC	New York State Department of Environmental Conservation

NYSDOH	New York State Department of Health
NYSDOT	New York State Department of Transportation
NYSEG	New York State Electric & Gas Corporation
OSHA	Occupational Safety and Health Act or Administration
PAHs	polycyclic aromatic hydrocarbons
PC	personal computer
PCBs	polychlorinated biphenyls
PCRA	Personnel Contamination Reduction Area
PEC	Project Emergency Officer
PEL	permissible exposure limits
PHSC	Project Health and Safety Coordinator
PID	photo ionization detector
POTW	Public Owned Treatment Works
PM	Project Manager
ppb	part per billion
PPE	personal protective equipment
ppm	parts per million
PRPs	Potentially Responsible Parties
PSA	preliminary site assessment
QA	quality assurance
QAPP	Quality Assurance Project Plan
QA/QC	quality assurance/quality control
QC	quality control
O&M	operation and maintenance
RCRA	Resource Conservation and Recovery Act
RGE	Rochester Gas & Electric Corporation
RI	Remedial Investigation
RI/FS	remedial investigation/feasibility study
ROD	record of decision
ROW	right-of-way
SAP	Sampling and Analysis Plan
SCGs	Standards, Criteria, and Guidance
SGC	short-term guideline concentrations
SHSO	Site Health & Safety Officer
SPL	sound pressure level
SSO	Site Safety Officer
STEL	short-term exposure limits
SVOCs	semivolatile organic compounds
SW	solid waste
SZ	Support Zone
I & A	time and activity
TAGM	technical and administrative guidance memorandum
TCLP	toxicity characteristic leachate procedure
TLVs	threshold limit values
TPAH	total polycyclic aromatic hydrocarbons
UFPO	Underground Facility Protection Organization
USEPA	United States Environmental Protection Agency
VOCs	volatile organic compounds
VOA	volatile organic analysis
WBG	wet bulb globe temperature

## 1.0 INTRODUCTION

This IRM Work Plan (*Work Plan*) describes the excavation and off-site disposal of the former gasholder / tar well at the East Station former manufactured gas plant site located at 86 Smith Street in the City of Rochester, Monroe County, New York. This IRM focuses on the excavation of the former gasholder foundation, associated connective piping, and visible tarry waste immediately adjacent to the outside of the tar well foundation. This project is being proposed in accordance with the Voluntary Cleanup Agreement (Index No. B8-0535-98-07) between Rochester Gas & Electric Corporation (RG&E) and the New York State Department of Environmental Conservation (NYSDEC).

This *Work Plan* describes the techniques to be utilized for the sampling, community air monitoring, excavation, material handling, waste characterization, transportation and disposal of manufactured gas plant residues excavated from the tar well area. This *Work Plan* will be performed upon approval and under the oversight of the NYSDEC and the New York State Department of Health (NYSDOH).

### 1.1 Site Location and Description

The East Station former manufactured gas plant site is located in the City of Rochester, Monroe County, New York (Figure 1). The site area is approximately 13.4 acres and is currently bound on the north and northeast by property owned by Bausch and Lomb, on the west by the Genesee River, to the south by the Bausch Street Bridge and to the east by Suntru Street (Figure 2). The site proper is owned by RG&E and currently there are 3 buildings on the northern portion of the site and 1 storage building near the center of the site and a fenced-off high pressure gas main and pressure regulator station. The northern portion of the site is paved and the remainder is mostly covered with mixed vegetation.

### 1.2 Site History

A coal carbonization MGP facility was constructed at the East Station site in 1872. The plant consisted of a single building housing the gas retorts and 1 gas holder. Two gas holders were added between 1888 and 1892 and buildings and equipment were also added around that time. A 1892 Sanborn map indicates that the original gas holder in the southeast corner of the site was being used to store gas at that time. A 1900 Rochester Plat map indicates that the same structure was used for tar storage (labeled "tar tank"). Also a carbureted water gas (CWG) plant was added to the site between 1892 and 1900. Copies of selected Sanborn maps are included in Appendix K to this work plan.

Coal-Gas produced using the CWG process was initiated at East Station circa 1900, and by 1913, the majority of the gas produced at the facility was from CWG. Historical maps up until 1910 show a gasholder illustrated on the 1892 Sanborn map (currently referred to as the tar well) being present. However, the tar well is not shown on a 1911 Sanborn Fire Insurance Map, suggesting its use was discontinued around that time (Morrison-Knudsen, 1986). Thus, based on the historical records, the same structure, referred to as the tar tank or tar well, was believed to have been used to store tar from about the mid-1890's until sometime before 1911. During this time, tar generated in both the coal

carbonization plant and the CWG plant is speculated to have been placed in the tar well.

The East Station gas manufacturing operations nearly ceased in 1917 when a new MGP was constructed at the West station location, across the river from East Station and most of the gas production was carried out at this new plant. The gas produced at West Station was purified at East Station after it crossed the river through a piping system. In fact, historical documents indicated that from the mid 1920's until gas production was stopped in the 1950's at the West station, East Station was used primarily to purify the gas produced at West station, except when gas was needed for meeting peak demand.

Additional historical detail can be found in the reports referenced in Section 1.4.

### **1.3 Nature of Potential MGP Residues**

The nature of the waste expected to be encountered during this project will include two classes. The first class is coal tar soils and debris, a mixture of soil contaminated by coal tar, which contains various concentrations of polycyclic aromatic hydrocarbons (PAHs), volatile organic compounds (VOCs) and potentially some heavy metals. These soils are typically a non-hazardous waste as determined by applicable testing methods defined by the Resource Conservation Recovery Act (RCRA) and the State regulations. The second class would include Conditionally Exempt Manufactured Gas Plant Remediation Waste (per NYSDEC - Technical and Administrated Guidance Memorandum TAGM 4061, Management of Coal Tar Wastes and Coal Tar Contaminated soils and Sediments from Former Manufactured Gas Plants). These materials typically contain 10% or more polycyclic aromatic hydrocarbons (PAHs) and volatile organic compounds (VOCs).

The excavated materials will be tested by applicable test methods to determine their classification as non-hazardous or conditionally exempt wastes under the state and federal regulations. The final treatment and disposal or reuse will conform to the determined classification.

### **1.4 Previous Investigations and Reports Commissioned by RG&E**

Three environmental site investigations, one Focused Feasibility Study (FFS), and an Executive Summary Report were commissioned by RG&E between 1992 and 2003 for use to develop strategies for the remediation of the East Station site to the extent practicable. These reports were submitted to the Department for informational purposes and have neither been formally reviewed nor approved by the Department. The first RG&E commissioned site investigation was performed by Atlantic Environmental in 1992. The second RG&E commissioned site investigation was a Focused Remedial Investigation (FRI) performed by Ish Inc. and META Environmental (META) in 1998. An addendum to the FRI was then completed in 1999 by Ish Inc. and META. The 1998 and 1999 FRI activities were summarized in a report dated April, 2000 and was submitted by RG&E to the Department with an application to perform additional environmental studies in the states Voluntary Clean-up Program. Similarly RG&E commissioned a FFS for the screening of remediation alternatives for selected areas of the East Station, and was completed by Ish Inc. and META in 2001. The RG&E commissioned FFS report was neither approved nor sanctioned by the Department and is not intended to limit consideration of potentially

applicable remedial options at the site. In October 2003 an Executive Summary Report that summarized the investigations completed through 2003 was prepared by Ish Inc. and provided to the NYSDEC as requested.

The NYSDEC approved *Work Plan* will be placed in document repositories as identified in the Citizen Participation Plan located in Appendix B. The RG&E commissioned but not reviewed or approved referenced documents will be provided upon request.

### **1.5 Information Collected During RG&E Commissioned Previous Investigations at the Former Gas Holder / Tar Well Location**

Soil borings, monitoring wells, and test pits were completed during the RG&E commissioned environmental studies in 1998/1999 and are discussed in detail in the April, 2000 FRI Report. The information obtained from the subsurface studies in the area of the tar well confirmed the diameter of the tar well foundation to be approximately 83.5 feet. The sidewalls of the foundation were confirmed to consist of masonry brick approximately 3' thick, and the top of the walls are located between 7-10 feet below grade surface (BGS). The tar well has a convex bottom constructed of masonry brick and is located between 16.5' to 25' BGS and appears to be situated on top of the underlying bedrock. Figures, soil boring, well construction, and test pit logs pertinent to the investigations completed in the area of the former gas holder / tar well that are in the April, 2000 FRI are included in Appendix K of this *Work Plan*.

The previously completed subsurface investigations commissioned by RG&E in the area of the former gas holder / tar well indicate that material above the tar well consists primarily of fill that does not exhibit signs of coal tar NAPL and the soil below the top of the foundation elevation consists of fill impacted with varying amounts of staining, tarry-soil, and tar described as being thick, viscous, and taffy-like. The bottom 1 to 2.5-foot zone of the tar well was reported to have a thick, taffy-like tar layer.



## 2.0 PROJECT OBJECTIVE

The overall objective of this IRM is “to eliminate coal tar NAPL from the tar well area at the East Station former MGP site.” This objective will be met by excavating, removing, and disposing off-site the former gasholder/tar well inclusive of its contents, foundation, connective piping (if present), and DNAPL containing material immediately adjacent to the holder/tar well structure extending to a limited distance of 20 feet outside the tar well structure. Numerical cleanup objectives will not be used during this IRM since the project goal is to remove coal tar NAPL and document the limit of excavation for the MGP site related compounds. Confirmation sampling will be carried out to document the nature of residual impacted material at the limits of the excavation. This IRM is a part of a phased approach to remediate the East Station site to the extent practicable. Therefore residual contamination outside the excavation area will be subject to future remedial considerations. This approach is consistent with discussions during a conference call between representatives of RG&E and the Department on July 1, 2004. Media impacted with contaminants of concern (COC) beyond the stated distance will be evaluated for removal in the field at the time of the IRM activities, and if not addressed at that time will be addressed as part of a site wide remedy or other remedial action.

### 3.0 ORGANIZATIONAL STRUCTURE AND RESPONSIBILITY

RG&E and New York State regulatory agencies will participate jointly in this IRM at the East Station former manufactured gas plant site. RG&E will retain qualified vendors/contractors to implement this *Work Plan* (see Organization Structure in Appendix G). Approval of this *Work Plan* by the NYSDEC will be secured prior to commencing tar well excavation activities. NYSDEC personnel are anticipated to be on-site periodically for purposes of general program oversight. RG&E will be responsible for coordinating and managing the vendors/contractors and arranging for proper disposal of remediation wastes. The vendors/contractors will be responsible for the on-site construction operations including: excavation safety; construction personnel health and safety; implementation of contingency plans for odor control; management of waste water and waste-handling operations; maintenance of Site controls (i.e., run-off, run-on); the construction, excavation, and material handling activities associated with the remedial action; soil sampling program associated with the remedial action; community air monitoring; documentation of the extent of the removal action, and report preparation.

Communication with regulatory agencies and with members of the surrounding community will be managed by RG&E. The plan for sharing project information with the community is described in the *Citizen Participation Plan for the East Station Former Manufactured Gas Plant Site Tar Well Contents Removal IRM Work Plan* included in Appendix B.

Key personnel and their assigned responsibilities for implementation of the remedial action include:

#### RG&E:

Mr. Dan Kennedy: Project Coordinator & Lead Contact  
RG&E  
89 East Avenue  
Rochester, New York 14649  
Phone:(585) 724-8386  
Cellular Phone: (585) 315-0950  
E-mail:Daniel\_Kennedy@rge.com

#### Project Managers

Ishwar Murarka Ph.D.  
Ish Inc.  
690 W. Fremont Avenue, Suite 3  
Sunnyvale, CA 94087  
Phone: (408) 720-0474  
Cellular: (408) 892-3233  
Email: [ishinc@pacbell.net](mailto:ishinc@pacbell.net)

Mr. Steve Mullin  
RG&E  
89 East Avenue  
Rochester, New York 14649  
Phone: (585) 771-4556  
Cellular Phone: (585) 315-0079  
E-mail: [Steve\\_Mullin@rge.com](mailto:Steve_Mullin@rge.com)

Mr. Joseph M. Simone, P.E.: Site Investigation and Remediation Program  
Manager  
NYSEG and RG&E  
James A. Carrigg Center, 18 Link Drive, P.O. Box 5224  
Binghamton, New York 13902  
Phone:(607) 762-7498  
Cellular Phone: (607) 427-7498  
E-mail: [jmsimone@nyseg.com](mailto:jmsimone@nyseg.com)

**NYSDEC:** Mr. Salvatore Priore, P.E.: Project Manager  
NYSDEC, 11th Floor  
625 Broadway  
Albany, New York 12233-7013  
Phone: (518) 402-9665  
E-mail: [sfpriore@gw.dec.state.ny.us](mailto:sfpriore@gw.dec.state.ny.us)

**NYSDOH:** Community Health & Safety Oversight  
Mrs. Charlotte M. Bethoney  
Bureau of Environmental Exposure Investigation  
New York State Department of Health  
Flanigan Square, Room 300  
547 River Street  
Troy, New York 12180-2216  
Phone: (518) 402-7860  
Email: [cmb18@health.state.ny.us](mailto:cmb18@health.state.ny.us)

## 4.0 Work Plan

This *Work Plan* includes a chronological description of anticipated project activities. There is a section that contains the figures referred to in the text of this Work Plan. There are several appendices included in this work plan. These appendices are: pre-remediation in-situ sampling and analysis plan (Appendix A); citizen participation plan (Appendix B); construction quality assurance plan (Appendix C); quality assurance project plan (Appendix D); transportation of solid and/or liquid waste plan (Appendix E); contingency plan (Appendix F); conceptual organization structure (Appendix G); Project Schedule (Appendix H); site vapor emission response diagram (Appendix I); Biosolve® Product Information (Appendix J); Appendix K containing a compilation of figures and soil/well/test pit logs from previous reports and selected sanborn maps; and NYSDEC and RG&E comment and response letters and NYSDEC IRM *Work Plan* approval letter (Appendix L).

Actual project experiences pertinent to excavation/removal action (i.e., community air monitoring, noise, dust control, etc.) from previous remediation efforts at other manufactured gas plant sites, have been used as guidance to prepare the procedures for this project and to minimize potential impacts to the adjoining community.

Work will be conducted so that impact (i.e., traffic, noise, odors, etc.) to the public is minimized, to the extent practicable. Hours of construction operations will not begin prior to 7 a.m. or continue after 7 p.m., Monday through Friday. Work on the weekend will be undertaken as necessary to accommodate businesses and meet the project target completion schedule. The following sections describe the procedures to be used for remedial activities.

### 4.0.1 Definitions of Manufactured Gas Plant Site Materials

**4.0.1.1 *Manufactured Gas Plant Site Residue*** - Material that is contaminated with waste from the former manufactured gas plant.

**4.0.1.2 *Coal Tar*** - Free phase tar.

**4.0.1.3 *Tarry Waste*** - Grossly contaminated soil, with visible tar as NAPL present. For purposes of this *Work Plan*, includes soil containing over 5,000 ppm total PAH's.

**4.0.1.4 *Coal Tar Soil*** - Soil that exhibits evidence of coal tar staining, but no visible tar NAPL. For purposes of this *Work Plan*, includes soil containing 500 ppm – 5,000 ppm total PAH. Soils excavated which cannot be reused, as subsurface fill will also be disposed as coal tar soil.

#### **4.0.2 Pre-remediation Sampling and Analysis**

As part of this IRM, an in situ sampling and analysis plan (shown in Appendix A) will be implemented within the proposed excavation area around the former gasholder / tar well to collect and analyze samples to segregate soils into three categories described below. Soils falling in the category of reusable material may be utilized for subsurface backfill when the total PAH concentrations are less than 500 mg/Kg. This sampling event will be conducted in accordance with the *Pre-Remediation In Situ Sampling & Analysis Work Plan for Tar Well Removal at the East Station Former Manufactured Gas Plant Site*, see Appendix A. The analytical results for the 17 PAHs generated from the soil samples will be tabulated as individual PAH (both non-carcinogenic and carcinogenic), total PAH (PAH<sub>T</sub>) and as total carcinogenic PAH (cPAH<sub>T</sub>).

The results of the sampling and analysis will be used to designate the excavated soil into three categories.

- *Conditionally Exempt Manufactured Gas Plant Remediation Waste* - per NYSDEC -Technical and administrated Guidance Memorandum TAGM 4061, Management of Coal Tar Wastes and Coal Tar Contaminated Soils and Sediment from Former Manufactured Gas Plants.
- *Non-hazardous Waste* - CTS which is below the TCLP limits and reactivity limits. However, during excavation, tarry waste will be segregated out from non-hazardous waste, as described in Section 4.0.5.
- *Reusable Material* – Soil which has no visible evidence of NAPL and has been sampled and analyzed for total PAHs and the results show total PAH to be less than 500 mg/Kg.

#### **4.0.3 Cleanup Objectives**

The overall objective of this IRM (as stated in Section 2.0) is to remove the former gasholder / tar well to prevent coal tar containing material within and around it from being a potential source of mobile tar to the environment. Numerical cleanup objectives will not be used during this project since the project objective is to remove coal tar from within and immediately adjacent to the foundation of the former gasholder / tar well and to document the excavation limits (sidewall and bottom of the foundation). Confirmatory samples will be collected in a sufficient quantity to adequately document the concentration levels at the limit of the excavation. The sampling will be conducted in accordance with Section 6.2.2. The Confirmation sampling results will be evaluated as part of the future Remedial Investigation to be performed on the East Station Former Manufactured Gas Plant Site.

#### **4.0.4 Disposal Protocol**

Pre-remediation in-situ soil samples will be collected and analyzed in accordance with *Pre-Remediation In Situ Sampling & Analysis Work Plan for the East Station Former Manufactured Gas Plant Site Tar Well Contents Removal IRM Work Plan* (Appendix A).

During excavation ex-situ soil samples may be collected and analyzed in accordance with Section 6.2.4 of this *Work Plan*. Based on the analytical results, soils will be handled according to the following criteria:

#### 4.0.4.1 Subsurface Fill:

The pre-characterization sampling and analysis data are expected to provide a reliable basis for the classification of the excavated material for potential reuse or for treatment and disposal. RG&E will use the DEC recommended level of less than 500 mg/Kg total PAHs value for reuse as backfill. The results of samples collected from the stockpiled soil that is segregated for reuse will be provided to the DEC/DOH for review prior to reuse for backfilling. The analytical results for the 17 PAHs generated from the soil samples will be tabulated as individual PAH (both non-carcinogenic and carcinogenic), total PAH (PAH<sub>T</sub>) and as total carcinogenic PAH (cPAH<sub>T</sub>).

If the analytical results of the pre-remediation in-situ soil samples or if during excavation ex-situ soil samples indicate that the analytes listed in Table 4-1, Table 4-2, Table 4-3, Table 4-4, and Table 4-5 are within their specified limits and if during excavation this soil has no evidence of coal tar, then its respective soil will be reused as subsurface fill within the excavation without the need for additional sampling and analysis. If, during excavation coal tar stained soil is encountered, then this soil may be stockpiled, sampled ex-situ and analyzed in accordance with Section 6.2.4 of this *Work Plan*. If the analytical results of the ex-situ samples are within the limits specified in Table 4-5, RG&E will provide information to the NYSDEC for acceptance prior to placing respective soil as subsurface fill within the excavation. If the analytical results of the ex situ samples are not favorable, then the respective soil will be sent to a permitted off-site disposal facility.

#### 4.0.4.2 RCRA Non-hazardous Waste:

If the analytical results of the pre-remediation in-situ soil samples or if during excavation ex-situ soil samples indicate that the analytes listed in Table 4-1, Table 4-2, Table 4-3 and Table 4-4 are within their specified limits, then the respective soil will be sent to either (1) a RCRA Subtitle D landfill; or (2) a thermal treatment facility permitted to accept it.

#### 4.0.4.3 Conditionally Exempt MGP Remediation Waste:

If the analytical results of the pre-remediation in-situ soil samples or if during excavation ex-situ soil samples indicate that the analytes listed in Table 4-2, Table 4-3, and Table 4-4 are within their specified limits but fail to meet the TCLP limit for benzene as specified in Table 4-1, then its respective soil may be managed as a RCRA conditionally exempt waste and sent to a thermal treatment facility permitted to accept it. Based on the benzene concentration levels, the waste material may require mixing/treatment with on-site soil, or other additives such as flyash, quicklime, carbon fines or other material suitable to reduce benzene concentrations to the levels acceptable to the waste disposal facility (i.e., thermal treatment facility). The mixing will be in accordance with the intent of TAGM 4061.

#### 4.0.4.4 RCRA Hazardous Waste:

If the analytical results of the pre-remediation in-situ soil samples or if during excavation ex-situ soil samples indicate that any analyte listed in Table 4-1, Table 4-2, Table 4-3, and

Table 4-4 exceeds its specified limit, then its respective soil will be sent to RCRA permitted facility.

TABLE 4-1 SAMPLE TCLP BENZENE ANALYTE AND LIMIT	
Tclp analyte	Regulatory limite (mg/L:) [6NYCRR Part 371]
Benzene	0.5

TABLE 4-2 SAMPLE ANALYTES AND ACTION LIMITS REACTIVE CYANIDE AND REACTIVE SULFIDE (REACTIVITY)	
ANALYTE	US EPA ACTION LIMIT (MG/Kg)
Reactive Cyanide	250
Reactive Sulfide	500

TABLE 4-3 SAMPLE ANALYTES AND ACTION LIMITS OTHER RCRA CHARACTERISTICS, LANDFILL REQUIREMENTS, and REQUIREMENTS FOR CONDITIONALLY EXEMPT MGP WASTE	
ANALYTE	LIMIT
PCBs (total)	50 mg/Kg
Corrosity (pH)	Non-Corrosive ([H must be >2 or <12.5)
Ignitability	Must be non-ignitable
Percent Sulfur	Must be <3.5%

TABLE 4-4 SAMPLE TCLP ANALYTES AND LIMITS	
TCLP ANALYTE	REGULATORY LIMIT (mg/L))
Arsenic	5.0
Barium	100.0
Cadmium	1.0
Carbon tetrachloride	0.5
Chlorobenzene	0.03
Chlorofom	6.0
Chromium	5.0
Cresols (total of o,m,p)	200.0
2,4-D	10.0
1,4-Dichlorobenzene	7.5
1,2-Dichloroethane	0.5
1,1-Dichloroethylene	0.7
2,4-Dinitro toluene	0.13
Endrin	0.02
Heptachlor	0.008
Hexachlorobenzene	0.13
Hexachlorobutadiene	0.5
Lead	5.0
Lindane	0.4



<b>TABLE 4-4 SAMPLE TCLP ANALYTES AND LIMITS</b>	
<b>TCLP ANALYTE</b>	<b>REGULATORY LIMIT (mg/L)</b>
Mercury	0.2
Methoxychlor	10.0
Meththyl ethyl ketone	200.0
Nitrobenzene	2.0
Pentachlorophenol	100.0
Pyridine	5.0
Selenium	1.0
Silver	5.0
Silvex	1.0
Tertrachloroethylene	0.7
Toxaphene	0.5
Trichloroethylene	0.5
2,4,5-Trichlorophenol	400.0
2,4,6-Trichlorophenol	2.0
Vinyl chloride	0.2

<b>TABLE 4-5 POLYCYCLIC AROMATIC HYDROCARBONS (PAH) TOTAL PAHs SHALL NOT EXCEED 500 mg/kg</b>	
<b>PARAMETER</b>	
Naphthalene	
2-Methylnaphthalene	
Acenaphthene	
Acenaphthylene	
Fluorene	
Phenanthrene	
Anthracene	
Fluoranthene	
Dibenzofuran	
Pyrene	
Benzo (A) Anthracene*	
Chrysene*	
Benzo (B) Fluoranthene*	
Benzo (K) Fluoranthene*	
Benzo (A) Pyrene*	
Indeno (1,2,3, CD) Pyrene*	
Dibenzo (A<H) Anthracene*	
Benzo (G,H,I) Perylene	
*Carcinogenic PAHs (cPAH)	

#### **4.0.5 Confirmation Sampling Requirements**

This proposed IRM focuses on the removal of the gas holder/tar well so that DNAPL/coal tar material in this structure is eliminated from the IRM area. Subsequent RG&E actions will be devoted to developing and undertaking, in a phased manner, additional investigation and remedial actions as approved by the NYSDEC. Confirmatory samples will be taken and appropriately measured and documented and the footprint of the excavations and soil removal areas will be surveyed. Procedures for confirmation soil sampling are presented in Section 6.2.1 of this *Work Plan*.

### **4.1 Site Set Up**

#### **4.1.1 Utility Notification**

Prior to construction activities, Dig Safely New York will be notified, and on-site underground utilities will be marked in the field.

#### **4.1.2 Construction Office Trailer**

An on-site construction office trailer will be utilized as office space by RG&E, NYSDEC and RG&E's environmental consultant. A second trailer may be present and utilized by the remediation contractor. Electric, potable water and portable toilets will be available for project personnel. The office trailer will also be used for on-site record storage, personal protective equipment, monitoring equipment, first aid location, and sample preparation and storage. In addition, the trailer can also be used for project and safety meetings, project office tasks, and changing area.

#### **4.1.3 Exclusion Zone**

The work area Exclusion Zone, which is the active work area immediate to the excavation, may change daily as the excavation progresses. Orange fence and/or yellow caution tape fastened to tee post will be used to delineate the perimeter of the Exclusion Zone (see Figure 3). The Exclusion Zone includes the area inside the waste transporter's trailer or roll off container.

#### **4.1.4 Contamination Reduction Zone**

The work area Contamination Reduction Zone, which is the area immediately outside the Exclusion Zone, will be used as a primary decontamination area for equipment and personnel. The Contamination Reduction Zone includes the truck loading area. Orange construction fence and/or yellow caution tape, and/or an alternative suitable material will be used to delineate the perimeter of the Contamination Reduction Zone. At a minimum the Contamination Reduction Zone will be an area three feet outside of the Exclusion Zone (see Figure 3).

#### **4.1.4.1 Equipment Contamination Reduction Pad**

An equipment contamination reduction pad, with a minimum size of 20 feet X 40 feet, will be constructed and maintained at the site. The interior of the pad will be sloped to an internal sump so that the wash water and sediment can be collected and removed for disposal. A spray washer will be maintained to clean vehicles and equipment should impacted media adhere to them. A submersible pump will be placed in the sump to transfer the wastewater via hose to frac tank. At the completion of this IRM, the decon pad will be cleaned, and removed if warranted (note, RG&E will be evaluating the installation of a decon pad that can remain in place for multiple use/projects).

RG&E will solicit input from the selected vendors to ensure the decon pad is constructed sufficient for the equipment needed for the project.

#### **4.1.4.2 Personnel Contamination Reduction Area**

A personnel contamination reduction area will be constructed and maintained inside the Contamination Reduction Zone. As a minimum, 6-mil polyethylene sheet will be placed on the ground. Stage 1 will contain a boot wash tub with solution of detergent, water and a long handle brush. Next will be additional boot wash tub containing rinse water and a long handle brush. A 55-gallon barrel (or other appropriate container) lined with a 6-mil polyethylene bag will also be available for disposing Tyvek® suits, gloves, paper hand towels, etc. Stage 2 will contain a hand wash tub with a solution of detergent and water. Next will be additional hand wash tub containing rinse water. Waterless hand cleaners maybe used to replace the hand wash tubs. Paper hand towels will also be available in this area.

#### **4.1.4.3 Preparation of Stockpile Management Area (If Required)**

Stockpile management area will be prepared for stockpiling excavated impacted soil, should it be needed. The area(s) will be prepared so that soil will be placed on, and covered with plastic, and the ground surface will be slightly sloped so that any moisture that may drain from the soil can be collected and transferred to the appropriate container for treatment and/or disposal. The staging area will be appropriately bermed to contain the soil/moisture.

#### **4.1.5 Support Zone**

The Support Zone is the area where project support can be rendered without contact with contamination. This area is located outside the Contaminated Reduction Zone, see Figure 4.

#### **4.1.6 Erosion and Sedimentation Control**

Silt fence and/or earth berm will be placed along the perimeter of the work area. RG&E may direct contractor to install additional erosion and sedimentation controls (i.e., Straw / hay

bales) during construction should it be needed.

## 4.2 Mobilization

As part of the mobilization activities, labor, construction equipment, materials, and sanitary facilities will initially be mobilized to the Site to prepare for remedial action activities. Several general site preparation activities will be performed before intrusive soil excavation activities are initiated. The various components associated with mobilization and site preparation activities are illustrated on Figure 4. Equipment and mode of operation will be described in further detail in the following sections.

## 4.3 Work Activities

Remedial activities undertaken during the IRM will be completed in accordance with the *Construction Quality Assurance Plan for Activities at the East Station Former Manufactured Gas Plant Site Tar Well Removal IRM Work Plan* (Appendix C). Workers will be required to have current training (proof by a training certificate) that complies with the Occupational Safety and Health Administration's (OSHA's), "Hazardous Waste Operations and Emergency Response" (29 CFR 1910.120). Personnel that may infrequently visit the site (e.g. delivery personnel, etc.) that do not have current HAZWOPER training will not be allowed to go beyond the Support Zone.

Personnel who work and/or visit the site will be required to sign in and out (including date and time) each time they enter/leave the site. A sign in/out sheet will be in the on-site office trailer.

Conceptually, this IRM will be accomplished by first removing about 10 feet of soil on top of the former tar well sidewall foundation. This excavation of the surface soils may extend 20' beyond (or around) each side of the footprint of the tar well foundation so that access to the interior of the tar well can be safely obtained. The top cover soil removed (or excavated) during this process may be stockpiled on-site for use as backfill if the pre-sampling results satisfies the criteria for use as backfill or may be disposed of off-site. After the top 10 feet of soil/fill material has been removed, excavation within the footprint of the foundation will be carried out.

The stability of the excavated sidewalls will be continuously monitored while implementing the remedial action. In the event that a particular area becomes impractical or unsafe for continued excavation (even after sloping and/or shelving the soil), then RG&E will document the presence of visible NAPL, if any, and the concentrations of MGP residuals contained in the subsurface at that particular location by utilizing the documentation sampling criteria described in Section 6.2.1.

Limited dewatering is anticipated as the excavation approaches approximately 8' from the bottom of the foundation due to groundwater infiltration into the excavation, with a limited volume of water due to surface runoff. If it becomes necessary, groundwater may be removed during excavation and transferred to wastewater storage tanks (per Section 4.4 Groundwater, Stormwater and Wastewater Management). Groundwater is anticipated to be approximately 15' (+/-) BGS. The collected/removed wastewater may be treated on-site for

discharge to POTW or to the river in accordance with all applicable discharge requirements. Alternatively the collected wastewater may be transported offsite and disposed in compliance with all applicable regulatory standards.

Odors, dust or fugitive vapors which could potentially emanate from remedial activities will be actively controlled by misting the working area with BIO SOLVE® and or water. The BIOSOLVE® (see Appendix J for product information) will be applied using a pressure washer. If required, a worker will be available for dedicated operation of this equipment. In addition, inactive portions of the stockpile and inactive areas of the excavation will be covered with polyethylene sheeting to help minimize odors and/or emissions.

Polyethylene sheeting may be draped over the loading side of dump trailers to protect against spillage during loading. Care will be exercised when loading trucks not to spill material on the outside of the dump trailers. Prior to leaving the loading area, each truck will be visually inspected (i.e., box sidewall, box tailgate, and tires, etc.) and cleaned with brushes or will be cleaned or washed on the equipment Contamination Reduction Pad (see Section 4.5). Remedial workers will reposition the tarp bars over the loads. The driver will cover the trailer with a tarp while inside the soil loading area. **Drivers will not be allowed to walk over loads.**

#### 4.4 Groundwater, Stormwater and Wastewater Management

Based on information known about the site conditions at this time, significant groundwater or waste water isn't expected to be generated requiring treatment and disposal. RG&E, however, will be prepared to store waste water in frac tanks for offsite disposal or may employ an onsite water treatment/pre-treatment system for discharge to the nearby river or Monroe County Sewer system. Further details will be developed during the final preparations of the IRM implementation plans.

RG&E will employ various techniques to reduce amount of surface water entering into open excavations. RG&E will have sandbags, hay bales and siltation fencing readily available to construct berms around the excavations when and if the need arises. RG&E will make a good faith effort to control rain water entering the excavation in order to accomplish the goals of the *Work Plan*.

Water pumped from the excavations and wastewater generated during equipment decontamination will be transferred to wastewater storage tanks (i.e., frac tanks) as needed. RG&E will not allow groundwater to spill out of the excavation area during backfilling activities. If necessary, this water will be transferred to the wastewater storage tanks. The water in the storage tanks will be sampled and characterized in accordance with the acceptance requirements of the facility permitted to accept the wastewater. When the sample results are received and the final disposal options are determined, RG&E will provide the information to NYSDEC prior to start of off-site transport and disposal. The wastewater will be transferred into a tank truck and transported off-site for disposal at a properly permitted facility.

#### 4.5 Construction Equipment, Vehicles and Tools Decontamination

The tires, tracks, undercarriages, and excavation buckets of construction equipment

(excavator, wheel loaders, dozer, etc.) and tools which enter the Exclusion Zone will be decontaminated at the Equipment Contamination Reduction Pad. Decontamination procedures include the physical/mechanical removal of soil, etc., including high-pressure washing. If tarry waste is encountered during excavation the equipment will be decontaminated before excavating non hazardous soil. At a minimum, this would include decontaminating the excavation bucket.

#### 4.6 Waste Transportation and Disposal

The transportation of soil will be accomplished by a transportation contractor in accordance with the specification for the Transportation of Solid/or Liquid Materials (see Appendix E). Truck drivers leaving the site must have either a Hazardous Waste Manifest or a Non-hazardous Solid Waste Manifest signed by RG&E or its representative, and the driver.

Trucks transporting coal tar contaminated hazardous waste or conditionally exempt MGP remediation waste will have the entire box (to top of side boards) lined with polyethylene sheets per RG&E's discretion. Trucks will have water tight tailgates, which have a gasket between the box and tailgate.

The Remedial Contractor workers will reposition the tarp bars over the waste material. **Drivers will not be allowed to walk over waste material.**

#### 4.7 Contingency Plan

*A Contingency Plan for Activities Associated with the East Station Former Manufactured Gas Plant Site Tar Well Removal IRM Work Plan (Appendix F) has been developed to address spills and temporary stop work.*

#### 4.8 Site Restoration

Upon completion of the remedial action, restoration of the site will be undertaken as follows:

- RG&E will collect and analyze appropriate number of samples from the excavated soils and upon approval by the Department will reuse (i.e., chemical analysis results showing less than 500 mg/Kg of PAHs) the approved material for backfilling. RG&E will also reuse recycled crushed concrete (generally < 2" diameter) to backfill the excavation. Recycled "crushed concrete", to be used as backfill, is currently on-site. The material is the remnants of the aboveground portions of a building that was demolished in 2000 on RG&E owned property located at 84 Andrews Street, Rochester. As suggested by the Department, RG&E will collect and analyze three composite samples from the crushed concrete stockpile material for VOCs and SVOCs using the NYSDEC approved analytical methods. This sampling and analysis work is planned for completion during the implementation of the in-situ sampling and analysis plan. These analytical data will provide documentation of the unimpacted nature of this recycled material. The backfill will be placed in lifts and compacted as necessary.

- Remove and dispose of materials used to prepare the equipment contamination reduction pad (if needed), personnel contamination reduction area, siltation fencing and earth berm.
- Waste material generated during site restoration will be characterized and disposed of in accordance with applicable regulations. Liners, polyethylene sheeting used to cover materials and personal protective equipment will also be characterized and disposed of appropriately.
- Site will be graded to allow surface water to runoff.

## **4.9 Documentation of Site Activities**

### **4.9.1 Daily Logbook**

A designated logbook will be used to document daily on-site activities. The daily logbook will be kept in the field office until completion of the excavation portion of the project.

### **4.9.2 Master Sample Log**

A laboratory notebook will remain in the field office to record every sample collected. The field technician will log in all samples collected and those sent to the off-site analytical laboratory. Waybill numbers will be logged at the end of each day.

### **4.9.3 Chain-of-Custody Record**

A Chain-of-Custody form will document custody of all samples from the field to the laboratory.

### **4.9.4 Waybills**

A waybill receipt will be obtained at the time of accepted sample shipment by Federal Express or courier and will be attached to the Master Sample Log.

## **4.10 Demobilization**

Equipment, materials, construction debris, and supplies will be demobilized from the site at the conclusion of the excavation portion of the project.

#### **4.11 Project Schedule**

A DRAFT project schedule is included in Appendix H. A final project schedule will be provided upon DEC's approval of this *Work Plan* and procurement of the vendors/contractors needed to implement the *Work Plan*.

#### **4.12 Permits**

NYSDEC Waste Transporter permits (6NYCRR Part 364) will be required by the Transportation Contractor for the vehicles to be used for transportation of waste as described in Section 4.6.



## 5.0 AIR-QUALITY MONITORING PLAN

### 5.1 Overview

The objective of this Air-Quality Monitoring Program is to provide direct measurement of volatile organic compounds and total suspended particulates (0.1 to 10 microns), which could potentially be released during excavation, handling, and transportation of manufactured gas plant residues at the site. The air-quality monitoring program consists of a community air-monitoring to determine the levels of volatile organic compounds and total suspended particulates at the perimeter of the Work Area and the site boundary.

This Air-Quality Monitoring Program meets or exceeds the criteria and guidance provided in the *New York State Department of Health Generic Community Air Monitoring Plan*. The provisions include real-time air monitoring for volatile organic compounds (VOCs) and particulates (i.e., dust) at the downwind perimeter of work area. Real-time air monitoring and speciated real-time data will be used to guide appropriate action to reduce/minimize air emissions to acceptable levels. A *Vapor Emission Response Plan diagram for the East Station Former Manufactured Gas Plant Site Tar Well Removal IRM Work Plan* (see Appendix I) has been developed as a guide to help to address exceedances of acceptable levels.

### 5.2 Community Air-Monitoring Program

#### 5.2.1 Overview

A community air monitoring program will be implemented during the IRM project to provide direct measurement of volatile organic compounds and total suspended particulate which may be released during excavation and handling of the former manufactured gas plant residues.

This air monitoring program was established to address the following objectives:

- To insure concentrations of volatile organic compounds (VOCs) and total suspended particulate are minimized to protect human health and the environment.
- To provide an early warning system so engineering controls can be enacted to prevent exceedences in action levels.
- To measure and document the concentrations of volatile organic compounds, speciated BTEX (benzene, toluene, ethylbenzene and xylene) and total suspended particulate for determining compliance with the established air monitoring limits.

The community air monitoring effort is intended to be a discrete program, which will be implemented during IRM activities that involve disturbance or handling of impacted soil.

The community air monitoring will include collection of real time air quality data, through out the duration of excavation activities and will include measurements at upwind, down wind and nearest receptor locations. Wind direction will be determined using a weather vane or equivalent meteorological equipment/devices.

## 5.2.2 Real-Time Air Monitoring - Volatile Organic Compounds

The total volatile organic compounds (VOCs) monitoring will be accomplished using a total volatile organic analyzer equipped with a photo ionization detector (PID) using a 10.2 eV lamp. Each day the analyzer will be calibrated to benzene with a 10 ppm isobutylene air standard. The volatile organic analyzer will be capable of calculating a 15-minute running average of the measured volatile organic compounds (VOCs) concentrations. The 15-minute averages will be used to monitor air quality and will be recorded through out the day.

Real-Time volatile organic compounds (VOCs) monitoring will be initiated one day prior to any excavation or soil handling activities. In addition a daily up wind measurement will be taken at the start of each work day, periodically throughout the day, and immediately following any changes in wind direction. These measurements will be used for establishing base line emissions due to natural and anthropogenic sources. The baseline value will be added to the air monitoring limits to compensate for the existing ambient conditions (i.e. VOC limit of 5 ppm + 1.2 ppm upwind = 6.2 ppm limit).

The downwind total volatile organic compounds (VOCs) monitoring will operate continuously and include the downwind locations for the work area and site perimeter. The nearest receptor (irregardless of its relationship to wind) will be an additional monitoring location if it is closer than the down wind site perimeter location. Readings at each location will be accomplished by pointing the intake tube of the instrument toward the likely emission source, generally at the height of 3 feet above grade. The instrument will measure concentrations continuously and calculate four 15-minute averages per hour through out the day. Each 15 minute average will be recorded on log sheets along with the date, time, sampling location, wind direction and weather conditions, or electronically stored in a database. A hard copy of the data will be maintained on site.

Based on data published by OSHA (Occupational Safety and Health Administration), ACGIH (American Congress of Government Industrial Hygienists) and NIOSH (National Institute for Occupational Safety and Health) a short-term air quality action level of 5 ppm for total volatile organic compounds (VOCs) has been established for air emissions action level at site perimeter. RG&E will be use an action level of 5 ppm above the existing ambient conditions (background) at the work area. Engineering control measures will be initiated for VOC levels greater than 5 ppm at the work zone. If actions to control total VOC emissions are not effective and concentrations exceed 5 ppm (above background), then excavation and waste handling activities will be halted and actions will be initiated as specified under the *Vapor Emission Response Plan* (Section 5.3.7). Concurrently a portable gas chromatography (GC) will be used to determine speciated BTEX (benzene, toluene, ethylbenzene and xylenes) levels at the location of the exceedance (to insure benzene levels do not exceed 1.0 ppm).

The 5 ppm action level (above background) at the site perimeter is based on an estimated concentration for benzene, which is one of the volatile organic compounds (VOCs) compounds included in the volatile organic analyzer reading. Since the volatile organic

## 5.0 AIR-QUALITY MONITORING PLAN

### 5.1 Overview

The objective of this Air-Quality Monitoring Program is to provide direct measurement of volatile organic compounds and total suspended particulates (0.1 to 10 microns), which could potentially be released during excavation, handling, and transportation of manufactured gas plant residues at the site. The air-quality monitoring program consists of a community air-monitoring to determine the levels of volatile organic compounds and total suspended particulates at the perimeter of the Work Area and the site boundary.

This Air-Quality Monitoring Program meets or exceeds the criteria and guidance provided in the *New York State Department of Health Generic Community Air Monitoring Plan*. The provisions include real-time air monitoring for volatile organic compounds (VOCs) and particulates (i.e., dust) at the downwind perimeter of work area. Real-time air monitoring and speciated real-time data will be used to guide appropriate action to reduce/minimize air emissions to acceptable levels. A *Vapor Emission Response Plan diagram for the East Station Former Manufactured Gas Plant Site Tar Well Removal IRM Work Plan* (see Appendix I) has been developed as a guide to help to address exceedances of acceptable levels.

### 5.2 Community Air-Monitoring Program

#### 5.2.1 Overview

A community air monitoring program will be implemented during the IRM project to provide direct measurement of volatile organic compounds and total suspended particulate which may be released during excavation and handling of the former manufactured gas plant residues.

This air monitoring program was established to address the following objectives:

- To insure concentrations of volatile organic compounds (VOCs) and total suspended particulate are minimized to protect human health and the environment.
- To provide an early warning system so engineering controls can be enacted to prevent exceedances in action levels.
- To measure and document the concentrations of volatile organic compounds, speciated BTEX (benzene, toluene, ethylbenzene and xylene) and total suspended particulate for determining compliance with the established air monitoring limits.

The community air monitoring effort is intended to be a discrete program, which will be implemented during IRM activities that involve disturbance or handling of impacted soil.

The community air monitoring will include collection of real time air quality data, through out the duration of excavation activities and will include measurements at upwind, down wind and nearest receptor locations. Wind direction will be determined using a weather vane or equivalent meteorological equipment/devices.

## 5.2.2 Real-Time Air Monitoring - Volatile Organic Compounds

The total volatile organic compounds (VOCs) monitoring will be accomplished using a total volatile organic analyzer equipped with a photo ionization detector (PID) using a 10.2 eV lamp. Each day the analyzer will be calibrated to benzene with a 10 ppm isobutylene air standard. The volatile organic analyzer will be capable of calculating a 15-minute running average of the measured volatile organic compounds (VOCs) concentrations. The 15-minute averages will be used to monitor air quality and will be recorded through out the day.

Real-Time volatile organic compounds (VOCs) monitoring will be initiated one day prior to any excavation or soil handling activities. In addition a daily up wind measurement will be taken at the start of each work day, periodically throughout the day, and immediately following any changes in wind direction. These measurements will be used for establishing base line emissions due to natural and anthropogenic sources. The baseline value will be added to the air monitoring limits to compensate for the existing ambient conditions (i.e. VOC limit of 5 ppm + 1.2 ppm upwind = 6.2 ppm limit).

The downwind total volatile organic compounds (VOCs) monitoring will operate continuously and include the downwind locations for the work area and site perimeter. The nearest receptor (irregardless of its relationship to wind) will be an additional monitoring location if it is closer than the down wind site perimeter location. Readings at each location will be accomplished by pointing the intake tube of the instrument toward the likely emission source, generally at the height of 3 feet above grade. The instrument will measure concentrations continuously and calculate four 15-minute averages per hour through out the day. Each 15 minute average will be recorded on log sheets along with the date, time, sampling location, wind direction and weather conditions, or electronically stored in a database. A hard copy of the data will be maintained on site.

Based on data published by OSHA (Occupational Safety and Health Administration), ACGIH (American Congress of Government Industrial Hygienists) and NIOSH (National Institute for Occupational Safety and Health) a short-term air quality action level of 5 ppm for total volatile organic compounds (VOCs) has been established for air emissions action level at site perimeter. RG&E will be use an action level of 5 ppm above the existing ambient conditions (background) at the work area. Engineering control measures will be initiated for VOC levels greater than 5 ppm at the work zone. If actions to control total VOC emissions are not effective and concentrations exceed 5 ppm (above background), then excavation and waste handling activities will be halted and actions will be initiated as specified under the *Vapor Emission Response Plan* (Section 5.3.7). Concurrently a portable gas chromatography (GC) will be used to determine speciated BTEX (benzene, toluene, ethylbenzene and xylenes) levels at the location of the exceedance (to insure benzene levels do not exceed 1.0 ppm).

The 5 ppm action level (above background) at the site perimeter is based on an estimated concentration for benzene, which is one of the volatile organic compounds (VOCs) compounds included in the volatile organic analyzer reading. Since the volatile organic

analyzer detects volatile compounds other than benzene, the 5 ppm action level is considered to be conservative.

### 5.2.3 Speciated Real-Time Air Monitoring - BTEX

To supplement the real-time volatile organic compounds (VOCs) air monitoring for the community air monitoring program, a portable gas chromatograph (GC) unit will be used to determine the concentration of the individual BTEX (benzene, toluene, ethylbenzene and xylenes) compounds. The gas chromatograph (GC) will be a Perkin-Elmer Photovac Voyager™ or equivalent. The Voyager™ equipped with a photo ionization detector can accurately determine the BTEX (benzene, toluene, ethylbenzene and xylenes) compounds with detection limits in the low ppb (parts per billion) range. The purpose in generating this data will be twofold: (1) to supplement the real time volatile organic compounds (VOCs) readings, aiding in critical path decisions to be made for the Vapor Emission Response Plan (Section 5.3.7); and (2) to monitor levels of BTEX (benzene, toluene, ethylbenzene and xylenes) during construction activities.

The Voyager™ will be calibrated daily using gas standards containing BTEX (benzene, toluene, ethylbenzene and xylenes) compounds. Calibration checks will be conducted twice daily (a.m./p.m.) with a verification gas standard containing the BTEX (benzene, toluene, ethylbenzene and xylenes) analytes. Calibration drift of greater than +/- 15% will require recalibration of the instrument. Samples will be collected in a tedlar bag over a 30-minute period and analyzed by the gas chromatograph (GC).

A minimum of two site perimeter monitoring stations, at least one upwind and one downwind, will be established based on meteorological information and will be designated as GCS-UP (Gas Chromatograph Station Upwind) and GCS-DN (Gas Chromatograph Station Downwind) respectively. One sample will be collected and analyzed at each station according to the following schedule:

- once every two hours during excavation of manufactured gas plant site contaminated soil and debris, commencing at the start of the work day continuing until excavation activities have ceased, and
- as warranted by the Vapor Emission Response Plan (Section 5.3.7)

The results of this sampling and analysis will be data logged into the Voyager™ memory and downloaded on a daily basis into a laptop PC (personal computer). The raw data will be reviewed weekly by personnel knowledgeable in gas chromatography. The results will be available as soon as possible after the data has been reviewed and copies will be maintained in the office trailer. Sample results will be compared to the short term guidance (SGC) values as published in the Division of Air Resources DAR-1 (Air-Guide-1) (See Table 5-1).

<b>Contaminant</b>	<b>SGC (ug/m<sup>3</sup>)</b>	<b>SGC (ppm)</b>
Benzene	1,300	0.41
Toluene	37,000	9.8
Ethylbenzene	54,000	12.44
Xylenes	4,300	1.0

#### **5.2.4 Odor Monitoring Plan**

The nature of the manufactured gas plant site residues sometimes generates nuisance odors during excavation and material handling. As such, an odor control and monitoring plan has been developed for the project.

A project fact sheet will be distributed to adjacent property owners explaining the remediation work to occur at the site, the potential for odors and how RG&E can be contacted. This will be distributed prior to beginning any excavation work.

If significant odor is detected by the site personnel or a complaint is received, engineering controls will be implemented as outlined in the Vapor Emission Response Plan (Section 5.3.7) to reduce odor causing emissions. As suggested by the Department, RG&E will use on-site personnel that are not in the exclusion zone to monitor the odors and determine if the odors are discernable or non-discernable. This determination will be subject to concurrence by the on-site NYSDEC representative.

The consultant selected to implement this IRM Work Plan will prepare a project specific project health and safety plan (HASP). RG&E will review the project specific HASP to ensure that it meets the minimum requirements before submitting the HASP to the NYSDEC and NYSDOH.

#### **5.2.5 Real-Time Air Monitoring - Total Suspended Particulates**

In conjunction with the real-time volatile emission monitoring, direct-reading monitoring equipment for particulate matter will be used to collect real-time airborne particulate data on an every 15 minutes basis. The instrument to be used for this sampling is a personal DataRam™ (field modified for active sampling at the site perimeter) or the Thermo Andersen ADR-1200S Ambient Particulate Monitoring System, both of which operate on the principle of light scattering, or equivalent instruments. Both units respond to particles in the size range of 0.1 to 10 micrometers and in the concentration range of 0.01 to 400 mg/m<sup>3</sup>. Particulate measurements will be based on a 30-second, time-weighted average. The *personal* DataRam™ will be calibrated daily with a filtered air sample. Recorded measurements at the upwind and downwind monitoring locations will be logged by the technician every 15 minutes. Equivalent backup real-time air monitoring equipment will be available on-site in the event of an equipment malfunction.

The *New York State Department of Health Generic Community Air Monitoring Plan* recommended action level of 0.15 mg/m<sup>3</sup> for particulate matter (above background) will be used to determine whether modifications to the site activities are required. If the action level is exceeded, monitoring of the upwind background level will commence immediately using the same portable monitor. If the site particulate measurement is greater than 0.15 mg/m<sup>3</sup> above the upwind background level, or if dust is observed leaving the work site, dust suppression techniques (i.e., misting surfaces with water or covering open piles) will be implemented to reduce the generation of fugitive dust. If the action level of 0.15 mg/m<sup>3</sup> (above background) is exceeded, the RG&E project manager and NYSDEC on-site representative will be notified. The RG&E project manager will notify the Division of Air Resources in writing within five working days in accordance with the NYSDEC Technical and Administrative Guidance Memorandum 4031 (TAGM 4031: Fugitive Dust Suppression and Particulate Monitoring Program at Inactive Hazardous Waste Sites, October 1989).

### 5.2.6 Documentation for Air Quality Monitoring

An essential part of a sampling/analytical scheme is ensuring the integrity of the sample from collection to data reporting. Sample integrity includes the possession and handling of a sample that is traceable from the time of collection, through analysis and final disposition.

**Sample Labels:** Unique sample identification codes will be assigned at the time of collection to prevent misidentification of samples. The identification codes will include the following information:

- project/name/number;
- sample location;
- date of collection;
- time of collection;
- initials of sampler;
- analytical method.

**Field Log Book:** Information pertinent to sampling will be recorded in a log book. It is imperative that sufficient information be recorded so that the sampling event can be reconstructed without reliance on the collector's memory. Information will be entered into a bound notebook and as a minimum entries will include the following:

- location of sampling point;
- sample identification code;
- sample collection date and time;
- sample methodology;
- sample analysis;
- collector's initials;

- field observations, if any; and
- field measurements, if any.

Dedicated field log books will be maintained on site to document the daily calibration of the real-time and speciated real-time air monitoring equipment.

### **5.2.7 Vapor Emission Response Plan**

The East Station Former Manufactured Gas Plant Site Vapor Emission Response Plan for the Tar Well Removal IRM Work Plan (see Appendix I for a plan flow diagram) will be triggered by either an exceedance of the 15 minute average volatile organic compounds (VOCs) concentration of 5 ppm (above background) at the work area or site perimeter or a benzene concentration of 1.0 ppm as measured at the site perimeter with the portable gas chromatograph (GC). If the Vapor Emission Response Plan is triggered excavation activities will be stopped and the following actions will be taken:

- Continue total volatile organic compounds (VOCs) monitoring at the work area and site perimeter. If the total volatile organic compounds (VOCs) level drops below 5 ppm (above background) then excavation activities can resume with the addition of engineering controls or modifications to the excavation process to minimize volatile organic compounds (VOCs) emissions. However if the volatile organic compounds (VOCs) levels persist above 5 ppm, based on continual observance of the meter, then the construction supervisor will immediately implement engineering controls such as misting the area with a vapor suppression solution of BioSolve®, covering, back filling etc. required to reduce emissions and at the same time notify the site project manager and the Project Health & Safety Coordinator.
- If the total volatile organic compounds (VOCs) levels drop below 5 ppm (above background) after the implementation of additional engineering controls at the work area and site perimeter, then the excavation activity can resume provided process and work activities were adjusted to reduce emission levels. If work stoppage was due to a high benzene level (greater than 1.0 ppm) at the site perimeter, then work will not resume until the benzene level is documented to be less than 1.0 ppm at the site perimeter.
- If the total volatile organic compounds (VOCs) levels continue to be greater than 5 ppm (above background) at the site perimeter then site activities must be discontinued. When the work is shut down, downwind air monitoring as directed by the Project Health & Safety Coordinator will be implemented to ensure that the emission does not impact the nearest residential or commercial structure at levels exceeding the project action levels specified in the CAMP.

Primary engineering controls which may be implemented to reduce emission levels include:

- adding a vapor suppression solution of BioSolve® to impacted media (application in excavated areas will be a light mist as to avoid increasing solubility of wastes leading to increased groundwater contamination)



- limiting excavation size and the surface area of exposed contaminated soil
- cover contaminated soils with polyethylene sheeting

### **5.2.8 Major Vapor Emission Response Plan**

If after the cessation of the work activities and implementation of engineering controls, benzene levels exceed 1.0 ppm or total volatile organic compounds (VOCs) levels exceed 5 ppm (above background) at the nearest receptor or at the site perimeter, then the following action will be immediately taken:

- Cover the excavated area with polyethylene sheeting or clean soil, or other actions as required
- Notify the following:
  - Mr. Salvatore Priore, P.E., with the NYSDEC at (518) 402-9665
  - Mrs. Charlotte M. Bethoney with the NYSDOH at (518) 402-7860
  - Mr. Joseph Albert with the MCDOH at (585) 274-6904
  - Rochester Police Department at 911
- Total volatile organic compounds (VOCs) levels will be monitored at the nearest downwind residential or commercial structure.
- Continuously monitor air quality until volatile organic compounds (VOCs) levels drop below 5 ppm.
- If total volatile organic compounds (VOCs) levels persist above the 5 ppm (above background), the construction supervisor, Project Health & Safety Coordinator, RG&E project manager will consult with each other and the Emergency Response agencies to determine the appropriate actions to be implemented. RG&E project management personnel have ultimate authority during major vapor emission emergencies. The NYSDEC must approve any action to continue work following such a shut down.

See Appendix I for a plan flow diagram.

**6.0 SAMPLING AND ANALYSIS PLAN**

This *Sampling and Analysis Plan* has been developed to describe the objectives and procedures for the sampling and analyses of manufactured gas plant residues, soil, and waste water that will be generated during this project. In addition, the RG&E East Station Former Manufactured Gas Plant Site Quality Assurance Project Plan for the Tar Well Removal IRM Work Plan (QAPP, Appendix D) and RG&E's *Pre-Remediation In-situ Sampling and Analysis Work Plan for Tar Well Removal IRM at East Station Former Manufactured Gas Plant Site* (Appendix A) should be consulted where specific sampling and analysis procedures and methods are referenced.

The environmental media anticipated to be sampled during the IRM project and the purpose for collecting and analyzing environmental samples, includes the following:

TABLE 6-1 ENVIRONMENTAL SAMPLING MEDIA AND OBJECTIVES	
Sampling Media	Sampling Objective
<b>Soil:</b>	
- Waste Characterization Samples	To characterize soil for proper waste disposal
- Confirmation Samples	To document residual soil quality after completion of remedial excavation
<b>Waste water:</b>	To characterize waste water to be transported and disposed of at a permitted facility

Because of the importance of community air monitoring it has been described in detail as a separate section of this *Work Plan (Air Quality Monitoring Plan, Section 5.0)*.

The following sections of this *Sampling and Analysis Plan* provide specific information regarding the rationale and methods for sampling and analyzing manufactured gas plant site residues, soil, and waste water.

**6.1 Quality Assurance/Quality Control Requirements/Data Quality Objectives**

Quality Assurance/Quality Control requirements are specified throughout the *Quality Assurance Project Plan for Activities Associated with the East Station Former Manufactured Gas Plant Site Tar Well Removal IRM Work Plan* (Appendix D). Data quality objectives are also delineated in the *Quality Assurance Project Plan* (Appendix D, Section 2).

## 6.2 Soil Sampling and Analyses Plan

### 6.2.1 Soil Sampling Field Protocols

#### 6.2.1.1 Soil Sampling Field Procedures

Samples will be placed into the appropriate containers specified in the *Quality Assurance Project Plan* (Appendix D) using decontaminated stainless steel trowels or spoons. Organic debris (i.e., leaves, twigs, bark) along with large pieces of gravel will be avoided. Sampling containers will be filled completely to avoid creating a head space where volatiles may escape. After each container is filled, the threads will be wiped clean so the cap can be threaded on without creating an air gap or damaging the threads.

Sample containers will be labeled with the following information as a minimum:

- Project Number;
- Sampling Time and Date;
- Sample Number;
- Sample Location;
- Analysis; and
- Collector's Initials.

The location, depth of sample, sample type, time of sample, and other associated data (i.e., color of the soil, odors, texture, etc.) will be documented in the field notebook when the sample is taken. Once the soil samples are collected, the samples will be maintained at 4°C until the samples are delivered off site for analyses.

Used sampling devices will be kept together, separate from clean tools, so that they can be cleaned according to appropriate decontamination and cleaning procedure as specified in the *Quality Assurance Project Plan*. At no time will a sampling device be used without full cleaning between collection of samples.

#### 6.2.1.2 Soil Sampling Field Equipment List

The following items constitute a minimum listing of required field equipment for collecting soil samples.

- chemical resistant boots, latex gloves, chemical resistant gloves and the appropriate level of personal protection for working conditions;
- appropriate sample containers;
- Teflon-coated or stainless steel sample spoons and bowls;
- wooden stakes and spray paint (highly visible);
- field notebook;
- sample bottle labels; water resistant tape; and
- ice cooler for sample storage.

## **6.2.2 Confirmation Soil Sampling and Analysis Plan**

### **6.2.2.1 Sampling Plan Rationale**

A confirmation soil sampling and analyses plan will be implemented to determine the concentration of compounds remaining at the limits of the excavation. These data will be used to determine if future remedial investigation or remedial action is necessary.

### **6.2.2.2 Laboratory Analytical Protocols**

Confirmation soil samples will be analyzed for total BTEX (benzene, toluene, ethylbenzene, and xylenes) and total polycyclic aromatic hydrocarbons (PAHs) using Environmental Protection Agency (EPA) Laboratory methods 8240 and 8270, respectively. Samples collected to verify conformance with the cleanup objectives will be subject to NYSDEC ASP (Analytical Services Protocol) Category B deliverables. Target compound list (TCL) volatile and semi-volatile compounds for post remediation confirmatory samples will be determined at a minimum rate of 1 per every group of 10 confirmatory samples or portion thereof.

The laboratory chosen for the project will be certified, and maintain certification, under the NYSDOH Environmental Laboratory Approval Program (ELAP) and NYSDOH Environmental Laboratory Approval Program (ELAP) Contract Laboratory Protocol (CLP) for analyses of solid and hazardous waste. Analytical laboratories that have experience in manufactured gas plant site projects or similar projects will be used.

### **6.2.2.3 Soil Sampling Protocol**

In the excavated areas outside the tar well foundation, confirmatory samples will be obtained at a maximum sidewall horizontal interval of 50 feet. Confirmation samples will also be collected at the bottom of the excavation if soil is present (note, the bottom of the excavation is expected to be the top of bedrock. If the bottom of the excavation is bedrock, samples from the bottom of the excavation will not be collected, and the observations of the bedrock surface documented). If soil exists at the bottom of the excavation, a 3:1 composite sample will be collected at an interval of one sample every 500 square feet. Confirmation samples will be documented by ground positioning satellite (GPS) receiver or other equivalent method.

A sample representing the first 3 to 6 inches of soil encountered will be taken from each sampling point. This means that in the case of a sidewall sample, the first 3 inches of a sample point in the sidewall will be discarded and the remaining soil at that point, to a lateral depth of approximately 6 inches, will be collected. In the case of a bottom sample, the first 3 inches of a sample point in the excavation floor will be discarded and the remaining soil at that point, to a vertical depth of approximately 6 inches, will be collected. The first 3 inches are discarded to avoid collecting soil sample at the surface of the excavation because volatile compounds at the excavation surface may have been released. Discarding the first 3 inches of soil will help to ensure that a sample representing the volatile compounds present in the excavation are more accurately profiled. The sample will

be representative of the area soil based upon visual and olfactory observations and Volatile Organic Analyzer readings.

Confirmation samples obtained from excavations extending beyond 4 feet below grade may be collected via a stainless steel remote sampler or a hydraulically-activated sampling device. A drawing depicting confirmation sample locations along with information concerning sample identifications, depth below original ground surface, and dates of collection will be maintained by the field sampling technician throughout the project.

### **6.2.3 Pre-remediation In Situ Sampling and Analysis for Waste Characterization/Site Characterization**

**6.2.3.1 Pre-remediation In Situ Sampling Rationale** (See *Pre-Remediation In Situ Sampling & Analysis Work Plan for the East Station Former Manufactured Gas Plant Site Tar Well Removal IRM Work Plan*, Appendix A, "Introduction".)

**6.2.3.2 Laboratory Analytical Protocols** (See *Pre-Remediation In Situ Sampling & Analysis Work Plan for the East Station Former Manufactured Gas Plant Site Tar Well Removal IRM Work Plan*, Appendix A, "Analytical Protocol".)

**6.2.3.3 Soil Sampling Protocol** (See *Pre-Remediation In Situ Sampling & Analysis Work Plan for the East Station Former Manufactured Gas Plant Site Tar Well Removal IRM Work Plan*, Appendix A, "Sampling Protocol".)

### **6.2.4 Roll Off Container/Area of Contamination Soil Sampling and Analysis Plan for Waste Characterization**

#### **6.2.4.1 Roll off Container/Area of Contamination Sampling Rationale**

A soil roll-off container/area of contamination sampling and analysis plan may be implemented to supplement the Pre-Remediation In Situ Sampling and Analysis Work Plan. This sampling and analysis plan is to address (1) subsurface soil characterized as RCRA non-hazardous waste by pre-remediation in situ sampling which upon excavation appears to require off-site disposal as a hazardous waste (i.e., soil that appears to be grossly contaminated with tarry waste) or (2) subsurface soil characterized as RCRA hazardous waste by pre-remediation in situ sampling which upon excavation appears to be suitable for off-site non-hazardous waste disposal (i.e., soil that appears to be clean or lightly contaminated with tarry waste). During the course of remedial excavation, subsurface soil will be examined for visual and odorous evidence of MGP contamination. If the excavated soil appears to fit either description delineated above, it may be placed in a roll-off container or stockpiled within the excavation in increments up to 200 cubic yards. Caution will be taken during segregation of waste to ensure that excavation techniques will not be used to dilute

tarry waste, which is likely to be RCRA hazardous waste. The Area of Contamination (AOC) for the East Station Former MGP Site is the former plant area, which is identified in Figure 2. Disposition of soil will be based on the criteria delineated in Section 4.0.4.

#### **6.2.4.2 Laboratory Analytical Protocols**

(See *Pre-Remediation In Situ Sampling & Analysis Work Plan for Activities Associated with the East Station Former Manufactured Gas Plant Site Tar Well Removal IRM Work Plan*, Appendix A, "Analytical Protocol", List A Analytes)

#### **6.2.4.3 Soil Sampling Protocol**

One representative composite sample comprised of at least 3 grab samples will be collected from each roll-off container or stockpile as soon as practical following excavation and submitted to the laboratory for analysis. Each sample will represent up to 200 cubic yards of soil.

### **6.3 Wastewater Sampling and Analyses Plan**

#### **6.3.1 Sampling Plan Rationale**

Wastewater resulting from dewatering of the excavation and decontamination of equipment will be generated during the IRM project. A sampling and analysis plan will be implemented to properly characterize the wastewater for disposal at a local Public Owned Treatment Works (POTW) or an alternate disposal facility permitted to accept it.

If the results of the analysis meet the limits specified by the POTW, then the wastewater will be transferred into tank trucks for transport to the POTW or be discharged into the sanitary sewer. If the wastewater is identified as material that exceeds local POTW specifications, then an alternate permitted disposal facility will be used or an on-site pretreatment/treatment system will be installed and operated for the duration of the IRM work.

#### **6.3.2 Laboratory Analytical Protocols**

Analytical requirements will be determined by a POTW or by facility permitted to accept wastewater.

#### **6.3.3 Wastewater Sampling Protocol**

As the on-site storage tank nears its capacity, a sample will be collected and analyzed for parameters specified by the local POTW or by an alternate facility permitted to accept the wastewater.

#### **6.3.4 Wastewater Field Sampling Procedures**

Wastewater will be sampled directly from each tank prior to shipment off-site. Nitrile gloves will be worn to protect the sampling person and to avoid cross contamination through handling. Wastewater will be sampled by lowering a stainless steel or disposable polyethylene bailer into the tank. The sample contents will be immediately transferred into the appropriate sized container for each analysis as specified in the *Quality Assurance Project Plan* (Appendix D). Vials for volatile analyses will be filled completely to avoid creating a head space where volatiles may escape, and must be checked to ensure that no air gap or bubbles are present.

Filled sample container must be labeled with the following information as a minimum:

- Project Number;
- Sampling Time and Date;
- Sample Number;
- Analysis; and
- Collector's Initials.

The sample chain-of-custody form will be immediately filled out and kept with the sample. The sample will be maintained at 4°C until delivered to the off-site analytical laboratory.

#### **6.3.5 Wastewater Sampling Field Equipment List:**

The following items constitute a minimum listing of required field equipment for collecting wastewater samples.

- chemical resistant gloves and appropriate level of personal protection for working;
- appropriate sample containers;
- stainless steel or disposable polyethylene bailer;
- field notebook;
- sample bottle labels; and
- chain-of-custody forms.

## 7.0 Health and Safety Plan

The consultant selected to implement this IRM Work Plan will prepare a project specific project health and safety plan (HASP). RG&E will review the project specific HASP to ensure that it meets the minimum requirements before submitting the HASP to the NYSDEC and NYSDOH.



***RG&E***

**ROCHESTER GAS & ELECTRIC CORPORATION**  
89 East Avenue  
Rochester, New York 14649

**APPENDIX A**

**PRE-REMEDICATION  
IN SITU SAMPLING & ANALYSIS  
WORK PLAN**

**ASSOCIATED WITH THE**

**EAST STATION  
FORMER MANUFACTURED GAS PLANT SITE**

**Tar Well Removal IRM Work Plan**

**City of Rochester, Monroe County, New York**  
**VCA Index #: B8-0535-98-07**  
**Site #: V000358-8**

October 8, 2004

Prepared By:  
RG&E Environmental Affairs

**TABLE OF CONTENTS**

<b>Section</b>	<b>Page</b>
1.0 INTRODUCTION .....	1
2.0 SAMPLING PROTOCOL .....	2
3.0 WASTE CHARACTERIZATION .....	5
4.0 AIR QUALITY MONITORING .....	6
5.0 ANALYTICAL PROTOCOL .....	7

**TABLES**

1 Composite Sample TCLP Analytes and Limits .....	8
2 Composite Sample Analytes and Action Limits Other RCRA Characteristics and Landfill Analytical Requirements .....	9
3 Composite Sample Analytes for ESMI .....	9
4 Composite Sample Analytes for Polycyclic Aromatic Hydrocarbons (PAHs) .....	10
5 Approximate Soil Volumes .....	11
6 Sampling Area Breakdown .....	11

**FIGURES**

Figure 1 – Aerial View of IRM Target Area - Pre-Remedial In-situ Sample Locations	3
Figure 2 – Cross Section of Tar Well Removal Area	4

## 1.0 INTRODUCTION

Rochester Gas & Electric Corporation (RG&E) is preparing to implement an interim remedial measure (IRM) to excavate, remove and dispose a former gas holder/tar well inclusive of its contents, foundation, and connective piping (if present). The IRM will include excavation of surrounding tarry waste or visibly coal tar containing soils immediately adjacent to and extending to a limited distance of 20 feet outside the tar well structure. The tar well is associated with the East Station former manufactured gas plant site, City of Rochester, Monroe County, New York. This *Pre-Remediation In Situ Sampling & Analysis Work Plan* describes the sampling and analysis efforts to be undertaken to provide waste characterization data for materials generated during the IRM.

The in-situ sampling program will utilize Geoprobe® sampling equipment to characterize approximately 15,000 cubic yards of material to be excavated and managed (this includes material inside the tar well structure, the fill material overlying the tar well foundation/structure and the material outside of the tar well limited to a distance of 20 feet.). Analytical tests will be performed on the material samples to characterize the material for proper treatment or disposal, or reuse as backfill.

RG&E and/or its environmental consultant will conduct the pre-excavation sampling of the in-place soils based on a conceptual model (as shown in Figure 2) of the impacted and un-impacted soils in the target excavation area. A drilling contractor will be retained to employ Geoprobe® Sampling equipment to obtain samples of the material targeted for excavation in the approximately 130 feet rectangular area during the IRM remediation project. The soil samples will be analyzed by a New York State Department of Health (NYSDOH) Environmental Laboratory Approval Program (ELAP) certified analytical laboratory utilizing the methods and procedures specified. Sampling and analyses will be performed in accordance with the *Quality Assurance Project Plan* in Appendix D of the IRM Work Plan. Data will be submitted to the New York State Department of Environmental Conservation (NYSDEC) and disposal facilities for review and approval prior to final disposition of the material under the determined classification.

Care will be taken to ensure that subsurface soil (investigation derived waste) is not being spread over the surface of the site. Any excess soil cuttings will be containerized for proper off-site disposal during the IRM activities.

## 2.0 SAMPLING APPROACH

The area of the East Station site targeted for excavation is shown in Figure 1 of this SAP and Figure 2 shows a conceptual cross section of the tar well removal area. This area is 130 feet long by 130 feet wide with an estimated average depth of about 24 feet to the bedrock. This area includes the former tar well, the overlying fill material above the tar well (note the top of the tar well foundation side wall is about 9 to 10 feet below the grade surface), and the surrounding tarry waste or visible coal tar DNAPL containing soils immediately adjacent to and limited to a distance of 20 feet outside of the tar well structure. The overburden fill material in the target IRM area will be excavated to lower the surface elevation for the excavation and removal of the tar well and the surrounding area to a limited distance of 20 feet.

Conceptually, three zones will be targeted for characterization sampling. As shown on Figure 2, data available from previous RG&E commissioned site investigations suggest that there are potentially three vertical zones (layers) consisting of the impacted and the un-impacted materials to be excavated during the IRM. The overburden fill material (first zone) extends to a depth of about 10 feet from current ground surface. The deeper 8 to 10 feet next layer (second zone) is expected to contain somewhat impacted soil whereas the bottom 4 to 5 feet material (third zone) is expected to contain tarry waste and visible coal tar DNAPL.

There are 15 spatial sampling points shown on Figure 1 where Geoprobe® sampling equipment with a 4-foot macro-Core sampler will be used to obtain samples across the proposed IRM target area. Sample cores will be collected until the bedrock is encountered. Each macro-Core will be opened and screened for volatile organic vapors with a total vapor analyzer equipped with a photo ionization detector (PID). A discrete sample for volatile organic compounds (VOC) analysis will be collected from the section of the sampling interval with the highest volatile organic vapor concentration, as measured with the total vapor analyzer, and/or distinct coal tar odor or discoloration. The driller will be equipped with the capability to switch over to hollow-stem auger drilling method with split spoon sampling if the Geoprobe macro-core sampling method is found not to be performing well due to the nature of the subsurface material observed during the field work.

Samples with visible coal tar will be noted, but not analyzed in each boring. Three samples covering the three target zones will be collected from each of the 15 sampling locations. One additional sample may be collected from each of the five cores within the tar well, if needed for further vertical characterization of the material in the tar well. Tables 5 and 6 provide a summary of the number of samples to be collected by each vertical zone and calculated volume of material to be excavated in each zone.

**Figure 1 Aerial View for IRM Target Area: Pre-Remedial In-Situ Sample Locations**

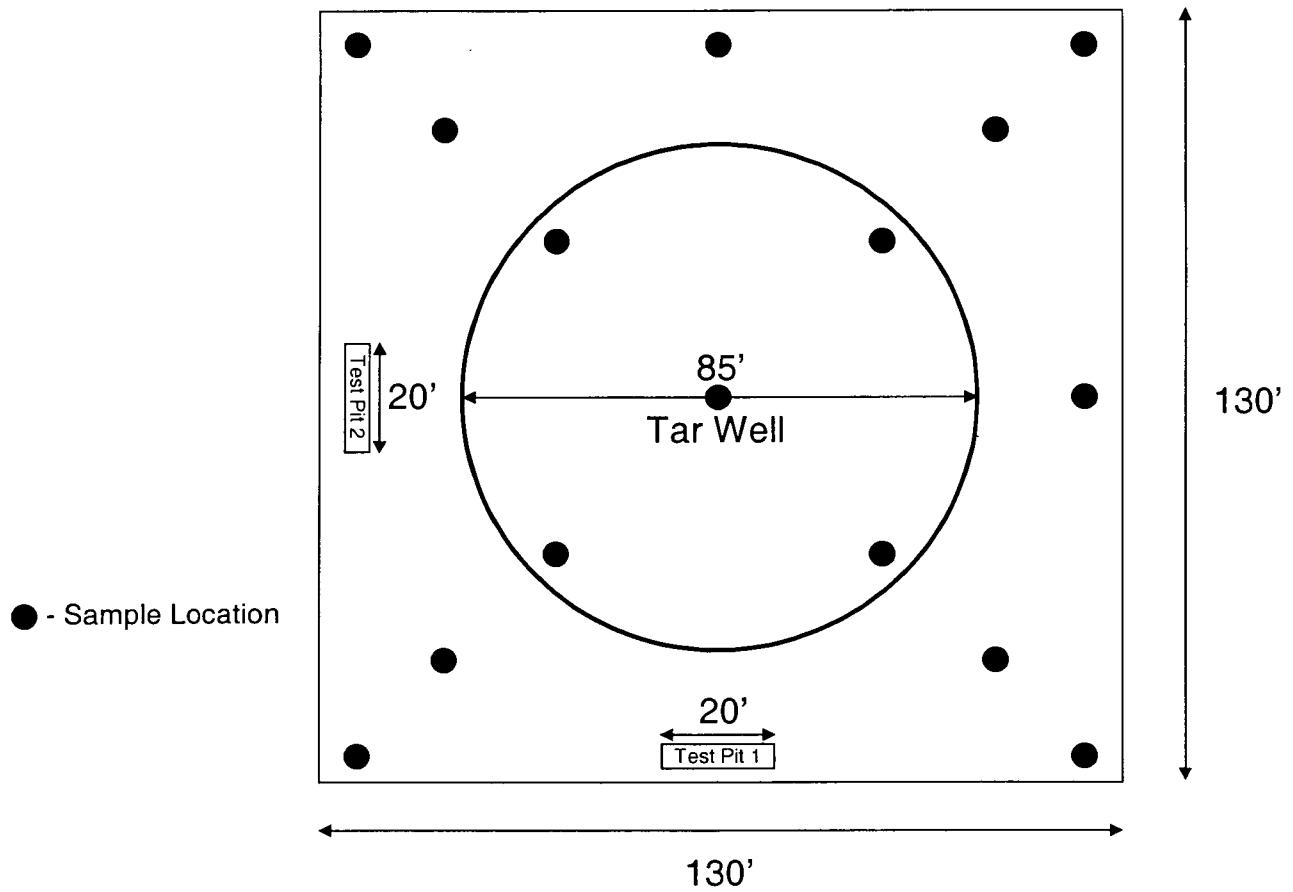

Since the designated sampling locations will undergo remedial excavation, sand or bentonite pellets will be used to seal Geoprobe® holes. Any excess materials will be containerized and disposed during the IRM activities.

**Figure 2 Cross-Section of Tar Well Removal Area (Schematic View)**

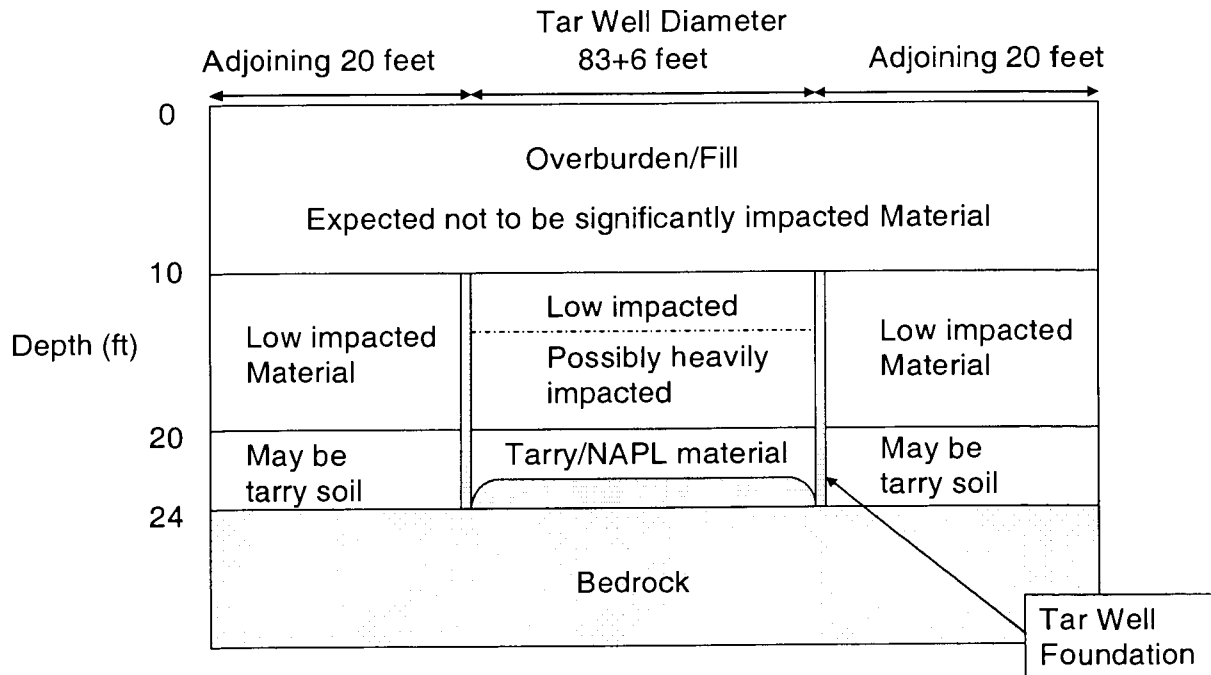

RG&E also proposes to excavate two test pits extending to the bedrock formation in the IRM excavation area. The locations of the two test pits are shown on Figure 1. Additional soil samples may be collected for analysis from the open test pits if needed. The test pits are expected to be about 20 feet long and may be about 24 feet deep. Each test pit will be allowed to remain open for about two hours before appropriate measurements are made to determine the standing water level in the test pits so that an accurate characterization is available on the groundwater table in the excavation area. The standing water in the test pits will be then pumped from the test pits with an electric pump to determine the dewatering rate and the recharge rate for developing details for water management during the IRM implementation.

As suggested by the Department, RG&E will collect three composite samples from the stockpiled recycled concrete to be used for backfilling of the excavated area. These three samples will be analyzed for VOC and SVOC content.

### **3.0 WASTE CHARACTERIZATION**

Waste characterization of the collected samples will be completed in a hierarchical manner. All 45 to 50 samples will be analyzed for VOCs and SVOCs. The data will be used to classify samples in two categories: un-impacted soils containing less than 500 mg/Kg of total PAHs, and impacted soils containing more than 500 mg/Kg of total PAHs. Samples exceeding the 500 mg/Kg total PAHs level will be composited (15 to 16 composite samples will be generated as shown in the Table 6) and further analyzed for TCLP constituents as shown on Table 1 to determine hazardous, non-hazardous or conditionally exempt waste designation. The samples of the non-hazardous material, potentially to be sent to a landfill, will be further characterized for the analytes listed in Table 2. The samples containing tarry wastes or visible coal tar DNAPL will be composited and analyzed for the analytes for ESMI as shown in Table 3.

This sampling and analysis program offers the flexibility and efficiency for regulatory classification of the excavated material as well as allowing RG&E to characterize for waste treatment and disposal management of the excavated material for complying with applicable regulatory requirements.

## 4.0 AIR QUALITY MONITORING

This air quality monitoring program will provide direct measurement of volatile organic compounds (VOCs) that are released during the in-situ sampling process. The site area is confined to the area within RG&E's East Station Site. Real time air monitoring for volatile organic vapors will commence at the start of each workday and will continue until daily sampling activities have ceased. The real time monitoring data to be collected will allow an assessment of the impact, if any, of the sampling activities on air quality.

Real time monitoring will be accomplished using a total vapor analyzer equipped with a photo ionization detector (PID), which will be calibrated daily to benzene with a 10 ppm isobutylene standard. The vapor analyzer equipped with a photo ionization detector (PID) will be capable of calculating 15-minute running average concentrations. Monitoring will be undertaken at the downwind location of the work area while macro-core samples are being collected. Upwind concentrations will be measured at the start of each work day and following a change in wind direction.

Sampling will be accomplished by pointing the intake tube of the vapor analyzer equipped with a photo ionization detector (PID) toward the emission source, generally two feet above the Geoprobe® borehole. After 15 minutes has elapsed, the calculated running average concentration of the volatile organic vapors in the air will be measured and recorded on data sheets along with time, Geoprobe® sampling location, wind direction and weather conditions.

Based on data published by the Occupational Safety and Health Administration (OSHA), the American Congress of Government Industrial Hygienists (ACGIH), and National Institute for Occupational Safety and Health (NIOSH), short-term air quality action levels have been established for air emissions control at the site perimeter. An action level for total volatiles at the site perimeter has been established at 5.0 ppm above background. If this action level is exceeded, Geoprobe® sampling activities will cease with potential sources of emissions to be contained. If odors are detected in the nearby community, despite the fact that the total volatiles are below 5 ppm action level, actions will be taken to minimize or eliminate the odors.



## 5.0 ANALYTICAL PROTOCOL

Please refer to the *Quality Assurance Project Plan* in Appendix "D" of the IRM Work Plan for specific methods where not specified)

### **List of Analytes for the characterization of the waste samples:**

Toxicity characteristic leaching procedure (TCLP) Volatiles, TCLP Semi-volatile TCLP Metals, TCLP Pesticides/Herbicides, Reactive Cyanide, Reactive Sulfide, Reactivity - Corrosivity (pH) - Ignitability, PCBs, Percent Solids, Total Petroleum Hydrocarbons (Diesel Range Organics), Total VOCs, SVOCs, Total Metals, Total Cyanide, Percent Sulfur (Tables 1,2,3 & 4)

<b>TABLE 1 (Continued on next page)</b>	
<b>COMPOSITE SAMPLE TCLP ANALYTES AND LIMITS</b>	
<b>TCLP Analyte</b>	<b>Regulatory Limit (mg/L) 6NYCRR Part 371</b>
Arsenic	5.0
Barium	100.0
Benzene	0.5
Cadmium	1.0
Carbon Tetrachloride	0.5
Chlordane	0.03
Chlorobenzene	100.0
Chloroform	6.0
Chromium	5.0
Cresols (total of o,m,p)	200.0
2,4-D	10.0
1,4-Dichlorobenzene	7.5
1,2-Dichloroethane	0.5
1,1-Dichloroethylene	0.7
2,4-Dinitrotoluene	0.13
Endrin	0.02
Heptachlor	0.008
Hexachlorobenzene	0.13
Hexachlorobutadiene	0.5
Lead	5.0
Lindane	0.4
Mercury	0.2
Methoxychlor	10.0
Methyl Ethyl Ketone	200.0
Nitrobenzene	2.0
Pentachlorophenol	100.0
Pyridine	5.0
Selenium	1.0

<b>TABLE 1 (Continued from previous page)</b>	
<b>COMPOSITE SAMPLE TCLP ANALYTES AND LIMITS</b>	
<b>TCLP Analyte</b>	<b>Regulatory Limit (mg/L) 6NYCRR Part 371</b>
Silver	5.0
Silvex	1.0
Tetrachloroethylene	0.7
Toxaphene	0.5
Trichloroethylene	0.5
2,4,5-Trichlorophenol	400.0
2,4,6-Trichlorophenol	2.0
Vinyl Chloride	0.2

<b>TABLE 2</b>	
<b>COMPOSITE SAMPLE ANALYTES AND ACTION LIMITS OTHER RCRA CHARACTERISTICS AND LANDFILL ANALYTICAL REQUIREMENTS</b>	
<b>Analyte</b>	<b>Limit</b>
Corrosivity (pH)	Non-Corrosive (pH must be > 2 or < 12.5)
Ignitability	Must be > 60 degree C
PCBs (Total)	< 50 mg/Kg
% Solids	Must be > 20%

<b>TABLE 3</b>	
<b>COMPOSITE SAMPLE ANALYTES FOR ESMI</b>	
<b>Analyte</b>	
TPH Diesel Range Organics (8015B)	
Total VOCs (8260)	
Total SVOCs (8270)	
Total Metals 14* (6010B)	
Total Cyanide (9012)	
Percent Sulfur (ASTM D129-64)	
Total Metals List: Antimony, Arsenic, Barium, Cadmium, Chromium (Total), Lead, Mercury, Nickel, Selenium, Silver, Thallium, Vanadium, Zinc	

<p align="center"><b>TABLE 4</b>  <b>COMPOSITE SAMPLE ANALYTES FOR</b>  <b>POLYCYCLIC AROMATIC HYDROCARBONS (PAHs)</b>  <b>Total PAHs Shall Not Exceed 500 ppm</b></p>	
<b>Analyte</b>	
Naphthalene	
2-Methylnaphthalene	
Acenaphthene	
Acenaphthylene	
Fluorene	
Phenanthrene	
Anthracene	
Fluoranthene	
Dibenzofuran	
Pyrene	
Benz(a)anthracene	
Chrysene	
Benzo(b)fluoranthene	
Benzo(k)fluoranthene	
Benzo(a)pyrene	
Indeno(1,2,3 cd)pyrene	
Dibenz(a,h)anthracene	
Benzo(g,h,i)perylene	

<b>TABLE 5 APPROXIMATE SOIL VOLUMES</b>	
<b>Locations</b>	<b>Approx. Soil Volume in Each of the Three Zones (Cubic Yards)</b>
Overburden Un-impacted fill zone ( approx. 16,900 sq feet by 10 feet deep)	6250
Middle impacted soil zone (approx. 16,900 sq feet by 10 feet deep)	6250
Bottom Tarry/Coal Tar DANAPL containing zone (approx. 16,900 sq. feet by 4 feet deep)	2,500

<b>TABLE 6 SAMPLING BREAKDOWN</b>						
Zone #	Approx. Area (Sq. Ft.)	Estimated Depth (Ft.)	Approx. Volume (Cu. Yds.)	# Samples Locations	# Samples Discrete	# Samples Composited
1	16,900	10	6250	15	15	5
2	16,900	10	6250	15	15-20	5-6
3	16,900	4	2500	15	15	5

***RG&E***

**ROCHESTER GAS & ELECTRIC CORPORATION**  
89 East Avenue  
Rochester, New York 14649

## **Appendix B**

# **CITIZEN PARTICIPATION PLAN**

**ASSOCIATED WITH THE**

**EAST STATION  
FORMER MANUFACTURED GAS PLANT SITE**

## **Tar Well Removal IRM**

**City of Rochester, Monroe County, New York  
VCA Index #: B8-0535-98-07  
Site #: V000358-8**

October 8, 2004

Prepared By:  
RG&E Environmental Affairs

**TABLE OF CONTENTS**

<b>Section</b>	<b>Page</b>
1.0 INTRODUCTION .....	1
2.0 BASIC SITE INFORMATION .....	1
3.0 PREVIOUS SITE INVESTIGATIONS, IRM WORK PLANS AND IRM FINAL ENGINEERING REPORTS .....	2
4.0 PROJECT DESCRIPTION .....	2
5.0 PUBLIC NOTIFICATION .....	2
6.0 DOCUMENT REPOSITORY .....	3
7.0 DESCRIPTION OF CITIZEN PARTICIPATION ACTIVITIES FOR EACH MAJOR ELEMENT OF THE REMEDIAL DESIGN WORK PLAN .....	3
8.0 ADDITIONAL INFORMATION .....	4

**ATTACHMENTS**

Figure 1                      Site Location Map

## 1.0 INTRODUCTION

This Citizen Participation Plan will detail the citizen participation activities that will be implemented for the planned Tar Well Removal IRM at the East Station former manufactured gas plant site.

*An Interim Remedial Measures Work Plan For the Tar Well Contents Removal Associated with the East Station Former Manufactured Gas Plant Site* has been developed. The proposed Interim Remedial Measures Work Plan (*Work Plan*) will involve excavation and off-site disposal of the contents of the tar well and evaluation of its foundation at the East Station former manufactured gas plant site located in the City of Rochester, Monroe County, New York, as shown on Figure 1. The *Work Plan* will be conducted according to the requirements of a Voluntary Cleanup Agreement (VCA) between RG&E and the New York State Department of Environmental Conservation (NYSDEC). The VCA is a legal document, which defines the obligations of each party for conducting site investigations and remedial actions, including IRMs.

## 2.0 BASIC SITE INFORMATION

The East Station former manufactured gas plant site is located in the City of Rochester, Monroe County, New York. The site area is approximately 13.4 acres and is currently bound on the north and northeast by property owned by Bausch and Lomb, on the west by the Genesee River, to the south by the Bausch Street Bridge and to the east by Suntru Street.

The site was used to manufacture gas from 1872 through 1917 on a regular basis, and for peaking demand from 1917 through the 1950's. Between 1917 and the mid 1950's the MGP was used primarily to purify and store gas for distribution that was produced at the West Station MGP. Between the mid 1950's and mid 1970's the East Sta plant was used as a natural gas reformulation plant in order to give the natural gas the same characteristics a manufactured gas, rendering it useable in existing equipment and appliances. The structures associated with the gas manufacturing process were removed in 1976.

Byproducts of gas manufacturing include coal tars, light oils and spent purifying materials.

Coal tars generally contain volatile organic compounds (VOCs) and polycyclic aromatic hydrocarbons (PAHs).

Purifier materials are materials (i.e. wood chips or other organic material with iron filings) used to remove impurities like hydrogen sulfide and cyanide from the gas produced by the manufactured gas plant. These materials can contain sulfides and cyanides complexed with iron.



Petroleum products were used on-site as a fuel source for the manufactured gas plant and to increase the heat content of the manufactured gas. The petroleum products used were generally a heavier fraction of the crude distillate (i.e. diesel, No. 6, bunker C, etc.).

### **3.0 Previous Investigations, Interim Remedial Measures Work Plans and Interim Remedial Measures Final Engineering Reports**

Three environmental site investigations, one Focused Feasibility Study (FFS), and an Executive Summary Report were commissioned by RG&E between 1992 and 2003. The first site investigation was performed by Atlantic Environmental in 1992. The second investigation was a Focused Remedial Investigation (FRI) performed by Ish Inc. and META Environmental (META) in 1998. An addendum to the FRI was then completed in 1999 by Ish Inc. and META. The 1998 and 1999 FRI activities were summarized in a report dated April, 2000. A FFS for the development and screening of remediation alternatives for selected areas of the East Station was subsequently completed by Ish Inc. and META in 2001. In October 2003 an Executive Summary Report that summarized the investigation completed through 2003 was prepared by Ish, Inc. The reports referenced have been previously provided to the NYSDEC.

### **4.0 PROJECT DESCRIPTION**

The overall objective is the elimination of a potential source of coal tar in the tar well. This objective will be accomplished by removing the contents of the tar well.

This *Work Plan* is targeted to be initiated during the fourth quarter of 2004 pending NYSDEC approval and securing of contractors (see project schedule in Appendix H).

### **5.0 PUBLIC NOTIFICATION**

A mailing list will be developed that will include adjacent property owners and businesses, local and State elected officials, local media, and other identified interested parties. The list will be updated to include other interested parties as they are identified throughout the project. Contact names, as noted below in Section 8, will be provided on the notifications.

## 6.0 DOCUMENT REPOSITORY

The NYSDEC approved *Work Plan* will be available for public review at the following document repositories:

- (Local document repository TBD upon approval of this *Work Plan*)
- New York State Department of Environmental Conservation  
625 Broadway  
Albany, New York  
Attn.: Salvatore Priore, P.E.  
Phone: (518) 402-9665 or 1-800-342-9296

## 7.0 DESCRIPTION OF CITIZEN PARTICIPATION ACTIVITIES FOR THE INTERIM REMEDIAL MEASURE

To facilitate the *Interim Remedial Measures* process, RG&E in cooperation with the NYSDEC and NYSDOH, will inform the public and local officials of planned remedial activities. Public participation will include, at a minimum, the following:

- Implement the public participation requirements referenced in the MSVCA (Index #: B8-0535-98-07);
- Support the NYSDEC as required in the development and distribution of Fact Sheet(s);
- Distribution of a letter and/or fact sheet prepared by RG&E to those identified on the mailing list to be developed as stated in Section 5.0 of this document and the planned remedial activities.

## 8.0 Additional Information

For additional information about this project you may contact any of the following individuals:

Mr. Steve Mullin  
Project Manger  
**RG&E**  
89 East Avenue  
Rochester, New York 14649  
Phone: (585) 771-4556  
E-mail: [Steve\\_Mullin@rge.com](mailto:Steve_Mullin@rge.com)

Mr. Daniel Kennedy  
Project Coordinator & Lead Contact  
**RG&E**  
89 East Avenue  
Rochester, New York 14649  
Phone: (585) 724-8386  
Email: [Daniel\\_Kennedy@rge.com](mailto:Daniel_Kennedy@rge.com)

Mr. Salvatore Priore  
Project Manager  
**NYSDEC**  
625 Broadway  
Albany, New York 12233-7013  
Phone: 1-800-342-9296  
or (518) 402-9665  
E-mail: [sfpriore@gw.dec.state.ny.us](mailto:sfpriore@gw.dec.state.ny.us)

Mrs. Charlotte M. Bethoney  
Community H&S Oversight  
**NYSDOH**  
Bureau of Env. Exposure Investigation  
New York State Department of Health  
Flanigan Square, Room 300  
547 River Street  
Troy, New York 12180-2216  
Phone: (518) 402-7860  
Email: [cmb18@health.state.ny.us](mailto:cmb18@health.state.ny.us)

**Figure 1  
Site Location Map**

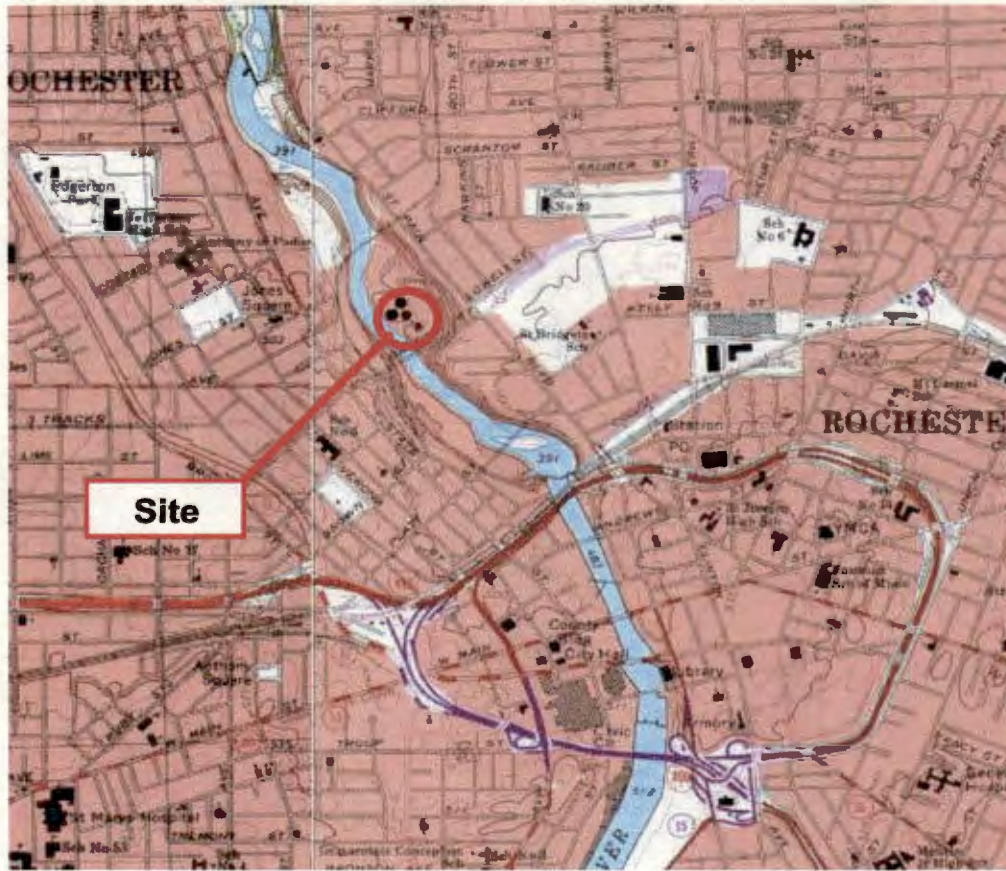

From Rochester, NY 7.5' USGS Topographic Map

0 2000  
Approximate Scale (ft)

**FIGURE 1  
Rochester Gas & Electric  
Former East Station MGP Site Location**

***RG&E***

**ROCHESTER GAS & ELECTRIC CORPORATION**  
89 East Street  
Rochester, New York 14649

## **Appendix C**

# **CONSTRUCTION QUALITY ASSURANCE PLAN**

**ASSOCIATED WITH THE  
EAST STATION  
FORMER MANUFACTURED GAS PLANT SITE**

## **Tar Well IRM Work Plan**

**City of Rochester, Monroe County, New York  
VCA Index #: B8-0535-98-07  
Site #: V000358-8**

October 8, 2004

Prepared By:  
RG&E Environmental Affairs

**TABLE OF CONTENTS**

<b>Section</b>	<b>Page</b>
1.0 INTRODUCTION .....	1
1.1 Construction Quality Assurance Plan (CQAP) Objectives .....	1
2.0 RESPONSIBILITY AND AUTHORITY.....	2
2.1 Contractor .....	2
2.2 Construction Quality Assurance Officer .....	2
2.3 Sampling Quality Assurance Officer .....	3
2.4 Construction Quality Control Representative .....	3
2.5 Sampling Representative .....	4
3.0 FIELD QUALITY CONTROL INSPECTIONS, TESTING, AND SAMPLING REQUIREMENTS.....	6
3.1 Site Preparation .....	6
3.2 Equipment Set-up .....	6
3.3 Excavation Activities .....	6
3.4 Loading of Materials for Transportation .....	6
3.5 Stockpiles of Materials .....	7
3.6 Site Restoration.....	7
4.0 DOCUMENTATION AND REPORTING REQUIREMENTS FOR CQA/CQC ACTIVITIES .....	8
4.1 Inspection Reports .....	8
4.2 Daily Field Construction Report .....	8
4.3 Photo Log.....	8
4.4 Daily Sampling Log .....	9
4.5 Variances to <i>Work Plan</i> .....	9
4.6 Final Engineering Report .....	9

## 1.0 INTRODUCTION

This *Construction Quality Assurance Plan* is designed to assure the quality of the project by monitoring, observing, documenting, and testing the processes and materials associated with the Interim Remedial Measures Work Plan (*Work Plan*) to be completed at the East Station former manufactured gas plant site, City of Rochester, Monroe County, New York. This Construction Quality Assurance Plan supplements the *Work Plan*.

### 1.1 Construction Quality Assurance Plan Objectives

The objective of this *Construction Quality Assurance Plan* is to identify and standardize measures to provide confidence that activities in the phases of the project will be completed in accordance with the *Work Plan*, applicable local, state and federal regulations and appropriate industry standards. The *Construction Quality Assurance Plan* will be implemented through inspection, sampling, testing, and review of services, workmanship, and materials. Specific objectives of this plan establish protocols and procedures for the following components:

1. **Responsibility and Authority** - The responsibility and authority of the key personnel involved in the completion of the project.
2. **Inspection and Testing Activities** - Establish the observations and tests that will be used to ensure that the construction activities for the project meet or exceed the design criteria, (i.e., *Work Plan*, and local, state and federal regulations).
3. **Sampling Strategies** - Establish responsibility for sampling activities and methods including frequency and acceptance criteria for ensuring that sampling meets criteria in the *Work Plan*, local, state and federal regulations.
4. **Documentation and Reporting** - Establish appropriate field documents (i.e., daily field construction reports, photographic log, sampling log, and variances to the *Work Plan*).

## 2.0 RESPONSIBILITY AND AUTHORITY

Responsibilities of each member of the construction project team are described below.

### 2.1 Remediation Contractor & Environmental Consultant

The contractor is responsible for coordinating field operations of the project, including coordination of subcontractors, to comply with the requirements of the *Work Plan* and permitting agencies. The Contractor is responsible for completing and submitting documentation required by the *Construction Quality Assurance Plan* and also has the authority to accept or reject the materials and workmanship of any subcontractors at the site.

The contractor is also responsible to ensure a functional construction quality control organization is active during the project and provide support for the construction quality control system to perform inspections, tests and retesting in the event of failure of any item of work, including that of the subcontractors, and to assure compliance with the contract provisions. The construction quality control system includes, but is not limited to, the inspections and tests required in the technical provisions of the *Work Plan*.

### 2.2 Construction Quality Assurance Officer: **TBD** Remediation Contractor

The responsibility of the construction quality assurance officer is to perform those activities in this *Construction Quality Assurance Plan* deemed necessary to assure the quality of construction and support quality control efforts. The construction quality assurance officer will be on-site as required during construction activities. The responsibility of the construction quality assurance officer is to ensure the quality of construction meets or exceeds that defined by the *Work Plan* and identified in the *Quality Assurance Plan*. Specific responsibilities of the construction quality assurance officer include:

- Directing and supporting the construction quality control representative inspection personnel in performing observations and tests by verifying that the data are properly recorded, validated, reduced, summarized, and inspected.
- Evaluating the construction activities and the construction quality control representative's efforts.
- Evaluating sampling activities and efforts of the sampling quality assurance officer.
- Educating construction quality control inspection personnel on construction quality control requirements and procedures .
- Scheduling and coordinating construction quality assurance inspection activities.



**2.3 Sampling Quality Assurance Officer: TBD (Env. Consultant upon vendor Selection)  
Soil Sampling and Air-Quality Manager**

The responsibility of the sampling quality assurance officer is to perform those activities in this *Construction Quality Assurance Plan*, *Work Plan* and *Quality Assurance Plan* deemed necessary to assure the quality of sampling and testing and support quality control efforts.

To avoid conflicts of interest, the sampling quality assurance is performed by an entity other than the remediation contractor, and provides assurance that all sampling efforts, for both field and laboratory analysis, meet or exceed that defined by the *Work Plan* and identified in the *Construction Quality Assurance Plan*. The sampling quality assurance officer will be on-site as required during the project. The sampling quality assurance officer will report directly to the construction quality assurance officer.

Specific responsibilities of the sampling quality assurance officer include:

- confirm that the test data are properly recorded and maintained (this may involve selecting reported results and backtracking them to the original observation and test data sheets);
- confirm that the testing equipment, personnel, and procedures do not change over time or making sure that changes do not adversely impact the inspection process; and
- confirm that regular calibration of testing equipment occurs and is properly recorded.
- Providing the construction quality control officer with up to date sampling results.

**2.4 Construction Quality Control Representative: TBD – Environmental Consultant**

A construction quality control representative is to be on the work site during the construction process, with complete authority to take action necessary to ensure compliance with the *Work Plan* as necessary to achieve quality in the constructed facility. The construction quality control representative will be the field engineer. Specific responsibilities of the construction quality control representative include:

- *Work Plan* review for clarity and completeness so that the construction activities can be effectively implemented.

- Verifying contractor's construction quality is in accordance with this *Construction Quality Assurance Plan*.
- Performing on-site inspection of the work in progress to assess compliance with the *Work Plan*.
- Prepare and log material shipping manifest for transportation of non-hazardous and Hazardous materials.
- Reporting the results of observations and tests as the work progresses, modify materials and work to comply with the *Work Plan*. This includes:
  1. Providing reports on daily field construction, material shipments, and inspection results.
  2. Review and interpretation of data sheets and reports.
  3. Identification of work that should be accepted, rejected, or uncovered for observation, or that may require special testing, inspection, or approval.
  4. Rejection of defective work and verification that corrective measures are implemented.
  5. Make observations and records that will aid in finalization of the final report.
- Reporting to the construction quality assurance officer results of all inspections including work that is not of acceptable quality of that fails to meet the *Work Plan*.
- Verifying that the equipment used in testing meets the test requirements and that the tests are conducted according to the proper standardized procedures.
- Verifying that materials are installed as specified, except where necessary field modifications were required.
- Hold daily safety tailboard meetings.
- Coordinate, lead and document project progress meetings that occur on-site during the project – frequency of meetings to be established with the NYSDEC project manager at the beginning of the field activities.

The construction quality control representative will report directly to the quality assurance officer.

**2.5 Sampling Representative:** TBD (Env. Consultant)  
Sampling Technician

A sampling representative, supplemented as necessary by additional personnel, is to be on the work site at all times during the construction process. The sampling representative

reports directly to the sampling quality assurance officer. Specific responsibility of the sampling representative include:

- Set up and operation of the weather station. Daily recording of meteorological data.
- Daily calibration and operation of real time total volatile organic compound and suspended particulate air monitoring equipment. Daily recording of real time air quality data. Informs construction supervisor and on-site New York State Department of Environmental Conservation (NYSDEC) and New York State Department of Health (NYSDOH) representatives when concentration of air contaminants approaches or exceeds action levels specified in the *Work Plan*.
- Daily calibration and operation of the portable gas chromatograph (Perkin-Elmer Voyager) per guidelines specified in the *Quality Assurance Plan* and *Work Plan*. Compiling calibration and results data into spreadsheets.
- Collection, packaging and shipment soil and water samples per guidelines specified in the *Quality Assurance Plan* and *Work Plan*. Maintaining master log of all air, water and soil samples collected. Tracking confirmation sample points and construct a map depicting confirmation sample point locations.
- Consultation with Sampling Quality Assurance Officer for technical questions, problems, considerations, or requests for supplies or equipment.
- Maintaining and organizing on-site field specialist equipment and supplies storage area.
- Performing the duties of Assistant Health & Safety Officer.

### **3.0 FIELD QUALITY CONTROL INSPECTIONS, TESTING, AND SAMPLING REQUIREMENTS**

The definable features of work identified below are described in Section 4 of the *Work Plan*. This section of this *Construction Quality Assurance Plan* describes the anticipated inspection, testing, and sampling requirements of these definable feature works.

#### **3.1 Site Preparation**

Elements of the site preparation, including clearing and grubbing will be inspected as they occur to assure compliance with the *Work Plan*.

#### **3.2 Equipment Set-up**

Materials and equipment are designed to meet specific project needs. Each delivery of materials and/or equipment will be inspected upon arrival by the construction quality control representative and stored at a designated area of the site. Equipment will be set-up per the work plan design and drawings.

#### **3.3 Excavation Activities**

Excavation activities will comply with Occupational Safety and Health Administration's (OSHA's), "Hazardous Waste Operations and Emergency Response" (29 CFR 1910.120) and Excavations (29 CFR 1926 Subpart P). Excavation activities undertaken during the *IRM* will be in accordance with the *Work Plan*. Limits of the excavation will be measured by the construction quality control representative upon completion of the excavation for documentation drawings. Confirmation Sampling is covered in a separate sampling assurance plan.

#### **3.4 Loading of Materials Transportation**

Materials will be loaded with mechanical equipment (e.g., excavator) into dump trailers for transportation to a permitted disposal facility. Polyethylene sheeting may be placed between the stockpile or excavation and the truck to retain any material spilled, when warranted. The spilled material will be added back to the excavation following completion of loading of each truck. The loading area will be visually inspected to confirm that spilled material is removed from the loading area if outside of the immediate excavation area.

### **3.5 Stockpiles of Materials**

Stockpiles will be inspected a minimum of once per day to assure that covers are in place and intact, and standing water is removed from the liner as needed. Covers will be replaced as needed to prevent precipitation from contacting the material and dust from being generated by the material.

### **3.6 Site Restoration**

Site restoration will be observed by the construction quality control representative. The excavation noted above will be backfilled as specified in the *Work Plan*, and the surface will match the existing surfacing material. Clean imported topsoil will be inspected upon arrival.

Backfilling and compacting of the excavation will be observed and documented by the construction quality control representative. Disturbed areas will be graded to match existing grades.

#### **4.0 DOCUMENTATION AND REPORTING REQUIREMENTS FOR CQAP ACTIVITIES**

The value of this *Construction Quality Assurance Plan* will be assured by proper documentation techniques. The construction quality assurance plan inspection team will be guided by data sheets, schedules and checklists. The documentation of the inspection activities will facilitate the adherence to the design documents and maintain the level of reporting required by the parties involved in the project.

##### **4.1 Inspection Reports**

In general, documentation may involve daily summary and photographic reports including sketches of a particular section or activity, inspection log, corrective measure summary, or schedule summary. Specific documentation procedures are listed in the following subsections. The construction quality control representative will ensure that one set of full sized contract drawings are marked on a daily basis to record deviations from the contract drawings, including buried or concealed structures and utilities which are revealed during the course of site work. The construction quality control representative shall initial each variation or revision. The construction quality control representative shall, upon completion of site work, certify the accuracy of the record drawings, and submit them to the project manager.

##### **4.2 Daily Field Construction Report**

The construction quality control representative shall prepare a Daily Field Construction Report identifying work force and their labor hours, location and description of work performed, lost time accidents, equipment left on job site, equipment/materials received and if applicable, submittal status, non-compliance notices received, errors and/or omission in plans and specifications, visitors to the job site, weather conditions and temperatures, and any other pertinent information.

##### **4.3 Photo Log**

The photo log is designed to document construction activities by still photos. Photo log may also be used to photographically record activities recorded in a daily construction log or an as-built sketch log. Photos will be collected by the construction quality control representative.

#### 4.4 Daily Sampling Log

The daily sampling log is designed to document all sampling activities and how they correspond to the *Work Plan*. Observations, field and/or laboratory tests will be recorded on a daily sampling log. It is important to note recorded field observations may take the form of notes, charts, sketches, or photographs. The daily sampling log will be completed by the sampling technician.

#### 4.5 Variances to *Work Plan*

Required changes to the *Work Plan* will be processed through the use of a variance log. Approval from the RG&E project manager is required to recommend a change to the *Work Plan*. An amendment to the *Work Plan* will be developed for acceptance and approval by NYSDEC and NYSDOH.

#### 4.6 Final Engineering Report

At the completion of the project the Environmental Consultant Project Manager and/or construction quality assurance officer will prepare and submit a Final Engineering Report to the NYSDEC. This report will include a summary of the Daily Field Construction Report's, Photographic Log, Sampling Log, Material Disposition Log, and Variances to *Work Plan*.

The Final Engineering Report will be signed and certified by a professional engineer that activities that comprised the *Work Plan* were performed in full accordance with NYSDEC approved *Work Plan* and the NYSDEC Voluntary Cleanup Agreement Index# B8-0535-98-07.

***RG&E***

**ROCHESTER GAS & ELECTRIC CORPORATION**  
89 East Avenue  
Rochester, New York 14649

## **Appendix D**

# **QUALITY ASSURANCE PROJECT PLAN**

**ASSOCIATED WITH THE**

**EAST STATION  
FORMER MANUFACTURED GAS PLANT SITE**

## **Tar Well Removal IRM**

**City of Rochester, Monroe County, New York  
VCA Index #: B8-0535-07  
Site #: V000358-8**

October 8, 2004

Prepared By:  
RG&E Environmental Affairs



**Table of Contents**

<b>Section</b>	<b>Page</b>
1.0 INTRODUCTION .....	1
2.0 DATA QUALITY OBJECTIVES .....	2
3.0 SAMPLE COLLECTION .....	3
3.1 Soils .....	3
3.2 Wastewater Sampling.....	3
3.3 Sampling Containers and Preservation .....	3
3.4 Sampling Holding Times.....	5
4.0 SAMPLE CUSTODY, IDENTIFICATION & TRACKING .....	7
4.1 Holding Times and Sample Transport.....	7
4.2 Chain of Custody .....	7
4.2.1 Sample Identification .....	7
4.3 Laboratory Sample Tracking.....	8
5.0 CALIBRATION PROCEDURES .....	9
6.0 ANALYTICAL PROCEDURES .....	10
6.1 Laboratory Analyses .....	10
6.2 Laboratory Selection.....	11
7.0 DATA REDUCTION VALIDATION AND REPORTING .....	12
7.1 Data Reduction .....	12
7.1.1 Field Data Collection.....	12
7.1.2 Laboratory Data Collection and Reduction .....	12
7.2 Data Review.....	12
7.3 Full Data Validation.....	12
7.4 Data Usability Summary Report (DUSR).....	13
7.5 Reporting .....	13
8.0 QUALITY CONTROL CHECKS.....	14
8.1 Field Quality Control .....	14
8.1.1 Decontamination Procedures for Confirmation Sampling .....	14
8.2 Laboratory Quality Control (QC) .....	14
9.0 PREVENTATIVE MAINTENANCE .....	15
9.1 Field Instruments and Equipment.....	15
9.2 Laboratory Instruments and Equipment.....	15
9.2.1 Instrument Maintenance .....	15
9.2.2 Equipment Monitoring.....	15
<b>TABLES</b>	
Table A – Sample Containers & Preservatives.....	4
Table B – Waste Characterization Samples.....	5
Table C – Waste Water Samples.....	6
Table D – Post Remediation Confirmatory Samples .....	6
Table E – Analytical Analytical Methods .....	10
Table F – Polycyclic Aromatic Hydrocarbon (PAH) Analyte List.....	11

## 1.0 INTRODUCTION

This *Quality Assurance Project Plan* provides a description of the sampling and laboratory procedures/protocols to be used in support of the Interim Remedial Measures Work Plan (*Work Plan*) associated with the East Station former manufactured gas plant site, City of Rochester, Monroe County, New York. The fundamental purpose of the *Quality Assurance Project Plan* is to ensure that quality analytical data will be generated to support the project in a manner consistent with the Data Quality Objectives as specified herein. This *Quality Assurance Project Plan* is designed to be used in conjunction with a New York State Department of Environmental Conservation (NYSDEC) approved *Work Plan* with regards to specific project objectives and field sampling activities. To the extent that discrepancies exist between this *Quality Assurance Project Plan* and the *Work Plan*, the *Work Plan* shall control.

## 2.0 DATA QUALITY OBJECTIVES

Data quality objectives are statements, expressed in either qualitative or quantitative terms, which address the appropriate level of data quality for a project. The quality of data generated must be suitable to support the decisions used to achieve the overall goals as delineated in the *Work Plan*. The general project data quality objectives are summarized in this section, with detailed information given throughout this *Quality Assurance Project Plan* and associated sections of the specific project *Work Plan*. The overall data quality objectives of the project are:

- To ensure that samples collected are representative of the sample population.
- To provide detection limits for the selected analytical methods, which are below the established cleanup objectives or regulatory limits, when practicable.
- To measure and document precision and accuracy using procedures established by the laboratories, the New York State Department of Health (NYSDOH) Environmental Laboratory Approval Program (ELAP) and U.S. Environmental Protection Agency (EPA) approved analytical methods.
- To ensure that soil/residues and wastewater analyses will be conducted by a NYSDOH ELAP and NYSDOH ELAP CLP certified laboratory.
- To ensure that final site verification samples (confirmatory samples) are reported with ASP Category B deliverables.

### 3.0 SAMPLE COLLECTION

#### 3.1 Soils

Soil samples will be collected as described in the appropriate sections of the *Work Plan* or the *Pre-remediation In Situ Sampling and Analysis Work Plan*. These sections describe the collection procedures, sampling equipment, locations and frequencies for the soil samples. These sections are based on the requirements for soil disposal or confirmation of excavation endpoint.

Sampling equipment will be properly disposed or decontaminated before being reused (see Section 9.1.1). Samples will be collected and placed in pre-cleaned sample containers provided by the laboratory performing the analysis. Necessary preservatives will be added to the sample containers at the laboratory prior to being shipped to the site (see Section 3.3).

Samples will be stored at 4 degrees Centigrade or cooler until delivered to, and analyzed by the laboratory. This will be accomplished by utilization of an on-site refrigerator and/or coolers with ice. (When collecting composite samples for toxicity characteristic leachate procedure (TCLP) volatile analysis, volatilization will be minimized by covering the sample compositing container and placing it within a cooler filled with ice between grab sample additions.)

#### 3.2 Wastewater Sampling

Wastewater samples will be collected as described in the appropriate sections of the *Work Plan*. These sections describe the collection procedures, sampling equipment, locations and frequencies for the wastewater samples. Samples of wastewater will be analyzed before being transported to a permitted facility for proper treatment and disposal.

Samples will be transferred directly into pre-cleaned sample collection containers, which are supplied by the laboratory performing the analyses. Necessary preservatives will be added to the sample containers at the laboratory prior to being shipped to the site (see Section 3.3).

Samples will be stored at 4 degrees Centigrade or cooler until delivered to, and analyzed by the laboratory. This will be accomplished by utilization of an on-site refrigerator and/or coolers with ice.

#### 3.3 Sample Containers and Preservatives

Sample containers and preservatives will be provided by the contracted laboratories and stored on-site in a clean and dry location. Sample containers and preservatives by matrix and analysis are listed in the table below.

**TABLE A  
 SAMPLE CONTAINERS & PRESERVATIVES**

<b>Analysis</b>	<b>Matrix</b>	<b>Container</b>	<b>Preservative</b>
TCLP Semi volatiles	Soil	500 ml glass*	4 degrees C
TCLP Metals	Soil	500 ml glass*	4 degrees C
TCLP Pesticides/Herbicides	Soil	500 ml glass*	4 degrees C
Reactive Cyanide	Soil	500 ml glass*	4 degrees C
Reactive Sulfide	Soil	500 ml glass*	4 degrees C
TCLP Volatiles	Soil	20 ml glass	4 degrees C
Total PAHs	Soil	250 ml glass	4 degrees C
Total BTEX (benzene, toluene, ethylbenzene, xylenes)	Soil	125 ml glass	4 degrees C
Total Metals	Soil	250 ml glass**	4 degrees C
Total Metals	Water	500 ml plastic	HNO <sub>3</sub> to pH < 2
Semi volatiles	Water	1000 ml amber glass	4 degrees C
Pesticides/Herbicides	Water	1000 ml amber glass	4 degrees C
Volatiles	Water	40 ml glass	4 degrees C or HCl to pH <2
Paint Filter	Water	500 ml glass	4 degrees C
Total Cyanide	Water	500 ml plastic	4 degrees C NaOH to pH >12
Percent Sulfur	Soil	250 ml glass**	4 degrees C
PCBs	Soil	500 ml glass***	4 degrees C
Ignitability	Soil	500 ml glass***	4 degrees C
BTU/lb	Soil	500 ml glass***	4 degrees C
Flashpoint	Soil	500 ml glass***	4 degrees C
Reactivity	Soil/Water	500 ml glass***	4 degrees C
Corrosivity	Soil/Water	500 ml glass***	4 degrees C
Percent Solids	Soil	500 ml glass***	4 degrees C
pH	Soil	500 ml glass***	4 degrees C

\* May be analyzed from same sample container and/or extract.  
 \*\* May be analyzed from same sample container.  
 \*\*\* May be analyzed from same sample container.  
 Note: All glass containers will be sealed with Teflon lined caps. All water samples for organic fractions will be collected in duplicate.

**3.4 Sampling Holding Times**

The following identifies samples by type and matrix and their related holding times.

<b>TABLE B WASTE CHARACTERIZATION SAMPLES</b>		
<b>Sample Type</b>	<b>Matrix</b>	<b>Holding Time*</b>
TCLP Pest./Herb.	Soil	5 days (extraction) 40 days (after extraction)
TCLP Semi volatiles	Soil	5 days (extraction) 40 days (after extraction)
TCLP Mercury	Soil	5 days (extraction) 28 days (after extraction)
TCLP Metals	Soil	180 days
TCLP Volatiles	Soil	14 days
Reactive Sulfide	Soil	7 days
Reactive Cyanide	Soil	14 days
PCBs	Soil	5 days (extraction) 40 days (after extraction)
Ignitability	Soil	N/A
Reactivity	Soil	Cyanide 14 days Sulfide 7 days
Corrosivity	Soil	2 days
Percent Solids	Soil	N/A
* Samples will be analyzed on a priority basis and reported within 10 days of collection or the maximum holding time, whichever is less.		

<b>TABLE C WASTEWATER SAMPLES</b>		
<b>Sample Type</b>	<b>Matrix</b>	<b>Holding Time*</b>
Semi volatiles	Water	5 days (extraction) 40 days (after extraction)
Metals	Water	180 days
Total Cyanide	Water	14 days
Paint Filter	Water	N/A
Reactivity	Water	Cyanide 14 days Sulfide 7 days
Corrosivity	Water	Analyze immediately
Volatiles	Water	14 days
* Samples will be analyzed on a priority basis and reported within 5 days or the maximum holding time, whichever is less.		

<b>TABLE D POST REMEDIATION CONFIRMATORY SAMPLES</b>		
<b>Sample Type</b>	<b>Matrix</b>	<b>Holding Time</b>
Total Benzene	Soil	7 days
PAHs	Soil	5 days to extraction 40 days after extraction
TCL Volatiles	Soil	7 days
TCL Semi volatiles	Soil	5 days to extraction 40 days after extraction
Total Mercury	Soil	26 days
Total Lead	Soil	26 days
1 ASP Category B deliverables required. Duplicates, matrix spike, and matrix spike duplicate samples will be collected at a rate of ten percent. 2. Samples will be analyzed on a priority basis and reported within 48 hours or the maximum holding time, whichever is less. 3. TCL volatiles and semi-volatiles will be determined at a minimum rate of 1 per every group of 10 confirmation samples or portion thereof.		

## **4.0 SAMPLE CUSTODY, IDENTIFICATION & TRACKING**

### **4.1 Holding Times and Sample Transport**

Since confirmation samples will be analyzed at priority turn around, no exceedances of holding time are expected. Holding times will be calculated from the time the sample is collected to the subsequent extraction, if necessary, or analysis. Samples will be delivered to the laboratory by same day courier or overnight delivery, when warranted, in sealed coolers with ice.

### **4.2 Chain of Custody**

Samples will be accompanied by a Chain of Custody from the point of sampling to delivery of the samples to the laboratory. The Chain of Custody will be a record of the location where the sample was collected, the date and time collected, number of containers collected, type(s) of analyses requested, special remarks or requests, and the signature of each custodian of the samples. The completed chain of custody will be included in hard copies of reports.

Upon sample receipt, laboratory personnel will be responsible for sample custody. The laboratory sample custodian will verify sample integrity and compare the cooler contents against the field chain of custody. If a sample container is broken or leaking it will be noted on the Chain of Custody form and RG&E project personnel will be immediately notified. If labeling or descriptive errors are observed by the sample custodian, RG&E project personnel will be contacted immediately to resolve any discrepancies. After the discrepancies are resolved, the laboratory will acknowledge receipt of the samples (i.e., by signing and dating the Chain of Custody) and the completed chain of custody will be included in hard copies of reports and become a permanent part of the project records.

#### **4.2.1 Sample Identification**

Each sample collected during the project will have a unique identification number. This number, date of collection and type of analysis will be placed on each sample container after the sample is collected. A Site map will be used throughout the project to denote the area or point that a confirmatory sample represents. Each confirmatory sample will be assigned a sample point number, which will appear as characters 9 & 10.



### **4.3 Laboratory Sample Tracking**

Each laboratory has an internal tracking mechanism to ensure that each sample received has a unique identification number and that results generated and reported for each sample correspond to the identification number assigned at the laboratory.

## 5.0 EQUIPMENT CALIBRATION PROCEDURES

Each analysis will be performed in accordance with NYSDOH ELAP (Environmental Laboratory Approval Program) sanctioned methods or equivalent U.S. EPA analytical procedures. Each procedure specifies the method and frequency of calibration necessary to perform accurate and precise analyses. Each analytical instrument verifies the Minimum Detection Limit at least every six months as prescribed by the NYSDOH ELAP. The calibration of the instruments are verified at the beginning and end of each auto sampler run. Gas Chromatograph/Mass Spectrometers are tuned and calibrated every 12 hours, at a minimum.

Field equipment, for real time and speciated real time air analyses will be calibrated daily, in accordance with manufacturer's recommendations. Equipment will be calibrated more frequently if conditions warrant. The total organic analyzer equipped with a photo ionization detector (PID) will be used to measure volatile organic vapors and will be calibrated to benzene with a 10 ppm isobutylene air standard. The DataRam™ and a Thermo Andersen ADR-1200s used to measure particulates will be calibrated to zero with filtered air sample. The portable gas chromatograph unit will be used to measure the BTEX (benzene, toluene, ethylbenzene and xylenes) compounds and will be calibrated to a BTEX standard.

**6.0 ANALYTICAL PROCEDURES**

**6.1 Laboratory Analyses**

The following charts show the analytical method to be used for each analyte or group of analytes for the Project:

<b>TABLE E</b>	
<b>ANALYTICAL METHODS</b>	
<b>Analyte</b>	<b>Analytical Method</b>
TCLP Extractions	SW 846 Method 1311
TCLP Volatiles	SW 846 Method 8260
TCLP Semi volatiles	SW 846 Method 8270
TCLP Metals	SW 846 Method 6000/7000 Series
TCLP Pesticides/Herbicides	SW 846 Method 8080/8151
Polycyclic Aromatic Hydrocarbons (Table F)	SW 846 Method 8270
Total Volatiles	SW 846 Method 8260
Total Semi volatiles	SW 846 Method 8270
Total Metals	SW 486 Method 6000/7000 Series
PCBs	SW 846 Method 8082
Reactive Sulfide	SW 846 Chapter 7.3.4.2
Reactive Cyanide	SW 846 Section 7.3.3.2
Percent Sulfur	ASTM D-129
BTU/lb	ASTM D-215
Flashpoint	ASTM D-93
Ignitability	SW 846 Method 1030
Reactivity	SW 846 Section 7
Corrosivity	SW 846 Section 7
Percent Solids	ASP Method D-V-Section IX
pH	SW 846 Method 9045
Total Cyanide	SW 846 9012
Paint Filter Test	SW 846 9095

<b>TABLE F</b>	
<b>Polycyclic Aromatic Hydrocarbon (PAH) Analyte List</b>	
<b>PARAMETER</b>	
Naphthalene	
2-Methylnaphthalene	
Acenaphthene	
Acenaphthylene	
Fluorene	
Phenanthrene	
Anthracene	
Fluoranthene	
Dibenzofuran	
Pyrene	
Benzo (g,h,i) perylene	
Benzo (a) anthracene*	
Chrysene*	
Benzo (b) fluoranthene*	
Benzo (k) fluoranthene*	
Benzo (a) pyrene*	
Indeno (1,2,3 cd) pyrene*	
Dibenzo (a, h) anthracene*	
<b>*Carcinogenic PAHs (cPAH)</b>	

**6.2 Laboratory Selection**

The laboratory chosen for the project must be certified, and maintain certification, under the NYSDOH ELAP and NYSDOH ELAP CLP for analyses of solid and hazardous waste. Only analytical laboratories that have experience in MGP projects or similar projects will be considered for use.

## **7.0 DATA REDUCTION VALIDATION AND REPORTING**

### **7.1 Data Reduction**

#### **7.1.1 Field Data Collection**

Real time field data collected during sampling events will include qualitative information regarding the texture, appearance, odors, and any other observations made while soil and water samples are being collected. Meteorological data and current site activity will be noted while collecting data for real time air monitoring. These observations will be recorded in the field logbook.

#### **7.1.2 Laboratory Data Collection and Reduction**

A significant portion of the analyses performed requires the use of automated laboratory instrumentation. Raw data collected from the instruments detectors will be converted to standard units of mg/Kg for solid matrices and mg/L for water. Raw data will be stored in electronic form and in laboratory notebooks, in case the analysis needs to be recreated. Raw data for analyses will be archived for a minimum of four years.

### **7.2 Data Review**

Analytical data will be verified for precision and accuracy utilizing the laboratory's in-house Quality Assurance/Quality Control programs. In addition, data packages will be reviewed by RG&E project personnel to ensure that data deliverables have been properly provided.

### **7.3 Full Data Validation**

The full third party data validation process consists of a formal systematic review of analytical results and quality control documentation with regards to the parameters cited in section 8.3. On the basis of this review, a third party data validator will make judgments and express concerns on the quality and limitations of the specific data and the validity of the data package as a whole. The data validator prepares documentation of his or her review using the standard USEPA Inorganics Regional assessment and Organics Regional assessment forms to summarize deficiencies and general laboratory performance. These forms are accompanied by appropriate supplementary documentation, which identifies specific problems.

Since a full data validation would typically be used for the purposes of litigation, this level of review may surpass the scope of work necessary for the project. Therefore, full data validation for analytical results of confirmatory samples will be performed at RG&E's discretion. Confirmatory sampling data will be archived in the event that it becomes necessary to perform a full data validation at a future date.

#### 7.4 Data Usability Summary Report

A Data Usability Summary Report provides a thorough review and evaluation of analytical data without the formality of a full third party data validation. A Data Usability Summary Report for the analytical results of confirmatory samples will be generated in lieu of a full data validation to verify that the proper data deliverables and procedures have been rendered in accordance with the data quality objectives of the *Work Plan*.

#### 7.5 Reporting

Final reports for analytical data will be reviewed and accepted by RG&E prior to submission to the NYSDEC. Reports for analyses performed under the ELAP protocol will contain result sheet for the sample analyzed. These reports must include at a minimum:

- RG&E Sample ID number;
- Laboratory sample ID number;
- Sample collection date;
- Extraction or digestion date (if applicable);
- Date Analyzed;
- Analytical method;
- Analytical results (with units clearly identified);
- Results of laboratory blank and field blanks;
- Results of spikes, matrix spikes and duplicates;
- Surrogate recoveries (if applicable);
- Completed Chain of Custody forms; and
- Field log sheets (if available)

## **8.0 QUALITY CONTROL CHECKS**

### **8.1 Field Quality Control**

#### **8.1.1 Decontamination Procedures for Confirmation Sampling**

The following decontamination procedure will be followed for non-disposable sampling equipment before being reused.

- Equipment will be washed thoroughly with a non-phosphate detergent.
- The equipment will then be rinsed with analyte-free water.
- The equipment will be rinsed with a reagent grade methanol solution diluted with analyte-free water.
- If the equipment is being used for the collection of samples for metals analyses it will then be rinsed with a 10% reagent grade nitric acid solution.
- The equipment will be rinsed with analyte-free water.

After decontamination, equipment will be carefully stored to avoid contamination between sampling events.

### **8.2 Laboratory Quality Control**

Each laboratory will be NYSDOH Certified for the analyses they will perform. Each analyst must complete a start-up proficiency procedure to demonstrate their capability to perform accurate and precise analyses on each type of instrument they operate. In addition, each laboratory must accurately analyze samples provided by NYSDOH on a semi annual basis to maintain certification. The laboratories have internal quality control officers that review methodologies and implement corrective action, including reanalyzing samples which do not pass established laboratory quality control criteria.

Laboratory quality control procedures are specified in the analytical methods. These specifications include the type of laboratory quality control check required, compounds and concentrations to be used, and laboratory quality control acceptance criteria.

Laboratory quality control checks will include (where specified by method):

- Calibration Standards
- Methods Blanks
- Matrix Spike/Matrix Spike Duplicates
- Surrogate Spikes
- Internal Standards
- Laboratory Duplicates
- Calibration Check Standards
- Laboratory Control Samples

## **9.0 PREVENTATIVE MAINTENANCE**

### **9.1 Field Instruments and Equipment**

Equipment, instruments, tools, gauges, and other items requiring preventive maintenance will be serviced in accordance with the manufacturer's specified recommendations or written procedures developed by the operators. Field equipment service will be conducted by qualified personnel. Prior to field sampling, each piece of field equipment will be inspected to ensure that it is operational. If the equipment is not operational, it must be repaired prior to use. Equipment which require charging of batteries will be fully charged or have fresh batteries at the start of the project. An equipment repair/maintenance log will be kept for each field instrument. Non-operational/non-repairable field equipment will be replaced.

### **9.2 Laboratory Instruments and Equipment**

Each laboratory has an instrument/equipment maintenance program, which includes procedures for daily, weekly, monthly, or annual routine maintenance. In addition, maintenance is performed if the accuracy and/or precision of the instrument are in question.

#### **9.2.1 Instrument Maintenance**

Preventive maintenance of laboratory instruments will be conducted in accordance with the manufacturer's guidelines or written procedures developed by the operators. Instrument service will be performed by qualified personnel. To minimize potential downtime, the laboratory will maintain a sufficient supply of critical spare parts for its instruments and, where practical, maintain a service contract for rapid instrument repair. Wherever possible, the laboratory will retain backup instrumentation. An instrument repair/maintenance log will be maintained for each instrument.

#### **9.2.2 Equipment Monitoring**

On a daily basis, the operation of the laboratory equipment (i.e., balances, ovens, refrigerators, water purification systems, etc.) will be checked and documented. Discrepancies will be immediately reported to the appropriate laboratory personnel for resolution.



***RG&E***

**ROCHESTER GAS & ELECTRIC CORPORATION**  
89 East Avenue  
Rochester, New York 14649

## **Appendix E**

# **TRANSPORTATION OF SOLID AND/OR LIQUID MATERIALS**

**ASSOCIATED WITH THE**

**EAST STATION  
FORMER MANUFACTURED GAS PLANT SITE**

## **Tar Well Removal IRM**

**City of Rochester, Monroe County, New York**  
**VCA Index #: B8-0535-98-07**  
**Site #: V000358-8**

October 8, 2004

Prepared By:  
RG&E Environmental Affairs

**TABLE OF CONTENTS**

<b>Section</b>	<b>Page</b>
1.0 SCOPE OF WORK .....	1
2.0 WORK BY CONTRACTOR.....	1
3.0 GENERAL WORK CONDITIONS .....	1
4.0 WASTE TRANSPORTATION ROUTES .....	4

## **1.0 SCOPE OF WORK**

This plan is for the transportation of solid and/or liquid non-hazardous and hazardous waste for the East Station former manufactured gas plant site, City of Rochester, Monroe County, New York Tar Well Contents Removal IRM Work Plan.

## **2.0 WORK BY CONTRACTOR**

**2.1** The transporter shall provide supervision, training, permits, labor, tools, equipment, consumable materials, and expendable materials, to transport solid and/or liquid waste as detailed herein.

## **3.0 GENERAL WORK CONDITIONS**

**3.1** The transporter shall comply with all applicable provisions of New York State Department of Environmental Conservation Regulation, 6 NYCRR Part 364 "Waste Transporters Permit", Title 6 of the Official Compilation of Codes, Rules and Regulations.

**3.2** The transporter shall comply with all applicable provisions of New York State Department of Environmental Conservation Regulation 6 NYCRR Part 372 "Hazardous Waste Manifest System and Related standards for Generators, Transporters and Facilities", Title 6 of the Official Compilation of Codes, Rules and Regulations.

**3.3** The transporter shall comply with all applicable provisions of New York State Department of Transportation (NYSDOT), the New York State Department of Motor Vehicle, and/or any other applicable Federal, State, and Local Laws.

**3.4** The transporter shall comply with applicable provisions of OSHA 29 CFR 1910.120 "40 hours Hazardous Waste Operations Health & Emergency Response".

**3.5** The transporter shall develop and implement a written Health & Safety Plan for their drivers that meets or exceeds the site Health & Safety Plan and which addresses potential exposure to MGP residuals.

**3.6** The transporter shall adhere to the RG&E Contractor rules while working on an RG&E MGP Site and/or on an RG&E Property.

- 3.6.1** Any truck found unacceptable by RG&E or the RG&E Field Representative and/or the MGP Site's designated Health & Safety Officer may be rejected. The cost for rejected trucks shall be born by the transporter.
- 3.6.2** The truck drivers will report their arrival to the RG&E Field Representative and/or the MGP Site's designated Health & Safety Officer.
- 3.6.3** Truck drivers are generally restricted to their trucks and the designated waiting areas. Drivers are not permitted access to the MGP Sites without express permission from a representative of RG&E.
- 3.6.4** Truck drivers will don **hard hats, safety glasses, safety shoes/boots, and gloves**, as a minimum for personal protection, when on RG&E's MGP Sites and/or RG&E's Power Station Sites.
- 3.6.5** Per RG&E's discretion, trucks transporting coal tar non-hazardous solid waste or coal tar contaminated hazardous solid waste may have the driver line the entire box (to top of side boards) with three mils thick polyethylene sheets (poly sheets). Trucks will also have a gasket between the box and tailgate.
- 3.6.6** Trucks are required to have working audible and or visual backup signals.
- 3.6.7** When loading or when directed by a representative of the RG&E, the truck engine should be shut off. Each truck may be restarted and driven away only after receiving the "**all clear**" direction from the loader operator, or RG&E's Field Representative.
- 3.6.8** Truck engines are not allowed to idle in residential or other areas where the exhaust and/or noise could be a nuisance.
- 3.6.9** No trucks will be loaded above the side boards and no material will be spilling out of the truck. The trucks' exteriors will be cleaned (by remediation contractors) of material being loaded before they leave the loading area.
- 3.6.10** RG&E remedial workers will reposition tarp bars over waste materials. Drivers will not be allowed to walk over waste material.
- 3.6.11** The drivers will cover trucks with tarps inside the loading area after the sides of the trucks have been cleaned.
- 3.6.12** Obey traffic signs and notices (obey the posted speed limit).

- 3.6.13** Obey rules posted on the site and/or any site specific Health & Safety Plan rules for all employees.
- 3.6.14** Report any accidents to the RG&E's Field Representative and/or the MGP Site's designated Health & Safety Officer and cooperate with any subsequent accident investigation.
- 3.6.15** No children under 16 years of age are allowed on MGP Sites.
- 3.6.16** Slow down and be extra cautious during times of poor weather (rain, fog, and snow).
- 3.6.17** Take extra care around blind corners (watch for construction equipment and pedestrians).
- 3.6.18** Smoking, eating, and/or drinking is **not permitted** within the security fence (Contamination Reduction Zone and Exclusion Zone). Smoking, eating, and/or drinking is permitted only in designated areas.
- 3.6.19** After disposal of material, the transporter is responsible for properly decontaminating their truck and/or equipment.

#### 4.0 WASTE TRANSPORTATION ROUTES

Prior to the commencement of the IRM activities truck traffic routes will be prepared identifying the transportation routes that the trucks will be required to follow during the transportation of the various wastes from the site to the disposal facility(s).

***RG&E***

**ROCHESTER GAS & ELECTRIC CORPORATION**  
89 East Avenue  
Rochester, New York 14649

## **Appendix F**

# **CONTINGENCY PLAN**

**ASSOCIATED WITH THE**

**EAST STATION  
FORMER MANUFACTURED GAS PLANT SITE**

## **Tar Well Removal Work Plan**

**City of Rochester, Monroe County, New York**  
VCA Index#: B8-0535-98-07  
Site #: V000358-8

October 8, 2004

Prepared By:  
RG&E Environmental Affairs

# RGE

East Station Former Manufactured Gas Plant Site , City of Rochester, New York  
Contingency Plan associated with the Tar Well Removal IRM Work Plan

---

## TABLE OF CONTENTS

<b>Section</b>	<b>Page</b>
1.0 CONTINGENCY PLAN .....	1
1.1 Identifying the Hazards and Assessing the Risk .....	1
1.2 Conditions for Implementing a Contingency Plan .....	2
1.2.1 Fire and/or Explosion Conditions .....	2
1.2.2 Spill or Material Release Conditions .....	2
1.2.3 Severe Weather Conditions .....	3
1.2.4 Physical or Chemical Injury Conditions .....	3
1.3 Contingency Procedures .....	3
1.3.1 Contingency Procedures for Fire/Explosion .....	3
1.3.2 Contingency Procedures for Spills or Material Releases .....	4
1.3.3 Contingency Procedures for Severe Weather .....	5
1.3.4 Contingency Procedures for Physical Injury to Workers .....	5
1.3.5 Contingency Procedures for Chemical Injury to Workers .....	6
2.0 EMERGENCY EVACUATION PROCEDURES .....	7
2.1 Site Evacuation Procedures .....	7
2.2 Off-Site Evacuation Procedures .....	8



# RGE

East Station Former Manufactured Gas Plant Site, City of Rochester, New York

Contingency Plan associated with the Tar Well Removal IRM Work Plan

---

## 1.0 CONTINGENCY PLAN

This *Contingency Plan* is designed to address potential emergencies that may arise as a result of operations during the interim remedial measure remediation project to be completed at the East Station former manufactured gas plant site, City of Rochester, Monroe County, New York. This Plan supplements the *Interim Remedial Measures Work Plan for the Tar Well Contents Removal Associated with the East Station Former Manufactured Gas Plant Site*.

The Site Safety Officer will be made aware of the emergencies and coordinate response activities carried out at the site. The Site Safety Officer will serve as the overall Project Emergency Coordinator and have the ultimate authority in specifying and facilitating any contingency action.

If the Site Safety Officer is not able to perform these duties, he will specify another senior individual to serve in this capacity. The Project Emergency Coordinator will become familiar with contingency plans developed by each contractor and subcontractor.

### 1.1 Identifying the Hazards and Assessing the Risk

The objectives during any emergency shall be to protect human health and safety and then the environment. Possible hazards to human health or environment that may result from an emergency situation will be identified by the Project Emergency Coordinator. The Project Emergency Coordinator must take into consideration both direct and indirect effects of the incident.

The Project Emergency Coordinator will then assess the possible risks to human health or the environment that may result from the emergency (e.g., release, fire, explosion, or severe weather conditions). He will make this assessment by:

- identifying the materials involved in the incident;
- consulting the appropriate Occupational Health Guideline or Material Safety Data Sheet (MSDS) to determine the potential effects of exposure/release, and appropriate safety precautions; and
- identifying the exposure and/or release pathways and the quantities of materials involved.

Based on this information the Project Emergency Coordinator will determine the best course of action for dealing with the emergency, and possible follow-up requirements that may result from implementing those actions (e.g., equipment repair, material disposal, etc.).

If the incident cannot be controlled by operating personnel without incurring undue risk, the Project Emergency Coordinator will implement the Site Evacuation Procedures (Section 2.1)

# **RGE**

East Station Former Manufactured Gas Plant Site , City of Rochester, New York  
Contingency Plan associated with the Tar Well Removal IRM Work Plan

---

If off-site neighboring population is at risk the Off-Site Evacuation Procedures (Section 2.2) will be implemented. The Project Emergency Coordinator will notify the RG&E project manager and the appropriate government agencies and departments that a situation resulting in evacuation has occurred. Should emergency assistance in treating injuries or carrying out the evacuation be required, the Project Emergency Coordinator will request assistance of the appropriate parties.

## **1.2 Conditions for Implementing a Contingency Plan**

Some of the conditions under which the contingency plan would be implemented are:

- fire or explosion;
- occurrence of a spill or material release;
- severe weather conditions; and
- physical or chemical injury to a worker.

### **1.2.1 Fire and/or Explosion Conditions**

Contingency procedures will immediately be implemented upon notification that any of the following scenarios involving fire and/or explosion is imminent or has occurred:

- a fire that causes, or could cause, the release of toxic fumes;
- a fire that could possible ignite nearby flammable containers or could cause heat-induced explosions;
- a fire that could possibly spread to off-site areas;
- a danger exists that an explosion could occur causing a safety or health hazard; and
- an explosion has occurred.

### **1.2.2 Spill or Material Release Conditions**

The following scenarios involving a spill or material release, whether imminent or having already occurred, will cause implementation of contingency procedures:

- a spill or material release that could result in the release of flammable liquids or vapors, thus causing a fire or gas explosion hazard;
- a spill or material release that could cause the release of toxic vapors or fumes into the atmosphere in concentrations higher than the OSHA Permissible Exposure Limits (PELs);
- a spill or material release that can be contained on-site where a potential exists for groundwater or surface water contamination; and

# **RGE**

East Station Former Manufactured Gas Plant Site , City of Rochester, New York  
Contingency Plan associated with the Tar Well Removal IRM Work Plan

---

- a spill or material release that cannot be contained on-site, resulting in a potential for off-site soil contamination and/or groundwater or surface water pollution.

The Project Emergency Coordinator (or sub-contractor's emergency coordinator) will immediately identify the character, source, amount, and extent of any release. Spills or material releases shall be reported immediately to the Project Emergency Coordinator. Initial identification will be based on visual analysis of the material and location of the release. If the release material cannot be identified, samples will be taken for analysis.

## **1.2.3 Severe Weather Conditions**

The following severe weather conditions, whether imminent or having occurred, may cause implementation of contingency procedures.

- a tornado (or other violent wind storm) has been sighted in the area;
- a tornado warning is in effect for the area;
- a lightning storm is underway in the area (storm center less than 5 miles away); and
- other severe weather or weather induced conditions (e.g., hurricane or flood).

## **1.2.4 Physical or Chemical Injury Conditions**

The following worker injuries may cause implementation of this *Contingency Plan*:

- major physical injuries;
- chemical injuries; and/or
- severe symptoms of chemical overexposure.

## **1.3 Contingency Procedures**

If any of the aforementioned conditions for implementing the Contingency Plan are met, the appropriate following contingency procedure(s) shall be performed.

### **1.3.1 Contingency Procedures for Fire/Explosion**

When fire or explosion appear imminent or have occurred, normal activity in affected areas will cease. The Project Emergency Coordinator will make an assessment of the potential risk and severity of the situation to decide whether the emergency event will or will not be readily controllable with existing portable fire extinguishers or site equipment and materials at hand. Fire fighting will not be done at the risk to site workers. Local fire departments will be

# **RGE**

East Station Former Manufactured Gas Plant Site , City of Rochester, New York  
Contingency Plan associated with the Tar Well Removal IRM Work Plan

---

contacted in all situations in which fires and/or explosions have occurred. The following steps will be taken for localized fire.

- contact local fire departments by calling 911;
- move personnel to an upwind location at an appropriately safe distance away;
- assess if fire is within on-site personnel capabilities to attempt initial fire fighting;
- if the fire is within on-site personnel capabilities, utilize most appropriate means of extinguishing fire (e.g., fire extinguishers, water, covering with soil, etc.); and
- once fire is extinguished, containerize and properly dispose of any spilled material, runoff, or soil.

If the situation appears uncontrollable and poses a direct threat to human health, fire departments will be contacted and the Evacuation Plan will be implemented. If the chances of an impending explosion are high, the entire area within a 1,000-foot radius of the fire source will be evacuated. The Project Emergency Coordinator will alert personnel when all danger has passed, as determined by the chief fire fighter from the responding fire department. Equipment used in the emergency will be cleaned and refurbished as soon as possible after the emergency has passed so that it will be ready for use in the event of any future emergency.

## **1.3.2 Contingency Procedures for Spills or Material Releases**

If a hazardous waste spill or material release or process upset resulting in probable vapor release is identified, the Project Emergency Coordinator will immediately assess the magnitude and potential seriousness of the spill or release based upon;

- MSDS for the material spilled or released;
- source of the release or spillage of hazardous material;
- an estimate of the quantity released and the rate at which it is being released;
- the direction in which the spill or air release is moving;
- personnel who may be or may have been in contact with material, or air release, and possible injury or sickness as a result;
- potential for fire and/or explosion resulting from the situation; and
- estimates of area under influence of release.

If the spill or release is determined to be within the on-site emergency response capabilities, the Project Emergency Coordinator will ensure implementation of the necessary remedial action. If the accident is beyond the capabilities of the operating crew, personnel not involved with emergency response activity will be evacuated from the immediate area and the appropriate emergency response group(s) will be contacted.

# **RGE**

East Station Former Manufactured Gas Plant Site , City of Rochester, New York  
Contingency Plan associated with the Tar Well Removal IRM Work Plan

---

## **1.3.3 Contingency Procedures for Severe Weather**

If a tornado is sighted in the area, or if a tornado warning has been issued, or if a lightning storm occurs, the information will be immediately relayed to the Project Emergency Coordinator. In the case of a tornado sighting, the Project Emergency Coordinator will then institute emergency shutdown procedures, and personnel will be directed to proceed to a safe location after completing appropriate shutdown procedures. In the case of a tornado warning, or lightning storm, the Project Emergency Coordinator will have operations stopped and direct personnel to stand by for emergency procedures. Other types of weather or weather inducted conditions (e.g., hurricane or flooding) for which long range prediction is available may also require positive action as identified herein.

When the severe weather has passed, the Project Emergency Coordinator will direct the contractor's to inspect on-site equipment to ensure its readiness for operation prior to restarting operations.

If an inspection indicates a fire, explosion, or release has occurred as the result of a severe weather condition, the procedures for those events will be followed.

## **1.3.4 Contingency Procedures for Physical Injury to Workers**

Regardless of the nature and degree of the injury, the Project Emergency Coordinator will be apprised of all injuries requiring first aid of any kind. A report of the injury or incident will be completed as required by *Health and Safety Plan*.

Upon notification that a worker has been injured, the Project Emergency Coordinator will immediately determine the severity of the accident, and whether the victim can be safely moved from the incident site. Appropriate medical assistance will be summoned immediately.

Minor injuries sustained by workers will be treated on-site using materials from the first aid kits. Whenever possible, such treatment will be administered by trained personnel in a "clean zone". Examples of minor injuries include small scrapes and blisters. Minor injuries would not be expected to trigger implementation of the contingency plan.

Major injuries sustained by workers will require professional medical attention at a hospital. The Project Emergency Coordinator will immediately summon an ambulance and contact the hospital to which the injured worker will be transported. The Project Emergency Coordinator will notify the RG&E project manager as soon as practical. The hospital and ambulance should be advised of:

- the nature of the injury;

# **RGE**

East Station Former Manufactured Gas Plant Site , City of Rochester, New York

Contingency Plan associated with the Tar Well Removal IRM Work Plan

---

- whether the injured worker will be decontaminated prior to transport;
- when and where the injury was sustained; and
- the present condition of the injured work (e.g., conscious, breathing).

## **1.3.5 Contingency Procedures for Chemical Injury to Workers**

Injuries involving hazardous chemicals or symptoms of severe chemical overexposure will automatically trigger implementation of the contingency plan. Upon notification that a chemical injury has been sustained or severe symptoms of chemical exposure are being experienced, the Project Emergency Coordinator will notify the hospital and ambulance of the occurrence. The Project Emergency Coordinator will provide, to the extent possible, the following information:

- the nature of the injury (e.g., eyes contaminated);
- the chemical(s) involved;
- the present condition of the injured worker (e.g., conscious, breathing);
- whether the injured worker will be decontaminate prior to transport; and
- when and where the injury was sustained.

Steps will immediately be taken to remove the victim from the incident site using whatever personal protective equipment (PPE) and safety equipment is necessary. Rescuers will check for vital signs and, if possible, remove contaminated outer clothing. If the victim's eyes have been contaminated, personnel trained in administering first aid will flush the victim's eyes with eyewash solution until the emergency response team arrives.

Details on the nature of the contaminant and methods for treating exposure or injury can be obtained from the MSDSs or Occupational Health Guidelines as provided in the *Health and Safety Plan*.

# **RGE**

East Station Former Manufactured Gas Plant Site , City of Rochester, New York  
Contingency Plan associated with the Tar Well Removal IRM Work Plan

---

## **2.0 EMERGENCY EVACUATION PROCEDURES**

### **2.1 Site Evacuation Procedures**

If an emergency occurs that requires the evacuation of an area to ensure personnel safety, including (but not limited to) fire, explosion, severe weather or hazardous waste/material spills, or a significant release of vapors into the atmosphere, an air horn will be sounded on the site by the nearest person aware of the event. The horn will sound continuously for approximately 10 seconds, signaling that immediate evacuation of all personnel from the area is necessary as a result of some existing or impending danger. In areas where only two or three people are working side by side, and the need to evacuate can be communicated verbally, the air horn will not be necessary by the nearest person aware of the event.

Heavy equipment in the area will be shutdown. Under no circumstances will incoming visitors (other than emergency response personnel) be allowed to enter any area where an emergency is occurring. Visitors or observers and non-essential personnel present in the area of an emergency will be instructed to evacuate the area immediately.

Contractor and subcontractor emergency coordinators and/or health and safety officers (as designated) will be responsible for ensuring that emergency response requirements specific to their own operations are carried out. These parties will report their activities to the Project Emergency Coordinator. The Project Emergency Coordinator, however, has final authority regarding all emergency response activities.

Non-essential personnel shall evacuate the emergency areas and notify personnel in adjacent areas to evacuate also. The evacuated workers will assemble at the primary assembly area at the site construction office trailer, where the Project Emergency Coordinator will give directions for implementing necessary actions. In the event that the primary assembly area is involved, unapproachable, or unsafe due to the event, evacuated workers shall assemble at the alternate assembly area at the main site entry gate located by the laboratory and coal lab buildings. The Project Emergency Coordinator will phone for backup assistance. Personnel are to avoid encountering smoke/gas plumes as practicable during evacuation and assembling.

The Project Emergency Coordinator will take charge of emergency response activities and dictate the procedures that will be followed until emergency personnel arrive. The Project Emergency Coordinator will assess the seriousness of the situation, and direct whatever efforts are necessary until the emergency response units arrive.

After initiating emergency response procedures, the Project Emergency Coordinator will assign appropriate personnel to check and attempt to ensure that access roads are not obstructed. If traffic control is necessary, as in the event of a fire or explosion, personnel

# **RGE**

East Station Former Manufactured Gas Plant Site , City of Rochester, New York  
Contingency Plan associated with the Tar Well Removal IRM Work Plan

---

who have been trained in these procedures and designated at the project safety meeting will take over these duties until emergency units arrive.

The Project Emergency Coordinator will remain at the site to provide any assistance requested by emergency-response squads as they arrive to deal with the situation. The Project Emergency Coordinator will have the authority to shut down any part or all of the project after an emergency until he deems it safe to continue operations. He will dictate any changes in project safety practices which are made necessary by the emergency that has occurred or are required for preventing further emergencies.

## **2.2 Off-Site Evacuation Procedures**

If the Project Emergency Coordinator deems that humans outside of the site are at risk, he will notify the appropriate agencies and departments (e.g., RG&E project manager, Monroe County Department of Health, Monroe County Sheriff Department, New York State Department of Environmental Conservation and New York State Department of Health, etc.) of the need or potential need to institute off-site evacuation procedures. The Project Emergency Coordinator will provide, at a minimum, the following information:

- his or her name and telephone number;
- name and address of facility;
- time and type of incident (e.g., release, fire, etc.)
- name and quantity of materials or materials involved, to the extent this information is known;
- the extent of injuries, if any; and
- the possible hazards to human health or environment, and cleanup procedures.



***RG&E***

**ROCHESTER GAS & ELECTRIC CORPORATION**  
89 East Avenue  
Rochester, New York 14649

## **Appendix G**

# **ORGANIZATION STRUCTURE**

**ASSOCIATED WITH THE**

**EAST STATION  
FORMER MANUFACTURED GAS PLANT SITE**

## **Tar Well Removal Work Plan**

**City of Rochester, Monroe County, New York**  
VCA Index#: B8-0535-98-07  
Site #: V000358-8

October 8, 2004

Prepared By:  
RG&E Environmental Affairs

# CONCEPTUAL ORGANIZATION STRUCTURE FOR REMOVAL OF THE TAR WELL CONTENTS IRM WORK PLAN EAST STATION FORMER MANUFACTURED GAS PLANT SITE

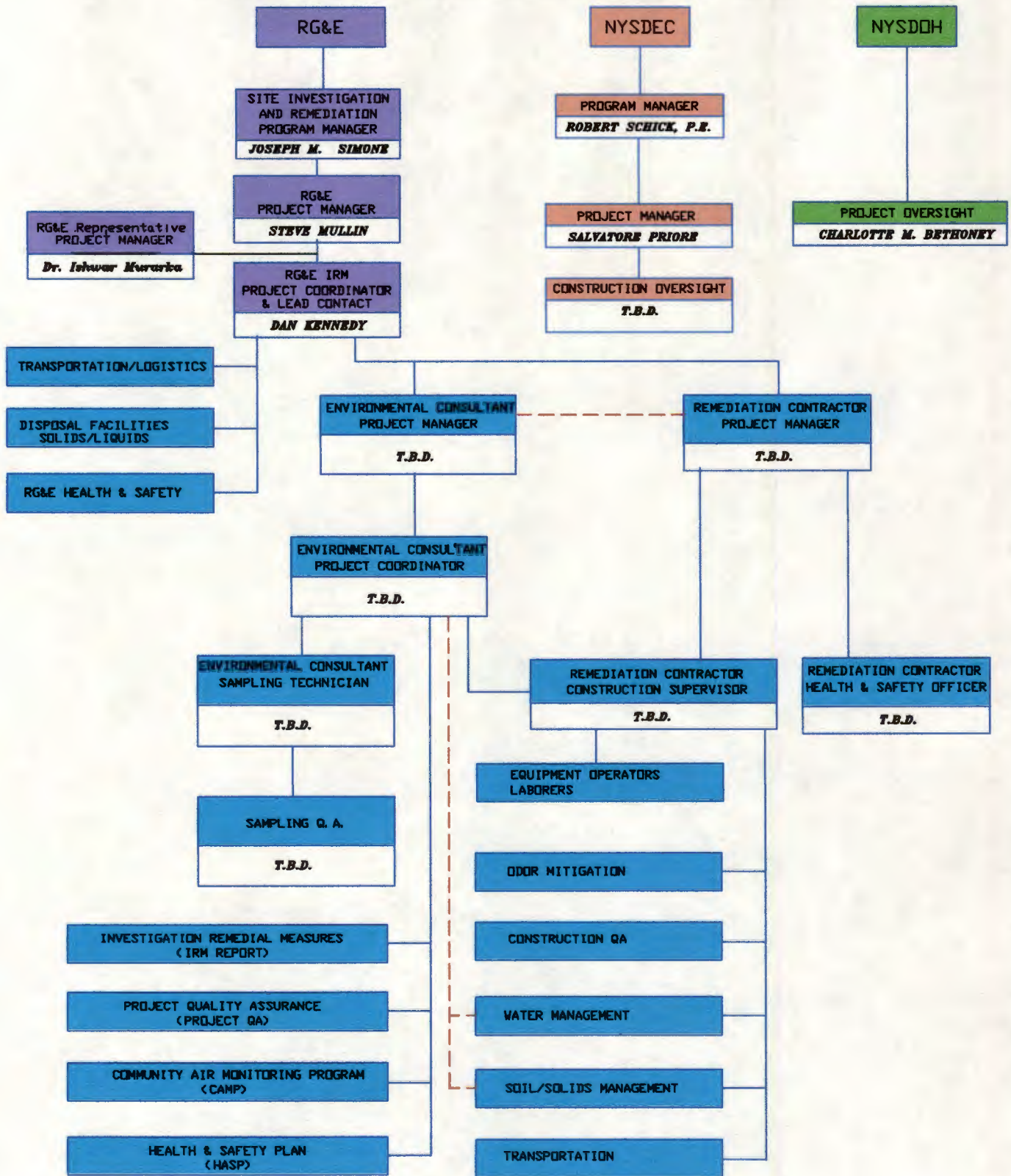

***RG&E***

**ROCHESTER GAS & ELECTRIC CORPORATION**  
89 East Avenue  
Rochester, New York 14649

## **Appendix H**

# **Project Schedule**

**ASSOCIATED WITH THE**

**EAST STATION  
FORMER MANUFACTURED GAS PLANT SITE**

## **Tar Well Removal Work Plan**

**City of Rochester, Monroe County, New York**  
VCA Index#: B8-0535-98-07  
Site #: V000358-8

October 8, 2004

Prepared By:  
RG&E Environmental Affairs

**Proposed Schedule for the Former Gas Holder / Tar Well Removal IRM  
at the East Station Former MGP Site**

<b>Key Milestone</b>	<b>Target Date(s)</b>
Submit Final Work Plan for the Gas Holder / Tar Well IRM to the NYSDEC	October 8, 2004
<b>Implement Pre-IRM Characterization SAP</b>	<b>10/18/2004 through 10/22/2004</b>
Acquire Contractors & Consultants	10/04/2004 through 11/10/2004
Complete Evaluation of Pre-characterization Data	11/15/2004
Start Project Set up, Mobilization and Site Preparation	11/15/2004 through 11/30/2004
<b>Begin Excavation Activities*</b>	<b>12/01/2004</b>
Complete Excavation, Backfilling, Site Regrading, etc...*	2/15/2005
Finalize & Submit Draft IRM Completion Report to the NYSDEC	4/15/2005

\*Please note that the Excavation activities may have to be temporarily interrupted due to cold weather in the Rochester area. Such an interruption will require change in the completion schedule for the IRM.

***RG&E***

**ROCHESTER GAS & ELECTRIC CORPORATION  
89 East Avenue  
Rochester, New York 14649**

**Appendix I**

**VAPOR EMISSION RESPONSE PLAN**

**ASSOCIATED WITH THE**

**EAST STATION  
FORMER MANUFACTURED GAS PLANT SITE**

**Tar Well Removal Work Plan**

**City of Rochester, Monroe County, New York  
VCA Index#: B8-0535-98-07  
Site #: V000358-8**

October 8, 2004

Prepared By:  
RG&E Environmental Affairs

# VAPOR EMISSION RESPONSE PLAN DIAGRAM

## Former East Station Manufactured Gas Plant Site

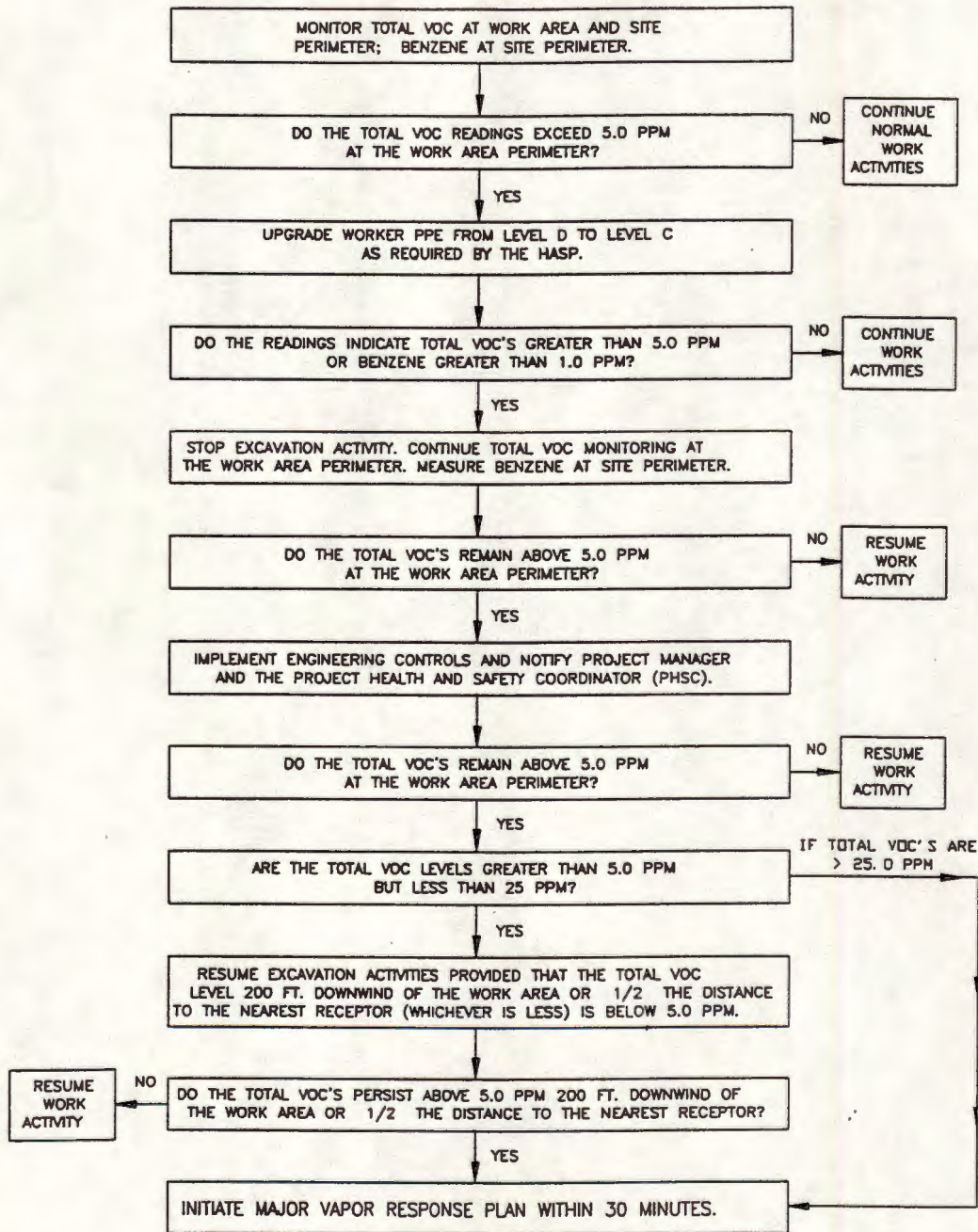

1. COVER THE EXCAVATED AREA WITH POLYETHYLENE SHEETING.
2. NOTIFY SALVATORE PRIORE WITH THE NYSDEC AT (518) 402-9665  
CHARLOTTE BETHONEY WITH THE NYSDOH AT (518) 402-7860,  
JOSEPH ALBERT WITH THE MCDOH AT (585) 274-6904, AND  
ROCHESTER POLICE DEPARTMENT AT 911.
3. TOTAL VOC LEVELS WILL BE MONITORED WITHIN 20 FEET OF THE NEAREST DOWNWIND RESIDENTIAL OR COMMERCIAL STRUCTURE. (20 FOOT ZONE).
4. CONTINUE AIR MONITORING 15-MINUTE INTERVALS IN THE 20 FOOT ZONE. IF TWO SUCCESSIVE READINGS BELOW ACTION LEVELS ARE MEASURED, AIR MONITORING INTERVALS MAY BE HALTED OR MODIFIED BY THE PHSC, WITH APPROVAL OF THE NYSDEC AND NYSDOH.
5. IF THE TOTAL VOC LEVELS PERSIST ABOVE THE 5.0 PPM WITHIN THE 20 FOOT ZONE, THE CONSTRUCTION SUPERVISOR, PHSC AND NYSEG MANAGER WILL CONSULT WITH EACH OTHER AND THE EMERGENCY RESPONSE AGENCIES TO DETERMINE APPROPRIATE ACTIONS TO BE IMPLEMENTED. NYSEG HAS ULTIMATE AUTHORITY DURING MAJOR VAPOR EMISSION EMERGENCIES.

***RG&E***

**ROCHESTER GAS & ELECTRIC CORPORATION**  
89 East Avenue  
Rochester, New York 14649

## **Appendix J**

# **BIOSOLVE® PRODUCT INFORMATION**

**ASSOCIATED WITH THE**

**EAST STATION  
FORMER MANUFACTURED GAS PLANT SITE**

## **Tar Well Removal Work Plan**

**City of Rochester, Monroe County, New York**  
VCA Index#: B8-0535-98-07  
Site #: V000358-8

October 8, 2004

Prepared By:  
RG&E Environmental Affairs

# BioSolve® InfoSheet



## Dilution & Application Rates

BioSolve is a concentrate and **MUST BE DILUTED** prior to use

BioSolve InfoSheet is a product of The Westford Chemical Corporation and may not be reproduced without expressed written consent. ALL RIGHTS RESERVED

Always use BioSolve in accordance with State, Federal or Local Approvals.

The following dilution rates have been found to be effective in most BioSolve applications. However, since site specific conditions vary, adjusting dilution rates slightly may be necessary for optimum efficiency.

BioSolve is water based and does not react like a solvent. BioSolve emulsifies, encapsulates, and disperses. Once it is understood that these are the only three actions of BioSolve, adjustments can be made in the dilution and / or the application method to attain the desired result. Protocols are available for many BioSolve applications.

Vapor Suppression  
Soil 3% - 6%

These applications rates vary and may need to be adjusted to site specific conditions. BioSolve can eliminate working hazards and, in many cases, the waste discharge can be treated in the plant's activated sludge ponds.

Tank Washout  
Fuels, Light Oils 3%  
Heavy Oils 6%

Application	Rates
Vapor Suppression	Call regarding site specific conditions
Bioremediations	Call regarding site specific conditions
Tank Washouts	Use through standard pressure washer
Fire Emergency Response	1 gallon of BioSolve concentrate to 6 gallons of hydrocarbon
Soil/Sludge Washing	Site specific
Spills Small	Mix 3 part water to 1 part BioSolve. Apply to spill, agitate with full pressure water stream
Large	Educt Through Foam Eductor at 6%

Soil, Rock, Sludge Washing 1% - 3%

Emergency Response  
Spills 6%

Fire 6%

Bioremediation  
Fuels, Light Oils 3%  
Heavy Oils, Crudes 6%

Food Grease Traps 5%

The Westford Chemical Corp. 1-800-225-3909 or (508) 392-0689  
FAX (508) 692-3487

Protocols Available for Most Applications

Distributed By:



# BioSolve® InfoSheet



## Vapor Suppression Spill Response

BioSolve InfoSheet is a product of The Westford Chemical Corporation and may not be reproduced without expressed written consent. ALL RIGHTS RESERVED

Always use BioSolve in accordance with State, Federal or Local Approvals.

BioSolve has an amazing ability to suppress or eliminate Volatile Organic Compounds (VOC's). Unlike a foam that suppresses vapor only as long as the blanket lasts, BioSolve's unique properties encapsulate and emulsify the hydrocarbon giving long term vapor suppression.

BioSolve, diluted to a 3% to 6% solution can be applied with any water applicator. Special equipment is not required. Since BioSolve is not a foam, it can be applied on high wind days as well as hillsides. For large sites, applicators can include foam eductors, water trucks, and sprinkler systems, for smaller jobs, a hand pump sprayer, water extinguisher, or garden hose with a fertilizer attachment on the nozzle works quite well.

Because BioSolve applies like water, it's applications are almost endless. In Underground Storage Tanks (UST's), BioSolve is used in the "Triple Rinse" washing procedure. BioSolve eliminates the recurrence of vapor release often associated with UST removals. Because BioSolve is a unique biosurfactant, it not only suppresses the vapor but cleans the tank right down to the metal. BioSolve can be used with any pressure washer with tremendous efficiency.

Water-Based  
Biodegradable

Fast--Suppresses VOC's  
within seconds!

Cost Effective--Lasts a  
long time

Simple-- Applies like  
water

Versatile--Replaces a  
variety of other  
chemicals.

Drum washers/recyclers find that BioSolve is ideal to handle a wide range of contaminated drums. A 6% solution of BioSolve is high pressure sprayed into the drums to wash them out. BioSolve's double action of encapsulation and cleaning, effectively cleans the drums in a one step application. BioSolve is so effective it is even used to clean out mercaptan drums with little to no odor release. Because *BioSolve enhances the bioremediation of organic compounds, it makes it possible to dispose of wash water to a plant's activated sludge pond.*

In refinery and on oil production platforms, BioSolve is proving an effective agent for suppressing VOC vapor in open drain systems during Turnarounds and Workover Operations

BioSolve is commonly utilized by Haz Mat, Emergency Response, and Fire Departments nationwide to suppress VOC vapors and odors. Many departments report that BioSolve inducted into the sanitary sewers effectively eliminates the explosion hazard when gas leaks into the municipal sewer systems. NOTE: *Always follow State and Federal guidelines and approvals before using in sewers.* We have on file a variety of letters from Fire Depts. and Sanitation Districts regarding this procedure. These are available upon request.

Additional uses: BioSolve is also being utilized in bilge cleaning, vessel cleanups, cutting washers, soil & sludge washing and more.....

Distributed By:

***RG&E***

ROCHESTER GAS & ELECTRIC CORPORATION  
89 East Avenue  
Rochester, New York 14649

## **Appendix K**

# **FIGURES, BORING LOGS, SANBORN MAPS**

**ASSOCIATED WITH THE**

**EAST STATION  
FORMER MANUFACTURED GAS PLANT SITE**

## **Tar Well Removal Work Plan**

**City of Rochester, Monroe County, New York  
VCA Index#: B8-0535-98-07  
Site #: V000358-8**

October 8, 2004

Prepared By:  
RG&E Environmental Affairs

**Figure 1  
Site Location Map**

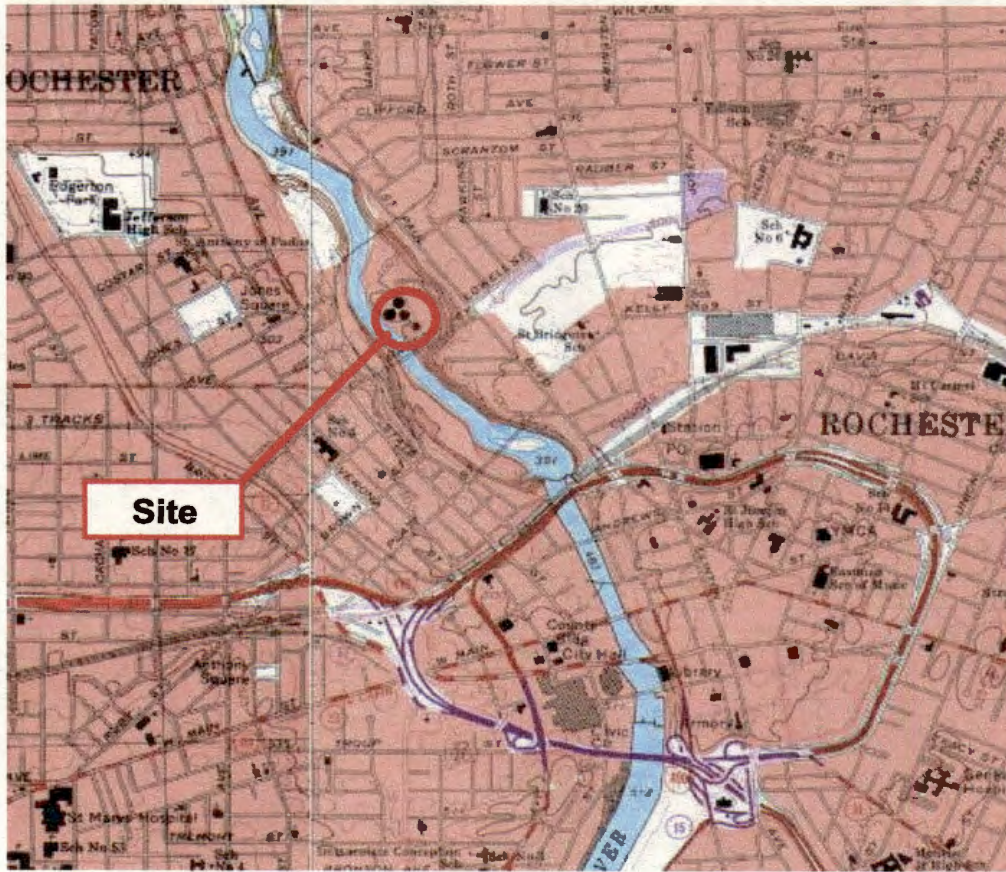

From Rochester, NY 7.5' USGS Topographic Map

0 2000  
Approximate Scale (ft)

**FIGURE 1  
Rochester Gas & Electric  
Former East Station MGP Site Location**

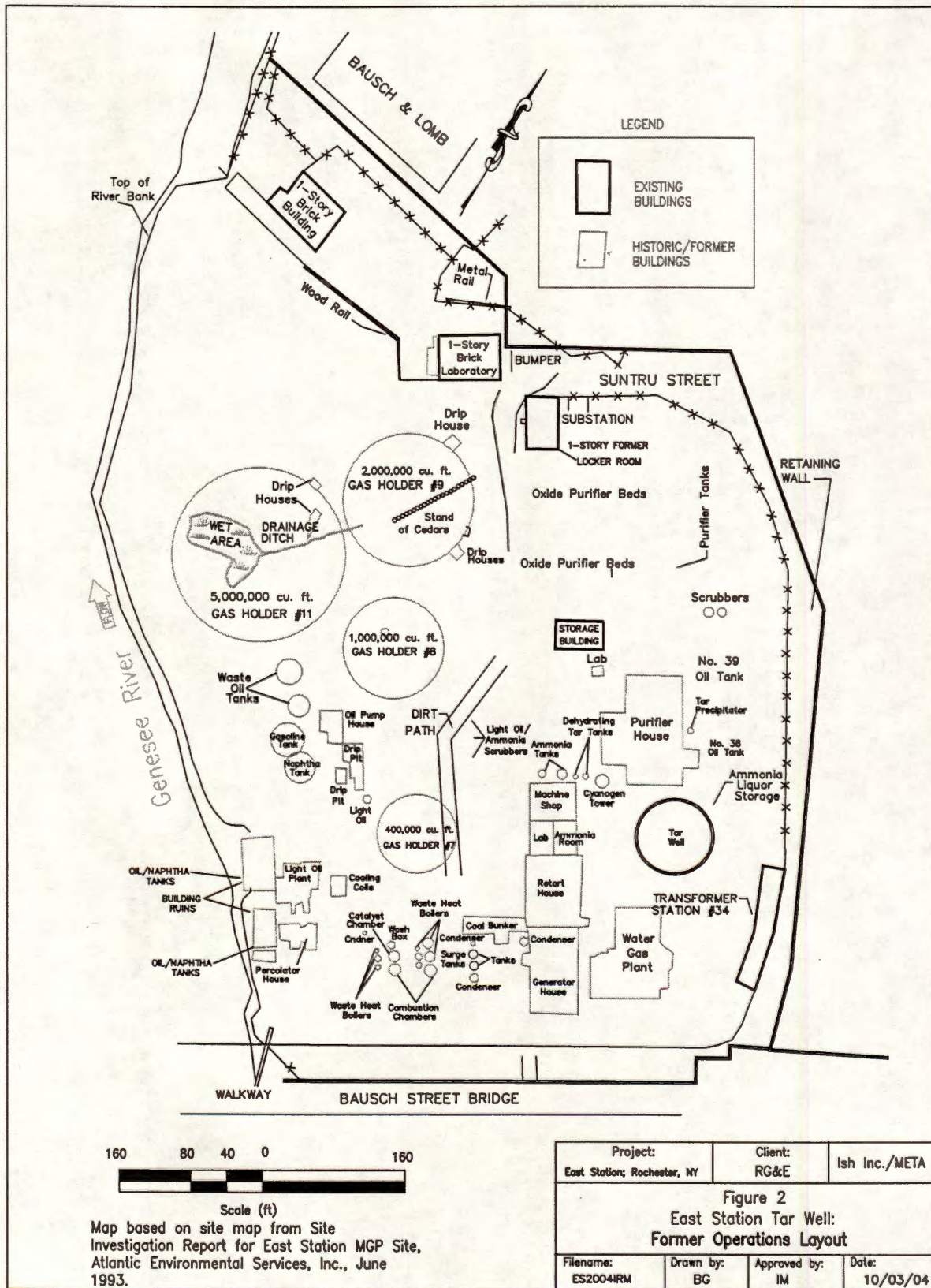

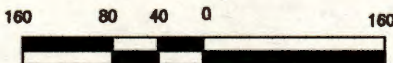
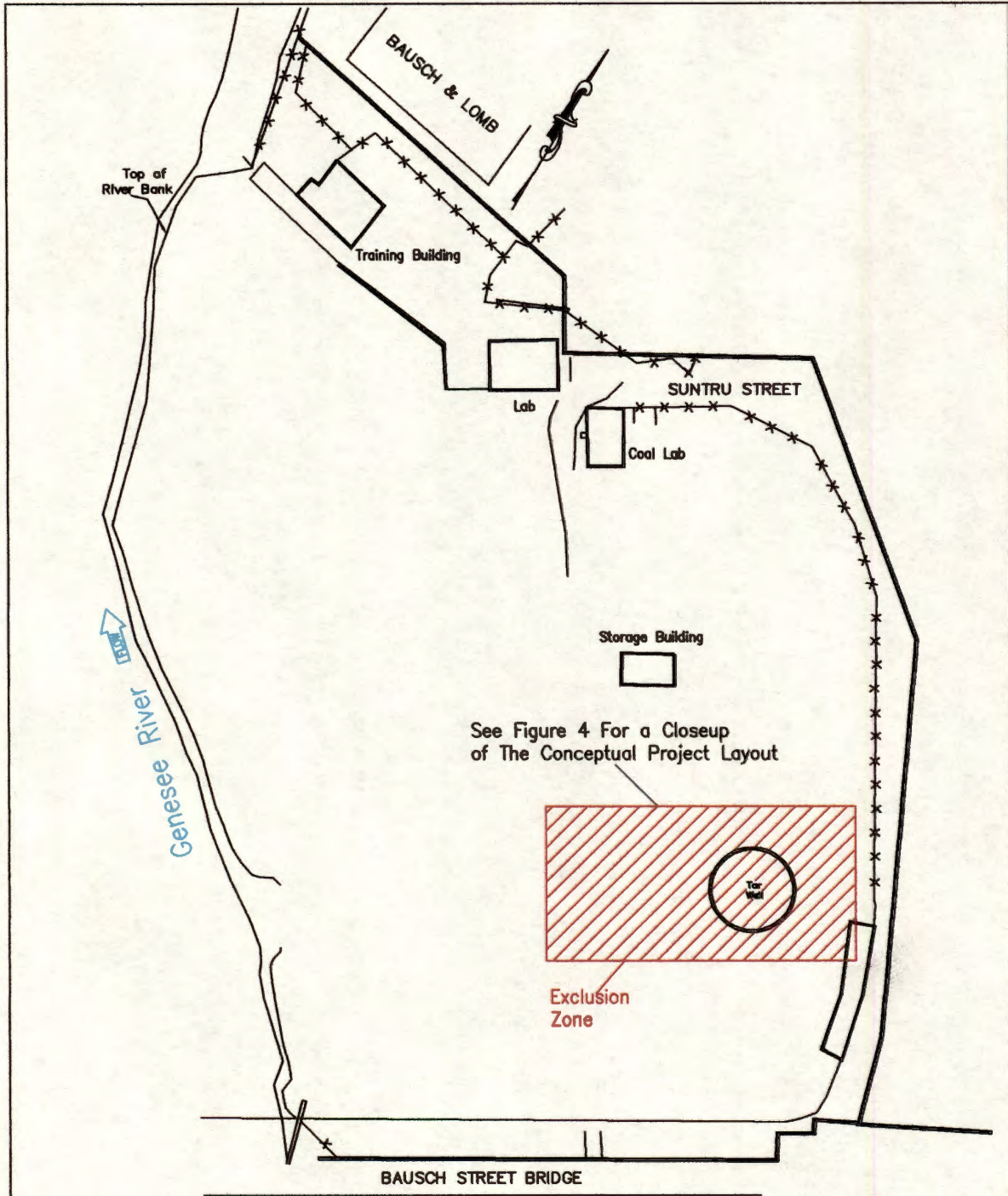

Scale (ft)  
 Map based on site map from Site Investigation Report for East Station MGP Site, Atlantic Environmental Services, Inc., June 1993.

Project: East Station, Rochester, NY	Client: RG&E	Ish Inc./META	
<b>Figure 3</b> <b>East Station Tar Well Removal</b> <b>IRM Work Plan: Exclusion Zone</b>			
Filename: ES2004IRM	Drawn by: BG	Approved by: IM	Date: 10/03/04

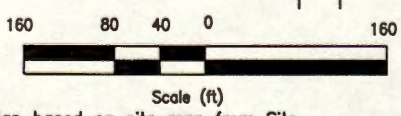
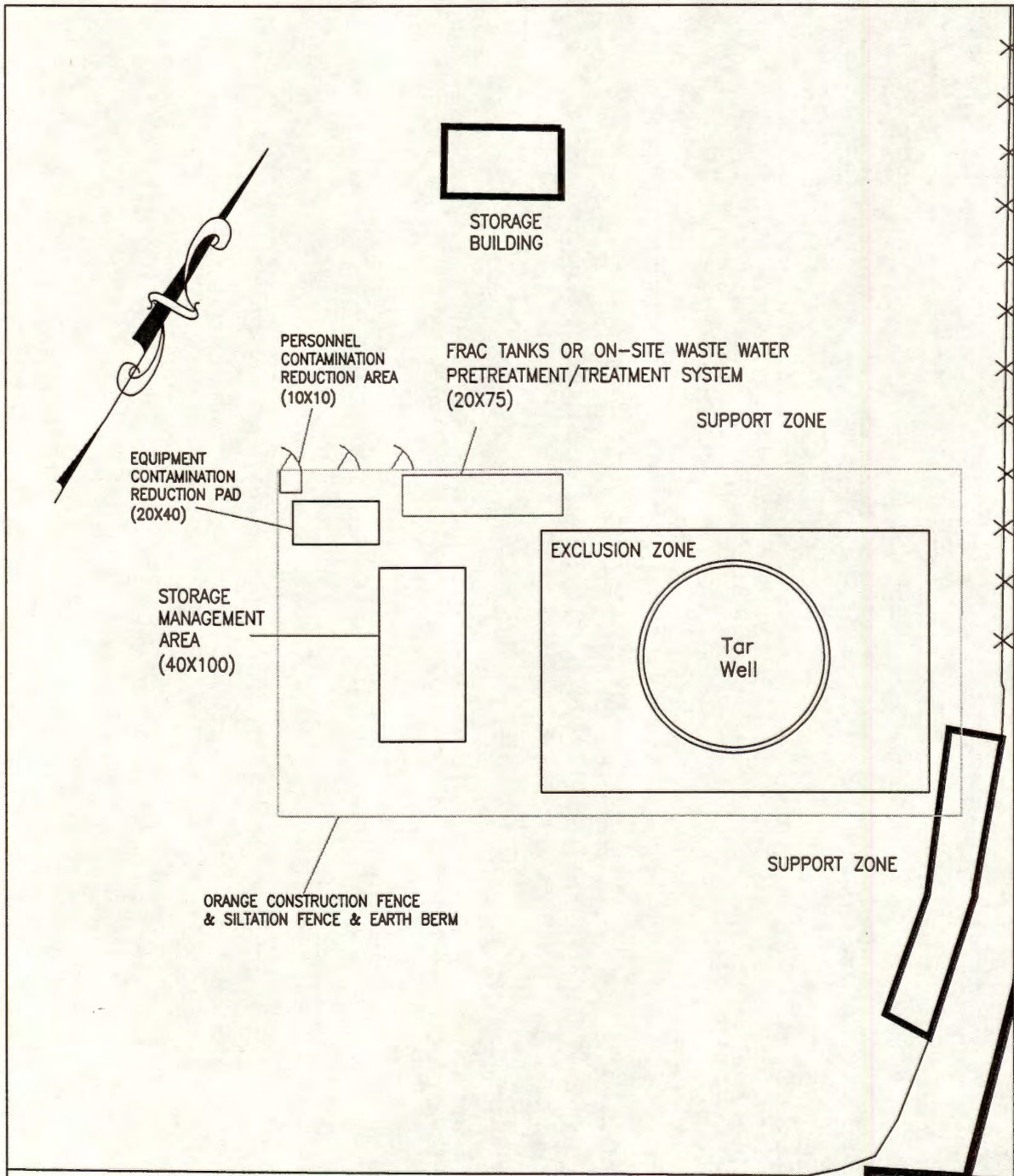

Map based on site map from Site Investigation Report for East Station MGP Site, Atlantic Environmental Services, Inc., June 1993.

Project: East Station, Rochester, NY	Client: RG&E	Ish Inc./META	
Figure 4 Conceptual Layout for the Tar Well Remediation IRM Work Area			
Filename: ES2004IRM	Drawn by: BC	Approved by: IM	Date: 10/03/04

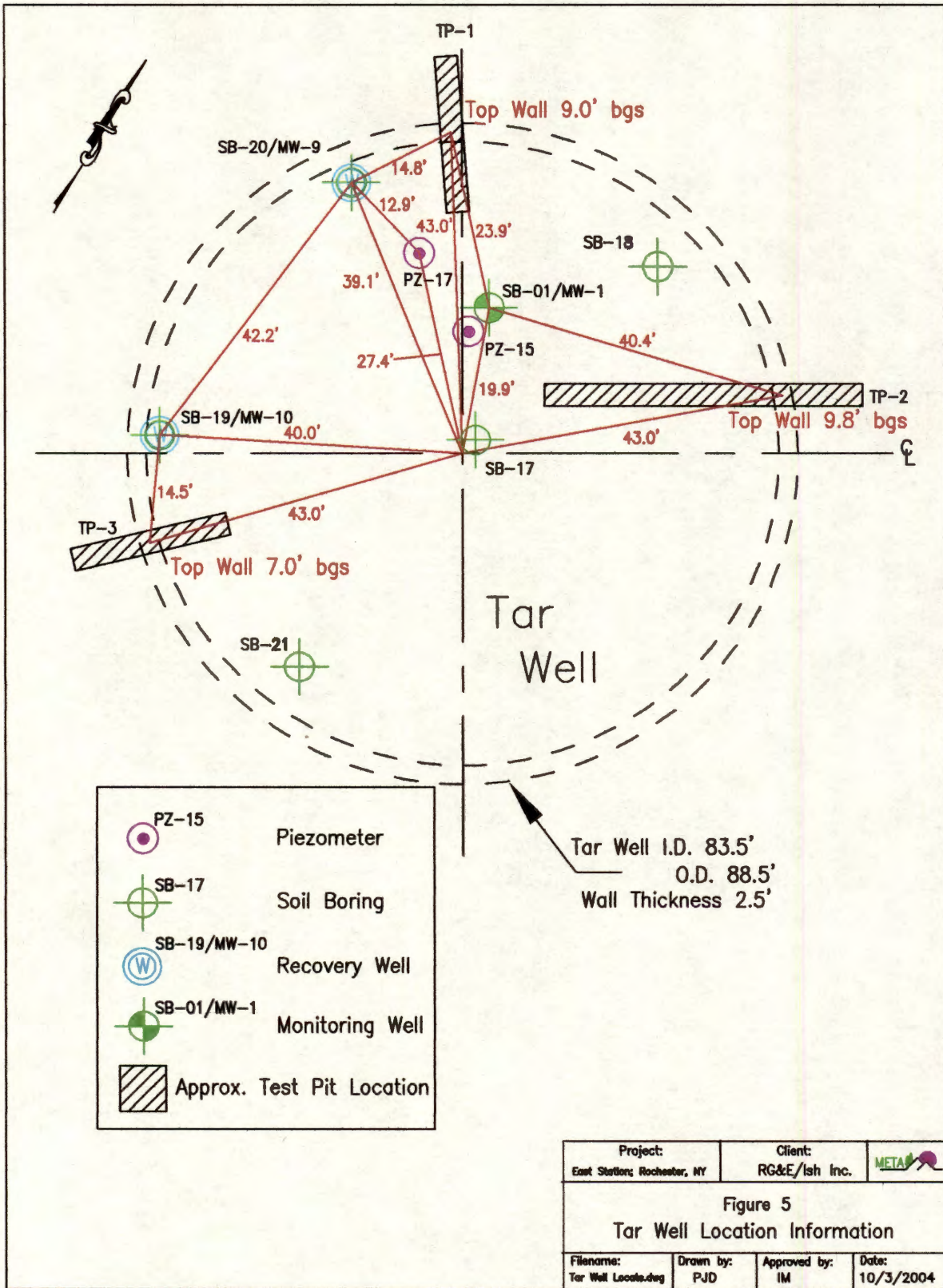

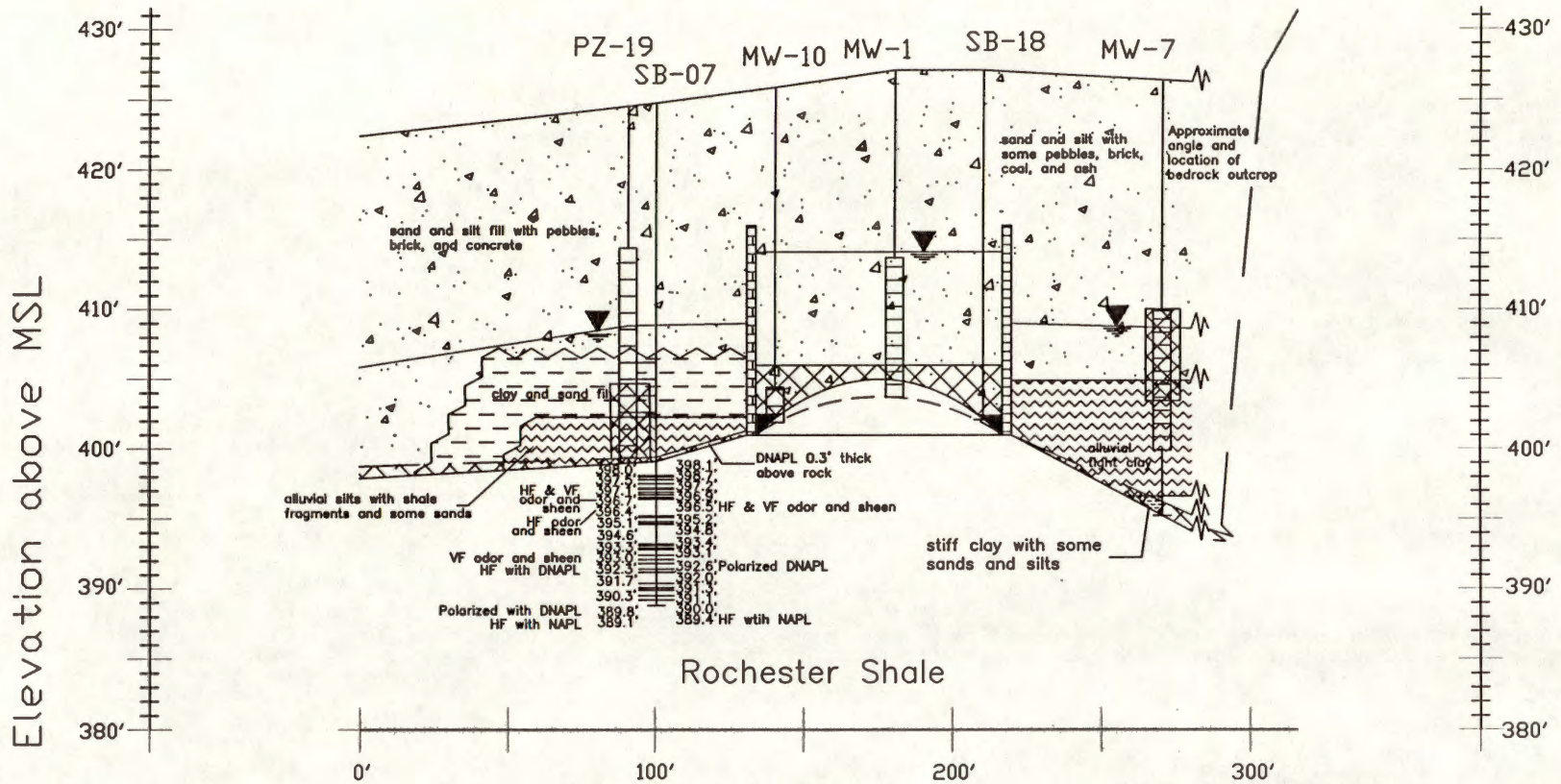

A - A'

Note:  
Elevations of Horizontal Fractures (HF) and Horizontal Cracks (HC) represent fractures with observed odor and sheen unless otherwise noted. Fractures with no impacts are not shown.

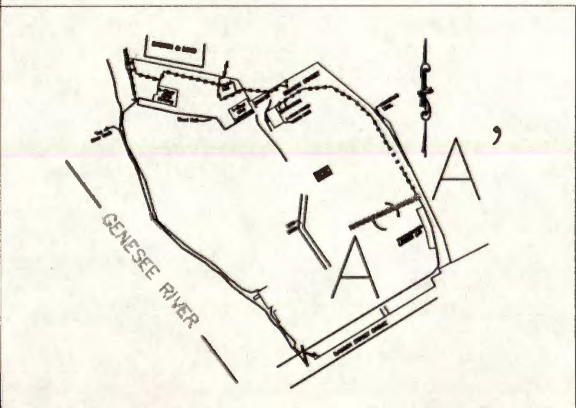

**LEGEND**

Petroleum	Cobble unit
DNAPL TAR	Alluvial Silt & Clay
Fill Sand & Silt	Clay & Sand Fill

Project: East Station Rochester, NY	Client: RG&E	Ish Inc./META	
<b>Figure 6</b> Tar Well Area CROSS SECTION A - A'			
Filename: Tar Well Cross Section.dwg	Drawn by: PJD	Approved by: IM	Date: 10/3/2004



# SB-17

PROJECT: RGSE East Station  
 PROJECT NO.: I03002  
 LOCATION: In center of the tar well  
 DATE STARTED: 11/11/98  
 DATE COMPLETED: 11/11/98  
 DRILLING CONTRACTOR: Lyon Drilling  
 DRILLER: Harry Lyon  
 DRILLING METHOD: 4 1/4" ID Hollow stem auger  
 SAMPLE METHOD: 2"x2' Split spoon sampler, 300# hammer

GROUND ELEVATION: N/A  
 PROTECTIVE CASING ELEVATION: None  
 WELL ELEVATION (TOC): None  
 DEPTH TO WATER: 11.9  
 X-COORDINATE: N/A  
 Y-COORDINATE: N/A  
 WEATHER: Cool and cloudy, 40° F, strong wind 25  
 GEOLOGIST/OBSERVER: Steve Maxwell  
 ENTERED BY: Steve Maxwell

SPLIT SPOON INTERVAL (ft.)	BLOWS PER 0.5 ft.	X RECOVERY	OVH (ppm)	SOIL DESCRIPTION	OBSV.				LITHOLOGY	DEPTH (ft.)	WELL CONSTRUCTION
				moisture, color, fraction, other notes, origin	NONE	ODOR	STAIN	SHEEN			
9.0-11.0	11,11, 14,16	80	0.0	Auger to 9.0'.						0	
				No recovery							5
				Fine SAND with some SILT and pebbles, FILL						10	

# SB-17

PROJECT: RG&E East Station  
 PROJECT NO.: I03002  
 LOCATION: In center of the tar well  
 DATE STARTED: 11/11/98  
 DATE COMPLETED: 11/11/98  
 DRILLING CONTRACTOR: Lyon Drilling  
 DRILLER: Harry Lyon  
 DRILLING METHOD: 4 1/4" ID Hollow stem auger  
 SAMPLE METHOD: 2"x2' Split spoon sampler, 300# hammer

GROUND ELEVATION: N/A  
 PROTECTIVE CASING ELEVATION: None  
 WELL ELEVATION (TOC): None  
 DEPTH TO WATER: 11.9  
 X-COORDINATE: N/A  
 Y-COORDINATE: N/A  
 WEATHER: Cool and cloudy, 40° F, strong wind 25  
 GEOLOGIST/OBSERVER: Steve Maxwell  
 ENTERED BY: Steve Maxwell

SPLIT SPOON INTERVAL (ft.)	BLOWS PER 0.5 ft.	X RECOVERY	OVM (ppm)	SOIL DESCRIPTION  moisture, color, fraction, other notes, origin	OBSV. NONE OOR STAIN SHEEN SAMPLED	LITHOLOGY	DEPTH (ft.)	WELL CONSTRUCTION
11.0-13.0	8.7, 5.7	60	0.0	Fine SAND with some SILT and pebbles, FILL			10	
				Loose, moist SAND with pebbles, coal and clincker ash fragments, FILL				
				No recovery				
13.0-15.0	3.4, 4.7	0.0	0.0	Loose moist to wet SAND with brick and coal fragments, FILL . Water Table (Estimated)				▼
				Loose, saturated coarse SAND and pebbles with coal, brick, and clinker ash fragments, FILL				
				No recovery				
15.0-15.3	50			Thick viscous TAR layer "taffy tar"			15	
				Split spoon and auger refusal, End of Boring TOTAL DEPTH = 15.3'				
							20	

# SB-17B

PROJECT: RG&E East Station  
 PROJECT NO.: I03002  
 LOCATION: About 4' east of SB-17  
 DATE STARTED: 11/11/98  
 DATE COMPLETED: 11/11/98  
 DRILLING CONTRACTOR: Lyon Drilling  
 DRILLER: Harry Lyon  
 DRILLING METHOD: 4 1/4" ID Hollow stem auger  
 SAMPLE METHOD: 2"x2' Split spoon sampler, 300# hammer

GROUND ELEVATION: 425.8  
 PROTECTIVE CASING ELEVATION: None  
 WELL ELEVATION (TOC): None  
 DEPTH TO WATER: 11.9  
 X-COORDINATE: E 757280.0110  
 Y-COORDINATE: N 1155559.6180  
 WEATHER: Cool and cloudy, 40° F, strong wind 25  
 GEOLOGIST/OBSERVER: Steve Maxwell  
 ENTERED BY: Steve Maxwell

SPLIT SPOON INTERVAL (ft.)	BLOWS PER 0.5 ft.	X RECOVERY	OVM (ppm)	SOIL DESCRIPTION	OBSV.				LITHOLOGY	DEPTH (ft.)	WELL CONSTRUCTION
				moisture, color, fraction, other notes, origin	NONE	ODOR	STAIN	SHEEN			
				Augered to 15.0'						0	
										5	
										10	
				Water Table (Estimated)						15	

# SB-17B

PROJECT: RG&E East Station  
 PROJECT NO.: I03002  
 LOCATION: About 4' east of SB-17  
 DATE STARTED: 11/11/98  
 DATE COMPLETED: 11/11/98  
 DRILLING CONTRACTOR: Lyon Drilling  
 DRILLER: Harry Lyon  
 DRILLING METHOD: 4 1/4" ID Hollow stem auger  
 SAMPLE METHOD: 2"x2' Split spoon sampler, 300# hammer

GROUND ELEVATION: 425.8  
 PROTECTIVE CASING ELEVATION: None  
 WELL ELEVATION (TOC): None  
 DEPTH TO WATER: 11.9  
 X-COORDINATE: E 757280.0110  
 Y-COORDINATE: N 1155559.6180  
 WEATHER: Cool and cloudy, 40° F, strong wind 25  
 GEOLOGIST/OBSERVER: Steve Maxwell  
 ENTERED BY: Steve Maxwell

SPLIT SPOON INTERVAL (ft.)	BLOWS PER 0.5 ft.	X RECOVERY	OVM (ppm)	SOIL DESCRIPTION moisture, color, fraction, other notes, origin	OBSV.				LITHOLOGY	DEPTH (ft.)	WELL CONSTRUCTION
					NONE	MOOR	STAIN	SHEEN			
15.0-17.0	2.2 2.2	20		No recovery						15	
17.0-19.0	2.3, 10,12	43	0.7	Loose, saturated course SAND with brick, clinker ash, and concrete, <b>FILL</b>							
				No recovery							
19.0-20.1	7.8, 50	78	0.3 4.3	Loose, saturated course SAND with brick, clinker ash, and concrete fragments, <b>FILL</b>							
			24.2	Loose course <b>FILL</b> with SAND and brick, clinker ash, and concrete fragments							20
				Course <b>FILL</b> saturated with thick plastic <b>TAR</b> "taffy tar"							
				Brick, Bottom of tar well <b>TOTAL DEPTH = 20.1'</b>							
											25
											30

# SB-18B

PROJECT: RG&E East Station  
 PROJECT NO.: I03002  
 LOCATION: 36'NE of center of the tar well  
 DATE STARTED: 11/11/98  
 DATE COMPLETED: 11/11/98  
 DRILLING CONTRACTOR: Lyon Drilling  
 DRILLER: Harry Lyon  
 DRILLING METHOD: 4 1/4" ID Hollow stem auger  
 SAMPLE METHOD: 2"x2' Split spoon sampler, 300# hammer

GROUND ELEVATION: 427.1  
 PROTECTIVE CASING ELEVATION: None  
 WELL ELEVATION (TOC): None  
 DEPTH TO WATER: 14.4  
 X-COORDINATE: E 757296.0150  
 Y-COORDINATE: N 1155588.9540  
 WEATHER: Cool and cloudy, 40° F, strong wind 25  
 GEOLOGIST/OBSERVER: Steve Maxwell  
 ENTERED BY: Steve Maxwell

SPLIT SPOON INTERVAL (ft.)	BLOWS PER 0.5 ft.	X RECOVERY	OVM (ppm)	SOIL DESCRIPTION	OBSV.	LITHOLOGY	DEPTH (ft.)	WELL CONSTRUCTION
				moisture, color, fraction, other notes, origin	NONE ODOR STAIN SHEEN SAMPLED			
				Auger to 9.0'.			0	
9.0-11.0	10,24, 35,50	58	None	No recovery			5	
							10	

# SB-18B

PROJECT: RGSE East Station  
 PROJECT NO.: I03002  
 LOCATION: 36' NE of center of the tar well  
 DATE STARTED: 11/11/98  
 DATE COMPLETED: 11/11/98  
 DRILLING CONTRACTOR: Lyon Drilling  
 DRILLER: Harry Lyon  
 DRILLING METHOD: 4 1/4" ID Hollow stem auger  
 SAMPLE METHOD: 2"x2' Split spoon sampler, 300# hammer

GROUND ELEVATION: 427.1  
 PROTECTIVE CASING ELEVATION: None  
 WELL ELEVATION (TOC): None  
 DEPTH TO WATER: 14.4  
 X-COORDINATE: E 757296.0150  
 Y-COORDINATE: N 1155588.9540  
 WEATHER: Cool and cloudy, 40° F, strong wind 2  
 GEOLOGIST/OBSERVER: Steve Maxwell  
 ENTERED BY: Steve Maxwell

SPLIT SPOON INTERVAL (ft.)	BLOWS PER 0.5 ft.	% RECOVERY	OVM (ppm)	SOIL DESCRIPTION  moisture, color, fraction, other notes, origin	OBSV.			LITHOLOGY	DEPTH (ft.)	WELL CONSTRUCTION
					NONE	ODOR	STAIN			
11.5-13.0	9.8, 7	40		Fine dry SAND and SILT with grey ash, clinker ash, and brick fragments, FILL					10	
				Loose moist SAND with brick and ash fragments, FILL						
				Augered through bricks						
				No recovery						
13.0-15.0	11.6, 6.10	45	None	Brick with concrete cementing					15	
				No recovery						
				Brick and concrete cementing						
15.0-17.0	2.2, 2.3	0		Water Table (Estimated)					15	▼
				Fine saturated grey SAND and black ash fragments, FILL						
				No recovery						
17.0-19.0	2.2, 2.2	30	None	No recovery					20	
				Very course Loose FILL containing, clinker ash, brick, fire brick fragments and SAND with black stain						
19.0-21.0	1.1, 1.1	0		No recovery					20	

# SB-18B

PROJECT: RG&E East Station  
 PROJECT NO.: I03002  
 LOCATION: 36'NE of center of the tar well  
 DATE STARTED: 11/11/98  
 DATE COMPLETED: 11/11/98  
 DRILLING CONTRACTOR: Lyon Drilling  
 DRILLER: Harry Lyon  
 DRILLING METHOD: 4 1/4" ID Hollow stem auger  
 SAMPLE METHOD: 2"x2' Split spoon sampler, 300# hammer

GROUND ELEVATION: 427.1  
 PROTECTIVE CASING ELEVATION: None  
 WELL ELEVATION (TOC): None  
 DEPTH TO WATER: 14.4  
 X-COORDINATE: E 757296.0150  
 Y-COORDINATE: N 1155588.9540  
 WEATHER: Cool and cloudy, 40° F, strong wind 25  
 GEOLOGIST/OBSERVER: Steve Maxwell  
 ENTERED BY: Steve Maxwell

SPLIT SPOON INTERVAL (ft.)	BLOWS PER 0.5 ft.	X RECOVERY	OVM (ppm)	SOIL DESCRIPTION  moisture, color, fraction, other notes, origin	OBSV.			LITHOLOGY	DEPTH (ft.)	WELL CONSTRUCTION
					NONE	ODOR	STAIN SHEEN			
21.0-23.0	1,3, 6,5	25	None	No recovery				20		
23.0-25.0	1,5, 6,7	50		Very loose FILL containing brick, ash, and coal fragments with flowing TAR No recovery						
				Course FILL with thick plastic TAR "taffy tar"						
				Brick, Bottom of tar well, End of Boring. TOTAL DEPTH = 25.0'				25		
								30		

# SB-19/MW-10

PROJECT: RG&E East Station  
 PROJECT NO.: I03002  
 LOCATION: 40' South of center of tar well  
 DATE STARTED: 11/11/98  
 DATE COMPLETED: 11/11/98  
 DRILLING CONTRACTOR: Lyon Drilling  
 DRILLER: Harry Lyon  
 DRILLING METHOD: 4 1/4" ID Hollow stem auger  
 SAMPLE METHOD: 2"x2" Split spoon sampler, 300# hammer

GROUND ELEVATION: 425.9  
 PROTECTIVE CASING ELEVATION: 428.46  
 WELL ELEVATION (TOC): N/A  
 DEPTH TO WATER: 12.1  
 X-COORDINATE: E 757240.0700  
 Y-COORDINATE: N 1155547.7110  
 WEATHER: Cool and cloudy, 40° F, strong wind 2:  
 GEOLOGIST/OBSERVER: Steve Maxwell  
 ENTERED BY: Steve Maxwell

SPLIT SPOON INTERVAL (ft.)	BLOCKS PER 0.5 ft.	% RECOVERY	OVN (ppm)	SOIL DESCRIPTION	OBSV.				LITHOLOGY	DEPTH (ft.)	WELL CONSTRUCTION
				moisture, color, fraction, other notes, origin	NONE	ODOR	STAIN	SHEEN			
				Augered to 9.0'						0	<p style="font-size: small;">             5" Locking Steel Guard Pipe              Well Cap              Concrete              Bentonite Grout              Bentonite Grout              4" PVC Riser to 2.5' Above Grade           </p>
										5	



# SB-19/MW-10

PROJECT: RG&E East Station  
 PROJECT NO.: IO3002  
 LOCATION: 40' South of center of tar well  
 DATE STARTED: 11/11/98  
 DATE COMPLETED: 11/11/98  
 DRILLING CONTRACTOR: Lyon Drilling  
 DRILLER: Harry Lyon  
 DRILLING METHOD: 4 1/4" ID Hollow stem auger  
 SAMPLE METHOD: 2"x2" Split spoon sampler, 300# hammer

GROUND ELEVATION: 425.9  
 PROTECTIVE CASING ELEVATION: 428.46  
 WELL ELEVATION (TOC): N/A  
 DEPTH TO WATER: 12.1  
 X-COORDINATE: E 757240.0700  
 Y-COORDINATE: N 1155547.7110  
 WEATHER: Cool and cloudy, 40° F, strong wind 25  
 GEOLOGIST/OBSERVER: Steve Maxwell  
 ENTERED BY: Steve Maxwell

SPLIT SPOON INTERVAL (ft.)	BLOWS PER 0.5 ft.	% RECOVERY	OVM (ppm)	SOIL DESCRIPTION	OBSV.	LITHOLOGY	DEPTH (ft.)	WELL CONSTRUCTION
				moisture, color, fraction, other notes, origin	NONE ODOR STAIN SHEEN SAMPLED			
				Augered to 9.0'			5	<p style="margin-left: 20px;">4" PVC Riser to 2.5' Above Grade</p> <p style="margin-left: 20px;">Bentonite Grout</p>
9.0-11.0	3,7, 5,4	80	None	No recovery			10	
				Firm, fine brown SAND with pebbles, brick, ash, and concrete fragments FILL				

# SB-19/MW-10

PROJECT: RG&E East Station  
 PROJECT NO.: I03002  
 LOCATION: 40' South of center of tar well  
 DATE STARTED: 11/11/98  
 DATE COMPLETED: 11/11/98  
 DRILLING CONTRACTOR: Lyon Drilling  
 DRILLER: Harry Lyon  
 DRILLING METHOD: 4 1/4" ID Hollow stem auger  
 SAMPLE METHOD: 2"x2" Split spoon sampler, 300# hammer

GROUND ELEVATION: 425.9  
 PROTECTIVE CASING ELEVATION: 428.46  
 WELL ELEVATION (TOC): N/A  
 DEPTH TO WATER: 12.1  
 X-COORDINATE: E 757240.0700  
 Y-COORDINATE: N 1155547.7110  
 WEATHER: Cool and cloudy, 40° F, strong wind 25  
 GEOLOGIST/OBSERVER: Steve Maxwell  
 ENTERED BY: Steve Maxwell

SPLIT SPOON INTERVAL (ft.)	BLOWS PER 0.5 ft.	X RECOVERY	OVM (ppm)	SOIL DESCRIPTION moisture, color, fraction, other notes, origin	OBSV.			LITHOLOGY	DEPTH (ft.)	WELL CONSTRUCTION
					NONE	ODOR	STAIN			
11.0-13.0	4,3, 3,1	70		Loose, dry SAND with pebbles, brick, and ash fragments, FILL  No recovery  Loose, wet to saturated coarse SAND with clinker ash and brick fragments, FILL  Water Table (Estimated)	NONE	ODOR	STAIN	SAMPLED	10	4" PVC Riser to 2.5' Above Grade  Bentonite Grout
13.0-15.0	2,1, 1,2	25	None	No recovery    Course saturated coarse SAND with clinker ash, brick, and concrete fragments, FILL	NONE	ODOR	STAIN	SAMPLED	15	Bentonite Seal

# SB-19/MW-10

PROJECT: RG&E East Station  
 PROJECT NO.: 103002  
 LOCATION: 40' South of center of tar well  
 DATE STARTED: 11/11/98  
 DATE COMPLETED: 11/11/98  
 DRILLING CONTRACTOR: Lyon Drilling  
 DRILLER: Harry Lyon  
 DRILLING METHOD: 4 1/4" ID Hollow stem auger  
 SAMPLE METHOD: 2"x2' Split spoon sampler, 300# hammer

GROUND ELEVATION: 425.9  
 PROTECTIVE CASING ELEVATION: 428.46  
 WELL ELEVATION (TOC): N/A  
 DEPTH TO WATER: 12.1  
 X-COORDINATE: E 757240.0700  
 Y-COORDINATE: N 1155547.7110  
 WEATHER: Cool and cloudy, 40° F, strong wind 25  
 GEOLOGIST/OBSERVER: Steve Maxwell  
 ENTERED BY: Steve Maxwell

SPLIT SPOON INTERVAL (ft.)	BLOWS PER 0.5 ft.	% RECOVERY	OVH (ppm)	SOIL DESCRIPTION  moisture, color, fraction, other notes, origin	OBSV.			LITHOLOGY	DEPTH (ft.)	WELL CONSTRUCTION
					NONE	ODOR	STAIN			
15.0-17.0	3,1 1,1	15		No recovery				15		
17.0-19.0	2,1 2,1	20	None	Loose, saturated coarse FILL containing clinker ash, concrete fragments, and SAND No recovery				15		
19.0-21.0	1 for 1',1, 1	30		Loose coarse FILL containing clinker ash, brick fragments and SAND No recovery				20		

# SB-19/MW-10

PROJECT: RG&E East Station  
 PROJECT NO.: 103002  
 LOCATION: 40' South of center of tar well  
 DATE STARTED: 11/11/98  
 DATE COMPLETED: 11/11/98  
 DRILLING CONTRACTOR: Lyon Drilling  
 DRILLER: Harry Lyon  
 DRILLING METHOD: 4 1/4" ID Hollow stem auger  
 SAMPLE METHOD: 2"x2' Split spoon sampler, 300# hammer

GROUND ELEVATION: 425.9  
 PROTECTIVE CASING ELEVATION: 428.46  
 WELL ELEVATION (TOC): N/A  
 DEPTH TO WATER: 12.1  
 X-COORDINATE: E 757240.0700  
 Y-COORDINATE: N 1155547.7110  
 WEATHER: Cool and cloudy, 40° F, strong wind 25  
 GEOLOGIST/OBSERVER: Steve Maxwell  
 ENTERED BY: Steve Maxwell

SPLIT SPOON INTERVAL (ft.)	BLOWS PER 0.5 ft.	X RECOVERY	OVH (ppm)	SOIL DESCRIPTION  moisture, color, fraction, other notes, origin	OBSV.			LITHOLOGY	DEPTH (ft.)	WELL CONSTRUCTION
					NONE	ODOR	STAIN			
21.0-23.0	1,6, 8,11	25	None	Loose, saturated coarse FILL containing clinker ash and TAR  No recovery					20	4" PVC Riser to 2.5' Above Grade  3/4" Gravel Pack
23.0-24.0	5,7	100		Coarse SAND FILL with clinker ash and viscous flowing TAR  Soft brick with viscous flowing TAR Coarse SAND with clinker ash, brick fragments, and viscous flowing TAR, FILL Dense plastic TAR "taffy tar"						0.030" Slotted Screen w/ 1/8" Holes  Well Cap
				Brick, Bottom of tar well, End of Boring TOTAL DEPTH = 24.0'					25	End on Well Screen

# SB-20/MW-9

PROJECT: RG&E East Station  
 PROJECT NO.: I03002  
 LOCATION: 39' North of center of tar well  
 DATE STARTED: 11/12/98  
 DATE COMPLETED: 11/12/98  
 DRILLING CONTRACTOR: Lyon Drilling  
 DRILLER: Harry Lyon  
 DRILLING METHOD: 4 1/4" ID Hollow stem auger  
 SAMPLE METHOD: 2"x2" Split spoon sampler, 300# hammer

GROUND ELEVATION: 426.4  
 PROTECTIVE CASING ELEVATION: N/A  
 WELL ELEVATION (TOC): 429.01  
 DEPTH TO WATER: 12.9  
 X-COORDINATE: E 757254.1260  
 Y-COORDINATE: N 1155587.4970  
 WEATHER: Clear and cool 40° F, 5-10 mph wind  
 GEOLOGIST/OBSERVER: Steve Maxwell  
 ENTERED BY: Steve Maxwell

SPLIT SPOON INTERVAL (ft.)	BLOWS PER 0.5 ft.	X RECOVERY	OVM (ppm)	SOIL DESCRIPTION	OBSV.				LITHOLOGY	DEPTH (ft.)	WELL CONSTRUCTION	
				moisture, color, fraction, other notes, origin	NONE	ODOR	STAIN	SHEEN			SAMPLED	6"
				Augered to 9.0'						0		
										5		

# SB-20/MW-9

PROJECT: RG&E East Station  
 PROJECT NO.: IO3002  
 LOCATION: 39' North of center of tar well  
 DATE STARTED: 11/12/98  
 DATE COMPLETED: 11/12/98  
 DRILLING CONTRACTOR: Lyon Drilling  
 DRILLER: Harry Lyon  
 DRILLING METHOD: 4 1/4" ID Hollow stem auger  
 SAMPLE METHOD: 2"x2" Split spoon sampler, 300# hammer

GROUND ELEVATION: 426.4  
 PROTECTIVE CASING ELEVATION: N/A  
 WELL ELEVATION (TOC): 429.01  
 DEPTH TO WATER: 12.9  
 X-COORDINATE: E 757254.1260  
 Y-COORDINATE: N 1155587.4970  
 WEATHER: Clear and cool 40° F, 5-10 mph wind  
 GEOLOGIST/OBSERVER: Steve Maxwell  
 ENTERED BY: Steve Maxwell

SPLIT SPOON INTERVAL (ft.)	BLOWS PER 0.5 ft.	X RECOVERY	OVN (ppm)	SOIL DESCRIPTION moisture, color, fraction, other notes, origin	OBSV.				LITHOLOGY	DEPTH (ft.)	WELL CONSTRUCTION
					NONE	ODOR	STAIN	SHEEN			
				Augered to 9.0'							<p style="text-align: right;">4" PVC Riser to 2.5' Above Grade</p> <p style="text-align: right;">Bentonite Grout</p>
9.0-11.0	5,12, 8,7	85	None	No recovery							
				Dry brown SAND with pebbles, coal and brick fragments, FILL							

# SB-20/MW-9

PROJECT: RG&E East Station  
 PROJECT NO.: 103002  
 LOCATION: 39' North of center of tar well  
 DATE STARTED: 11/12/98  
 DATE COMPLETED: 11/12/98  
 DRILLING CONTRACTOR: Lyon Drilling  
 DRILLER: Harry Lyon  
 DRILLING METHOD: 4 1/4" ID Hollow stem auger  
 SAMPLE METHOD: 2"x2" Split spoon sampler, 300# hammer

GROUND ELEVATION: 426.4  
 PROTECTIVE CASING ELEVATION: N/A  
 WELL ELEVATION (TOC): 429.01  
 DEPTH TO WATER: 12.9  
 X-COORDINATE: E 757254.1260  
 Y-COORDINATE: N 1155587.4970  
 WEATHER: Clear and cool 40° F, 5-10 mph wind  
 GEOLOGIST/OBSERVER: Steve Maxwell  
 ENTERED BY: Steve Maxwell

SPLIT SPOON INTERVAL (ft.)	BLOWS PER 0.5 ft.	% RECOVERY	OVH (ppm)	SOIL DESCRIPTION moisture, color, fraction, other notes, origin	OBSV.			LITHOLOGY	DEPTH (ft.)	WELL CONSTRUCTION
					NONE	ODOR	STAIN			
11.0-13.0	5.9, 3.2	40		Loose, dry, black SAND with clinker ash, coal, and brick fragments, FILL					10	4" PVC Riser to 2.5' Above Grade
				No recovery						Bentonite Grout
13.0-15.0	2.1, 1.1	0	None	Loose, black SAND with clinker ash, brick, fire brick and SHALE fragments, FILL						
				Water Table (Estimated)						▼
				No recovery					15	Bentonite Seal

# SB-20/MW-9

PROJECT: RG&E East Station  
 PROJECT NO.: I03002  
 LOCATION: 39' North of center of tar well  
 DATE STARTED: 11/12/98  
 DATE COMPLETED: 11/12/98  
 DRILLING CONTRACTOR: Lyon Drilling  
 DRILLER: Harry Lyon  
 DRILLING METHOD: 4 1/4" ID Hollow stem auger  
 SAMPLE METHOD: 2"x2' Split spoon sampler, 300# hammer

GROUND ELEVATION: 426.4  
 PROTECTIVE CASING ELEVATION: N/A  
 WELL ELEVATION (TOC): 429.01  
 DEPTH TO WATER: 12.9  
 X-COORDINATE: E 757254.1260  
 Y-COORDINATE: N 1155587.4970  
 WEATHER: Clear and cool 40° F, 5-10 mph wind  
 GEOLOGIST/OBSERVER: Steve Maxwell  
 ENTERED BY: Steve Maxwell

SPLIT SPOON INTERVAL (ft.)	BLOWS PER 0.5 ft.	% RECOVERY	OVH (ppm)	SOIL DESCRIPTION moisture, color, fraction, other notes, origin	OBSV.			LITHOLOGY	DEPTH (ft.)	WELL CONSTRUCTION
					NONE	ODOR	STAIN			
15.0-17.0	2,1, 1 for 1'	25							15	Bentonite Seal
				Loose FILL with SAND, brick, clinker ash, wood fragments, sheen, and odor						4" PVC Riser to 2.5' Above Grade
17.0-19.0	1,1, 1,1	25	None	No recovery						3/4" Gravel Pack
				Loose saturated FILL with SAND, brick fragments, sheen, and odor						
19.0-21.0	1, 1 for 1',2	20		No recovery					20	



# SB-20/MW-9

PROJECT: RG&E East Station  
 PROJECT NO.: I03002  
 LOCATION: 39' North of center of tar well  
 DATE STARTED: 11/12/98  
 DATE COMPLETED: 11/12/98  
 DRILLING CONTRACTOR: Lyon Drilling  
 DRILLER: Harry Lyon  
 DRILLING METHOD: 4 1/4" ID Hollow stem auger  
 SAMPLE METHOD: 2"x2" Split spoon sampler, 300# hammer

GROUND ELEVATION: 426.4  
 PROTECTIVE CASING ELEVATION: N/A  
 WELL ELEVATION (TOC): 429.01  
 DEPTH TO WATER: 12.9  
 X-COORDINATE: E 757254.1260  
 Y-COORDINATE: N 1155587.4970  
 WEATHER: Clear and cool 40° F, 5-10 mph wind  
 GEOLOGIST/OBSERVER: Steve Maxwell  
 ENTERED BY: Steve Maxwell

SPLIT SPOON INTERVAL (ft.)	BLOWS PER 0.5 ft.	X RECOVERY	OVM (ppm)	SOIL DESCRIPTION  moisture, color, fraction, other notes, origin	OBSV.				LITHOLOGY	DEPTH (ft.)	WELL CONSTRUCTION
					NONE	ODOR	STAIN	SHEEN			
21.0-23.0	1,1 1,1	15	None	Loose saturated coarse FILL containing brick, clinker ash, and flowing TAR  No recovery							4" PVC Riser to 2.5' Above Grade
23.0-24.1	1,5, 50	100		Loose, Coarse SAND FILL with clinker ash and soft flowing TAR  Dense plastic TAR, "taffy tar"							3/4" Gravel Pack
				Brick, Bottom of tar well, End of Boring TOTAL DEPTH = 24.1'							0.030" Slotted Screen w/ 1/8" Holes
											Well Cap
											End on Well Screen

# SB-21

PROJECT: RG&E East Station  
 PROJECT NO.: I03002  
 LOCATION: 39' SSE of center of the tar well  
 DATE STARTED: 11/12/98  
 DATE COMPLETED: 11/12/98  
 DRILLING CONTRACTOR: Lyon Drilling  
 DRILLER: Harry Lyon  
 DRILLING METHOD: 4 1/4" ID Hollow stem auger  
 SAMPLE METHOD: 2"x2' Split spoon sampler, 300# hammer

GROUND ELEVATION: 419.1  
 PROTECTIVE CASING ELEVATION: None  
 WELL ELEVATION (TOC): None  
 DEPTH TO WATER: 5.1  
 X-COORDINATE: E 757266.8800  
 Y-COORDINATE: N 1155523.7300  
 WEATHER: Clear and cool 40° F, 5-10 mph wind  
 GEOLOGIST/OBSERVER: Steve Maxwell  
 ENTERED BY: Steve Maxwell

SPLIT SPOON INTERVAL (ft.)	BLOWS PER 0.5 ft.	% RECOVERY	OVM (ppm)	SOIL DESCRIPTION	OBSV.			LITHOLOGY	DEPTH (ft.)	WELL CONSTRUCTION
				moisture, color, fraction, other notes, origin	NONE	ODOR	STAIN			
3.0-5.0	3.5, 8,12	65	None	Augered to 3.0'					0	
				No recovery						
				Loose, black SAND with pebbles, brick, clinker ash, and coal fragments FILL					5	
				Dry pulverized brick						
				Loose, wet black SAND with clinker ash and brick fragments. FILL with black stain						

# SB-21

PROJECT: RG&E East Station  
 PROJECT NO.: IO3002  
 LOCATION: 39' SSE of center of the tar well  
 DATE STARTED: 11/12/98  
 DATE COMPLETED: 11/12/98  
 DRILLING CONTRACTOR: Lyon Drilling  
 DRILLER: Harry Lyon  
 DRILLING METHOD: 4 1/4" ID Hollow stem auger  
 SAMPLE METHOD: 2"x2' Spilt spoon sampler, 300# hammer

GROUND ELEVATION: 419.1  
 PROTECTIVE CASING ELEVATION: None  
 WELL ELEVATION (TOC): None  
 DEPTH TO WATER: 5.1  
 X-COORDINATE: E 757266.8800  
 Y-COORDINATE: N 1155523.7300  
 WEATHER: Clear and cool 40° F, 5-10 mph wind  
 GEOLOGIST/OBSERVER: Steve Maxwell  
 ENTERED BY: Steve Maxwell

SPLIT SPOON INTERVAL (ft.)	BLOWS PER 0.5 ft.	% RECOVERY	OVM (ppm)	SOIL DESCRIPTION	OBSV.			LITHOLOGY	DEPTH (ft.)	WELL CONSTRUCTION
				moisture, color, fraction, other notes, origin	NONE	ODOR	STAIN			
5.0-7.0	1,1 1,1	35		No recovery. Water Table (Estimated)					5	▼
				Saturated loose FILL with SAND concrete, coal, clinker ash, brick fragments, odor, and black stain						
7.0-9.0	wt of Rod, 1,2	40	None	No recovery						
				Loose, saturated black SAND with coal brick fragments, shen, and odor. FILL						
9.0-11.0	1,1 4,8	40	None	No recovery					10	

# SB-21

PROJECT: RG&E East Station  
 PROJECT NO.: I03002  
 LOCATION: 39' SSE of center of the tar well  
 DATE STARTED: 11/12/98  
 DATE COMPLETED: 11/12/98  
 DRILLING CONTRACTOR: Lyon Drilling  
 DRILLER: Harry Lyon  
 DRILLING METHOD: 4 1/4" ID Hollow stem auger  
 SAMPLE METHOD: 2"x2' Split spoon sampler, 300# hammer

GROUND ELEVATION: 419.1  
 PROTECTIVE CASING ELEVATION: None  
 WELL ELEVATION (TOC): None  
 DEPTH TO WATER: 5.1  
 X-COORDINATE: E 757266.8800  
 Y-COORDINATE: N 1155523.7300  
 WEATHER: Clear and cool 40° F. 5-10 mph wind  
 GEOLOGIST/OBSERVER: Steve Maxwell  
 ENTERED BY: Steve Maxwell

SPLIT SPOON INTERVAL (ft.)	BLOWS PER 0.5 ft.	x RECOVERY	OVM (ppm)	SOIL DESCRIPTION moisture, color, fraction, other notes, origin	OBSV.			LITHOLOGY	DEPTH (ft.)	WELL CONSTRUCTION
					NONE	ODOR	STAIN			
11.0-13.0	1,1, 6,8	45		Loose saturated FILL with SAND, clinker ash, concrete, brick fragments, and odor					10	
				No recovery						
13.0-15.0	4,3, 6,4	40	None	Loose FILL with SAND, coal, clinker ash, and brick fragments					15	
				No recovery						
				Loose FILL with SAND, clinker ash, coal, brick fragments and flowing TAR						

# SB-21

PROJECT: RG&E East Station  
 PROJECT NO.: I03002  
 LOCATION: 39' SSE of center of the tar well  
 DATE STARTED: 11/12/98  
 DATE COMPLETED: 11/12/98  
 DRILLING CONTRACTOR: Lyon Drilling  
 DRILLER: Harry Lyon  
 DRILLING METHOD: 4 1/4" ID Hollow stem auger  
 SAMPLE METHOD: 2"x2' Split spoon sampler, 300# hammer

GROUND ELEVATION: 419.1  
 PROTECTIVE CASING ELEVATION: None  
 WELL ELEVATION (TOC): None  
 DEPTH TO WATER: 5.1  
 X-COORDINATE: E 757266.8800  
 Y-COORDINATE: N 1155523.7300  
 WEATHER: Clear and cool 40° F, 5-10 mph wind  
 GEOLOGIST/OBSERVER: Steve Maxwell  
 ENTERED BY: Steve Maxwell

SPLIT SPOON INTERVAL (ft.)	BLOWS PER 0.5 ft.	X RECOVERY	OVM (ppm)	SOIL DESCRIPTION	OBSV.			LITHOLOGY	DEPTH (ft.)	WELL CONSTRUCTION
				moisture, color, fraction, other notes, origin	NONE	ODOR	STAIN			
15.0-16.7	1,4, 3,50	47		No recovery					15	
				Loose FILL with clinker ash, coal, concrete, and soft flowing TAR						
				Thick, heavy, plastic TAR, "taffy tar"						
				Brick, Bottom of tar well						
				End of Boring TOTAL DEPTH = 16.7'						
									20	

Appendix B  
**Test Pit Logs**

# TEST PIT DESCRIPTION SHEET

PROJECT NUMBER: I03002-51  
 PROJECT: META-EPRI/ RG&E  
 SITE: East Station MGP  
 TEST PIT ID: TP-3  
 LOCATION: South west side of circular tar well  
 PURPOSE: To aerially and vertically locate the tar well wall  
 DATE: 11/6/98  
 TIME: 4:00 pm  
 WEATHER: overcast, low 50s°F

OBSERVER: C. Jones  
 ASSISTANT: K. Hylton  
 OTHER: none  
 EXCAVATOR: RG&E Operator  
 EQUIPMENT: Backhoe: CASE Extended Arm  
 LOCAL UTILITY CLEARANCE: J. Meehan (RG&E)  
 DEPTH TO GROUNDWATER: not encountered  
 TOTAL DEPTH: 9.0 feet  
 NAPL PRESENT: no

## TEST PIT 3

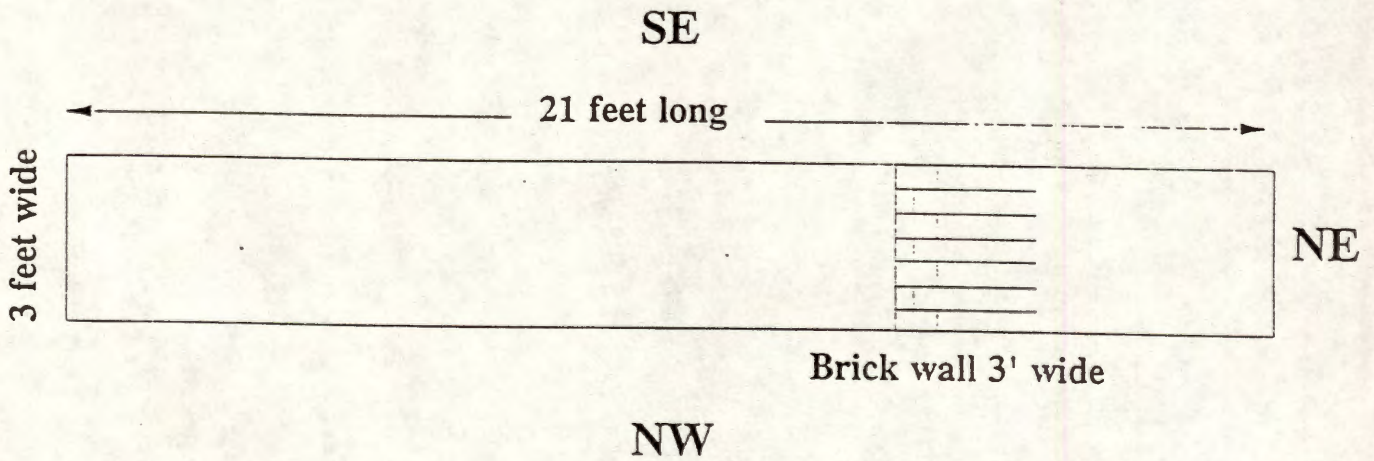

### Test Pit Stratigraphy

0' - 9.0' Fill comprised of ash, clinker, silts, sands, brick, concrete rubble, piping, and asphalt

@ 7.0' Top of tar well wall made of brick. Approximately 3' wide.

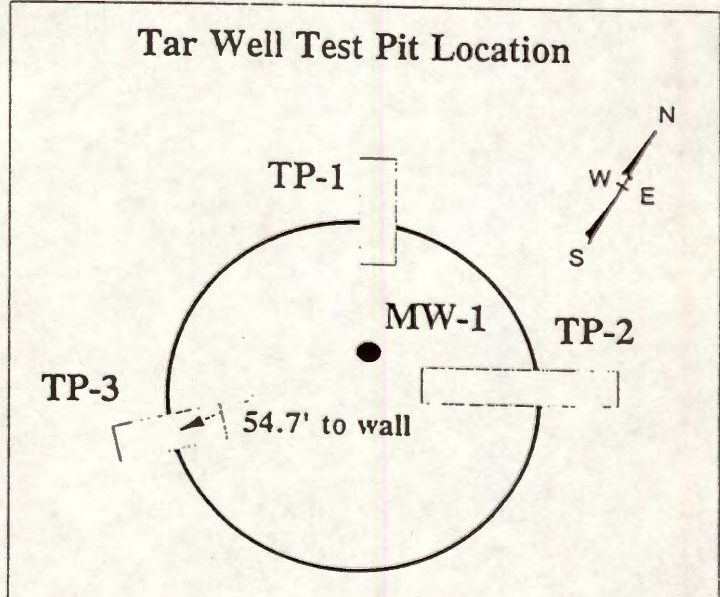

# TEST PIT DESCRIPTION SHEET

PROJECT NUMBER: 103002-51  
 PROJECT: META-EPRI/ RG&E  
 SITE: East Station MGP  
 TEST PIT ID: TP-2  
 LOCATION: East side of circular tar well  
 PURPOSE: To aerially and vertically locate the tar well wall  
 DATE: 11/6/98  
 TIME: 1:00 pm  
 WEATHER: overcast, low 50s°F

OBSERVER: C. Jones  
 ASSISTANT: K. Hylton  
 OTHER: none  
 EXCAVATOR: RG&E Operator  
 EQUIPMENT: Backhoe: CASE Extended Arm  
 LOCAL UTILITY CLEARANCE: J. Meehan (RG&E)  
 DEPTH TO GROUNDWATER: not encountered  
 TOTAL DEPTH: 11.5 feet  
 NAPL PRESENT: no

## TEST PIT 2

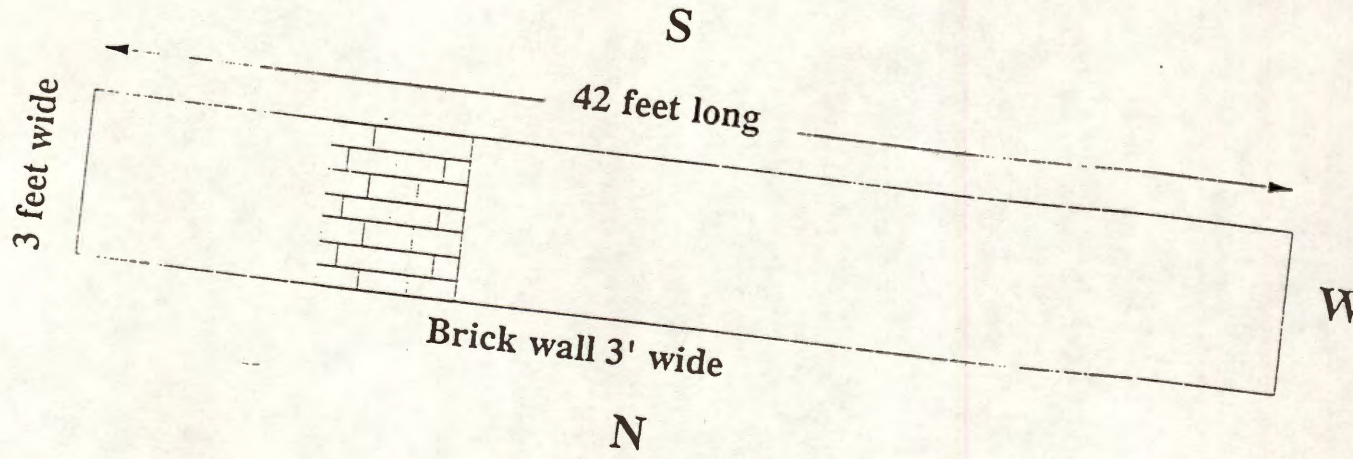

### Test Pit Stratigraphy

0' - 11.5' Fill comprised of ash, clinker, silts, sands, brick, concrete rubble, piping, asphalt, and large cobbles  
 @ 9.8' Top of tar well wall made of brick. Approximately 3' wide.

### Tar Well Test Pit Location

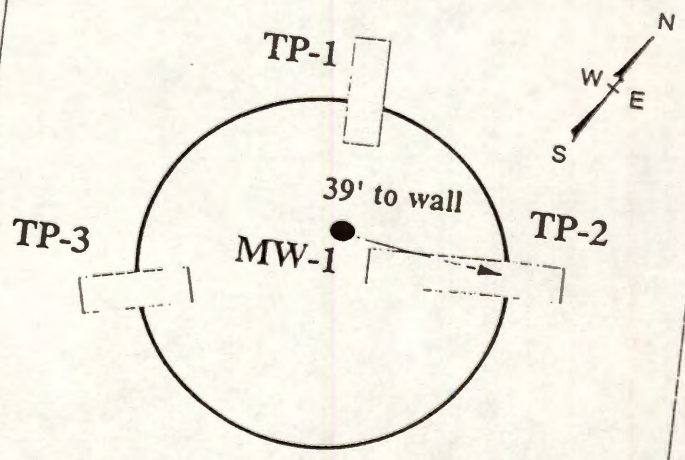



# TEST PIT DESCRIPTION SHEET

PROJECT NUMBER: 103002-51  
 PROJECT: META-EPRI/ RG&E  
 SITE: East Station MGP  
 TEST PIT ID: TP-1  
 LOCATION: North side of circular tar well  
 PURPOSE: To aerially and vertically locate the tar well wall  
 DATE: 11/6/98  
 TIME: 10:00 am  
 WEATHER: overcast, low 50s°F

OBSERVER: C. Jones  
 ASSISTANT: K. Hylton  
 OTHER: none  
 EXCAVATOR: RG&E Operator  
 EQUIPMENT: Backhoe: CASE Extended Arm  
 LOCAL UTILITY CLEARANCE: J. Meehan (RG&E)  
 DEPTH TO GROUNDWATER: not encountered  
 TOTAL DEPTH: 12.0 feet  
 NAPL PRESENT: no

## TEST PIT 1

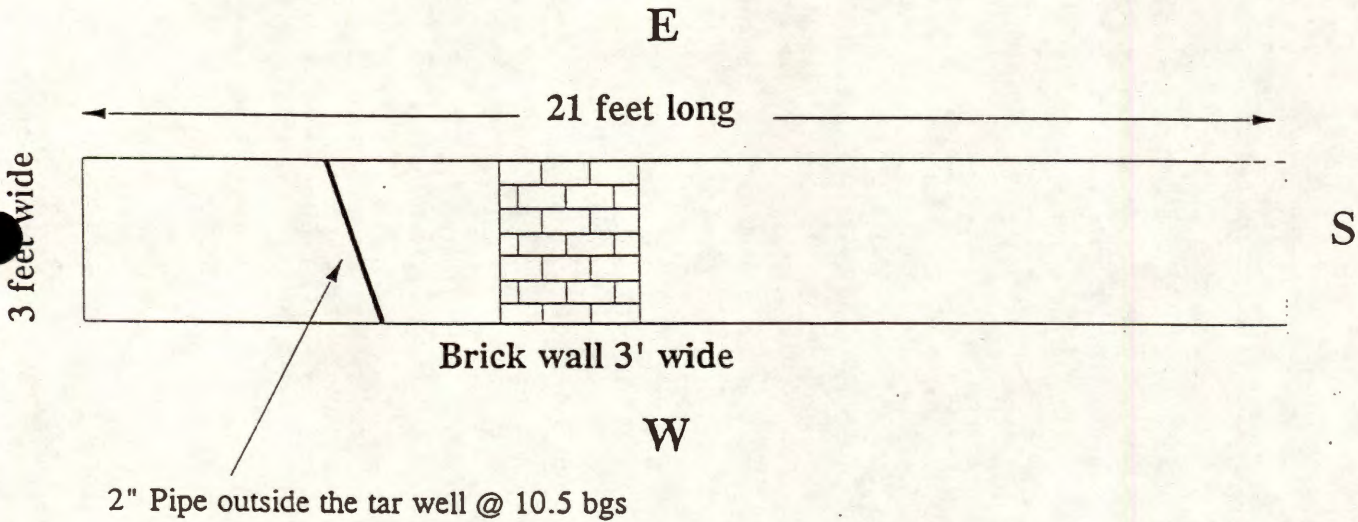

### Test Pit Stratigraphy

- 0' - 12.0' Fill comprised of ash, clinker, silts, sands, brick, concrete rubble, piping, and asphalt
- @ 9.0' Top of tar well wall made of brick. Approximately 3' wide.

### Tar Well Test Pit Location

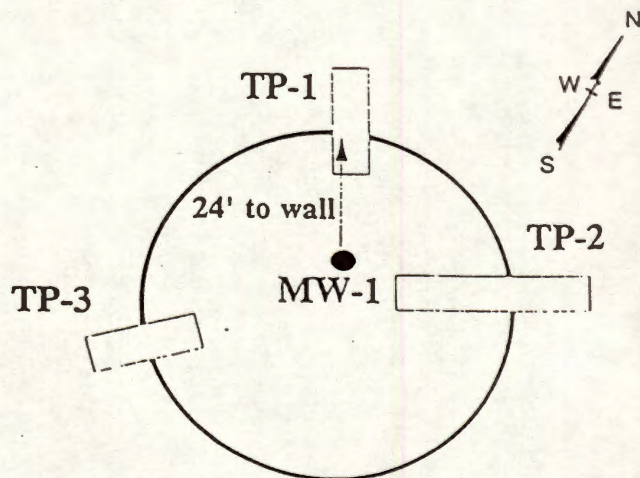

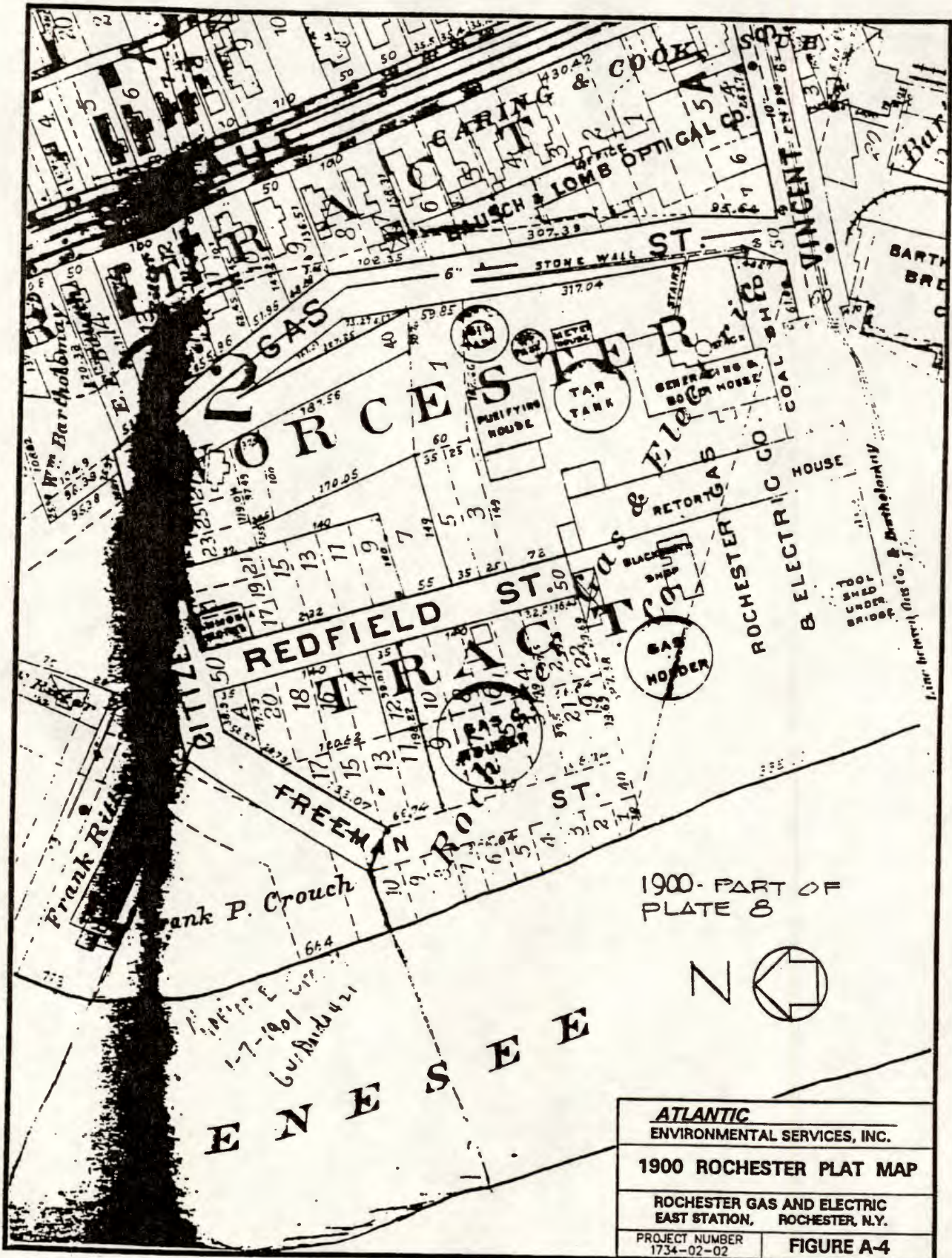

1900 - PART OF  
PLATE 8



E N E S E E

<b>ATLANTIC</b>	
ENVIRONMENTAL SERVICES, INC.	
<b>1900 ROCHESTER PLAT MAP</b>	
ROCHESTER GAS AND ELECTRIC EAST STATION, ROCHESTER, N.Y.	
PROJECT NUMBER 1734-02-02	<b>FIGURE A-4</b>

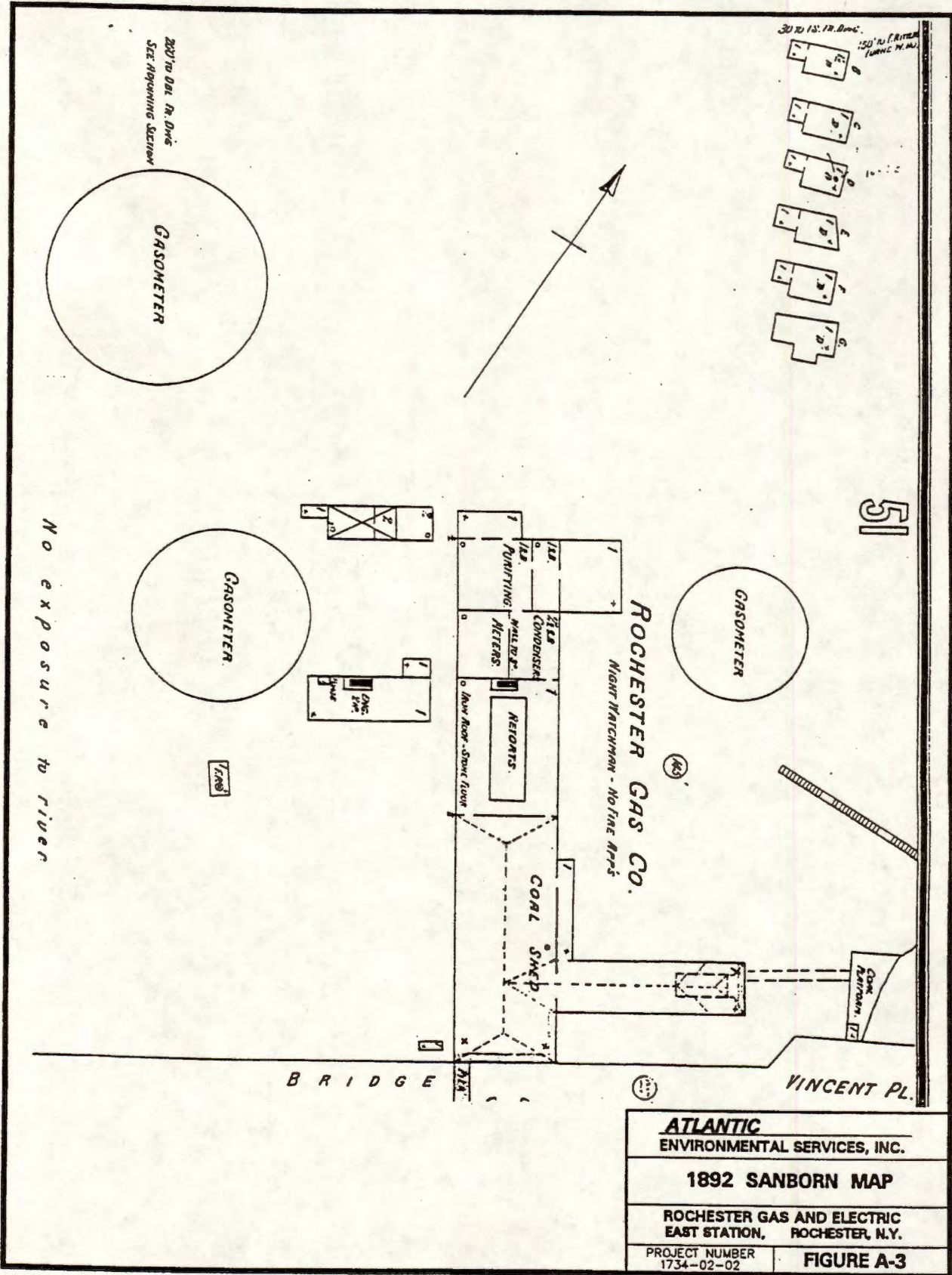

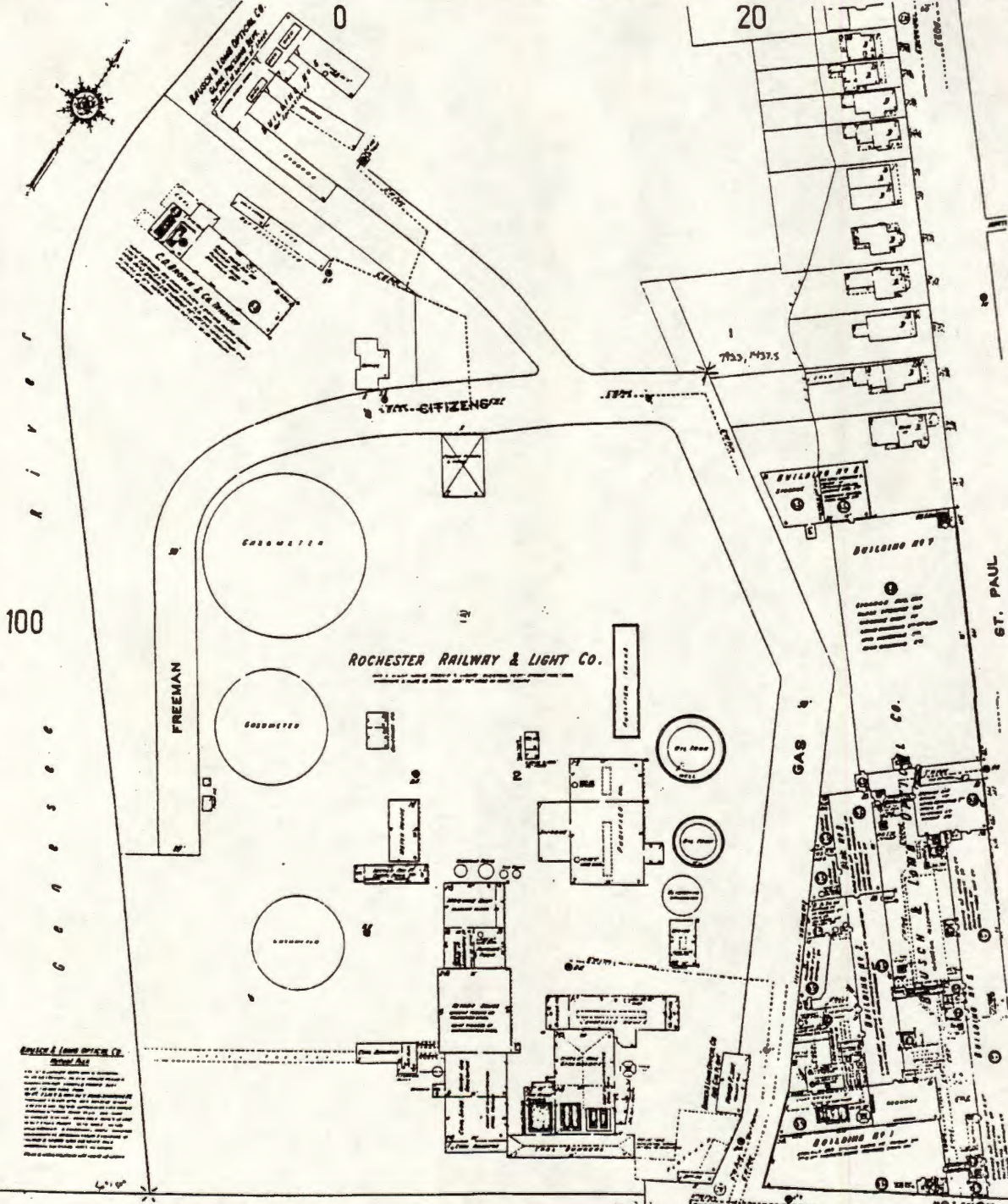
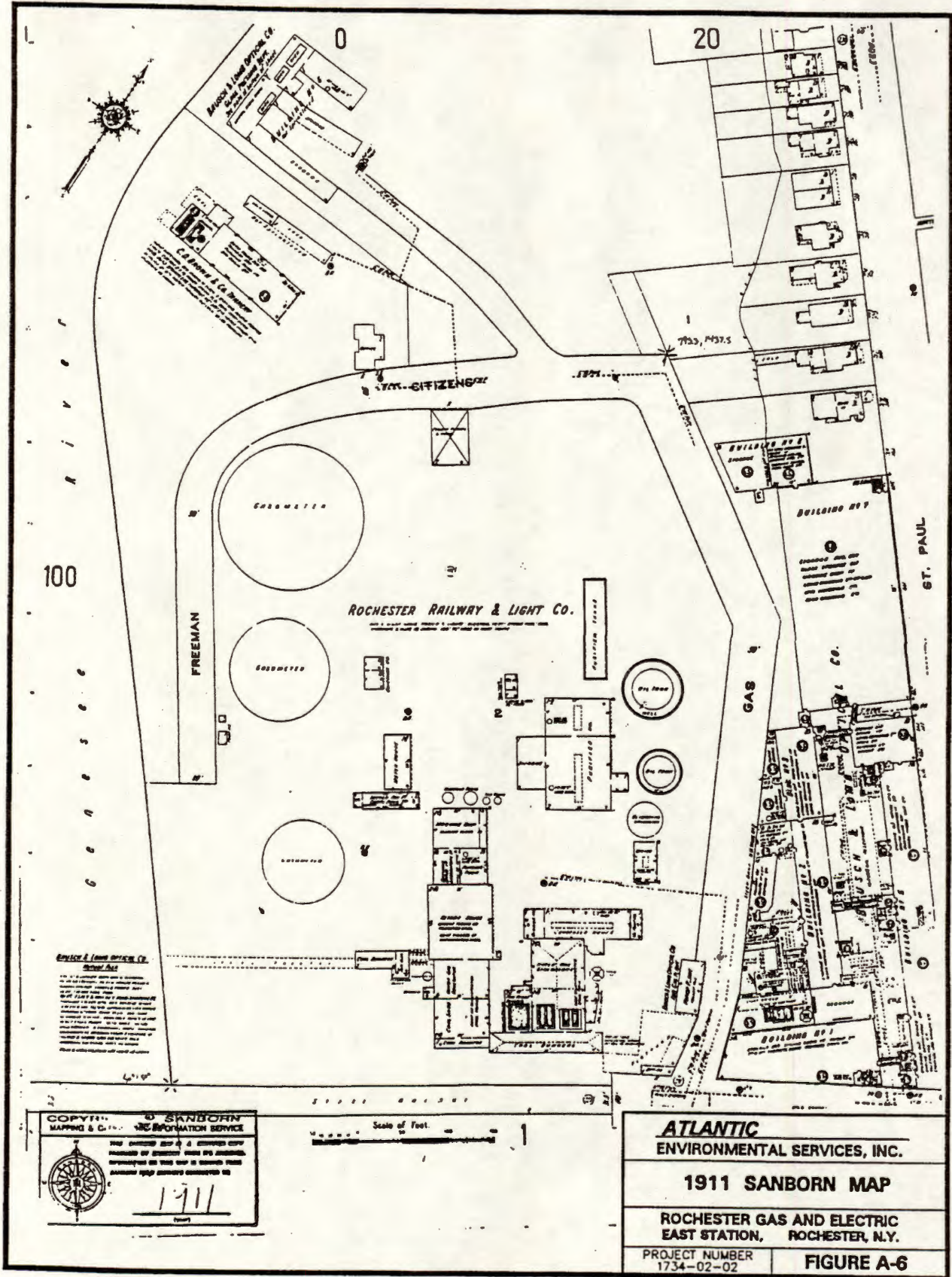

**COPYRIGHT** SANBORN  
 MAPPING & CO. INC. INFORMATION SERVICE

THIS DRAWING IS A SANBORN COPY  
 PREPARED BY ENGINEERS FROM PHOTO  
 REPRODUCTION OF THIS MAP IS PROHIBITED  
 UNLESS SPECIFIC PERMISSION IS OBTAINED

1911

Scale of Feet.

**ATLANTIC ENVIRONMENTAL SERVICES, INC.**

**1911 SANBORN MAP**

**ROCHESTER GAS AND ELECTRIC EAST STATION, ROCHESTER, N.Y.**

PROJECT NUMBER 1734-02-02

**FIGURE A-6**

# ***RG&E***

**ROCHESTER GAS & ELECTRIC CORPORATION**  
89 East Avenue  
Rochester, New York 14649

## **Appendix L**

### **NEW YORK STATE DEPARTMENT OF ENVIRONMENTAL CONSERVATION COMMENTS, RG&E RESPONSES, AND DEC APPROVAL LETTER**

**ASSOCIATED WITH THE  
EAST STATION  
FORMER MANUFACTURED GAS PLANT SITE**

#### **Tar Well Removal Work Plan**

**City of Rochester, Monroe County, New York**  
VCA Index#: B8-0535-98-07  
Site #: V000358-8

October 8, 2004

Prepared By:  
RG&E Environmental Affairs

**New York State Department of Environmental Conservation  
Division of Environmental Remediation**

Remedial Bureau C, 11th Floor  
625 Broadway, Albany, New York 12233-7017  
Phone: (518) 402-9669 • FAX: (518) 402-9679  
Website: www.dec.state.ny.us

received  
8/17/04 - SRM -



August 10, 2004

**Via E-Mail and Regular Mail**

Mr. Steven Mullin, Sr. Environmental Analyst  
Rochester Gas and Electric  
Environmental Affairs  
89 East Avenue  
Rochester, New York 14649-0001

Dear Mr. Mullin:

RE: RG&E MGP Site, East Station Site # V00358-8 Rochester, Monroe County,  
New York, Draft IRM Work Plan Submittal for Former Tar Well Contents  
Removal, prepared by RG&E, dated June 18, 2004.

The New York State Department of Environmental Conservation, ( hereafter "The Department") and the New York State Department of Health (NYSDOH) have made a cursory review and is now providing comments on this Draft Work Plan. The Department also has provided RG&E verbal comments pursuant to our discussions on our conference call on July 1, 2004. Most importantly, the Draft Work Plan is not acceptable as submitted and must be revised to include not only the removal of the contents of the holder, but the total removal and disposal of the holder structure and associated piping, including the surrounding contaminated soils, NAPL and Tar. Accordingly, RG&E must address these comments and submit a revised Draft Work Plan to the Department within 30 days after receipt of this letter.

If you have any questions regarding these comments, please contact me at (518) 402-9665 or by e-mail, at [sfpriore@gw.dec.state.ny.us](mailto:sfpriore@gw.dec.state.ny.us).

Sincerely,

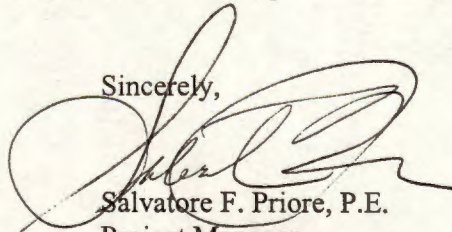

Salvatore F. Priore, P.E.  
Project Manager,  
RG&E MGP Sites  
Remedial Bureau C  
Division of Environmental Remediation

SFP/sfp

cc: C.Bethoney- DOH Troy  
J. Albert-MCDOH

**NYSDEC Comments on East Station of RG&E**  
**Draft IRM Work Plan for Tar Well Contents Removal**  
**Dated 06/18/04**

**Specific Comments:**

- 1) The Title of the Work plan must be revised to “IRM Work Plan for Tar Well removal and disposal and excavation and disposal of Impacted soils, NAPL and Tar residues.”
- 2) The Final Work plans and submittals must be stamped by a New York State Professional Engineer, licensed to practice engineering in the State of New York.
- 3) Section 1.2- The Sanborn Maps should be included with this workplan along with applicable cross-sections of the holder and surrounding area.
- 4) Section 1.3- The nature and final disposition of the wastes must conform to all applicable testing to determine its' classification as Hazardous or Non-hazardous or conditionally exempt under current State and Federal regulations.
- 5) Section 1.4- RG&E must state that these reports were commissioned for RG&E only and not formally submitted to the Department for approval, and were only submitted after the execution of the Voluntary Agreement for informational purposes and have not been reviewed nor approved by the Department as part of the site record. The Focused Feasibility Study shall not be referenced as an approved or sanctioned document by the Department that can be used by RG&E to limit remedial options at the site.
- 6) Section 2.0- This section needs to be rewritten. The project objective is to remove the entire holder and the surrounding contaminated soils, NAPL and Tar. This IRM is independent of the Site-Wide remedy, but is a part of a phase approach to remediate the site.
- 7) Section 2.0- The Work plan schedule must be in a separate section and should include dates and sequenced tasks.
- 8) Sections 4.0.1.3 and 4.0.1.4- Explain the PAH number range as the defining Criteria of these wastes.
- 9) Section 4.0.2- Pre-remediation Sampling and Analysis – It is our understanding that this sampling and analysis will only be used for this IRM, to segregate soil into two categories for possible re- use and/or disposal. However, we do not concur with the definition of soil listed in the IRM Workplan as potential sub-surface fill. Although the excavated soil may have no or may have minimal visible evidence of staining, it does not necessarily indicate that contaminant levels are below any IRM goal of total polycyclic aromatic hydrocarbon (PAH) level. The “visual” method of compound detection is not reliable and is very subjective and cannot be used as the final confirmatory analysis. In addition, the proposed sub-surface fill goal of < 1000 ppm for total PAHs is not acceptable to the Department and NYSDOH at this time due to the possibility that elevated levels of carcinogenic PAHs that may remain. The total PAH IRM goal should be at <500ppm, and an analysis of individual carcinogenic PAHs reported. These data from the IRM will be utilized in determining the final remedial goals during the site-wide remedial design. Please be aware that for any remedial goal that is chosen, it is site specific and may contain land use controls and environmental easements on the property, should significant post-remediation contamination remains on-site. Further evaluation and revision of this proposed sub-surface backfill remedial objective will be discussed in the Remedial Action Work plan.

10) Section 4.0.3 Cleanup Objectives, page 7- The overall objective is the removal of the holder and foundation as well as removing contaminated material from the surrounding area. Confirmation samples must be taken at the limits of excavation.

11) Section 4.0.4.1, Subsurface Fill, page 7- Once sampled analyzed and reported, including individual cPAH values to the DEC/DOH, a determination will be made by DEC/DOH whether the excavated soils may be utilized for subsurface fill or require disposal off-site.

12) Section 4.0.5, Confirmation Sampling Requirements, page 11- Coal Tar soil that is well beyond the agreed scope of the IRM will be delineated, surveyed and appropriately covered for future remediation.

13) Section 4.3, Work Activities, page 13 – Please include how water used during the “power washing” of tar well side walls will be disposed of. Also, change title of IRM Work Plan to state removal of holder and related foundations. Delete referenced language from start of the 3<sup>rd</sup> paragraph to the end of the paragraph and rewrite to incorporate the removal of the structure and foundations.

14) Section 4.4, Groundwater, Stormwater and Wastewater Management, page 14- The postponement of any of the excavation activities due to high water table will be subject to the Department approval. RG&E shall employ and secure sufficient dewatering frac tanks or Modu-Tanks to provide for adequate capacity. RG&E must also provide for the ability for temporary sheeting around the structure to provide and control groundwater in order to dewater the excavation. RG&E must include a more extensive site water management plan.

15) Section 4.7, Contingency Plan, page 14- Change Title of Work Plan

16) Section 4.8, Site Restoration – Rewrite the first bullet to state that all excavated soils must be analyzed and approved by the Department before be used to backfill the excavation. Also, RG&E must specify where they will obtain the stated “recycled crushed concrete”. Any material must be sampled and analyzed and approved prior to use on-site.

17) Section 5.1, Overview, 2<sup>nd</sup> paragraph, page 17- Change Title of Workplan.

18) Section 5.2.3, Speciated Real-Time Air Monitoring, Page 19- Replace two site perimeter monitoring stations, with “a minimum of two”.

19) Section 5.2.4, Odor Monitoring Plan- There is concurrence that if complaints are received then the Vapor Emission Response Plan should be implemented. However, significant odors may be generated and on-site personnel may not be able to detect them due to olfactory fatigue. RG&E should implement and use a non-exclusion zone on-site personnel to monitor the odors. Also, RG&E must explain how they would determine and take action if “odors become non-discernable”. The NYSDOH must review the Site Health and Safety Plan and Community Air Monitoring Plan prior to any on-site work occurring.

20) Section 5.2.5, Real-Time Air Monitoring- TSP, page 20- The 2<sup>nd</sup> paragraph, last sentence requires revision to include whether the notification is in accordance with TAGM 4031.

21) Section 5.2.7, Vapor Emission Response Plan, page 21- Change title of Workplan.

22) Section 6.0, Sampling and Analysis Plan, page 23- Change Title of Workplan.

22) Section 6.1, QA/QC, page 23- Change Title of Workplan.

23) Section 6.2.3.1, 6.2.3.2, 6.2.3.3, Pre-remediation In Situ Sampling Rationale, page 25&26- Change Title of Workplan.



24) Section 6.2.4.2, Laboratory Analytical Protocols, page 26- Change Title of Workplan.

25) Section 7.0, Health and Safety Plan, page 28- The project specific HASP should be reviewed by RG&E prior to submission to the Department and NYSDOH to ensure it meets the minimum requirements.

26) Figures - Add cross-sections of Holder and Foundations as well as surrounding geologic conditions. Include historic or plans from holder installation, if available. Also include a cross section and plan view of IRM excavation scenarios.

27) Pre-Remediation In-Situ Sampling & Analysis Workplan- Change Title of Workplan throughout.

- Section 1.0, Introduction, page 1- Revise language to include holder and foundation excavation.
- Section 2.0, Sampling Protocol, page 2- The number of samples, (8 min) must be increased to 15-20-samples. Four (4) Test pits should be a minimum. The sample cores should be extended to the bottom, plus 2-3 ft. below the known foundation elevation of the holder. The Macro-core may not be suitable for this soil matrix. Conventional borings should be utilized. SVOC analysis shall be conducted from each boring by utilizing a representative composite of each of the intervals that comprises the specific boring or test pit. Characterization of entire area by compositing by borings alone is not acceptable. If test pits are utilized, then flexibility of sampling and characterization can be discussed further.
- Section 3.0, Waste Characterization, page 3- See Comments and revise per Section 2.0.
- Table 4, Carcinogenic cPAHs may be considered separately from the 500 ppm goal for total PAHs.
- Table 6, Sampling Breakdown - Revise sampling locations and number of samples per preceding comments.

28) Citizen Participation Plan- Change Title of IRM Workplan throughout.

- Section 3.0, Previous investigations, IRMs, Final Engineering Reports, page 2- This section shall be deleted. Reference only approved documents that were reviewed and approved by the Department.
- Section 6.0, Document Repository, page 3 and Section 8.0, page 4- Change 9665 to 9669 to be the main contact number. I don't believe the 800 number is still in service.

29) Construction Quality Assurance Plan- Change Title of IRM Workplan throughout.

30) Quality Assurance Project Plan (QAPP)- Change Title of IRM Workplan throughout.

- Section 7.0, Data Reduction Validation and Reporting, page 12- All data shall be stored and copied in pdf format on CD disk when transmitted to the Department with the Summary Report.

31) Transportation of Solid and/or Liquid Materials- Change Title of IRM Workplan throughout.

32) Contingency Plan- Change Title of IRM Workplan throughout.



690 W. Fremont Avenue, Sunnyvale, CA 94087  
Phone (408) 720-0474 Fax (408) 773-0474 Cell/VM (408) 892-3233

October 2,, 2004

Mr. Salvatore F. Priore, P.E.  
Project Manager  
New York State Department of Environmental Conservation  
Division of Environmental Remediation  
Remedial Bureau C, 11th Floor  
625 Broadway, Albany, New York 12233-7017

RE: RG&E MGP Site, East Station Site # V00358-8 Rochester, Monroe County, New York  
Draft IRM Work Plan Submittal for Former Tar Well Contents Removal, prepared by  
RG&E, dated June 18, 2004.

Dear Mr. Priore:

On behalf of our client Rochester Gas and Electric, Ish Inc. has prepared the following responses to the NYSDEC comments dated August 10, 2004 (received via email on August 12, 2004 and U.S. mail on August 17, 2004) on the Draft Work Plan for Tar Well Contents Removal at the East Station former MGP site. For clarity, we have first presented the DEC comment in the order contained in the DEC letter and then have written the RG&E response to that comment.

NYSDEC comment 1: The Title of the Work plan must be revised to "IRM Work Plan for Tar Well removal and disposal and excavation and disposal of impacted soils, NAPL and Tar residues".

RG&E Response to Comment 1: The title of the work plan has been revised to "IRM Work Plan for Removal of Tar Well at the East Station Former MGP Site".

NYSDEC Comment 2: The Final Work plans and submittals must be stamped by a New York State Professional Engineer, licensed to practice engineering in the State of New York.

RG&E Response to Comment 2: The final work plan and submittals associated with the work plan that require stamping by a New York State Professional Engineer will be stamped by Mr. Joseph M Simone, who is a professional engineer, licensed to practice engineering in the State of New York.

NYSDEC Comment 3: Section 1.2- The Sanborn Maps should be included with this work plan along with applicable cross-sections of the holder and surrounding area.

RG&E Response to Comment 3: Selected Sanborn maps will be included in the final work plan as well as cross-sections of the tar well that have been previously prepared and submitted to the Department in other documents. Refer to Section 1.5 in the revised work plan for the requested information.

NYSDEC Comment 4: Section 1.3- The nature and final disposition of the wastes must conform to all applicable testing to determine its classification as Hazardous or Non-hazardous or conditionally exempt under current State and Federal regulations.

RG&E Response to Comment 4: The revised work plan will be expanded to clarify that excavated materials will be tested by applicable test methods to determine their classification as hazardous or non-hazardous or conditionally exempt wastes under the state and federal regulations. The final treatment and disposal or reuse will conform to the determined classification.

NYSDEC Comment 5: Section 1.4- RG&E must state that these reports were commissioned for RG&E only and not formally submitted to the Department for approval, and were only submitted after the execution of the Voluntary Agreement for informational purposes and have not been reviewed nor approved by the Department as part of the site record. The Focused Feasibility Study shall not be referenced as an approved or sanctioned document by the Department that can be used by RG&E to limit remedial options at the site.

RG&E Response to Comment 5: RG&E will revise the wordings to explicitly state that the previously completed site investigations reports commissioned by RG&E were neither formally reviewed nor officially approved by the Department. Furthermore the RG&E commissioned FFS was neither approved nor sanctioned by the Department and is not intended to limit consideration of potentially applicable remedial options for the site.

NYSDEC Comment 6: Section 2.0- This section needs to be rewritten. The project objective is to remove the entire holder and the surrounding contaminated soils, NAPL and Tar. This IRM is independent of the Site-Wide remedy, but is a part of a phased approach to remediate the site.

RG&E Response to Comment 6: The final work plan will state that "the overall objective of the proposed IRM is to eliminate coal tar NAPL from the tar well area at the East Station former MGP site." This objective will be met by excavating, removing, and disposing off-site the former gasholder/tar well inclusive of its contents, foundation, connective piping (if present), and DNAPL containing material immediately adjacent to the holder/tar well structure to a distance not to exceed 20 feet outside the structure. This approach is consistent with discussions during a conference call between representatives of RG&E and the Department on July 1, 2004. Media impacted with contaminants of concern (COC) beyond the stated distance will be evaluated for removal in the field at the time of the IRM activities, and if not addressed at that time will be

addressed as part of a site wide remedy or other remedial action.

NYSDEC Comment 7: Section 2.0- The Work plan schedule must be in a separate section and should include dates and sequenced tasks.

RG&E Response to Comment 7: RG&E will provide a separate schedule for the IRM activities that will list the tasks in sequence and the target dates for their implementation.

NYSDEC Comment 8: Sections 4.0.1.3 and 4.0.1.4- Explain the PAH number range as the defining Criteria of these wastes.

RG&E Response to Comment 8: As indicated in response to comment 4, RG&E will collect and analyze soil samples using applicable test methods to classify the excavated materials as hazardous, non-hazardous or conditionally exempt waste. The excavated material that falls below the DEC suggested level of less than 500 mg/Kg total PAH may be reused to backfill the excavated area. Other materials will be treated and/or disposed conforming to the determined classification.

NYSDEC Comment 9: Section 4.0.2- Pre-remediation Sampling and Analysis - It is our understanding that this sampling and analysis will only be used for this IRM, to segregate soil into two categories for possible re- use and/or disposal. However, we do not concur with the definition of soil listed in the IRM Work plan as potential sub-surface fill. Although the excavated soil may have no or may have minimal visible evidence of staining, it does not necessarily indicate that contaminant levels are below any IRM goal of total polycyclic aromatic hydrocarbon (PAH) level. The "visual" method of compound detection is not reliable and is very subjective and cannot be used as the final confirmatory analysis. In addition, the proposed sub-surface fill goal of < 1000 ppm for total PAHs is not acceptable to the Department and NYSDOH at this time due to the possibility that elevated levels of carcinogenic PAHs that may remain. The total PAH IRM goal should be at <500ppm, and an analysis of individual carcinogenic PAHs reported. These data from the IRM will be utilized in determining the final remedial goals during the site-wide remedial design. Please be aware that for any remedial goal that is chosen, it is site specific and may contain land use controls and environmental easements on the property, should significant post-remediation contamination remains on-site. Further evaluation and revision of this proposed sub-surface backfill remedial objective will be discussed in the Remedial Action Work plan.

RG&E Response to Comment 9: RG&E accepts the NYSDEC alternative limit of less than 500 mg/Kg of PAHs for this project for the reuse of the excavated soil. The work plan will be revised to reflect this.

NYSDEC Comment 10 Section 4.0.3 Cleanup Objectives, page 7- The overall objective is the removal of the holder and foundation as well as removing contaminated material from the surrounding area. Confirmation samples must be taken at the limits of the excavation.

RG&E Response to Comment 10: Please see the response to comment number 6 describing the wording for the revised objective for the IRM. RG&E will collect and analyze appropriate number of confirmation samples at the limits of excavation (i.e. sidewall sampling).

NYSDEC Comment 11: Section 4.0.4.1, Subsurface Fill, page 7- Once sampled, analyzed and reported, including individual cPAH values to the DEC/DOH, a determination will be made by DEC/DOH whether the excavated soils may be utilized for subsurface fill or require disposal off-site.

RG&E Response to Comment 11: The pre-characterization sampling and analysis data are expected to provide a reliable basis for the classification of the excavated material for potential reuse or for treatment and disposal. RG&E will use the DEC recommended level of less than 500 mg/Kg total PAHs value for reuse as backfill.. The analytical results for the 17 PAHs generated from the soil samples collected from the stockpiled soil that is segregated for reuse will be tabulated as individual PAH (both non-carcinogenic and carcinogenic), total PAH (PAH<sub>T</sub>), and as total carcinogenic PAH (cPAH<sub>T</sub>). These tabulated results of soil samples will be provided for review and determination by DEC/DOH prior to reuse of the material for backfilling of the excavated area.

NYSDEC Comment 12: Section 4.0.5, Confirmation Sampling Requirements, page 11- Coal Tar soil that is well beyond the agreed scope of the IRM will be delineated, surveyed and appropriately covered for future remediation.

RG&E Response to Comment 12: This proposed IRM focuses on the removal of the gas holder/tar well so that DNAPL/coal tar material in this structure is eliminated from the East Station site. Therefore, the extent of excavation has been limited to about 20 feet outside the tar well/ holder foundation area. Subsequent RG&E actions will be devoted to developing and undertaking, in a phased manner, additional investigation and remedial actions as approved by the NYSDEC. Confirmatory samples will be taken and appropriately measured and documented and the footprint of the excavations and soil removal areas will be surveyed.

NYSDEC Comment 13 Section 4.3, Work Activities, page 13 - Please include how water used during the "power washing" of tar well side walls will be disposed of. Also, change title of IRM Work Plan to state removal of holder and related foundations. Delete referenced language from start of the 3<sup>rd</sup> paragraph to the end of the paragraph and rewrite to incorporate the removal of the structure and foundations.

RG&E Response to Comment 13: Since the revised IRM work plan will include removal of the holder/tar well foundations, "power washing" the side walls is not anticipated. However, if the walls should require "power washing" to accommodate disposal requirements, the water that is generated will be collected and appropriately managed for disposal. As indicated in response to comment 1, the IRM work plan title has been revised.

NYSDEC Comment 14: Section 4.4, Groundwater, Storm water and Wastewater Management, page 14- The postponement of any of the excavation activities due to high water table will be subject to the Department approval. RG&E shall employ and secure sufficient dewatering frac tanks or Modu-Tanks to provide for adequate capacity. RG&E must also provide for the ability for temporary sheeting around the structure to provide and control groundwater in order to dewater the excavation. RG&E must include a more extensive site water management plan.

RG&E Response to Comment 14: RG&E intends to carry out the IRM with the oversight and concurrence of the Department. Based on information known about the site conditions at this time, significant groundwater or waste water is not expected to be generated requiring treatment and disposal. RG&E, however, will be prepared to store waste water in frac tanks for offsite disposal or may employ an onsite water treatment/pre-treatment system for discharge to the nearby river or Monroe County Sewer system. Further details will be developed during the final preparations of the IRM implementation plans. RG&E does not see a need for temporary sheeting around the structure, particularly in light of the fact that excavation activities will terminate at the bedrock surface at about 12 to 15 feet depth from the excavation surface.

NYSDEC Comment 15: Section 4.7, Contingency Plan, page 14- Change Title of Work Plan

RG&E Response to Comment 15: The title of the work plan has been changed as requested.

NYSDEC Comment 16: Section 4.8, Site Restoration - Rewrite the first bullet to state that all excavated soils must be analyzed and approved by the Department before be used to backfill the excavation. Also, RG&E must specify where they will obtain the stated "recycled crushed concrete". Any material must be sampled and analyzed and approved prior to use on-site.

RG&E Response to Comment 16: The bullet will be revised to state that RG&E will collect and analyze samples from the excavated soils and after the prompt approval by the Department will reuse the soils containing less than 500 mg/Kg of PAHs for backfill. The "crushed concrete" to be used as backfill is currently on-site. The material is the remnants of the aboveground portions of a building that was demolished in 2000 on RG&E owned property located at 84 Andrews Street, Rochester. RG&E proposes to collect three composite samples from the recycled crushed concrete deposit on the East Station site and analyze them for VOC and SVOC as requested by the Department. The results will document the unimpacted nature of the recycled crushed concrete before it is used for backfilling of the excavated area.

NYSDEC Comment 17: Section 5.1, Overview, 2<sup>nd</sup> paragraph, page 17- Change Title of Work plan.

RG&E Response to Comment 17: Title of the work plan has been changed as requested.

NYSDEC Comment 18: Section 5.2.3, Speciated Real-Time Air Monitoring, Page 19- Replace two site perimeter monitoring stations, with "a minimum of two".

RG&E Response to Comment 18: The work plan has been revised to state “a minimum of two site perimeter.....”

NYSDEC Comment 19: Section 5.2.4, Odor Monitoring Plan- There is concurrence that if complaints are received then the Vapor Emission Response Plan should be implemented. However, significant odors may be generated and on-site personnel may not be able to detect them due to olfactory fatigue. RG&E should implement and use non-exclusion zone on-site personnel to monitor the odors. Also, RG&E must explain how they would determine and take action if "odors become non-discernable". The NYSDOH must review the Site Health and Safety Plan and Community Air Monitoring Plan prior to any on-site work occurring.

RG&E Response to Comment 19: As suggested by the Department, RG&E will use on-site personnel from non-exclusion zone to monitor odors and determine if the odors are discernable or non-discernable. This determination will be subject to concurrence by the on-site NYSDEC representative. RG&E plans to submit for review by the NYSDOH, the site specific Health and Safety Plan. The Community Air Monitoring Plan is included in the IRM work plan as Section 5.2

NYSDEC Comment 20: Section 5.2.5, Real-Time Air Monitoring- TSP, page 20- The 2<sup>nd</sup> paragraph, last sentence requires revision to include whether the notification is in accordance with TAGM 4031.

RG&E Response to Comment 20: The IRM work plan has been revised to state “ within five working days in accordance with the NYSDEC TAGM 4031”

NYSDEC Comment 21: Section 5.2.7, Vapor Emission Response Plan, page 21- Change title of Work plan.

RG&E Response to Comment 21: Title of the work plan has been changed as requested.

NYSDEC Comment 22: Section 6.0, Sampling and Analysis Plan, page 23- Change Title of Work plan.

RG&E Response to Comment 22: Title of the work plan has been changed as requested.

NYSDEC Comment 22: Section 6.1, QA/QC, page 23- Change Title of Work plan.

RG&E Response to Comment 22: Title of the work plan has been changed as requested.

NYSDEC Comment 23: Section 6.2.3.1, 6.2.3.2, 6.2.3.3, Pre-remediation in Situ Sampling Rationale, page 25&26- Change Title of Work plan

RG&E Response to Comment 23: Title of the work plan has been changed as requested.

NYSDEC Comment 24: Section 6.2.4.2, Laboratory Analytical Protocols, page 26- Change Title of Work plan.

RG&E Response to Comment 24: Title of the work plan has been changed as requested.

NYSDEC Comment 25: Section 7.0, Health and Safety Plan, page 28- The project specific HASP should be reviewed by RG&E prior to submission to the Department and NYSDOH to ensure it meets the minimum requirements.

RG&E Response to Comment 25: RG&E will review and revise, if necessary, the site specific HASP prior to its submission for review to the Department and the NYSDOH to ensure that it meets the minimum requirements.

NYSDEC Comment 26: Figures - Add cross-sections of Holder and Foundations as well as surrounding geologic conditions. Include historic or plans from holder installation, if available. Also include a cross section and plan view of IRM excavation scenarios.

RG&E Response to Comment 26: RG&E will include in the revised IRM work plan the requested figures and cross-sections to the extent possible.

NYSDEC Comment 27: Pre-Remediation In-Situ Sampling & Analysis Work plan- Change Title of Work plan throughout.

- Section 1.0, Introduction, page 1- Revise language to include holder and foundation excavation.
- Section 2.0, Sampling Protocol, page 2- The number of samples, (8 min) must be increased to 15-20 samples. Four (4) Test pits should be a minimum. The sample cores should be extended to the bottom, plus 2-3 ft. below the known foundation elevation of the holder. The Macro-core may not be suitable for this soil matrix. Conventional borings should be utilized. SVOC analysis shall be conducted from each boring by utilizing a representative composite of each of the intervals that comprises the specific boring or test pit. Characterization of entire area by compositing by borings alone is not acceptable. If test pits are utilized, then flexibility of sampling and characterization can be discussed further.
- Section 3.0, Waste Characterization, page 3- See Comments and revise per Section 2.0.
- Table 4, Carcinogenic cPAHs may be considered separately from the 500 ppm goal for total PAHs.
- Table 6, Sampling Breakdown - Revise sampling locations and number of samples per preceding comments.

RG&E Response to Comment 27: RG&E has revised the sampling and analysis plan extensively and we believe it incorporates satisfactory responses to the DEC comments and provides sufficient



information to characterize the soil for potential reuse and/or disposal. As indicated in the revised Sampling and Analysis work plan, RG&E plans to use the Geoprobe macrocore sampling method for the collection of soil samples for characterization of the subsurface material in the target IRM area. However, the driller will be equipped with the capability to switch over to hollow-stem auger drilling method with split spoon sampling if the Geoprobe macrocore sampling method is found not to be performing well due to the nature of the subsurface material observed during the field work. This revised sampling and analysis plan also shows that two test pits will be excavated and tests will be conducted to obtain data for water management planning. The soil samples collected will be analyzed for the various chemical parameters as indicated in the sampling and analysis plan. The analytical results for the 17 PAHs will be tabulated as individual PAH (both non-carcinogenic and carcinogenic), total PAH (PAH<sub>T</sub>), and as total carcinogenic PAH (cPAH<sub>T</sub>).

NYSDEC Comment 28: Citizen Participation Plan- Change Title of IRM Work plan throughout.

- Section 3.0, Previous investigations, IRMs, Final Engineering Reports, page 2- This section shall be deleted. Reference only approved documents that were reviewed and approved by the Department.
- Section 6.0, Document Repository, page 3 and Section 8.0; page 4- Change 9665 to 9669 to be the main contact number. I don' believe the 800 number is still in service

RG&E Response to Comment 28: RG&E has changed the title as requested and will make the other changes in revising the document as suggested by the Department.

NYSDEC Comment 29: Construction Quality Assurance Plan- Change Title of IRM Work plan throughout.

RG&E Response to Comment 29: The title has been revised throughout as requested by the Department.

NYSDEC Comment 30: Quality Assurance Project Plan (QAPP) - Change Title of IRM Work plan throughout.

- Section 7.0, Data Reduction Validation and Reporting, page 12- All data shall be stored and copied in pdf format on CD disk when transmitted to the Department with the Summary Report.

RG&E Response to Comment 30: The title has been revised throughout as requested by the Department. RG&E will provide copy of the data in pdf format on a Disk to the Department with the project summary report.

NYSDEC Comment 31: Transportation of Solid and/or Liquid Materials- Change Title of IRM Work plan throughout.

Mr. Priore, P.E.  
October 2, 2004  
Page 9 of 9

RG&E Response to Comment 31: The title has been revised throughout as requested by the Department.

NYSDEC Comment 32: Contingency Plan- Change Title of IRM Work plan throughout.

RG&E Response to Comment 32: The title has been revised throughout as requested by the Department.

Upon receipt of DEC concurrence with our response to DEC comments, we will finalize the work plan and submit the final version for your final approval. RG&E requests that the Department approve our plans to implement the Pre-remediation In-Situ Sampling & Analysis work plan contained in the Appendix A of the IRM work Plan by October 15<sup>th</sup>, 2004, so that we can conduct the field work during the week of October 18, 2004. If you have any questions or further comments, please do not hesitate to contact Steve Mullin, the RG&E Project Manager, at 585-771-4556 or me on my mobile phone at 408-892-3233.

We look forward to receiving DEC/DOH concurrence as soon as possible. .

Sincerely,

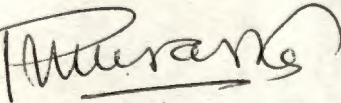

Ishwar P. Murarka, Ph.D.  
Chief Scientist.  
Ish Inc.

CC: Steve Mullin, RG&E  
Charlotte Bethoney, NYSDOH Troy  
Joseph Simone, P.E., Manager, Site Investigation and Remediation for NYSEG and RG&E