

Norlite, LLC

# OUTFALL 006 RECONFIGURATION REPORT

SPDES Permit No. NY0004880

November 2018

---

*This document is intended only for the use of the individual or entity for which it was prepared and may contain information that is privileged, confidential and exempt from disclosure under applicable law. Any dissemination, distribution or copying of this document is strictly prohibited.*

## CONTENTS

Acronyms and Abbreviations.....	ii
Background .....	1
CORMIX Modeling.....	2
Relevant Mixing Zone Guidance Documents .....	2
Previously Evaluated Single Port Outfall Configuration.....	2
Proposed Multiport Outfall Configuration.....	6
Proposed Design .....	11
Constructability.....	12
Detailed Design Phase .....	13
Permitting and Approvals.....	13
Force Main Hydraulic Analysis .....	14
Bathymetric Survey.....	14
Maintenance Requirements .....	14
Reliability.....	14
Outfall Reconfiguration Alternative.....	15
Proposed Design and Construction Schedule.....	15

## FIGURES

Figure 1. Proposed Force Main Extension.....	16
Figure 2. Outfall Port Spacing .....	17
Figure 3. Outfall 006 Detail.....	18
Figure 4. Doghouse Manhole Detail.....	19
Figure 5. Entrance and Exit Manhole Details.....	20

## ACRONYMS AND ABBREVIATIONS

7Q10 Flow	Lowest average discharge over a 7-day flow period in a 10-year time span
CORMIX	Cornell Mixing Expert System
NYS DEC	New York State Department of Environmental Conservation
SEQR	State Environmental Quality Review
SHPO	State Historic Preservation Office
SPDES	State Pollutant Discharge Elimination System
TDS	Total Dissolved Solids
TOGS	Technical Operational Guidance Series
US EPA	United States Environmental Protection Agency
WWTP	Wastewater Treatment Plant

## BACKGROUND

Norlite, LLC (Norlite), a subsidiary of Tradebe Environmental Services, LLC (Tradebe) operates a lightweight aggregate production facility in Cohoes, NY. The facility holds a State Pollutant Discharge Elimination System (SPDES) permit (SPDES Permit No. NY0004880) issued by the New York State Department of Environmental Conservation (NYS DEC), under which scrubber blowdown, boiler blowdown, trunnion non-contact cooling water, and plant water are treated by an on-site wastewater treatment plant (WWTP) and discharged via Outfall 006. Existing Outfall 006 currently discharges via a 4-inch force main to the City of Cohoes' storm sewer system and ultimately to the Mohawk River (River). The City's storm sewer is 8-inches in diameter from Saratoga Street (near the intersection of Bridge Street) through the Mohawk Paper property before it connects to a 36-inch storm pipe that conveys Norlite's treated effluent, combined with City stormwater, to the west bank of the River.

The previous SPDES Permit included a 100:1 dilution factor for Norlite's Outfall 006 water quality based effluent limits. However, during the permit renewal process, NYS DEC observations and subsequent Cornell Mixing Expert System (CORMIX) modeling indicated that mixing at the current River discharge point is poor. Accordingly, the revised SPDES Permit (effective November 1, 2017) reflected no dilution, with Schedule of Compliance provisions allowing Norlite to propose modifications to the existing outfall that would re-establish an appropriate mixing zone.

Accordingly, Norlite is proposing to re-route and reconfigure the existing outfall to re-establish a mixing zone for dilution in the River. The project will include separating the Outfall 006 effluent from the City of Cohoes stormwater and extending the existing force main from the Norlite facility to the River. A portion of the proposed force main extension will pass through, or around, Mohawk Paper property before entering and extending the force main through the City of Cohoes' existing 36-inch storm sewer pipe. In the event that it is discovered during the detailed design that there is insufficient capacity in the 36-inch storm sewer pipe to convey existing stormwater flows while accommodating the 4-inch Norlite facility force main, the force main will instead be installed in the City of Cohoes storm sewer right of way, outside of, and generally parallel to, the existing pipe.

The River in the area of the existing outfall is not part of the navigable channel. The water surface level in this location is influenced by the Troy Dam and is therefore not expected to fall below Elevation 14.0. Therefore, it is anticipated that a minimum water depth of 5 feet is conservatively expected to be available for establishing a mixing zone. However, the shore line was observed to be relatively shallow and therefore it is anticipated that this water of an appropriate depth will be at least 50 to 100 feet from the shoreline at the 7Q10 flow (the lowest average discharge over a 7-day flow period in a 10-year time span).

At Norlite's request, Arcadis has developed a preliminary outfall design to re-establish a reasonably-sized mixing zone. Arcadis has also developed a preliminary design for the Outfall 006 re-routing and reconfiguration including analyses of constructability, maintenance requirements, and reliability. This Outfall 006 Reconfiguration Report (Report) is being provided to summarize our findings so that Norlite may propose CORMIX inputs and assumptions for outfall modifications in accordance with the Schedule of Compliance specified in the SPDES Permit.

## CORMIX MODELING

CORMIX is an industry accepted standard, and United States Environmental Protection Agency (US EPA) supported, mixing zone modeling program. This program can be used to model different outfall configurations, discharge rates and compositions, and ambient conditions. Arcadis utilized CORMIX Version 11.0 to conduct mixing zone modeling for the Outfall 006 reconfiguration.

## Relevant Mixing Zone Guidance Documents

NYS DEC guidelines for mixing zone dimensions, described in the Division of Water Technical and Operational Guidance Series (TOGS) (1.3.1), indicate that, in cases of incomplete mixing, the mixing in a stream or river should be:

- No more than 20 times the stream width for chronic criteria and
- No more than 50% of the cross-sectional area at the mixing length (which is no more than 20 times the stream width) for acute criteria.

Correspondence with the NYS DEC has indicated that the more stringent US EPA guidelines for establishing a mixing zone are currently being applied in New York. The US EPA Technical Support Document for Water Quality-based Toxics Control (EPA/505/2-90-001) provides four acute mixing zone alternatives:

1. No mixing zone. In this alternative, all concentrations will be below the criterion maximum concentration (CMC) at the end of the outfall pipe, before the discharge reaches the receiving water body.
2. High velocity discharge (greater than 3 m/s) with a mixing zone limited to 50 times the discharge length scale<sup>1</sup> in any spatial direction. The intent of this alternative is that the CMCs are met within a few minutes of discharge meeting the receiving water body.
3. Low velocity discharge (less than 3 m/s) with a mixing zone sized such that the CMCs are met within the most restrictive of the following criteria:
  - a. Ten percent of the distance from the edge of the outfall structure to the edge of the regulatory mixing zone<sup>2</sup> in any spatial direction.
  - b. Fifty times the discharge length scale in any spatial direction.
  - c. Five times the local water depth in any horizontal direction from any discharge outlet.
4. Data-validated assurance that a drifting organism in the specified mixing zone would not be exposed to 1-hour average concentrations exceeding the CMCs or other harmful exposure when evaluated by other valid toxicological analysis.

## Previously Evaluated Single Port Outfall Configuration

CORMIX Version 11.0 contains three alternatives for discharge configuration: CORMIX1 is for single-port discharges, CORMIX2 is for multiport diffuser discharges, and CORMIX3 is for surface discharges. The

---

<sup>1</sup> The discharge length scale is the square root of the cross-sectional area of any discharge pipe. In multiport outfall configurations, the discharge length scale is applied independently to each port.

<sup>2</sup> The NYS DEC has not established a regulatory mixing zone for this outfall location.

## OUTFALL 006 RECONFIGURATION REPORT

NYS DEC conducted baseline modeling of the existing outfall configuration, which reflected a surface, flush, brine discharge with a non-fresh receiving water body representing the 36-inch diameter outfall along the shoreline of the River (CORMIX3). The discharge velocity from the existing outfall was only 0.02 ft/s higher than the ambient velocity in the River, and as a result, the discharge did not project away from the bank into the River and no mixing was predicted by the NYS DEC CORMIX model.

Norlite's initial submittal of CORMIX input parameters proposed to increase the discharge velocity to yield jet-like mixing in the near field for a dilution ratio of 100 to 1, following NYS DEC's TOGS 1.3.1. The associated CORMIX input parameters were provided to the NYS DEC on April 2, 2018, revised to address NYS DEC comments and subsequently re-submitted on July 9, 2018. The proposed single-port outfall achieved 100:1 dilution within a 25-foot by 25-foot mixing zone in a CORMIX1 model. However, the same mixing zone sized using the EPA guidance document criteria for a high-velocity discharge resulted in a mixing zone that was limited in size to 4.44 feet in all directions due to the discharge length scale for the small port diameter and high discharge velocity. At that distance from the outfall, the dilution in this configuration was only 19.3:1, which was not sufficient to achieve compliance for water quality based effluent limits without significant modifications to the WWTP. The input parameters previously submitted to the NYS DEC are shown in Table 1.

## OUTFALL 006 RECONFIGURATION REPORT

Table 1. CORMIX1 Input Parameters – Single Port Outfall (Previously-Submitted)

CORMIX1 Input Fields	Proposed Value
<b>Effluent – Conservative Pollutant</b>	
Discharge Concentration (mg/L)	25,000 (Maximum)
Flow Rate (gpd)	120,000
Effluent Density (kg/m3)	1,010.53
<b>Ambient - Unbounded, Fresh Water</b>	
Average Depth (ft)	4.4
Depth at Discharge (ft)	5.0
Wind Speed (ft/s)	11.48
Velocity (ft/s)	0.24
Manning's n	0.03
Water Density (kg/m3)	997
<b>Discharge - CORMIX 1: Single Port</b>	
Nearest Bank	R
Distance to Bank (ft)	100
Port Diameter (ft)	0.1
Port Height from Bottom (ft)	3.5
Vertical – THETA (degrees)	0
Horizontal – SIGMA (degrees)	75
<b>Mixing Zone - Non-Toxic Effluent, WQ Standard</b>	
Concentration for the WQ Standard (Excess) (mg/L)	340
Region of Interest (ft)	3,000

Upon receiving the NYS DEC review comments, Norlite requested additional CORMIX modeling of a multiport diffuser configuration to reduce the discharge velocity while maintaining a high degree of mixing. NYS DEC agreed that Norlite could evaluate this option and present the proposed configuration in the Approvable Report required by the SPDES permit. The resulting multiport diffuser CORMIX model is presented in this Report and will be used as the basis for outfall reconfiguration design following NYS DEC approval.

## OUTFALL 006 RECONFIGURATION REPORT

In a September 2018 e-mail correspondence to Norlite, NYS DEC also provided several recommendations for additional modeling to be incorporated into the Approvable Report. These recommendations included the following:

1. *The CORMIX model and subsequent design must be evaluated at critical flow conditions (e.g. 7Q10) and off-design conditions (e.g. lower than normal process flows, higher than normal process flows, etc.).*
2. *The CORMIX model should avoid bottom attachment.*
3. *The CORMIX model for the multiport diffuser must minimize the merging of port plumes.*
4. *When developing the model, please pay attention to CORMIX warnings and provide justification of explanation for ignoring warnings. If there are real-world examples in support of the justification, please provide those cases.*

Discussion of how each of these comments is addressed is included in the following section.



## Proposed Multiport Outfall Configuration

For multiport discharge configurations, the US EPA guidance indicates that the same guidelines used for a single port discharge configuration will apply for sizing a mixing zone, but that the guidelines will be applied to each individual discharge port. In this case, with a multiport, CORMIX2 diffuser configuration, the discharge velocity will be less than 3 m/s, and the most restrictive criteria for mixing zone sizing will be fifty times the discharge length scale in any direction. The standard modeling approach for a multiport outfall is to utilize the CORMIX2 module. The proposed outfall configuration includes 10 ports oriented along a header directed in a downgradient direction in the Mohawk River. As such, the allowable mixing zone width based on the US EPA guidance would be approximately 74 feet. However, to maintain a design that occupies less than 10 percent of the total River width, the 10 ports were spaced closer together, as described below.

CORMIX2 models require input values for parameters relating to the receiving water body, facility effluent, and outfall configuration. Several parameters related to the ambient conditions in the River will remain unconfirmed until the detailed design phase of this project, which will include a bathymetric survey at the proposed outfall location. Therefore, a finalized CORMIX model and associated mixing zone will be prepared upon completion of the detailed design. Input parameters for the Norlite facility effluent were selected to represent conservative assumptions and the worst-case conditions; i.e. high effluent pumping rate, high density, and high TDS concentration. The input parameters used for the optimized multiport configuration are included in Table 2.

# OUTFALL 006 RECONFIGURATION REPORT

Table 2. CORMIX2 Input Parameters – Multiport Diffuser

CORMIX2 Input Fields	Proposed Value
<b>Effluent – Conservative Pollutant</b>	
Discharge Concentration (mg/L)	20,500
Flow Rate (gpd)	120,000
Effluent Density (kg/m <sup>3</sup> )	1,010.53
<b>Ambient - Unbounded, Fresh Water</b>	
Average Depth (ft)	4.4
Depth at Discharge (ft)	5.0
Wind Speed (ft/s)	11.48
Velocity (ft/s)	0.24
Manning's n	0.03
Water Density (kg/m <sup>3</sup> )	997
<b>Discharge - CORMIX2: Multiport</b>	
Nearest Bank	R
Diffuser Length (ft)	45
Distance to First Endpoint (ft)	105
Distance to Second Endpoint (ft)	150
Port Height (ft)	4
Port Diameter (ft)	0.167
Contraction Ratio	1
Total Number of Openings	10
Alignment Angle – GAMMA (degrees)	90
Vertical – THETA (degrees)	45
Horizontal – SIGMA (degrees)	0
Relative Orientation – BETA (degrees)	90
Nozzle Direction	Same Direction
<b>Mixing Zone - Non-Toxic Effluent, WQ Standard</b>	
Concentration for the WQ Standard (Excess) (mg/L)	340
Region of Interest (ft)	3,000

## OUTFALL 006 RECONFIGURATION REPORT

The effluent input parameters shown in Table 2 have not been modified since the previous submission to the NYS DEC (Response to DEC Comments on CORMIX Input Parameters for Norlite SPDES Permit No. NY0004880), except the TDS discharge concentration was revised from the overly conservative 25,000 mg/L back to the 20,500 mg/L initially provided by NYS DEC.

The ambient input parameters shown in Table 2 also have not been modified from the previous submission and represent conservative assumptions. If future bathymetric survey reveals that the average depth or velocity is different during 7Q10 flows than reflected in the current CORMIX model, these input parameters will be modified to more closely reflect field conditions in the detailed design to achieve the best practicable mixing.

The proposed multiport discharge configuration includes a 45-foot header, occupying less than 10 percent of the river width, with ten (10) 2-inch ports. Each port is on a separate riser, extending four feet above the River bottom with the top 3 to 6 inches, angled 45 degrees toward the River's surface, oriented downstream.

The proposed outfall design was selected to optimize dilution within the mixing zone boundary. With 2-inch diameter ports, the mixing zone can extend a maximum of 7.39 feet (2.25 meters) from each port opening in all directions.

Due to the density of the discharge, preventing bottom attachment is not easily accomplished, but limiting the size of the mixing zone to a smaller area, such that bottom attachment occurs beyond the chronic mixing zone boundary, is feasible. In the CORMIX2 model, the downstream distance at which the model indicates the effluent has reached the River bottom is approximately 24.99 feet (7.62 meters), which is well beyond the allowable mixing zone boundary as determined by applying the discharge length scale. This addresses the NYS DEC comment that the CORMIX model should not indicate bottom attachment.

The results of the CORMIX2 multiport model run require some interpretation and further evaluation because CORMIX2 treats this configuration as a slot discharge, when run with the effluent flow rate of 120,000 gpd. In the model's Session Report (one type of output file from a CORMIX model run), a slot discharge is described as an approximation of the merging process of the individual jets from each port or nozzle. The Session Report further indicates that the slot approximation "holds well" because the spacing between the ports is on the order of, or less than, the local water depth. In the multiport CORMIX2 model, the results indicate that at the mixing zone boundary, the dilution would be on the order of 168:1 and the effluent would not yet have significant bottom interaction. Since the NYS DEC maximum dilution allowed for SPDES permits is 100:1, if the multiport model is accepted, the requested dilution will be 100:1 at the mixing zone boundary.

While the multiport model (CORMIX2) is the appropriate CORMIX module for dilution and mixing results in this application, it approximates the details of the merging process of the individual jets from each port/nozzle. The CORMIX2 model output for this outfall configuration does not provide high enough resolution for the distinct port plumes in the near field.

To evaluate mixing in the near field and to better understand what effluent coming from each individual port looks like, a second model was run using CORMIX1 (i.e. a CORMIX model treating each port as a single port diffuser). If the 10 ports are spaced evenly along the 45-foot diffuser header, each port has 5 feet of available width, centered on the port, before the plumes would begin to overlap.

## OUTFALL 006 RECONFIGURATION REPORT

To address the DEC comment that merging of port plumes should be minimized, the single port CORMIX1 model was run to approximate mixing from one individual port (i.e., one of the 10 ports). In the single port CORMIX1 model, the results indicate that the dilution at the mixing zone boundary would be 64:1. At the mixing zone boundary (7.39 feet or 2.25 meters), the plume centerline will have reached the bottom of the river in 7Q10 flows. The CORMIX1 model indicates that the effluent will reach the River bottom at approximately 7.02 feet (2.14 meters) downstream of the diffuser ports. At this distance, the dilution is approximately 53:1 with a total width of less than 5 feet, therefore confirming adequate spacing without merging of the individual plumes. The input parameters for the single port CORMIX1 model are provided in Table 3. Both the CORMIX2 and CORMIX1 input files have also been provided electronically with this Report. By modeling the multiport diffuser using both the CORMIX1 and CORMIX2 modules, the interpreted results should provide adequate support to address the minimizing of merging of port plumes as stated in the third NYS DEC comment.

## OUTFALL 006 RECONFIGURATION REPORT

**Table 3. CORMIX1 Input Parameters – Ten Single Port Diffusers**

CORMIX1 Input Fields	Proposed Value
<b>Effluent – Conservative Pollutant</b>	
Discharge Concentration (mg/L)	20,500
Flow Rate (gpd)	12,000
Effluent Density (kg/m <sup>3</sup> )	1,010.53
<b>Ambient - Unbounded, Fresh Water</b>	
Average Depth (ft)	4.4
Depth at Discharge (ft)	5.0
Wind Speed (ft/s)	11.48
Velocity (ft/s)	0.24
Manning's n	0.03
Water Density (kg/m <sup>3</sup> )	997
<b>Discharge – CORMIX1: Single Port</b>	
Nearest Bank	R
Distance to Bank (ft)	100
Port Diameter (ft)	0.167
Port Height from Bottom (ft)	4
Vertical – THETA (degrees)	45
Horizontal – SIGMA (degrees)	0
<b>Mixing Zone - Non-Toxic Effluent, WQ Standard</b>	
Concentration for the WQ Standard (Excess) (mg/L)	340
Region of Interest (ft)	3,000

As requested by the NYS DEC, the CORMIX model was run at 7Q10 ambient flows, which is a typical approach for mixing zone dilution modeling. The proposed design for Outfall 006 will be a pumped discharge from the Norlite facility to the River, and therefore will have a nearly constant fixed flow rate (either on or off) into the River via the reconfigured outfall. It is not anticipated that it will operate at flows deviating from design conditions. However, to satisfy the request of the NYS DEC, both the CORMIX2 and the CORMIX1 models were run at half of the maximum effluent pumping capacity at the 7Q10 river flow to analyze what may occur if the pumps at the Norlite facility are not operating as designed. In both cases, dilution improved with the lower flow rate.

The final comment in the NYSDEC e-mail stated that all warning messages in the CORMIX output files should be thoroughly reviewed. There were no significant warning messages provided in the CORMIX output for either model run; there was an indicator in the CORMIX2 model to review a CORMIX1 model replicating one of the ports from the multipoint diffuser, which was completed as described above.

## PROPOSED DESIGN

The proposed outfall reconfiguration will require extending the existing 4-inch Norlite force main to the diffuser header in the River. The proposed route for the 4-inch force main, shown in Figure 1, connects to the existing force main at the intersection of Bridge Street and New York State Route 32 (Cohoes Road), on the east side of the railroad. The force main extension will be constructed along the east side of Cohoes Road, run along the outside of the Mohawk Paper and U-Haul/self-storage facility parcel boundaries, around the southern boundary of the U-Haul/self-storage facility boundary and turn to the north, running parallel to the west of New York State Route 787. The force main will continue north until it intersects the 36-inch City of Cohoes storm sewer. From this point to the River, the force main will be installed within the storm sewer (if possible), or adjacent to the storm sewer (if required), crossing under New York State Route 787. It is expected that portions of the force main installation will be open cut, while other areas may be installed using trenchless technologies such as directional drilling.

Preliminary design discussions with the City of Cohoes, have identified several measures that will need to be taken to ensure there will be no harmful impacts the City's storm sewer resulting from the proposed pipe-within-a-pipe Norlite outfall reconfiguration. To address the City's concerns and obtain their approval, the following tasks will be completed during detailed design:

1. Complete a CCTV inspection of the 36-inch stormwater line: The City Engineer reported that this stormwater line is over 50 years old and that its structural condition is unknown. An inspection would allow the structural integrity of the stormwater pipe to be verified prior to the installation of the 4-inch Norlite outfall pipe within the City's stormwater pipe.
2. Perform an analysis of the stormwater network upgradient of the City's stormwater outfall: This would include a review of the capacity of the drainage network attached to the 36-inch stormwater outfall pipe. Though Norlite effluent is currently discharged through the 36-inch stormwater outfall, the City will require engineering verification that the modification to confine the Norlite flow to a 4-inch pipe within the 36-inch pipe would not affect the capacity of the City's storm sewer or cause additional system back-up.

Both of these measures will be completed as early as possible with City coordination during the detailed design phase of the project.

If it is discovered during the detailed design phase that the 36-inch storm sewer will not accommodate installation of the new force main or does not have the capacity to accommodate a 4-inch pipe during a design storm event, the 4-inch force main will be constructed parallel to the storm sewer within the City's storm sewer easement. The 4-inch force main will maintain a minimum of 4 feet of ground cover or water cover, meaning that at the bank of the River, the 4-inch force main will be bored underground into the River until it reaches a point where there will be a minimum water depth of 4 feet at 7Q10 flow. At the location with a minimum depth of 5 feet at 7Q10 flows, the diffuser header and risers will be installed. This available depth is anticipated to be at least 50 feet from the shoreline but will be confirmed during detailed

## OUTFALL 006 RECONFIGURATION REPORT

design. Note that the option to install the force main parallel to the City's 36-inch storm sewer is not preferred as it may require boring/jacking a new casing pipe beneath New York State Route 787. A location plan of the multiport diffused outfall is shown in Figure 2. A conceptual detail for one of the risers including a support structure and floating obstruction indicator is included as Figure 3.

### Constructability

The outfall reconfiguration will require four main components:

1. Evaluating the additional pumping required to maintain a pumping rate of 120,000 gpd to the River and installing new pumping components if necessary
2. Lengthening the existing 4-inch force main by approximately 2,350 feet.
3. Installing 2 new manholes on the 36-inch storm sewer for access to, and installation of, the lengthened force main.
4. Installing the multiport diffuser in the River.

Installation of the 4-inch force main extension within the 36-inch City of Cohoes storm sewer will greatly simplify the construction process because it will eliminate approximately 750 linear feet of open cut or trenchless excavation. Assuming the results of the CCTV inspection and hydraulic analysis indicate that installation of the 4-inch force main inside of the 36-inch storm sewer will be a safe and viable option, there will be two locations where new access structures will be placed for the force main to enter and exit the storm sewer. One new access structure will be in the Route 787 right of way, on the west side of Route 787 near the Mohawk Paper property. The other new access structure will be constructed near the River's edge to provide a location for the 4-inch force main to exit the 36-inch storm pipe. Proposed approximate locations for these structures are shown on Figure 1. Details for the force main entrance and exit to/from the storm sewer are provided in Figures 4 and 5.

The new structures will both be dog house type manholes constructed around the existing 36-inch storm sewer and sized (during detailed design) to allow the 4-inch HDPE force main to bend through the structures as it enters or exits the storm sewer. The force main will need to be anchored at these new structures and at the entrance and exit of existing catch basin or manhole along the storm sewer route. Based on the City of Cohoes' available mapping, this will be a minimum of 4 locations, plus the two new access structures.

Force main installation at the entrance to the River will have a minimum of 5 feet of cover for frost protection. The force main will be installed with at least 2 feet of cover and will be at least 5 feet below the 7Q10 river elevation to provide protection from freezing, ice loading, and debris as shown on Figure 2. During the detailed design phase, additional evaluation will be conducted to determine if additional anchoring either within the storm sewer or under the River's surface is necessary.

It is likely that the extension of the force main within the 36-inch sewer will need to occur from the downstream end of the storm pipe, where it currently discharges into the River. The fusion-welded HDPE pipe will likely be assembled and installed upstream, into the 36-inch pipe to its terminus at the new access structure on the west side of Route 787. Once the HDPE pipe is installed in the 36-inch storm sewer, it will then be cut to length at the second access structure, where the 4-inch force main will exit the 36-inch storm pipe and remain buried at a minimum depth to avoid freezing. The new pipe will then run

## OUTFALL 006 RECONFIGURATION REPORT

perpendicular to the River's edge and extended into the river as described above. The diffuser header will be Installed as shown on Figure 2.

Steel H-piles will be installed upgradient of each riser for protection. These supports will be installed to one foot below the 7Q10 river elevation and will have an estimated 8 feet of embedment. The protective H-piles will be driven into the River bottom (likely from a barge) or cored and grouted into bedrock. As an alternative to steel H-piles for protection, a flexible coupling will be considered for installation at the bottom of the diffuser and risers. This configuration would allow movement if/when impacted by watercraft or other debris but remain vertical at all other times. A floating buoy would still be anchored to the River bottom if the flexible design is constructed, to indicate riser locations.

During construction, coffer dams will be used for dewatering excavations as necessary. Additionally, turbidity curtains will be employed to minimize disturbance to surrounding areas.

If the reconfigured outfall cannot be constructed in a way that will align with the CORMIX modeling intended for use in the SPDES permit development, the CORMIX model will be further revised during the detailed design. If any modifications are made, finalized CORMIX input parameters will be provided with the detailed design for NYS DEC for review.

### Detailed Design Phase

The design for the reconfigured Outfall 006 is currently at the conceptual level, though many discussions with key stakeholders have already taken place. These discussions have established several elements that will need to be included in the detailed design phase, which is anticipated to begin upon NYS DEC approval of this Report.

### Permitting and Approvals

Norlite is in the process of negotiating easements for installation of the force main on private properties and anticipates executing agreements during the detailed design phase. Approvals are anticipated to be needed for installation of the new force main extension in public rights of way (ROW) for Saratoga Ave, NYS Route 787 and the City of Cohoes ROW (including installation of the force main inside the 36-inch storm sewer), which will also be coordinated during the detailed design phase.

In addition, it is anticipated that, at a minimum, permitting and/or approvals will be needed for the following:

- State Environmental Quality Review (SEQR)
- United States Army Corps of Engineers (US ACE) / NYS DEC Joint Application Form for activities affecting streams, waterways, wetlands, coastal areas, sources of water and endangered and threatened species.
- New York State Historic Preservation Office (SHPO) review



## Force Main Hydraulic Analysis

A detailed hydraulic evaluation will be completed in the detailed design phase of this project to analyze current pumping capabilities and future required pumping capacity. A preliminary analysis indicates that the topography of Cohoes is such that minimal additional pumping head will be incurred because of the small elevation change between the Norlite facility and the River. Norlite effluent will be pumped from an on-site holding tank to the River, which has an elevation decline of approximately 30 feet, assuming a River water level at elevation 20 feet. The total 4-inch force main length from the Norlite facility to the River will be approximately 5,600 feet. At the desired flow rate over that distance, there will be an estimated 54 feet of dynamic head loss, which exceeds the elevation change from the Norlite facility to the outfall by an estimated 24 feet. The existing pumps will be evaluated during detailed design to verify whether they can be modified to handle the additional head, or whether new pumps will be needed.

## Bathymetric Survey

The 10-port diffuser construction in the River will require some logistical considerations. During detailed design, a bathymetric survey will be completed to identify and select the location for diffuser construction along the River bottom. It is anticipated that this location will be between 50 and 100 feet from the Riverbank during 7Q10 flows. As the diffuser is constructed, temporary barriers will need to be utilized to divert flows around the diffuser. To the extent practical, construction activities will be planned to be completed during seasonal low flows, to minimize disturbance to the River.

## Maintenance Requirements

The proposed outfall will need to be visually inspected annually as well as following significant storm events to ensure the diffuser risers remain in working condition. Since the outfall design includes risers extending up from the River bottom to distribute the high-density discharge, the risk of impact to the risers is high. To prevent watercraft from causing damage to the risers, Norlite will consider placing buoys on the surface or constructing a protective structure above the water surface to warn River recreational users.

Annual visual inspections will require divers to adequately assess submerged conditions. During inspections, provisions will be on hand for the divers to make minor repairs if needed. The need for major repairs will be documented and other methods may be required, such as boats or larger equipment to make those repairs.

## Reliability

The long-term reliability of the proposed outfall configuration will be considered during the detailed design phase. The outfall will be a pumped discharge of treated effluent, and the existing force main does not have a history of scaling or other fouling as the discharge occurs directly from the treatment process and does not contain high quantities of solids. Therefore, plugging from the facility effluent is not anticipated to be a problem. There is a potential risk of backflow or aquatic organisms entering the 2-inch riser pipes, which will be addressed during detailed design. Potential means of addressing this may include incorporating check valves (i.e., Tideflex check valves) at the discharge points.

## OUTFALL 006 RECONFIGURATION REPORT

Risk of damage to the reconfigured outfall will be minimized by burying the header pipe as described above, and by incorporating H-piles on the upstream side of each riser and diffuser for support and protection. If the flexible coupling risers are pursued as an alternative to using the H-piles, their design will be sufficiently reviewed for reliability to ensure the risk of damage from impact is minimized and so that performance will not be compromised. An evaluation of the potential for ice loading around and upgradient of these supports will be conducted during the detailed design phase. Further evaluation of alternative and additional protective measurements will be conducted during the detailed design as well. If a riser is discovered to be damaged after installation, it will be repaired as quickly as possible upon discovery and an analysis will be conducted to understand the cause of the damage and what further protective measures may be implemented to prevent recurrence of the damage.

### OUTFALL RECONFIGURATION ALTERNATIVE

NYS DEC has requested that in conjunction with this 'Approvable Report' for the CORMIX Dilution Study and proposed construction schedule, Norlite provide any potential alternative Outfall Designs or system changes to achieve compliance with the final effluent limits. As NYS DEC is aware, Norlite intends to eliminate all discharge through 006, 06A and 06C outfalls. This will be accomplished through Project Delta, an upgrade of the facility's Air Pollution Control (APC) system. This entails a semi-dry system which will produce no scrubber blowdown water for treatment and discharge through the SPDES permit. Norlite intends to finalize the APC upgrades prior to any SPDES Schedule of Compliance deadlines required by the current permit. Norlite will continue to communicate these changes through a permit modification request as discussed with the NYS DEC Regional Permit Administrator.

### PROPOSED DESIGN AND CONSTRUCTION SCHEDULE

The detailed design is expected to include internal project reviews with Norlite at 30-, 90-, and 100-percent completion. The compliance action table included in the current Norlite facility SPDES permit (NY0004880) indicates that the Permittee shall complete construction as outlined in this Approvable Report within 2 years of the Department's approval date. It is anticipated that construction will require 9 months and that permitting and approvals will require at least 3 months, allowing up to 1 year for design. The NYS DEC will need to be notified by Norlite in the event that there are delays that will prevent adherence to this schedule.

# FIGURES

Figure 1. Proposed Force Main Extension



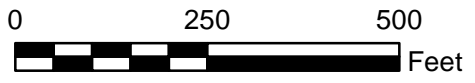

**Legend**

- Approximate Path of Existing 36" Storm Sewer
- - - Proposed Path of 4" Norlite Effluent Force Main Extension
- ⊕ Storm Manholes
- ⊕ Proposed Dog House Type Manhole Location
- Proposed Mixing Zone

Tradebe/Norlite, LLC  
Cohoes, NY

SPDES Permit No. NY0004880

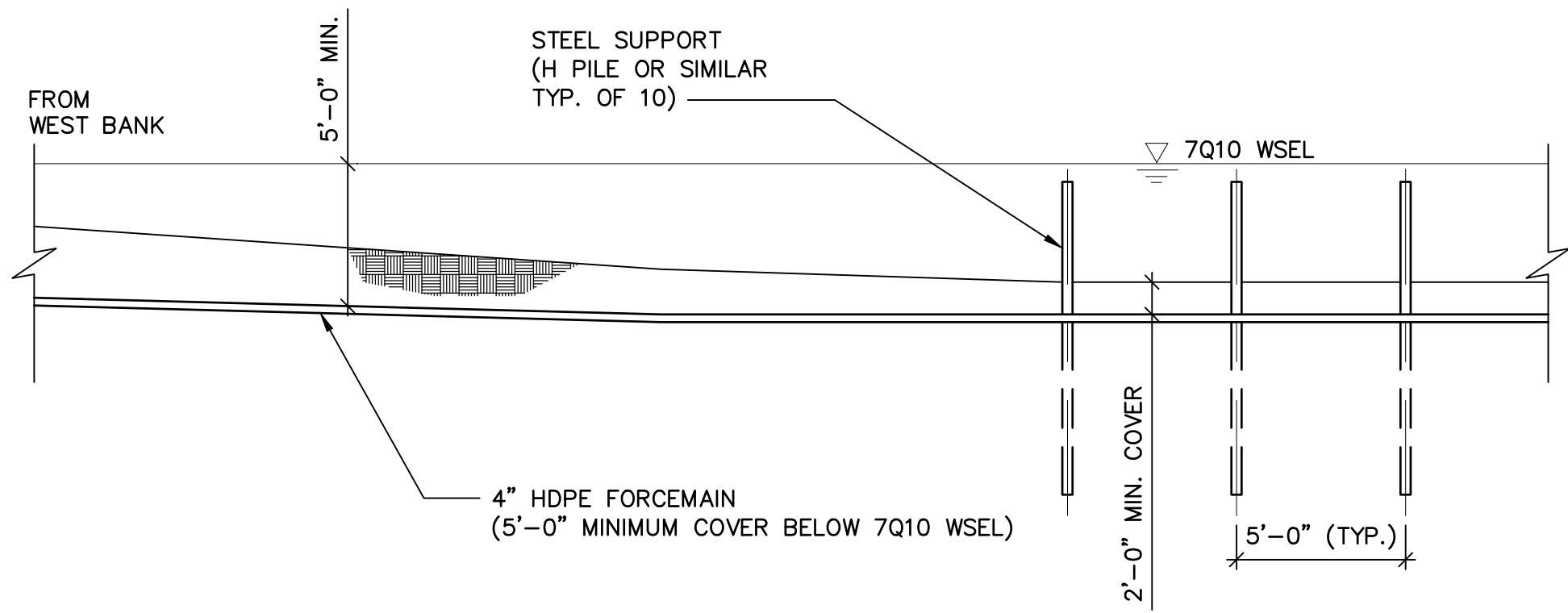



FIGURE  
**1**

# FIGURES

Figure 2. Outfall Port Spacing





TRADEBE/NORLITE, LLC COHOES, NEW YORK <b>OUTFALL 006 RECONFIGURATION</b>	
<b>OUTFALL PORT SPACING</b>	
 <b>ARCADIS</b>	Design & Consultancy for natural and built assets
<b>FIGURE 2</b>	

# FIGURES

Figure 3. Outfall 006 Detail



USER: ABROOKS FILENAME: G:\PROJECT\02475035.0000\CADD\OUTFALL DETAIL.DWG SAVE DATE: 11/5/2018 2:23 PM PLOT DATE: 11/5/2018 4:06 PM

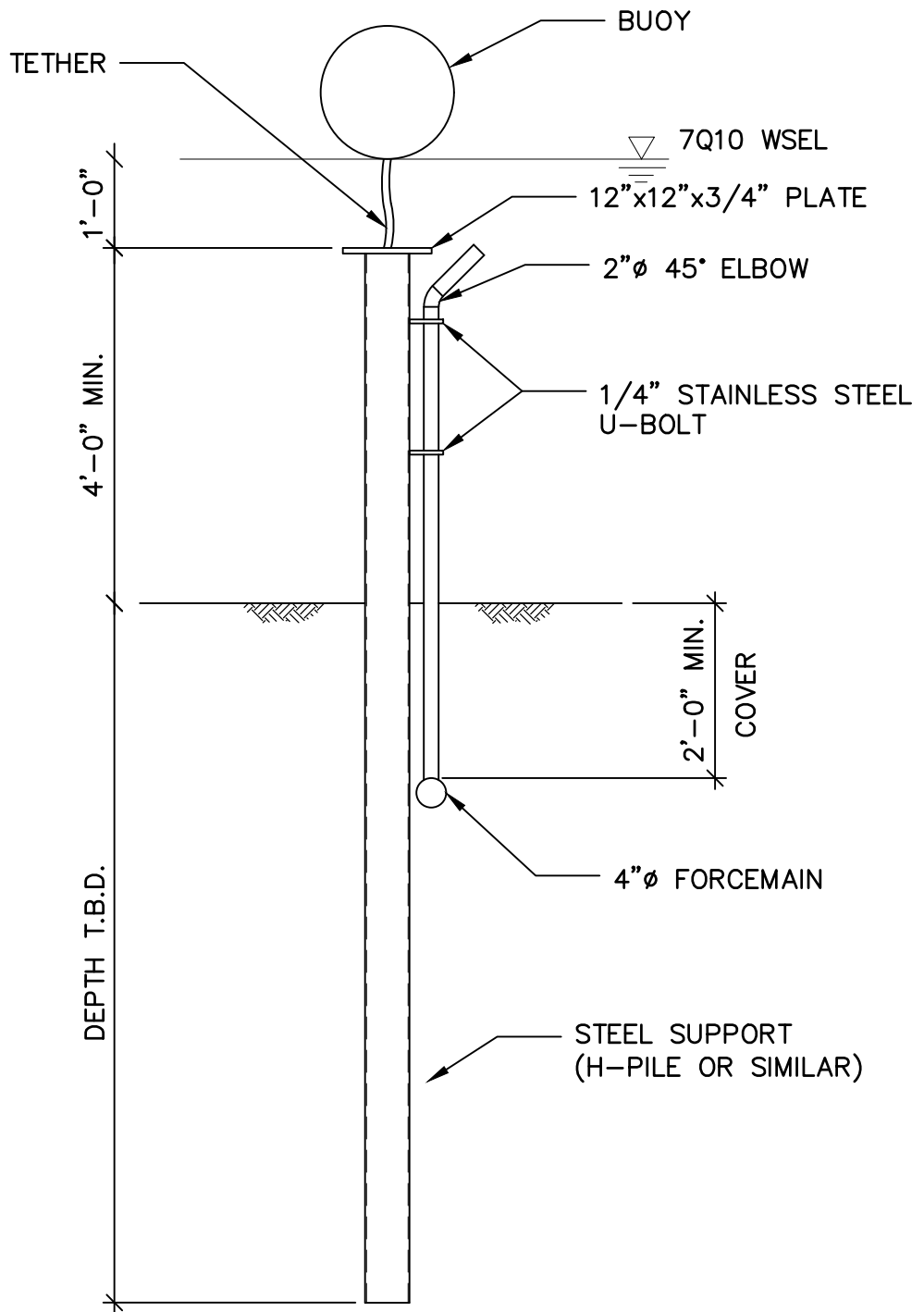

TRADEBE/NORLITE, LLC  
COHOES, NEW YORK  
**OUTFALL 006 RECONFIGURATION**

**OUTFALL 006 DETAIL**



# FIGURES

Figure 4. Doghouse Manhole Detail



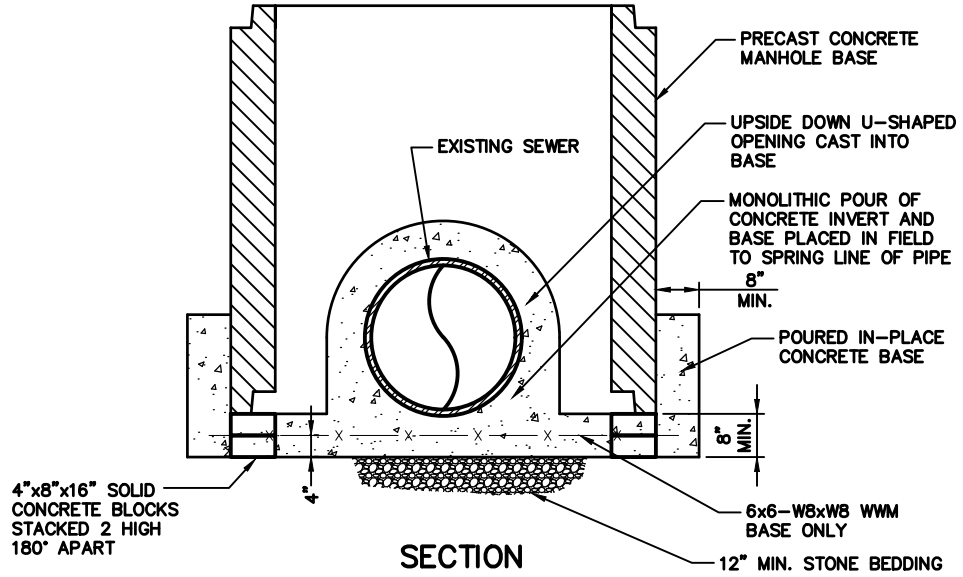

CUT AND REMOVE TOP HALF OF PIPE  
INSIDE MANHOLE AFTER CONCRETE IS  
SET AND ACCEPTED, REMOVE  
ADDITIONAL PIPE AS NECESSARY TO  
PROVIDE ACCESS TO BENCH TROUGHS

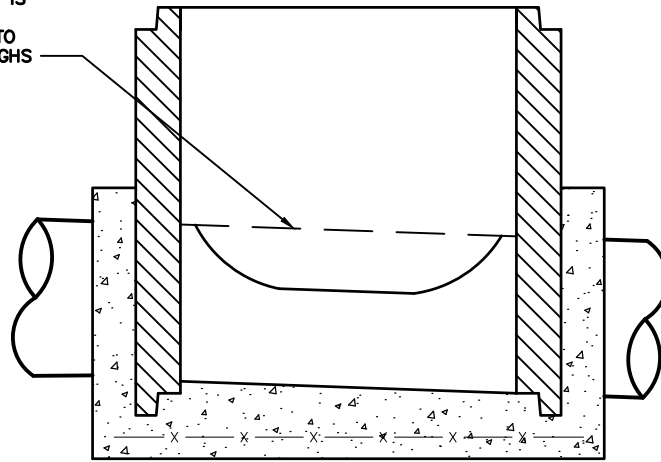

### PROFILE

### NOTES:

1. USE CLASS "A" CONCRETE IN ALL POURS.
2. STANDARD BARREL SECTIONS, CONE, COVER, SEALANTS, MORTAR, ETC. ABOVE BASE PER MANHOLE DETAIL ON THIS SHEET.

TRADEBE/NORLITE, LLC  
COHOES, NEW YORK  
**OUTFALL 006 RECONFIGURATION**

**DOGHOUSE MANHOLE DETAIL**

# FIGURES

Figure 5. Entrance and Exit Manhole Details



User: ABROOKS Spec: AUS-NCSMOD File: C:\PROJECT\02475035.0000\CADD\ENTRANCE & EXIT MANHOLES.DWG  
Scale: 1:1 SavedDate: 11/5/2018 Time: 16:08 Plot Date: Brooks, A.J.; 11/5/2018; 16:08 ; Layout: BLANK

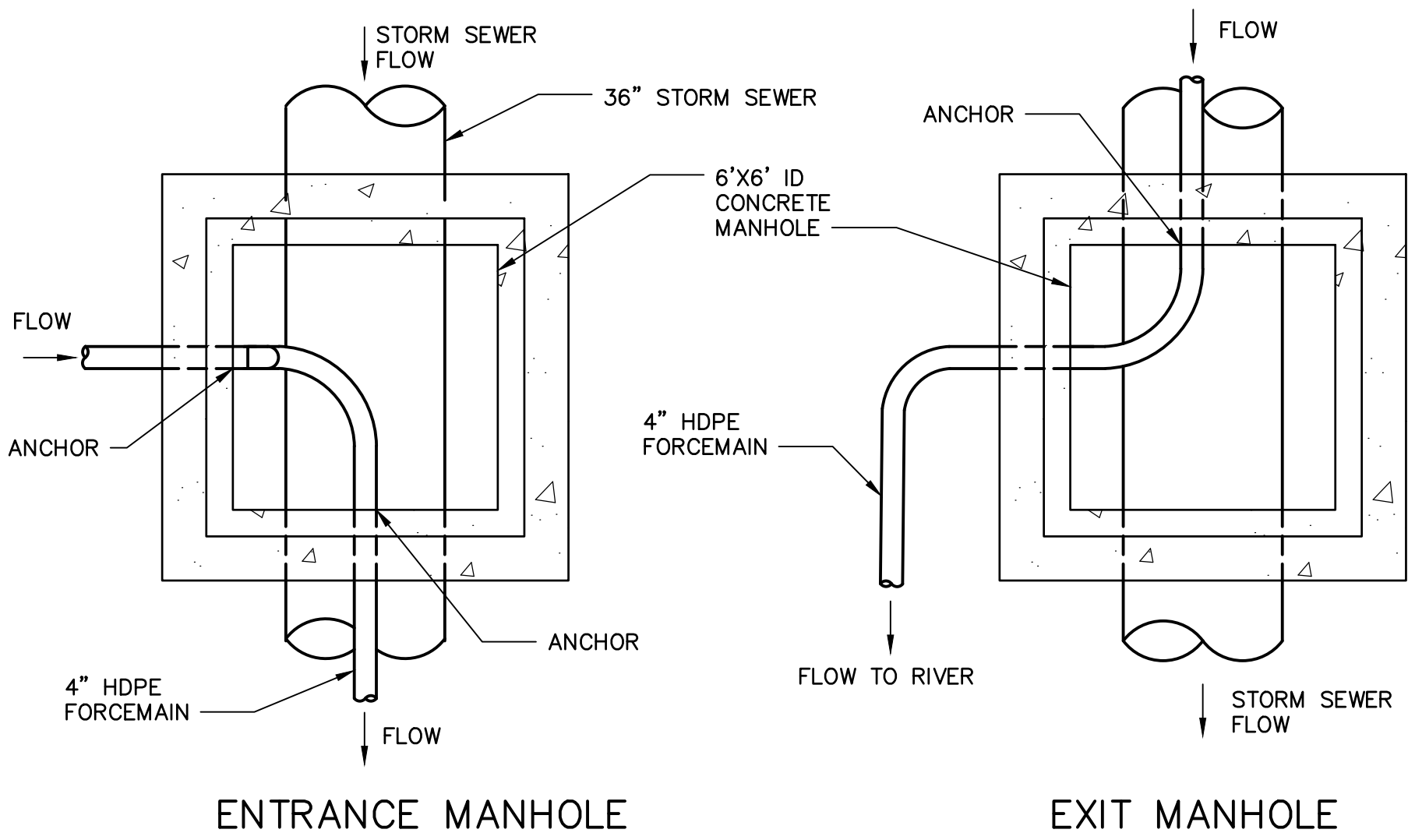

TRADEBE/NORLITE, LLC COHOES, NEW YORK <b>OUTFALL 006 RECONFIGURATION</b>	
<b>ENTRANCE &amp; EXIT MANHOLE DETAILS</b>	
 <b>ARCADIS</b> Design & Consultancy for natural and built assets	<b>FIGURE 5</b>

Arcadis of New York, Inc.

855 Route 146

Suite 210

Clifton Park, New York 12065

Tel 518 250 7300

Fax 518 371 2757

[www.arcadis.com](http://www.arcadis.com)