



Department of
Environmental
Conservation

State Pollutant Discharge Elimination System (SPDES) DISCHARGE PERMIT

SIC Code: 2084	NAICS Code: 312130	SPDES Number:	NY0281921
Discharge Class (CL): 04	DEC Number:		3-1356-00322/00002
Toxic Class (TX): N	Effective Date (EDP):		EDP
Major-Sub Drainage Basin: 13 - 01	Expiration Date (ExDP):		EDP + 10 Years
Water Index Number: -	Item No.: -	Modification Dates (EDPM):	
Compact Area: -			

This SPDES permit is issued in compliance with Title 8 of Article 17 of the Environmental Conservation Law of New York State and in compliance with the Clean Water Act, as amended, (33 U.S.C. '1251 et.seq.)

PERMITTEE NAME AND ADDRESS			
Name:	Obercreek PL	Attention:	Alexander Reese, Owner
Street:	P. O. Box 230		
City:	Hughsonville	State:	NY Zip Code: 12537
Email:	alexreese@aol.com	Phone:	(914) 475-5195

is authorized to discharge from the facility described below:

FACILITY NAME, ADDRESS, AND PRIMARY OUTFALL										
Name:	Obercreek Brewery & Tasting Room									
Address / Location:	81 New Hamburg Road						County:	Dutchess		
City:	T/ Wappinger				State:	NY		Zip Code:	12590	
Facility Location:	Latitude:	41 °	35 '	2.6 " N	& Longitude:	73 °	56 '	7.5 " W		
Primary Outfall No.:	001	Latitude:	41 °	35 '	7.49 " N	& Longitude:	73 °	56 '	1.72 " W	
Wastewater Description:	Sanitary & Brewery	Receiving Water:	Groundwater		NAICS:	312130		Class:	GA Standard: GA	

in accordance with: effluent limitations; monitoring and reporting requirements; other provisions and conditions set forth in this permit; and 6 NYCRR Part 750-1 and 750-2.

This permit and the authorization to discharge shall expire on midnight of the expiration date shown above and the permittee shall not discharge after the expiration date unless this permit has been renewed or extended pursuant to law. To be authorized to discharge beyond the expiration date, the permittee shall apply for permit renewal not less than 180 days prior to the expiration date shown above.

DISTRIBUTION:

R3 Permit Coordinator
R3 Permit Writer
RWE
RPA

Permit Administrator:			
Address:			
Signature:		Date:	

DEFINITIONS

TERM	DEFINITION
7-Day Geo Mean	The highest allowable geometric mean of daily discharges over a calendar week.
7-Day Average	The average of all daily discharges for each 7-days in the monitoring period. The sample measurement is the highest of the 7-day averages calculated for the monitoring period.
12-Month Rolling Average (12 MRA)	The current monthly value of a parameter, plus the sum of the monthly values over the previous 11 months for that parameter, divided by the number of months for which samples were collected in the 12-month period.
30-Day Geometric Mean	The highest allowable geometric mean of daily discharges over a calendar month, calculated as the antilog of: the sum of the log of each of the daily discharges measured during a calendar month divided by the number of daily discharges measured during that month.
Action Level	Action level means a monitoring requirement characterized by a numerical value that, when exceeded, triggers additional permittee actions and department review to determine if numerical effluent limitations should be imposed.
Compliance Level / Minimum Level	A compliance level is an effluent limitation. A compliance level is given when the water quality evaluation specifies a Water Quality Based Effluent Limit (WQBEL) below the Minimum Level. The compliance level shall be set at the Minimum Level (ML) for the most sensitive analytical method as given in 40 CFR Part 136, or otherwise accepted by the Department.
Daily Discharge	The discharge of a pollutant measured during a calendar day or any 24-hour period that reasonably represents the calendar day for the purposes of sampling. For pollutants expressed in units of mass, the 'daily discharge' is calculated as the total mass of the pollutant discharged over the day. For pollutants with limitations expressed in other units of measurement, the 'daily discharge' is calculated as the average measurement of the pollutant over the day.
Daily Maximum	The highest allowable Daily Discharge.
Daily Minimum	The lowest allowable Daily Discharge.
Effective Date of Permit (EDP or EDPM)	The date this permit is in effect.
Effluent Limitations	Effluent limitation means any restriction on quantities, quality, rates and concentrations of chemical, physical, biological, and other constituents of effluents that are discharged into waters of the state.
Expiration Date of Permit (ExDP)	The date this permit is no longer in effect.
Instantaneous Maximum	The maximum level that may not be exceeded at any instant in time.
Instantaneous Minimum	The minimum level that must be maintained at all instants in time.
Monthly Average	The highest allowable average of daily discharges over a calendar month, calculated as the sum of each of the daily discharges measured during a calendar month divided by the number of daily discharges measured during that month.
Outfall	The terminus of a sewer system, or the point of emergence of any waterborne sewage, industrial waste or other wastes or the effluent therefrom, into the waters of the State.
Range	The minimum and maximum instantaneous measurements for the reporting period must remain between the two values shown.
Receiving Water	The classified waters of the state to which the listed outfall discharges.
Sample Frequency / Sample Type / Units	See NYSDEC's "DMR Manual for Completing the Discharge Monitoring Report for the SPDES" for information on sample frequency, type and units.

PERMIT LIMITS, LEVELS AND MONITORING

OUTFALL	DESCRIPTION	RECEIVING WATER	EFFECTIVE	EXPIRING
001	Sanitary + Brewery	Groundwater	EDP	ExDP

PARAMETER	EFFLUENT LIMITATION					MONITORING REQUIREMENTS				FN
	Type	Limit	Units	Limit	Units	Sample Frequency	Sample Type	Location		
								Inf.	Eff.	
Flow	Daily Maximum	Monitor	MGD			Continuous	Meter	X		1
pH	Daily Minimum	6.5	SU			Quarterly	Grab		X	2
	Daily Maximum	8.5	SU							
BOD ₅	Daily Maximum	Monitor	mg/L			Quarterly	Grab		X	2, 3
Total Suspended Solids (TSS)	Daily Maximum	Monitor	mg/L			Quarterly	Grab		X	2, 3
Total Dissolved Solids (TDS)	Daily Maximum	Monitor	mg/L			Quarterly	Grab		X	2, 3
Total Phosphorus (as P)	Daily Maximum	Monitor	mg/L			Quarterly	Grab		X	2, 3
Total Nitrogen (as N)	Daily Maximum	Monitor	mg/L			Quarterly	Grab		X	2, 3, 4

FOOTNOTES:

- Metered flow to be measured at start of treatment system. Daily max must be recorded and monthly max reported quarterly.
- Quarterly samples shall be collected in calendar quarters (Q1 – January 1st to March 31st; Q2 – April 1st to June 30th; Q3 – July 1st to September 30th; Q4 – October 1st to December 31st).
- Indicator concentrations: BOD₅ = 150 mg/L, TSS = 100 mg/L, TDS = 500 mg/L, Total Phosphorus (as P) = 15 mg/L, Total Nitrogen (as N) = 50mg/L. Quarterly samples shall be taken at the last stage of treatment prior to discharge to the subsurface treatment system. If your quarterly sample results in concentrations above these indicator concentrations, then the subsurface system is receiving higher than advisable concentrations. The permittee should assess their system and take actions to correct any problems identified. Continuous exceedances may result in subsurface treatment failure.
- Total Nitrogen (as N) = [Total Kjeldahl Nitrogen (TKN), as N] + [Nitrite (NO₂), as N] + [Nitrate (NO₃), as N].

SPECIAL CONDITIONS

A. **Proposed or Modified Treatment**

Discharges from proposed disposal systems, or increases in discharge from the modification or replacement of existing disposal systems are not authorized until appropriate action is taken as follows:

- (1) Submit to the Regional Water Engineer an approvable engineering report, plans, and specifications that have been prepared by a Professional Engineer licensed to practice in the New York State in accordance with standards accepted by the Department (discussed below);
- (2) The construction of such a modified disposal system shall not start until the discharger receives written approval of the system from the Department. The Department may require the discharger to remove any constructed disposal system or portion thereof if such a system or portion thereof is constructed prior to written approval from the Department;
- (3) The construction of such a modified system shall be under the general supervision of a P.E. Upon completion of construction, the P.E. shall certify to the Department that the disposal system has been fully completed in accordance with the approved engineering report, plans, and specifications; permit and letter of approval; and the permittee shall receive written acceptance of such certificate from the Department prior to commencing discharge.

B. **Design Standards**

- (1) Flow equalization to address the expected variability in hourly, daily and seasonal wastewater generation;
- (2) Adequate controls to ensure the system does not receive process wastewater that exceeds the system's design flow or has a strength or characteristic beyond the design capability of the system;
- (3) Subsurface treatment system shall be designed in accordance with the New York State Design Standards for Intermediate Sized Wastewater Treatment Systems. Special consideration should be directed to the provisions addressing high strength wastewater.

C. **Septic Tanks**

If a Septic Tank is installed as part of the treatment system (existing or new), it shall be inspected by a Professional Engineer licensed to practice in New York State, a National Association of Wastewater Technician (NAWT)-certified inspector, or a NY Onsite Wastewater Treatment Training Network (OTN)-registered inspector for scum and sludge accumulation at intervals not to exceed one year's duration, and that such accumulation will be removed before the depth of either exceeds one-fourth (1/4) of the liquid depth so that no settleable solids or scum will leave in the septic tank effluent. Additionally, the septic tank shall be pumped at a minimum of once every three (3) years. Such accumulation shall be disposed of in accordance with all applicable law and regulation [6 NYCRR 750-2.8(d)]. Records of the annual inspection and scum and sludge removal must be maintained on site for a minimum period of five (5) years.

D. **Quarterly Visual Inspection**

Quarterly Visual Inspection of the subsurface treatment system to determine if any spongy ground, ponding, breakout, or other signs of system failure are evident. If signs of failure are discovered, the permittee must act to prevent a discharge to surface waters and follow procedures outlined in 6 NYCRR 750-2.7.

MONITORING LOCATIONS

The permittee shall take samples and measurements, to comply with the monitoring requirements specified in this permit, at the location(s) specified below:

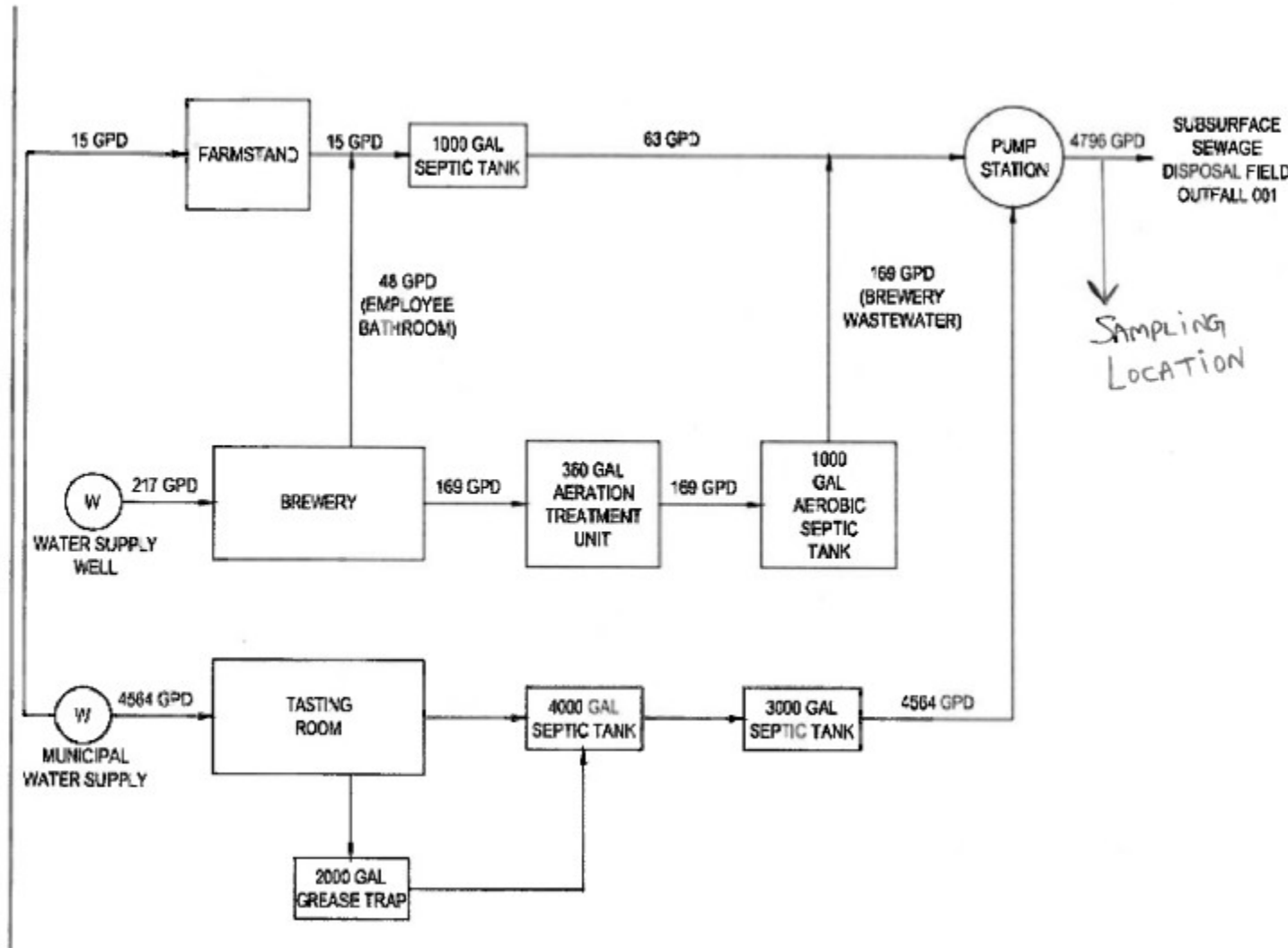

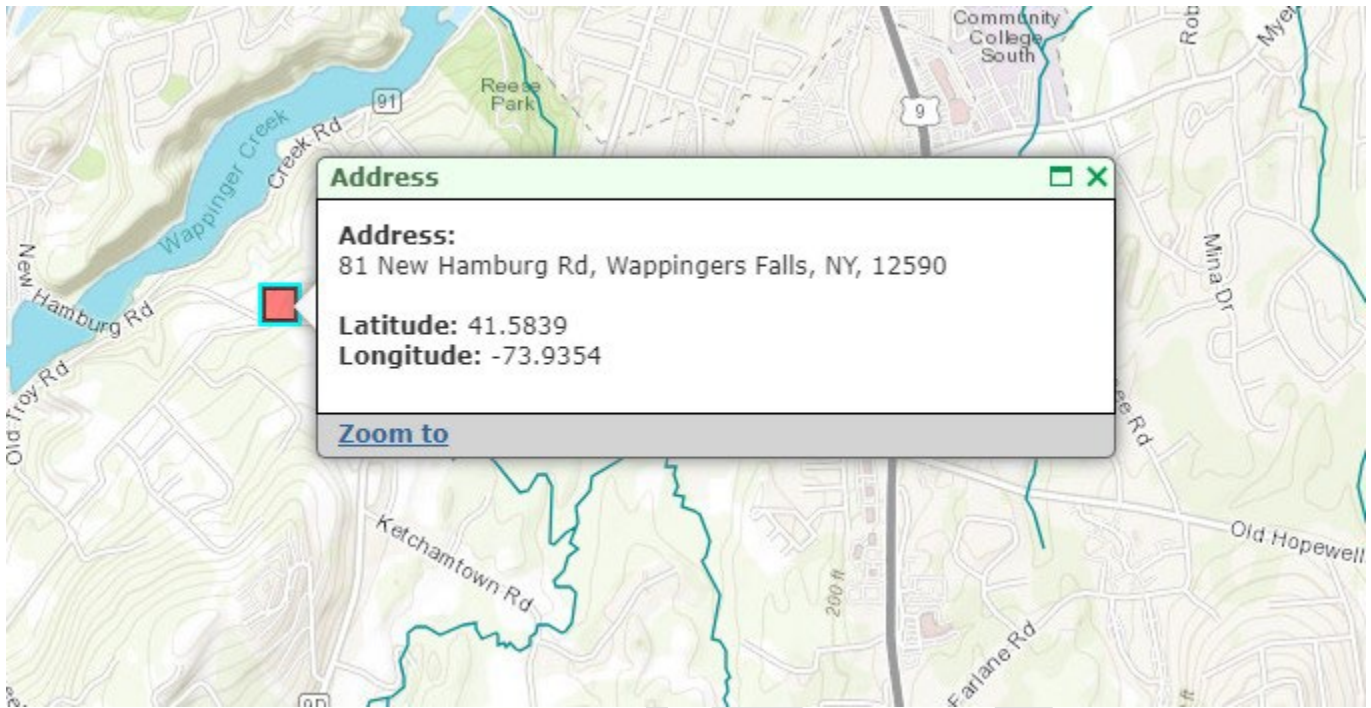

DRAFT

GENERAL REQUIREMENTS

- A. The regulations in 6 NYCRR Part 750 are hereby incorporated by reference and the conditions are enforceable requirements under this permit. The permittee shall comply with all requirements set forth in this permit and with all the applicable requirements of 6 NYCRR Part 750 incorporated into this permit by reference, including but not limited to the regulations in paragraphs B through H as follows:
- B. General Conditions
- | | |
|--------------------------------------------------|-----------------------------------------|
| 1. Duty to comply | 6 NYCRR 750-2.1(e) & 2.4 |
| 2. Duty to reapply | 6 NYCRR 750-1.16(a) |
| 3. Need to halt or reduce activity not a defense | 6 NYCRR 750-2.1(g) |
| 4. Duty to mitigate | 6 NYCRR 750-2.7(f) |
| 5. Permit actions | 6 NYCRR 750-1.1(c), 1.18, 1.20 & 2.1(h) |
| 6. Property rights | 6 NYCRR 750-2.2(b) |
| 7. Duty to provide information | 6 NYCRR 750-2.1(i) |
| 8. Inspection and entry | 6 NYCRR 750-2.1(a) & 2.3 |
- C. Operation and Maintenance
- | | |
|-----------------------------------|--------------------------------------|
| 1. Proper Operation & Maintenance | 6 NYCRR 750-2.8 |
| 2. Bypass | 6 NYCRR 750-1.2(a)(17), 2.8(b) & 2.7 |
| 3. Upset | 6 NYCRR 750-1.2(a)(94) & 2.8(c) |
- D. Monitoring and Records
- | | |
|---------------------------|------------------------------------------------------------------|
| 1. Monitoring and records | 6 NYCRR 750-2.5(a)(2), 2.5(a)(6), 2.5(c)(1), 2.5(c)(2), & 2.5(d) |
| 2. Signatory requirements | 6 NYCRR 750-1.8 & 2.5(b) |
- E. Reporting Requirements
- | | |
|-----------------------------------------|-----------------------------------|
| 1. Reporting requirements for non-POTWs | 6 NYCRR 750-2.5, 2.6, 2.7, & 1.17 |
| 2. Anticipated noncompliance | 6 NYCRR 750-2.7(a) |
| 3. Transfers | 6 NYCRR 750-1.17 |
| 4. Monitoring reports | 6 NYCRR 750-2.5(e) |
| 5. Compliance schedules | 6 NYCRR 750-1.14(d) |
| 6. 24-hour reporting | 6 NYCRR 750-2.7(c) & (d) |
| 7. Other noncompliance | 6 NYCRR 750-2.7(e) |
| 8. Other information | 6 NYCRR 750-2.1(f) |
- F. Sludge Management
The permittee shall comply with all applicable requirements of 6 NYCRR Part 360.
- G. SPDES Permit Program Fee
The permittee shall pay to the Department an annual SPDES permit program fee within 30 days of the date of the first invoice, unless otherwise directed by the Department, and shall comply with all applicable requirements of ECL 72-0602 and 6 NYCRR Parts 480, 481 and 485. Note that if there is inconsistency between the fees specified in ECL 72-0602 and 6 NYCRR Part 485, the ECL 72-0602 fees govern.
- H. Water Treatment Chemicals (WTCs)
New or increased use and discharge of a WTC requires prior Department review and authorization. At a minimum, the permittee must notify the Department in writing of its intent to change WTC use by submitting a completed *WTC Notification Form* for each proposed WTC. The Department will review that submittal and determine if a SPDES permit modification is necessary or whether WTC review and authorization may proceed outside of the formal permit administrative process. The majority of WTC authorizations do not require SPDES permit modification. In any event, use and discharge of a WTC shall not proceed without prior authorization from the Department. Examples of WTCs include biocides, coagulants, conditioners, corrosion inhibitors, defoamers, deposit control agents, flocculants, scale inhibitors, sequestrants, and settling aids.
1. WTC use shall not exceed the rate explicitly authorized by this permit or otherwise authorized by the Department.
 2. The permittee shall maintain a logbook of all WTC use, noting for each WTC the date, time, exact location, and amount of each dosage, and, the name of the individual applying or measuring the chemical. The logbook must also document that adequate process controls are in place to ensure excessive levels of WTCs are not used.
 3. The permittee shall submit a completed WTC Annual Report Form each year that they use and discharge WTCs. This form shall be submitted in electronic format and attached to either the December DMR or the annual monitoring report required below. The *WTC Notification Form and WTC Annual Report Form* are available from the Department's website at: <http://www.dec.ny.gov/permits/93245.html>

RECORDING, REPORTING AND ADDITIONAL MONITORING REQUIREMENTS

- A. The monitoring information required by this permit shall be retained for a period of at least five years from the date of the sampling for subsequent inspection by the Department or its designated agent.
- B. Annual SPDES Monitoring Reports: An annual report shall be submitted to the Department by February 1st each year. The report shall summarize information for January to December of the previous year and shall be submitted electronically, or in hardcopy format, utilizing the SPDES Annual Report Form available on the Department's website.

Hard copy submission of the Annual Report shall be submitted to the Regional Water Engineer at the address below:

Department of Environmental Conservation
Regional Water Engineer, Region 3
21 South Putt Corners Road
New Paltz, New York, 12561

Phone: (845) 256 - 3000
Email: dow.r3@dec.ny.gov

- C. Monitoring and analysis shall be conducted using sufficiently sensitive test procedures approved under 40 CFR Part 136, unless other test procedures have been specified in this permit.
- D. More frequent monitoring of the discharge(s), monitoring point(s), or waters of the State than required by the permit, where analysis is performed by a certified laboratory or where such analysis is not required to be performed by a certified laboratory, shall be included in the calculations and recording of the data on the corresponding DMRs or the annual monitoring reports.
- E. Calculations which require averaging of measurements shall utilize an arithmetic mean unless otherwise specified in this permit.
- F. Unless otherwise specified, all information recorded on the DMRs or the annual monitoring reports shall be based upon measurements and sampling carried out during the most recently completed reporting period.
- G. Any laboratory test or sample analysis required by this permit for which the State Commissioner of Health issues certificates of approval pursuant to section 502 of the Public Health Law shall be conducted by a laboratory which has been issued a certificate of approval. Inquiries regarding laboratory certification should be directed to the New York State Department of Health, Environmental Laboratory Accreditation Program.

SPDES Permit Fact Sheet

Obercreek PL

Obercreek Brewery & Tasting Room NY



Summary of Permit Changes

A new State Pollutant Discharge Elimination System (SPDES) permit has been finalized for the Obercreek Brewery & Tasting Room.

This fact sheet summarizes the information used to determine the effluent limitations (limits) and other conditions contained in the permit. General background information including the regulatory basis for the effluent limitations and other conditions are in the [Appendix](#) linked throughout this fact sheet.

Administrative History

6/4/2024 The Obercreek PL submitted a NY-2C permit application.

Date DEC published a notice of complete application in the Environmental Notice Bulletin (ENB).

Date The **Permittee** provided notice in the **Name of Newspaper**. The publications contain information on the public notice process. The public comment period commenced on **Date**.

The Notice of Complete Application, published in the [Environmental Notice Bulletin](#) and newspapers, contains information on the public notice process.

Facility Information

This is an industrial facility (SIC code(s)2082) that produces 4,796 GPD Effluent consists of wastewater. Effluent consists of treated sanitary waste and brewery process wastewater. The proposed treatment system includes the following treatment units:

- Primary Treatment: Septic tanks
- Secondary Treatment: Absorption beds
- Subsurface discharge

Site Overview

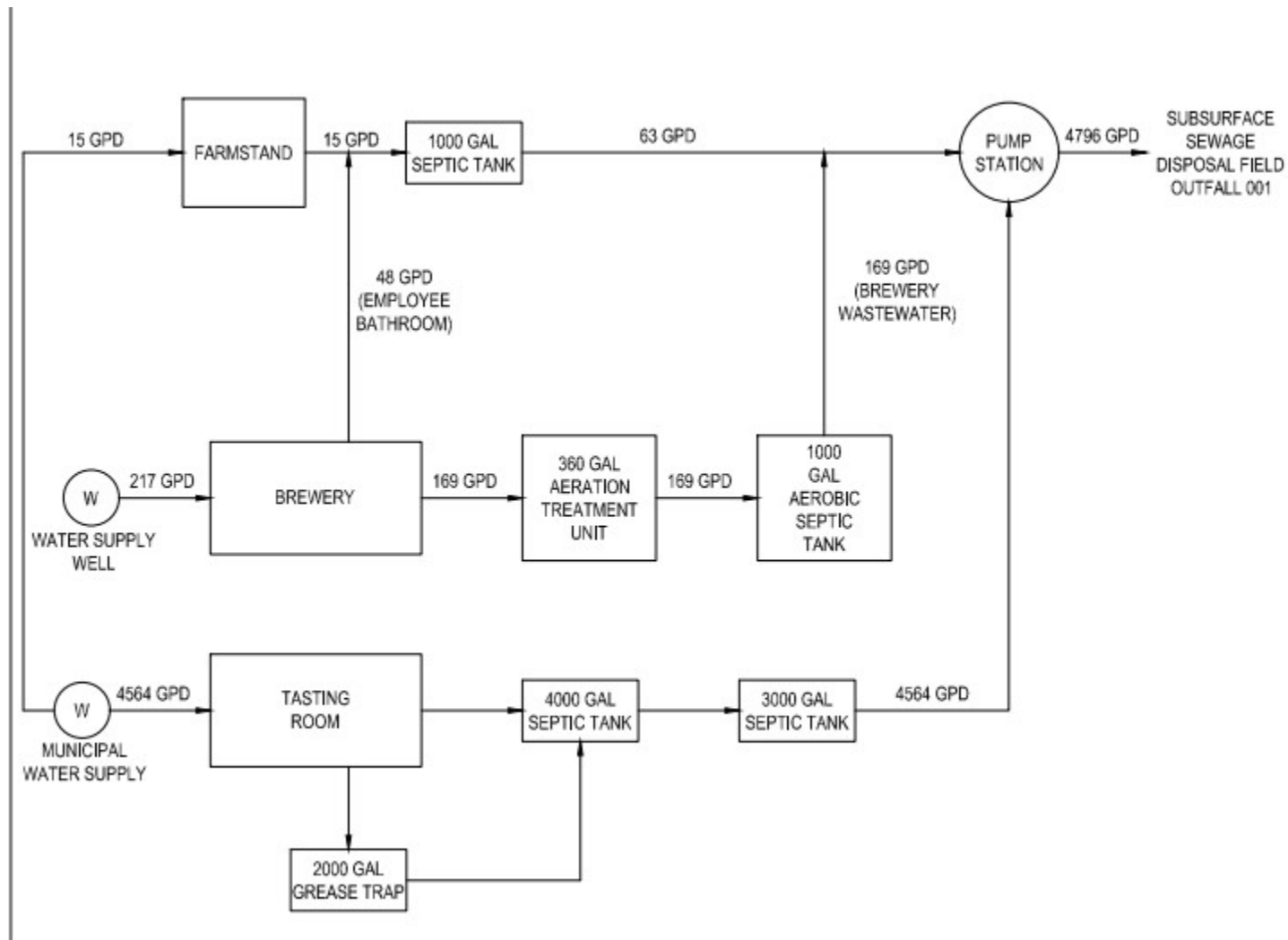

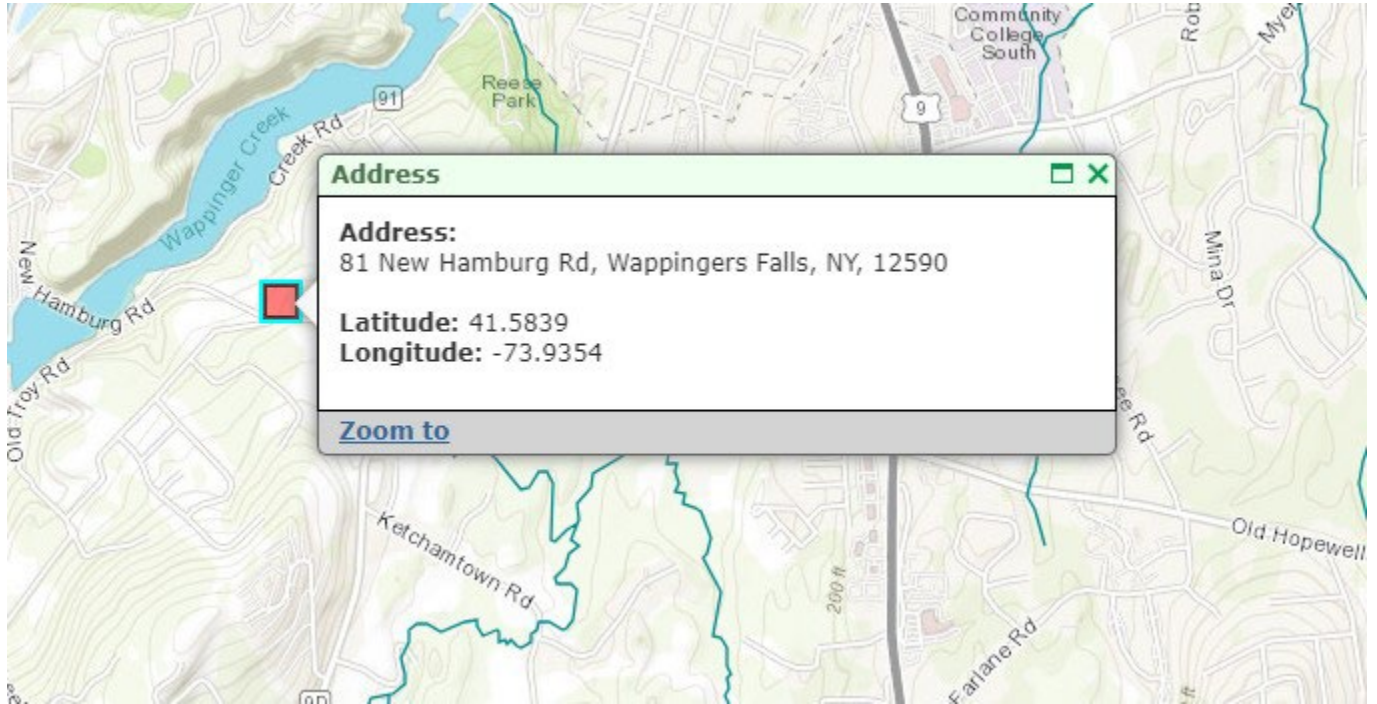

Receiving Water Information

The facility proposes to discharge via the following outfalls:

Outfall No.	SIC Code	Wastewater Type	Receiving Water
001	2082	Treated sanitary waste and brewery process water	Groundwater, Class GA

Permit Requirements

The technology based effluent limitations ([TBELs](#)), water quality-based effluent limitations ([WQBELs](#)), [Existing Effluent Quality](#) and a discussion of the selected effluent limitation for each pollutant present in the discharge.

[Appendix Link](#)

Antidegradation

The permit contains effluent limitations which ensure that the best usages of the receiving waters will be maintained. The Notice of Complete Application published in the Environmental Notice Bulletin contains information on the State Environmental Quality Review (SEQR)¹ determination.

[Appendix Link](#)

¹ As prescribed by 6 NYCRR Part 617

Appendix: Regulatory and Technical Basis of Permit Authorizations

The Appendix is meant to supplement the fact sheet for multiple types of SPDES permits. Portions of this Appendix may not be applicable to this specific permit.

Regulatory References

The provisions of the permit are based largely upon 40 CFR 122 subpart C and 6 NYCRR Part 750 and include monitoring, recording, reporting, and compliance requirements, as well as general conditions applicable to all SPDES permits. Below are the most common citations for the requirements included in SPDES permits:

- Clean Water Act (CWA) 33 section USC 1251 to 1387
- Environmental Conservation Law (ECL) Articles 17 and 70
- Federal Regulations
 - 40 CFR, Chapter I, subchapters D, N, and O
- State environmental regulations
 - 6 NYCRR Part 621
 - 6 NYCRR Part 750
 - 6 NYCRR Parts 700 - 704 – Best use and other requirements applicable to water classes
 - 6 NYCRR Parts 800 – 941 - Classification of individual surface waters
- NYSDEC water program policy, referred to as Technical and Operational Guidance Series (TOGS)
- USEPA Office of Water Technical Support Document for Water Quality-based Toxics Control, March 1991, Appendix E

The following is a quick guide to the references used within the fact sheet:

SPDES Permit Requirements	Regulatory Reference
Anti-backsliding	6 NYCRR 750-1.10(c)
Best Management Practices (BMPS) for CSOs	6 NYCRR 750-2.8(a)(2)
Environmental Benefits Permit Strategy (EBPS)	6 NYCRR 750-1.18, NYS ECL 17-0817(4), TOGS 1.2.2 (revised January 25,2012)
Exceptions for Type I SSO Outfalls (bypass)	6 NYCRR 750-2.8(b)(2), 40 CFR 122.41
Mercury Multiple Discharge Variance	Division of Water Program Policy 1.3.10 (DOW 1.3.10)
Mixing Zone and Critical Water Information	TOGS 1.3.1 & Amendments
PCB Minimization Program	40 CFR Part 132 Appendix F Procedure 8, 6 NYCRR 750-1.13(a) and 750-1.14(f), and TOGS 1.2.1
Pollutant Minimization Program (PMP)	6 NYCRR 750-1.13(a), 750-1.14(f), TOGS 1.2.1
Schedules of Compliance	6 NYCRR 750-1.14
Sewage Pollution Right to Know (SPRTK)	NYS ECL 17-0826-a, 6 NYCRR 750-2.7
State Administrative Procedure Act (SAPA)	State Administrative Procedure Act Section 401(2), 6 NYCRR 621.11(l)
State Environmental Quality Review (SEQR)	6 NYCRR Part 617
USEPA Effluent Limitation Guidelines (ELGs)	40 CFR Parts 405-471
USEPA National CSO Policy	33 USC Section 1342(q)
Whole Effluent Toxicity (WET) Testing	TOGS 1.3.2
General Provisions of a SPDES Permit Department Request for Additional Information	NYCRR 750-2.1(i)

Outfall and Receiving Water Information

Existing Effluent Quality

The existing effluent quality is determined from a statistical evaluation of effluent data in accordance with TOGS 1.2.1 and the USEPA Office of Water, Technical Support Document for Water Quality-based Toxics Control, March 1991, Appendix E (TSD). The existing effluent quality is equal to the 95th (monthly average) and 99th (daily maximum) percentiles of the lognormal distribution of existing effluent data. When there are greater than three non-detects, a delta-lognormal distribution is assumed, and delta-lognormal calculations are used to determine the monthly average and daily maximum pollutant concentrations. Statistical calculations are not performed for parameters where there are less than ten data points. If additional data is needed, a monitoring requirement may

be specified either through routine monitoring or a short-term high intensity monitoring program. The [Pollutant Summary Table](#) identifies the number of sample data points available.

Permit Requirements

Basis for Effluent Limitations

Sections 101, 301, 304, 308, 401, 402, and 405 of the CWA and Titles 5, 7, and 8 of Article 17 ECL, as well as their implementing federal and state regulations, and related guidance, provide the basis for the effluent limitations and other conditions in the permit.

When conducting a full technical review of an existing permit, the previous effluent limitations form the basis for the next permit. Existing effluent quality is evaluated against the existing effluent limitations to determine if these should be continued, revised, or deleted. Generally, existing limitations are continued unless there are changed conditions at the facility, the facility demonstrates an ability to meet more stringent limitations, or in response to updated regulatory requirements. Pollutant monitoring data is also reviewed to determine the presence of additional contaminants that should be included in the permit based on a reasonable potential analysis to cause or contribute to a water quality standards violation.

Antidegradation Policy

New York State implements the antidegradation portion of the CWA based upon two documents: (1) Organization and Delegation Memorandum #85-40, "Water Quality Antidegradation Policy" (September 9, 1985); and, (2) TOGS 1.3.9, "Implementation of the NYSDEC Antidegradation Policy – Great Lakes Basin (Supplement to Antidegradation Policy dated September 9, 1985) (undated)." The permit for the facility contains effluent limitations which ensure that the existing best usage of the receiving waters will be maintained. To further support the antidegradation policy, SPDES applications have been reviewed in accordance with the State Environmental Quality Review Act (SEQR) as prescribed by 6 NYCRR Part 617.

Effluent Limitations

In developing a permit, the Department determines the technology-based effluent limitations (TBELs) and then evaluates the water quality expected to result from technology controls to determine if any exceedances of water quality criteria in the receiving water might result. If there is a reasonable potential for exceedances of water quality criteria to occur, water quality-based effluent limitations (WQBELs) are developed. A WQBEL is designed to ensure that the water quality standards of receiving waters are met. In general, the CWA requires that the effluent limitations for a particular pollutant are the more stringent of either the TBEL or WQBEL.

Technology-based Effluent Limitations (TBELs) for Industrial Facilities to Groundwater

TBELS aim to prevent pollution by requiring a minimum level of effluent quality that is attainable using demonstrated technologies for reducing discharges of pollutants or pollution into the waters of the United States. Requirements for discharges from industrial facilities to groundwater are summarized in TOGS 1.2.1. In accordance with TOGS 1.2.1, for facilities discharging to groundwater:

- Discharges will typically be limited to the more stringent of the groundwater effluent standards in 6 NYCRR 703.6 or the applicable treatment technology listed in TOGS 1.2.1 Attachment (C).
- Discharges from industrial facilities which contain nitrogen or nitrogen compounds include effluent limitations for Nitrate of 20 mg/L (as N). Groundwater discharges in Nassau and Suffolk Counties are required to achieve an effluent standard for Total Nitrogen of 10 mg/L (as N).
- Disinfection will typically not be required for discharges to groundwater unless local public health concerns exist due to exposure or contact with effluent.

Water Quality-Based Effluent Limitations (WQBELs) for Discharges to Groundwater

The procedure for developing WQBELs includes identifying the pollutants present in the discharge(s), identifying water quality criteria applicable to these pollutants, determining if WQBELs are necessary (reasonable potential), and calculating the WQBELs. For groundwater discharges, if the expected concentration of the pollutant of concern in the receiving water may exceed the ambient groundwater

quality standard or guidance value, then there is reasonable potential that the discharge may cause or contribute to a violation of the water quality, and a WQBEL for the pollutant is required.

WQBELs for groundwater discharges are based on the groundwater effluent limits set forth in 6 NYCRR Part 703 (Surface Water and Groundwater Quality Standards and Groundwater Effluent Limitations) except as noted in 6 NYCRR 702.21. TOGS 1.1.1 provides a listing of groundwater effluent limitations for substances having an ambient water quality standard or guidance value. Groundwater effluent limitations are applied at the point of discharge to the groundwater distribution system.

For land treatment systems with no accessible final sampling points, such as constructed wetland treatment systems or buried sand filters, permit limitations for groundwater discharges are typically based on ambient groundwater quality standards or guidance values applied at representative down gradient monitoring well(s). Limitations at the downgradient sampling point are set at the Class GA ambient groundwater standards, rather than at the groundwater effluent limits promulgated under 6 NYCRR 703.6, as compliance is determined based upon the concentrations present in the downgradient groundwater monitoring well at the groundwater interface.

Class GA standards are established for the protection of sources of drinking water designated as Health (Water Source) or H(W)S in TOGS 1.1.1. As such, effluent limitations based on aquatic life criteria and WET testing requirements are not applicable to groundwater discharges.

Minimum Level of Detection

Pursuant to 40 CFR 122.44(i)(1)(iv) and 6 NYCRR 750-2.5(d), SPDES permits must contain monitoring requirements using sufficiently sensitive test procedures approved under 40 CFR Part 136. A method is “sufficiently sensitive” when the method’s minimum level (ML) is at or below the level of the effluent limitation established in the permit for the measured pollutant parameter; or the lowest ML of the analytical methods approved under 40 CFR Part 136. The ML represents the lowest level that can be measured within specified limitations of precision and accuracy during routine laboratory operations on most effluent matrices. When establishing effluent limitations for a specific parameter (based on technology or water quality requirements), it is possible that the calculated limitation will fall below the ML established by the approved analytical method(s). In these instances, the calculated limitation is included in the permit with a compliance level set equal to the ML of the most sensitive method.

Monitoring Requirements

CWA section 308, 40 CFR 122.44(i), 6 NYCRR 750-1.13, and 750-2.5 require that monitoring be included in permits to determine compliance with effluent limitations. Additional effluent monitoring may also be required to gather data to determine if effluent limitations may be required. The permittee is responsible for conducting the monitoring and reporting results on Discharge Monitoring Reports (DMRs). The permit contains the monitoring requirements for the facility. Monitoring frequency is based on the minimum sampling necessary to adequately monitor the facility’s performance and characterize the nature of the discharge of the monitored flow or pollutant. Variable effluent flows and pollutant levels may be required to be monitored at more frequent intervals than relatively constant effluent flow and pollutant levels (6 NYCRR 750-1.13). For industrial facilities, sampling frequency is based on guidance provided in TOGS 1.2.1. For municipal facilities, sampling frequency is based on guidance provided in TOGS 1.3.3.

For groundwater discharges, monitoring of downstream wells may be included to demonstrate compliance with ambient groundwater quality standards. Additional effluent monitoring may also be required to gather data to determine if effluent limitations may be required.